

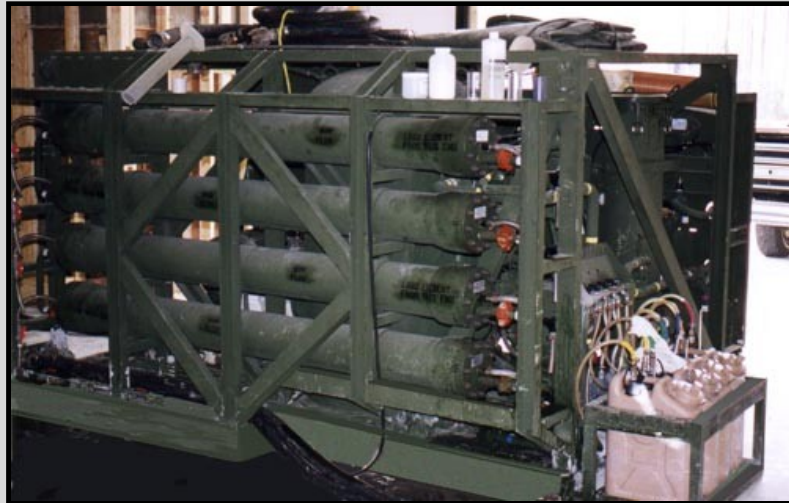

**AIR FORCE HANDBOOK 10-222, Volume 9
1 May 1999**

**GUIDE TO REVERSE OSMOSIS WATER
PURIFICATION UNIT INSTALLATION AND
OPERATION**



DEPARTMENT OF THE AIR FORCE



Operations

**GUIDE TO REVERSE OSMOSIS WATER
PURIFICATION UNIT INSTALLATION AND
OPERATION**

OPR: HQ AFCESA/CEXR (Major Gregory A. Cummings)
Certified by: HQ AFCESA/CEX (Colonel Bruce F. Mc Connell)
Pages 98/Distribution: F

This handbook is designed to assist you in setting up and operating the reverse osmosis water purification unit (ROWPU). It discusses site selection and layout; major components associated with the unit; set up, operation and shutdown procedures and the more critical maintenance activities needed to keep the unit functional. When coupled with information contained in Technical Order 40W4-13-41, AFPAM 10-219, Vol. 5, Bare Base Conceptual Planning Guide; AFH 10-222, Volume 1, Guide to Bare Base Development; and instruction received at Silver Flag and 49th MMG training sites, personnel should be capable of effectively setting up a basic water plant and producing potable water under contingency conditions. Information in this handbook assumes the reader has a basic familiarity with the ROWPU. Refer to the unit's technical orders for a detailed description, parts breakdown, troubleshooting information, and current changes. Remember, there are different models of the ROWPU in use – be sure the technical order you are using matches the equipment. Also available for review is a computer-based Qualification Training Package (QTP) on the unit.

	Page
INTRODUCTION	5
CHARACTERISTICS/MAJOR COMPONENTS.....	11
PRINCIPLES OF OPERATION	24
ROWPU SET UP	26
OPERATION	48
KEY MAINTENANCE ACTIVITIES.....	58

SHUTDOWN PROCEDURES.....	77
RADIOLOGICAL/CHEMICAL OPERATIONS	79
RECONSTITUTION	86

Figures

1. Reverse Osmosis Water Purification Unit.....	5
2. Reverse Osmosis Pressure Tubes.....	12
3. Junction Box.....	13
4. Control Panel.....	14
5. Water Meter	14
6. Cartridge Filter	15
7. Reverse Osmosis Pump Assembly.....	15
8. Multimedia Filter.....	16
9. Chemical Feed Pump.....	17
10. Distribution Pump.....	18
11. 3,000-Gallon Onion Tank	18
12. Backwash Pump	19
13. Raw Water Pump.....	19
14. Strainer and Float.....	20
15. Suction and Discharge Hoses	21
16. Deionization Cartridges	21
17. R.O. Elements and Cartridge Filters	22
18. Total Dissolved Solids Monitor.....	23
19. Chemical Cans.....	23
20. Schematic Diagram of the ROWPU Process.....	25
21. Quick Disconnect Fittings on Control Panel	29
22. Fittings Attached to Raw Water Pump #1.....	29
23. Backwash Pump Assembly	31
24. Typical ROWPU Equipment Layout	32
25. Raw Water System Layout.....	33
26. Electrical Connections from Raw Water Pumps to ROWPU	34
27. Backwash System Layout	35
28. Product Water System Layout	37
29. Waste Water System Connections.....	38

30	Chemical Feed Can Connections.....	41
31	Electrical Power Connections at Junction Box.....	43
32	Drain Valves.....	44
33	VENT VESSELS Gate Valve.....	45
34	VENT PRODUCT WATER Valve.....	45
35	Front R.O. Pressure Tube Vent/Sample Valves.....	46
36	Rear R.O. Pressure Tube Vent/Sample Valves.....	47
37	Chemical Feed Run/Prime Values in PRIME Position	47
38	Chemical Feed Pump Controls	49
39	Vent Pipe for the Three Vent Valves	52
40	Solid State Backwash Timer	58
41	R.O. Element Cleaning Switch.....	59
42	Cartridge Filter Drains #1 and #2	68
43	Cartridge Filter Cover Removal	69
44	Cartridge Filter Tube Replacement	69
45	Eyebolt Tightening Sequence.....	70
46	R.O. Pressure Tube Water Flow	71
47	End Cap Details.....	72
48	Puller Rod Components	73
49	Puller Rod Inserted into R.O. Element String	73
50	R.O. Element String Details	74
51.	Insertion of R.O. Element into Pressure Tube	75
52	Raw Water System Layout for Radiological/Chemical Operations.....	80
53	Deionization Cartridge Assembly.....	81
54	Product Water System for Radiological/Chemical Operations.....	83
55	Stowage Plan, Bottom Layer	94
56	Stowage Plan, Middle Layer	95
57	Stowage Plan, Top Layer	96
58	Hard Rubber Hose Stowage	97

Tables

1.	Water Production Package Components	6
2	Initial Water Distribution Package Components.....	8
3	Standard Package Components.....	8

4	Source Run Additive Components.....	9
5	High Threat Additive Components.....	9
6	ROWPU Piping Color-Coding	11
7	Accessory Packing Layers.....	28
8	Normal and Problem-Point Gauge Indications.....	55

INTRODUCTION

GUIDE TO REVERSE OSMOSIS WATER PURIFICATION UNIT INSTALLATION AND OPERATION

PURPOSE OF BOOKLET

The ROWPU is the heart of the Harvest Falcon water production and distribution system. While during contingencies we attempt to use locally available potable water if possible, in many scenarios ROWPU (figure 1) use may be the only answer. This handbook provides an outline and checklist refresher for utilities personnel tasked to set up and operate the bare base water production system at an austere location.

Figure 1. Reverse Osmosis Water Purification Unit.



Two basic planning factors are used to estimate water requirements for contingency operations. If the deployed force is assigned to a location that has an established water production and supply capability, such as a host nation plant and distribution system, 50 gallons per day per person is allocated. At a location where only mobile assets (e.g. Harvest Falcon system) are used the planning factor is reduced to 20 gallons per person per day. Assets provided in the Falcon package are sized to this lower planning factor. The planning factor for water storage is a 5-day supply.

Harvest Falcon water system assets are included in the first two sets of the overall Harvest Falcon deployment package. The standard Housekeeping Set contains ROWPUs and soft wall hose for establishing an initial water production and distribution network. The Industrial Operations Set includes hard wall piping and pumps to provide a more permanent, long term distribution system. Harvest Falcon water system components are being repackaged at this point in time to lessen airlift requirements; the end result, however, does not significantly alter water production capabilities at a bare base location. The new packages are as follows:

Water Production Package—This package, deployed as an increment of the Housekeeping Set, provides ROWPUs, onion tanks and storage bladders for support of up to 1,100 personnel. A minimal amount of distribution line is included in this package; therefore, the ROWPUs will have to be set up near the source or have raw water trucked in to them. The ROWPUs will just meet the daily demands of the 1,100-person population; there is little spare production capacity. Table 1 shows the major components of this package.

Table 1. Water Production Package Components.

EQUIPMENT	SIZE	QUANTITY
ROWPU	600 gph	2
Onion Tank	3,000 gal	4
Bladder, Potable Water	20,000 gal	2
Bladder, Raw Water	20,000 gal	1

Initial Water Distribution Package—Included as an increment of the first Housekeeping Set sent to an installation, the initial water distribution package contains pumps, soft wall hose and bladders. It is sized to support 1,100 personnel. Table 2 illustrates the primary components of the package.

Standard Package—This package contains an additional ROWPU, storage bladders and hard wall piping. It is shipped as part of the Industrial Operations Set. The additional ROWPU permits maintenance to be performed on other units without sacrificing water production quantities. The piping allows installation of a pressurized hard wall distribution system. Major components are shown in table 3.

Source Run Additive Package—The source run additive package allows base water production facilities to be positioned up to two miles from the raw water source. If required at an installation, it will be shipped as part of the Industrial Operations Set or requested as a separate unit type code. Components are listed in table 4.

High Threat Additive Package—If an installation is located in what would be considered a high threat area, the high threat additive package would be provided to permit establishment of a dispersed facility configuration. Basically, the capability of setting up two water production plants and a second hard wall distribution loop is provided. This allows dispersal of production assets and much greater separation between all base facilities. If the package is considered necessary for a location, it is shipped as part of the Industrial Operations Set. Components are shown in table 5.

Table 2. Initial Water Distribution Package Components.

EQUIPMENT	SIZE	QUANTITY
Bladder, Potable Water	10,000 gal	2
Bladder, Raw Water	20,000 gal	1
Raw Water Pump	250 gpm	2
Potable Water Pump	130 gpm	2
Waste Water Pump	35 gpm	5
Hypochlorinator		1
Back Pressure Regulator		1
Raw Water Hose, Discharge	4"	5,440'
	2"	50'
Raw Water Hose, Suction	4"	120'
Pot. Water Hose, Discharge	4"	4,000'
	2"	2,350'
	1 1/2"	150'
Pot. Water Hose, Suction	4"	80'
Waste Water Hose	2"	1,400'

Table 3. Standard Package Components.

EQUIPMENT	SIZE	QUANTITY
ROWPU	600 gph	1
Onion Tank	3,000 gal	2
Bladder, Raw Water	20,000 gal	4
Bladder, Potable Water	20,000 gal	4
Raw Water Hose, Discharge	4"	1,000'
Potable Water Pipe	4"	9,215'
	2"	1,615'
	1 1/2"	4,940'
Waste Hose, Suction	2"	100'
Waste Hose, Discharge	2"	1,200'

Table 4. Source Run Additive Components.

EQUIPMENT	SIZE	QUANTITY
Raw Water Pump	250 gpm	1
Raw Water Pipe	6"	10,640'
Raw Water Hose, Discharge	4"	5,280'
Raw Water Hose, Suction	6"	80'

Table 5. High Threat Additive Components.

EQUIPMENT	SIZE	QUANTITY
Lift Station	180 gpm	1
Potable Water Pump	130 gpm	2
Hypochlorinator		1
Back Pressure Regulator		1
Waste Water Pipe	6"	380'
	4"	6,840'
	3"	2,850'
	2"	1,615'
Potable Water Pipe	4"	8,550'
	3"	5,510'
	2"	380'
	1 1/2"	1,710'
Pot. Water Hose, Suction	4"	40'

As you can see from the above package descriptions, you will receive two ROWPUs in every Housekeeping Set shipped in and one ROWPU in the Industrial Operations Set. Normally, only one Industrial Operations Set will be shipped to a location. Therefore, using an example of a 3,300-person deployment, you should receive seven ROWPUs. In a low threat area these seven units could be kept together in one location and serve as the base's entire water production capability. This would probably be the most

manpower-effective operation. In a high threat location, however, the units should be split as evenly as possible between at least two locations. Because of the criticality of the ROWPU units to base operations, we must accept some manpower inefficiencies for the sake of asset survivability.



CHARACTERISTICS/ MAJOR COMPONENTS

CHARACTERISTICS

The ROWPU is a mobile water purification unit that is used under field conditions to provide treated water for drinking, hygiene, sanitation, food preparation, and medical support purposes. Similar units are used by the Army and Navy. The ROWPU is capable of providing potable water at a rate of 600 gallons per hour. In a typical daily operation it is run for 20 hours and taken down for maintenance for four hours. The ROWPU is capable of processing saltwater, brackish water and freshwater. When fitted with deionization cartridges, the unit is also able to remove nuclear, biological and chemical contaminants from product water. Power for the ROWPU is normally provided from the Harvest Falcon electrical distribution system with a mobile 30 kW mission essential power generator installed as an emergency backup. Weighing approximately 7,800 pounds, the unit requires a forklift for movement and placement. It is 9 ½ feet long, 7 feet wide and 5 ¾ feet high. Several accessory components (pumps, hose, tanks, etc.) are needed to support the ROWPU operation and are packed in layers in the ROWPU container itself. To assist in operations and maintenance activities on the unit, piping on the ROWPU is color-coded. Table 6 depicts the coding used.

Table 6. ROWPU Piping Color-Coding.

FUNCTION	COLOR
Raw Water	Black Band
Backwash Waste	Red Band
Filtered Water	Yellow Band
Product Water	Blue Band
Brine Discharge	Purple Band
Brine Piping on R.O. Pressure Vessels	Purple Band

MAJOR COMPONENTS

The major components associated with the ROWPU include unit components and accessory components. Unit components are those physically located on the ROWPU itself; accessory components are those that generally perform water plant distribution and storage functions.

Unit Components

Canvas Cover. The canvas cover protects the unit from the elements. It is rolled and strapped up during ROWPU operation.

Reverse Osmosis (R.O.) Pressure Tubes (figure 2). These tubes contain the R.O. elements through which water is forced at high pressures to remove dissolved solids.

Figure 2. Reverse Osmosis Pressure Tubes.



Junction Box (figure 3). Located adjacent to the control panel and above the R.O. pump assembly, the junction box contains circuit breakers, relays, etc. associated with the ROWPU electrical items. Also present are the electrical

receptacles for incoming power to the unit and outgoing power to various pumps.

Figure 3. Junction Box.



Control Panel (figure 4). The control panel contains the meters, valves and switches used to operate the unit. The panel also includes the coupling points used to connect hoses from various accessory components.

Water Meter (figure 5). Located behind the control panel, the water meter records the total number of gallons of product water produced by the unit.

Cartridge Filter (figure 6). Also located behind the control panel, the cartridge filter provides a second filtration of raw water prior to it being forced under pressure through the R.O. filter elements. The cartridge filter consists of eight filter tubes.

R.O. Pump Assembly (figure 7). The pump assembly consists of an electric motor and high pressure pump which are used to pump partially filtered water under high pressure through the R.O. filter elements.

Figure 4. Control Panel.



Figure 5. Water Meter.



Figure 6. Cartridge Filter.



Figure 7. Reverse Osmosis Pump Assembly.



Pulse Dampener. Located in the line between the R.O. pump assembly and the R.O. filter elements, the pulse dampener removes the surges in the water caused by the operation of the pump assembly.

Multimedia Filter (figure 8). The multimedia filter provides the first stage of filtration on incoming raw water. The filter is located behind the R.O. pressure tubes.

Figure 8. Multimedia Filter.



Chemical Feed Pump (figure 9). The chemical feed pump, located on the control panel end of the ROWPU, controls the amount of chemical treatment applied to the water as it is processed. Different ROWPU models have differing chemical feed pumps. Check the technical order for your machine for specific details. The operation of the feed pumps, however, is similar for all models.

Booster Pump. The booster pump forces water from the multimedia filter to the cartridge filter.

Figure 9. Chemical Feed Pump.



Accessory Components

Distribution Pump (figure 10). This electrically driven, 30 gpm pump draws product water from product water tanks and bladders and pumps it through the minimal distribution system that is part of the ROWPU package. This pump comes with the ROWPU and is not part of the Initial Water Distribution Package discussed earlier. It is meant to provide a basic capability to fill water buffaloes, igloo-type containers, etc.

Product Water Tanks (figure 11). Two 3,000-gallon onion tanks are provided for product water storage.

Backwash (Brine) Water Tank. A single 3,000-gallon onion tank is provided for brine water storage.

Backwash Pump (figure 12). This electrically driven, 120 gpm pump is used in the backwashing of the multimedia filter and cleaning of the R.O. elements.

Figure 10. Distribution Pump.



Figure 11. 3,000-Gallon Onion Tank.



Figure 12. Backwash Pump.



Raw Water Pumps (figure 13). Two of these electrically driven, 30 gpm pumps are used to draw raw water from the source and pump it to the ROWPU for processing.

Figure 13. Raw Water Pump.



Strainer and Float (figure 14). The strainer connects to the end of the raw water suction hose and keeps foreign objects from entering the raw water intake lines, pumps and ROWPU. The float is used to suspend the strainer in the raw water source.

Figure 14. Strainer and Float.



Suction Hoses (figure 15). Suction hoses are installed on the inlet side of most accessory pumps and are used to carry water to the pumps. They are hard walled, black in color, and have quick disconnect fittings. You will find both 1 ½" and 2" sizes in 10' lengths. A few sections are marked with a blue stripe—the stripe denotes the hose should be used for product water only.

Discharge Hoses (figure 15). Discharge hoses are installed on the outlet side of the accessory pumps to carry water, under pressure, away from the pumps. They are constructed of a soft rubber material, covered with white canvas and have quick disconnect fittings. Similar to the suction hose, the discharge hose comes in 1 ½" and 2" sizes in 25' lengths. Some of the sections also have a blue stripe denoting product water use only.

Figure 15. Suction and Discharge Hoses.



Deionization Cartridges (figure 16). Product water is pumped through these cartridges to remove NBC contaminants. Two cartridges are provided; one for radiological contaminants and one for chemical. Both must be used during operation in contaminated environments.

Figure 16. Deionization Cartridges.



Reverse Osmosis Elements (figure 17). Water is forced through these elements at high pressure to remove dissolved solids. Two elements are installed in each of the four reverse osmosis pressure tubes.

Cartridge Filter Tubes (figure 17). Eight of these filter tubes are placed in the cartridge filter (figure 6).

Figure 17. R.O. Elements and Cartridge Filters.



Total Dissolved Solids Monitor (figure 18). This monitoring device is mounted on the control panel prior to ROWPU operation and measures the level of total dissolved solids in water being produced.

Chemical Cans (figure 19). Four chemical cans hold the chemicals necessary to treat the raw water being processed. They are connected to the chemical feed pump by transparent flexible hoses.

Also included as accessory components are numerous valves, couplings, adapters, reducers and nipples used to set up the ROWPU water storage and piping network.

Figure 18. Total Dissolved Solids Monitor.



Figure 19. Chemical Cans.



PRINCIPLES OF OPERATION

The ROWPU removes suspended solids (turbidity), chemicals, and solids held in solution (dissolved solids) found in most fresh water and seawater sources to a level fit for human consumption. Raw water is pumped from the source to the ROWPU where it is injected with a polymer which starts coagulating suspended solids. Sodium hex is then injected into the water stream to reduce the degree of scaling and corrosion within the ROWPU components and piping caused by processing of hard water. The raw water then passes through the multimedia filter for removal of suspended solids. After leaving the multimedia filter, the raw water is injected with citric acid to maintain pH levels and help reduce scale deposits that build up on the reverse osmosis elements. The water then is passed through the cartridge filter to remove the fine suspended solids that passed through the multimedia filter. Next the R.O. pump increases the pressure of the raw water stream and sends it through the pulse dampener in preparation for entering the R.O. pressure tubes and filter elements. This high pressure forces the water through the semipermeable membranes of the filter elements which separate the water stream into a product (fresh) water stream and a brine concentrate stream. The filter elements essentially remove any remaining suspended solids and dissolved solids. Typically, for every gallon of product water produced, two gallons of brine concentrate are created. The product water is treated with chlorine to reduce bacteria and sent on to the base's fresh water storage and distribution network. Some of the brine water is retained for backwashing filters and R.O. elements but the majority of the brine water is sent to waste. Often brine is returned to the water source downstream from the strainer and float or an evaporation lagoon is built. Figure 20 is a schematic of the ROWPU operation.

Figure 20. Schematic Diagram of the ROWPU Process.

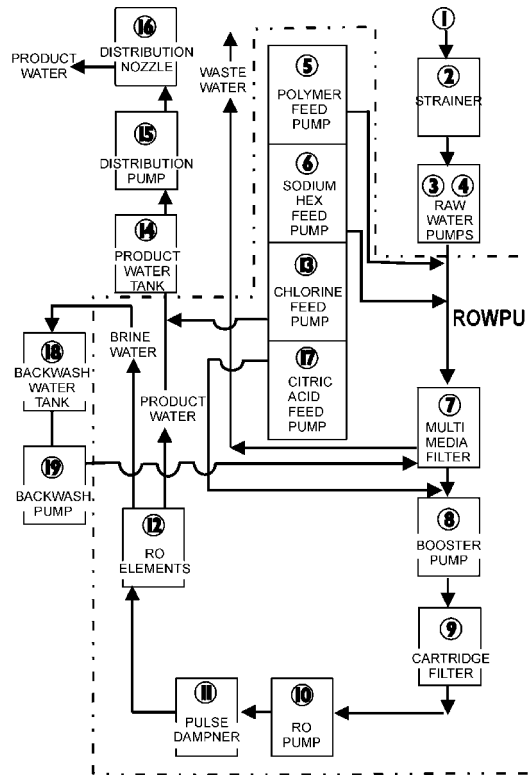

ROWPU SET UP**Site Selection**

Several conditions bear on the site selection process for ROWPU operations. Essentially you are setting up the water plant(s) for your installation and once in place they become difficult to relocate due to the general permanency of the water distribution system after it has been installed. Major factors you will need to consider are the end population of your base, its threat condition, and its topographic features.

Strive to obtain information on the anticipated final base population as early as possible. Base population drives the number of ROWPUs you will receive. With this data you can better plan your plant layouts and appropriate location(s). Your wing logistics plans or operations plans people should be able to help out on population figures.

The threat condition for your base will determine whether you will set up for dispersed operations or not. Check with wing Intelligence people and the Office of Special Investigations (OSI) staff for threat information.

With the asset quantities and dispersal mode questions answered you now have to consider the geographic and terrain features of your base. If you are fortunate enough to have a good on-base source, you can start your ROWPU operation adjacent to it. If not, you will have to haul water from a more distant source to your plant. Although not prohibited, think twice before locating water production assets off base where they become more vulnerable.

When laying out your plant area, be sure to leave sufficient space to accommodate the several storage bladders that come with the water distribution system. You will have bladders on both the raw water and product water sides of the ROWPUs. Figure on 40% of your storage bladders being dedicated to raw water storage, the remaining 60% to product water

storage. If a dispersed operation is called for, the rule of thumb is to split the bladder assets equally between plants—they will be tied together eventually with distribution lines anyway. Be sure to leave enough space between plant assets (ROWPUs, onion tanks, bladders) for vehicle access. You may have to haul parts, chemicals, or even water in and out. Also look critically at the immediate area where you will be setting up your equipment—since you will be near the water source watch that you don't choose a location that is prone to flooding or abnormal tidal action.

Disposing of brine discharge from the ROWPUs can be a major undertaking. Ideally, you should attempt to feed the brine back into the source downstream from the intake line. Often this is not possible. Your option becomes construction of a sizable evaporation pond or cutting of a channel to an unoccupied lowland area.

Assembly and Preparation

Assembly and preparation of the ROWPU system will be discussed in the most basic state, i.e., one unit plus accessory components. Although you will have more than one unit to set up and operate, all units are similar both in function and installation. Steps to take for assembly and preparation are as follows (check the technical order for your unit, some units may have slight packaging differences):

Place the unit on level ground, roll up and secure its canvas cover and remove the cross braces on the end of the unit protecting the stacked accessories.

Loosen and disconnect the three cargo straps holding the accessories in place.

Remove hold down straps and unload all accessories. Accessories are packed in three layers and shown in table 7. Nine suction hoses are located on the side of the ROWPU frame near the R.O. pressure tubes.

Obtain the distribution pump, chemical feed cans and rack and calcium hypochlorite—these are shipped separate from the ROWPU.

Install 2-inch male quick disconnect fittings on WASTE, VENT VESSELS, and BACKWASH water hose couplings on the control panel (figure 21). Use Teflon tape on all pipe threads.

Install 1 ½-inch male quick disconnect fittings on PRODUCT WATER, BRINE, and RAW water hose couplings on the control panel (figure 21).

Assemble fittings on raw water pumps.

Install 1½-inch female quick disconnect fitting on suction coupling of raw water pump #1 (figure 22).

Table 7. Accessory Packing Layers.

Third Layer (top)	Two deionization cartridges
	Three 2-inch rubber hoses
	One 1 ½-inch hard rubber hose
Second Layer (middle)	Two storage chests
	Four canvas pump covers
	Three water tanks
First Layer (bottom)	Lug wrench
	R.O. element tool
	Paddle
	Sledge hammer
	Float
	Five utility pails
	Backwash pump
	Canvas hoses
	Two raw water pumps
	1 ½-inch suction hoses

Figure 21. Quick Disconnect Fittings on Control Panel.



Figure 22. Fittings Attached to Raw Water Pump #1.



Install 1 ½-inch male quick disconnect fitting on discharge coupling of raw water pump #1 (figure 22). Ensure drain and vent valve on pump are closed.

Install 1 ½-inch female quick disconnect fittings on suction and discharge couplings of raw water pump #2. Ensure drain and vent valve on pump are closed.

Install 1 ½-inch male quick disconnect fitting on raw water strainer.

Assemble fittings on backwash pump.

Remove tie straps securing strainer to backwash pump.

Connect strainer to discharge coupling on backwash pump (figure 23).

Bolt strainer to pump frame.

Install 2-inch female quick disconnect fitting on backwash strainer (figure 23).

Install 2-inch male quick disconnect fitting on suction coupling of backwash pump.

Close draincock on bottom of backwash pump.

Assemble fittings on distribution pump.

Install 1 ½-inch female quick disconnect fitting on suction coupling of distribution pump.

Install 1 ½-inch male quick disconnect fitting on discharge coupling of distribution pump.

Install 1 ½-inch female quick disconnect fitting on distribution nozzle.

Install one 2-inch female quick disconnect fitting on each end of the 2-inch gate valve.

Figure 23. Backwash Pump Assembly.



Install a 1 ½-inch female quick disconnect fitting on the 1 ½-inch gate valve.

Install a 1 ½-inch male quick disconnect fitting on the other end of the 1 ½-inch gate valve.

Install Total Dissolved Solids Monitor (figure 18) on ROWPU control panel.

Remove pin from control panel and position monitor under the two brackets. Replace pin back into control panel ensuring pin goes through hole in the base of the monitor.

Connect sensor cable from monitor to sensor receptacle on control panel.

Plug monitor power cable into power receptacle on control panel.

Position ROWPU and accessories in an operational configuration. See figure 24. Ensure pump electrical cables can reach the ROWPU power receptacles on the junction box.

Figure 24. Typical ROWPU Equipment Layout.

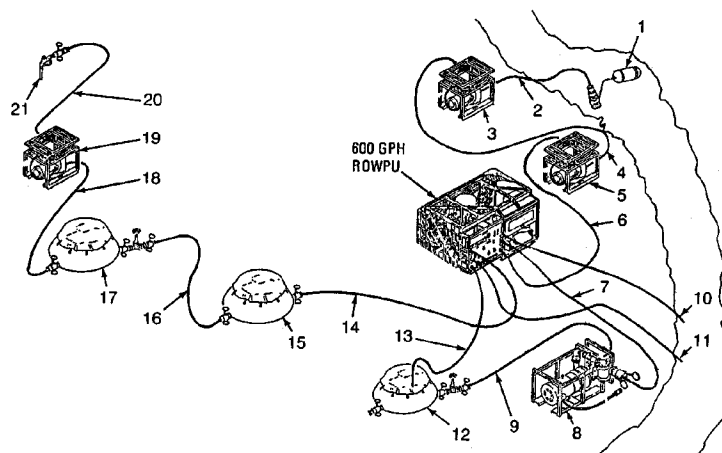

- | | |
|--|--|
| 1. Raw water strainer and float | 12. Backwash water tank |
| 2. Up to three 1 1/2-inch suction hoses | 13. 1 1/2-inch fabric brine discharge hose |
| 3. Raw water pump No. 1 | 14. 1 1/2-inch discharge |
| 4. One 1 1/2-inch canvas discharge hose | 15. Product water tank |
| 5. Raw water pump No. 2 | 16. Product 1 1/2-inch discharge hose |
| 6. Two 1 1/2-inch canvas discharge hoses | 17. Product water tank |
| 7. 2-inch canvas Backwash discharge hose | 18. Product water 1 1/2-inch suction hose |
| 8. Backwash pump | 19. Distribution pump |
| 9. 2-inch Backwash suction hose | 20. Product water 1 1/2-inch canvas discharge hose |
| 10. 2-inch fabric Waste water discharge hose | 21. Distribution nozzle |
| 11. 2-inch Vent Vessels discharge hose | |

Connect raw water system components (figure 25). Use the minimum number of hose lengths from the ROWPU to the source. Concentrate on minimizing the length of hoses between the ROWPU and pump #2 and between pump #1 and the source.

Figure 25. Raw Water System Layout

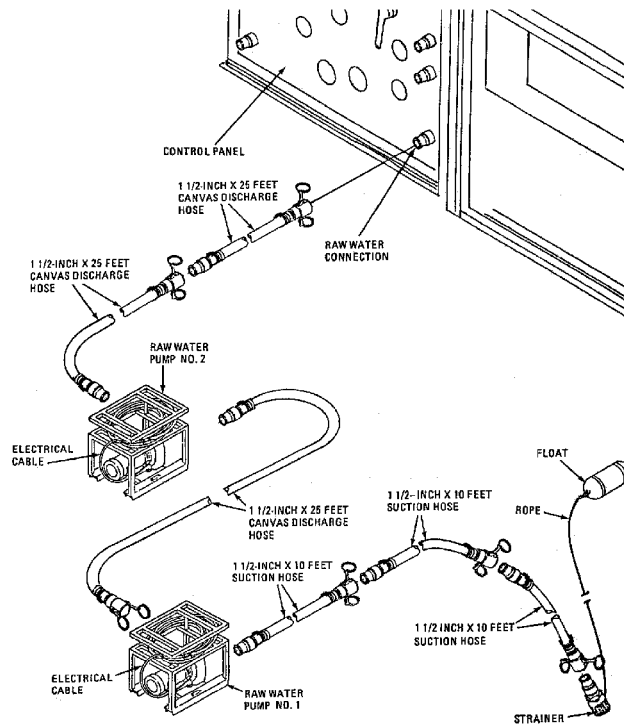

Connect canvas discharge hoses between the RAW WATER coupling on the ROWPU control panel and discharge coupling of raw water pump #2.

Connect canvas discharge hose between the suction coupling of pump #2 and the discharge coupling of pump #1.

Connect three hard rubber suction hoses to the suction coupling of raw water pump #1.

Connect strainer to the end of the hard rubber suction hoses.

Connect float to strainer. Use enough rope to permit the strainer to go under water but not rest on the bottom.

Place float and strainer in the water source.

Connect electrical cable from raw water pump #2 to RAW WATER PUMP NO. 2 receptacle on ROWPU junction box (figure 26). Place electrical cables under hoses to reduce tripping hazards

Connect electrical cable from raw water pump #1 to RAW WATER PUMP NO. 1 receptacle on ROWPU junction box (figure 26). Place electrical cables under hoses to reduce tripping hazards.

Figure 26. Electrical Connections from Raw Water Pumps to ROWPU.



Connect backwash water system components (figure 27).

Figure 27. Backwash System Layout.

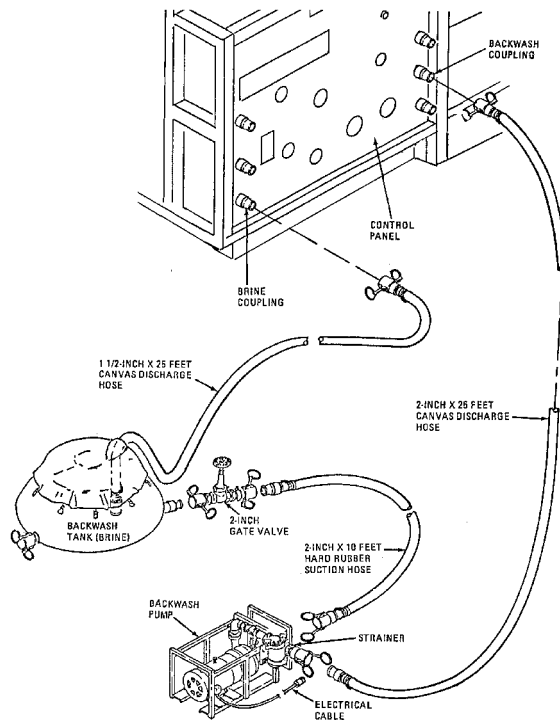

Connect canvas discharge hose between BACKWASH coupling on the ROWPU control panel and the discharge coupling on the backwash pump strainer.

Connect backwash pump electrical cable to BACKWASH PUMP receptacle on the ROWPU junction box. Run electrical cable under hoses when appropriate.

Connect hard rubber suction hose to suction coupling on backwash pump.

Connect the 2-inch gate valve to the suction hose.

Set up the backwash brine tank and connect the gate valve to it. Make sure you clear the ground of all debris or material that could cause tank puncture and use the ground cloth under the tank. Also use the tank cover. Inflate the tank collar and cover float before filling the tank.

Connect canvas discharge hose to the BRINE coupling on the ROWPU control panel and place the other end of the hose in the brine tank. Make sure the cap is removed from the end of the hose in the brine tank and the hose is secured in place using the tank cover.

Connect product water system components (figure 28). Use blue striped hose for all hose runs.

Connect 2-inch female x 1 ½-inch male adapters to both product water tanks.

Connect a canvas discharge hose to PRODUCT WATER coupling on the ROWPU control panel. Place and secure end of canvas hose in product water tank #1.

Connect a discharge hose and 1 ½-inch gate valve between product water tanks #1 and #2.

Connect suction hose between product water tank #2 and the suction coupling on the distribution pump.

Figure 28. Product Water System Layout.

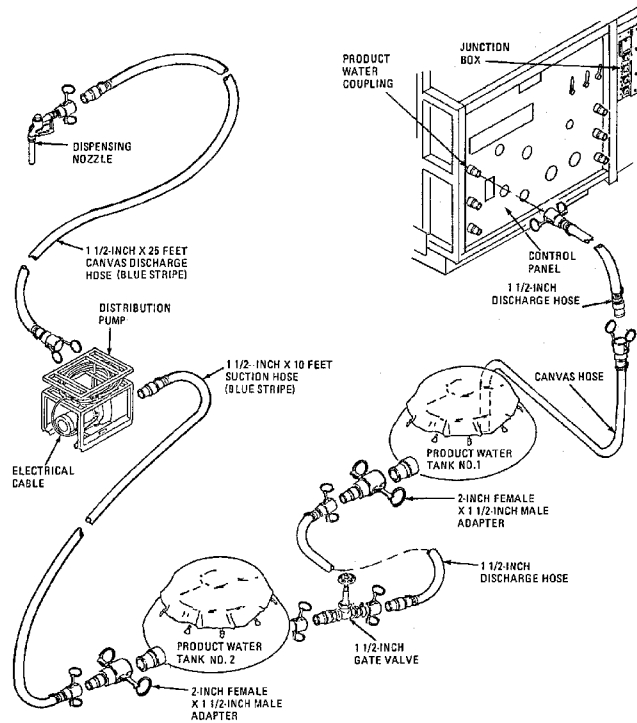

Connect one canvas discharge hose and dispensing nozzle to discharge coupling on the distribution pump (once the distribution system components arrive you will be connecting the product water output lines to several interconnected storage bladders).

Connect electrical cable from distribution pump to DISTRIBUTION PUMP receptacle on ROWPU junction box.

Assemble waste water system components (figure 29) (do not use blue striped hoses).

Attach canvas discharge hose to VENT VESSELS coupling on ROWPU control panel. Place the free end of the hose as far away from the ROWPU as possible and ensure it is at least 25 yards downstream of the water source intake.

Attach canvas discharge hose to WASTE coupling on ROWPU control panel. Place the free end of the hose as far away from the ROWPU as possible and ensure it is at least 25 yards downstream of the water source intake.

Figure 29. Waste Water System Connections.

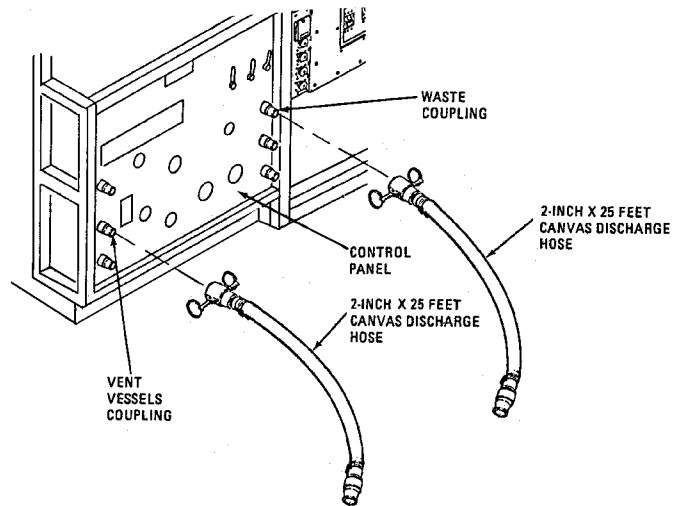

Prepare chemical solutions. Wear appropriate safety gear when handling and mixing chemicals. Use only chlorine free water for mixing chemicals to prevent damage to ROWPU elements. If this is the first time the ROWPU is being started, use raw water to mix chemicals. If you are restarting the unit, use brine water.

Gather chemicals, pails, measuring and mixing tools, and safety clothing and equipment.

Label four of the pails and four of the paddles POLYMER, SODIUM HEX, CHLORINE and CITRIC ACID.

Mix polymer as follows:

Fill Polymer beaker half full with liquid polymer chemical.

Pour liquid polymer into pail marked POLYMER.

Add brine or raw water to POLYMER pail up to the three-gallon mark.

Stir pail with wooden paddle for at least one minute.

Pour solution into chemical feed can marked POLYMER.

Mix chlorine solution as follows:

Pour three gallons of brine or raw water into unmarked pail (do not use this pail for anything else).

Fill CALCIUM HYPOCHLORITE beaker with 0.2 pounds of calcium hypochlorite.

Pour brine or raw water from unmarked pail into CHLORINE pail.

Pour calcium hypochlorite into pail marked CHLORINE.

Stir pail with wood paddle for one minute.

Pour chlorine solution into chemical feed can marked CHLORINE.

Mix sodium hexametaphosphate solution as follows:

Pour 0.1 pounds of sodium hex into SODIUM HEX beaker.

Pour sodium hex into pail marked SODIUM HEX.

Add brine or raw water to pail marked SODIUM HEX. Fill to three- gallon mark.

Stir pail with wood paddle for one minute.

Pour solution into chemical feed can marked SODIUM HEX.

Check chemical feed can solution levels by loosening the cap on the indicator, and then gently letting go. Indicators should remain raised approximately $\frac{1}{4}$ the length of the indicator ($\frac{1}{4}$ full). Make sure the lids are installed on the feed cans and vents are open.

Connect chemical feed cans (figure 30).

Position chemical feed can rack next to chemical feed pump stand. Locate the set of flexible tubes having blue connecting sleeves.

Remove the caps and plugs from the couplings on the flexible tubes with the blue connecting sleeves and the couplings on the POLYMER feed can.

Figure 30. Chemical Feed Can Connections.



Connect the tube with the female coupling to the male coupling on the feed can. This is the suction line from the feed can.

Connect the tube with the male coupling to the female coupling on the feed can. This is the return line.

Connect the flexible tubes with the green sleeves onto the SODIUM HEX feed can.

Connect the flexible tubes with the red sleeves onto the CHLORINE feed can.

Connect the flexible tubes with the yellow sleeves onto the CITRIC ACID feed can.

Install ground rod.

Remove ground rod assembly from front of ROWPU control panel.

Ensure drive bolt is screwed into the coupler on the end of the first ground rod section. Drive this section into the ground until only six inches of the rod remain above ground.

Attach a second ground rod section to the first. Screw coupler with drive bolt onto the other end of the second ground rod section and drive it until six inches remains above ground.

Attach the third section to the second and repeat the process until eight feet of rod are into the ground.

Attach grounding cable to GROUND lug on ROWPU (located on the R.O. tube side of the unit, lower right hand corner on the frame).

Attach other end of cable to the ground rod using the ground rod clamp.

If ground conditions prohibit driving the ground rod eight feet, try a horizontal ground installation—see AFH 10-222, Volume 5, Guide to Bare Base Power Plant Installation, for an example. Your electrical personnel should already be acquainted with the procedure.

Connect power to ROWPU. ROWPUs normally are fed 208 volt, three-phase power from the Harvest Falcon electrical distribution system. Two incoming power feeds are required. One will power the R.O. pump motor, the second powers the remaining system components and accessories. These power feeds are connected to the J1 and J10 receptacles located on the bottom of the junction box (figure 31). If a separate generator is to be used to power the ROWPU, a 30kW unit will be required. If a separate generator is used, be sure to wear ear protection when working near the unit.

Figure 31. Electrical Power Connections at Junction Box.



Pre-operating Adjustments and Checks

Before ROWPU operation can begin, several switches and valves have to be set correctly.

Close all seven drain valves (figure 32).

Open vent valves

Set VENT CARTRIDGE FILTER valve on control panel to OPEN.

Set VENT PULSE DAMPENER valve on control panel to OPEN.

Set VENT MULTIMEDIA FILTER valve on control panel to OPEN.

Fully open VENT VESSELS gate valve located behind control panel (figure 33).

Set VENT PRODUCT WATER valve (figure 34) to open. Valve is open when handle is pointing down.

Set backwash valve handle on control panel to NORMAL.

Set REGULATE PRODUCT FLOW valve on control panel to OPEN.

Close the four front R.O. pressure tube vent/sample valves (figure 35). Valves are closed when handles are horizontal.

Set the four rear R.O. pressure tube vent/sample valves (figure 36) to normal position. Handles on these valves are horizontal when in the normal position.

Check position of switches on the control box assembly on the control panel. All switches with a STOP label should be set in the STOP position. Leave BACKWASH switch in the RUN position.

Make sure the EMERGENCY STOP button on the control box assembly is pulled out.

Figure 32. Drain Valves.



Figure 33. VENT VESSELS Gate Valve.



Figure 34. VENT PRODUCT WATER Valve.



Figure 35. Front R.O. Pressure Tube Vent/Sample Valves.

Ensure ELEMENT CLEANING switch is in the OFF position.

Set all chemical feed run/prime valves to PRIME (figure 37).

Prime raw water pumps.

Verify that the raw water strainer is underwater.

Ensure drain and vent valves on raw water pump #1 are closed.

Remove priming plug from top of raw water pump #1 and fill pump housing with raw water. Replace plug.

Figure 36. Rear R.O. Pressure Tube Vent/Sample Valves.



Figure 37. Chemical Feed Run/Prime Values in PRIME Position.



OPERATION

ROWPU operation is a very methodical process and must be performed in a precise order. Take the time to review the technical order cautions and warnings, and refresh yourself on emergency shutdown procedures and when they should be applied. Damage of water production equipment during a contingency operation could very well jeopardize the ability of an air base to support sustained operations. Basic ROWPU operational procedures are as follows:

Apply electrical power to ROWPU and accessories by opening the junction box circuit breaker cover and placing circuit breakers CB-1 through CB-9 in the on position.

Ensure the EMERGENCY STOP button on the control box is pulled out.

Push PANEL LIGHT switch on the control box to TEST INDICATOR LIGHTS position. Check all lamps and adjust brightness as necessary.

Start raw water pump #1 by holding the RAW WATER PUMP #1 switch up in the START position until the RAW WATER PUMP #1 lamp comes on. Release switch (switch will go to RUN position) and visually check the discharge hose leading from pump to ensure water is flowing.

Start raw water pump #2 by holding the RAW WATER PUMP #2 switch up in the START position until the RAW WATER PUMP #2 lamp comes on. Release switch (switch will go to RUN position) and visually check the raw water discharge hose connected to the RAW WATER coupling on the control panel to ensure water is flowing.

Check RAW WATER FLOW gage on the control panel—it should read between 27 and 40 gpm.

Start chemical feed pump by holding the CHEMICAL FEED PUMP switch up in the START position until the CHEMICAL FEED PUMP lamp comes on. Release switch.

Adjust chemical feed pump.

Turn all four chemical feed pump control knobs to 10 (figure 38).

With controls set at 10 and RUN/PRIME valves set to PRIME, allow the chemical feed pump to operate until solution is flowing in all chemical feed hoses.

Adjust polymer flow. Control knob settings in the below procedures are for example only, you may have to use different settings to obtain proper chemical flow.

For turbid source water, set POLYMER control knob on the chemical feed pump to 2. For clear source water, set POLYMER control knob to 1.

Figure 38. Chemical Feed Pump Controls.



With the chemical feed pump operating, disconnect the return line from the POLYMER tank and flow the POLYMER into a 100ml cylinder for one minute. Measure the amount of POLYMER in the cylinder.

If the POLYMER control knob was set to 2 for turbid water, POLYMER flow should be about 60 ml/min. If set to 1 for clear water, the flow should be at least 20 ml/min. If the rate of flow is too high, turn the control knob clockwise to reduce flow. If flow rate is too low, turn the control knob counterclockwise.

Repeat the above steps until flow rate is correct. Once flow rate is proper for the type of source water, reconnect the return line to the POLYMER can and record the POLYMER control knob setting for future use.

Adjust SODIUM HEX flow.

Set SODIUM HEX control knob on chemical feed pump to 3.

With the chemical feed pump operating, disconnect the return line from the SODIUM HEX tank and flow the SODIUM HEX into a 100ml cylinder for one minute. Measure the amount of SODIUM HEX in the cylinder.

SODIUM HEX flow should be about 60 ml/min. If the rate of flow is too high, turn the SODIUM HEX control knob clockwise to reduce flow. If flow rate is too low, turn the control knob counterclockwise.

Repeat the above steps until the SODIUM HEX flow rate is proper. Reconnect return line to SODIUM HEX can once flow tests are completed.

Adjust CHLORINE flow. Use the same procedures for CHLORINE flow rate determination as were used for SODIUM HEX.

Leave CITRIC ACID control knob at maximum setting and leave the corresponding RUN/PRIME valve in the PRIME position.

With both raw water pumps working, and the chemical feed pump running, set the POLYMER chemical feed RUN/PRIME valve to RUN.

Vent the multimedia filter.

Set VENT MULTIMEDIA FILTER valve, VENT PULSE DAMPENER valve, and VENT CARTRIDGE FILTER valve to CLOSE. All three valves are located on the control panel.

Set VENT MULTIMEDIA FILTER valve to OPEN.

Set VENT MULTIMEDIA FILTER valve to CLOSE as soon as a steady stream of water flows out of the vent pipe located below the R.O. pump belt guard (figure 39). You will probably hear air venting from this pipe prior to water flow.

Start booster pump.

Set VENT CARTRIDGE FILTER valve to OPEN.

Push BOOSTER PUMP switch on the control box up to START and hold until BOOSTER PUMP lamp comes on. Release switch and allow it to stay in the RUN position.

Set VENT CARTRIDGE FILTER valve to CLOSE as soon as a steady stream of water flows out of the vent pipe below the R.O. pump screen belt guard.

Figure 39. Vent Pipe for the Three Vent Valves.



Start reverse osmosis pump.

Ensure VENT VESSELS gate valve (figure 33) and REGULATE PRODUCT FLOW valve on control panel are open.

Set VENT PULSE DAMPENER valve to OPEN.

Push R.O. PUMP RESET switch on control box up. The R.O. PUMP LOW PRESSURE lamp should go off. Allow the switch to return to the ON position.

Push R.O. PUMP switch on control box up to START. Hold switch until R.O. PUMP lamp comes on, then release switch. Allow switch to return to RUN.

Set VENT PULSE DAMPENER valve to CLOSE as soon as a steady stream of water flows out of the vent pipe.

Observe end of VENT VESSELS hose (figure 29) for water flow and clarity. Water should start becoming clearer. After 10 minutes or as soon as water appears completely clear, proceed with clarity testing.

Examine clarity of filtered water.

Obtain the 1000 ml graduated cylinder and go to the drain valves below the R.O. tubes (figure 32).

Slowly open DRAIN #1 CARTRIDGE FILTER valve and allow water to flow for 20 to 30 seconds. Draw a 600 ml sample then close the valve.

Look down through the sample to the bottom of the cylinder to see whether the bullseye at the bottom of the cylinder can be seen clearly. If the bullseye cannot be seen clearly, run the ROWPU another 10 minutes and repeat the above clarity testing regimen.

If after the second sampling the bullseye still cannot be seen clearly, increase the chemical feed pump POLYMER control knob by two index marks. Run the ROWPU for another 5 minutes and take another sampling check.

Repeat the above step until the bullseye can be clearly seen at the bottom of the 1000 ml cylinder. For information, unless the water is unusually turbid, you should not have to raise the POLYMER setting above 5.

Make final system adjustments.

Set the SODIUM HEX RUN/PRIME valve in the RUN position.

Check that the VENT PRODUCT WATER valve (figure 34) is in the open position.

Check that the REGULATE PRODUCT FLOW valve on control panel is fully open.

Slowly close the VENT VESSELS gate valve (figure 33) to allow filtered water to enter the R.O. vessels.

Slowly adjust REGULATE PRODUCT FLOW valve to the right. Watch for an increase in PRODUCT WATER FLOW gauge, a decreased flow in BRINE FLOW gauge, and increased pressure in the R.O. PRESSURE PSI gauge. All three of these gauges are on the control panel. Close the REGULATE PRODUCT FLOW valve very carefully—pressure in the R.O. tubes raises rapidly as the valve comes nearer to being closed. Watch the gauges until the proper balance as displayed in table 8 is obtained.

Close VENT PRODUCT WATER valve when no air bubbles are seen in the PRODUCT WATER FLOW meter on the control panel and a steady stream of water is coming out of the vent pipe.

Set CHLORINE RUN/PRIME valve to the RUN position.

The ROWPU is now in full operation. Keep an eye on the various chemical readings: total dissolved solids of the product water should be less than 1000 ppm (never more than 1500 ppm), chlorine residual should be 5 ppm and the pH should be between 5 and 9. The 5 ppm is on the high side; check with the hospital staff for clarification and direction on chlorine residual levels.

Fill backwash (brine) tank. During operation of the ROWPU, brine water is constantly produced. A small portion of this brine discharge is saved for backwashing filters and cleaning the R.O. elements. The brine leaves the ROWPU through the BRINE coupling on the control panel. Fill the brine tank to within 3 inches of its top. Once full, the brine discharge hose is removed from the tank and the brine is discharged back to the source or

otherwise away from the water plant area. As brine is used for cleaning and backwashing, keep refilling the storage tank.

Table 8. Normal and Problem-Point Gauge Indications.

Gauge/Indicator	Normal Reading	Problem-Point Reading
CARTRIDGE FILTER	0-20 psid	Over 20 psid
MULTIMEDIA FILTER	10 psid or less	Over 10 psid
RAW WATER FLOW	27-40 gpm	25gpm or less
BRINE FLOW	16-24 gpm	Below 15 gpm
PRODUCT WATER FLOW:		
SALT WATER	6-12 gpm	Below 6 and above 12 gpm
FRESH WATER	Up to 16 gpm	Above 16 gpm
BRACKISH WATER	Up to 16 gpm	Above 16 gpm
R.O.PRESSURE PSI:		
SALT WATER	Not to exceed 960 psig	Above 960 psig
FRESH WATER	Not to exceed 500 psig	Above 500 psig
BRACKISH	Not to exceed 500 gpm	Above 500 psig
R.O. VESSELS	50-100 psid	Above 100 psid
TDS OF PRODUCT WATER	Below 1000 ppm	1500 ppm or above

Fill product water tanks. As product water is generated, it is stored in the two onion tanks in the product water system prior to being pumped by the distribution pump to large storage bladders or dispensing points. When setting up the product water system, ensure that tank #2 is at the same level or lower than tank #1. Since the system is essentially gravity flow prior to reaching the distribution pump, tank #2 will not fill if it is at a higher elevation than tank #1. If the tanks are at the same level, both will basically

fill at the same rate. If tank #2 is lower, fill it first. Then close the gate valve on the supply side of tank #2 and fill tank #1. If you are only operating a basic ROWPU package, once the tanks are full you can shutdown the ROWPU until more water is needed. In most cases, however, you will be supplying a sizable population and have the Harvest Falcon or Eagle water distribution package to operate with. It is probable you will be running an around-the-clock operation and ROWPUs will be shut down only for maintenance purposes. Lastly, remember to only discharge properly treated water into the product water system. If the total dissolved solids level is too high (>1500 ppm) or the chlorine residual too low, don't "contaminate" your system by flowing such water into it.

Water distribution. In its most simple form water distribution isn't much more than operating the distribution pump to flow water to dispensing points for the user.

Set DISTRIBUTION PUMP switch on the control box to START.
Dispense water as required. Stop pump by setting pump switch to STOP.

Monitor water production operation. During ROWPU operations you will need to keep track of chemical additions to the water being processed, particularly polymer and chlorine dosages.

Check polymer dosage by performing the same tests discussed earlier under examining the clarity of filtered water. Take your sample from the DRAIN #1 CARTRIDGE FILTER valve, use the 1000 ml cylinder, and check for visibility of the bullseye at the bottom of the tube. Perform this clarity test hourly and record the chemical feed pump POLYMER control knob setting in your log.

Another test to be performed hourly is the chlorine residual test of the product water using the color comparator kit. If the residual is less than 5 ppm, increase the chemical feed pump CHLORINE control knob setting two marks (again, check with the hospital staff for chlorine

residual requirements at your location). Wait five minutes and take the residual reading again. If the reading is still too low, increase the control knob setting once again and repeat the test after five minutes. Continue performing this process until the proper chlorine residual level is obtained. Keep track of the readings and settings in your operator's log book.

Monitor the R.O. PUMP LOW PRESSURE and HIGH PRESSURE lamps on the control box. Both should be off during normal operation. If either lamp comes on, shut down the ROWPU immediately and consult the technical order for troubleshooting actions.

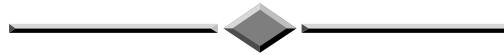

KEY MAINTENANCE ACTIVITIES

Backwash of the Multimedia Filter

To keep the multimedia filter in operating order, periodic backwashing of the filter is necessary. During this process water flow is reversed so that it flows from the bottom to the top of the filter tank. The operation is controlled by a solid state timer (figure 40) mounted on the end of the ROWPU adjacent to the control panel. If one of the following criteria is met, backwashing of the filter should be performed:

- ROWPU has been operating for 20 hours
- Multimedia filter gage reading is over 10 psid
- Multimedia filter gage reading exceeds 5 psid above log reading at startup
- ROWPU will be shutdown for more than 24 hours

Figure 40. Solid State Backwash Timer.



Once the initial unit preparatory actions are completed and the backwash valve is set to BACKWASH, the backwash timer comes on and controls the backwash process automatically. To backwash the multimedia filter take the following steps:

Perform normal shutdown of the ROWPU (addressed in latter section of this handbook).

Ensure the R.O. ELEMENT CLEANING switch (figure 41) on the side of the control panel is in the off position.

Ensure brine water tank is full.

Ensure strainer on backwash pump is clear.

Open the gate valve between backwash tank and backwash pump.

Figure 41. R.O. Element Cleaning Switch.



Loosen vent plug on top of backwash pump. When steady stream of water comes from around the plug, tighten the plug.

Turn BACKWASH VALVE handle on control panel downward to BACKWASH.

Push BACKWASH switch on control box up to START position and release immediately. The timer will come on, BACKWASH PUMP ON lamp will light and brine water will be pumped up through the multimedia filter and out of the WASTE water hose. The MULTIMEDIA FILTER gauge needle on the control panel will move to full right. Total backwash operation will last about 13 minutes.

When backwash is complete, the BACKWASH PUMP ON lamp will go off. After the pump shuts off, move the BACKWASH VALVE handle up to the NORMAL position.

Close the gate valve between the backwash tank and the backwash pump.

Perform normal ROWPU startup after backwash. Flush the multimedia filter with raw water for five minutes.

Citric Acid Feed

After 20 hours of continuous operation or when pH of brine water rises above 8, citric acid should be fed into filtered water to remove minor amounts of scale which accumulate during normal operation. Procedures are as follows:

Don safety gear appropriate to handling ROWPU chemicals.

Using citric acid measure, put $\frac{3}{4}$ pound of citric acid in the pail marked CITRIC ACID. Fill pail with 3 gallons of brine water.

Stir chemical and brine water with wooden paddle labeled CITRIC ACID.

Remove lid from CITRIC ACID chemical feed can and carefully add the acid solution into the can.

Install lid on chemical feed can and ensure vent cap is open.

Set CITRIC ACID chemical feed pump control knob to 10.

While ROWPU is running normally, set the CITRIC ACID RUN/PRIME valve to RUN.

Allow unit to operate 10 minutes.

Draw a 250-ml water sample from brine hose at backwash tank and check for a pH reading of 5 to 8. If pH reading is over 8, repeat the above steps using 1 ½ pounds of citric acid mixed with three gallons of brine water.

Once you get a pH reading between 5 and 8 the citric acid feed can be considered complete. Set the CITRIC ACID RUN/PRIME valve to PRIME.

R.O. Element Cleaning

R.O. elements will need to be periodically cleaned so that dissolved solids can be removed most effectively and operating pressures on the system are reduced. Indicators that element cleaning is needed are:

R.O. VESSELS gage shows over 100 psid

Product water total dissolved solids reading is high (over 1000)

R.O.PRESSURE PSI gage indicates 960 psi and PRODUCT WATER FLOW gage indicates less than 6 gpm (salt water)

R.O.PRESSURE PSI gage indicates 500 psi and PRODUCT WATER FLOW gage indicates less than 10 gpm (fresh/brackish water)

Two methods of cleaning the elements are commonly used. The first method, used to remove mineral deposits, feeds a citric acid solution through the R.O. vessels. The second method, used to remove dirt and silt, feeds a surfactant (soapy) cleaning solution through the vessels.

Citric Acid Method

Backwash the multimedia filter.

Disconnect backwash water inlet hose (hose between backwash pump and ROWPU control panel) from control panel and place down stream from source inlet (at least 25 yards). Open brine tank gate valve.

Push ELEMENT CLEANING switch (figure 41) up to START.

When water in the backwash tank drops to seven inches, set the ELEMENT CLEANING switch to OFF and close brine tank gate valve. Use the seven inch mark on the mixing paddle as a guide to measure water depth in the backwash tank.

Reconnect the backwash water inlet hose back onto the BACKWASH coupling on the control panel.

Mix one full pail (about 35 pounds) of citric acid to water in backwash water tank and stir until all granules are dissolved.

Disconnect backwash hose from backwash pump strainer, place end of hose at least 25 yards downstream from source inlet.

Connect free end of vent vessels hose to backwash pump strainer.

Ensure REGULATE PRODUCT FLOW valve on control panel is open.

Ensure VENT VESSELS gate valve is open.

Open gate valve between backwash tank and backwash pump.

Remove product water hose from product water tank and place it in an expediently constructed lagoon.

Ensure brine water hose is placed back into backwash water tank.

Start element cleaning. Push ELEMENT CLEANING switch up to START position, then release. Switch should automatically go to RUN position.

Check BRINE FLOW indicator on control panel; it should show a flow of 16 gpm or more.

After five minutes of operation, check pH of water discharging back into the brine tank. The pH should be near but not below 3.5. If it is not, stir in another pound of citric acid to the brine tank. Continue checking pH and adding one pound amounts of citric acid at five-minute intervals until pH approaches but does not fall below 3.5.

Allow the citric acid solution to circulate for 45 minutes. Periodically check the temperature of the water discharging back into the brine tank. If the temperature rises above 120 degrees, stop circulating the acid solution immediately.

Once the 45 minutes of circulation has been reached, stop the circulation by pushing the ELEMENT CLEANING switch down to OFF.

Disconnect the VENT VESSELS hose from the control panel and place it in the lagoon. Push the ELEMENT CLEANING switch to START.

When the backwash tank has been emptied, push ELEMENT CLEANING switch to OFF.

Reconnect vent vessel hose to the VENT VESSELS coupling on the control panel. Disconnect vent vessels hose from backwash pump strainer and place the end of the hose at least 25 yards downstream from source inlet.

Reconnect backwash hose to backwash pump strainer.

Remove brine hose from backwash tank and allow it to drain on the ground.

Perform normal ROWPU startup. Operate the unit for 10 minutes with brine and product water hoses out of tanks and REGULATE PRODUCT FLOW valve fully open to rinse the R.O. pressure tubes.

Disconnect suction hose from backwash pump inlet.

Place brine hose in backwash tank to flush citric acid residue from tank and suction hose.

Close gate valve between backwash tank and backwash pump.

Reconnect backwash pump suction hose to backwash pump when hose is clean.

Adjust REGULATE PRODUCT FLOW valve on control panel until PRODUCT WATER FLOW gage indicates under 16 gpm (fresh/brackish water) or 12 gpm (salt water) and R.O. PRESSURE PSI gage indicates under 500 (fresh/brackish water) or 960 (salt water).

Close VENT PRODUCT WATER valve.

Allow ROWPU to run three minutes to flush citric acid from product water hose. Check product water total dissolved solids with the TDS meter. If TDS is over 1000 ppm after cleaning, run the ROWPU longer. Be aware it may take you hours of operation to lower the TDS count to below 1000 ppm.

Once the TDS reading is below 1000 ppm, turn CHLORINE PRIME/RUN valve to RUN. Wait five minutes, then perform chlorine residual and pH tests.

When chlorine residual and pH are within required limits, place the product water line back in the product water tank and resume normal water production operations.

Surfactant (detergent) Method

Backwash the multimedia filter.

Disconnect backwash water inlet hose (hose between backwash pump and ROWPU control panel) from control panel and place down stream from source inlet (at least 25 yards). Open brine tank gate valve.

Push ELEMENT CLEANING switch up to START.

When water in the backwash tank drops to seven inches, set the ELEMENT CLEANING switch to OFF and close brine tank gate valve. Use the seven inch mark on the mixing paddle as a guide to measure water depth in the backwash tank.

Reconnect the backwash water inlet hose back onto the BACKWASH coupling on the control panel.

Using the 1000 ml graduated cylinder, measure 2160 ml of surfactant and pour into backwash tank. Stir to mix thoroughly.

Disconnect backwash hose from backwash pump strainer, place end of hose at least 25 yards downstream from source inlet.

Connect free end of vent vessels hose to backwash pump strainer.

Ensure REGULATE PRODUCT FLOW valve on control panel is open.

Ensure VENT VESSELS gate valve is open.

Open gate valve between backwash tank and backwash pump.

Remove product water hose from product water tank and place it in an expediently constructed lagoon.

Ensure brine water hose is placed back into backwash water tank.

Start element cleaning. Push ELEMENT CLEANING switch up to START position, then release. Switch should automatically go to RUN position.

Check BRINE FLOW indicator on control panel; it should show a flow of 16 gpm or more.

Once the 45 minutes of circulation has been reached, stop the circulation by pushing the ELEMENT CLEANING switch down to OFF.

Disconnect the VENT VESSELS hose from the control panel and place it in the lagoon. Push the ELEMENT CLEANING switch to START.

When the backwash tank has been emptied, push ELEMENT CLEANING switch to OFF.

Reconnect vent vessel hose to the VENT VESSELS coupling on the control panel.

Disconnect vent vessels hose from backwash pump strainer and place the end of the hose at least 25 yards downstream from source inlet.

Reconnect backwash hose to backwash pump strainer.

Remove brine hose from backwash tank and allow it to drain on the ground.

Perform normal ROWPU startup. Operate ROWPU until suds are no longer coming out of brine water.

Adjust REGULATE PRODUCT FLOW valve until PRODUCT WATER FLOW gage indicates under 16 gpm (fresh/brackish water) or 12 gpm (salt water), and R.O. PRESSURE PSI gage indicates 500 (fresh/brackish water) or 960 (salt water).

Close VENT PRODUCT WATER valve.

Allow ROWPU to operate until suds are no longer coming out of product water hose. Check product water total dissolved solids.

After obtaining total dissolved solids level under 1000 ppm, turn CHLORINE PRIME/RUN valve to RUN.

Wait five minutes, then perform chlorine residual and pH test. When chlorine residual and pH are within limits, place product water line back into product water tank.

Cartridge Filter Tube Replacement

Changing of cartridge filter tubes is necessary when the CARTRIDGE FILTER gage differential pressure rises above 20 psid. To change out the filters, the ROWPU must be shutdown and cartridge filter drains 1 and 2 (figure 42) must be open. Procedures for filter change-out follow:

Figure 42. Cartridge Filter Drains #1 and #2.

Unzip access hole in top of canvas cover.

Disconnect hose from coupling on the filter cover. Mark position of cover on the cartridge filter shell to ease installation later.

Loosen the six eyebolts and rotate them out of the notches in the filter cover (figure 43). The bolts are under spring tension, loosen them a few turns at a time in an alternating pattern.

Remove filter cover. Remove and discard the eight filter tubes.

Install eight new filter tubes (figure 44) ensuring they are properly seated in the bottom the shell.

Inspect the packing ring for serviceability. If okay, lubricate the packing with silicon grease.

Position the filter cover on the shell and align the marks made earlier. Ensure filters are seated correctly in the cover.

Figure 43. Cartridge Filter Cover Removal.



Figure 44. Cartridge Filter Tube Replacement.



Rotate eyebolts into position and alternately hand tighten in the order shown in figure 45. Connect hose to the top coupling. Close access hole in canvas cover.

Operate ROWPU and check for leaks.

Figure 45. Eyebolt Tightening Sequence.

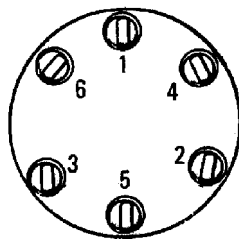

R.O. Element Replacement

R.O. elements are replaced when total dissolved solids of the product water exceed 1000 ppm and cannot be corrected using the troubleshooting techniques outlined in the ROWPU technical order (these generally involve replacing packing materials). To perform the element replacement, the ROWPU must be shutdown and the R.O. vessels drained. Set the front sample valves (figure 35) to open and the rear sample valves (figure 36) to sample position to drain the R.O. vessels. The R.O. vessels vent valve must also be open.

Always remove and install elements in the direction of water flow (figure 46). Procedures for replacing the elements follow:

Mark end caps to indicate from what pressure tube and which end the caps come from. Also make alignment marks on the caps and tubes to ensure replacement in the same position.

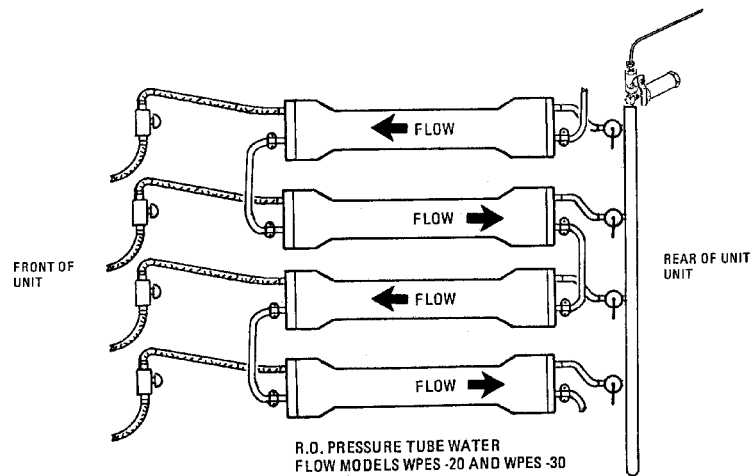
Figure 46. R.O. Pressure Tube Water Flow.

Loosen the hose clamp on the hose connected between the end cap and the sample valve (figure 47). Disconnect the hose.

Remove the clamp on the piping leading to the end cap (figure 47). Swing this elbow piping out of the way.

Remove the nuts and washers from the studs (figure 47).

Screw the four cap puller bolts into the threaded holes in the end cap. Turn these four bolts alternately until end cap is separated from the pressure tube. Remove the end cap. Repeat the above procedures to remove the end cap from the other end of the pressure tube.

Screw element puller rod handle onto puller rod (figure 48).

Figure 47. End Cap Details.

Push puller rod assembly through the center of the first end connector, R.O. element, interconnector, second R.O. element and out through the second end connector (figure 49). Secure puller plate on the end of the puller rod (figure 48). Double check to ensure you will be pulling elements out in the direction of product water flow.

Slowly pull the R.O. element string out from the tube. Have a second person support the element string as it is pulled out to keep the puller rod centered in the pressure tube. Once the elements are out, disassemble the puller rod and remove it from the element string.

With one person at each end of the R.O. element string, twist and pull the two elements apart. Next remove the end connectors and interconnector from the elements.

Figure 48. Puller Rod Components.



Figure 49. Puller Rod Inserted into R.O. Element String.



Clean the inside of the pressure tube with brine water. Also clean the end connectors and interconnector with a clean cloth. Check the end connectors, interconnector and all preformed packings (figure 50) for serviceability.

Remove puller bolts from end cap.

Lubricate all preformed packings with silicon grease. There are two sizes of preformed packings, one only slightly smaller than the other. The smaller packings go on the outside ends of the end connectors. The larger packing rings go on the inside ends of the end connectors (the element side) and both ends of the interconnector.

If existing packings had to be removed due to poor serviceability, replace packings, as necessary, on the end connectors and interconnector.

Obtain new element. Lubricate brine seal on the element and insert the element into the pressure tube until the brine seal makes contact with the end of the pressure tube (figure 51). Note that the brine seal faces opposite the direction of water flow—this must always be the case.

Figure 50. R.O. Element String Details.

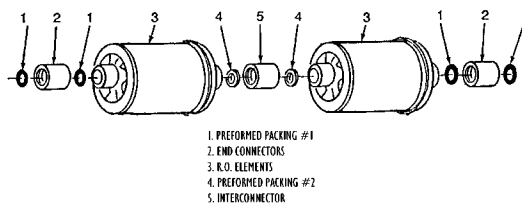

Figure 51. Insertion of R.O. Element into Pressure Tube.



Attach interconnector to the element

Obtain second R.O. element. Lubricate its brine seal and connect this second element to the interconnector already attached to the first element. Ensure the brine seal faces opposite the direction of water flow.

Slide both elements and their interconnector into the pressure tube until they are centered. Place end connectors on both elements.

Lubricate the preformed packing on one of the end caps with silicone grease.

Align the cap with the pressure tube using the marks made earlier and push it into place. As cap is being pushed on the pressure tube, ensure it also connects to the end connector on the adjacent R.O. element.

Push on end cap until it is seated on the studs and alignment marks match up. Loosely install the washers and nuts on the studs.

Slowly tighten each nut until snug. Never turn one nut more than two turns at a time. Keep alternating from nut to nut until all have been tightened. When all are hand tightened, turn each one 1/8 of a turn with a wrench.

Place gasket on coupling extending from end cap. Swing elbow piping back up into position over the gasket and coupling. Install clamp back on piping.

Connect hose to adapter using the adjustable clamp.

Install end cap on other end of pressure tube.

Start ROWPU and check all connections for leaks.



SHUTDOWN PROCEDURES

As mentioned in the maintenance section previously, the ROWPU must be shutdown frequently for filter cleaning and there are set procedures to follow for this task. Shutdown will obviously be necessary if the unit is to be shipped to another contingency location or sent back to pre-positioning storage.

To shut the unit down for a short period (less than 24 hours) perform the following actions:

Set chemical feed RUN/PRIME valves to PRIME.

Set chemical feed pump control knobs to 10.

Turn REGULATE PRODUCT FLOW valve to full OPEN.

Set VENT PRODUCT WATER valve to open position.

Turn VENT VESSELS gate valve to full open position.

Set VENT CARTRIDGE FILTER valve to OPEN.

Set VENT PULSE DAMPENER valve to OPEN.

Set VENT MULTIMEDIA FILTER valve to OPEN.

Set R.O. PUMP switch to STOP.

Set BOOSTER PUMP switch to STOP.

Set CHEMICAL FEED PUMP switch to STOP.

Set RAW WATER PUMP #2 switch to STOP.

Set RAW WATER PUMP #1 switch to STOP.

Set circuit breakers CB-1 through CB-9 to off. If you are going to perform backwash actions, however, you will need to leave breakers CB-2, CB-8 and CB-9 on.

If shutdown is to last for an extended period (72 hours or more), additional efforts are required. First, you should perform the R.O. element cleaning and multimedia filter backwashing tasks described earlier. If the unit was purifying saltwater or brackish water, you will also need to flush the system. This is accomplished as follows:

Once backwashing is complete, drain the backwash tank. Place the product water discharge hose into the backwash tank.

Operate the ROWPU to produce nonchlorinated product water (at least 1000 gallons).

When the backwash tank is full or a minimum of 1000 gallons has been produced, shut down the ROWPU.

Remove the raw water strainer and suction hose from the raw water source and place it in the backwash tank of nonchlorinated water.

Start up the ROWPU and run it normally. Ensure, however, the chemical feed pump RUN/PRIME valves are in the PRIME position. You do not want chemicals injected into the system. Run at least 1000 gallons of the nonchlorinated water through the unit. Rinse down the unit and accessories with any remaining water. Fully shutdown the unit at this time.



RADIOLOGICAL/CHEMICAL OPERATIONS

ROWPUs come with deionization cartridges capable of removing radiological and chemical contaminants from source water. A biological cartridge is not required since the double barrier of membrane filters and chlorination is considered sufficient. Installation of the two cartridges, however, requires some changes in the configuration of the ROWPU/accessory set up. Both the raw water and product water systems are altered somewhat; the remainder of the ROWPU equipment package does not change. Operation of the system essentially does not change either. Because contamination is present, ROWPU operators must work in Nuclear, Biological and Chemical (NBC) protective ensembles. To set up the radiological/chemical capability, use the following procedures:

Raw Water System (figure 52)

Position ROWPU as close to the water source as possible—you are restricted to only one raw water pump under the radiological/chemical set up.

Connect 1 ½" x 25' discharge hoses between the RAW WATER coupling on the ROWPU panel and the discharge coupling of raw water pump #2. Use the minimum number of hoses to make this connection.

Connect three hard rubber suction hoses to the suction coupling of raw water pump #2

Connect the strainer to the end of the last suction hose.

Connect the float to the strainer with enough rope to let the strainer go under water but not rest on the bottom. Place the strainer and float in the water.

Connect raw water pump #2 electrical cable to RAW WATER PUMP #2 receptacle on the ROWPU junction box.

Figure 52. Raw Water System Layout for Radiological/Chemical Operations.

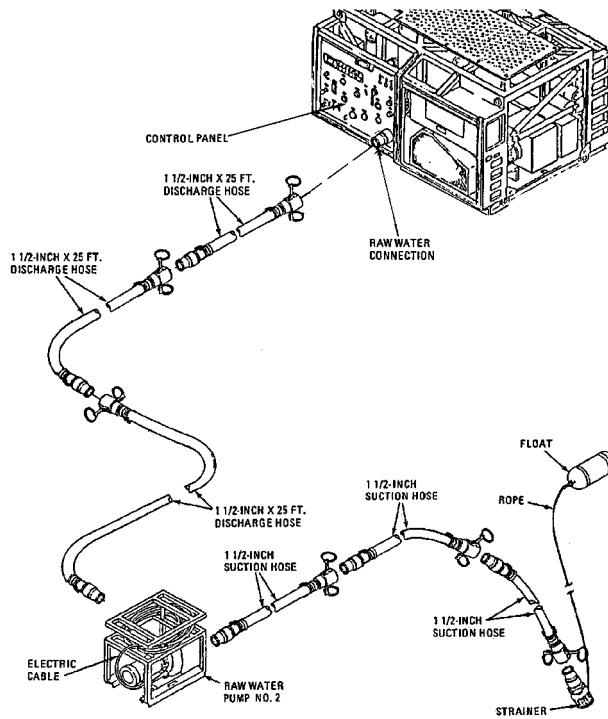

Assembling Deionization Cartridges (figure 53)

Both deionization cartridges are used in setting up the ROWPU for radiological/chemical operations. They are connected in series and inserted into the product water portion of the ROWPU system. Water must flow first through the cartridge labeled “FOR USE WITH CHEMICALLY CONTAMINATED WATER ONLY” and then through the cartridge marked “FOR USE WITH RADIOACTIVE CONTAMINATED WATER.” Assemble the cartridges as follows:

Figure 53. Deionization Cartridge Assembly.

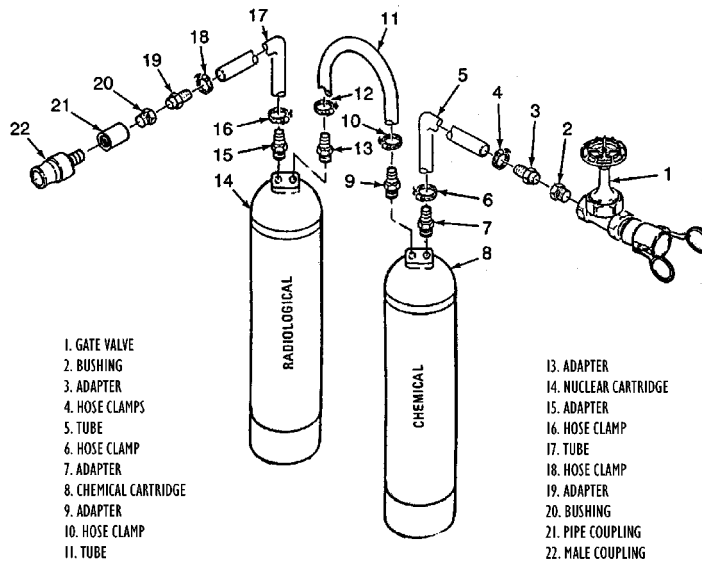

Apply antiseize tape to male threads of all threaded components.

Remove plugs from INLET and OUTLET ports on top of the chemical cartridge.

Install two adapters on chemical cartridge.

Remove plugs from INLET and OUTLET ports on top of radiological cartridge and install two adapters.

Remove male quick disconnect fitting from gate valve and connect bushing and barbed adapter.

Slide hose clamps over the end of a tubing section. Attach one end of the tubing to the barbed adapter on the gate valve with one of the clamps.

Using the second clamp attach the other end of the tubing to the INLET port on the chemical cartridge.

Connect a second tubing section with a clamp to the barbed adapter on the OUTLET port of the chemical cartridge.

Connect the other end of the second tubing section with a clamp to the barbed adapter on the INLET port of the radiological cartridge.

Connect a third piece of tubing with a clamp to the barbed adapter on the OUTLET port of the radiological cartridge.

Install male coupling and bushing on pipe coupling. Install a barbed adapter on the bushing.

Using a clamp attach the other end of the third tubing section to the barbed adapter on the coupling.

Product Water System. (figure 54)

Position and set up the two product water tanks

Figure 54. Product Water System for Radiological/Chemical Operations.

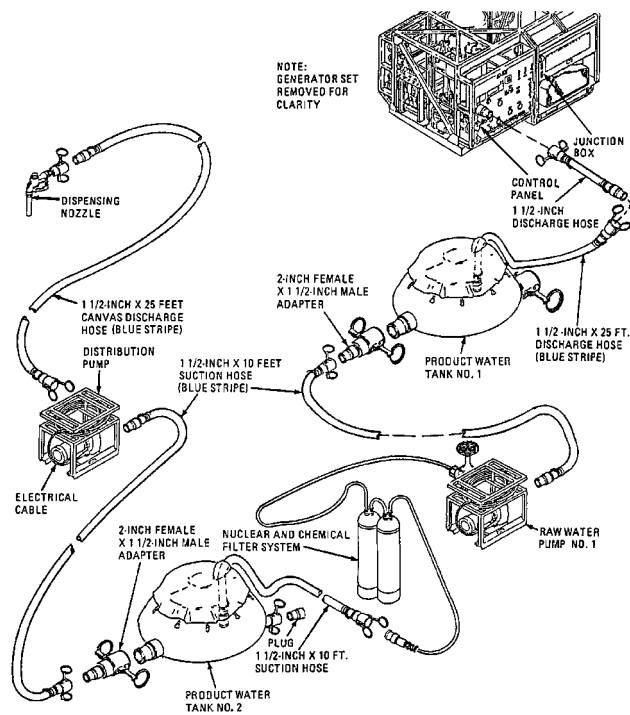

Install adapters (2" female x 1 1/2" male) on both tank's outlet couplings and plugs in both tank's inlet couplings.

Connect a canvas discharge hose to PRODUCT WATER coupling on ROWPU control panel. Place the end of the canvas hose in product water

tank #1. Ensure tank cover is secure. Remember to use only blue striped hose in the product water system.

Connect suction hose between adapter on outlet coupling of product water tank #1 and the suction coupling of raw water pump #1.

Connect gate valve on the radiological and chemical filter system to discharge coupling on raw water pump #1.

Connect discharge hose to male quick disconnect coupling on line leading from the nuclear and chemical filter system. Place other end of discharge hose in product water tank #2. Ensure tank cover is secure.

Connect suction hose between product water tank #2 outlet adapter and distribution pump suction coupling.

Connect discharge hose to discharge coupling on distribution pump. Connect other end of discharge hose to a dispensing nozzle or a storage bladder.

Connect distribution pump electrical cable to DISTRIBUTION PUMP receptacle on the ROWPU junction box. Connect raw water pump #1 electrical cable to RAW WATER PUMP #1 receptacle of the junction box.

Check security of all coupling connections.

Set CHLORINE RUN/PRIME valve to PRIME position.

Disconnect chemical feed hoses from CHLORINE chemical can. Remove lid from CHLORINE chemical can and insert chemical feed hoses into the top of can. Make sure suction hose is not submerged in the chlorine solution.

Chlorinate product water manually by adding appropriate quantities of chlorine solution to product water tank #2. Check with medical personnel for dosage rates.

With the exception of the CHLORINE chemical feed pump, operate the ROWPU using normal procedures.

After 100 hours of use, replace both deionization cartridges. Contact your environmental flight representatives on disposition of contaminated deionization cartridges at your location. Do not repackage contaminated cylinders with the ROWPU.



RECONSTITUTION

Once your deployment is completed it will be necessary to disassemble the ROWPU system and prepare it for shipment to another employment location or back to a pre-positioning site. Several steps are required to prepare the ROWPU for shipment; each must be followed religiously to ensure the unit will operate properly on its next deployment. Remember to clean each item as thoroughly as possible to preclude problems at Customs and prolong life of components. Reconstitution actions are as follows:

Shutdown the ROWPU.

Perform the extended shutdown procedures as explained earlier in the **SHUTDOWN** section.

Drain the ROWPU Pipes, Filters, and Connections.

Open the seven drain valves (figure 32).

Set front sample valves to open and rear sample valves to vent position (figures 34 and 35) to allow R.O. vessels to drain. When fully drained, close front sample valves and set rear sample valve to normal position

Drain Chemical Feed Pump.

Empty and rinse all utility pails. Fill one pail with water from the backwash tank and place it next to the chemical feed pump.

Place the full pail and one empty pail on top of the chemical feed cans.

Disconnect the four chemical feed suction hoses from the chemical cans and place the ends of the hoses in the full pail of water.

Disconnect the four chemical feed return hoses from the chemical cans and place the ends of these hoses in the empty pail.

Set CHEMICAL FEED PUMP switch on the control panel to START. Allow the pump to operate about 5 minutes until chemicals are rinsed from the chemical feed hoses, valves and pumps. Ensure all control knobs are set to 10.

Remove chemical feed suction hoses from the pail and allow chemical feed pump to run until water is pushed from the pump.

Set CHEMICAL FEED PUMP switch on the control panel to STOP.

Remove chemical feed return lines from the other pail and allow to drain.

Empty the chemical feed cans and rinse with brine water.

Install caps and plugs on chemical feed cans and chemical feed hoses.

Install tie strap over chemical cans.

Disassemble Product Water System.

Disconnect discharge hose from dispensing nozzle or storage bladders.

Open the gate valve between product water tank #1 and #2.

Set DISTRIBUTION PUMP switch on the control panel to START. Allow pump to operate until all water is drained from both product water tanks.

Set DISTRIBUTION PUMP switch to OFF. Set DISTRIBUTION PUMP circuit breaker CB-5 on the junction box to off.

Disconnect distribution pump electrical cable from DISTRIBUTION PUMP connector on the junction box. Install plug on end of electrical cable and cap on DISTRIBUTION PUMP connector. Roll the cable around the distribution pump frame.

Tip distribution pump on end and drain water from pump.

Disconnect gate valve, adapters, and all hoses; allow all items to drain and dry.

Install caps and plugs on hoses and roll them up.

Drain, dry and fold water tanks.

Disassemble Backwash Water System.

Remove hose from top of backwash tank.

Disconnect discharge hose from BACKWASH coupling on control panel. Place end of hose down stream.

Open gate valve at backwash tank.

Set the ELEMENT CLEANING switch to START and run the backwash pump until all water is drained from the brine tank. Once the tank is empty, set the ELEMENT CLEANING switch to OFF.

Set the BACKWASH circuit breaker CB-2 on the junction box to off.

Disconnect the backwash pump electrical cable from the BACKWASH PUMP connector on the junction box and roll the cable around the backwash pump frame.

Open the draincock on the bottom of the backwash pump and allow water to drain, then close the draincock.

Disconnect gate valve and all backwash hoses. Allow the items to drain and dry.

Install plugs and caps on all hoses and roll them up.

Disconnect strainer from backwash pump and secure it to the frame of the pump with the tie strap. Install the bolts that once held the strainer in place back on the pump frame.

Drain, dry and fold the water tank.

Disassemble Raw Water System.

Set RAW WATER PUMP #1 CB-3 circuit breaker and RAW WATER PUMP #2 CB-4 circuit breaker to off.

Disconnect RAW WATER PUMP #1 and #2 electrical cables from the junction box. Install caps on the electrical receptacles.

Install plugs on raw water pump electrical cables and wind cables around pump frames.

Open drain and vent valves on both raw water pumps. Allow water to drain, then close drain and vent valves.

Disconnect strainer and float from the suction hose and untie the float from the strainer.

Disconnect all hoses and allow to drain.

Install caps and plugs on hoses.

Roll up collapsible hoses.

Disassemble Waste Water System.

Disconnect canvas discharge hoses from WASTE and VENT VESSELS couplings on ROWPU control panel. Place caps on the couplings.

Allow hoses to drain, then install caps and plugs on hoses.

Roll up collapsible hoses.

Remove Total Dissolved Solids Monitor.

Disconnect TDS monitor power cable from TDS MONITOR POWER receptacle on the control panel. Install cap on the receptacle and plug in the power cable.

Disconnect sensor cable connector from the TDS MONITOR SENSOR receptacle. Install cap on the receptacle and plug in the sensor cable connector.

Remove TDS monitor from the control panel and stow it in the storage chest.

Drain Booster Pump.

Set BOOSTER PUMP switch to START. Allow pump to run for 5 seconds then set to STOP (do not operate switch more than 5 seconds at a time).

Repeat the previous step until no more water comes out of DRAIN #1 CARTRIDGE FILTER and DRAIN #2 CARTRIDGE FILTER (due to the location of the drains a second person will be required to watch the drain valves).

Disassemble and drain the pump itself.

Drain R.O. Pump.

After water stops flowing out of drain valves, push R.O. PUMP JOG switch on control panel to JOG. Hold it there for 3-5 seconds to force water from pump (do not operate switch more than 5 seconds at a time).

Repeat the previous step until no more water comes from the DRAIN PULSE DAMPENER drain (a second person will be required to watch the drain).

Shut Off Electrical Power.

Ensure all circuit breakers (CB-1 through CB-9) on the distribution panel are off.

De-energize the incoming power feed and disconnect power cables from the junction box receptacles J-1 and J-10. Install receptacle caps.

Remove Ground Rod.

Disconnect ground strap from ROWPU frame and ground rod.

Pull up ground rod and disassemble section by section.

Stow rods back on the control panel.

Remove Distribution Pump Quick Disconnect Fittings.

Remove 1 ½-inch male quick disconnect fitting from discharge coupling.

Remove 1 ½-inch female quick disconnect fitting from suction coupling.

Screw plugs into suction and discharge couplings.

Remove Backwash Pump Quick Disconnect Fittings.

Open draincock on the bottom of the backwash pump.

Remove 2-inch male quick disconnect fitting from suction coupling.

Remove 2-inch female quick disconnect fitting from backwash pump strainer.

Screw plugs into suction and discharge couplings.

Remove Raw Water Pump #2 Quick Disconnect Fittings.

Open drain and vent valves on raw water pump #2.

Remove 1 ½-inch female quick disconnect fittings from both suction and discharge couplings of pump.

Screw plugs into suction and discharge couplings.

Remove Raw Water Pump #1 Quick Disconnect and Strainer Fittings.

Open drain and vent valve.

Remove 1 ½-inch male quick disconnect fitting from strainer.

Remove 1 ½-inch male quick disconnect fitting from discharge coupling.

Remove 1 ½-inch female quick disconnect fitting from suction coupling.

Screw plugs into suction and discharge couplings on pump.

Remove Control Panel Quick Disconnect Fittings.

Remove 1 ½-inch male quick disconnect fittings from PRODUCT WATER, BRINE, and RAW water hose couplings on control panel.

Install caps on the above couplings.

Remove 2-inch male quick disconnect fittings from WASTE, VENT VESSELS, and BACKWASH water hose couplings on the control panel.

Install caps on the above couplings.

Stow Accessories.

Pack loose components in storage boxes. Refer to load plans on storage box lids for quantities and locations of items.

Bottom Layer (figure 55)

Stow raw water pumps #1 and #2 and secure to floor of ROWPU with tie down straps (two people required to lift pumps).

Stow backwash pump and secure to floor with tie down straps (four people required to lift pump).

Stow canvas hoses behind backwash pump.

Stow five utility pails between multimedia filter and pulse dampener.

Stow the float between backwash pump and canvas hoses.

Stow lug wrench, R.O. element tool, paddle and sledge hammer on the floor between the R.O. pump and backwash pump.

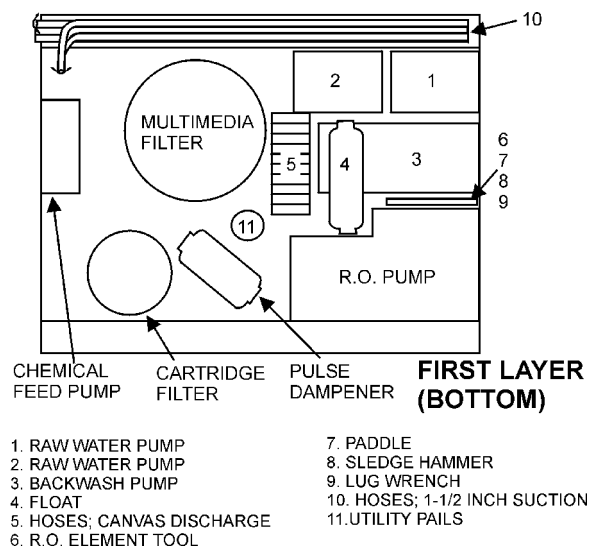
Figure 55. Stowage Plan, Bottom Layer.**Middle Layer (figure 56)**

Stow the three water tanks on end on top of R.O. pump and pulse dampener. Push the tanks as far back against the cartridge filter as possible.

Attach one end of three cargo straps to the frame of the ROWPU toward the rear of the unit. Pull the free ends of the straps to the front of the unit.

Place one of the storage chests on top of raw water pumps #1 and 2 and the second chest on top of the backwash pump. Pull both chests forward until even with the front of the ROWPU frame.

Fold the four canvas pump covers so they lay flat, then evenly spread them out on top of the storage chests.

Figure 56. Stowage Plan, Middle Layer.

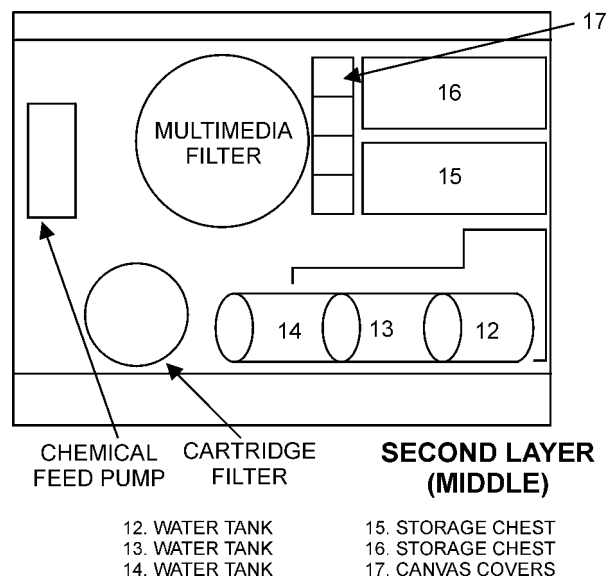

Top Layer (figure 57)

Secure both deionization cartridges together with hold down straps, then stow on top of canvas covers.

Stow one 1 ½-inch hard rubber hose and three 2-inch hard rubber hoses on top of the deionization cartridges.

Crisscross the cargo straps over all the accessories and attach free end to front of ROWPU frame. Operate ratchets until straps are tight.

Figure 57. Stowage Plan, Top Layer.

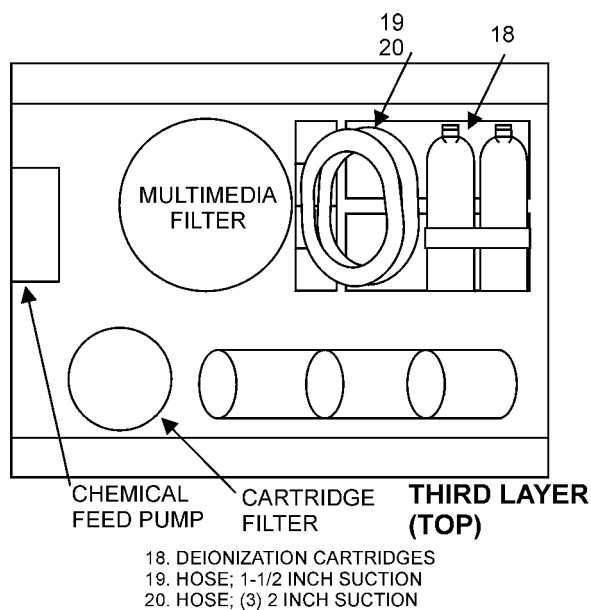

ROWPU Frame (figure 58)

Stow eight 1 ½-inch suction hoses in the ROWPU frame below the pressure vessel tubes. Position hose ends behind the chemical feed pump so that the hoses will not hang off the back of the ROWPU frame.

Secure hoses to ROWPU using hold down straps.

Figure 58. Hard Rubber Hose Stowage.



Install Cross Braces

Position top cross brace on ROWPU frame and pin into place.

Position bottom cross brace on ROWPU frame and pin into place.

Lower Canvas Cover

Lower all four sides of canvas cover. Fasten corner tie straps to secure all four panels.

Fasten tie straps along the bottom of the cover to the ROWPU frame.

Gather Other Associated Accessories

Collect other ROWPU components (distribution pump, chemical cans and rack, chemicals) not stowed on the ROWPU itself.

Clean/assemble components for shipment.

JOHN W. HANDY, Lt General, USAF
DCS/Installations & Logistics

