



NONRESIDENT TRAINING COURSE



Mineman, Volume 3

NAVEDTRA 14349

IMPORTANT

Any future change to this course can be found at
<https://www.advancement.cnet.navy.mil>, under Products.

You should routinely check this web site.

PREFACE

About this course:

This is a self-study course. By studying this course, you can improve your professional/military knowledge, as well as prepare for the Navywide advancement-in-rate examination. It contains subject matter about day-to-day occupational knowledge and skill requirements and includes text, tables, and illustrations to help you understand the information. An additional important feature of this course is its reference to useful information in other publications. The well-prepared Sailor will take the time to look up the additional information.

Training series information:

This is Volume 3 of a series. For a listing and description of the entire series, see NAVEDTRA 12061, *Catalog of Nonresident Training Courses*, at <https://www.advancement.cnet.navy.mil>.

History of the course:

- Sep 2003: Original edition released. Authored by MNCS(SW) James W. Tandy.

Published by
NAVAL EDUCATION AND TRAINING
PROFESSIONAL DEVELOPMENT
AND TECHNOLOGY CENTER
<https://www.cnet.navy.mil/netpdtc>

POINTS OF CONTACT	ADDRESS
<ul style="list-style-type: none">• E-mail: fleetservices@cnet.navy.mil• Phone: Toll free: (877) 264-8583 Comm: (850) 452-1511/1181/1859 DSN: 922-1511/1181/1859 FAX: (850) 452-1370	COMMANDING OFFICER NETPDTC N331 6490 SAUFLEY FIELD ROAD PENSACOLA FL 32559-5000
Technical content assistance. Contact a Subject Matter Expert at https://www.advancement.cnet.navy.mil/welcome.asp , under Exam Info, Contact Your Exam Writer.	

NAVSUP Logistics Tracking Number
0504-LP-102-3564

TABLE OF CONTENTS

CHAPTER	PAGE
1. Underwater Mine Maintenance System.....	1-1
2. Mine Handling and Storage	2-1
APPENDIX	
I. Glossary	AI-1
II. Abbreviations and Acronyms.....	AII-1
AIII. References Used to Develop This NRTC	AIII-1

ASSIGNMENT QUESTIONS follow Appendix III.

CHAPTER 1

UNDERWATER MINE MAINTENANCE SYSTEM

LEARNING OBJECTIVES

Upon completing this chapter, you should be able to do the following:

1. Identify the different levels of mine maintenance and maintenance schedules.
2. Describe the requirements for the recording and reporting of the maintenance on mines and associated equipment.
3. Recognize the types and causes of corrosion and the common types of materials available for use in corrosion prevention and protection against moisture.
4. Identify the proper shop procedures in torquing, power tool usage, maintenance of power tools, and mine assembly equipment.

The Underwater Mine Maintenance System is designed to ensure that all mine weapons systems are reliable and ready for issue. The system is used to prevent equipment failures that might otherwise result in repeated corrective maintenance actions.

As a Mineman, whether a supervisor or a worker assigned to the mine assembly division, you will encounter different levels of maintenance. This chapter defines each level as it applies to underwater mines and destructors and indicates the action assigned to each level. It also provides the rationale for the assignment of such actions.

Topics in this chapter include mine maintenance levels, recording and reporting maintenance, corrosion control, and shop procedures.

MINE MAINTENANCE LEVELS

The Underwater Mine Maintenance System is organized under the standard Department of Defense Maintenance System and contains three levels. All maintenance actions are to be performed under one of these levels.

Because of the many tasks associated with the corrective maintenance of mines and associated equipment, you should refer to *Underwater Mine Maintenance System*, NAVSEA SW550-FO-PMS-010; appropriate mine assembly manuals; and assembly-level items, class-B criteria manuals for additional information.

This section discusses organizational-level maintenance, depot-level maintenance, intermediate-level maintenance, programmed maintenance, and other maintenance cycles.

ORGANIZATIONAL-LEVEL MAINTENANCE

Organizational-level maintenance is the lowest level of maintenance. Performed by the user organization on its assigned equipment, it consists of inspecting, servicing, lubricating, adjusting, and replacing parts, minor assemblies, and subassemblies.

Once the weapons have been delivered to the planting vehicle and regardless of who performs the task, the following actions are organizational-level maintenance functions:

- Visual inspections
- Flight gear reorientation
- Safety device removal (safety pins, lanyards, etc.)

Mines in the custody of the user organizations are relatively maintenance free. Whether on board ships or stations for specific minefield planning missions or for contingency purposes, mines are off-loaded if the mission is aborted or if programmed maintenance is required. As an exception, actions to change a short-cycle maintenance period of a mine, in lieu of off-loading and performing programmed main-

tenance, are permitted when operational or tactical situations dictate. These actions must be approved by the operational commander according to chapter 3 of NAVSEA SW550-FO-PMS-010 and must be performed by Mobile Mine Assembly Unit (MOMAU) personnel.

The organizational-level function of delivering surface- or submarine-laid mines pierside for shipment in assembly configuration A is performed by shore-based activities. These mines normally do not require further assembly or maintenance, other than visual inspections, by personnel assigned to the user organization. The mines remain on board only for the duration of a specific mission and are returned ashore for programmed maintenance if the mission is aborted or canceled.

Aircraft-laid mines are delivered to air stations for planting by shore-based aircraft and are returned to an intermediate-level mine assembly activity if the mission is aborted. For planting by carrier-based aircraft, mines delivered on board may be accompanied by detachments of MOMAU teams. These teams, when required by operational commanders, are equipped to complete final preparations or make operational setting changes to the mines before their release to carrier personnel, who then load the mines on aircraft. Again, such consignments are normally for the duration of a specific mining mission only; the mines require no maintenance for that duration except visual inspection. The mines are returned to an intermediate-level maintenance site if the mission is aborted or when programmed maintenance is required.

DEPOT-LEVEL MAINTENANCE

Depot-level maintenance of mines includes the support of intermediate-level maintenance activities. Depots have more extensive industrial facilities and equipment than are available at intermediate-level activities.

Supported by technical repair standards (TRSs) and overhaul, screening, and repair specifications (OSRS) documents, the following actions are depot-level maintenance functions with regard to assembly-level items, test equipment, and support equipment: repair, alteration, modification, modernization, overhaul, reclamation, and reconstruction.

Depot-level maintenances are performed only at specific shore-based military or contracting facilities. Although depot-level maintenance, as applied to mine

weapons systems, consists of component maintenance, intermediate-level functions that are performed ashore may be performed at depots. When that is done, the functions remain intermediate-level functions; that is, intermediate-level maintenance on depot-stowed assembled mines may be performed at naval weapons stations.

A depot may have MOMAU teams assigned in support of operational requirements. In that case, intermediate-level mine maintenance remains intermediate, regardless of where it is performed.

INTERMEDIATE-LEVEL MAINTENANCE

Intermediate-level maintenance is performed by MOMAU activities responsible for providing direct- and general-support mine maintenance to user organizations. To the extent authorized by proper authority, the following actions are intermediate-level maintenance functions:

- Assembly, disassembly, maintenance, and testing of mines
- Testing replacement, adjustment, alteration and minor repair of assembly-level items
- Field calibration, adjustment, and repair of special-purpose test equipment and tools
- Preservation
- Inspection
- Emergency fabrication of nonavailable parts when so directed
- Provision of technical assistance to user organization

Although assembled mines are not repaired at any maintenance level, they are subject to intermediate-level programmed maintenance in which malfunctioning or worn assembly-level items may be adjusted, refurbished, or replaced by spares. In the course of such maintenance, piece parts that are subject to loss, damage, or wear may be replaced when they are listed in a mine bills of material (MBOMs) of an activity. Replacing such items is considered minor repair.

PROGRAMMED MAINTENANCE

Programmed maintenance is a systematic means by which mines are maintained in a ready-for-issue (RFI) status. This is accomplished by applying class-B

criteria, performing class-C testing, replacing malfunctioning components, performing visual inspections, and preventing the deteriorative effects of rust and corrosion.

Required readiness, and thus the maintenance effort, depends on the location of weapons and their intended uses. Maintenance functions must be planned and performed in such away to ensure a state of readiness that satisfies planned weapons usage.

This section describes how the Underwater Mine Maintenance System applies to service mines in various configurations and to mine assembly-level items and explains the maintenance program for such mines and items.

NOTE

Because programmed maintenance intervals change, refer to NAVSEA SW550-FO-PMS-010 for changes in maintenance intervals for mines, subassemblies, and assembly-level items.

Mines are stowed in one of six authorized degrees of assembly configurations: A, B, C, D, E, and F. These assembly configurations allow completely or partially assembled and tested mines to be assembled and/or issued to a mine-planting agent within the minimum amount of time specified by operational commanders. Operational commanders designate the configurations in which activities will maintain their mines, taking into consideration operational requirements, facilities, and personnel available at the activities.

To maintain mines in an RFI status, programmed maintenance must be performed. Programmed maintenance for mines is divided into two types (short cycle and long cycle) and consists of visual inspection, item replacement, component substitution, class-criteria, and/or class-C testing.

Short-Cycle Maintenance

Short-cycle maintenance must be performed periodically on mines stowed in assembly configurations A, B, and C to confirm their operability. Under certain conditions, short-cycle maintenance may be required more frequently than is specified in NAVSEA SW550-FO-PMS-010. Normally, a maintenance period is short-cycled because of battery-life limitations. Short-cycle maintenance is performed before the battery life expires of the mine.

Short-cycle maintenance should not be prolonged if the life of the battery has expired.

Mine assembly manuals outline short-cycle maintenance requirements and provide maintenance procedures for each specific mine. Generally, short-cycle maintenance consists of the following functions:

- Disassembly of the mine to the point where the instrument rack and the Safety Device and Arming Group (S&A) are removed and the electrical connections are accessible to perform the system tests.
- Performance of the instrument rack subassembly, the anchor, and the system (class-B) tests.
- Replacement of the defective assembly-level items.
- Subjection of the S&A group to class-B criteria.
- Removal of the tail section and the target detection device (TDD) subassembly from the mine case.
- Verification of the battery life of the mine and replacement of batteries that will not support another short-cycle maintenance period.
- Restoration of the mine case, the mechanism section, the anchor, the explosive section, the tail section, and the skids or crates.
- Performance of the instrument rack subassembly, the anchor subassembly, and the system tests, when appropriate, if any assembly-level items are replaced.
- Reassembly of the mine to its assigned assembly configuration.
- Performance of the assembled mine (class-C) tests.
- Submission of the appropriate maintenance reports.

Assembly-level items that are used as replacements during short-cycle maintenance must have a programmed maintenance schedule (PMS) date that is the same or later than the due date of the mine in which the items are being installed. The reason for this requirement is that the PMS date of the mine must be changed to that of the replacement item if an assembly-level item's PMS is due before the PMS (long-cycle) date of the mine.

When the urgency of the situation dictates, operational commanders may extend the short-cycle maintenance period for mines afloat. However, three factors must be considered in this extension:

1. The expected life of the mine
2. The resistor plug installed in the sterilizer
3. The storage time of the batteries

To calculate the extended stowage time for a mine, apply these factors to the following formula:

$$(X-Y) \div Z = \text{Extended stowage time } X= Y= Z=$$

<p>(X-Y)) Extended stowage time</p> <p>X = Expected life (in months) of the mine</p> <p>Y = Value (in months) of the resistor plug stalled in the mine</p> <p>Z = Effective stowage time of the mine batteries</p> <p>NOTE: If the result is less than 1, no extended time is allowed.</p>
--

Long-Cycle Maintenance

Long-cycle maintenance is performed to confirm the operability of designated assembly-level items installed in mines stowed in assembly configurations A, B, C, D, and E. This maintenance must be performed periodically according to table 3-2 of NAVSEA SW550-FO-PMS-010. These items are listed in *Mine Components, Description and Class-B Criteria*, NAVSEA SW550-AA-MMI-010.

Maintenance Extensions

A 10 percent random sample of explosive sections of Mine Mk 56 assembled to configurations D and E need only be subjected to class-B criteria every 6 years. However, if the 10 percent sample contains a reject, the lot from which the reject was taken must be subjected to 100 percent inspection. On the other hand, if all items in the sample meet the inspection criteria, the maintenance cycle can be extended for 6 additional years. These items are identified in the maintenance tables of NAVSEA SW550-AA-MMI-010.

Assembly-Level Items

An assembly-level item is a component that consists of one or more parts that are designed to function as an end item in a mine assembly.

Class-B criteria must be performed on assembly-level items. Visual inspections, parts inventories, and fictional tests are all considered class-B criteria. The required intervals for these criteria are detailed in NAVSEA SW550-FO-PMS-010. At such times, however, whether the job sheet for an assembly-level item contains only one, two, or all three of the criteria, it must be verified that such items meet the job sheet specifications if they are to be accepted into service use.

Two specific terms are applicable to the performance of these criteria:

- *Functional test:* The technician uses test instruments to verify specific operating characteristics.
- *Visual inspection:* Testing is performed by sight, feel, or manipulation, without the use of the test instruments.

According to the provisions of NAVSEA SW550-FO-PMS-010, assembly-level components are divided into four groups, commensurate with the maintenance necessary to ensure reliable operability. NAVSEA SW550-AA-MMI-010 provides a listing of all assembly-level components and assigns each to one of four groups, indicating the maintenance requirements for each.

Accordingly, an assembly-level component is assigned to a particular maintenance group based on the following factors:

- Design characteristics of the component
- Function of the component
- Shelf life of the material used in its manufacture
- Service history (as determined by fleet-originated data reports)
- Frequency of the programmed maintenance cycle of the weapon in which the component is used

Assembly-level items in the four maintenance groups designed or maintained as spares must receive the same maintenance as items in assembled mines. Maintenance of spares may be performed anytime

within the specified quarter at the discretion of the commanding officer or officer in charge.

Except in emergency situations as discussed in mine maintenance and assembly manuals, assembly-level items must be subjected to class-B criteria before they are installed in a mine. If a mine is upgraded for increased readiness or immediate planting, an assembly-level item that is within the long-cycle maintenance period may be installed in that mine without further tests. The maintenance cycle of the mine into which a tested spare has been installed does not change, and the spare component assumes the maintenance requirements of the mine.

Some assembled mines may need to be downgraded (converted to a lower configuration) or completely disassembled, and the assembly-level items repackaged and returned to stock. In either case, when such items are returned to stock, they receive maintenance according to the maintenance group into which they fall. Some assembly-level items (such as arming wires, preformed packings, flat gaskets, and soluble washers that have been used on a mine) must be discarded.

NOTE

Items, such as shorting clips, mine crates, and shipping containers, should be retained on board for use if the mine is downgraded.

After maintenance has been accomplished, the items are repackaged in their original packing, if available. If the original packing is not available, the items are repackaged according to with *Handling, Packing, Storing, and Transportation of Underwater Mines and Destructors for Shore-Based/Shipboard Operations*, NAVSEA SWO23-AB-WHS-010.

Table 1-1 categorizes the four maintenance groups and indicates the maintenance requirements for each.

Table 1-1.—Assembly-Level Item Maintenance Requirements

GROUP	MAINTENANCE REQUIREMENTS
1	Subject to class-B criteria at the time of long cycle maintenance
2	Subject to class-B criteria in conjunction with receipt inspection
3	Subject to class-B criteria before installation/issue
4	Subject to receipt inspection only, per NAVSUP P-805

MAINTENANCE REQUIREMENTS FOR GROUP 1 ITEMS.—As indicated in table 1-1, all assembly-level items in maintenance group 1 are subject to class-B criteria at long-cycle maintenance. It should be noted that many of these items listed in table 1-1 of NAVSEA SW550-F0-PMS-010 have had their long-cycle maintenance period extended to 6 years. Therefore, when IMAs are performing long-cycle maintenance, they should be aware that an extended maintenance period is appropriate to these items, but they should also be aware that a local record-keeping system is necessary to determine when the 6-year period expires.

MAINTENANCE REQUIREMENTS FOR GROUP 2 ITEMS.—Because of their inherent durability, group 2 items require no programmed or periodic maintenance, visual inspection, or piece-parts inventory following receipt. Upon receipt of group 2 items, a visual inspection and piece-parts inventory must also be performed within 12 months of receipt and may be repeated periodically thereafter at the option of local commands.

MAINTENANCE REQUIREMENTS FOR GROUP 3 ITEMS.—Group 3 items are subject to class-B criteria, as for group 1 items, but only at the time they are selected for installation in the weapon.

MAINTENANCE REQUIREMENTS FOR GROUP 4 ITEMS.—Items in group 4 need no maintenance whatsoever, except the receipt inspection requirements of NAVSUP P-805.

OTHER MAINTENANCE CYCLES

The maintenance of some mines and assembly-level items do not fall under the aforementioned maintenance levels and schedules. This section discusses Conversion Kit Mk 130.

Conversion Kit Mk 130

The Conversion Kit Mk 130 is used with Mines Mk 62 and Mk 63. These kits must be subjected to class-B criteria every 60 months. This includes class-B electrical test and visual inspection of TDD Mk 57 and class-B visual inspection of Booster Mk 59 and Arming Device Mk 32.

MAINTENANCE RECORDING AND REPORTING

All programmed mine maintenance actions, with the exceptions of the calibration and repair of test equipment and torque wrenches and the maintenance of containers and handling equipment, are required to be reported to and evaluated by the computerized Mine Warfare Data Base at the Naval Mine Warfare Engineering Activity (NAVMINEWARENGACT).

This information is also beneficial in making engineering changes in component design which, in turn, will give improved operational capability.

REPORTING FORMS

All phases of mine maintenance are covered by six report forms, five of which are supplements A, B, and E, to NAVSEA SW550-FO-PMS-010. The sixth form is the Metrology Equipment Recall and Report (METER) cards.

Instructions for using these supplements are detailed on the reverse side of each form. It should be noted that whenever the instructions on the forms are at variance with the instructions contained in NAVSEA SW550-FO-PMS-010, the instructions in the NAVSEA publication take precedence.

Supplement-A Report

Supplement A, Mine System OSR Data Report, as shown in figure 1-1, is used by depot-level activities to report technical repair standards (TRs), overhaul, screening, and repair (OSR) actions, ordnance-alteration (ORDALT) actions, and mine engineering field change (MEFC) actions that are performed by work directives.

NAVSEA SW550-FO-PMS-020 SUPPLEMENT A 15 MAY 1983 MINE - SYSTEM OSR DATA REPORT				TO: OFFICER IN CHARGE NAVAL MINE WARFARE ENGINEERING ACTIVITY YORKTOWN, VIRGINIA 23691				SHEET ___ OF ___			
SHORE ACTIVITY MAINTENANCE DATA COLLECTION SYSTEM USW UNDERWATER MINES NAVSEA 4790/5 (5A) REPORT SYMBOL: 4790/5 (5A)				FROM (activity)		PERFORMING TECHNICIAN/SUPERVISOR		RATE			
				COMMAND APPROVAL (signature)							
COMPONENT INFORMATION SECTION											
REPORTING ACTIVITY	REPORT SERIAL	REPORT DATE				COMPONENT NAME	MK	MOD	MMC/EIC	M D	TEST REFERENCE
		M	M	D	D						
PASSED ONLY - LOTS											
LOT NO.	QUANTITY	LOT NO.	QUANTITY	LOT NO.	QUANTITY	LOT NO.	QUANTITY				
PASSED ONLY - SERIAL NUMBERS. (ONE SERIAL NO. PER BLOCK)											

Figure 1-1.—Supplement A, Mine System OSR Data Report.

MN2f01001

Supplement-B Report

Supplement B, Mine System Class-B Data Report, as shown in figure 1-2, is used to report results of intermediate-level tests and inspections of assembly-level mine items and subassemblies.

Specifically, this form is used to report the following items:

- Results of class-B criteria applied to assembly-level items at long-cycle maintenance, but only on those items designated as requiring the use of the supplement-B form in NAVSEA SW550-AA-MMI-010.
- Results of class-B criteria applied to assembly-level items before installation/issue, but only on those items designated as requiring the use of the supplement-B form in NAVSEA SW550-AA-MMI-010.
- Damage to explosive items as a result of handling while in stowage. An accident investigation report, as prescribed in *Mishap*

Investigation and Reporting, OPNAVINST 5102.1, is also required.

For further instructions on the preparation of supplement-B data reports, refer to NAVSEA SW550-FO-PMS-010.

Supplement-E Report

Supplement E, Mine System Support-Material Data Report, as shown in figure 1-3, is used to report intermediate-level maintenance actions that are not covered by supplement B. Supplement E provides a means for reporting only deficiencies (problems, errors, failures, etc.) and, as such, requires that the deficiencies be expressed verbally, not numerically.

Specifically, this form is used to report the following items:

- Results of class-B criteria applied to assembly-level items that were rejected at long-cycle maintenance and that are not reportable on supplement B.

SW550-FO-040 SUPPLEMENT B 15 MAY 1983		SHEET _____ OF _____		FOR NAVMINWARENGACT USE ONLY	
MINE SYSTEM CLASS B DATA REPORT					
TO: OFFICER-IN-CHARGE NAVAL MINE WARFARE ENGINEERING ACTIVITY YORKTOWN, VIRGINIA 23691		FROM: ACTIVITY _____			
PERFORMING TECHNICIAN (PRINT)	RATE	QA INSPECTOR (SIGNATURE)	COMMAND APPROVAL (SIGNATURE)		
1. REPORTING ACTIVITY _____		2. REPORT DATE NO. _____		3. REPORT DATE _____	
4. PUBLICATION NUMBER _____		5. VOLUME _____		6. PART _____	
				7. REVISION _____	
				8. CHANGE _____	
9. JOB SHEET NO. _____		10. FUNCTION CODE FC 04 REMARKS _____		11. MMC NO. _____	
				12. BATTERY CODE <u> </u> / <u> </u> / <u> </u> MO YR MO/10	
13. ITEM NAME _____		14. MK _____		15. MOD _____	
16. QUANTITY PASSED _____		17. QUANTITY PASSED AFTER ADJUSTMENT _____		18. QUANTITY PASSED AFTER REPAIR ¹ _____	
				19. QUANTITY FAILED/ _____	
20. TOTAL QUANTITY TESTED FOR THIS REPORT _____		21. SUBASSEMBLY TEST REPORT SERIAL NUMBER ² _____			
<p>¹ To report quantity "failed" or "passed after repair" use Supplement B continuation sheet. DO NOT INCLUDE ITEMS IN "QUANTITY PASSED OR "QUANTITY PASSED AFTER ADJUSTMENT" ON CONTINUATION SHEET.</p> <p>² Enter subassembly test report serial number in item 21 when reporting test results of components suspected of causing subassembly to fail.</p>					
MN2f01002					

Figure 1-2.—Supplement B, Mine System Class-B Data Report.

NAVSEA SW550-FO-PMS-060 SUPPLEMENT E 15 APRIL 1987 MINE-SYSTEM SUPPORT-MATERIAL DATA REPORT				SECURITY CLASSIFICATION (STAMP RED)		SHEET ____ OF ____	
TO: OFFICER-IN-CHARGE NAVAL MINE WARFARE ENGINEERING ACTIVITY YORKTOWN, VIRGINIA 23691			FROM (ACTIVITY)		PERFORMING TECHNICIAN (PRINT)		RATE
							COMMAND APPROVAL (SIGNATURE)
SECTION 1: CARD IDENTIFICATION							
1. REPORTING ACTIVITY		2. REPORT SERIAL		3. REPORT DATE MO DA YR		4. WEAPON SYSTEM REFERENCE MK MOD OA MMC	
						5. PROB CODE	
						6. service	
SECTION 2: PROBLEM IDENTIFICATION							
1. HARDWARE IDENT - NAME		2. MK	3. MOD	4. MMC	5. SERIAL		6. LOT/CONTACT
8. SOFTWARE IDENT - PUB		9. VOL	10. PART	11. REV	12. CHG	13. PAGE	14. PARA
						15. STEP	16. OTHER
17. NARRATIVE DESCRIPTION							
18. ACTION TAKEN LOCALLY . . . RESULT		FOR NAVMINWARENGACT USE ONLY					
		ROUTING			ACTION		
					RESPONSE REQUIRED		
					NO RESPONSE REQUIRED		
					REQUIRES IDP, ADP, PUB, PCD, ACTION		
					FOR INFO/RETAIN		
					HARDWARE FAILURE CODE		
					HARDWARE DESTINATION CODE		
					OTHER:		

MN2F01003

Figure 1-3.—Supplement E, Mine System Support-Material Data Report.

- Results of class-B criteria applied to assembly-level items that failed class-B criteria before installation/issue and which are not reportable on supplement B.
- Problems dealing with improper packaging nomenclature and labeling.
- Damage to handling equipment, tools, and facilities.
- Safety problems, logistical problems, and other problems not covered by supplement B.

Message Format for Supplements B and E

A message is used in lieu of supplements B and E data reports to report critical defects and failures in mine components that require an immediate response from the NAVMINWARENGACT to resolve the situation. Example: A message report would be required if the failure rate of a component exceeded the 25 percent rejection rate of a maintenance lot. For

further information and guidance, refer to NAVSEA SW550-FO-PMS-010.

MASTER RECORD SHEET

The master record sheet (MRS) is officially designated as the Assembly/Maintenance Master Record. It is covered by six forms: supplements G, H, K, L, M, and N of NAVSEA SW550-FO-PMS-010.

These supplements are used by mine-assembly personnel to provide assembly and maintenance data on a mine and to provide the operational settings relative to that mine. These supplements are shown in figures 1-4 through 1-7.

When mines are upgraded to configuration A, B, or C, an MRS (original and duplicate) is prepared and filed locally until the mine is either planted or downgraded to configuration E. At that time, the MRS is destroyed since MRSs are only required on mines in configurations A, B, and C.

UIC: _____ LOT NO: _____

SW550-FO-PMS-080 SUPPLEMENT G 01 FEB 1990
 ASSEMBLY/MAINTENANCE MASTER RECORD
 FOR MINES MK 52/55 MODS 2, 3,, 12, 13, AND MINES MK 56

MINE SETTING CODE (FROM MINE SETTING SHEET FOLDER)

MINE NUMBER	MK/MOD	QA	STERILIZE OR S D	DA/DR (DAYS, HRS, MIN)	SHIP COUNT	LP	ICDP	IN-OUT	SENS		SENS	ILD			NOTE	FIELD NO.	CHANGE	OPTIONAL
1	3	4	5	6	7	8	9	10	11-M	11	11-P	12	13	14	15	16	17	18

(All actions performed IAW applicable pubs)

ITEM	SERIAL NUMBER	MK	MOD	QA	WEAPON CONFIG	LONG CYCLE	SHORT CYCLE	ACTION	DATE	SUPERVISOR	INSPECTOR

Explosive Devices Serial/Lot Numbers

BATTERY MK _____ EFFECTIVE LIFE* _____ MONTHS AS OF _____ (DATE)
 BATTERY MK _____ EFFECTIVE LIFE* _____ MONTHS AS OF _____ (DATE)
 BATTERY MK _____ EFFECTIVE LIFE* _____ MONTHS AS OF _____ (DATE)
 BATTERY MK _____ EFFECTIVE LIFE* _____ MONTHS AS OF _____ (DATE)
 BSTR MK _____ MOD _____ PROPELLANT ASSY _____

*Remaining useful storage life at expected storage temperature

SEE REVERSE SIDE FOR INSTRUCTIONS

CONFIDENTIAL (When Mine Setting Code strip is attached)

Classified by: _____
Review on: _____

MN2f01004

Figure 1-4.—Supplement G, Master Record for Mine MK 56.

If the mine is placed on board an aircraft carrier, a copy of the MRS accompanies the mine. If the mine is planted, duplicate copies of all MRSs are retained for reference and originals are forwarded to the Commander, Mine Warfare Command (COMINEWARCOM).

Any mine operational setting changes, made after the initial assembly, must be recorded on the master record sheet.

CORROSION CONTROL

To perform mine maintenance properly, you must be familiar with the types and causes of corrosion and the common types of materials available for use in corrosion prevention and in protection against moisture. You must know what materials to use for

cleaning and removing corrosion from the equipment and how to use the cleaning materials properly. You must also understand the procedures for, and know the equipment used in, applying preservatives.

Metal corrosion is the deterioration of metal as it combines with oxygen to form metallic oxides. The most significant corrosion element is oxygen. Oxidation, the combining of wood or metal with oxygen, is the process that causes wood to rot or burn and metal to corrode.

Corrosion is caused by either electrochemical or direct chemical reaction of metal with an oxidizing agent. The most familiar process of corrosion is a reaction between metal and moisture and is electrochemical in nature. In the direct chemical

UIC: _____ LOT NO: _____

SW550-FO-PMS-090 SUPPLEMENT H 01 FEB 1990
 ASSEMBLY/MAINTENANCE MASTER RECORD
 FOR MINES MK 62,63, 64 AND 65 MOD 0

MINE SETTING CODE (FROM MINE SETTING SHEET FOLDER)

MINE NO.	MK/ MOD	OA	PRESET PROGRAMMER SETTINGS												NOTE	FIELD NO.	OPTIONAL	MK 65 ONLY HI-LO ALTITUDE
			SELECTORS				SWITCHES				INDICATORS							
			1	2	3	4	1	2	3	4	1	2	3	4				
1	2	3	4	5	6	7	8	9	10	11	12	13	14	15	16	17	18	19

(All actions performed IAW applicable pubs)

ITEM	XPL LOT/ SERIAL NUMBER	MK	MOD	OA	WEAPON CONFIG	LONG CYCLE	SHORT CYCLE	ACTION	DATE	SUPERVISOR	INSPECTOR
Case/Bomb											
Tail Section		7									
Delay Element		21									
Safety Dvc Arming Gp		45									
Target Detecting Device		57									
Arming Device											
Adapter		123									
Battery		132									
Booster		59									

BATTERY MK 131 MOD _____ LOT/SER NO. _____
 BTRY ACTIVATED DATE _____

SEE REVERSE SIDE FOR INSTRUCTIONS

CONFIDENTIAL (When Mine Setting Code strip is attached)

Classified by: _____
Review on: _____

MN2f01005

Figure 1-5.—Supplement H, Master Record for Mines Mk 62, 63, 64, and 65 Mod 0.

attack, the reaction is similar to that which occurs when acid is applied to bare metal.

Corrosion is more serious under wet and humid conditions than it is under dry conditions. Salt in the air also promotes corrosion. Factors that influence corrosion to a lesser or greater degree include types of metal, grain direction of metal, manufacturing and operational stress, contact by dissimilar metals, and environment. Of these factors, the environment is the major one. Moisture and salt are the two most common elements of the environment that influence corrosion.

Corrosion control depends on a separation between the metal or wood and the environment. The separation is accomplished in different ways. On mines, a good coat of paint provides most of the corrosion protection. However, grease and other lubricants are used at seams to prevent entry of moisture, and preservatives are used on unpainted

surfaces. Tarpaulins, covers, and caps provide some, but not 100 percent, protection. Although paint is a preservative and provides excellent protection, it is subject to oxidation and decay through weathering. Lubricants are eroded by water and moisture, and preservatives offer only temporary protection.

An important part of mine warfare is the maintenance of the stowed weapons in an RFI status. This is the reason mines and associated equipment are maintenance on a regular basis, as discussed earlier in this chapter. Corrosion control is an important part of this maintenance.

This section discusses the common materials used in the construction of mines (such as steel, aluminum, stainless steel, and thermal-coated surfaces) and the characteristics of corrosive products that can develop on these materials.

UIC: _____ LOT NO: _____

SW550-FO-PMS-110 SUPPLEMENT K 01 FEB 1990
 ASSEMBLY/MAINTENANCE MASTER RECORD
 FOR MINES MK 67

MINE SETTING CODE (FROM MINE SETTING SHEET FOLDER)

CASE NUMBER	MK/MOD	OA	TABS CUT ON FIRING MECHANISM AND ADAPTER	DIVE	ENABLE (YDS)	DEPTH (FT)	GYRO ANGLE (DEGREES)	NOTE	FIELD NO.	CHANGE	OPTIONAL

(All actions performed IAW applicable pubs)

ITEM	XPL LOT/SERIAL NUMBER	MK	MOD	OA	WEAPON CONFIG	LONG CYCLE	SHORT CYCLE	ACTION	DATE	SUPERVISOR	INSPECTOR
Mine Main Assembly		4									
Adapter		141									
Firing Mech or TDD											
Battery		132									
Exploder		19									
Arming Device		2									
Explosive Section		13									
Battery		46									
Adapter		136									

BATTERY MK 131 MOD _____ LOT/SER NO. _____
 BTRY ACTIVATED DATE _____

SEE REVERSE SIDE FOR INSTRUCTIONS

CONFIDENTIAL (When Mine Setting Code strip is attached)

Classified by: _____
Review on: _____

MN2f01006

Figure 1-6.—Supplement K, Master Record for Mine Mk 67.

STEEL SURFACES

Steel is used in the manufacturing of Mine Cases Mk 65, 64, 63, and 62; as well as the Mk 56's anchor. Steel is susceptible to a well-known and easily recognized form of metal corrosion—the familiar reddish-colored rust. When steel starts to corrode, dark iron oxide usually forms first. This iron oxide may act to protect the steel surface; however, if sufficient oxygen and moisture are present, the oxide converts to hydrate ferric oxide—common red rust.

The procedure to remove corrosion from the steel surfaces of mines depends on the protective coating on the surfaces. Minor corrosion scratches or burrs may be removed from surfaces with no protective coating, such as flanges at watertight openings, by hand polishing with abrasive cloth or copper wool. These flanged surfaces are then cleaned with a cleaning compound solvent and protected with a thin coat of grease. With respect to flanges on tail covers,

arming-device well covers, and blanking plates, corrosion may be removed by using a glass bead blaster.

Steel surfaces that have a plating material are subject to corrosion in the form of a white powder. This white powder may be removed by using a cloth dampened with fresh water. A plated surface with discoloration requires no treatment for corrosion, because the plating is still offering sacrificial protection for the base metal. Corrosion of the base metal, commonly referred to as rust, will occur after the plating is destroyed. Rust from plated surfaces may be removed by using copper wool. Flange surfaces at watertight openings that have had corrosion removed must be protected with a thin coat of grease and other areas where base metal is exposed must be protected with primer.

Painted steel surfaces with chipped, loose, blistered, or cracked paint or corrosion of the base

UIC: _____ LOT NO: _____

SW550-FO-PMS-130 SUPPLEMENT M 01 FEB 1990
 ASSEMBLY/MAINTENANCE MASTER RECORD
 FOR MINE MK 65 MOD 1

MINE SETTING CODE (FROM MINE SETTING SHEET FOLDER)

CASE (MINE) NO.	MK/ MOD	OA	PRESET PROGRAMMER SETTINGS										NOTE	FIELD NO.	OPTIONAL
			1	2	3	4	5	6	7	8	9	10			
1	2	3	4	5	6	7	8	9	10	11	12	13	14	15	16

(All actions performed IAW applicable pubs)

ITEM	XPL LOT/ SERIAL NUMBER	MK	MOD	OA	WEAPON CONFIG	LONG CYCLE	SHORT CYCLE	ACTION	DATE	SUPERVISOR	INSPECTOR
Case		65									
Tail Section		7									
Delay Element		21									
Safety Dvc Arming Gp		45									
Target Detecting Device		58									
Arming Device		2									
Battery		132									

BATTERY MK 131 MOD _____ LOT/SER NO. _____
 BTRY ACTIVATED DATE _____

SEE REVERSE SIDE FOR INSTRUCTIONS

CONFIDENTIAL (When Mine Setting Code strip is attached)

Classified by: _____
 Review on: _____

MN2f01007

Figure 1-7.—Supplement M, Master Record for Mine Mk 65 Mod 1.

metal of all assembly-level items can be repaired by using wire brushes, abrasive cloths, or power tools. When you use power tools or wire brushes on explosive-loaded mine cases, try to avoid creating dangerous hot spots.

When the surface condition of a mine case is poor, you may need to remove paint and corrosion by sandblasting. When sandblasting a mine case, take the following precautions:

1. Ensure that the mine case is securely connected to an earth ground.
2. Allow only experienced operators to sandblast explosive-loaded mine cases.
3. Wear personal protective equipment. Include a supplied-air sandblasting hood, as shown in figure 1-8, and hearing and hand protection.
4. Use caution to avoid overheating of the case or reducing the thickness of the case excessively.
5. Close all openings on the mine case with blanking plates or covers, install extra nuts and

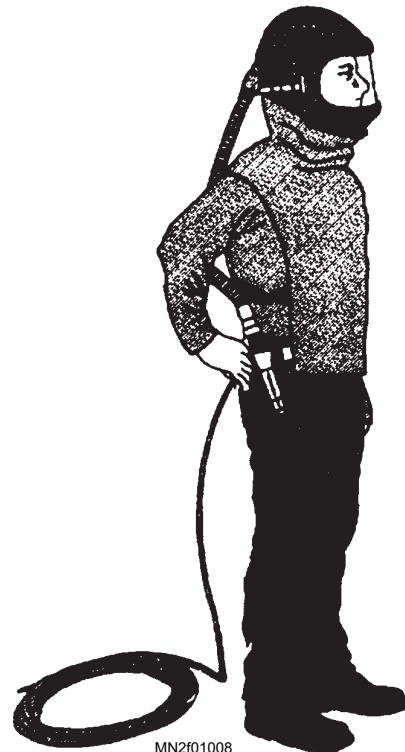

MN2f01008

Figure 1-8.—Abrasive sandblasting hood.

screws to cover all exposed threads, remove suspension lugs, and fill lug holes with rags.

6. Use only sand or black grit (mineral grit) of 40 to 80 mesh.
7. Use an abrasive only once.
8. Do NOT sandblast in the immediate area of the filling hole cover.
9. Do NOT sandblast flange or sealing areas.

ALUMINUM SURFACES

Aluminum, in its pure state, is very resistant to corrosion, but it is too soft and weak for most applications. Therefore, aluminum alloys are used in the manufacture of the Mine Mk 67, as well as some mine components, such as actuation counters, clock delays, and flight gear. These are all subject to corrosive attacks.

Corrosion is most severe when moisture is present or when the aluminum is in contact with another type of metal or with another type of aluminum alloy. The first indication of corrosion is the appearance of white powdery residue in the area of contact. Later, pitting and scoring of the aluminum surface are evident. Finally, the aluminum deteriorates completely.

Use an abrasive cloth to remove corrosion from a painted aluminum surface. Then clean the surface with a cleaning compound solvent, prime with zinc chromate, and repaint with applicable paints as listed in chapter 2 of NAVSEA SW550-AA-MMI-010.

STAINLESS STEEL SURFACES

Stainless steel is an alloy of steel and chromium. The chromium helps to prevent corrosion. Stainless steel is used in manufacturing the Mine Mk 56 and its Mk 2 instrument rack. The surface of the metal has a tendency to pit when it is exposed to a marine environment. Corrosion on stainless steel is indicated by either a rough surface or a red, brown, or black stain.

Use an abrasive cloth or a power tool to remove corrosion from stainless steel. After you remove the corrosion, you may need to apply a primer. This can be done in the following two steps:

1. Apply a solution of phosphoric acid and resin. (This application coats the surface with a plastic film that improves the adhesiveness of subsequent primer coats.)

2. Apply a coat of vinyl to protect the first primer coat as soon as practicable.

CAUTION

Phosphoric acid is highly corrosive. Wear goggles, a rubber apron, and chemical-resistant rubber gloves when handling acid. Read the material safety data sheet (MSDS), available from your supervisor, before handling or using phosphoric acid.

EXTERNAL THERMAL-COATED SURFACES

Bombs missing more than 7 square inches of thermal coating are not considered to be thermally protected and, therefore, are restricted from issue to aircraft carriers. Bombs missing less than 7 square inches can be repaired by using a putty knife or a cold chisel and a hammer to remove any unbonded coating from the bomb body.

Particular attention should be given to the forward end. If the coating is unbonded, it comes off in chunks. If the coating is bonded, it comes off in small chips and a residue is left on the bomb. Remove the coating in all directions from the unbonded coating until the bonded coating is reached. Bombs with minor chips, cracks, and so forth, that are not rejected must have areas where the coating is missing touched up with primer.

On the Mk 65 mine, the thermal coat is epoxy-based with asbestos or ceramic fibers. Do not sand or make dust. The surface can be cut or shaped with a knife to define the repair area. Remove the minimum possible amount of material. Wear safety-approved organic vapor respirators, goggles, and gloves when using solvents or paint or when applying a thermal coat. Repair the mine according to the instructions in NAVSEA SW550-AA-MMI-010.

PAINTING OF MINES

Painting is the process of applying coats of paint to surfaces, primarily for the preservation of the surfaces. It seals the pores of wood and steel, arrests decay, and helps prevent the formation of rust and other types of corrosion.

Basically, a paint job consists of one primer coat and one or more finish coats. The primer coat is the first coat applied to a properly prepared and cleaned surface. It improves the adhesiveness of the outer, or

finish, coat or coats of paint and provides protection to the surface against corrosion. For color-coding general stenciling and more extensive repainting, refer to chapter 2 of NAVSEA SW550-AA-MMI-010.

The most common primer used in the Mine Force is zinc chromate. But zinc chromate paint dust is toxic; therefore, a respirator must be used during painting, sanding, and wire brushing operations. After the primer coat or coats are dry, one or more finish coats are applied.

CAUTION

All paints and thinners are hazardous materials. Most of these materials are flammable or combustible and can be hazardous to worker health. Avoid prolonged skin contact with paints and thinners and wear approved respirator protection. Read the MSDS, available from your supervisor, for the specific hazardous materials before you handle or use them.

SHOP PROCEDURES

Specific shop procedures are approved for use with explosive-loaded components during the maintenance and assembly of mines and mine components. These procedures must be followed to prevent personal injury or damage to equipment and possible explosion.

This section discusses tools, painting equipment, and battery storage.

TOOLS

Tools used in Mine Force shop procedures include torque wrenches and power tools. These tools are discussed in the following subsections.

Torque Wrenches

Torque wrenches maybe either manual or pneumatic. NAVSEA SW550-AA-MMI-010 gives additional instructions in using torque wrenches.

MANUAL TORQUE WRENCHES.—Torques are generally specified in a single value, such as 18 pound-feet or 12 pound-inches. In such cases, torque tolerances are as follows:

- From 2 to 10, a tolerance of plus or minus 1 is allowed.

- From 11 to 30, a tolerance of plus or minus 2 is allowed.
- Above 30, a tolerance of plus or minus 5 is allowed.

Therefore, for a specified torque of 9 pound-inches, any applied torque between 8 and 10 pound-inches is acceptable. Torques specified in mine assembly procedures can be converted to or from pound-inches or pound-feet, as necessary, to accommodate the increment graduations of the torque wrench. This can be accomplished by multiplying pound-feet by 12 or by dividing pound-inches by 12, as appropriate.

When assembly instructions state to tighten mount, or secure an object (rather than giving a specific torque), fasteners must be tightened with the appropriate tool without the use of excessive pressure. Items, specified to be secured hand-tight, must never have tool pressure applied.

Reliability of a torque wrench can be improved before use by exercising the wrench a minimum of eight times at 60 percent of the rated torque range. This is accomplished by engaging the wrench with a test fastener and by applying the necessary pressure on the handle until the audible torque-indicating mechanism is activated.

Never attempt to apply a permanent torque value to a wrench by means of spot welding the micrometer at a given setting. That only damages the wrench and reduces the reliability of the instrument.

PNEUMATIC TORQUE WRENCHES.—

Pneumatic torque wrenches are adjustable power torque tools that require a working pressure of 90 pounds per square inch (psi) at the tool. When in proper calibration, pneumatic torque wrenches are authorized for both rundown and application of final torque to any fastener. Final torque, as used here, is the value specified in mine assembly and maintenance documents.

For the proper use of a pneumatic torque wrench, it must be connected to an air supply containing a moisture separator, an air-pressure regulator, and a means of introducing lubrication oil into the wrench. Accordingly, the torque wrench must be connected to the simple system shown in figure 1-9 or to the spiral flex system shown in figure 1-10.

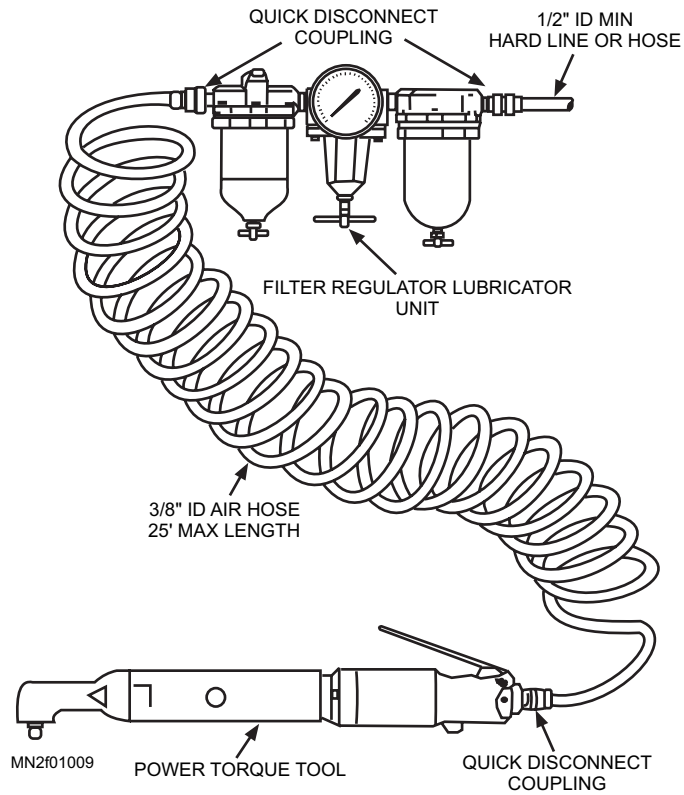

Figure 1-9.—Simple air distribution hookup.

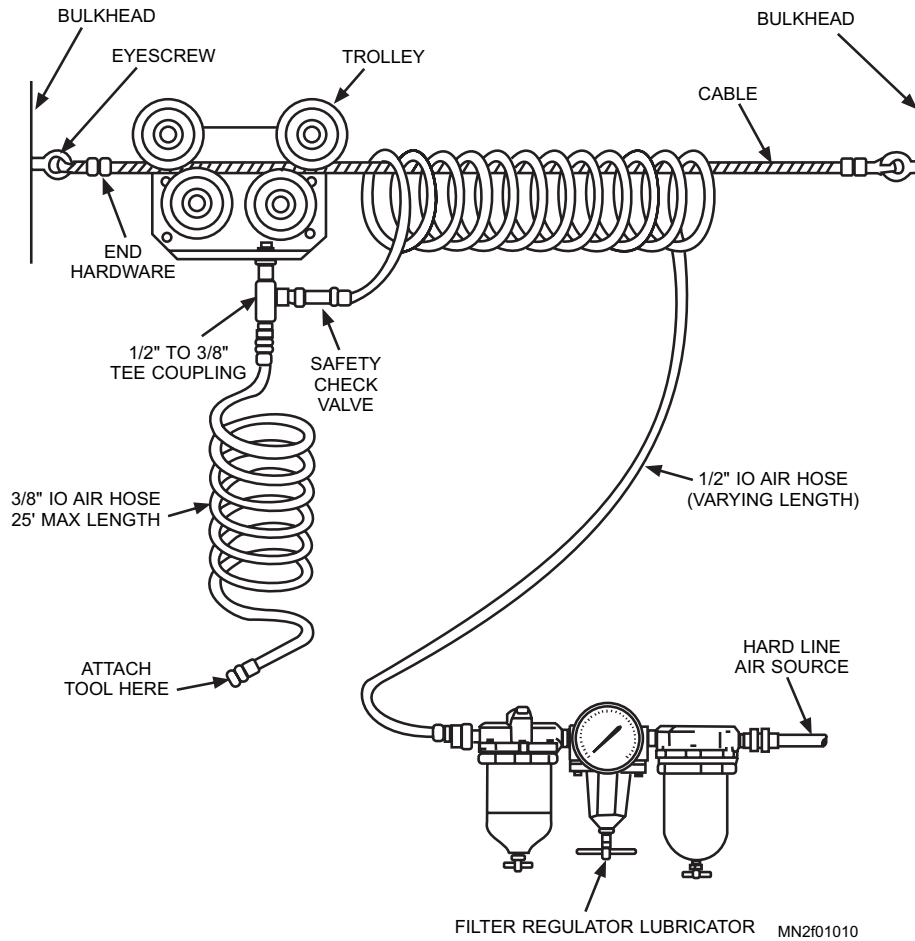

Figure 1-10.—Spiral flex system hookup.

Power Tools

Power tools are so common in the Navy that personnel in all ratings use some type of power tool at one time or another. The Mine Force uses both electric and air-driven pneumatic power tools and equipment.

Safe practices in the use of power tools cannot be overemphasized. The following general safety measures must be observed when operating or maintaining power tools:

- NEVER operate a power tool unless you are thoroughly familiar with its controls and operating procedures.
- ALWAYS inspect all power tools before use to ensure that they are clean and in the proper state of repair.
- ALWAYS ensure that the switch on the tool is in the OFF position before connecting the power tool to a power source (electricity, air, etc.).
- ALWAYS give the power tool your FULL and UNDIVIDED attention when you are operating it.
- ALWAYS keep all safety shields in position. Wear hearing protection and safety glasses or goggles.
- ALWAYS ensure that the work area has ample lighting.
- ALWAYS fasten loose-fitting clothes or, better yet, do NOT wear such clothing. Wear snug-fitting clothes.
- ALWAYS remove the power source before cleaning or working on jammed machinery.
- ALWAYS connect the electrical power tool to the extension cord before connecting the extension cord into the outlet, if an extension cord is used. Always unplug the extension cord from the outlet before disconnecting the power tool from the extension cord. (The extension cord and the power tool cord combined must not be longer than 25 feet each, or 50 feet in total footage.)

ELECTRIC POWER TOOLS.—Electric power tools are authorized provided that no electro-explosive devices (EEDs) are installed. Some of the most common electric power tools used in the Mine Force include drills, saws, and sanders.

The most frequently used electric power tool in the Mine Force is the drill. Although it is especially designed for drilling holes, it can be used for paint mixing and wire brushing when accessories are added. A portable electric drill is classified by size according to the maximum size of the straight shank drill it will hold. For example, a 1/4-inch portable electric drill will hold any straight-shank drill up to and including a 1/4-inch drill.

The revolutions per minute (rpm) and the power the drill delivers are the most important points when a drill is being chosen for a particular job. The speed of the drill motor decreases as the size of the drill increases. The speed of electric power tools used on explosive-loaded components must NOT exceed 2,000 rpm. Therefore, you must be careful in selecting a tool for a particular job.

When using nonferrous wire-wheel brushes or fabric wheels with a drill, the diameter of the wheels must not exceed 8 inches. Electric nonferrous wire-wheel brushes and fabric wheels are especially useful on work where a large amount of paint must be removed from the surface to be painted. When using a nonferrous wire-wheel brush or a fabric wheel, move it smoothly and lightly over the surface. Never allow the brush to stay in one place too long; it could cause a hot spot on the metal and will create an explosive hazard. The brush could also cut into the metal, leaving a depression that may be cause for the rejection of the component.

Electric power tools are authorized for use in mine assembly, disassembly, and maintenance. Electric tools must be electrically grounded according to with applicable safety regulations in volume 1 of *Ammunition and Explosives Ashore and Safety Regulations for Handling, Storing, Production, Renovation, and Shipping*, NAVSEAOP 5. No tools of any type (power or manual) are authorized for use at the intermediate level on filling hole covers.

PNEUMATIC POWER TOOLS.—Pneumatic rotary and reciprocating motor power tools are also authorized for use on explosive-loaded mine cases that are properly grounded and that have no EEDs installed. The same restrictions that apply to electric power tools also apply to rpm and size of nonferrous and fabric wheels used with pneumatic power tools.

Pneumatic wrenches are designed to give optimum performance with 90 psi of air at the tool when running. Every effort should be made to ensure that the line pressure is correct and that the pressure or the

volume has not been reduced at the tool by undersized hose, hose menders, undersized bushings, or quick-connect couplings that restrict the air flow.

PAINTING EQUIPMENT

In the Navy, the basic painting equipment includes spray guns and their associated equipment, paint rollers, and paint brushes. Each of these items is discussed in the following subsections.

Spray Guns

A spray gun is a precision tool in which air and paint are separately directed into the area where the paint is atomized before it is sprayed on the surface being painted. The mixing area may be outside or inside the spray cap of the gun.

Spray guns are classed according to where the air and the paint are mixed (external or internal), how the air is controlled (bleeder or nonbleeder), and how the gun is supplied with fluid (suction feed or pressure feed).

- **External-mix gun:** In an external-mix gun, the air and the paint are mixed outside in front of the external-mix air cap. This type of gun requires high air pressure; thus, it uses more cubic feet of air per minute than an internal-mix gun. Atomization of the paint is extremely thin and the size of the spray pattern can be controlled. There is no wear on the nozzle. By the use of different nozzles, an external-mix gun works with both suction and pressure feed systems. See figure 1-11.

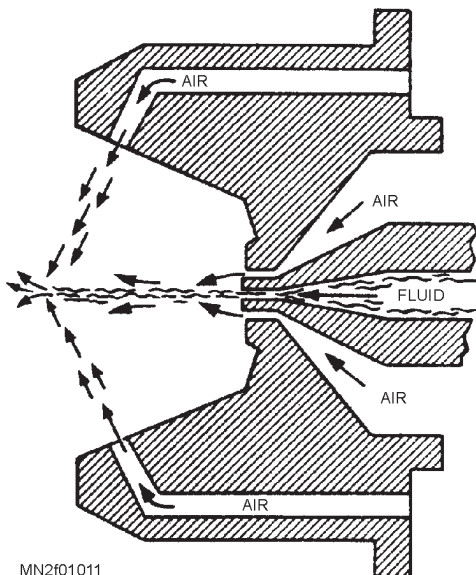

MN2f01011

Figure 1-11.—External-mix air cap.

- **Internal mix gun:** In an internal-mix gun, the air and the paint are mixed within the internal-mix air cap. In this type of gun, atomization of the paint is coarse, and the spray pattern is fixed. The gun works only with a pressure feed, but the pressure is lower and the amount of air used is less than for the external-mix gun. Because atomization of the paint is coarse, more paint is applied on each pass. See figure 1-12.

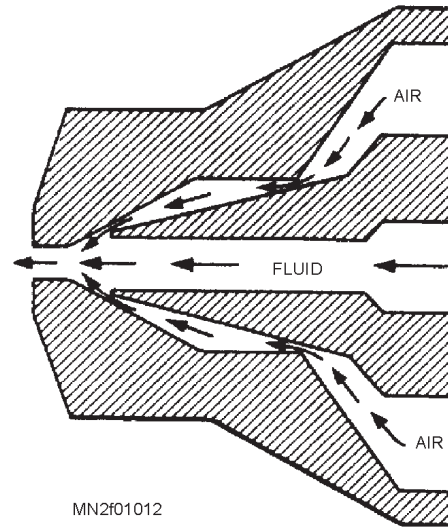

MN2f01012

Figure 1-12.—Internal-mix air cap.

- **Bleeder gun:** A bleeder gun allows the air to leak or bleed from some part of the gun to prevent the air pressure from building up in the hose. In this type of gun, the trigger controls the fluid. The gun is generally used with a small air compressor that has no pressure control on the air line.
- **Nonbleeder gun:** A nonbleeder gun is equipped with an air valve that shuts off the air when the trigger is released. It is used with a compressor that has a pressure-controlling device.
- **Suction-feed gun:** A suction-feed gun has a suction-feed air cap that draws the fluid from the container by suction in about the same way that an insect spray gun operates. The suction-feed guns are usually used with one quart (or smaller) containers. See figure 1-13.
- **Pressure-feed gun:** A pressure-feed gun operates by air pressure. The air pressure forces the fluid from the container into the gun. This type of gun, with a pressure-feed air cap, is used for large-scale painting. See figure 1-14.

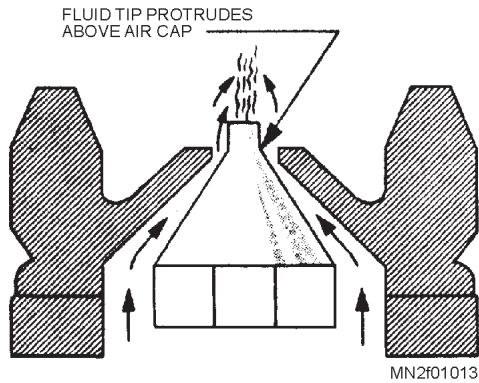

Figure 1-13.—Suction-feed air cap.

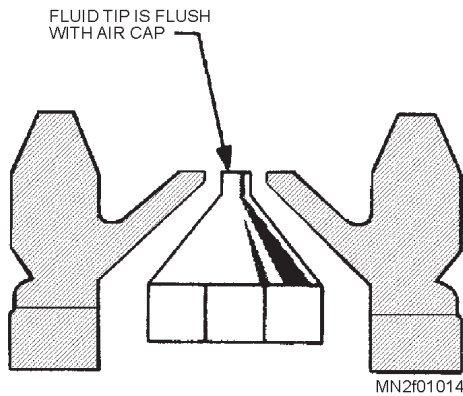

Figure 1-14.—Pressure-feed air cap.

SPRAY GUN ASSEMBLIES AND COMPONENTS.—The two main assemblies of a spray gun are the gun body and the spray head. Each assembly is a collection of small parts designed to do specific jobs.

- **Gun body:** The principal parts of the gun body assembly are shown in figure 1-15. The air valve controls the air supply and is operated by the

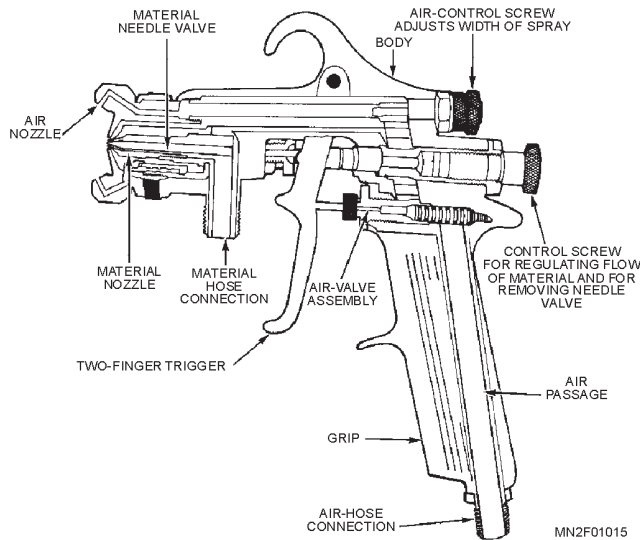

Figure 1-15.—Cross section of a spray gun.

trigger. The air-control screw regulates the amount of air supplied to the spreader horn holes of the cap, thus varying the paint pattern. The adjustment has a dial that can be set to give the pattern desired. The fluid needle adjustment controls the amount of spray material that passes through the gun. The spray-head locking bolt locks the gun body and the removable spray head together.

- **Spray head:** Most spray guns have a removable spray-head assembly. This type of gun has several advantages. For example, it is easier to clean; it permits you to change the head quickly when you want to use a new material or a new color of material; and the head is replaceable when damaged. The principal parts of the spray-head assembly are the (1) air cap, (2) the fluid tip, (3) the fluid needle, and (4) the spray-head barrel. The fluid tip regulates the flow of the spray material into the air stream and encloses the end of the fluid needle. The spray-head barrel is the housing that encloses the spray-head mechanism. See figure 1-16.

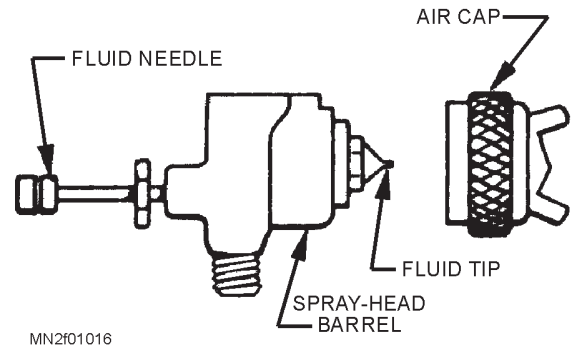

Figure 1-16.—Principal parts of the spray-head assembly.

- **Material containers:** The material containers are the cups that hold the spray material before delivery to the gun. The type of painting job determines which of the several kinds of containers should be used. **Suction-feed cups** are used for small quantities of lightweight and medium-weight spray materials, such as lacquers. **Gravity-feed cups** are small and are attached directly to the top or side of the gun. Normally, they are used only on artist's and decorator's guns or on small touch-up guns. **Pressure-feed cups** are best for handling small quantities of enamels, plastics, or other heavy materials on jobs where fine adjustments and speed of application are needed. See figure 1-17.

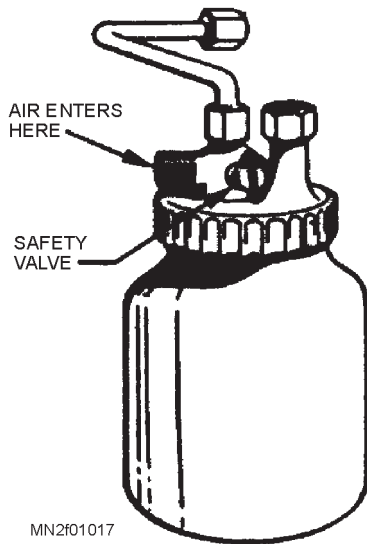

Figure 1-17.—Pressure-feed cup.

- **Hose lines:** The hose lines used for spray guns are of two types: one handles air; the other handles liquids. The air hose is usually made of braid-covered tubing of either one-braid or two-braid construction. The fluid hose is made of a special solvent-resistant material that can withstand the attacks of paint, lacquer, and similar liquids.
- **Air supply:** The compressed air that operates spray guns is supplied by either portable or installed compressors. The air pressure from the compressors is usually set from 100 to 125 psi. The pressure is reduced to spraying pressure by a pressure-regulator valve. When using air compressors, follow the manufacturer's operating instructions. To spray paint properly, ensure that the air is dry and free of dust. Since all air contains moisture and dust in varying amounts, some means must be provided to remove it. This is commonly done by an air transformer, frequently called an air separator or an air regulator. Air, passing through the transformer, enters through an air inlet and passes through a series of baffles and a filter chamber to a regulator diaphragm that adjusts the pressure. During normal weather conditions, the transformer should be drained daily. If the weather is damp, it should be drained several times daily. To drain the transformer, open the drain valve on the bottom of the unit. Change the packing and filter units also at regular intervals. See figure 1-18.

SPRAY GUN OPERATION.—When the trigger of a spray gun is squeezed, the air valve that admits

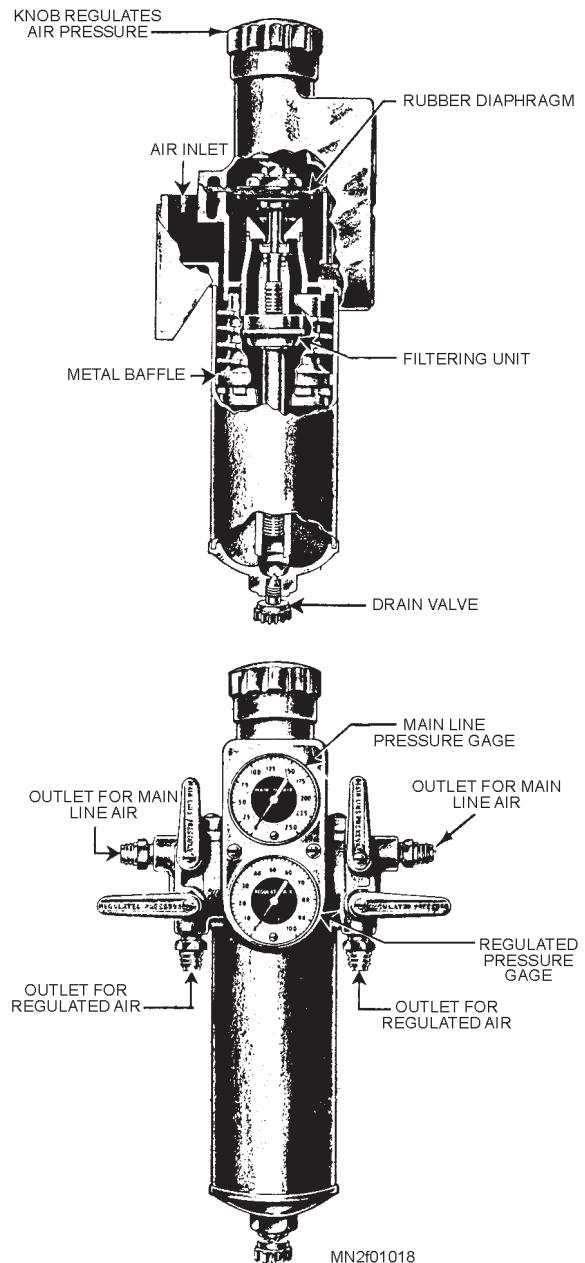

Figure 1-18.—Air transformer.

compressed air through the air inlet opens. The air then passes through the gun body into the spray head. In the most common types of spray heads (external-mix), the air does not come in contact with the paint inside the gun, but is blown out through small holes drilled in the air cap. The paint is blown out of the nozzle in a thin jet. The force of the air striking the paint breaks the jet into a fine spray.

You can control this spray to produce various patterns by setting the air control screw that regulates the spreader adjustment valve.

- To get a round spray, turn the control screw counterclockwise.

- To get a fan spray, turn the control screw clockwise.
- To increase the flow of paint, turn the fluid control screw clockwise.
- To maintain the same coverage over a wider area, increase the flow of paint as you increase the width of the spray.

The use and handling of a spray gun are learned best by practice. The following paragraphs describe how to use a spray gun properly and include tips to help you use the gun more efficiently:

- Before starting to paint with a spray gun, check the adjustments and the operation of the gun by spraying paint on a surface similar to the one that you intend to paint.
- To do good work, use a minimum amount of pressure, holding the gun away from the work normally from 6 to 10 inches. However, there are no set rules for spray gun pressure or for the distance of the spray gun from the surface to be painted. The pressure and the distance vary considerably with the type of nozzle, the paint used, and the surface to be painted.
- For the paint to spray properly, always keep the gun perpendicular to and at the same distance from the surface being painted. Start the stroke before squeezing the trigger, and release the trigger before completing the stroke. If you do not hold the gun perpendicular or if you hold it too far away from the surface being painted, part of the paint spray will evaporate and will strike the surface in a nearly dry state. This condition is called *dusting*. If you fail to start the stroke before squeezing the trigger or if you fail to release the trigger before ending the stroke, the paint will build up at the end of the stroke and will run or sag. If you arch the stroke, you will not be able to deposit the paint in a uniform coat. See figures 1-19 and 1-20.
- When spraying corners (both inside and outside), stop 1 or 2 inches short of the corners. Paint both sides of the corner the same. Then turn the spray gun on its side and, starting at the top, spray downward, coating both sides of the corner at the same time. See figure 1-21.
- When spraying a large area where small parts and pieces protrude, first coat the protruding items lightly and then coat the entire surface. For example, when painting a mine, first paint

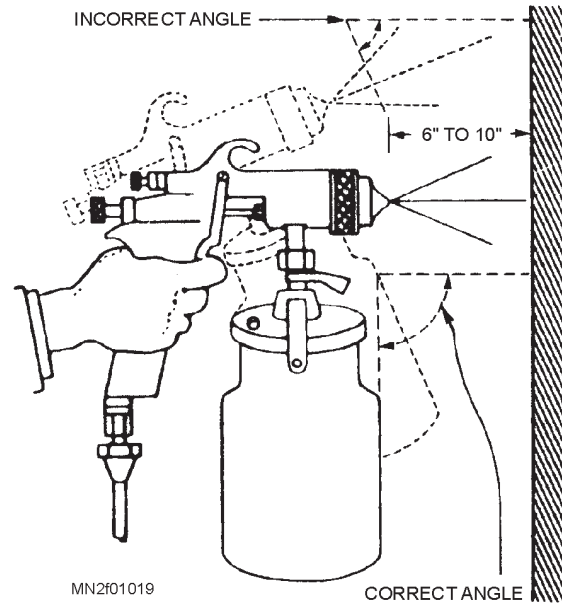

Figure 1-19.—Holding the spray gun perpendicular to the surface.

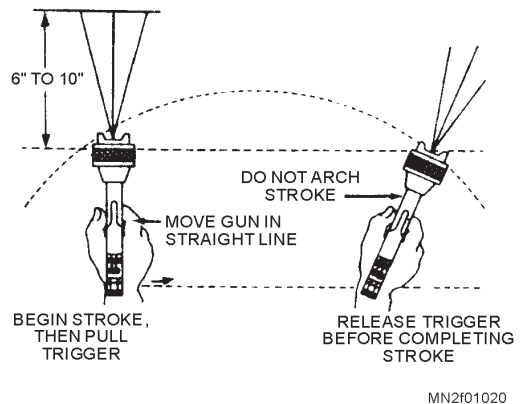

Figure 1-20.—Proper spray gun stroke.

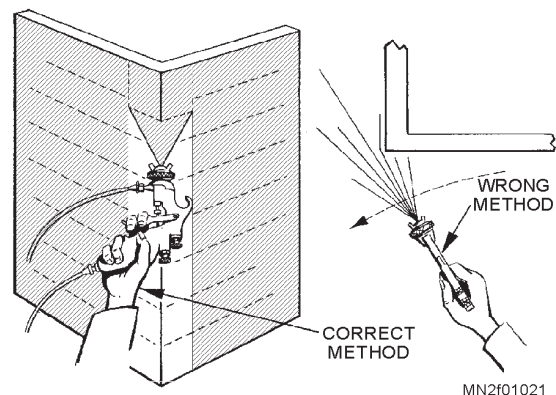

Figure 1-21.—Right and wrong ways of spray painting corners.

around the filling hole cover and the spoiler, both outside and inside the spoiler. Then paint the entire mine. This procedure eliminates a lot of touching-up later.

COMMON SPRAY PAINT DEFECTS.—The most common defects in sprayed paint are orange peel, runs and sags, pinholes, blushing, peeling, and bleeding.

- *Orange peel* is the general term used to describe a dry painted surface that has a pebbled texture resembling an orange peel. It can be caused by the improper use of thinners, a spray that is not fine enough, too much or too little distance between the gun and the surface, improper mixing of materials, drafts, or low humidity.
- *Runs and sags* are usually the result of paint that is too thin. They can also result when too much material is sprayed on the surface, the spraying stroke overlap is too great, improper adjustments of the spray gun and pressure are being used, or dirty or partially clogged air or fluid passages cause uneven distribution.
- *Pinholes* can be caused by water or excessive thinner in the paint. Excessively heavy applications of quick-drying paint also cause pinholes. In either case, small bubbles form and break when the paint is drying, leaving small holes.
- *Blushing* resembles powdering of the paint. The cellulose material in the paint separates from the solvent and returns to its original powder form. Water is usually the cause of blushing, either moisture on the surface to be sprayed or excessive moisture in the air. To correct a blushing defect, remove the defective coat, because the moisture is trapped in the material and remains there unless the material is removed. Then repaint the area.
- *Peeling* is usually caused by carelessness in cleaning the surface to be painted. Before paint spraying is attempted, the surface to be painted must be thoroughly cleaned. Cheap spray materials sometimes result in poor adhesion, but this should be no problem when standard Navy paints are used.
- *Bleeding* occurs when the chemical compounds of a previous coat discolor the finish coat. When a paint contains a strong aniline dye (a synthetic organic dye), bleeding results when another color is sprayed over it.

SPRAY GUN CARE.—Spray guns (including paint containers and hoses) must be cleaned thoroughly after each use. When using solvent in cleaning spray guns, be extremely cautious because

possible damage may occur to the packing around the valves. To clean a container-type gun, refer to figure 1-22 and follow these procedures:

1. Remove the container from the gun.
2. Hold a cloth over the air cap and pull the trigger.
3. Empty the container.
4. Pour in a small amount of solvent.
5. Attach the container to the gun and spray the solvent through the gun to clean out the passageways.
6. Soak the air cap in cleaning solvent.
7. Replace the air cap.

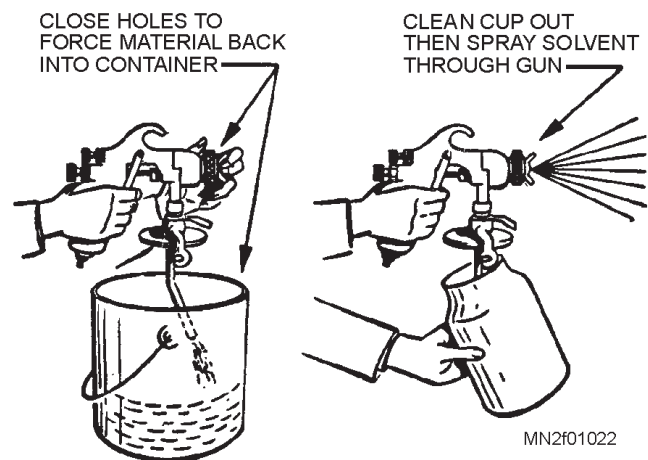

Figure 1-22.—Steps in cleaning a container-type gun.

Some spray gun troubles, possible causes, and remedies are listed in table 1-2.

Spray Gun Lubrication.—A spray gun needs occasional lubrication. To do this, remove the fluid needle packing and soften it with oil. Coat the fluid needle spring with grease or petrolatum. Figure 1-23 shows the location of these parts and the oil hole where you place a few drops of light oil.

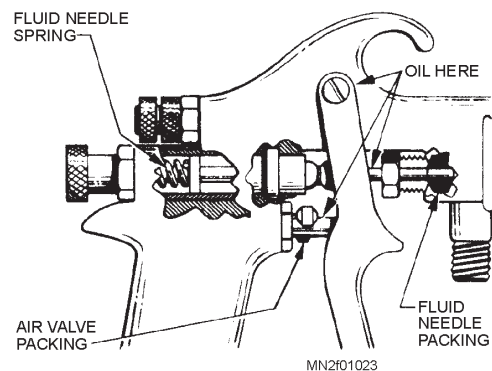

Figure 1-23.—Lubrication points of a spray gun.

Table 1-2.—Spray Gun Troubles, Possible Causes, and Remedies

TROUBLES	POSSIBLE CAUSES	REMEDIES
Air leaks from front of gun	Foreign matter on valve seat Worn/damage valve seat Sticking valve stem Bent valve stem Loose packing nut	Clean Replace Lubricate replace Adjust
Fluid leaks from front of gun	Worn/damaged fluid tip/needle Foreign matter in fluid tip Packing nut too tight Wrong size needle	Replace Clean Adjust Replace
Jerky or fluttering spray (section and pressure feed)	Insufficient material in container Tipping container to excessive angle Obstructed fluid passageway Loose/cracked fluid tube Loose fluid tip Damaged tip seat	Refill Take greater care Clean Tighten/replace Tighten/replace Tighten/replace
Jerky or fluttering spray (suction feed only)	Material too heavy Clogged air vent in container lid Loose/damaged coupling nut/cup lid Fluid tube resting on bottom	Change to pressure feed Clean Tighten/replace Use proper fluid tube
Defective spray pattern	Air cap horn holes partially plugged Dirt on air cap/fluid nozzle	Rotate air cap 1/2 turn and spray another pattern. If defect is inverted, fault is on/in air cap. If pattern is same, fault is on/in fluid nozzle. Clean proper part.

Spray Head Removal.—Removal of the spray head may be necessary for cleaning or repair. You may need to change the head when the color of the paint is changed. With modern spray guns, this is a fairly simple operation. Refer to figure 1-24 and follow the procedures in table 1-3.

AIRLESS SPRAY PAINTING.—Airless spray painting uses hydraulic pressure. The equipment is similar to conventional spray equipment except that the pressure is generated by a hydraulic pump. Atomization of the paint is accomplished by forcing it through a special-shaped orifice at a pressure up to

3,000 pounds psi. This pressure allows you to apply paint to the surface as rapidly as you can move the gun.

Airless spray painting usually permits the use of products with a higher viscosity. Less thinning is required, a better film is obtained, and the production is increased. A single hose leading to the gun makes it easier to handle and causes less tiring to the painter. The lack of overspray offers two other advantages: cleanup is easier and masking is minimized.

Because of the high pressure in an airless spray gun, you must ensure that your personnel receive complete instructions on the proper use of airless spray

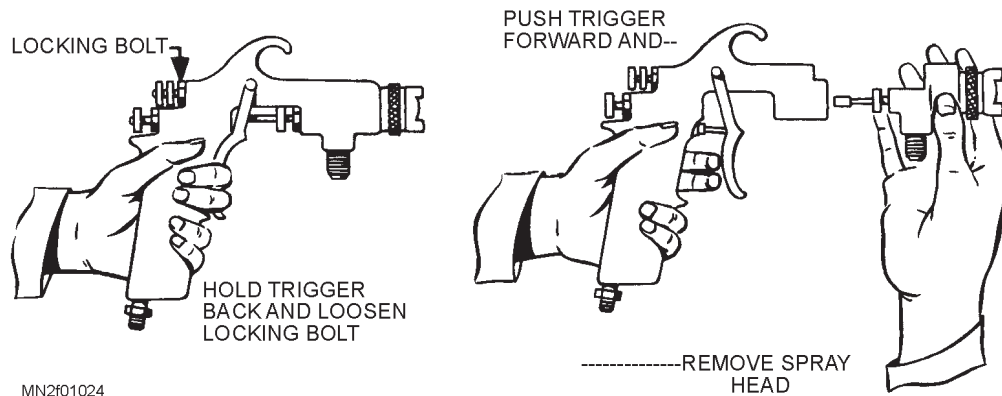

Figure 1-24.—Lubrication points of a spray gun.

Table 1-3.—Spray Head Removal and Replacement Procedures

STEP	REMOVAL PROCEDURES	REPLACEMENT PROCEDURES
1	Remove the gun from the air hose line.	Push the trigger forward.
2	Hold the gun in your left hand and pull the trigger all the way back.	Insert the spray head.
3	Loosen the locking bolt with the wrench provided for that purpose.	Hold the trigger back.
4	Push the trigger forward as far as possible.	Tighten the locking bolt.
5	Pull the spray head forward.	

equipment before they are allowed to operate the equipment or to assist in its operation. Training must stress the potential dangers associated with the handling of airless spray paint equipment. Although safety features designed to minimize those dangers have been built in, amputations and deaths have resulted from careless use of this equipment, particularly when the spray tips were removed for cleaning. Before a spray tip is removed or adjusted or when spray operations are shut down for an extended period, turn the electrical power OFF and depress the gun trigger to bleed the line pressure.

Refer to the operator's manual supplied with each airless spray gun for the safety precautions peculiar to that model of gun. The following list of safety precautions must be observed when any airless spray gun is being used:

1. NEVER use airless equipment unless you are fully trained to do so.

2. NEVER allow an untrained person to use the equipment.
3. NEVER put your hands or fingers in front of the nozzle.
4. NEVER point the gun at a person.
5. NEVER work on or repair pressurized equipment. (The equipment must be turned OFF, the pressure released, and the trigger safety engaged before being disassembled.)
(TURNING OFF THE POWER DOES NOT RELEASE THE PRESSURE.)
6. NEVER spray a flammable solvent through the gun tip. (The high velocity generates static electricity, which could cause a fire or an explosion.)
7. NEVER plug leaks with fingers. Before use, check hoses for leaks, cuts, and wear. Replace any damaged hose.

8. NEVER leave a pressurized airless spray unit unattended.
9. ALWAYS secure connections to prevent leaks.
10. ALWAYS use personal protective equipment when using the spray gun. (Wear a supplied-air or organic vapor cartridge respirator with prefilters, goggles, chemical protective gloves, coveralls, and hearing protection.)
11. ALWAYS use the trigger lock when not actually spray painting (i.e., before wiping the tip). (Remove the tip guard only if spraying with it in place is impossible.)
12. ALWAYS remove the gun from the hose after flushing and when stowing it.
13. ALWAYS keep the trigger safety engaged when the gun is not in use.
14. ALWAYS obtain immediate medical attention for injuries. (Report the nature of the injury and the type of fluid or solvent used.)

MATERIALS NOT TO BE USED IN SPRAY GUNS.—As a general rule, Navy paints, enamels, lacquers, synthetics, varnishes, and shellacs may be used in ordinary spray guns. Material containing small gritty particles, such as alkaline coverings, rubber hose paints, plastics, and mastic paints, must NEVER be used in standard spray guns.

Paintbrushes

Paintbrushes are only as good as the care given them. The best paintbrush can be ruined very quickly if not properly cared for. By following the suggestions given in the next few paragraphs, you will find that your paintbrushes will last much longer and will give you better service.

When paintbrush bristles were set in wood, painters would dampen the wood to cause it to swell and hold the bristles more tightly. However, nearly all modern paintbrushes have bristles set in rubber or in a composition material. Therefore, to wet the end of the handle that holds the bristles serves no useful purpose; in fact, it only damages the brush since it tends to rust the metal band (ferrule).

To make a new natural bristle brush more flexible and easier to clean, rinse it in paint thinner and soak it in boiled linseed oil for about 48 hours. Before using the brush, drain the oil from it, wipe its bristles clean, and wash it in a solvent or other oil remover. (Synthetic

bristle brushes do not require special treatment before use.)

Every paint locker should have a container with divided compartments for stowing brushes that are used for short periods with different materials, such as paint, varnish, and shellac. The containers should have tight covers and a means of hanging the brushes so the entire length of the bristles and the lower part of the ferrule are covered by the paint thinner or linseed oil in the container. The bristles must not touch the bottom of the container or they could become damaged. A paintbrush with distorted bristles is a very inefficient tool.

When brushes are to be used the following day, they should be cleaned with the proper paint thinner and hung in an empty compartment in the container. Brushes that are not to be used soon should be cleaned in thinner, washed in soap (or detergent) and water, rinsed thoroughly in freshwater, and hung to dry. After drying they should be wrapped in paper and stowed flat. Brushes should not be left soaking in water; the water will cause the bristles to separate into bunches or become flared or bushy.

Remember: After using a brush, NEVER leave it in an open can of paint or exposed to the air. Clean the brush immediately after it is used, then stow it properly.

The proper cleaners for brushes used with different materials are listed in table 1-4.

Paint Rollers

Paint rollers are designed to apply a uniform coat of paint over a large area quickly with less effort than with a brush. Paint rollers used in the Navy consist of replaceable, knotted fabric rollers with solvent-resistant paper cores. The roller is supported on corrosion-resistant steel that rotates on a metal shaft.

After use, the fabric cylinder should be stripped from the core, cleaned in the solvent recommended for the paint used, washed in soap and water, rinsed thoroughly, and replaced on the core to dry. Combing the pile of the fabric while it is damp prevents matting.

PAINT COMPOSITION

Paint consists of four essential ingredients: pigment, vehicle, drier, and thinner. The pigment is grounded into the vehicle and the drier and the thinner are added. This section describes these four elements.

Table 1-4.—Proper Cleaners for Paintbrushes

MATERIALS USED	CLEANERS
Natural and synthetic oil-based paints and varnishes	Paint thinners or mineral spirits
Latex emulsion	Water
Shellac	Alcohol
Lacquer	Lacquer thinner

Pigment

Pigment is used to give color to the paint. Some pigments also increase the quality of the paint. Inert pigments are chemically stable and do not affect color or destroy the life of the paint vehicle. They are used to provide a less-expensive base for certain kinds of paint colors, to decrease the amount of active pigment in the paint, and to help prevent settling and caking of the pigment in the container. Some common inert pigments presently in use are barium sulfate, calcium carbonate, whiting, magnesium silicate, talc, and silica.

Vehicle

The vehicle, usually referred to as the *base*, is the liquid portion of the paint that acts as the binder and the brushing medium for the pigment particles. The base wets the surface to be painted, penetrates into the pores, and ensures proper adhesion of the film formed by the drying vehicle.

Until recently, the base of most paints was an oil, such as linseed oil. Today, only a few Navy paints contain raw oil. The base of some Navy paints is processed oil in combination with a synthetic resin. Other paints have a vinyl base and some have a water base.

Most oil-based vehicles dry partially by evaporation, partially by oxidation, and partially by polymerization. Polymerization is the process where two or more similar molecules combine chemically to form a larger molecule of a new substance. Older paints contained raw oils, had poor physical properties when dry, and dried slower than modern paints. For these reasons, raw oils should NEVER be added to a Navy paint. If the paint is thick and needs to be thinned,

add only a recommended thinner. Never add diesel oil, varnish, or other nonrecommended material.

Driers

When mixed with oil, certain metallic compounds add to the drying properties of the paint. They are driers and, as used in the Navy, consist chiefly of compounds of cobalt naphthenates.

A paint drier acts as a conveyor of oxygen. It takes the oxygen from the air and adds it to the oil. This process speeds the oxidation of the paint. Without the drier, absorption of oxygen would be too slow, and it would take too long for the paint to dry.

Thinners

Thinners reduce the consistency of paint to the proper degree for application by spraying, brushing, or rolling. Thinners also increase the penetration of paint into the surface being painted, and they cut down on gloss. Too much thinner, however, dilutes the vehicle too much. As mentioned earlier, the vehicle is a binder; if it is diluted excessively, the durability of the paint is affected. In flat paints, the proportion of the oil is deliberately reduced by thinners to cause the paint to dry without gloss.

PAINT PREPARATION

No matter how high the quality of the paint, it will give poor service if it is not thoroughly mixed before it is applied. When paint stands for a long period of time, the pigment settles to the bottom of the container and the vehicle rises to the top. Subsequently, the paint must be remixed before use.

If you do not have a mechanical mixer, the best system for mixing is to pour off most of the vehicle into an empty can and mix the remainder thoroughly. Then

add a small amount of the remaining liquid at a time until all the vehicle has been added and the consistency of the paint is uniform. To ensure that the paint is thoroughly mixed, pour the paint back and forth a number of times between two cans. This process is known as *boxing* and ensures a smooth and even mixture.

PAINT APPLICATION

Smooth and even painting depends as much on the method of application as it does on the quality of the paint. Different painting equipment (such as spray guns, brushes, or rollers) is used for different purposes. Ensure that you use the right equipment and that it is kept in good condition,

When you are painting, keep the following items in mind:

- The thickness of the coats can determine if the job is completed satisfactorily. Thick coats of paint tend to crack and peel. They are likely to be uneven and they tend to show marks and scratches more readily than thin coats. They do not dry as hard a finish as thin coats. For a complete list of the paint systems applicable to mines, refer to NAVSEA SW550-AA-MMI-010.
- Painting should not be done when the temperature is below 32°F. In cold weather, moisture condenses on the surfaces and the paint does not stick. Also, the thinner evaporates very slowly and increases the drying time. For best results, painting should be done in warm weather with the temperature between 60°F and 80°F.
- Humidity and ventilation are also important conditions. Excess humidity may cause condensation on the surface to be painted, making painting difficult. But humidity can be reduced by proper ventilation. Proper ventilation is necessary to furnish the oxygen necessary to dry the paint properly.

Striping

You may be required to apply stripes to a painted surface or to an unpainted surface. Striping is relatively easy if you use masking tape. But after painting, be careful when removing the masking tape. Pull the tape off in a diagonal direction and back upon itself. If you fail to remove the tape in this manner, you may damage

the finished painted surface. The procedure is a little different for each situation.

STRIPING PAINTED SURFACES.—Use the following procedures to stripe painted surfaces:

1. Decide the size and the position of the stripe.
2. Apply masking tape firmly to each side of the area where the stripe is to be.
3. Paint the areas not covered by the masking tape.
4. Protect the painted surface against daubs and oversprays by using protective covering in addition to the masking tape.

STRIPING UNPAINTED SURFACES.—Use these procedures to stripe unpainted surfaces:

1. Paint the stripe wider than the actual stripe is to be.
2. After the paint is dry, apply masking tape to the area where the stripe is to be. To ensure that the tape is smooth and firmly attached, rub or roll it.
3. Paint the entire surface, including the masking tape, with the finish coat.
4. After the paint is dry, remove the tape.

PAINTING SAFETY

For a safe painting operation, responsibility and training are the two most important factors. The importance of these factors must be clearly understood by all personnel associated with the painting operation.

Personnel, concerned with the painting operation, must also be made aware of the hazards associated with the handling and use of flammable materials and with applicable safety precautions. This information must be a part of each person's job training.

Every painting operation exposes the personnel in the immediate area to some conditions and situations that are actually or potentially dangerous. The use of toxic and flammable materials and pressurized equipment presents potential hazards. Hazards may also be inherent in the working conditions or may be caused by inexperience of the operator, lack of training, or just pure carelessness.

Therefore, awareness of all potential hazards is essential. To minimize existing hazards and to improve the efficiency of the painting crew, ensure that your personnel are so well-trained that they automatically take precautionary measures.

Safety Practices

When planning painting operations, pay special attention to the following factors:

1. Paint materials
2. Surface preparation materials
3. Painting equipment
4. Environment
5. Experience of the painting crew
6. Degree of hazards

Remember that CARELESSNESS increases hazards. Shortcuts often produce unsafe working conditions, resulting in accidents, personnel injuries, and loss of time and materials. An element of risk is still present even when well-trained personnel follow prescribed safety procedures. However, if safety precautions are carefully observed at all times, the risk of accidents will be minimal.

Spray-painting equipment has been known to produce several thousand volts of static electricity. For this reason, the spray gun nozzle and any explosive items being painted must be grounded to the same point during the spray-painting operation. When high-voltage spray-painting equipment is used or installed, it must be done according to the National Electrical Code.

The application of paints, varnishes, lacquers, and enamels by the spraying process is more hazardous than the application by brush for several reasons:

1. There is a greater volume and concentration of work.
2. Spraying produces a residue of flammable properties subject to spontaneous ignition.
3. Health hazards may exist because of potentially harmful substances that may be present (such as lead, benzol, and silicone). Therefore, all safety precautions must be strictly observed. Personnel must continuously observe good habits of personal hygiene to avoid the health hazard of lead poisoning. Any person with a history of chronic skin disease, allergies, or respiratory problems must not be permitted to work with paint compounds and thinners. Personnel, handling painting materials, must prevent the materials from coming in contact with their skin or eyes and must avoid inhaling the mist or vapors. A spray painter must wear gloves and

protective garments that fit snugly at the ankles, the neck, and the wrists. All exposed areas of the skin of the painter should be covered with a protective cream.

Respirators

Spray-painting guns break up the paint into a fine mist of paint pigments and vehicle or solvent vapors. The vapors and pigment can be health hazardous if you inhale them or allow them to contact your skin. Unless the spray area is equipped with local exhaust ventilation and tested for efficiency, personnel must wear respiratory protection.

An industrial hygiene survey of the ventilation system will determine if personnel need respirators and the type required. Respirator users must be medically screened and fit-tested to the respirator they will use according to the *NAVOSH Program Manual*, OPNAVINST 5100.23, or the *NAVOSH Program Manual for Forces Afloat*, OPNAVINST 5100.19.

There are two types of respirators: air-purifying and supplied air. The correct respirator must be selected for the hazard.

1. Air-purifying respirators: Air-purifying respirators have filters or cartridges to trap or absorb air contaminants. For spray painting, personnel must be protected against the organic vapors of the paint vehicle, or solvent, and against the pigment mist. This requires an organic vapor cartridge with a mist prefilter over the cartridge. The cartridge and the prefilter attach to either a full-facepiece or half-facepiece respirator mask. See figure 1-25. For sanding operations, a cartridge; rated as protection against dust, is substituted on the mask. See figure 1-26.
2. Supplied-air respirators: Supplied-air respirators are used when there is an oxygen deficiency or the concentration of air contamination is too high to use air-purifying respirators. They are used when the air contaminant has no warning properties (such as smell) to alert the wearer of exposure to the hazard. The air is supplied to a hose-line mask, through an air compressor, a breathing air pump, or a self-contained breathing apparatus (SCBA). See figure 1-27. If a breathing air pump or a compressor supplies the air, the air must be tested and certified for breathing.

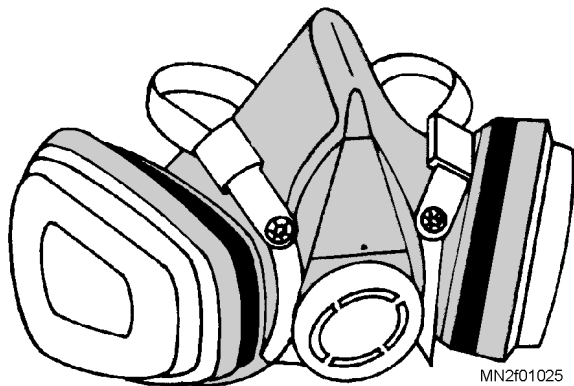
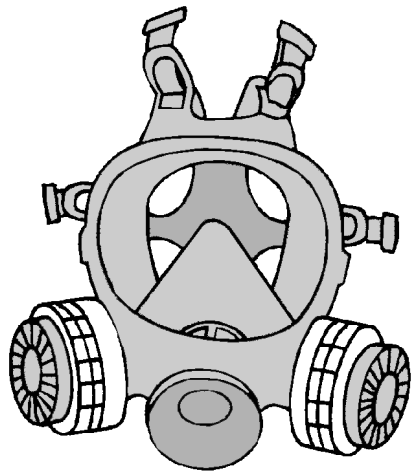

MN2f01025

Figure 1-25.—Full-facepiece and half-facepiece cartridge respirators with prefilters.



MN2f01026

Figure 1-26.—Dust respirator.



MN2f01027

Figure 1-27.—Supplied-air respirator hose-line mask.

- a. Sandblasting and spray-painting hoods are a type of supplied-air respirators. The hood fits over the entire head and neck and air flows into the hood continuously. This provides a positive pressure inside the hood, preventing intrusion of air contamination. Air-supplied hoods provide eye protection and do not require fit-testing.
- b. Sandblasting hoods are usually made of leather or heavy material to resist deterioration from the abrasive sand. Spray-painting hoods may be made of disposable, paper-like material with replaceable, peel-off window covers. See figure 1-28.

BATTERY REFRIGERATOR STORAGE

Electrical energy for U. S. Navy mines is supplied by dry-cell batteries, which comprise a variety of

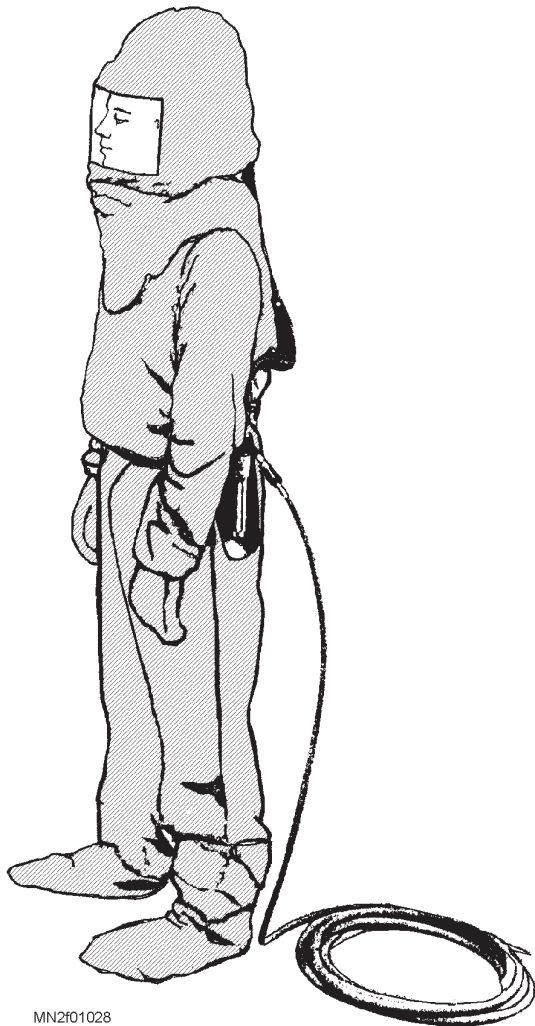

MN2f01028

Figure 1-28.—Disposable spray-painting hood.

chemicals in different combinations. These dry-cell batteries have a fixed shelf life when stowed within a specified temperature range.

For Leclanche, alkaline, and mercury cells, the specified range is 56°F to 80°F. For cadmium-mercury cells, the specified range is 21°F to 95°F. At these ranges, batteries deteriorate at a normal rate. At temperatures above these ranges, batteries deteriorate at a rate faster than normal. Conversely, they deteriorate at a rate slower than normal at temperatures below these ranges.

An exception to these temperature requirements is the Mk 131 battery which, until activated, is stowed in ordinary ambient temperatures. Once the Mk 131 battery is activated, it must be placed in refrigerated stowage with temperate ranges for mercury cells.

Batteries should be stowed at the lowest possible temperature, but not below the minimum limits listed in NAVSEA SW550-AA-MMI-010 or the batteries could be damaged. For optimum service, stow batteries

at the nominal temperatures listed in the above publication.

Although manufacturers package batteries in special packing, batteries are fragile and must be handled with care, regardless of the temperature at which they are stowed or shipped. Batteries frozen to 30°F are brittle and handling should be minimum.

Batteries should be stowed separately by type and lot and, where possible, arranged so that the older batteries can be removed without disturbing the newer lot. Where space permits, stacks should be kept small to allow easy handling. Generally, it is preferable to leave an air space along the walls and at the top and bottom of the chamber with several aisles through the central area. The size of the space is dependent on the location and capacity of the circulating fan. Stacking in front of the entrance to a vestibule can aid in temperature maintenance within the refrigerator, particularly during receipt and issue.

BATTERY THAWING

Depending on operational requirements, batteries may be thawed by using any one of three methods: normal thaw, standard rapid thaw, or alternate rapid thaw.

1. Normal thaw procedure: Time permitting, the normal thaw procedure is preferable and should be used because handling is kept to a minimum and the batteries do not accumulate moisture since they are not removed from their containers. It requires from 24 to 48 hours to reach a point where the battery temperature is high enough to permit testing.
2. Standard rapid thaw procedure: The batteries are removed from their containers and polyethylene bags, freeing the batteries from all packaging. This procedure is commonly referred to as *preferred rapid thaw procedure*.
3. Alternate rapid thaw procedure: The batteries are removed from their outer containers, but not from their polyethylene bags. This method allows the batteries to remain relatively dry since the water condensation forms outside the polyethylene bag and not on the battery.

Immediately after thawing the batteries, they may be tested without damage. However, batteries could fail class-B testing at this time solely because their internal temperature is too low. Batteries failing this

test should be set aside for an additional 24 hours and retested.

Anytime a battery is thawed from a frozen state, a minimum of 2 months should be added to the effective storage time on the battery history card. If the battery remains thawed for more than 2 months, the time added to the battery history card should be the actual time, multiplied by the appropriate factor from the effective storage time factors in NAVSEA SW550-AA-MMI-010.

For further information on battery storage, battery thaw procedures, and battery effective storage time, refer to NAVSEA SW550-AA-MMI-010.

RECOMMENDED READING LIST

NOTE: Although the following references were current when this NRTC was published, their continued currency cannot be assured. When consulting these references, keep in mind that they may have been revised to reflect new technology or

revised methods, practices, or procedures; therefore, you need to ensure that you are studying the latest revision.

Ammunition and Explosives Safety Ashore Regulations for Handling, Storing, Production, Renovation, and Shipping, NAVSEA OP 5, Vol. 1, Naval Sea Systems Command, Washington, DC, 1990.

Handling, Packaging, Storing, and Transportation of Underwater Mines and Destructors for Shore-Based/Shipboard Operations, NAVSEA SW023-M3-WHS-010, Naval Sea Systems Command, Washington, DC, 1990.

Mine Components A through C; Description and Class-B Criteria, NAVSEA SW550-AA-MMI-010, Naval Sea Systems Command, Washington, DC, 1988.

Underwater Mine Maintenance System, NAVSEA SW550-FO-PMS-010, Naval Sea Systems Command, Washington, DC, 1990.

CHAPTER 2

MINE HANDLING AND STORAGE

LEARNING OBJECTIVES

Upon completing this chapter, you should be able to do the following:

1. Recognize the proper handling and storage of mines and explosive materials.
2. Determine the requirements, principles, and applications necessary for the quantity-distance requirements of an operating building and storage area.
3. Differentiate between the various types of handling gear and their uses in handling explosive-loaded mines.

Explosive devices, ranging from mines to initiating devices, are dangerous and are designed for specific purposes. When explosive devices are manufactured, every effort is made to ensure that they are as safe as possible when they are handled. But, even the least-sensitive explosives can detonate if they are subjected to careless or improper handling. Any negligence can result in equipment damage, personnel injuries, and/or loss of life.

The history of accidents involving ammunition and explosives illustrates that avoidable circumstances existed in practically every incident where the cause could be determined. Complete understanding and strict observance of prescribed safety regulations are necessary to eliminate unsafe acts and conditions that can cause preventable accidents. Tasks performed repeatedly, no matter how dangerous, are likely to become routine and lead to carelessness. Therefore, constant alertness on the part of all personnel and intelligent, close supervision by supervisors are required to help prevent accidents. The most important areas to consider are handling and storage of ammunition and explosives.

All ammunition and explosives must be maintained in a high state of readiness at all times. In addition to proper preparation, assembly, and maintenance, ammunition and explosives must be handled and stored with extreme caution. Strict compliance with all prescribed safety standards, regulations, and procedures must be observed and enforced. Safety is always the first priority in any operation involving handling and storing ammunition, explosives, and other hazardous materials.

This chapter discusses safety during mine handling and storage, quantity-distance requirements, and handling equipment.

SAFETY DURING MINE HANDLING AND STORAGE

It is crucial that all personnel who handle or transport or are involved in the storage of explosives and other hazardous materials think, act, and live *safely* so that it becomes instinctive.

Accidents are usually the result of failure to follow regulations, failure to understand hazards, or failure to take necessary precautions. In each of these cases, failure indicates human error, carelessness, and/or poor judgment. All personnel must realize that when they do not follow safety regulations, they not only endanger their own lives but also the lives of their fellow workers. In the Navy, the responsibility for safety is an all-hands effort. This section addresses these responsibilities.

GENERAL SAFETY RESPONSIBILITIES

All personnel, engaged in operations involving the storage of ammunition and explosives, must be trained in all phases of the work they will perform. In addition, you must make them aware of the proper methods for performing tasks within their work area. Included in their training must be instructions in the following areas:

- Recognizing magazine identification markings

- Loading and unloading techniques within magazines and between magazines and conveyances
- Selecting and properly using materials-handling equipment
- Using protective equipment and protective clothing properly
- Operating fire-fighting equipment properly, knowing its availability and use, and knowing the procedures for reporting fires
- Knowing the procedures for detecting faulty ammunition and explosives
- Identifying ammunition and explosives by container markings and color codings
- Recognizing special hazardous characteristics of current inservice items as well as new items
- Knowing the proper handling procedures and storage arrangements for the ammunition and explosives
- Checking and observing placards or signs posted in the magazines
- Enforcing procedures for magazine security

Commanding Officer Responsibilities

The commanding officer is solely responsible for the safe handling, the transportation, and the storage of explosives of the activity and must exert the same active, aggressive leadership in safety that is exerted in all aspects of the command. The commanding officer also must ensure that all personnel who perform or supervise explosive operations are qualified and certified to perform their jobs and that personnel from other agencies (civilian contractors or other armed services) manage their activities according to established safety rules. The commanding officer is never excused for poor judgment, carelessness, and/or failure of subordinate personnel to follow safety regulations.

Supervisor Responsibilities

Supervisors must be thoroughly familiar with the provisions of *Ammunition and Explosives Safety Ashore, Regulations For Handling, Storing, Production, Renovation and Shipping*, NAVSEA OP 5, volume 1, and other pertinent publications and directives concerning operations involving

ammunition and explosives. As previously mentioned, safety is always the primary factor in any operation. You, as the supervisor, must be constantly alert for, and eliminate, potential hazards that may exist in your work area.

As a supervisor, you have no authority to waive or alter safety regulations; nor may you permit violations of these regulations by other personnel. When the words *shall*, *will*, and *must* are used with ordnance regulations or requirements, they mean *mandatory*, unless exempted by the Chief of Naval Operations (CNO) according to the provisions in *Waivers of Exemption from Explosives Safety Requirements and Policies and Procedures for Requesting*, OPNAVISNT 8020.14. When the words *may* and *should* are used with ordnance regulations or requirements, they mean the requirements shall be followed unless exceptions are authorized by the commanding officer of the shore station.

According to NAVSEA OP 5, a supervisor involved with ammunition and explosives is responsible for complying with all regulations. To accomplish this requirement, you, the supervisor, must take the following actions:

- Explain to all personnel under your immediate supervision the standard safety regulations, industrial hygiene safeguards, and precautions that must be followed; and enforce the observance of all safety regulations by each person. Furthermore, you must explain the characteristics of the ammunition, explosives, and other hazardous materials involved; the selection, use, and care of handling equipment—protective equipment as well as process equipment; and the hazards of fire, explosion, and other catastrophes that the safety regulations and industrial hygiene requirements are intended to eliminate or reduce.
- Instruct and train each person under your immediate supervision in the tasks that they are to perform. Instructions may be given directly or through experienced operators until you are satisfied that the person is capable of performing the work safely. Instructions must include information concerning magazine location, identification, location and use of bombproof shelters, first-aid kits, fire-fighting apparatus, guards, personal protective equipment, showers, plunges, and neutralizing solutions.

- Ensure that all personnel are certified and qualified to perform the job assigned to them and that their certification is current. You must report promptly to your immediate supervisor all personnel who, in your opinion, are not qualified to perform their assigned tasks. This includes any person engaged in operations involving the storage of ammunition and explosives who is suspected or known to be color blind.
- Investigate, or assist in the investigation of, all accidents involving operations, equipment, or personnel under your supervision and report, or assist in the preparation of the investigation results for submission to higher authority.
- Identify all persons entering or approaching the work area under your responsibility and determine their authority to enter and/or remain in the area. You must exercise your authority to eject any person whose presence and/or actions, in your opinion, are detrimental to safety.
- Enforce orders relating to the maximum number of persons permitted in the area. When the total number of persons (including operators, supervisors, inspectors, and transients) exceeds the number permitted in the magazine, magazine area, or work area, you are required to cease operations and to inform the personnel not regularly employed in the area of the excess number. If such notice is not effective in reducing the number of persons to the number permitted, you must suspend operations and promptly notify the appropriate authority. You must also cease operations when the amount of explosives exceeds the permissible quantity until such time that the excess amount is removed.
- Permit the use of only authorized tools and handling equipment for the operations in the manner prescribed by standard operating procedures. As the supervisor, you must require that tools and handling equipment be properly stored in designated locations when not in use. When a tool is lost or misplaced in an operating area or magazine, you must stop operations until the tool is found.
- Maintain cleanliness in the operational area, building, magazine, or magazine area. You must maintain all safeguards and prevent blocking of safety exits, aisles, and access to fire-fighting equipment.
- Forbid major repairs or changes to any magazine, machines, or equipment in operating and magazine areas containing hazardous materials, except according to specific instructions approved by the commanding officer. As the supervisor, you must enforce safety standards in magazines under repair in your area.
- Ascertain, before leaving at the close of work, that all conditions in the operating and magazine area under your control comply with orders relating to operation shutdown. When an operation is not relieved by an oncoming shift, you must make certain that windows and doors are closed and properly locked and that all master power and light switches outside buildings and magazines are turned off. When an oncoming shift relieves an operation or when a supervisor is relieved for any other reason, the off-going supervisor must make a complete report to the relief of any situation that requires immediate attention or that should be kept under observation.
- Enforce observation of the safety regulations concerning personnel protective clothing and equipment. You must make sure that protective materials (such as goggles, gloves, gauntlets, respirators, aprons, helmets, safety uniforms, safety shoes, and other implements, accessories, and appliances required for the safe performance of the work) are inspected, maintained, and/or replaced, as necessary.
- Be constantly alert for areas where lights, guards, or safety appliances are needed or where repairs are required, and all areas where sprays, showers, shelters, and exits or passageways should be accessible.
- Report in writing to your commanding officer or officer in charge any requests, suggestions, or comments you may have about safety standards.
- Alert your immediate supervisor of the need for explosive ordnance disposal (EOD) personnel to remove defective or suspect ammunition from the work area.

Technician Responsibilities

Technicians, or operating personnel, are responsible for reading, understanding, and strictly observing all safety standards, requirements, and

precautions applicable to their work or duty. According to NAVSEA OP 5, personnel in operations involving ammunition or explosives must comply with the following regulations:

- Immediately report to your supervisor any unsafe condition, personnel action, or equipment or material that you consider unsafe.
- Immediately warn other personnel when they are in danger by known hazards or by their failure to observe safety precautions.
- Always wear or use approved protective clothing or equipment when it is required.
- Immediately report to your supervisor any injury or evidence of impaired health either to yourself or to others occurring in the course of work or duty.
- Always be prepared, in the event of an unforeseen hazardous occurrence, to give an audible warning to other personnel and to exercise reasonable caution appropriate to the situation.
- Immediately report to your supervisor the presence of unauthorized personnel in the area.

GENERAL SAFETY REGULATIONS

Throughout your Navy career, safety has always been an important part of the job to which you have been assigned. In any ordnance-related rating, safety becomes even more important in your daily activities. Since the number of regulations is too great to include in this chapter, only the general regulations will be discussed in this subsection.

For detailed information on safety regulations, refer to volume 1 of NAVSEA OP 5 and to *Navy Transportation Safety Handbook for Ammunition, Explosives, and Related Hazardous Materials*, NAVSEA SW020-AG-SAF-010, volume 1.

Personnel Limit Regulations

The maximum number of personnel permitted in a specific area during an operation or situation is known as the *personnel limit*. Supervisors are responsible for ensuring that established personnel limits are not exceeded. When such limits are exceeded, operations must be ceased immediately and the situation corrected.

The number of persons allowed in the vicinity of ammunition or explosives or a given job shall, as much as possible, be kept to the minimum required to perform the work properly, safely, and efficiently. However, no person shall be permitted to work alone in a location if assistance from another person is not available immediately in the event of an accident.

Commanding officers of ordnance activities determine personnel limits inside and/or in the vicinity of operating buildings, magazines, transfer points, and pier and wharf areas. Normally, the commanding officer of the host command determines the personnel limits for Mobile Mine Assembly Unit (MOMAU) facilities. However, these limits may be established on the basis of recommendations by the MOMAG activity.

Some of the factors that must be considered in determining personnel limits are the

- type of building or area involved,
- nature of work involved, and
- degree of hazard present.

Established personnel limits must be strictly enforced to reduce the danger and extent of injury to personnel in case of an accident. In addition to personnel limits, the following requirements must be observed:

- Tasks that are not necessary in the accomplishment of a particular hazardous operation must be prohibited in the immediate vicinity of the hazard.
- Unnecessary personnel must be prohibited from visiting the area.
- The layout of concurrent operations in a building or an area must be subdivided into separate areas of operations or lesser operational hazards. These separate operations should be protected by substantial dividing walls, fire walls, operational shields, or other appropriate barricades.
- Placards stating the maximum number of personnel (workers and transients) permitted in an area must be conspicuously posted. The placards must be kept current and must use lettering large enough to be read by persons with average vision as they enter the building, area, or room.

- Three-inch minimum-height letters must be used on signs for operating building areas including, but not limited to, inert preparation rooms, assembly rooms, and paint spray rooms.
- One-inch minimum-height letters must be used on signs in service magazines, fuzing or defuzing cells, or rooms of similar size used for similar functions.

Personnel limits do not need to be posted in storage magazines, magazine areas, transfer points, and pier and wharf areas.

Explosive Limit Regulations

The maximum amount of ammunition or explosives permitted in a specific area is known as the *explosive limit*. Explosive limits may be expressed as the net weight of the explosives, the number of items, or the number of containers. The explosive limit of a building includes explosive items in vehicles or stored in the adjacent area outside the structure.

As the supervisor, you will be responsible for knowing and enforcing the explosive limits in your working area. If the permissible limit is exceeded, all operations must cease immediately. Only after the excess explosive quantity is removed, the operations may continue.

The determination of explosive limits depends on several factors. For magazines, the determining factors are the type of magazine, the hazards involved, and the quantity-distance relationship. For an operating building, the maximum explosive limit is determined by the operational directives that are subject to the applicable quantity-distance requirements in chapter 7 of NAVSEA OP 5.

Explosive limit placards must have lettering large enough to be read by persons with average vision as they enter the building.

Three-inch minimum-height letters must be used for signs in operating building areas including, but not limited to, inert preparation rooms, assembly rooms, finishing rooms, paint spray rooms, and rooms or confined areas of similar size used for similar functions.

One-inch minimum-height letters must be used for signs in service magazines, fuzing and defuzing cells, pyrotechnic mixing and pressing cells, and rooms of similar size used for similar functions.

Housekeeping Regulations

Good housekeeping (cleanliness and orderliness) is necessary for maintaining effective accident and fire prevention programs. All buildings and adjacent areas must be kept clean and orderly at all times. This is especially important in areas involving ammunition, explosives, and other hazardous materials because a potential danger is already present. As the supervisor, you will be responsible for ensuring that good housekeeping procedures are maintained constantly.

SMOKING.—Smoking is prohibited in any magazine, railcar, vehicle, or other conveyance that contains explosives, ammunition, or other hazardous material. Smoking is also prohibited where operations involving such material are in process. Smoking in vehicles that are passing through these areas of operations is not authorized. Designated smoking areas will be established by the commanding officer.

AISLES AND SAFETY EXITS.—The aisles in buildings that contain ammunition or explosives must be kept clear. Safety exits, such as doors and their outside passageways, ramps, and stairways, must not be blocked. All doors and locks must be kept in good working order. Doors must be fastened only with antipanic catches or approved quick-acting devices during operating hours, when work is scheduled or under way.

SAFETY EQUIPMENT.—Access to safety equipment must not be blocked. Such safety equipment consists of fire alarm stations, fire hydrants, fire extinguishers or hoses, protective-clothing lockers, safety showers, building and equipment electrical switches, thermometers, local fire bills, first-aid kit locations, and similar safety equipment.

TOOLS AND HANDLING EQUIPMENT.—When not in use, tools must not be left on floors, decks, platforms, scaffolds, stairs, ladders, ledges, rafters, or moving parts of machines or equipment. After use, tools must be collected and returned to the locations designated for their storage. Handling equipment must be neatly arranged and restored when not in use.

CLOTHING LOCKERS.—Clothing, not worn during working hours, must be kept only in approved clothing lockers in designated locations.

FLOORS.—Floors must be kept clean and free of stains such as those caused by exudation of explosives. They must be kept free of oil, grease, and other materials that tend to make them slippery. Floors must

not have cracks or crevices where explosives might lodge. Such defects must be repaired as soon as possible after discovery.

FIRE PREVENTION AND CONTROL

Fire is a great hazard to life and property, especially when ammunition and explosives are involved. Because explosives are very sensitive to heat and can react at temperatures lower than those that are required to ignite paper, wood, or fabrics, personnel involved in explosive operations must keep in mind that excessive heat must be prevented. It is the responsibility of all personnel concerned with ammunition and explosives to recognize and observe good practices for the prevention of fires and to understand procedures for fighting and controlling fires thoroughly that involve explosive materials. This subsection discusses fire prevention and control for mine shops and storage facilities.

Flame-Producing Devices

Flame-producing devices, such as matches and cigarette lighters, are not allowed in explosive areas. All personnel, involved in storage, handling, and production of ammunition and explosives, are not allowed to carry matches or lighters on their person. Only installed electric lighters shall be allowed in smoking areas, and these must be of a type that can be lighted only by a positive action, such as closing a switch or pressing a button.

Motor Vehicles

Motor vehicles and equipment that use internal combustion engines and that are used in the vicinity of explosives to transport ammunition, explosives, and other hazardous materials must be equipped with a spark- and flame-arresting device in the exhaust system.

Refueling

Motor vehicles that contain ammunition or explosives must not be refueled within magazines or explosive areas. With this in mind, you should ensure that this equipment is fueled before any operation to keep refueling to a minimum. Refueling of gasoline- or diesel-powered materials-handling equipment (MHE) is extremely hazardous when working with explosives or other hazardous materials. If you are involved in sustained operations and the MHE requires refueling,

some of the major points you must remember when refueling are as follows:

- Never refuel inside a building.
- Tow the equipment outside for refueling if the fuel supply is exhausted while in the building.
- Accomplish refueling at least 100 feet from the nearest explosive area and at least 20 feet from inert warehouses or buildings.
- Ensure that doors and windows of buildings through which vapors may enter are closed.
- Use the smallest size refueling unit available (500-gallon size or less).
- Ensure that a continuous grounding path is maintained from the tank being filled to the tank being emptied. The entire system must be electrically grounded.
- Ensure that the motors of both pieces of equipment are turned off unless the motor is required for pumping fuel.
- Run equipment motors for a sufficient time after refueling and recapping the tanks to ensure that a fire which might result from fuel vapors on the equipment occurs before the return to the operational area.
- Do not, in the event of a fuel spill, restart the motors of either piece of equipment until the fuel tank is capped and the spill is washed down with water or until the equipment is manually moved at least 50 feet from the spill.

NOTE

Never direct the contents of a CO² fire extinguisher at or into an open fuel tank in the event of a fire. High velocity streams of CO² when injected into the concentrated vapors of hydrocarbon fuels (such as JP, gasoline, diesel, etc.) can generate static electricity, despite a grounded fuel hose, and may ignite the fuel vapor and cause an explosion.

Vegetation

Vegetation, such as grass, leaves, undergrowth, and weeds, can become a serious fire hazard to structures and facilities. Vegetation can be ignited by sparks from motor vehicles, by careless use of flame- or spark-producing devices, or by lightning. Therefore, vegetation near explosive facilities must be

controlled. This can be accomplished by chemical weed killers or by cutting, plowing, or burning as necessary or appropriate under the circumstances. Grass and/or brush within 50 feet of explosives operating buildings, magazines, or open storage sites must be kept to the height not to exceed 18 inches.

Gasoline-powered grass cutters may be used on top of earth-covered magazines, but they should be kept at least 5 feet from ventilators and a safe distance from the door. The remaining 5 feet around the ventilator should be cut by hand-powered equipment.

Fire and Chemical Hazard Symbols

Fires that occur in explosives operating buildings and magazines pose various hazards to fire-fighting personnel. Some explosives detonate when exposed to heat or flames. Others may burn freely, produce poisonous fumes, or ignite when water is applied. To prevent a situation from becoming more hazardous than it might already be, understanding the fire and chemical hazard symbols associated with explosives or other hazardous materials is necessary.

FIRE SYMBOLS.—The fire symbols, as shown in figure 2-1, represent the four class-1 explosives divisions. The hazard decreases as the fire division symbol number increases. These symbols also designate those items that are hazardous to fire-fighting personnel and the burning or explosive characteristics of the stored material. Each of the four symbols has a distinctive shape, is colored orange, and has the class division number shown in the middle of the shape in black. The hazard and fire-fighting precautions for each symbol are summarized in table 4-1 of NAVSEA OP 5, volume 1.

CHEMICAL HAZARD SYMBOLS.—Chemical hazard symbols are used to identify operating buildings and storage facilities that contain pyrotechnics and chemical munitions or agents and other hazardous materials. They may be used by themselves or in conjunction with fire symbols, as appropriate. These symbols, as shown in figure 2-2, are used specifically for fire-fighting situations and are not necessarily applicable to normal operating conditions. The hazard each symbol represents and the fire-fighting precautions are summarized in table 4-2 of NAVSEA OP 5, volume 1.

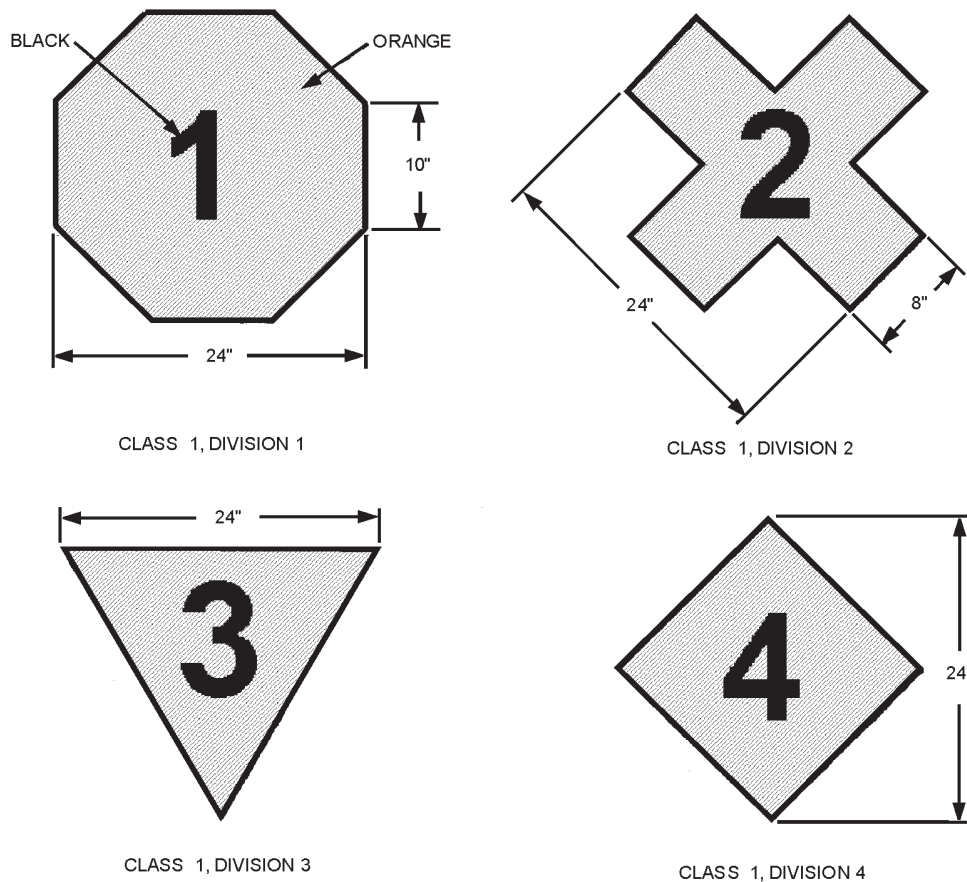

MNF02001

Figure 2-1.—Fire division symbols.

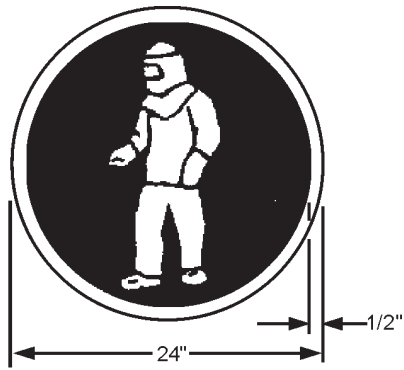

SYMBOL 1. WEAR FULL PROTECTIVE CLOTHING

Background is blue.
Figure and rim is:

Red for set 1 protective clothing

Yellow for set 2 protective clothing

White for set 3 protective clothing

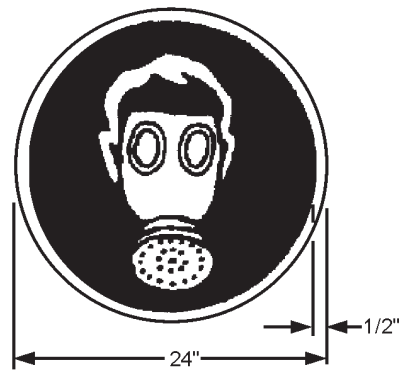

SYMBOL 2. WEAR BREATHING APPARATUS

Background is blue.
Figure and rim are white.

MNF02002

Figure 2-2.—Chemical hazard symbols.

FIRE-FIGHTING DIRECTION SYMBOLS .— Where pyrotechnics are involved, there are times when the use of water can intensify the fire, the hazard of explosion, and/or the spreading of the fire. The “apply no water” symbol, as shown in figure 2-3, is intended to inform fire-fighting personnel of the danger involved in containing the fire.

Posting Symbols

The symbol(s) that represent the most hazardous material present must be posted outside hazardous materials storage sites and operating buildings unless security considerations make it undesirable to identify the materials present at the location. In those cases, the posting of fire-fighting symbols on chemical sites will be at the discretion of the commanding officer.

A posted symbol must be situated so it is visible during daylight from a distance of at least 500 feet. If visibility is obstructed by vegetation curves in the road, and so forth, the symbol must be placed on the roadway at a distance of at least 500 feet.

One symbol posted on or near the door end of an igloo magazine or on the head wall of a box-type magazine is normally adequate. One or more symbols may be required on other buildings.

Where all material within a storage area is covered by one fire symbol, the symbol may be posted at the entry control point or the access roadway. Where different classes or divisions of explosives are stored in individual multi-cubicle bays or module cells, they may further be identified by posting the proper symbol on each bay or cell.

Placement of symbols must be coordinated with the fire department. Backing material for symbols should be the shape of the symbol decal and should be noncombustible.

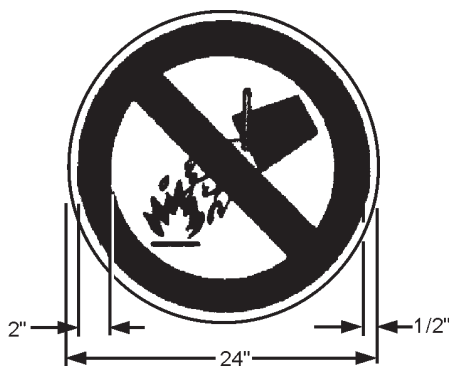

SYMBOL 3. APPLY NO WATER

Background is white, circle and diagonal are red, figures are black.

MNF02003

Figure 2-3.—Fire direction symbol.

Magazine Designator

All buildings and magazines of all types, including open storage sites, containing ammunition, explosives, or chemical or inert components normally associated with them, must be marked to provide rapid and positive identification of the facility.

The minimum identification consists of the building number; it must be at least 6 inches high. This number must be displayed on the facility or at the entrance of an open site.

Previously mandatory, but now optional, the magazine designator system consists of a three-group symbol made up of numbers and letters. This system is better described in appendix C of NAVSEA OP 5, volume 1. Stations may elect to continue using the optional facilities identification system if they so desire.

ELECTRICAL SAFEGUARDS

When personnel are working with explosives or other hazardous materials, consideration must be given to electrical safeguards. Primary, secondary, and static grounding systems are used to protect equipment and personnel from accidental ignition or combustion. This subsection discusses the grounding requirements for a MOMAG activity.

Power Ground System

The power ground system is used to keep hazardous electrical potentials from developing between equipments. The power ground prevents electrical shock to personnel and arcing between separate items, and it protects equipment from over voltage.

Instrumentation Ground System

The instrumentation ground system is used to provide error-free operation of sensitive electronic equipment. It minimizes spurious signals from entering the equipment from electrical distribution systems, lighting, motors, and other instrumentation that might be in the area. This system is normally connected to the secondary ground girdle.

Lightning Ground System

The lightning ground system is used to keep the entire activity at the same potential to prevent arcing between metal objects and to provide a low resistance path to a ground for lightning strikes.

Static Ground System

The static ground system eliminates electric discharges due to static buildup. It conducts the charges to the ground as fast as they are generated. Segments of static ground systems are conductive floors, ground grab bars, and conductive table tops. A static ground system may be connected to water pipes

or rods driven into the earth, but it must be interconnected to the secondary ground system.

Ordnance Ground System

The ordnance ground system is used to ensure that electric current does not flow between ordnance components when they come in contact or are mated. The ordnance ground system must be electrically separated from other ground systems and must be connected to the secondary ground girdle at a single point. The use of an ordnance buss connected to a single point is acceptable when several weapons are connected to the ground. Ordnance ground busses, static ground busses, and electrical ground busses must be clearly marked to keep personnel from misidentifying them.

Ground System Inspections

Ordnance ground systems must be visually inspected at least every 6 months to ensure that connections are secure and free from paint, corrosion, or foreign materials that may impair the efficiency of the system.

Ground System Test

The ordnance ground system must be tested for electrical resistance and continuity upon installation and at least every 24 months thereafter. The results of these tests must be maintained on file for at least five inspection cycles. It is recommended that test records be maintained for longer periods to provide a better database for trend analysis.

STORAGE OF AMMUNITION AND EXPLOSIVES

The proper storage of ammunition and explosives is essential in maintaining them in a ready-for-issue (RFI) condition. Magazines and inert facilities must be inspected and maintained to ensure that they are safe and clean and that they afford the protection necessary to the assets kept by your activity. This section discusses the storage regulations for ordnance and inert material.

Magazine Regulations

Ammunition and explosives must be stored only in magazines or other approved areas designed, designated, and isolated for the particular material.

The type and amount of material stored in a magazine or an area are dependent upon quantity-distance (Q-D) and compatibility requirements.

All permanent magazine assignments must be approved by the Naval Sea Systems Command (NAVSEASYS COM). Occasionally, under emergency situations, it may be necessary to store ammunition or explosives temporarily in a structure not constructed as a magazine. Under these situations, the structure should, in all respects, provide adequate protection for the contents and adjacent areas. The structure must also provide adequate protection against moisture and dampness, have adequate ventilation comply with Q-D requirements, and be equipped with approved lightning protection if required. All applicable conditions of magazine storage and security requirements commensurate with the contents of the magazine must be met.

Magazine Operations

Operations, involving ammunition and explosives in magazines and magazine areas, are limited to specific types of work, both permitted and prohibited operations. You must be familiar with the operation and type of work you can perform in the magazine before you start the job. The following subsections are excerpts from volume 1 of NAVSEA OP 5 and are not all inclusive.

PERMITTED OPERATIONS.—The following operations are permitted in and around magazines:

- Palletizing for storage or shipment. Not more than four people and two pallet loads may be involved.
- Opening containerized units for visual inspection without removing items from containers.
- Replacing damaged or loose strapping on boxed ammunition.
- Removing bomb nose and tail plugs by hand for visual inspection of cavities and liners.
- Removing minor rust and corrosion, touching up paint, and stenciling non-mass detonating items, but only on loading docks, empty railcars, or motor vehicles outside magazines and away from magazine doors.

PROHIBITED OPERATIONS.—The following operations are prohibited inside magazines:

- Fuzing or unfuzing operations

- Boosting or deboosting bombs
- Soldering or other heat-producing operations
- Painting, repainting, stenciling, or restenciling
- Performing electrical checks or tests on weapons

Magazine Exits

At least one door must be open when one or more people are working in a magazine. The exit route must not be blocked. Magazines with self-closing latches must be secured so that they will not swing shut and trap personnel inside.

Motor Vehicles and Railcars

When motor vehicles or railcars are used to transport ammunition or explosives to and from the magazines, they must be unloaded as quickly as practicable.

Red Flag

A red (Bravo) flag must be prominently displayed at the entrance to each magazine area where personnel are working. At the discretion of the commanding officer, a Bravo flag may also be displayed on each magazine where personnel are working.

Explosives Operating and Assembly Buildings

Hazardous materials should not be allowed to accumulate within an operating or assembly building except for the minimum quantities necessary to maintain operations. However, ammunition and explosives that are part of the work in process within the building may be stored overnight in operating and assembly buildings provided the following requirements are strictly observed:

- Approved explosive limits are not exceeded.
- Compatibility requirements are met.
- Explosives, mines, all-up rounds, and so forth, are not exposed. Containers of bulk explosives or propellants must be properly and securely covered.
- The building must be equipped with an automatic sprinkler system. However, a waiver to this requirement may be obtained from the CNO.
- The building must be specifically included in the schedule of the security patrol.

- The fire department must be made aware of the content of the building.
- A red (Bravo) flag must be displayed to indicate the presence of ammunition or explosives.

If the operation in a building is to be inactive for a period in excess of 108 hours, all ammunition and explosives must be removed to magazines. Normally, supplies, exceeding approximately an 8-hour work requirement, must be kept in a ready-service magazine located at an intraline distance from the operating building.

Magazine, Magazine Area, and Storage Inspections

All areas used for long- or short-term storage or holding ammunition explosives and/or other hazardous materials must be periodically inspected. At a minimum, magazines must be inspected before initial use, before reuse after being empty, and periodically while in use to ensure that the facilities are capable of safely storing ammunition, explosives, and/or other hazardous materials. The inspection must include an examination of the facility or location, the surrounding area, and the material being stored. The inspection must address, but not be limited to, the following factors:

1. Housekeeping
2. Fire hazards
3. Content compatibility
4. Net explosive weight
5. Grounding system and lightning protection
6. Security systems
7. Physical condition and suitability of the facility, including roads, rail service, and power lines
8. Firebreaks and fire protective equipment
9. Environmental control
10. Content identification, arrangement, segregation, and condition
11. Posting of fire, chemical hazard and safety information, and explosive limits
12. First-aid equipment
13. Alarm systems
14. Unnecessary combustible material

15. Abnormal odors, thermometer condition, and log (if installed)
16. Evidence of tampering, forced entry, or sabotage
17. Current magazine standard operating procedure (SOP)

A log must be maintained to document all deficiencies and corrective actions taken. Mandatory log entries include the date of inspection, the inspection SOP used, the deficiencies detected, and the deficiencies corrected. All entries must be signed.

QUANTITY-DISTANCE REQUIREMENTS

The relationship between the quantity of hazardous material allowed in an area and the separation (safety) distance between such areas is known as *quantity-distance* (Q-D). Q-D requirements are designated to protect personnel from serious injury or death and all adjacent property from destruction by fires or explosions.

As a Mineman, you normally will not determine the Q-D requirements for an operating building or a storage area. However, you must be aware of the necessity for such requirements and their principles and applications.

BASIC Q-D PRINCIPLES

The principle considerations that form the basis for Q-D requirements are the amount and type of material involved, the segregation of material, the separation (safety) distance, and the material hazard classification. Volume 1 of NAVSEA OP 5 provides applicable Q-D tables.

Quantity of Material

The potential hazard area, surrounding the accumulation of explosives, increases as the quantity of explosives increases. Therefore, it is desirable to minimize the quantities of explosives at any one location. Limits have been established, in most cases, for the maximum amount of explosives permitted in any one pile and in any one magazine, and the distances that such piles or magazines are to be separated. Whenever practicable, the specified distances should be exceeded to afford greater safety.

Type of Material

The potential dangers, involved in the storage of ammunition and explosives, are not measured solely by the quantity of explosives stored but also by the kind of explosives. Ammunition and explosives, used by the Navy, are classified into certain broad subdivisions, or groups, for storage purposes. The materials within each group present the same general type of hazard and are, therefore, stored in the same general manner.

Segregation of Material

Some explosives are more hazardous than others, and some are potentially more hazardous when stored with others. Therefore, the segregation of certain types of ammunition and explosives is imperative. Magazines of different sizes and designs are used, depending on the characteristic of the material to be stored.

Separation Distance

The distance, separating the location of one location of explosives from another location of explosives, and from inhabited buildings or facilities, determines the permissible amount of explosives at any location. Separation distances are measured along a straight line from the outside of the nearest wall of the structure containing explosives, or the nearest wall of the controlling subdivision when the structure is subdivided. Subdivisions are used within a structure to prevent mass detonation of material within the structure.

Hazard Classification

The hazard classification system is based on a system established for international use by the United Nations Organization (UNO). The UNO system consists of nine classes of dangerous material. The nine classes and the types of hazardous materials involved are shown in table 7-1 of NAVSEA OP 5, volume 1.

You will deal primarily with hazard class-1 material (ammunition and explosives, Department of Transportation [DOT] classes A, B, and C blasting agents). The ammunition and explosives hazard class 1 is further subdivided into six divisions. These divisions are based on the characteristics and predominance of the associated hazards and on the potential for causing

personnel casualties or property damage. The divisions and types of hazards expected are as follows:

1. Division Designator 1—Mass detonating
2. Division Designator 2—Non-mass detonating, fragment producing
3. Division Designator 3—Mass fire
4. Division Designator 4—Moderate fire, no blast
5. Division Designator 5—Very insensitive
6. Division Designator 6—Extremely insensitive

STORAGE COMPATIBILITY

The assignment of class-1 ammunition and explosives into six divisions does not necessarily mean that the different items in a division may be stored or transported together. Compatibility groups determine storage and transportation compatibility for rail and motor modes, while the class and division designators determine segregation requirements for carriage by vessels. Explosive articles that differ in minor respects may be assigned to different divisions if their predominate hazards differ.

Storage Compatibility Groups

A compatibility group accompanies the hazard class to complete the hazard classification designation. Ammunition and explosives are assigned to a compatibility group when they can be stored and transported together without significantly increasing either the probability of an accident or, for a given quantity, the magnitude of the effects of such an accident. Ammunition and explosives are assigned to 1 of 13 compatibility groups; mines and their explosive-loaded components fall into 6 of these groups.

Storage Compatibility Tables

All ammunition, explosives, and related hazardous materials must be stored by compatibility group. Different types of ammunition and explosives, by item and division, may be mixed in storage if they are compatible and, as required, are authorized for mixed storage by the NAVSEASYSCOM. Criteria for permissible storage of different kinds of explosives is given in NAVSEA OP 5, volume 1. Mixing of compatibility groups in storage is permitted according to *Transportation and Storage Data for Ammunition, Explosives and Related Hazardous Materials*,

NAVSEA SW020-AC-SAF-010, providing the material is in its proper packaging configuration.

EXEMPTIONS AND WAIVERS

Exemptions and waivers are written authorizations that allow specific deviations from mandatory requirements. The difference between the two is the time period for which the deviation is granted. Normally, an exemption is granted for a period of 5 years or less, whereas a waiver is granted for a period of 2 years or less.

The procedures for requesting exemptions and waivers concerning ammunition and explosive requirements are contained in OPNAVINST 8020.14. All such requests are submitted to the CNO, via the chain of command and the Commander, Naval Sea Systems Command (COMNAVSEASYS COM).

Activities, granted exemptions and waivers, must periodically review the necessity for the deviations. Existing exemptions and waivers must be revalidated every 5 and 2 years, respectively, according to OPNAVINST 8020.14 and NAVSEA OP 5, volume 1. If an existing exemption or waiver is no longer required, the CNO must be informed so the exemption or waiver can be canceled.

HANDLING EQUIPMENT

Accidents that occur during the handling of hazardous material can cause destruction of essential material, injuries, and sometimes death. Many accidents are caused by lack of knowledge, by not using the proper equipment for the job, and by careless operations. You must ensure that when you are involved in handling ammunition and explosives, you have a thorough understanding of the operation and of the hazards involved in the use of the equipment. This section discusses industrial materials-handling equipment, ordnance-handling equipment, and dollies.

INDUSTRIAL MATERIALS-HANDLING EQUIPMENT

Industrial materials-handling equipment (MHE) for use in ammunition- and explosives-handling operations includes forklift trucks, pallet trucks, platform trucks, crane trucks, warehouse tractors, and warehouse trailers. This equipment is classified by types based on their use. The following subsections

discuss the types, selection and use, operation and maintenance, and repair of MHE.

Equipment Types

Industrial MHE, approved for specific uses, is assigned a standard alphabetical type designation that identifies its fire and explosion safety features and its power source. These designators appear on the sides and the rear of each piece of MHE. The type designations are as follows:

- Type D—diesel powered; minimum acceptable safeguards against fire hazards.
- Type DS—diesel powered; additional safeguards to exhaust, fuel, and electrical systems.
- Type EE—electrically powered; safeguards against igniting fire or explosion; electric motor and all other electrical equipment are completely enclosed. Generally referred to as *spark enclosed*.
- Type EX for Class I—electrically powered; all electrical fixtures and equipment constructed and assembled so that the truck may be used in certain atmospheres that contain flammable vapors. Generally referred to as *explosion proof*.
- Type EX for Class II—electrically powered; all electrical fixtures and equipment constructed and assembled so that the truck may be used in atmospheres that contain combustible dust. Generally referred to as *ignition proof*.
- Type G—gasoline powered; minimum acceptable safeguards against igniting fire or explosion.
- Type GS—gasoline powered; additional safeguards to exhaust, fuel, and electrical systems over type G.
- Type H—hand powered.
- Type HS—hand powered; electrically conductive nonsparking wheels or ground strap.

Always select the proper equipment for the operation. Generally, the EE- and EX-type equipments are used in operations that involve handling ammunition and explosives inside buildings. The DS- and GS-type equipments are normally used in open areas or areas with adequate forced ventilation.

Equipment Markings

MHE that is used for handling ammunition and explosives is painted solid yellow, with the exception of explosion-proof trucks and tractors. These are painted yellow with 6-inch blue diagonal stripes at 45 degrees across each side and on the rear. Also, the designation (EE, DS, etc.) is painted in 4-inch black block letters on both sides and at the rear of all equipment. The safe working load (SW), the weight test date, and the vehicle weight of the equipment must be clearly printed on an appropriate space that is in view of the operator.

Operator Safety

Personnel who operate MHE must observe the following safety precautions:

- Check the condition of the MHE before starting periodically during use and after securing for the day.
- Only qualified personnel who are properly trained and licensed are to operate MHE.
- When the engine is shut off, set the brake, and lower the forks to the deck when leaving the equipment unattended.
- Do not allow anyone to stand or walk under any elevated portion of the equipment.
- Keep arms and legs inside the running lines of the equipment.
- Do not put arms or legs between the uprights of the mast.
- Do not use MHE for opening or closing doors.
- Do not remove overhead guards without permission of the safety officer.
- Always ensure that the load is balanced and secured and does not exceed the capacity of the forklift.

NOTE

This is not a complete listing of safety regulations. Ensure that you are familiar with the contents of volume 1 of NAVSEA OP 5, and *Handling Ammunition, and Explosives with Industrial Materials Handling Equipment (MHE)*, NAVSEA SW023-AH-WHM-010.

Equipment Testing

Periodic testing and frequent inspections of MHE is essential if equipment reliability and safety are to be maintained. Frequency of tests for shore activities must not exceed 500 operational hours of use or 12 months, whichever occurs first. These tests must also be performed before placing the equipment into service or whenever components are changed or repaired. A log must be maintained by the testing activity for each piece of equipment tested, indicating date, place, by whom, and disposition of each deficiency. This log must remain with the equipment if it is assigned to another activity. For further information on testing of MHE, refer to NAVSEA SW023-AH-WHM-010.

Explosives Drivers

Personnel, involved in transporting hazardous materials, must meet certain qualifications to be certified as an explosives driver. These qualifications are as follows:

- The driver must be at least 18 years of age for on-station movement and 21 years of age for off-station movement.
- The driver must have a valid state driver's license. It need not necessarily have been issued by the state where the activity is located.
- The driver must have a physical every 2 years and have a medical examiner's certificate.
- The driver must have an explosives driver identification card (Standard Form 46), which must be noted with *Explosives Driver*.
- All explosives drivers must receive at least 12 hours of instruction and training in driving trucks and tractors, handling and transporting hazardous materials, regulations and procedures pertaining to transporting hazardous materials, properly using fire extinguishers, and completing and filing required reports.

ORDNANCE-HANDLING EQUIPMENT

The handling of ammunition, explosives, and other hazardous materials should be kept to a minimum. However, when handling is necessary, use properly tested and tagged equipment designed for the task.

Except as otherwise indicated, portable ordnance-handling equipment used ashore must be tested annually at 40 percent of the design load of the equipment. This testing schedule must be followed for all ordnance-lifting equipment, unless specifically exempted by higher authority.

Equipment that has satisfactorily passed the periodic load test requirements must have the name of the testing facility, the date tested, and the safe working load (SWL) stenciled in legible, contrasting colored paint on a conspicuous surface, or this information may be stamped or etched on a tag that is securely attached to the equipment. See figure 2-4. New ordnance-handling equipment, received in original packaging if an inspection shows that the equipment is free of defects, may have the test date changed to the current date without retest. A record of each periodic test must be maintained by the facility performing the periodic test.

For further information regarding the testing of ordnance-handling equipment, refer to *Periodic Testing Arrangements for Ordnance Handling Equipment*, NAVSEA SG420-AP-MMA-010.

Lifting equipment, used for handling ammunition and explosives, specifically mines, includes adapters, booms, hoists, lifting attachments, and slings. The following subsections discuss various types of handling equipment and their uses.

Slings

In the assembly areas, slings are used mainly for crating, uncrating, and marrying various sections of the mines. They are used for shipboard loading and off-loading of mines at dockside and for transferring the mines between ships at sea. Slings can be classified into the following two groups:

Nonmetallic nylon slings form a choker hitch around the body of the mine or the mine component.

Multiple-leg, wire-rope slings are shackled or safety-hooked to lugs, rings, eyebolts, or lifting eyes. They are either an integral part of the load or are attached temporarily during handling.

Before you use any ordnance-handling equipment, you should verify that it has been tested and that the test date is current. Inspect the equipment for evidence of wear, such as frayed threads, broken stitches, cuts, damaged cables, loose fasteners, missing safety keepers, bent hooks, and so forth. If any such damage is noted, remove the equipment from service.

MK 95 MOD 0 TORPEDO SLING.—Although its nomenclature indicates it is used with torpedoes, this sling is also used with other cylindrically shaped weapons that are 21 inches in diameter and within its rated lifting capacity of 5,000 pounds. Fabricated of nylon webbing with a loop that is reinforced with a leather pad at each end, the sling is used for loading the Mk 67 mine aboard submarines. As shown in figure 2-5, the sling is wound twice around the mine with one loop inserted through the other to form a double-wrap choker hitch. The loops are reinforced with leather wear pads, and both sides of the body have nylon wear straps so that either side may bear directly against the mine without chafing.

MK 99 MOD 0 WEAPONS-HANDLING SLING.—The Mk 99 Mod 0 weapons-handling sling is used at dockside and aboard ammunition ships for loading combatant ships with crated mines and palletized unit loads of mines. This sling, as shown in figure 2-6, consists of four swiveled safety hooks, each attached to a flexible, galvanized 1/2-inch, wire-rope leg. The four legs are joined to a 5 1/2-inch lifting ring that is compatible with standard cargo lifting gear used at dockside or aboard ammunition ships. Its rated lifting capacity is 6,000 pounds. The sling is used for lifting one crated Mk 56 mine.

MK 101 MOD 0 MINE SLING.—Except for its shorter length, the Mk 101 Mod 0 mine sling, as shown in figure 2-7, is similar to the Mk 95 Mod 0 torpedo

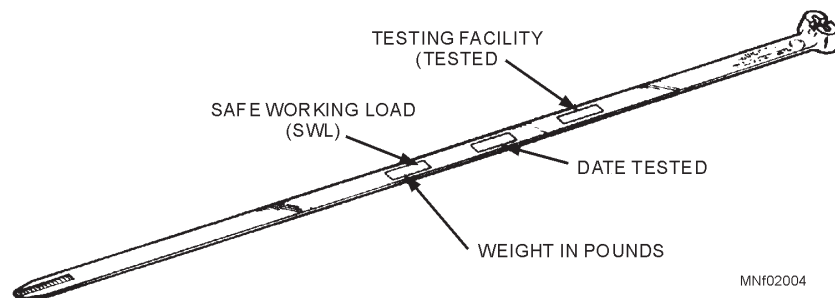
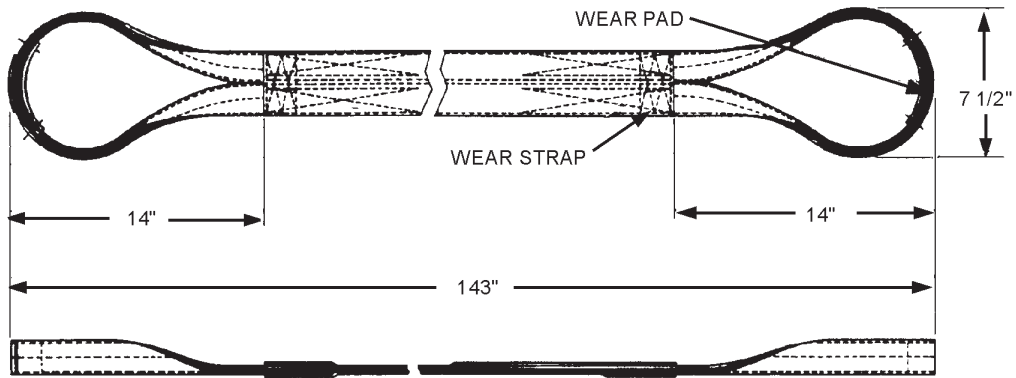
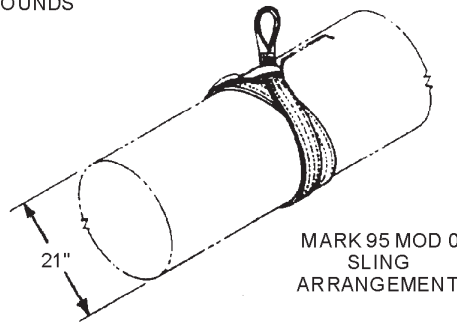

Figure 2-4.—Weight test inspection tag.



CAPACITY 5000 POUNDS



MNF02005

Figure 2-5.—Mk 95 Mod 0 torpedo sling.

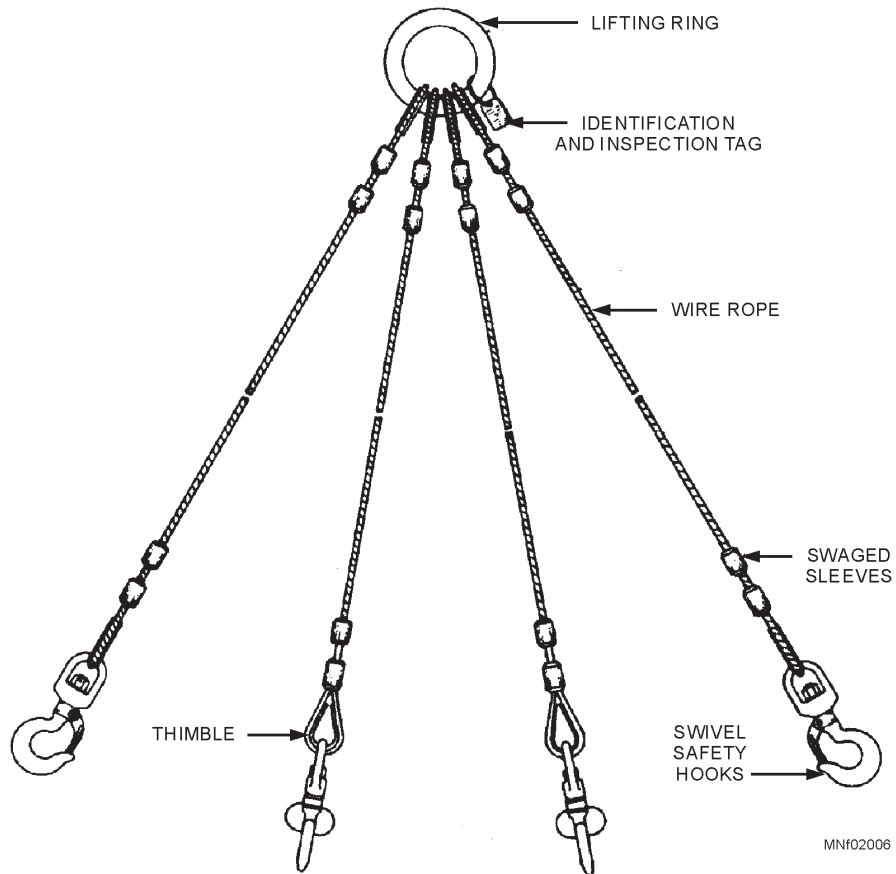

MNF02006

Figure 2-6.—Mk 99 Mod 0 weapons-handling sling.

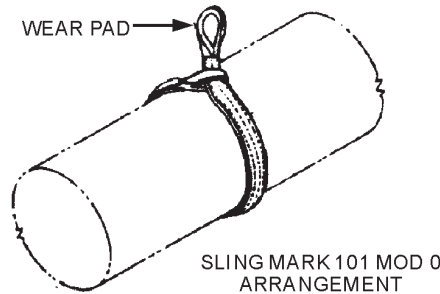
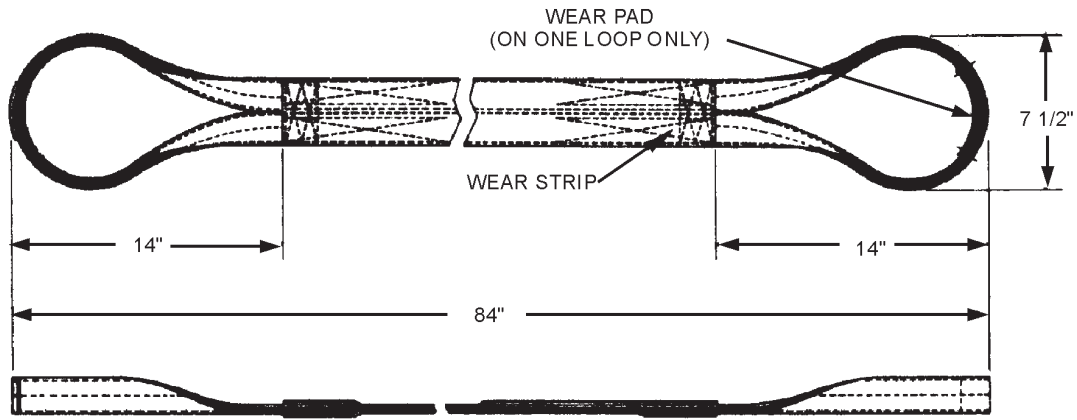

MNF02007

Figure 2-7.—Mk 101 Mod 0 mine sling.

sling. It is used for lifting the Mk 56 mine in and out of its shipping crate and for hoisting operations when marrying or disassembling sections of the Mk 56 mine. The sling is made of nylon webbing and has a loop at each end. One loop is reinforced with a leather wear pad and should always interface with the hoisting equipment. The sling is wrapped once around the body of the mine to form a single-wrap choker hitch so that the reinforced loop is positioned to engage the hoisting equipment. This lifting capacity of the sling is 5,000 pounds.

MK 111 MOD 0 SLING.—The Mk 111 Mod 0 sling is constructed in the same manner and of the same materials as the Mk 95 and Mk 101 slings. As shown in figure 2-8, it is a single-wrap sling used for hoisting operations when marrying or disassembling sections of the Mk 67 mine. The lifting capacity of the sling is 5,000 pounds.

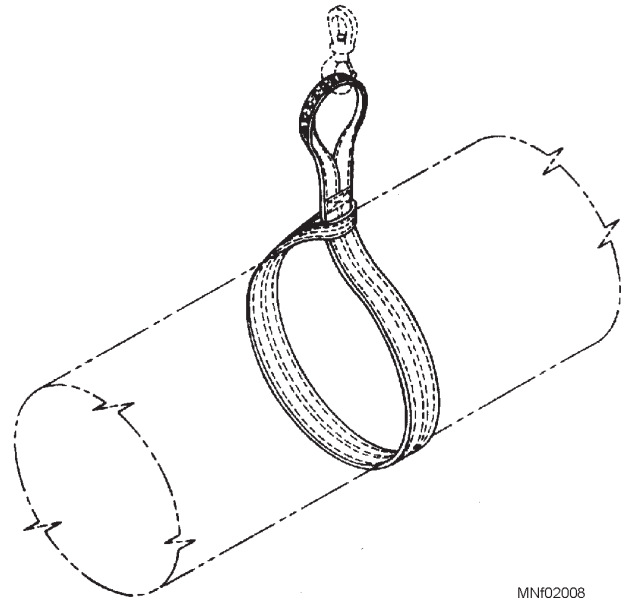

MNF02008

Figure 2-8.—Mk 111 Mod 0 sling.

MK 115 MOD 0 WEAPONS-HANDLING SLING.—The Mk 115 Mod 0 weapons-handling sling consists of two 1/2-inch wire ropes, 18 inches long, joined at one end by a 5 1/2-inch steel lifting ring. The other ends of the legs are terminated with shackles. Safety hooks are supplied with the sling. The Mk 115 Mod 0 sling, as shown in figure 2-9, is used for the general handling of the Mk 56 mine anchor and for hoisting operations when marrying or disassembling

the anchor section and the mechanism section of the Mk 56 mine. The lifting capacity of the sling is 2,500 pounds.

Lifting Devices

In conjunction with hoists, lifting devices are used for handling mines and mine components in shop areas

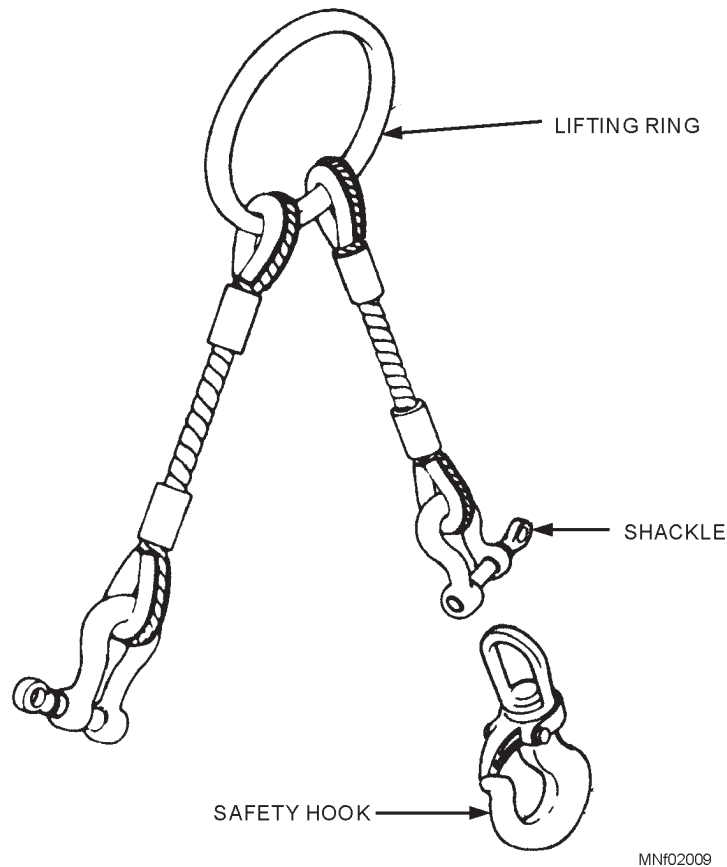

Figure 2-9.—Mk 115 Mod 0 weapons-handling sling.

and magazines, both ashore and on board ship. Some examples of devices that make up this group of mine-handling equipment are carriers, lifting plates, lifting rings, and eyebolts.

MK 49 MOD 1 WEAPON CARRIER.—The Mk 49 Mod 1 weapon carrier is used as a lifting attachment

for hoisting mines with suspension lugs spaced 14 inches apart. The steel-plated carrier, as shown in figure 2-10, has a lifting capacity of 2,500 pounds and has four hoisting points and two attaching studs. A fixed stud is at one end of the strongback, and a pivoting stud is at the other end. They are locked in place on the mine by a quick-release pin.

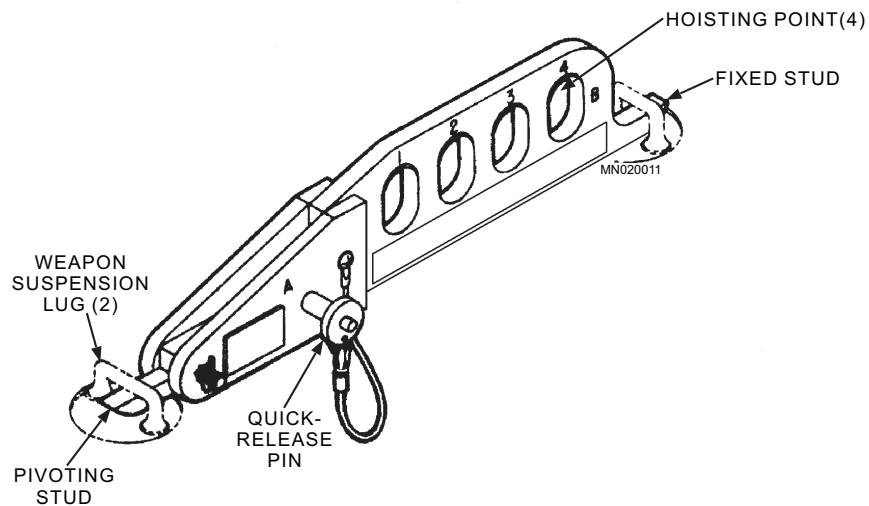

Figure 2-10.—Mk 49 Mod 1 weapon carrier.

MK 55 MOD 1 WEAPON CARRIER.—The Mk 55 Mod 1 weapon carrier is used to handle mines with suspension lugs spaced 30 inches apart. The carrier, as shown in figure 2-11, has a lifting capacity of 3,000 pounds. It consists of two aluminum side plates and two stationary steel hooks; one hook has a spring-loaded steel safety latch. A quick-release pin secures the latch in the locked position. A lifting eye is centered on the top of the carrier.

DOLLIES

Dollies are used for moving mines and mine components (either crated or uncrated) for short distances in the mine shop assembly areas. They are also used as stands or stationary fixtures during assembly, test, inspection, repair, or replacement of

parts. For example, the placement of a mine section directly under a hoist hook for subsequent marriage to other sections, or the positioning of mine sections for installation of smaller components, is usually accomplished with dollies. In certain instances, dollies are also used for marrying major mine components.

Mk 11 Weapons Dolly

The Mk 11 weapons dolly is used for moving major mine sections to the hoists in the shop where marriage to other sections is accomplished. It is also used for the assembly, handling, maintenance, and testing of Mk 56 and Mk 65 service mines and most exercise and training assets.

The dolly, as shown in figure 2-12, is constructed of welded tubular steel and has a 3,000-pound capacity.

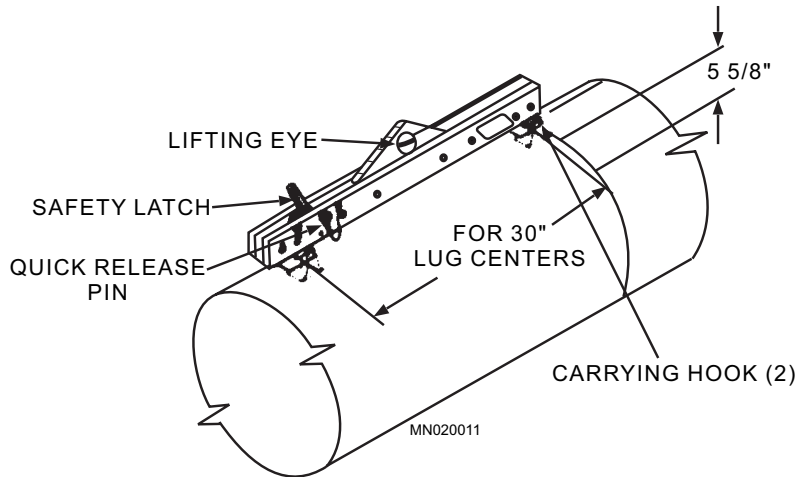

Figure 2-11.—Mk 55 Mod 1 weapon carrier.

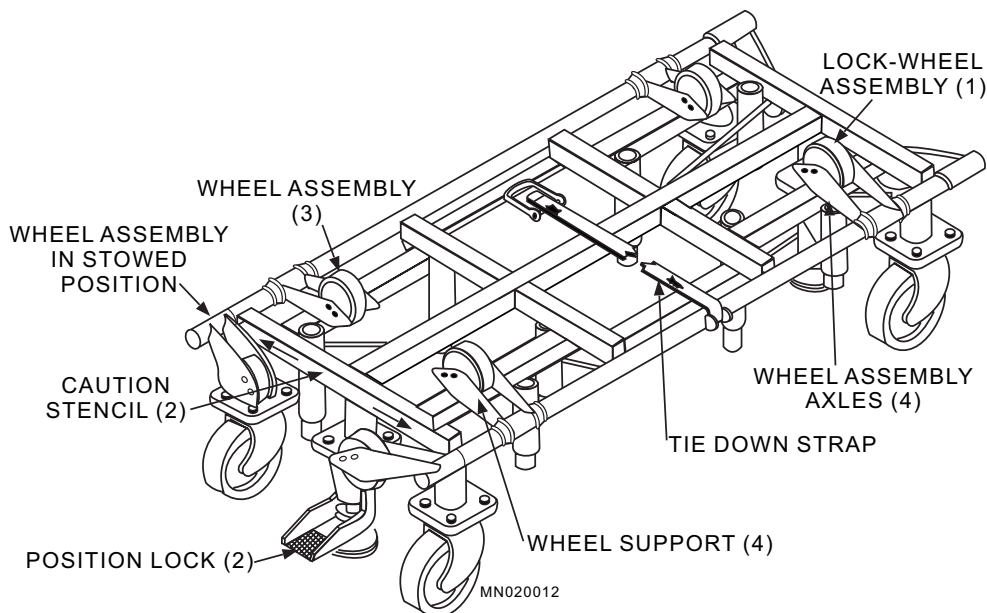

Figure 2-12.—Mk 11 Mod 1 weapons dolly.

Its caster wheels allow it to be maneuvered in any direction. Adjustable wheel assemblies provide bearing surfaces for cylindrical weapons from 9 to 22 1/2 inches in diameter. When unlocked, the wheel assemblies permit rotation of the loads to positions convenient for installing smaller components. Load rotation is restricted by locking one of the wheel assemblies (lock-wheel assembly) with a locking screw that seats in any one of the index holes in the associated wheel support.

The improved Mk 11 Mod 1 weapons dolly has a welded gusset on each wheel support to prevent spreading. It also has support beams that run the entire length of the dolly. This eliminates the tool tray found on the Mk 11 Mod 0 dolly, but gives better wheel support handling of explosive sections of Mk 56 and Mk 67 for the full length of the dolly. The Mk 11 Mod 0 dolly is obsolescent.

The Mk 11 weapons dolly has an instruction plate that shows the proper wheel axle positions for various diameter mines. Position locks under each end of the dolly, anchor it to the deck, and permit it to be used as a stationary work platform. A tie-down strap secures the load. When handling crated mines, store the wheel assemblies below the bed at each end of the dolly.

Mk 21 Mod 0 Dolly

The Mk 21 Mod 0 dolly (formerly called the universal dolly) is ideal for handling cylindrical mine sections of various lengths and diameters. It is used for the general mines, as well as the various other sections of the Mk 67 mine. Its height is adjustable, between 18 1/2 inches and 28 inches, and its length can also be adjusted, between 10 1/2 inches and 46 1/2 inches, depending on the section supported. The Mk 21 dolly, as shown in figure 2-13, is constructed of tubular aluminum and has a capacity of 1,600 pounds. It is equipped with lockable casters and clips that hold the accessory extension tubes when they are not in use.

AERO 51B MUNITIONS TRAILER

The Aero 51B munitions trailer is a flat-bed trailer used for intrabase transportation of small quantities of mines and destructors between magazines, assembly shops, staging areas, airfields, and dockside locations, depending on the distance. The trailer, as shown in figure 2-14, has an automotive-type chassis with two axles and four single wheels. It is equipped with hydraulic-surge brakes, as well as mechanical parking brakes. A tow bar and a cable harness are provided for connection to any of a variety of tractors and trucks. Accessory items (such as chocks, tie-down straps, and

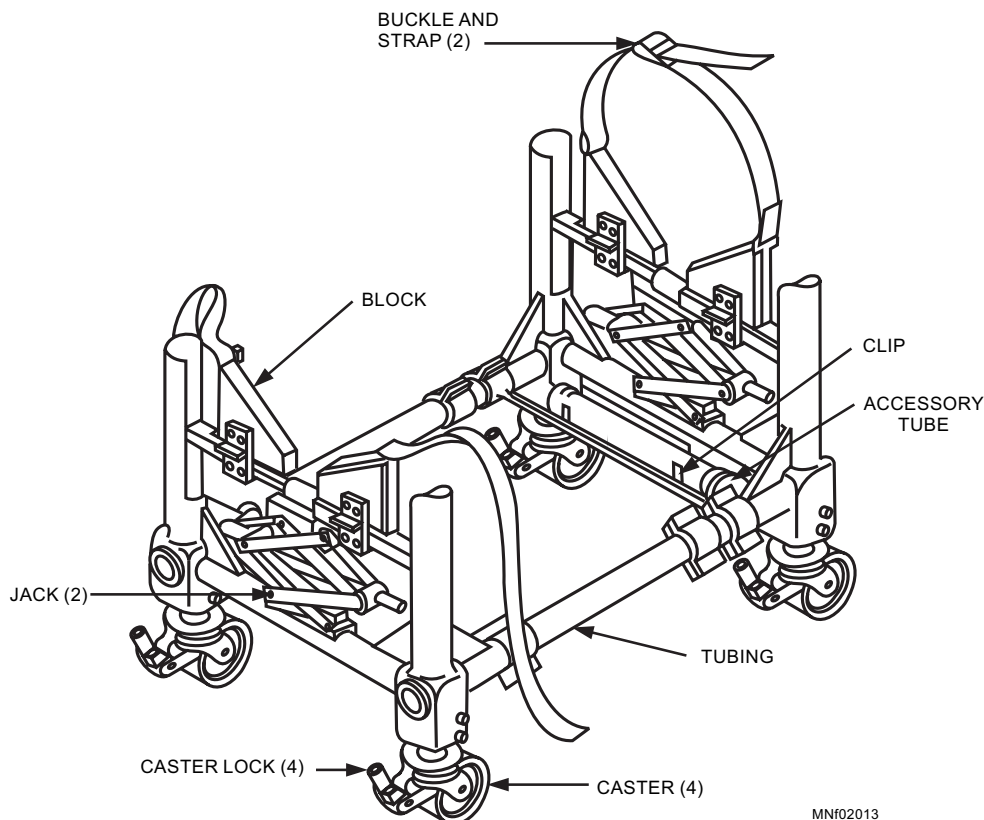

MNF02013

Figure 2-13.—Mk 21 Mod 0 dolly.

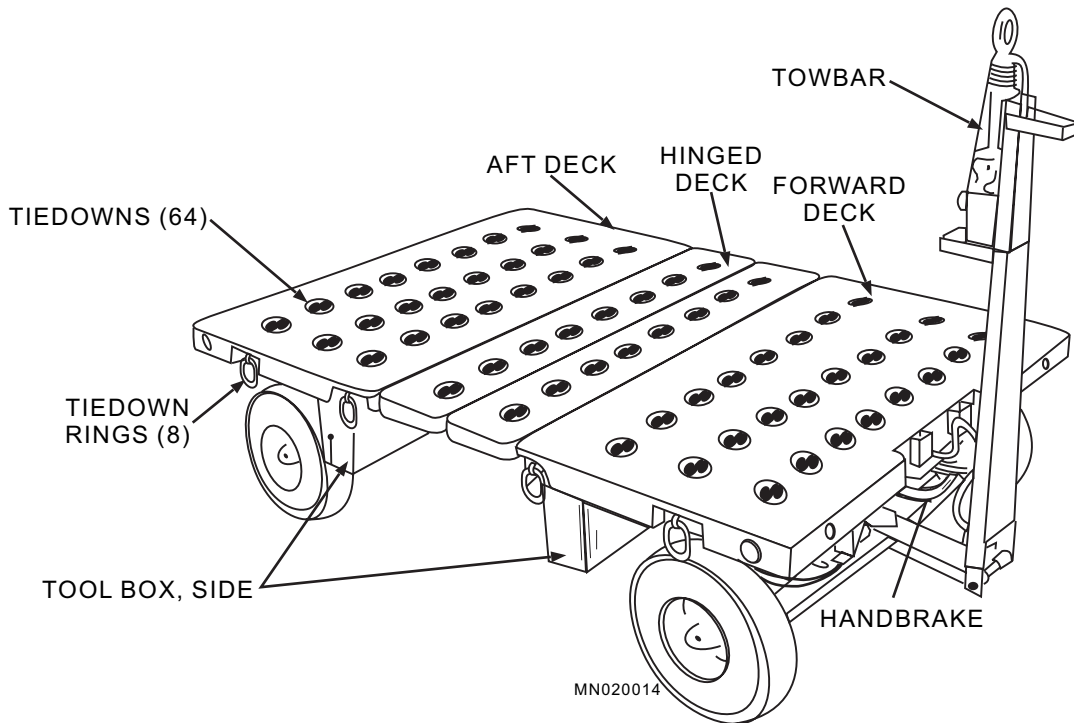

Figure 2-14.—Aero 51B munitions trailer.

an interconnecting electrical harness) are stored in toolboxes mounted underneath the forward and aft sections of the bed. The center section of the bed is hinged and can be opened to provide a hatchway across the full width of the trailer. Hinged bed panels have double rails with holes at intervals to provide a mounting base for chocks and roller adapters.

The Aero 51B trailer has a capacity of 8,500 pounds and can be towed in trains of not more than three. Maximum towing speed of one trailer is 20 miles per hour (mph); however, if more than one trailer is being towed, the maximum speed is 10 mph.

GANTRY A-FRAME

The gantry A-frame is used for suspending one portion of a mine when marrying to another. It has two trolleys and two air or chain hoists suspended from a 15-foot I-beam, supported at each end by a steel A-frame. The working height of the gantry is adjustable between approximate heights from 10 to 17 feet by the operation of four independent spring-loaded bolts and jacks attached to the A-frame legs. The spring-loaded bolts seat into located holes in the telescoping legs of the A-frame.

Adjusting the height of the A-frame requires first that each jack be wound tautly to assure support of each leg. Then the four spring-loaded bolts are pulled out of their respective locating holes and held tensioned by

the insertion of ball-lock pins. The jacks are operated simultaneously to maintain the necessary length of the legs of the A-frame at any given time, thereby ensuring maximum gantry stability. When the A-frame is within approximately 4 inches of its desired height, the ball-lock pins are removed, allowing the spring-loaded bolts to press against the telescoping legs. The spring-loaded bolts snap into their respective locating holes when the desired height is reached.

Removal of a quick-release pin from the sliding tube that forms the base of the A-frame permits the frame to spread to any one of four positions. Reinsertion of the quick-release pin maintains the tube in a fixed position. The four 8-inch casters permit easy maneuvering of the entire structure either indoors or outdoors. The hoists can be positioned anywhere along the desired height of the I-beam. The trolley wheels travel on its bottom flange.

The safe working load of the gantry A-frame, as shown in figure 2-15, is either 3,000 or 4,000 pounds, depending on the hoists used. However, the 4,000-pound capacity must NEVER be exceeded.

BOMB ASSEMBLY STAND

The bomb assembly stand provides a working height platform in magazine or bomb assembly areas upon which bombs of various weights and sizes can be assembled. The stand, as shown in figure 2-16, consists of three table assemblies and four tray assemblies. The

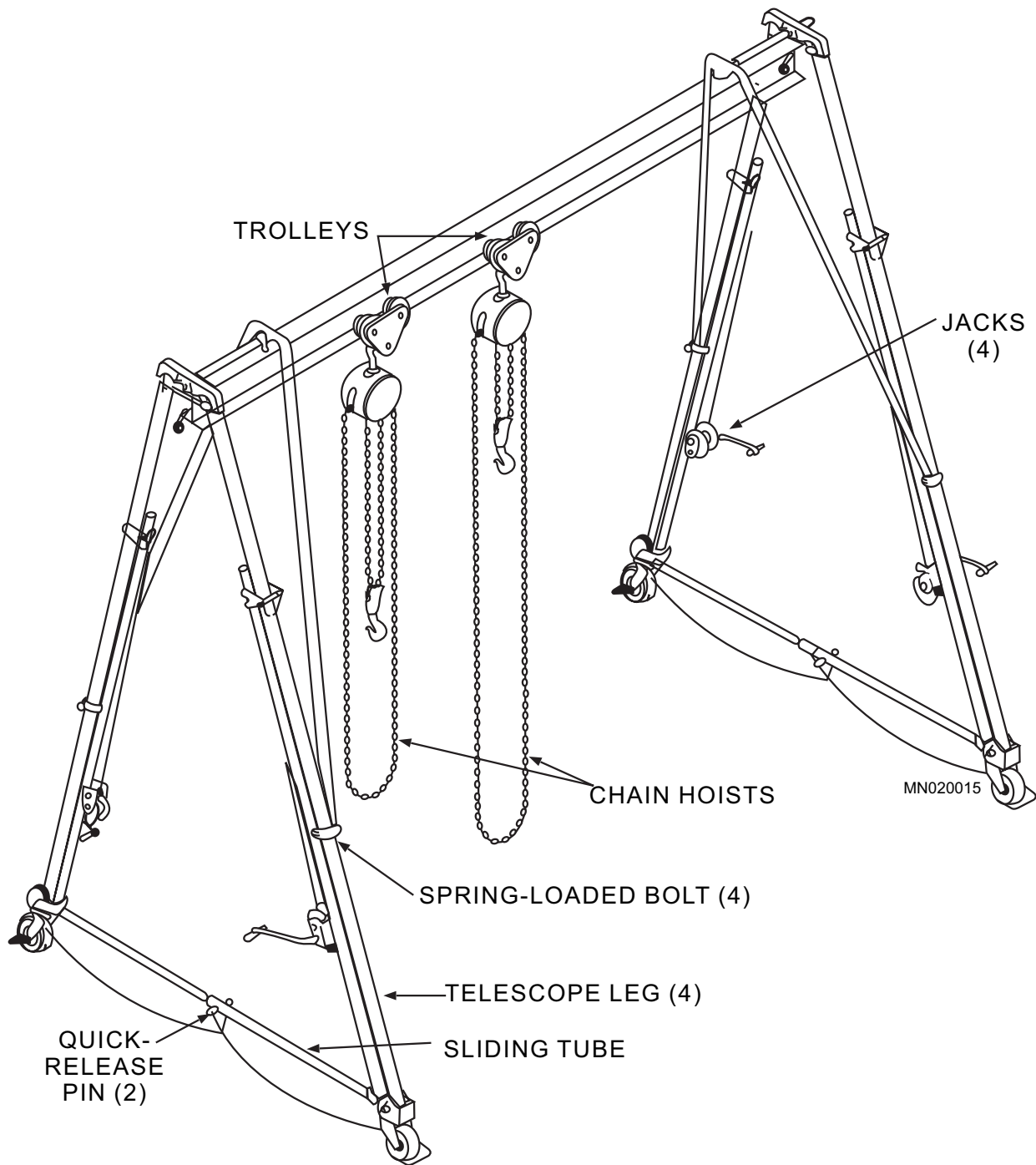

Figure 2-15.—Gantry A-frame.

table assemblies are structured frame weldments with folding leg weldments at each end that, after erection, are secured together with the center table assembly to form one complete table assembly. The top of the table assembly has two rows of industrial-type rollers and stops at the ends of the completely assembled table. The trays are also structural frame weldments with rollers on top that support and permit a 360-degree rotation of any bomb being assembled.

Maintenance and testing of the stand must be according to *Periodic Maintenance Requirements*

Manual, NAVSEA AG-220BO-MRC-010. In addition to these requirements, the stand must be tested anytime it is reassembled.

RECOMMENDED READING LIST

NOTE: Although the following references were current when this NRTC was published, their continued currency cannot be assured. When consulting these references, keep in mind that they may have been revised to reflect new technology or

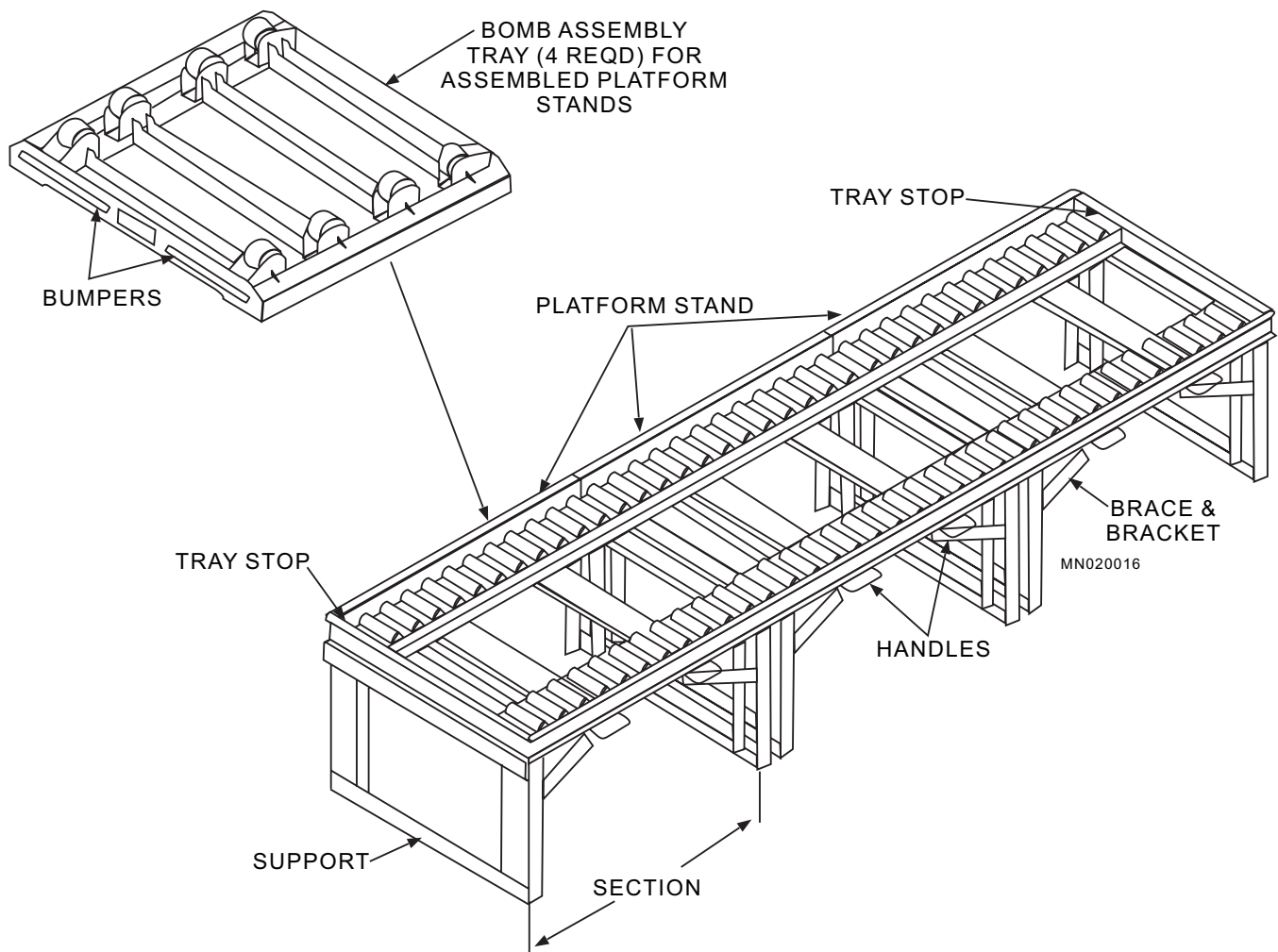

Figure 2-16.—Bomb assembly stand.

revised methods, practices, or procedures; therefore, you need to ensure that you are studying the latest revision.

Ammunition and Explosives Safety Ashore Regulations for Handling, Storing, Production, Renovation, and Shipping, NAVSEA OP 5, Volume 1, Naval Sea Systems Command, Washington, DC, 1990.

Bomb Assembly Platform Stand, A/F32K-1A Part Number 551AS100-1 and Small Bomb Assembly Platform Stand A/F32K-10 Part Number 551AS200-1, NAVAIR 19-15-27, Naval Air Systems Command, Washington, DC, 1989.

Handling Ammunition and Explosives with Industrial Materials Handling Equipment (MHE), NAVSEA SW023-AH-WHM-010, Naval Sea Systems Command, Washington, DC, 1976.

Handling, Packaging, Storing, and Transportation of Underwater Mines and Destructors for

Shore-Based/Shipboard Operations, NAVSEA SW023-M3-WHS-010, Naval Sea Systems Command, Washington, DC, 1990.

Mine Components A through C; Description and Class-B Criteria, NAVSEA SW550-AA-MMI-010, Naval Sea Systems Command, Washington, DC, 1988.

Motor Vehicle Driver and Shipping Inspector's Manual for Ammunition, Explosives, and Related Hazardous Materials, NAVSEA SW020-AF-ABK-010, Naval Sea Systems Command, Washington DC, 1980.

Periodic Testing Arrangements for Ordnance Handling Equipment, NAVSEA SG420-AP-MMA-010, Naval Sea Systems Command, Washington, DC, 1990.

APPENDIX I

GLOSSARY

The entries listed in this appendix are terms as they are used in this NRTC.

ASSEMBLY-LEVEL ITEM—A component, consisting of one or more parts, that is designed to function as an end item in a mine assembly.

ATOMIZATION—The process of reducing to fine particles or spray.

LONG-CYCLE MAINTENANCE—A specified interval of time at which programmed maintenance for mine assemblies is required.

MAINTENANCE—The actions required to retain material in a serviceable condition or to restore it to a serviceable condition.

MASTER RECORD SHEET (MRS)—A preprinted form used by IMAs and other authorized technicians to provide assembly, maintenance, and operational data for mines.

MINE BILL OF MATERIAL (MBOM)—A computer-produced, consolidated list for underwater-mine material.

SHORT-CYCLE MAINTENANCE—A specified interval of time at which programmed maintenance on assembled mines in configurations A, B, and C is required to be performed.

SPARES—The assembly-level items maintained on site in excess of those installed in mine assemblies.

VISCOSITY—The property of a fluid that resists the force tending to cause the fluid to flow.

VISUAL INSPECTION—The class-B testing of mine components by sight, test, or manipulation without the use of test instruments.

APPENDIX II

ABBREVIATIONS AND ACRONYMS

The entries listed in this appendix are abbreviations and acronyms as they are used in this NRTC.

CNO—Chief of Naval Operations

COMNAVSEASYSKOM—Commander, Naval Sea
Systems Command

EED—electro-explosive device

MBOM—mine bill of material

MHE—materials-handling equipment

MRS—master record sheet

MSDS—material safety data sheet

ORDALT—ordnance alteration

OSR—overhaul screening and repair

OSRS—overhaul screening and repair specification

PMS—programmed maintenance schedule

Q-D—quantity-distance

RFI—ready-for-issue

S&A—Safety Device and Arming Group

SCBA—self-contained breathing apparatus

TRS—technical repair standard

UNO—United Nations Organization

APPENDIX III

REFERENCES USED TO DEVELOP THIS NRTC

NOTE: Although the following references were current when this NRTC was published, their continued currency cannot be assured. When consulting these references, keep in mind that they may have been revised to reflect new technology or revised methods, practices, or procedures; therefore, you need to be sure that you are studying the latest references.

Ammunition and Explosives Safety Ashore Regulations for Handling, Storing, Production, Renovation, and Shipping, NAVSEA OP 5, Volume 1, Naval Sea Systems Command, Washington, D.C., 1990.

Bomb Assembly Platform Stand, A/F32K-1A Part Number 551AS100-1 and Small Bomb Assembly Platform Stand A/F32K-10 Part Number 551AS200-1, NAVAIR 19-15-27, Naval Air Systems Command, Washington, D.C., 1989.

Handling Ammunition and Explosives with Industrial Materials Handling Equipment (MHE), NAVSEA SW023-AH-WHM-010, Naval Sea Systems Command, Washington, D.C., 1976.

Handling, Packaging, Storing, and Transportation of Underwater Mines and Destructors for Shore-Based/Shipboard Operations, NAVSEA SW023-M3-WHS-010, Naval Sea Systems Command, Washington, D.C., 1990.

Mine Components A through C; Description and Class-B Criteria, NAVSEA SW550-AA-MMI-010, Naval Sea Systems Command, Washington, D.C., 1988.

Motor Vehicle Driver and Shipping Inspector's Manual for Ammunition, Explosives, and Related Hazardous Materials, NAVSEA SW020-AF-ABK-010, Naval Sea Systems Command, Washington, D.C., 1980.

Periodic Testing Arrangements for Ordnance Handling Equipment, NAVSEA SG420-AP-MMA-010, Naval Sea Systems Command, Washington, D.C., 1990.

Underwater Mine Maintenance System, NAVSEA SW550-FO-PMS-010, Naval Sea Systems Command, Washington, D.C., 1990.

ASSIGNMENT 1

Textbook Assignment: "Underwater Mine Maintenance System," chapter 1, pages 1-1 through 1-30.

- 1-1. The underwater mine maintenance system is described in which of the following publications?
 1. NAVSEA SW550-AA-MMI-010
 2. NAVSEA SW550-FO-PMS-010
 3. NAVSEA SW023-AB-WHS-010
 4. Each of the above
- 1-2. Mine system overhaul, screening, and repair specifications are used primarily by which of the following activities?
 1. Depots
 2. Fleet activities
 3. Intermediate maintenance activities
 4. Organizational maintenance activities
- 1-3. MOMAU activities perform which of the following types of maintenance?
 1. Organizational level
 2. Intermediate level
 3. Operational level
 4. Depot level
- 1-4. Mines may be stowed in what total number of authorized degrees of assembly configurations?
 1. One
 2. Five
 3. Three
 4. Six
- 1-5. Short-cycle maintenance is performed on which of the following assembly configurations?
 1. A only
 2. A and B only
 3. A, B, and C only
 4. A, B, C, D, and F
- 1-6. Assembly-level components are divided into four groups in accordance with which of the following publications?
 1. NAVSEA SW023-AB-WHS-010
 2. NAVSEA SW550-AA-MMI-010
 3. NAVSEA SW550-FO-PMS-010
 4. COMOMAGINST 4855.1H
- 1-7. When the urgency of the situation dictates, which of the following entities is authorized to extend the maintenance on mines afloat?
 1. COMOMAG
 2. COMINWARCOM
 3. Commanding officer
 4. Operational commander
- 1-8. The four groups of assembly-level components and the maintenance requirements for each can be found in which of the following publications?
 1. NAVSEA SW550-AA-MMI-010
 2. NAVSEA SW023-AB-WHS-010
 3. NAVSEA SW550-FO-PMS-010
 4. COMOMAGINST 4855.1H
- 1-9. The Mk 56 mine assembled to configuration D is subjected to class-B criteria every 6 years. If these mines meet the maintenance extension criteria, the maintenance cycle can be extended what total time?
 1. 6 years
 2. 2 years
 3. 3 years
 4. 4 years
- 1-10. An assembly-level item is a component that consists of one or more parts that are designed to function as an end item in a mine assembly.
 1. True
 2. False

- 1-11. Assembly-level items maintained as spares must receive the same maintenance as items installed mines, but the maintenance can be performed
1. any month during the year
 2. any quarter during the year
 3. any time within the specified quarter
 4. any time during the year at the discretion the commanding officer or the officer-in-charge
- 1-12. Instructions for the use of supplements A, B, E, F, and J are detailed on the back of each form. Which of the following publications supersedes these instructions?
1. NAVSEA SW550-AA-MMI-010
 2. NAVSEA SW550-AA-MMI-030
 3. NAVSEA SW023-AB-WHS-010
 4. NAVSEA SW550-FO-PMS-010

IN ANSWERING QUESTIONS 1-13 THROUGH 1-15, SELECT FROM THE FOLLOWING LIST THE CORRECT REPORT THAT SHOULD BE SUBMITTED FOR THE DEFINITION DESCRIBED IN THE QUESTION. ANSWERS MAY BE USED MORE THAN ONCE OR NOT AT ALL.

- A. Supplement A
- B. Supplement B
- C. Supplement E
- D. Supplement F

- 1-13. Problems dealing with improper packaging, nomenclature, and labeling.
1. A
 2. B
 3. C
 4. D
- 1-14. Safety and logistical problems.
1. A
 2. B
 3. C
 4. D
- 1-15. The completion of an ORDALT or MEFC.
1. A
 2. B
 3. C
 4. D

- 1-16. During the class-B testing of a group of 100 Mk 10 Mod 1 sterilizers for a lot of Mk 56 mines, failure of 40 sterilizers would require what type of report or supplement?
1. Message report
 2. Supplement E
 3. Supplement F
 4. UNITREP
- 1-17. To document assembly and maintenance data on a mine and to provide operational settings to that mine, you must complete what type of report or form?
1. Supplement B
 2. Supplement E
 3. Ammunition Transaction Report
 4. Assembly/Maintenance Master Record
- 1-18. To protect the watertight openings and the exposed threads while sandblasting a mine case, which of the following precautions should be taken?
1. Tape flanges and apply grease to threads
 2. Lightly grease flanges and exposed threads
 3. Install blanking plates and grease threads
 4. Install blanking plates and extra nuts and screws to cover threads
- 1-19. To remove corrosion from painted aluminum surfaces, you should use which of the following materials?
1. Wire brush
 2. Abrasive cloth
 3. Cleaning solvent only
 4. Sandblasting and cleaning solvent
- 1-20. External thermal-coated bombs are not considered thermally protected and are restricted from issue to aircraft carriers if they are missing more than what total number of square inches of thermal coating?
1. 7
 2. 2
 3. 3
 4. 6

1-21. The most commonly used primer is zinc chromate. When painting or sandblasting zinc chromate, what protective clothing must you wear?

1. Faceshield
2. Respirator
3. Leg stats
4. Goggles

1-22. The reliability of a manual torque wrench can be improved by exercising the wrench what minimum number of times?

1. Five
2. Two
3. Six
4. Eight

1-23. You should operate a manual torque wrench at what percent of its rated range?

1. 90
2. 80
3. 60
4. 50

1-24. When you are operating an pneumatic torque wrenche, what is the working psi required to operate the tool?

1. 70
2. 90
3. 110
4. 150

1-25. For the proper operation of a pneumatic torque wrench, it must be connected to an air supply that has which of the following components?

1. Moisture separator
2. Air-pressure regulator
3. Lubrication induction system
4. All of the above

1-26. When connecting an extension cord, you should always connect the electrical power tool to the extension cord first.

1. True
2. False

1-27. When using an extension cord, the combined length of the tool's cord and the extension cord must NOT exceed what total number of feet?

1. 20
2. 30
3. 40
4. 50

1-28. The speed of electrical power tools used on explosive-loaded components must NOT exceed what total number of rpms?

1. 1,000
2. 1,500
3. 2,000
4. 2,500

1-29. When a wire brush attachment is used with a drill, what is the maximum diameter of the wheel?

1. 8 inches
2. 6 inches
3. 5 inches
4. 4 inches

IN ANSWERING QUESTIONS 1-30 THROUGH 1-33, SELECT FROM THE FOLLOWING LIST THE TYPE OF SPRAY GUN DESCRIBED IN THE QUESTION. ANSWERS MAY BE USED MORE THAN ONCE OR NOT AT ALL.

- A. External mix
- B. Bleeder type
- C. Suction feed
- D. Internal mix

1-30. Which spray gun works on the same principle as an insect spray gun?

1. A
2. B
3. C
4. D

1-31. Which gun requires high air pressure?

1. A
2. B
3. C
4. D

1-32. The trigger controls only the fluid on which gun?

1. A
2. B
3. C
4. D

1-33. There is no pressure control on the air line of which gun?

1. A
2. B
3. C
4. D

1-34. A spray gun has what total number of main assemblies?

1. One
2. Two
3. Three
4. Four

1-35. Which part of the paint gun controls or regulates the flow of spray into the air stream?

1. Spreader adjustment valve
2. Air valve
3. Fluid tip
4. Air cap

IN ANSWERING QUESTIONS 1-36 THROUGH 1-39, SELECT THE SPRAY GUN CONTAINER USED FOR EACH PAINT JOB DESCRIBED IN THE QUESTION. ANSWERS MAY BE USED MORE THAN ONCE OR NOT AT ALL.

- A. Pressure tank
- B. Gravity-feed cup
- C. Suction-feed cup
- D. Pressure-feed cup

1-36. Spraying lacquer on small wall plaques.

1. A
2. B
3. C
4. D

1-37. Touch-up painting of equipment.

1. A
2. B
3. C
4. D

1-38. Painting small items that require fine adjustments and speed of application.

1. A
2. B
3. C
4. D

1-39. For a paint job requiring small cups to be attached to the top or side of the gun.

1. A
2. B
3. C
4. D

1-40. An air compressor used for painting provides air pressure within a nominal range of what psi?

1. 50 to 75
2. 100 to 125
3. 150 to 175
4. 175 to 200

1-41. During spray painting, what item is used to remove moisture from the air lines?

1. Air transformer
2. Air transducer
3. Check valve
4. Spring valve

1-42. When you are painting a flat surface with a spray gun, what position of the gun relative to the surface being painted is normally recommended?

1. Hold the spray gun at a right angle and a uniform distance (normally 6 to 10 inches) from the surface
2. Hold the spray gun at a right angle and at least 12 inches from the surface
3. Hold the spray gun at a 45° angle and a uniform distance (normally 6 to 10 inches) from the surface
4. Hold the spray gun at 45° angle and at least 12 inches from the surface

- 1-43. In starting and stopping each stroke with a paint spray gun, what practice should you follow?
1. Squeeze the trigger before starting the stroke; stop the stroke before releasing the trigger
 2. Squeeze the trigger before starting the stroke; release the trigger before stopping the stroke
 3. Start the stroke before squeezing the trigger; release the trigger before stopping the stroke
 4. Start the stroke before squeezing the trigger; stop the stroke before releasing the trigger

IN ANSWERING QUESTIONS 1-44 THROUGH 1-47, SELECT FROM THE FOLLOWING LIST THE DEFECT THAT IS CAUSED BY THE FACTOR PRESENTED IN THE QUESTION. ANSWERS MAY BE USED MORE THAN ONCE OR NOT AT ALL.

- A. Orange peel
- B. Blushing
- C. Peeling
- D. Bleeding

1-44. Wrong thinner.

1. A
2. B
3. C
4. D

1-45. Excessive moisture in the air.

1. A
2. B
3. C
4. D

1-46. Use of cheap spray materials.

1. A
2. B
3. C
4. D

1-47. Dirty surface.

1. A
2. B
3. C
4. D

1-48. When chemical compounds of a previously applied coat discolor the finish coat, this is referred to as what defect?

1. Runs
2. Peeling
3. Bleeding
4. Orange peel

IN ANSWERING QUESTIONS 1-49 THROUGH 1-52, SELECT FROM THE FOLLOWING LIST THE POSSIBLE CAUSE FOR THE PROBLEM DESCRIBED IN THE QUESTION. ANSWERS MAY BE USED MORE THAN ONCE OR NOT AT ALL.

- A. Dirt on the air cap
- B. Bent valve stem
- C. Wrong size needle
- D. Clogged air vent in container lid

1-49. Air leaks from front of the gun.

1. A
2. B
3. C
4. D

1-50. Jerky spray (suction feed only).

1. A
2. B
3. C
4. D

1-51. Defective spray pattern.

1. A
2. B
3. C
4. D

1-52. Fluid leaks from front of gun.

1. A
2. B
3. C
4. D

1-53. The ingredient used to give color to paint is known as the

1. drier
2. vehicle
3. thinner
4. pigment

- 1-54. The liquid portion of the paint that acts as the binder is known by which two of the following terms?
1. Vehicle or base
 2. Vehicle or bottom
 3. Base or adhesive
 4. Base or oil
- 1-55. Metallic compounds that are added to paint increase the ability to
1. mix
 2. dry
 3. bind
 4. penetrate
- 1-56. The use of thinner with paint serves two purposes. One is to reduce the consistency of the paint for application by spraying or brushing. What is the other purpose?
1. To give a gloss finish once it is dried
 2. To take oxygen from the air and add it to the oil
 3. To increase the penetration of the paint, cutting down on the gloss
 4. To decrease the active pigments, preventing caking and clogging
- 1-57. When no mechanical mixer is available, what is the best method for mixing paint?
1. Perform boxing only
 2. Mix with stir stick, then perform boxing
 3. Pour off vehicle, mix remainder, add vehicle in small amounts, then perform boxing
 4. Pour off vehicle, mix remainder, add all of the remaining vehicle at once, then perform boxing
- 1-58. Painting should NOT be done when the temperature is below what minimum temperature?
1. 32 °F
 2. 42 °F
 3. 52 °F
 4. 60 °F
- 1-59. For best painting results, paint when the temperature is between
1. 50 °F and 70 °F
 2. 55 °F and 75 °F
 3. 60 °F and 80 °F
 4. 65 °F and 85 °F
- 1-60. Spray painting equipment can produce several thousand volts of static electricity. When painting an explosive-loaded mine case, what should you do to eliminate this hazard?
1. Ground mine case only
 2. Ground spray gun nozzle only
 3. Ground mine case and spray gun nozzle to separate earth grounds
 4. Ground mine case and spray gun nozzle to the same earth ground
- 1-61. In the interest of good health when spray painting, you should wear clothes that fit (a) how at the neck, ankles, and wrist; and the parts of your body NOT covered by clothing should be protected (b) by what method?
1. (a) Loosely (b) vaseline
 2. (a) Loosely (b) protective cream
 3. (a) Tightly (b) vaseline
 4. (a) Tightly (b) protective cream
- 1-62. When spray painting the interior of a tank, the use of which of the following respirators will give you the best protection?
1. Supplied air
 2. Cartridge
 3. Filter
 4. Dust
- 1-63. For sandblasting operations, you should use which of the following respirators?
1. Supplied air
 2. Cartridge
 3. Filter
 4. Dust
- 1-64. Cadmium-mercury cell batteries should be stored at what temperature range where they will deteriorate at a normal rate?
1. 56 ° F to 65 °F
 2. 65 °F to 80 °F
 3. 21 °F to 95 °F
 4. Ordinary ambient temperature
- 1-65. Batteries removed from their outer containers, but not from their polyethylene bags, are being thawed by which of the following procedures?
1. Normal thaw
 2. Standard rapid thaw
 3. Either normal or standard rapid thaw
 4. Alternate rapid thaw

1-66. Batteries failing class-B testing after thawing should be set aside what total time before retesting?

1. 12 hours
2. 24 hours
3. 36 hours
4. 48 hours

ASSIGNMENT 2

Textbook Assignment: "Mine Handling and Storage," chapter 2, pages 2-1 through 2-23.

- 2-1. Tasks performed repeatedly, no matter how dangerous, are likely to become routine and lead to carelessness.
1. True
 2. False
- 2-2. Accidents are usually the result of which of the following factors?
1. Failure to follow regulations
 2. Failure to understand hazards
 3. Failure to take necessary precautions
 4. All of the above
- 2-3. The sole responsibility for an activity's safe handling, transportation, and storage of explosives lies with which of the following personnel?
1. Safety officer only
 2. Executive officer only
 3. Commanding officer only
 4. All personnel involved
- 2-4. When discussing ordnance regulations, which of the following words are meant as mandatory?
1. May and should
 2. Should and shall only
 3. Shall, should, and must
 4. Will, shall, and must
- 2-5. Technicians, or operating personnel, are responsible for reading, understanding, and strictly observing all safety standards, requirements and precautions applicable to their work or duty.
1. True
 2. False
- 2-6. If an unauthorized person enters the area of operations, the person engaged in ammunition-handling operations should take what immediate action?
1. Order the unauthorized person to leave the area
 2. Apprehend the unauthorized person
 3. Call the officer of the day
 4. Notify the supervisor
- 2-7. For detailed information on safety regulations, you should refer to which of the following publications?
1. NAVSEA OP 5, Volume 1
 2. NAVSEA OP 2165, Volume 1
 3. NAVSEA SW550-AA-MMI-010
 4. NAVSEA SW550-FO-PMS-010
- 2-8. The responsibility for ensuring that personnel limits are not exceeded lies with which of the following personnel?
1. The supervisor
 2. The department head
 3. The commanding officer or officer-in-charge
 4. Quality assurance personnel
- 2-9. When determining personnel limits in mine-handling and storage buildings, which of the following factors must be considered?
1. Type of building
 2. Nature of work involved
 3. Degree of hazard present
 4. All of the above
- 2-10. Personnel limits for operating buildings or magazines are set by which of the following personnel?
1. CNO
 2. NAVSEASYSKOM
 3. COMINWARCOM
 4. Commanding officer

- 2-11. The explosive limit of a building includes explosive items in vehicles but NOT those stored in the adjacent area outside the building.
1. True
 2. False
- 2-12. Personnel limit signs on operating buildings must have what minimum size lettering?
1. 1 inch
 2. 2 inches
 3. 3 inches
 4. 4 inches
- 2-13. When determining explosive limits, which of the following factors must be considered?
1. The type of magazine only
 2. The type of magazine and hazards involved only
 3. The type of magazine, hazards involved, and quantity-distance relationship
 4. The hazards involved, quantity-distance relationship, and distance to nearest roadway
- 2-14. Posted explosive limits may be expressed in which of the following ways?
1. By number of items only
 2. By net explosive weight only
 3. By the number of containers only
 4. By number of items, net explosive weight, or containers
- 2-15. If the explosive limit of a building is exceeded, which of the following actions must be taken?
1. The commanding officer or officer-in-charge must be notified
 2. All operations must be discontinued
 3. The nearest EOD team must be notified
 4. All of the above
- 2-16. After a fuel spill, a vehicle must be towed what minimum distance before it can be started?
1. 20 feet
 2. 50 feet
 3. 100 feet
 4. 150 feet
- 2-17. The refueling of gasoline- or diesel-powered MHE must be accomplished no less than what total number of feet from the nearest explosive area?
1. 100
 2. 20
 3. 60
 4. 80
- 2-18. Grass and brush must be maintained at what maximum (a) height, in inches, and (b) distance, in feet, from operating buildings?
1. (a) 18 (b) 5
 2. (a) 18 (b) 50
 3. (a) 24 (b) 50
 4. (a) 24 (b) 100
- IN ANSWERING QUESTIONS 2-19 THROUGH 2-21, SELECT FROM THE FOLLOWING LIST THE SYMBOL DESCRIBED IN THE QUESTION. ANSWERS MAY BE USED MORE THAN ONCE OR NOT AT ALL.
- A. Fire division
 - B. Fire-fighting direction
 - C. Chemical hazard
 - D. Magazine designator
- 2-19. Which of the following symbols represents explosive divisions?
1. A
 2. B
 3. C
 4. D
- 2-20. Which of the following symbols indicates toxic fumes?
1. A
 2. B
 3. C
 4. D
- 2-21. Which of the following symbols gives explosive characteristics?
1. A
 2. B
 3. C
 4. D

- 2-22. The posting of firefighting symbols must be visible during daylight from a distance of at least 500 feet. If visibility is obstructed, the symbol must be placed on the roadway at what minimum distance, in feet?
1. 100
 2. 200
 3. 250
 4. 500
- 2-23. Magazines of all types, including open storage sites, containing ammunition, must be marked to provide rapid and positive identification. These buildings must be marked with which of the following minimum requirements?
1. Magazine type only
 2. Magazine type and sequence number
 3. Magazine group number
 4. Building number
- 2-24. The identification numbers on magazines and buildings must be of what minimum height, in inches?
1. 5
 2. 6
 3. 3
 4. 12
- 2-25. A power ground has which of the following purposes?
1. Prevent arcing only
 2. Protect equipment from overvoltage only
 3. Prevent shock to personnel only
 4. Prevent arcing, protect equipment from over-voltage, and prevent shock to personnel
- 2-26. Static ground systems can NOT be connected/interconnected to which of the following items?
1. Water pipes
 2. Ordnance grounds
 3. Secondary ground system
 4. Rods driven into the ground
- 2-27. Ground systems should be inspected at what specific interval?
1. Every 3 months
 2. Every 4 months
 3. Every 6 months
 4. Every 24 months
- 2-28. Which of the following operations is permitted in and around magazines?
1. Bolstering and debolstering
 2. Palletizing for shipment
 3. Painting and stenciling
 4. All of the above
- 2-29. A red flag must be displayed at the entrance to each magazine where there is work to be performed.
1. True
 2. False
- 2-30. Ammunition and explosives may be stored in operating buildings provided that which of the following requirements are observed?
1. The approved limits are not exceeded
 2. The compatibility requirements are met
 3. The building is equipped with an automatic sprinkler system
 4. All of the above
- 2-31. All ammunition must be removed from an explosive operating building if the building is to be inactive in excess of what time frame?
1. 48 hours
 2. 72 hours
 3. 108 hours
 4. 132 hours
- 2-32. Magazines must be inspected at a minimum of how often?
1. Before initial use only
 2. Before reuse use only
 3. Before both initial use and reuse
 4. Every 12 months
- 2-33. Quantity-distance requirements are established for which of the following purposes?
1. To simplify handling
 2. To protect personnel from injury
 3. To provide maximum storage in magazines
 4. To ensure proper segregation of explosive materials
- 2-34. The United Nations Organization hazard classification system consists of how many classes of dangerous materials?
1. Nine
 2. Two
 3. Seven
 4. Four

2-35. Hazard class-1 material is further subdivided into what total number of divisions?

1. Eight
2. Two
3. Six
4. Four

2-36. The procedures for requesting exemptions and waivers are contained in which of the following publications?

1. NAVSEA OP 5, Volume 1
2. NAVSEA SW020-AC-SAF-010
3. NAVSEAINST 8023.20
4. OPNAVINST 8020.14

2-37. An exemption may be granted for a maximum period of (a) years, and a waiver may be granted for a maximum period of (b) years.

1. (a) 5 (b) 1
2. (a) 5 (b) 2
3. (a) 2 (b) 5
4. (a) 1 (b) 5

IN ANSWERING QUESTIONS 2-38 THROUGH 2-41, SELECT FROM THE FOLLOWING LIST THE MHE TYPE THAT IS DESCRIBED IN THE QUESTION. ANSWERS MAY BE USED MORE THAN ONCE OR NOT AT ALL.

- A. DS
- B. EE
- C. EX
- D. HS

2-38. Diesel powered with additional safeguards.

1. A
2. B
3. C
4. D

2-39. Hand powered with nonsparking wheels.

1. A
2. B
3. C
4. D

2-40. Generally referred to as explosion proof.

1. A
2. B
3. C
4. D

2-41. May be used in atmospheres containing combustible dust.

1. A
2. B
3. C
4. D

2-42. A forklift should have printed, in view of the operator at all times, which of the following information?

1. Next test date
2. Manufacture date
3. Alphabetic designator
4. Safe working load and weight test date

2-43. Tests for MHE used at shore activities must NOT exceed 500 operational hours or what total number of months?

1. 14
2. 12
3. 10
4. 6

2-44. To operate motor vehicles transporting hazardous material on station, you must be at least what age?

1. 17
2. 18
3. 21
4. 25

2-45. A U.S. Government Motor Vehicle Operator's Identification Card is what standard form?

1. 26
2. 41
3. 46
4. 91

2-46. MHE is marked for identification of use by which of the following characteristics?

1. 4-inch, black, block letters on both sides and the rear
2. 3-inch, black, block letters on both sides and the rear
3. 4-inch, blue, block letters on both sides and the rear
4. 3-inch, blue, block letters on both sides and the rear

2-47. An explosives driver's course is at least what total number of hours?

1. 48
2. 24
3. 12
4. 6

2-48. Drivers of vehicles transporting hazardous materials off-station must be at least 21 years old.

1. True
2. False

2-49. Portable ordnance-handling equipment (PHOE) used ashore must be tested at what minimum interval?

1. Every 6 months
2. Every 12 months
3. Every 14 months
4. Every 24 months

2-50. POHE must be tested to what percent of its design load?

1. 110
2. 100
3. 50
4. 40

2-51. For information pertaining to the testing of POHE, you should refer to which of the following publications?

1. NAVSEA SW550-AA-MMI-010
2. NAVSEA SW550-FO-PMS-010
3. NAVSEA SG420-AP-MMA-010
4. NAVSEA SW023-AB-WHS-010

2-52. Before being used, nonmetallic nylon slings should be inspected for which of the following defects?

1. Cuts and frayed threads only
2. Cuts and broken stitches only
3. Frayed threads and broken stitches only
4. Cuts, frayed threads, and broken stitches

2-53. After portable ordnance-handling equipment has been satisfactorily tested, it should be marked in which of the following ways?

1. Testing facility only
2. Date tested and safe working load only
3. Testing facility, safe working load, and date tested only
4. Testing facility, safe working load, date tested, and next test date

IN ANSWERING QUESTIONS 2-54 THROUGH 2-57, SELECT FROM THE FOLLOWING LIST THE SLING THAT SHOULD BE USED TO PERFORM THE TASK DESCRIBED IN THE QUESTION. ANSWERS MAY BE USED MORE THAN ONCE OR NOT AT ALL.

- A. Mk 95
- B. Mk 99
- C. Mk 101
- D. Mk 111

2-54. Is used for hoisting operations when marrying sections of the Mk 67 mine.

1. A
2. B
3. C
4. D

2-55. Is used to lift the Mk 56 mine in and out of its crate.

1. A
2. B
3. C
4. D

2-56. Has a lifting capacity of 6,000 pounds.

1. A
2. B
3. C
4. D

2-57. Is used for loading 21-inch diameter mines aboard submarines.

1. A
2. B
3. C
4. D

2-58. The Mk 49 Mod 1 weapon carrier has what total lifting capacity?

1. 1,500 pounds
2. 2,500 pounds
3. 3,000 pounds
4. 4,000 pounds

- 2-59. The Mk 55 weapon carrier has what total lifting capacity?
1. 1,500 pounds
 2. 2,500 pounds
 3. 3,000 pounds
 4. 4,000 pounds
- 2-60. The Mk 11 Mod 1 dolly has adjustable wheels that provide bearing surfaces for cylindrical weapons of what diameter?
1. 8 1/2 to 21 inches
 2. 9 to 22 1/2 inches
 3. 11 to 22 1/2 inches
 4. 11 1/2 to 23 inches
- 2-61. The Mk 21 Mod 0 dolly has what total weight capacity?
1. 1,000 pounds
 2. 1,500 pounds
 3. 1,600 pounds
 4. 1,800 pounds
- 2-62. The Aero 51B munitions trailer has what total weight capacity?
1. 8,500 pounds
 2. 9,500 pounds
 3. 10,000 pounds
 4. 5,000 pounds
- 2-63. The Aero 51B munitions trailer can be towed in trains not to exceed how many trailers?
1. 5
 2. 2
 3. 3
 4. 4
- 2-64. When more than one Aero 51B munitions trailer is being towed, what is the maximum speed allowed?
1. 10 mph
 2. 20 mph
 3. 30 mph
 4. 25 mph
- 2-65. The gantry A-frame has what specific adjustable working height?
1. 10 to 17 feet
 2. 10 to 24 feet
 3. 8 to 16 feet
 4. 8 to 21 feet
- 2-66. What is the maximum safe working load that must NEVER be exceeded by the gantry A-frame?
1. 1,500 pounds
 2. 2,000 pounds
 3. 3,000 pounds
 4. 4,000 pounds
- 2-67. Maintenance and testing of the bomb assembly stand must be accomplished in accordance with which of the following publications?
1. NAVSEA OP 4098
 2. NAVSEA OP 5, Volume 1
 3. NAVSEA SW023-AB-WHS-010
 4. NAVSEA AG-220B0-MRC-010