



**NONRESIDENT
TRAINING
COURSE**



July 2002

**Aviation Support
Equipment Technician
(AS)**

NAVEDTRA 14329

DISTRIBUTION STATEMENT A: Approved for public release; distribution is unlimited.

Although the words “he,” “him,” and “his” are used sparingly in this course to enhance communication, they are not intended to be gender driven or to affront or discriminate against anyone.

DISTRIBUTION STATEMENT A: Approved for public release; distribution is unlimited.

PREFACE

By enrolling in this self-study course, you have demonstrated a desire to improve yourself and the Navy. Remember, however, this self-study course is only one part of the total Navy training program. Practical experience, schools, selected reading, and your desire to succeed are also necessary to successfully round out a fully meaningful training program.

COURSE OVERVIEW: Provides basic information on support equipment mechanical, electrical, hydraulic, pneumatic, and cryogenic systems.

THE COURSE: This self-study course is organized into subject matter areas, each containing learning objectives to help you determine what you should learn along with text and illustrations to help you understand the information. The subject matter reflects day-to-day requirements and experiences of personnel in the rating or skill area. It also reflects guidance provided by Enlisted Community Managers (ECMs) and other senior personnel, technical references, instructions, etc., and either the occupational or naval standards, which are listed in the *Manual of Navy Enlisted Manpower Personnel Classifications and Occupational Standards*, NAVPERS 18068.

THE QUESTIONS: The questions that appear in this course are designed to help you understand the material in the text.

VALUE: In completing this course, you will improve your military and professional knowledge. Importantly, it can also help you study for the Navy-wide advancement in rate examination. If you are studying and discover a reference in the text to another publication for further information, look it up.

*2002 Edition Prepared by
ASC(AW) Donna Brueggeman*

Published by
NAVAL EDUCATION AND TRAINING
PROFESSIONAL DEVELOPMENT
AND TECHNOLOGY CENTER

**NAVSUP Logistics Tracking Number
0504-LP-101-5590**

Sailor's Creed

"I am a United States Sailor.

I will support and defend the Constitution of the United States of America and I will obey the orders of those appointed over me.

I represent the fighting spirit of the Navy and those who have gone before me to defend freedom and democracy around the world.

I proudly serve my country's Navy combat team with honor, courage and commitment.

I am committed to excellence and the fair treatment of all."

TABLE OF CONTENTS

CHAPTER	PAGE
1. The Aviation Support Equipment (As) Rating.....	1-1
2. Chassis And Attaching Systems.....	2-1
3. Principles Of Internal Combustion Engines.....	3-1
4. Internal Combustion Engine Fuel Systems	4-1
5. Internal Combustion Engine Cooling And Lubricating Systems.....	5-1
6. Automotive Electrical Systems And Equipment.....	6-1
7. Power Generating Systems	7-1
8. Hydraulic Systems And Equipment.....	8-1
9. Pneumatics	9-1
10. Liquid And Gaseous Oxygen Systems And Equipment	10-1
11. Mobile Air-Conditioners.....	11-1
12. Gas Turbine Compressors	12-1
13. Shipboard Flight deck Equipment.....	13-1
APPENDIX	
I. Glossary	AI-1
II. References Used to Develop the Nonresident Training Course.....	AII-1
III. Answers to Review Questions.....	AIII-1

ASSIGNMENT QUESTIONS follow Appendix III.

INSTRUCTIONS FOR TAKING THE COURSE

ASSIGNMENTS

The text pages that you are to study are listed at the beginning of each assignment. Study these pages carefully before attempting to answer the questions. Pay close attention to tables and illustrations and read the learning objectives. The learning objectives state what you should be able to do after studying the material. Answering the questions correctly helps you accomplish the objectives.

SELECTING YOUR ANSWERS

Read each question carefully, then select the BEST answer. You may refer freely to the text. The answers must be the result of your own work and decisions. You are prohibited from referring to or copying the answers of others and from giving answers to anyone else taking the course.

SUBMITTING YOUR ASSIGNMENTS

To have your assignments graded, you must be enrolled in the course with the Nonresident Training Course Administration Branch at the Naval Education and Training Professional Development and Technology Center (NETPDTC). Following enrollment, there are two ways of having your assignments graded: (1) use the Internet to submit your assignments as you complete them, or (2) send all the assignments at one time by mail to NETPDTC.

Grading on the Internet: Advantages to Internet grading are:

- you may submit your answers as soon as you complete an assignment, and
- you get your results faster; usually by the next working day (approximately 24 hours).

In addition to receiving grade results for each assignment, you will receive course completion confirmation once you have completed all the

assignments. To submit your assignment answers via the Internet, go to:

<https://courses.cnet.navy.mil>

Grading by Mail: When you submit answer sheets by mail, send all of your assignments at one time. Do NOT submit individual answer sheets for grading. Mail all of your assignments in an envelope, which you either provide yourself or obtain from your nearest Educational Services Officer (ESO). Submit answer sheets to:

COMMANDING OFFICER
NETPDTC N331
6490 SAUFLEY FIELD ROAD
PENSACOLA FL 32559-5000

Answer Sheets: All courses include one "scannable" answer sheet for each assignment. These answer sheets are preprinted with your SSN, name, assignment number, and course number. Explanations for completing the answer sheets are on the answer sheet.

Do not use answer sheet reproductions: Use only the original answer sheets that we provide—reproductions will not work with our scanning equipment and cannot be processed.

Follow the instructions for marking your answers on the answer sheet. Be sure that blocks 1, 2, and 3 are filled in correctly. This information is necessary for your course to be properly processed and for you to receive credit for your work.

COMPLETION TIME

Courses must be completed within 12 months from the date of enrollment. This includes time required to resubmit failed assignments.

PASS/FAIL ASSIGNMENT PROCEDURES

If your overall course score is 3.2 or higher, you will pass the course and will not be required to resubmit assignments. Once your assignments have been graded you will receive course completion confirmation.

If you receive less than a 3.2 on any assignment and your overall course score is below 3.2, you will be given the opportunity to resubmit failed assignments. **You may resubmit failed assignments only once.** Internet students will receive notification when they have failed an assignment—they may then resubmit failed assignments on the web site. Internet students may view and print results for failed assignments from the web site. Students who submit by mail will receive a failing result letter and a new answer sheet for resubmission of each failed assignment.

COMPLETION CONFIRMATION

After successfully completing this course, you will receive a letter of completion.

ERRATA

Errata are used to correct minor errors or delete obsolete information in a course. Errata may also be used to provide instructions to the student. If a course has an errata, it will be included as the first page(s) after the front cover. Errata for all courses can be accessed and viewed/downloaded at:

<https://www.advancement.cnet.navy.mil>

STUDENT FEEDBACK QUESTIONS

We value your suggestions, questions, and criticisms on our courses. If you would like to communicate with us regarding this course, we encourage you, if possible, to use e-mail. If you write or fax, please use a copy of the Student Comment form that follows this page.

For subject matter questions:

E-mail: n315.products@cnet.navy.mil
Phone: Comm: (850) 452-1001, ext. 1775
DSN: 922-1001, ext. 1775
FAX: (850) 452-1370
(Do not fax answer sheets.)
Address: COMMANDING OFFICER
NETPDTC N3441
6490 SAUFLEY FIELD ROAD
PENSACOLA FL 32509-5237

For enrollment, shipping, grading, or completion letter questions

E-mail: fleetservices@cnet.navy.mil
Phone: Toll Free: 877-264-8583
Comm: (850) 452-1511/1181/1859
DSN: 922-1511/1181/1859
FAX: (850) 452-1370
(Do not fax answer sheets.)
Address: COMMANDING OFFICER
NETPDTC N331
6490 SAUFLEY FIELD ROAD
PENSACOLA FL 32559-5000

NAVAL RESERVE RETIREMENT CREDIT

If you are a member of the Naval Reserve, you may earn retirement points for successfully completing this course, if authorized under current directives governing retirement of Naval Reserve personnel. For Naval Reserve retirement, this course is evaluated at 15 points.

Unit 1, assignments 1 through 8, 12 points.

Unit 2, assignments 9 through 10, 3 points.

(Refer to *Administrative Procedures for Naval Reservists on Inactive Duty*, BUPERSINST 1001.39, for more information about retirement points.)

CREDITS

The illustrations indicated below are included in this edition of *Aviation Support Equipment Technician (AS)*, NAVEDTRA 14329, through the courtesy of the designated company. Permission to use the illustrations is gratefully acknowledged.

SOURCE	FIGURE
The Tennant Company	13-12, 13-13, 13-14, and 13-15

Student Comments

Course Title: Aviation Support Equipment Technician

NAVEDTRA: 14329 Date: _____

We need some information about you:

Rate/Rank and Name: _____ SSN: _____ Command/Unit _____

Street Address: _____ City: _____ State/FPO: _____ Zip _____

Your comments, suggestions, etc.:

Privacy Act Statement: Under authority of Title 5, USC 301, information regarding your military status is requested in processing your comments and in preparing a reply. This information will not be divulged without written authorization to anyone other than those within DOD for official use in determining performance.

NETPDTC 1550/41 (Rev 4-00)

CHAPTER 1

THE AVIATION SUPPORT EQUIPMENT (AS) RATING

INTRODUCTION

The job of the Aviation Support Equipment Technician (AS) requires an understanding of the fundamentals of electrical, mechanical, and hydraulic maintenance. The information presented in this course deals with fundamentals and is intended to help candidates for AS3 and AS2 prepare for advancement in rate exams. Even personnel studying for AS1 and ASC will find the information useful, as they are still responsible for material covered at the lower grades. This *Aviation Support Equipment Technician Nonresident Training Course* replaces AS3, NAVEDTRA 10356; AS2, NAVEDTRA 10357; and AS1, NAVEDTRA 10358.

Minimum occupational requirements for advancement in all ratings are listed in the *Manual of Navy Enlisted Manpower and Personnel Classifications and Occupational Standards*, NAVPERS 18068 (series).

RATING HISTORY

LEARNING OBJECTIVE: Identify important points about the history of the Aviation Support Equipment Technician rating.

The AS rating is new when compared to other ratings. On 24 February 1966, BUPERSNOTE 1440 announced that a new rating (AS) was being established. Personnel from all rates throughout the Navy applied for conversion to the AS rating, and on 18 August 1966, BUPERSNOTE 1430 named 1,119 candidates who were selected for conversion. Technicians came from ratings such as Aviation Electrician's Mate, Aviation Machinist's Mate, Aviation Ordnanceman, and Aviation Structural Mechanic. Personnel from non-aviation ratings, such as Boatswain's Mate, Electronics Technician, and Machinist's Mate were also converted.

The Aviation Support Equipment Technician rating was initially divided into three service ratings: ASE, ASH, and ASM. On 9 September 1967, the first AS class A school convened at NATTC, Memphis. The school was divided into three sections (fingers), an ASE finger, an ASH finger, and an ASM finger. The ASE class A school taught students basic electricity, troubleshooting, and safety. The ASM and ASH class A schools taught basic mechanics, hydraulics, and

structures. In 1980, the ASH service rating was integrated into the ASM service rating, and in 1990, the ASM and ASE service ratings were combined into a single AS rating.

The future for the AS rating seems to hold more exciting changes. In 1996 the A school was moved to NATTC Pensacola, and with a new, modern building, the AS class A school is designed to provide the student with the latest logic trainers, first off the assembly line equipment, centralized training, and the best instructors the fleet has to offer.

Figure 1-1 illustrates the paths of advancement for an Airman Recruit to Master Chief Aviation Support Equipment Technician and beyond.

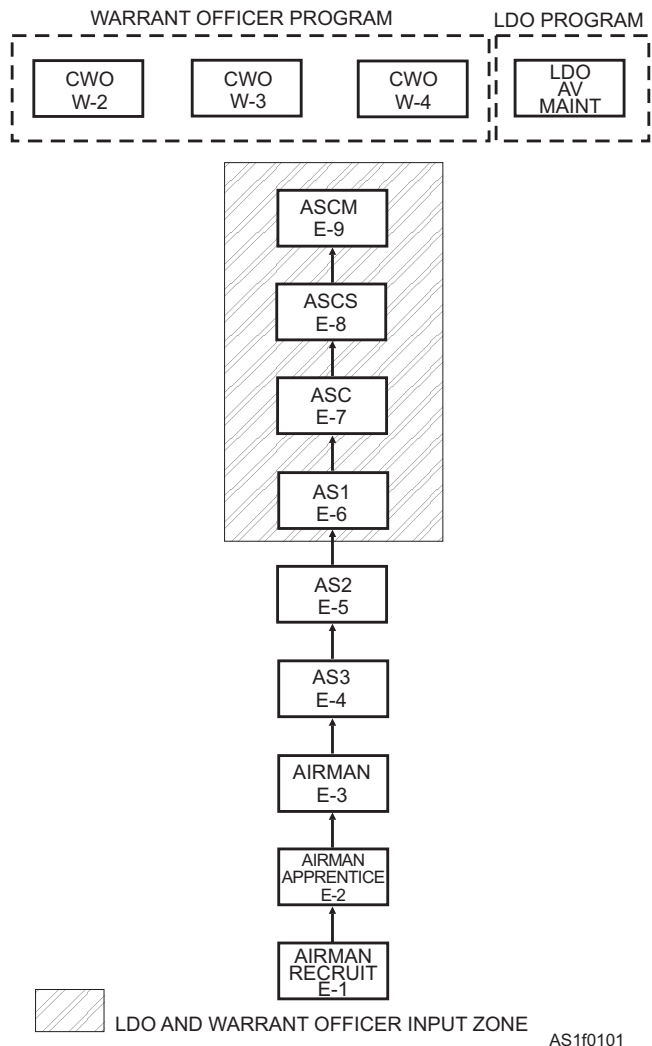

Figure 1-1.—Paths of advancement.

Q1-1. In what publication can you find the minimum occupational requirements for advancement?

1. *NAVPERS 18068 (series)*
2. *NAVPERS 12843 (series)*
3. *BUPERS 60415 (series)*
4. *BUPERS 15423 (series)*

Q1-2. On what date did BUPERSNOTE 1440 announce the AS rating was being established?

1. *18 August 1966*
2. *24 September 1956*
3. *24 February 1966*
4. *4 June 1956*

NAVY ENLISTED CLASSIFICATION (NEC) CODES

LEARNING OBJECTIVE: Identify the job functions associated with Navy Enlisted Classification (NEC) codes for the Aviation Support Equipment Technician rating.

The Navy Enlisted Classification (NEC) coding system was designed to match the right person with the right job. The NEC identifies billets that require special skills, and then identifies those people able to develop those skills. The NEC system provides the Navy with a way to maximize its manpower. Any person who gains the qualifications associated with one of the special skills is given an NEC code. The NECs available to the AS are discussed in this lesson.

AS-7601 SUPPORT EQUIPMENT CRYOGENIC MECHANIC

To acquire this NEC, you must perform on-equipment repairs and intermediate-level maintenance on liquid oxygen servicing trailers, gaseous oxygen servicing trailers, nitrogen servicing trailers, walk-around bottles, and oxygen systems purging equipment. You must also repair regulators, valves, manifolds, pumps, and gauges.

AS-7603 SUPPORT EQUIPMENT AIR-CONDITIONING TECHNICIAN

This NEC requires on-equipment repairs and intermediate-level maintenance on mobile air conditioners and HBO-36 air-conditioners. You must also troubleshoot and repair high- and low-pressure air-conditioning systems and electrical control circuits and components. You must perform repairs on

compressors, condensers, lines, valves, and regulators of air-conditioning systems.

AS-7606 SUPPORT EQUIPMENT GAS TURBINE MECHANIC

To acquire this NEC, you must perform on-equipment repair and intermediate-level maintenance on gas turbine units. You must also troubleshoot and repair air and electrical control systems, fuel systems, bleed air systems, oil systems, and power-generating systems. You must also repair and adjust fuel controls, flow dividers, oil and fuel pumps, generators, motors, relays, voltage regulators, thermostats, and air valves.

AS-7607 SHORE SUPPORT EQUIPMENT TOW TRACTOR TECHNICIAN

This NEC requires performance of on-equipment repairs and intermediate-level maintenance on gasoline and diesel engines, drive trains, brakes, and steering systems installed in mobile and self-propelled support equipment, including starting, ignition, hydraulic and pneumatic systems and their components.

AS-7609 SUPPORT EQUIPMENT MAINTENANCE MANAGER

To acquire this NEC, you must plan, organize, implement, and control maintenance on all assigned support equipment in compliance with policy statements and directives issued by NAVAIR, type commanders, and local commands. You must implement and supervise aviation programs and operator training. You must demonstrate management skills in the preventive maintenance system on assigned support equipment. You must also be able to manage the professional and damage control (afloat) personnel qualifications standards (PQS) for all assigned personnel.

AS-7610 WEAPONS HANDLING/LOADING EQUIPMENT MECHANIC

This NEC requires performance of equipment repairs and intermediate-level maintenance on the Raymond reach fork, the Allis Chalmers reach fork, and the HLU-196 weapons loader. You must troubleshoot and repair hydraulic systems and drive systems, hydraulic and electric control circuits and components, and mechanical drive and control systems.

AS-7612 AFLOAT SUPPORT EQUIPMENT HYDRAULIC IMA TECHNICIAN

To acquire this NEC, you must perform on-equipment repairs and intermediate-level maintenance on hydraulic test stands, pallet transporters, aircraft spotting dollies, and aircraft jacks. You must also troubleshoot and repair hydraulic electrical and electrical control circuits and drive systems, hydraulic power supplies, hydraulic cylinders, flow dividers, and hydraulic pumps.

AS-7613 SHORE-BASED SUPPORT EQUIPMENT HYDRAULIC IMA TECHNICIAN

To acquire this NEC, you must perform on-equipment repairs and intermediate-level maintenance on hydraulic test stands and aircraft jacks. You must also troubleshoot and repair hydraulic electrical and electrical control circuits and hydraulic power supplies, hydraulic cylinders, flow dividers, and hydraulic pumps.

AS-7614 SHORE-BASED MOBILE ELECTRIC POWER PLANTS (MEPPS) IMA TECHNICIAN

This NEC requires on-equipment repairs and intermediate-level maintenance on shore-based mobile electric power plants (MEPPs). It also requires troubleshooting and repairs on electric motors, generators, voltage regulator systems, overvoltage and undervoltage systems, frequency control systems, fault indicator systems, and other control circuits. You are also required to repair voltage regulators, motors, rectifiers, oscillators, and magnetic amplifiers.

AS-7615 AFLOAT MOBILE ELECTRIC POWER PLANT (MEPPS) TECHNICIAN

This NEC requires on-equipment repairs and intermediate-level maintenance on MEPPs. It also requires troubleshooting and repairs on electric motors, generators, voltage regulator systems, overvoltage and undervoltage systems, frequency control systems, fault indicator systems, and other control circuits. You are also required to repair voltage regulators, motors, rectifiers, oscillators, and magnetic amplifiers.

AS-7616 MAINTENANCE CRANE IMA TECHNICIAN (SHORE)

This NEC requires performance of intermediate-level maintenance on weight-handling

equipment, including the A/S32M-14 and A/S32M-17 maintenance cranes. Also, you must troubleshoot and repair electric and hydraulic lifting systems, mechanical drive systems, suspensions, and electric and hydraulic control circuits and components.

AS-7617 CRASH AND MATERIAL HANDLING TECHNICIAN (SEA)

To acquire this NEC, you must perform intermediate-level maintenance on crash and material handling equipment, including the A/S32P-25 fire-fighting truck, A/S32A-35/36 shipboard aircraft crash crane, and 6,000-, 15,000-, and 20,000-pound diesel forklifts. You must also troubleshoot and repair electrical and hydraulic lifting and drive systems, mechanical drive systems, suspensions, and electric and hydraulic control circuits and components.

AS-7618 AFLOAT SUPPORT EQUIPMENT TECHNICIAN

To acquire this NEC, you must perform on-equipment repair and intermediate-level maintenance on engines, drive trains, brakes, and steering systems installed in A/S32P-25 fire trucks and A/S32A-31A and A/S32A-32 aircraft tow tractors, including charging, starting, ignition, hydraulic, pneumatic systems, and their components.

Q1-3. What NEC requires performance of intermediate-level maintenance on aircraft jacks?

1. 7601
2. 7607
3. 7610
4. 7612

Q1-4. What NEC requires performance of intermediate-level maintenance on the A/S32M-17?

1. 7603
2. 7609
3. 7614
4. 7616

DUTY ASSIGNMENTS

LEARNING OBJECTIVE: Identify the types of duty assignments available to Aviation Support Equipment Technicians.

As petty officers, the AS technicians are usually assigned to activities that perform intermediate-level

maintenance. AS billets are assigned to all aircraft carriers. AS personnel assigned aboard carriers are usually attached to the Aircraft Intermediate Maintenance Department (AIMD).

Interesting overseas shore billets are offered to the AS. If third class petty officers are married, they may qualify for their dependents to accompany them to these overseas locations at Government expense. Shorter duty tours are usually standard procedure at overseas stations where dependents do not accompany the AS.

Between sea tours, the third class petty officer may be assigned to one of many naval air stations along the U.S. coasts. In addition, the Naval Air Maintenance Training Group (NAMTRAGRU) has a few naval air stations located inland where AS personnel may be assigned. AS personnel assigned to any one of these air stations are also usually attached to AIMDs.

Proper selection of assignments throughout your career is necessary for advancement to the senior paygrades. Selection boards look for well-rounded individuals that have performed in an exemplary manner in a variety of assignments, such as sea, shore, and overseas assignments. These positions include, but are not limited to, work center supervisor, leading petty officer (LPO), quality assurance representative (QAR), etc.

Although the AS community is small, it contributes to accomplishing the Navy's mission. The aircraft could not function without the equipment, expertise, and motivation of the AS technician. Without the assistance of the AS, the Navy's mission would be jeopardized.

Your job as an AS will range from simple tasks, such as changing oil in a tow tractor, to complex and difficult ones, such as isolating and repairing a defect on a gas turbine compressor. No job is too small; every task you perform helps the overall mission of the Navy.

Q1-5. AS personnel assigned aboard carriers are usually attached to what department?

1. Squadron
2. AIMD
3. Operations
4. V-1

Q1-6. Where are shorter duty tours usually standard procedures?

1. NAMTRAGRU
2. Unaccompanied overseas
3. Aircraft carrier
4. Overseas

MAINTENANCE

LEARNING OBJECTIVES: Identify the types of maintenance applicable to support equipment. Identify inspections applicable to support equipment. Recognize correct procedures for the removal and reinstallation of equipment.

The key to long-lasting equipment and mission readiness of support equipment is servicing and maintenance. Equipment failure easily delays a mission. This is especially true on board an aircraft carrier. With limited equipment on board and minimum manpower available, every effort must be made to maintain high availability of support equipment.

TYPES OF MAINTENANCE

No matter how well the support equipment is cared for, maintenance is still required to keep it in the best operating condition. The general maintenance skills and procedures are based on knowledge that is not contained in equipment manuals. These skills must be learned during on-the-job training.

The maintenance performed on the equipment falls into two broad categories: (1) actions taken to reduce or eliminate failure and prolong the useful life of the equipment, and (2) actions taken when a part or component has failed and the equipment is out of service. Therefore, the types of maintenance can be considered to be preventive maintenance (scheduled maintenance) and corrective maintenance (unscheduled maintenance).

Preventive Maintenance Inspections (PM)

In operation, support equipment is subjected to a variety of stresses, strains, and environments. If the equipment does not have the proper preventive maintenance, the equipment soon does not work. The equipment also needs to be inspected regularly, making sure any problems are corrected.

When equipment comes into the work center for inspection, it should be cleaned to ease the inspection. Cleaning electrical components consists of removing dust, grease, or other foreign matter from covers, chassis, and operating parts. The method used to clean different parts and units may vary, but usually a vacuum cleaner works to remove loose dust and foreign matter. To remove grease or other petroleum deposits, use a cloth moistened with dry-cleaning solvent. After

cleaning, wipe the part dry or allow it to air-dry before applying power.

As you clean the equipment, inspect it for loose leads, improper connections, and damaged or broken components. These inspection precautions are particularly applicable to new equipment, equipment returned from overhaul, equipment that has been preserved or stored for long periods of time, and equipment that has been exposed to the weather for long periods of time. A good, thorough, visual inspection will often reveal problems that can be corrected with a minimum amount of labor and parts. Such problems, if left uncorrected, might result in major repair costs.

INSPECTIONS.—Maintenance inspections for support equipment are established by the Naval Air Systems Command. These inspections specify the minimum requirements necessary to maintain the subject equipment. However, more detailed and frequent inspections could be established, depending on local conditions.

Types of inspections performed for the maintenance of support equipment are discussed in the following text.

Acceptance Inspections.—These inspections are performed at the time a reporting custodian accepts a newly assigned item of support equipment (SE). They include an inventory of all records and components that make up the item of support equipment, a configuration verification, a preoperational inspection as required by the applicable MRCs, and a functional test. The inventory will include current OPNAV 4790/51 History Card, Aeronautical Equipment Service Record (AESR), Maintenance Facility (MF), and Logbook and Inventory Record (LIR), or records applicable to the item of support equipment being received. The receiving activity is responsible for maintaining and updating these forms while it has custody of the equipment. If these forms or records are not received with an item of support equipment, the new reporting custodian should notify the previous reporting custodian and inform the Support Equipment Controlling Activity (SECA) and Naval Aviation Maintenance Office (NAMO). If forms or records cannot be obtained by this method, the new reporting custodian performs all PM inspections specified in the applicable MRCs and makes new records/forms, as applicable, for the item of support equipment received. If configuration verification is beyond I-level capability or if configuration cannot be determined, the item of SE

is returned to the appropriate Designated Rework Point (DRP) for verification. Activities that accept new items of support equipment must originate all records/forms. The activity receiving the item of support equipment may elect to increase the depth of inspection if the support equipment condition indicates such action is warranted.

Transfer Inspections.—These inspections are basically the same as acceptance inspections. They are accomplished by the reporting custodian when an item of support equipment is transferred on a permanent basis. They include an inventory of all components that make up the item of support equipment, verification of the configuration, a preoperational inspection as required by the applicable MRCs, and a functional test. The above inventory will include OPNAV 4790/51, AESR, LIRs, and other OPNAV forms, as applicable to the item of support equipment being transferred. The transferring activity is responsible for updating the applicable forms, and will take the necessary precautions to ensure that these updated forms are forwarded to the activity accepting the support equipment. The activity transferring the support equipment may elect to increase the depth of inspection if the support equipment condition indicates such action is warranted.

Preoperational Inspections.—Preoperational inspections are accomplished prior to the first use of the subject equipment for that day or prior to each use if specified by the MRC. This inspection is a combination of requirements for verification of satisfactory functioning and proper servicing prior to use. When completed, the preoperational inspections are signed off on the Support Equipment Preoperational Record to indicate that all requirements have been complied with. The record is located in the custodian's work center.

If the equipment is used more than once during the day, a brief inspection should be performed prior to each use. This inspection need not be as detailed as the preoperational inspection unless required by the MRC. The Support Equipment Preoperational Record should be checked to ensure that the preoperational inspection has been completed.

Postoperational Inspections.—Before securing (stopping) equipment, check for proper operation. After securing the equipment, make a visual inspection for condition, fuel level, oil level, water level, and so on; service if needed so that the equipment will be ready for the next use. Replace panels, covers, and so forth, to protect the equipment from the weather.

Calendar Inspections.—The calendar inspection was formerly known as a periodic inspection. On some of the older support equipment, these inspections are still referred to as periodic inspections.

Calendar inspections are overall examinations of specific equipment. The interval between inspections depends upon the type of equipment. The intervals may be in terms of days, weeks, months, hours, starts, and so forth, or some combination of these.

Special Inspections.—A special inspection depends upon occurrence of certain circumstances or conditions, or a maintenance action with a prescribed interval occurring more frequently than calendar inspections. Inspections required at intervals (such as 10 hours, 30 hours, and 7 days) are usually classified as special inspections. These inspections are done by the using activity if they are equipped to perform them. Otherwise, they are done by the activity having prime custody of the equipment.

NOTE: Support equipment is NEVER transferred in a nonoperational or incomplete status without prior approval of the cognizant SECA.

MAINTENANCE REQUIREMENTS CARDS (MRC).—Maintenance requirements cards (MRCs) are provided for each major type of support equipment. These cards provide the minimum requirements necessary to maintain the subject equipment in a satisfactory and effective operational readiness condition. These are 5 by 8 cards arranged by rating and work area to provide the most efficient sequence of accomplishment. Assembled into sets and numbered in sequence, the cards contain pertinent information required by each maintenance person to complete each task.

Individual sets of MRCs are prepared for preoperational and calendar (periodic) inspections.

- **Preoperational maintenance requirements cards** list those requirements necessary to be performed by the using activity.
- **Calendar maintenance requirements cards** list the responsibilities of the activity that has prime custody of the equipment.
- **Special maintenance requirements cards** are contained in the same set and have the same number as the preoperational MRCs. The special MRCs are marked as "Special" and are performed by the using activity if so equipped;

otherwise, they are performed by the activity that has prime custody of the equipment.

The MRCs that are available for support equipment are listed by publication number and title in the *Navy Stock List of Forms and Publications*, NAVSUP Publication 2002, section VIII, part C, and its supplements.

Corrective Maintenance

With the preventive maintenance program presently in effect, the need for corrective maintenance should be limited to only the corrective actions required by normal wear. However, this is not the case whenever unqualified or careless personnel operate the equipment. These two factors account for most of the corrective maintenance actions required.

You can do two things that should help solve these problems. First, become very knowledgeable on all the equipment assigned; second, take advantage of every situation where it is possible to teach others in the proper operation and care of the equipment.

When a malfunction does occur, the trouble must be located quickly and repairs made. Even a minor malfunction could progress to the point of being a safety hazard to personnel, equipment, and surrounding objects.

NOTE: Equipment that has a malfunction should be tagged to indicate the malfunction, and a VIDSMAF or NALCOMIS entry should be completed to document for repair action.

TROUBLESHOOTING.—Troubleshooting performed by a maintenance crew consists mainly of finding and correcting malfunctions that are found during operational checks and periodic inspections; also, those found during the checking of discrepancies after a piece of equipment has been used. Some troubles may be rather simple and obvious, while others may be complex and time-consuming. As you become familiar with the equipment and its normal operations, troubleshooting will become easier. Although experience and familiarity with the equipment are necessary, you must also use a systematic, logical approach to isolate troubles.

You should analyze the information at hand, such as the information obtained from the operational check or the information contained in the operator's discrepancy report.

By logical reasoning, you can then eliminate many of the system's components as possible sources of trouble. The trouble may be isolated to a particular component that can be replaced instead of blindly exchanging components in hopes of finding the trouble.

To become a good troubleshooter, you must use the various aids that are available. The wiring diagrams, functional drawings, and troubleshooting information contained in the proper equipment manual should be fully used. This information is especially useful in checking power distribution and other electrical circuits throughout the different systems of the equipment. Voltage and resistance charts are also a great aid when isolating a trouble to a particular part or subassembly. These are but a few of the aids to good troubleshooting. The ability of a troubleshooter depends upon his/her abilities in using the tools and information at hand.

The first logical step after the unit has been delivered to the shop, screened, and put into the repair channels is a visual check of the unit. It should be thoroughly inspected for broken leads, parts that are burned, loose mountings, proper fluid levels, and any other signs of failure. If no visual defects are found, operate the equipment, and observe for any signs of malfunction.

In the preliminary check, the experience of the technician is an important factor, and the knowledge gained from previous difficulties with the equipment often serves as a guide in knowing what to expect. The experienced and the inexperienced technicians can find assistance by consulting the service instruction manual for the equipment involved. These manuals often give detailed troubleshooting procedures for making the initial inspections.

PERFORMANCE TESTING.—It is necessary to make a check of the equipment's performance after each periodic inspection or corrective maintenance. The system performance check is a complete operational check of the system in all modes of operation. This check serves to determine if other malfunctions are present, and it allows evaluation of overall system performance.

FINAL CHECKS.—The final check consists of a complete and thorough inspection of all the components as well as replacement of all inspection panels, plates, and other equipment removed during the inspection or while performing maintenance. This includes the use of safety wire, stop nuts, and other means for securing equipment when needed.

The final checks also include removal and stowage of work stands, power vehicles, and other equipment. Collect, clean, account for, and stow all tools in their respective places. The last, but very important check to make, is the condition of the working area. Ensure all loose materials, such as nuts, bolts, washers, bits of safety wire, and other articles, are picked up and properly thrown away, and the working area is left in a clean condition.

NOTE: If an area is left cluttered and dirty after a job, it becomes a safety hazard to personnel and equipment. Personnel may fall, equipment may skid, or the litter may be picked up and ingested by jet engines. These engines are especially susceptible to foreign object damage (FOD).

EQUIPMENT REMOVAL, REPAIR, AND REINSTALLATION

Planning is the most important step in equipment removal and installation. You should be able to describe the steps in planning for equipment removal and installation. Planning must include such items as obtaining the proper tools, removing hazards to personnel and equipment, clearing shop space, and reinstallations prior to the actual removal. If these things are considered and plans are made accordingly, you are more likely to have no lost time, no personnel injuries, and no damaged equipment.

Removal Of Equipment

To remove a major unit for maintenance, periodic check, or lubrication, plan the removal carefully. The route the unit must take from its mounts to the shop space must be clear. This includes clearing bench space or other areas in the shop where the unit is to be placed.

The necessary and proper tools must be obtained. Wrenches, screwdrivers, pliers, and if the equipment is extremely heavy, a hoist, may be required. If help is needed, personnel must be obtained. The entire removal procedure must be thoroughly explained, letting each person know his/her specific job. The person in charge of the removal should issue all instructions timed so that the result is a smooth effective operation. The work should be done with caution to eliminate the possibility of injury to personnel or damage to the equipment. Observe all safety precautions.

NOTE: For specifics on procedures for use or care of hand tools, refer to the *Use and Care of Hand Tools and Measuring Tools*, NAVEDTRA 14256.

When the major unit is in the shop, certain precautions should be followed prior to disassembly or removal of assemblies or subassemblies. The outside of the unit should be cleaned, as discussed in the previous section. When the dust covers are removed, any gaskets in use should be inspected. If found damaged, new ones must be obtained.

Repair Of Equipment

Whenever the repair of assemblies or sub-assemblies is required, you must always ensure that you refer to the applicable maintenance instruction manual (MIM) for the equipment you are working on for proper procedures in repairing the item.

Reinstallation Of Equipment

Reinstallation is usually just the reverse of the removal procedure. Although installation procedures are listed in the appropriate equipment manual, this phase of the operation causes a great deal of trouble. Most of the troubles result from carelessness and oversight on the part of the technician. Specific instances are loose cable connections, switched cable terminals, improper or missing hardware, and loose fittings or leaks.

NOTE: Electrical connectors must be connected carefully to prevent bending or breaking the connecting points. Any positive locking device that is required, such as stop nuts, safety wire, cotter pins, must be installed.

MURPHY'S LAW

There is no doubt that you are familiar with Ohm's law. There is another law with which the technician may not be quite so familiar. This law, known as Murphy's law, states that "IF A PART CAN BE INSTALLED WRONG, NO MATTER HOW REMOTE THE POSSIBILITY, SOMEONE WILL INSTALL IT THAT WAY." To ignore this law can cause problems that range from embarrassment of the technician or actual destruction of equipment to injury or death to personnel. Each month the *Naval Aviation Safety Review* and *Approach* publications present the problems caused by maintenance personnel when Murphy's law was proven true. Danger areas you should watch for are installation of cable connector plugs on the wrong receptacles, crossing lines, installing tubes in the wrong sockets, and so on. The possibilities are endless, and a good maintenance technician must be constantly alert to the dangers.

Do not become victim to proving that Murphy's law is true.

Q1-7. What is the first thing you should do when a piece of support equipment comes in for inspection?

- 1. Inform your supervisor*
- 2. Change the oil*
- 3. Clean it*
- 4. Refer to Maintenance Requirements Cards*

Q1-8. What are the two types of maintenance?

- 1. Preventive & Corrective*
- 2. Preoperational & Postoperational*
- 3. Transfer & Acceptance*
- 4. Calendar & Special*

Q1-9. What type of inspection was formerly known as a periodic inspection?

- 1. Transfer*
- 2. Postoperational*
- 3. Preoperational*
- 4. Calendar*

Q1-10. When, if ever, can you transfer support equipment in a nonoperational or incomplete status?

- 1. Only with prior approval from the CO*
- 2. Only with prior approval from SECA*
- 3. Only with prior approval from the Department Head*
- 4. Never*

Q1-11. Which of the following troubleshooting aids are the most useful to you when troubleshooting an electrical malfunction?

- 1. Logic, supervisor, and peers*
- 2. Supervisor, preoperational inspection, and functional diagrams*
- 3. Logic and preoperational inspection*
- 4. Wiring diagrams, experience, MIM, and functional drawings*

EQUIPMENT SERVICING

LEARNING OBJECTIVES: Recognize proper procedures for servicing support equipment. Identify consumable materials used in servicing support equipment.

The life of support equipment depends upon proper care and servicing. Most of the service requirements are simple, but important. Servicing support equipment

includes refilling fuels, lubricants, coolants, hydraulic fluids, and other consumables (frequently used materials).

You should be able to identify the types of fuels and lubricants, their specific use, and the method and frequency of application. Proper selection of fuels is also important. You do not put diesel fuel in a gasoline engine or gasoline in a diesel engine. Yet, it frequently happens.

Perhaps you have seen what happens to the wheel bearings in an automobile when they were not properly lubricated. In some cases the bearings were damaged due to lack of grease or by use of the wrong type of grease. This type of damage can be avoided if the wheel bearings are inspected at regular intervals and if the correct lubricant is selected. Servicing modern support equipment is important. A good knowledge of correct fuels and lubricants makes the job easier and safer for the equipment.

SERVICING PROCEDURES

Usually, servicing support equipment is not very complicated, but it is extremely important. You should be able to determine how and why servicing can often be so critical. For example, one item of equipment may require several different types of oil, grease, or fluids. Selection of the correct types and proper application to the proper points can make the difference between a piece of equipment that gives excellent performance and one that is damaged beyond repair.

Complete servicing details can be found in the operation, servicing, and repair instructions section in the MIM written for that particular type and model of equipment. Servicing information can also be found in the MRCs (maintenance requirements cards).

CONSUMABLES

The following text discusses some of the fuels, lubricants, hydraulic fluids, and coolants used in support equipment.

Fuels

Fuels for gasoline and diesel engines are by-products of petroleum. Petroleum products include gasoline, kerosene, diesel fuel, lubricating oils, gear lubricants, and greases. Many different products are added to the raw by-products to obtain a fuel that can perform well in modern equipment.

Fuels may be polluted by dirt, rust, water, or by accidentally combining with other types of petroleum products. If the products are to serve the purposes for which they are intended, it is vital that you avoid such pollution. Dirt and water in fuels are primary causes of premature engine failure. When you handle fuels, cleanliness is essential.

GASOLINE.—Gasoline contains carbon and hydrogen in proportions that allow it to burn freely and produce heat energy. It evaporates (changes to a vapor) at any temperature. Because gasoline vapors are heavier than air, they sink to the ground (fig. 1-2). To decrease the fire hazard of having the gasoline vapors in a closed place where instant combustion could take place, the place in which gasoline is used **SHOULD BE THOROUGHLY VENTILATED THROUGH OPENINGS NEAR THE FLOOR.**

If all the potential heat energy contained in a gallon of gasoline could be turned into actual work, a motor vehicle could run many more miles on each gallon. However, only a small percentage of this heat energy is turned into power by the engine. Most authorities consider the power losses within the engine to be as follows:

<u>ENGINE</u>	<u>PERCENT OF POWER LOSS</u>
Cooling system	35
Exhaust gases	35
Engine friction	<u>5 to 10</u>
Total	75 to 80

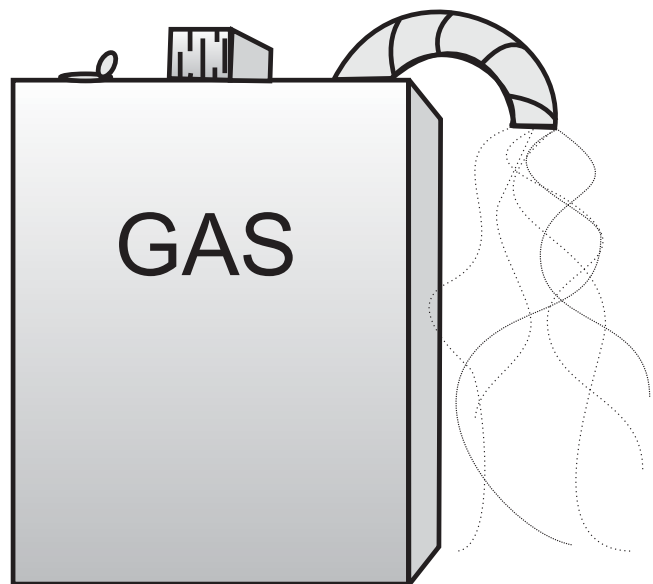

AS1f0102

Figure 1-2.—Silhouette of gas vapors falling. Caution: Gasoline vapors are heavier than air.

Every manufacturer recommends the octane rating of the gasoline considered best for the engines produced. In addition to engine design, factors like the weight of the vehicle, the ground and highways over which it is driven, and the climate and altitude of the locality also determine what gasoline is best to use. All other factors being equal, the following may be considered as some of the properties of the best gasoline:

- Good antiknock quality; a minimum content of foreign matter
- A volatility that makes starting easy, allows smooth acceleration, and costs less to operate

NOTE: The type of gasoline recommended by the manufacturer should always be used to ensure maximum performance.

DIESEL FUEL.—Diesel fuel is heavier than gasoline because it is taken from the residue of the crude oil after the more volatile (easily ignited) fuels have been removed. As with gasoline, the efficiency of a diesel fuel varies with the type of engine in which it is used. By distilling, cracking, and blending several oils, a suitable diesel fuel can be obtained for almost all engine operating conditions. Slow-speed diesels use a wide variety of heavy fuels; high-speed diesel engines require a lighter fuel. A poor or improper grade of fuel can cause hard starting, incomplete combustion, a smoky exhaust, and engine knocking.

The properties a manufacturer considers in specifying a fuel for a diesel engine are volatility, cleanliness, viscosity (consistency), ignition quality, and antiknock quality.

JET PROPULSION FUELS (JP).—More often, jet propulsion fuels (JP) are for use in jet engines. However, some types of jet fuels (such as JP-4 and JP-5) are well suited for use in modern, high-speed diesel engines, such as those used in support equipment. Most manufacturers specify diesel fuel (grade DF-1 or DF-2) or jet propulsion fuel (JP-5). The selection is dependent upon availability except in the case of a gas turbine power unit mounted on a tractor, which depends upon the tractor for its fuel supply. To meet the requirements of the gas turbine power unit, aviation jet fuel is the type of fuel that must be used. Aviation fuels are more useful than diesel fuels because they provide more power outlet per pound, fewer pollutants, increased engine life, and greater availability aboard naval air stations and aircraft carriers.

Lubricants

A lubricant (oil or grease) is a substance used to reduce friction by preventing direct contact of moving surfaces with each other. The lubricant is pressed into a thin film between moving parts, which rub on the film. The film of oil gives a slippery nature to surfaces. This film is constantly renewed by additional oil supplied from a pressure pump to replace oil forced out by movement of the engine parts. The effect is two sheets or layers of oil sliding over each other. Thus, friction between the two metal surfaces is reduced to a minimum.

In addition to reducing friction and wear, lubricants act as cooling agents, which absorb heat from the surfaces over which they are spread. This is very true of engine oil, which carries heat to the engine oil pan where it is cooled. On some engines the oil is circulated through a water-cooled oil cooler to further cool off the heat.

Lubricants are also used as sealing agents. They fill the tiny openings between moving parts, cushioning them against damage from extreme heat.

Lubricants also act as cleaning agents. Grit and dirt that get into engine parts are removed by the lubricants before damage results. Foreign matter found in old oils and greases in the bottom of the crankcase is evidence of the cleansing quality of lubricants. In addition, some lubricants have chemicals added to make them better cleaners.

OILS.—The high temperatures, speeds, and cylinder pressures of modern engines have made better grades of lubricating oils necessary. To increase efficiency, certain chemicals called "additives" are put into oils. Additives are resistive agents, which are used against oxidation and other kinds of metal decay. Oil that contains additives specifically designed to help clean the piston rings and other parts of the engine as it lubricates is known as "detergent oil."

Lubricating oils serve the following purposes:

- Prevent metal-to-metal contact in moving parts of mechanisms
- Help carry heat away from the engine
- Clean the engine parts as they are lubricated
- Form a seal between moving parts

Moving parts that do not have enough oil melt, fuse, or seize after a very short period of engine operation. All gears and accessory drives (as well as

other moving parts of the engine subject to friction) must be bathed in oil at all times.

GREASES.—Greases are compounds of oil and soap. The soaps used are not ordinary laundry soaps but animal fats mixed with certain chemicals. The main purpose of the soap is to provide a body or carrier for the oil that actually does the lubricating.

Grease is used where oil is impractical or unsatisfactory due to centrifugal force, load, temperature, or exposure. For instance, in wheel bearings, grease maintains a lubricating film under heavy loads and when the equipment is stationary for long periods of time.

Grease is separated into broad classifications, such as chassis, cup of water pump, wheel bearings, and general-purpose grease, and so on. Many special-purpose greases are manufactured. Among these are distributor cam lobe lubricant, electric motor bearing grease, and preservation grease.

CAUTION

Severe damage can result from too much or too little lubrication, as well as from the use of the wrong type of lubricant.

You must ensure that the proper grease is used for the job. For example, chassis grease used on a distributor cam lobe causes arcing and burning of the breaker points as the grease melts and is thrown onto the breaker points by centrifugal force. You can find information as to the proper grease to use in the lubrication charts for the unit being serviced.

Fluids

Fluid is the means by which energy is transmitted from the pump to the various units to be started. To operate efficiently in a system, a fluid must have certain properties and characteristics.

- It must flow freely at extremely high and low temperatures.
- It must be noncorrosive to metals and must not react chemically on the seals and packing used in the system.
- It must have good lubricating qualities and be nonflammable.

Fluids include brake fluid, hydraulic fluid, and automatic transmission fluid.

BRAKE FLUID.—Most hydraulic brake systems use a nonpetroleum-based hydraulic brake fluid, such as specification VV-H-910 or VV-B-680.

CAUTION

DO NOT mix petroleum-based or mineral-based hydraulic fluid (such as MIL-H-5606B) with synthetic-based brake fluid. Attempts to combine the two results in formation of a jelly substance, followed by decomposition of the natural rubber seals and system failure. Consult the lubrication chart for the particular unit before servicing any hydraulic system, and use only the fluid recommended by the manufacturer.

HYDRAULIC FLUID.—Hydraulic fluid is used in support equipment, such as hydraulic test stands, forklifts, aircraft jacks, and spotting dollies. Most hydraulic fluids are red in color and come in containers ranging from 1 quart to 55 gallons. Many types of hydraulic fluids are available. They can be synthetic-based or petroleum-based fluids. NEVER MIX THE TWO. Always refer to the manufacturer's recommendations before servicing any unit.

AUTOMATIC TRANSMISSION FLUID.—The majority of support equipment that have automatic transmissions are designed to use type A automatic transmission fluid. Also, this fluid is used in the majority of power steering systems. The correct fluid for your equipment is listed in the technical manual.

Coolants

Most multi-cylinder engines used in automotive and support equipment use a liquid cooling system. Any liquid used in this type of system is called a "coolant." Water and antifreeze solutions are used as coolants.

NOTE: Water used in radiators should be clean and should be checked often for cleanliness and quantity.

A vehicle operated in temperatures below 32°F requires an antifreeze solution in its cooling system. Without this solution, the water in the cooling system can freeze and cause extensive damage.

A good antifreeze solution mixes readily with water. Ethylene glycol (antifreeze compound) has an extremely high boiling point, is non-corrosive, has no odor, does not evaporate in use, and gives complete protection against freezing in normal use. It gives a maximum protection against freezing to -65°F when mixed to a solution of 60-percent solution with 40-percent water. Once mixed, the solution penetrates openings and connections more readily than plain water. Before the first filling of antifreeze and periodically thereafter, you should check the hoses for leaks. Most antifreeze compounds contain a rust and corrosion inhibitor. Without an inhibitor, rust and corrosion form in radiators, causing water-cooled engines to overheat.

NOTE: If the proportions of ethylene glycol are raised in the solution, it will result in a higher freezing point for the solution, consequently giving less protection. If 100-percent ethylene glycol were used, its freezing point would not be much below that of water.

All antifreeze solutions require periodic checks and must be replenished when tests show that they do not give the required protection against freezing. Hydrometers are used for such testing. (A hydrometer is an instrument used for determining the specific gravity of a liquid.)

Antifreeze solutions (even permanent types) are not recommended for use beyond one season. Furthermore, it is recommended that different types of antifreeze solutions not be mixed. When two types of solutions are mixed, there is no way of knowing the temperature at which the mixed solutions freeze. Also, their ingredients may react chemically, causing restrictions in the cooling system.

Q1-12. You need complete details for a specific type or model of aviation support equipment. You should use which of the following sources?

1. NA 17-1-125
2. Maintenance Instruction Manual (MIM) only
3. Maintenance Requirements Card (MRC) only
4. Maintenance Instruction Manual and Maintenance Requirements Card

Q1-13. What are the primary causes of premature engine failures in support equipment?

1. Improper preoperational inspections
2. Water in the oil
3. Dirt and water in fuels
4. Misuse/abuse by operator

Q1-14. Gasoline evaporates at which of the following temperatures?

1. Any temperature
2. Only below 32°F
3. Only above 32°F
4. Only above 212°F

Q1-15. Which of the following properties will a manufacturer consider in specifying a fuel for a diesel engine?

1. Antiknock only
2. Viscosity only
3. Volatility only
4. Antiknock, viscosity, and volatility

*Q1-16. Which of the following is **NOT** a reason for aviation fuels being more useful than diesel fuels in support equipment?*

1. Fewer pollutants
2. Lower cost per gallon
3. Increased engine life
4. Greater availability aboard ships and stations

Q1-17. What happens if you mix petroleum-based or mineral-based hydraulic fluid with synthetic-based brake fluid?

1. It forms a jelly-type substance
2. It forms a reddish brown tar-like substance
3. It forms an acidic substance
4. It forms a solid substance

Q1-18. What instrument is used for testing the specific gravity of antifreeze solutions in support equipment?

1. Micrometer
2. Specific gravity meter
3. Hydrometer
4. Antifreeze test kit

CORROSION CONTROL

LEARNING OBJECTIVES: Identify the causes of corrosion control. Identify procedures for corrosion control prevention. Identify corrosion control publications applicable to support equipment. Identify minimum requirements for corrosion control training.

The reliability and effectiveness of support equipment depend largely upon the structural soundness of the metals that make up their many parts.

One great threat to structural integrity of support equipment is metal corrosion. Support equipment may be used in a variety of climatic and atmospheric conditions, which range from the hot, dry desert to the hot, humid Tropics to the cold, Arctic regions. In addition, the equipment is most often used in a salt-filled atmosphere, such as coastal shore bases, on islands, and especially on aircraft carriers. Shipboard and coastal support equipments are subjected to the effect of sea winds that can carry 10 to 100 pounds of salt per cubic mile of air. These difficult environmental conditions vary the speed and intensity of metal corrosion.

SUPPORT EQUIPMENT CORROSION CONTROL

Corrosion reduces the strength of materials and the strength of joints between parts. Most equipment is designed with an extra margin of strength for safety. Corrosion can weaken the structure, thereby reducing or eliminating this safety factor. Replacement or reinforcement operations are costly, time-consuming, and reduce usage of the equipment. Severe corrosion can cause failure of parts or systems. Such malfunctions can cause an important item of equipment to become inoperative during very critical demands.

You must know and be able to apply the common types of corrosion prevention and moisture-protecting materials. To accomplish this, you must be familiar with the types and causes of corrosion, types and uses of cleaning materials, materials and procedures for preservation and depreservation, and the means for the detection of corrosion.

The problem of protection for support equipment during storage and shipment is threefold: (1) prevention of corrosion of the metal parts; (2) control of deterioration of nonmetallic materials; and (3) elimination of physical damage to the support equipment during handling. Of these three, corrosion of metals is the most difficult to control.

Under corrosive conditions, metals tend to lose their metallic characteristics because they are trying to revert to their natural state. In other words, corrosion reverses the refining processes that produce the metals from their original ores. The tendency to corrode differs greatly between various metals. For example, magnesium alloys are very difficult to protect compared to the relatively good corrosion-resistant copper alloys.

Corrosion is the deterioration of the metal by chemical or electrochemical process. In the direct chemical attack, the reaction that occurs is similar to acid applied to bare metal. The most familiar type of corrosion reaction is between metal and water and is electrochemical.

In the electrochemical attack, metals of different electrical potential are involved, and they need not be in direct contact. The electrically charged ions of one metal are exchanged with charged ions of the opposite metal through a conductor. This conductor is the chemical agent and is known as electrolyte. It could be moisture, dirt, collection of fluids, debris, or anything that will allow the flow of electrical ions.

There are many factors that effect the type, speed, and cause of corrosion. In the electrochemical attack, it is a more serious factor in wet, humid climates. Also, the salt of seawater and sea air is one of the greatest single accelerating causes. In hot or extremely cold climates, the corrosion process is increased. In cold climates, the cause is from melting snow or ice. In contrast, the hot, dry inland air vastly reduces the corrosion process.

Corrosion can be controlled by maintaining a dry environment through the use of suitable moisture barriers or drying agents. This is what is meant by the term *preservation*.

CORROSION PUBLICATIONS

The AS rating covers a vast amount of different types and models of support equipment; therefore, it only makes sense that you would use a variety of publications in the corrosion prevention and treatment process.

Support Equipment Corrosion Control Manual

Ground Support Equipment Cleaning and Corrosion Control, NAVAIR 17-1-125, is the current technical manual to be used in the prevention, detection, and repair of corrosion on ground support equipment. This publication takes precedence over any and all maintenance instruction manuals (MIMs) and service instruction manuals (SIMs) at both the organizational- and intermediate-level maintenance activities for methods of prevention, detection, and repair of corrosion. You still follow the maintenance and service manuals in conjunction with matters not pertaining to corrosion control.

You will find NAVAIR 17-1-125 very helpful because it spells out specifically which materials and procedures you are to use to clean up corrosion and restore the protective surface.

Other Sources of Information

One of the biggest problems in corrosion prevention and control is knowing what materials to use, where to find them, and their limitations. Materials used should be those covered and controlled by military specifications. Corrosion prevention and control information pertaining to materials, methods, and techniques is scattered throughout many directives and instructions. The following is a list of sources of information that should be used as a reference in every unit's technical library and support equipment shop. Although these publications are intended primarily for corrosion prevention and control on aircraft and weapons systems, most of the information can also be used for aviation support equipment.

OPNAVINST 4790.2	<i>Naval Aviation Maintenance Program (NAMPP)</i>
NAVAIR 01-1A-509	<i>Aircraft Weapons Systems Cleaning and Corrosion Control</i>
NAVAIR 01-1A-518	<i>Corrosion Prevention Compounds for Protection of Naval Weapons Systems</i>
NAVAIR 07-1-503	<i>Cleaning Materials for Naval Weapons Systems Maintenance and Overhaul Operations</i>
NAVAIR 16-1-540	<i>Avionics Cleaning and Corrosion Prevention/Control</i>
NAVAIR 17-1-125	<i>Ground Support Equipment Cleaning and Corrosion Control</i>

TRAINING

Personnel engaged in support equipment maintenance must complete one of the following courses in corrosion control, as required by the NAMPP (*Naval Aviation Maintenance Program*):

- Successful completion of the NAMTRAGRU Corrosion Control (Basic) (C-600-3180) or Avionics Corrosion Control (C-100-4176).

- Successful completion of the NAESU equivalent training.
- Aviation rating specific "A" school (after 1 April 1992).

The requirement for *supervisors* in the I-level work center 92D is one of the above courses in addition to one of the following:

- Successful completion of Aircraft Corrosion Control Course (N-701-0013).
- Successful completion of Aircraft Corrosion Course (Course C-600-3183).

Individuals actually painting aircraft or support equipment must complete the Aircraft Paint Touch Up and Markings Course (Course N-701-0014) or Aircraft Paint/Finish Course (Course C-600-3182) prior to painting any equipment. This qualification is valid for an unlimited period.

The publications described in this manual are subject to periodic revision. Some are changed at regular intervals; others are changed as the need arises. When using any publication, be sure that you have the latest edition. When using a publication that is kept current by changes, make sure that you have a copy with the latest changes incorporated.

Q1-19. Which of the following statements defines corrosion?

1. Deterioration of metal by chemical or electrochemical process
2. Reaction of metals to electrical current
3. Deterioration of metal by cleaning agents
4. Reaction of metals to long-term storage

Q1-20. In the electrochemical attack of corrosion, which of the following climates is a more serious factor?

1. Cold
2. Hot and dry
3. Wet and humid
4. Cold and damp

Q1-21. What is meant by the term "preservation"?

1. Maintaining cleanliness in support equipment spaces
2. Performing preventive maintenance (PM) on equipment
3. Maintaining a dry environment around support equipment
4. Performing wash/wipe downs on support equipment

Q1-22. What is the primary technical manual you should use in the prevention, detection, and repair of corrosion on support equipment?

1. NA 01-1A-509
2. NA 17-1-125
3. NA 16-1-540
4. NA 01-1A-518

Q1-23. Which, if any, of the following publications take precedence over any and all publications when pertaining to support equipment corrosion control?

1. NA 01-1A-509
2. OPNAVINST 4790.2
3. MIMs for the specific equipment
4. None of the above

Q1-24. What training must all personnel complete prior to engaging in support equipment maintenance?

1. Successful completion of the NAMTRAGRU Basic Corrosion Control (C-600-3180) or Avionics Corrosion Control (C-100-4176)
2. Successful completion of Aircraft Corrosion Control Course (N-701-0013)
3. Successful completion of Aircraft Corrosion Course (Course C-600-3183)
4. Successful completion of Aircraft Paint and Touch Up Course (C-701-0014)

SUPPORT EQUIPMENT STANDARDIZATION SYSTEM (SESS)

LEARNING OBJECTIVE: Identify the purpose of Support Equipment Standardization System (SESS).

The Support Equipment Standardization System (SESS) is a computer-based asset control system that tracks inventory of support equipment. SESS, used in conjunction with NALCOMIS, provides an electronic method for scheduling periodic maintenance, subcustody management, technical directive accounting, and inventory management. The *SESS User's Guide* provides detailed information on SESS.

NOTE: When the SESS asset control system is not available, the Support Equipment Transaction Report, OPNAV 4790/64, is used to record support equipment issue and receipt transactions.

Q1-25. What is the primary purpose of SESS?

1. Automatically annotates history card
2. Tracks inventory of support equipment
3. Manages subcustody
4. Accounts for technical directive compliance

SUPPORT EQUIPMENT ISSUE/RECEIPT

LEARNING OBJECTIVE: Identify proper support equipment issue and receipt procedures.

Now that the maintenance action and the paperwork are completed, all you have to do is issue the piece of equipment to the squadron. The following procedures must be used to issue or receive support equipment on a subcustody basis:

- **Issue procedures.** All personnel must have in their possession a valid USN Aviation Support Equipment Operator's license (OPNAV 4790/102) for specific equipment being checked out. Prior to issue, a joint preoperational inspection will be performed by the issuing and the receiving personnel using the applicable preoperational inspection card. Personnel receiving the support equipment will sign the Support Equipment Preoperational Record (OPNAV 4790/52) in the Inspector's block. Issuing personnel will sign the Supervisor's block. The preoperational record will accompany each item of support equipment. The Support Equipment Transaction Report (OPNAV 4790/64), also known as the TR, will be signed in block 27f by the user to document support equipment issue. The white, green, and yellow copies of the TR will be retained by the issuing activity for local record-keeping purposes. The pink copy will be retained by the using activity for its records.

- **Receipt procedures.** All personnel must have in their possession a valid USN Aviation Support Equipment Operator's license for specific equipment being checked in. The Preoperational Inspection Record must be returned with the support equipment. A joint (issuing and receiving personnel) preoperational inspection will be performed. The Support Equipment Preoperational Record will be annotated the same as for issue procedures. The TR will be signed in block 28f by receiving personnel to document support equipment return.

- **Discrepancy identification.** All discrepancies noted during issue/receipt preoperational inspections

must be annotated on a VIDS/MAF by production control.

Q1-26. When issuing a tow tractor to the squadron, what must the person checking out the tractor have in his possession?

1. *Preoperational card*
2. *SE Operator's license (OPNAV 4790/102) for the specific equipment*
3. *Operators manual*
4. *MRC*

Q1-27. Who retains the pink copy of the Support Equipment Transaction Report?

1. *The issuing activity*
2. *The person checking the equipment out*
3. *The using activity*
4. *Maintenance personnel*

Q1-28. What document must accompany the equipment upon return to the support equipment shop?

1. *VIDS/MAF*
2. *Operator's manual*
3. *MRC*
4. *Preoperational inspection record*

Q1-29. All discrepancies noted on preoperational inspections must be annotated on what form?

1. *VIDS/MAF*
2. *History record*
3. *MRC*
4. *Preoperational card*

AVIATION SUPPORT EQUIPMENT

LEARNING OBJECTIVE: Describe types of support equipment maintained by Aviation Support Equipment Technicians.

Many different types of support equipment are needed to perform all the functions necessary to keep an aircraft in top condition. Most of today's equipment is used in the direct support of the aircraft itself. Aboard aircraft carriers, the principal users of support equipment are aircraft squadrons and the air department. Within the air department, flight deck and hangar deck aircraft-handling crews use aircraft-handling equipment, such as tow tractors and tow bars. In addition, aircraft crash, fire, and rescue crews use equipment such as the A/S32P-25 fire-fighting truck. These users depend upon personnel of the AS rating, who are normally assigned to

intermediate maintenance activities, for the maintenance of this equipment.

Since the squadrons and air department personnel are the principal users, the equipment is operated by personnel of ratings other than the AS. In addition, these personnel frequently accomplish servicing and preoperational inspections. Personnel of the AS rating are concerned primarily with major inspections and repair. However, this does not mean that you are relieved of all responsibilities concerning the operation and servicing of the equipment. To effectively perform all phases of maintenance—inspecting, troubleshooting, repairing, and testing—you must understand the operation of the equipment. This is especially important when troubleshooting and testing the equipment.

Many types of support equipment require licensed operators. Selected personnel of the AS rating are responsible for the formal training and licensing of these operators. You, the AS, may be called upon to instruct user activity personnel in the proper servicing and operation of certain types of equipment that do not require an operator's license.

The current edition of OPNAVINST 4790.2 defines support equipment (SE) as "all equipment required on the ground to make an aeronautical system, system command and control system, support system, subsystem, or end item of equipment operational in its intended environment." This is primarily the equipment covered by the Aircraft Maintenance and Material Readiness List (AMMRL) program.

Support equipment is classified into four major types: common (general purpose), peculiar (special purpose), standard (has government-approved specifications/drawings), and developmental (no government-approved specifications/drawings). It is further divided into the categories of avionics SE and nonavionics SE.

AVIONIC SE

Avionics SE (common and peculiar) includes all equipment of an electronics nature used for, but not limited to, the test, troubleshooting, alignment, or calibration of aircraft systems or components. Examples of avionics SE include general-purpose electronic test equipment (GPETE), automatic test equipment (ATE), vacuum pressure testers, and temperature and fuel quantity indicator test sets.

NONAVIONIC SE

Nonavionic SE (common and peculiar) includes all equipment that is nonelectronic in nature and may be powered or nonpowered. As an Aviation Support Equipment Technician, you will be required to maintain this equipment. Examples of power equipment are as follows:

- Mobile electric power plants; for example, the NC-10C
- Gas turbine-powered service equipment; for example, the NCPP-105
- Aircraft tow tractors; for example, the A/S32A-31A
- Mobile air-conditioners; for example, the A/M32C-17

Examples of nonpowered SE are as follows:

- Aircraft jacks
- Aircraft tow bars; for example, the NT-4
- Maintenance work stands; for example, the B-4

Q1-30. Who are the principal users of support equipment aboard aircraft carriers?

1. SE technicians
2. Air traffic controllers
3. Squadrons
4. AIMD personnel

Q1-31. An AS maintains which of the following categories of support equipment?

1. Avionic SE
2. Peculiar SE only
3. Common SE only
4. Common and peculiar nonavionic SE

IDENTIFICATION OF SUPPORT EQUIPMENT

LEARNING OBJECTIVE: Identify different types of support equipment by the equipment identification codes.

In the past, identifying support equipment was difficult because there were no standard naming conventions. An AS learned the designations and application of the equipment by association. That has changed somewhat. Now, newly constructed and modified support equipment are identified according to Military Standard 875A (MIL-STD-875A), which outlines the type designation system for aeronautical and support equipment. Table 1-1 is taken from

Table 1-1.—Equipment Identification Codes

EQUIPMENT IDENTIFICATION CODES			Miscellaneous Identification
INSTALLATION (1st Indicator)	TYPE OF EQUIPMENT (2nd Indicator)	PURPOSE (3rd Indicator)	
A - Aircraft or Missile Installed in or on vehicle, nonmission expendable)	22 - Apparel	A - Aircraft or Missile Support B - Bombing or Fire Control or Both (Nonelectronic)	T - Training (V) - Variable Configuration
	23 - Chemical		
	24 - Electrical		
	25 - Explosive		
	26 - Gaseous		
B - Aircraft or Missile (Transported, but not installed in or on vehicle, mission expendable)	27 - Hydraulic	C - Air Conditioning	
	28 - Materials, Pliable (fabric, rubber, etc.)	D - Detection	
	29 - Materials, Rigid (metals, wood, etc.)		

Table 1-1.—Equipment Identification Codes—Continued

EQUIPMENT IDENTIFICATION CODES			Miscellaneous Identification
INSTALLATION (1st Indicator)	TYPE OF EQUIPMENT (2nd Indicator)	PURPOSE (3rd Indicator)	
C - Combination (Ground and air-borne)	32 - Mechanical	E - Destruction	
	33 - Nuclear		
E - Ground, Not fixed	34 - Pneumatic	G - Flight Control or Navigation or Both (Nonelectronic)	
	35 - Optical		
F - Ground, Fixed	36 - Optomechanical	H - Aircraft Loading and Cargo Handling	
	37 - Electromechanical		
M - Ground, Self-contained (Movable, includes vehicle but not self-propelled)	38 - Invisible Light (Infrared)	J - Indicating	
	39 - Inertial	K - Aerial Stores (Munitions) Handling	
	42 - Electrohydraulic		
	43 - Manual		
N - Aircraft or Missile (Transported, but not installed in or on vehicle, nonmis- sion expendable)	44 - Internal Combustion	L - Lubricating	
	45 - Biological	M - Maintenance, Aircraft	
	46 - Pneumatic-Hydraulic	P - Protection	
	47 - Electropneumatic		
	48 - Hydromechanical		
P - Personal Use (Held or worn by individual)	49 - Gunnery	Q - Reconnaissance (Nonelectronic)	
	82 - Mobile Deployment (Bare Base) – Misc		
S - Ground, Self-propelled (Includes vehicle)	83 - Mobile Deployment (Bare Base) – Medical including dental, surgical, x-ray, etc.	R – Fueling S - Personnel Support	
U - Multi-installation	84 - Mobile Deployment (Bare Base) – Billeting/Admin	T - Testing	
W - Water (Surface or submerged)	85 - Mobile Deployment (Bare Base) Shop facilities - all types except electronics	U - Special, Not Otherwise Covered, or Combination of Purposes	
	86 - Mobile Deployment (Bare Base) – Food servicing including kitchen, dining, etc.	V - Maintenance, Automotive W - Graphic Arts X - Identification	
	99 - Miscellaneous	Y - Dissemination	

MIL-STD-875A, and it lists the codes used to create the equipment designators.

The new designations will be the same throughout the military services. However, present equipment with old designations will remain unchanged; they will not be redesignated unless they undergo an alteration or modification. This will make things easier for administrative purposes. An example of how a tow tractor's designator is derived can be seen in table 1-2.

Table 1-2.—Equipment Type Designator For The A/S32A-31A Tow Tractor

CODE	DESCRIPTION
A/	Aero/Support Equipment
S	Ground Self-Propelled
32	Mechanical
A	Aircraft or Missile Support
-31	The 31st piece of equipment in the 32A category to which a type designation has been assigned.
A	The first modification to the "-31" tractor

Q1-32. What does the 27 represent in A/M27T-5?

1. Hydraulic
2. Electrohydraulic
3. Pneumatic
4. Electrical

COMMONLY USED SUPPORT EQUIPMENT

LEARNING OBJECTIVE: Identify the operating characteristics of various types of commonly used support equipment.

As an Aviation Support Equipment Technician, you will find many different types of support equipment that you will have to maintain. This equipment falls into four basic categories: electrical, hydraulic, mechanical, and pneumatic. In the following paragraphs, you will get only a basic description of only a few items of the most commonly used support equipment.

MOBILE ELECTRIC POWER PLANTS (MEPP)

There are many types and models of mobile electric power plants (MEPP) in use in naval aviation. Their

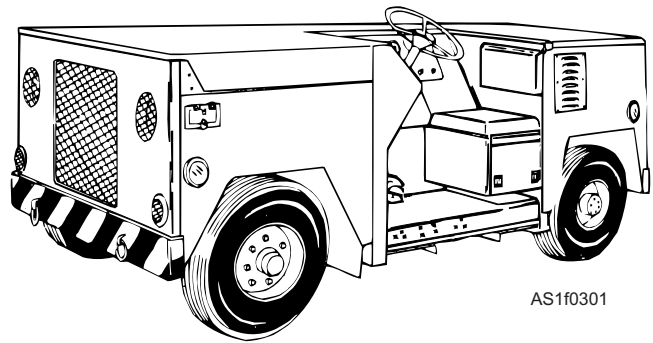

AS1f0301

Figure 1-3.—NC-8A/A-1 mobile electric power plant.

purpose is to provide ac and dc electrical power for servicing, starting, and maintenance of aircraft. Some are diesel engine powered, and some are electrically (externally) powered. Some of these are driven and some of them must be towed.

Personnel in the AS rating are required to become familiar with and maintain, mobile electric power plants.

NC-8A/A-1 Mobile Electric Power Plant

The NC-8A/A-1 (fig. 1-3) is a four-wheel, self-propelled, rear-wheel-drive vehicle, powered by a 4-cylinder, two-stroke-cycle Detroit Diesel engine. It provides 115/200-volt, 3-phase, 400-Hz, 60-kVA ac power, and 28-volt dc power at 500 amperes continuous, 750 amperes intermittently. This unit is used primarily at shore stations.

NC-10C Mobile Electric Power Plant

The NC-10C (fig. 1-4) is a four-wheel, trailer-mounted, electrical generating system, powered by a 6-cylinder, two-stroke-cycle Detroit Diesel engine.

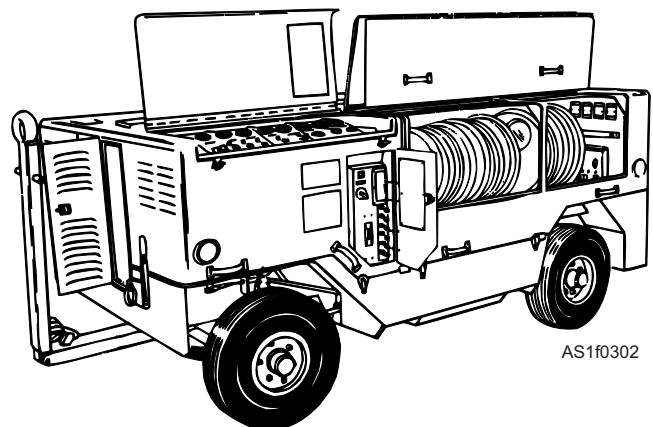

AS1f0302

Figure 1-4.—NC-10C mobile electric power plant.

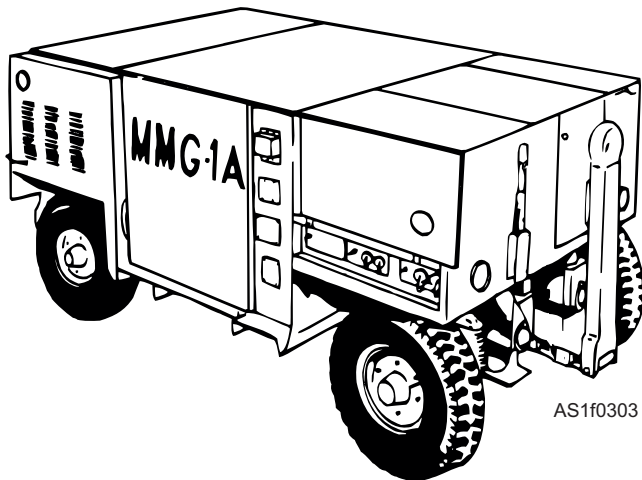

Figure 1-5.—MMG-1A mobile electric power plant.

It is not self-propelled and must be towed or manually moved. It provides 115/200-volt, 3-phase, 400-Hz, 90 kVA ac power, and 28-volt dc power at 750 amperes continuous, 1,000 amperes intermittently. This unit is used primarily at shore stations.

MMG-1A Mobile Electric Power Plant

The MMG-1A (fig. 1-5) is a small, compact, trailer-mounted, electric motor-driven generator set. It is not self-propelled and must be towed or manually moved. It is powered by a 3-phase, 60-Hz, 220- or 440-volt ac external power source. It provides 115/200-volt, 3-phase, 400-Hz, 60 kVA ac power, and 28-volt dc power at 500 amperes continuous, 1,000 amperes intermittently. This unit is used both aboard ship and at shore stations.

A/S37A-3 Shipboard Mobile Electric Power Plant

The A/S37A-3 (fig. 1-6) is a four-wheel, self-propelled, rear-wheel-drive vehicle powered by a 3-53 series, two-cycle Detroit Diesel engine. The engine drives the electric generator and the hydraulic propulsion system. The generator provides 115/200-volt, 3-phase, 400-Hz, 45 kVA ac power, and 28-volt dc power at 1,000 amperes. This unit is used primarily aboard ship.

Dummy Load Electric, DA-675/MSM

The dummy load electric unit, DA-675/MSM, often referred to as a load bank (fig. 1-7), is a four-wheel, trailer-mounted, electrical dummy load. It is not self-propelled and must be towed or manually moved. It is used at intermediate maintenance facilities

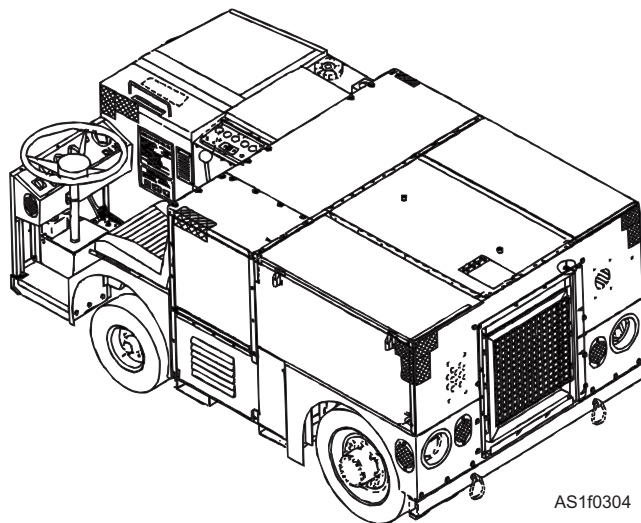

Figure 1-6.—A/S37A-3 shipboard mobile electric power plant.

to test the output power characteristics of 28-volt dc and 115/200-volt ac, 3-phase, four-wire, 400-Hz mobile electric power plants or motor generator sets. This unit is used both aboard ship and at shore stations.

Q1-33. The NC-8A/A-1 is powered by a 4-cylinder, two-stroke-cycle Detroit Diesel engine.

1. True
2. False

Q1-34. Which of the following mobile electric power plants has a 90 kVA generator?

1. NC-8A/A1
2. NC-10C
3. MMG-1A
4. A/S37A-3

Q1-35. Which of the following mobile electric power plants are used aboard ship?

1. MMG-1A and A/S37A-3
2. NC-8A/A1 and NC-10C
3. MMG-1A and NC-10C
4. NC-10C and DA-675/MSM

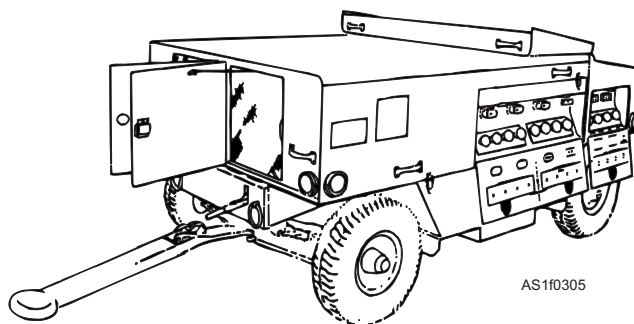

Figure 1-7.—DA-675/MSM dummy load electric unit.

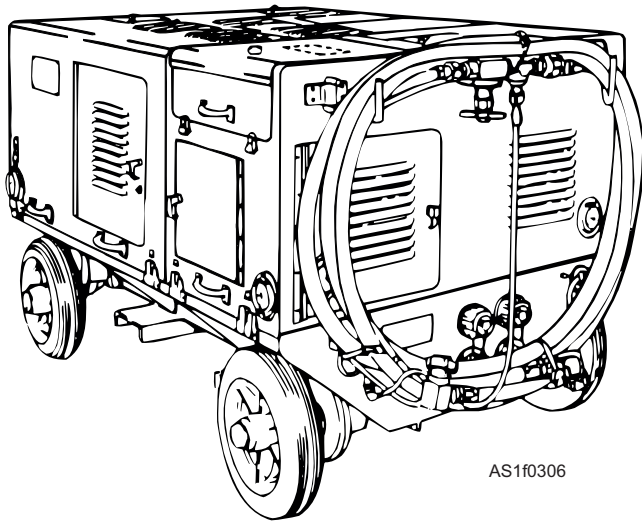

Figure 1-8.—A/M27T-5 portable hydraulic power supply.

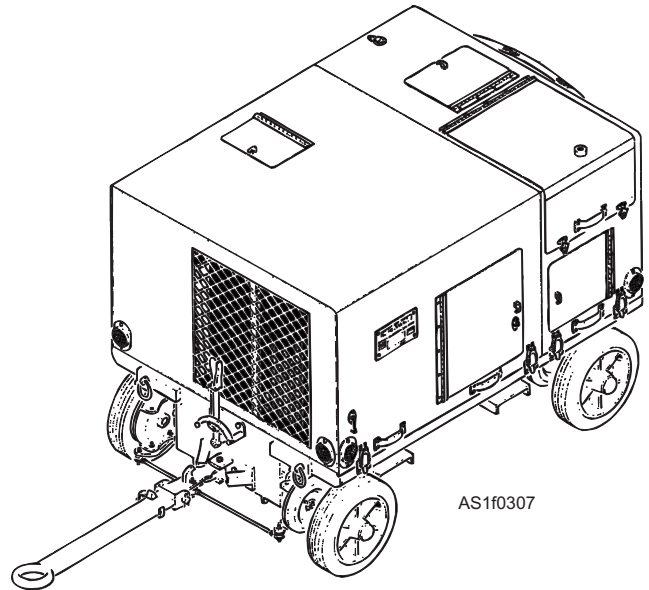

Figure 1-9.—A/M27T-7 portable hydraulic power supply.

HYDRAULIC SERVICING UNITS

There are many types and models of hydraulic servicing units used in naval aviation. The purpose of these units is to check, test, and service aircraft hydraulic systems. Some of the servicing equipment can be hand-carried; some will be moved manually; and some will have to be towed.

A/M27T-5 Portable Hydraulic Power Supply

The A/M27T-5 Portable Hydraulic Power Supply (fig. 1-8) is a single system hydraulic pumping unit with a rated capacity of 20 gpm (gallons per minute) at 5,000 psi. It is a self-contained unit designed to check performance and operating characteristics of aircraft hydraulic systems. It is powered by a three-cylinder, two-stroke-cycle diesel engine. The A/M27T-5 is capable of delivering hydraulic fluid at controlled pressures to operate aircraft hydraulic systems without the necessity of starting the aircraft engine.

A/M27T-7 Portable Hydraulic Power Supply

The A/M27T-7 (fig. 1-9) is similar in operation to the A/M27T-5 except for its source of power. The A/M27T-7 is powered by a 50-hp electric motor. A 50-foot power cable is provided for connection to a 440-volt, 3-phase, 60-Hz external power source. This unit can also be set up to run on a 220-volt source.

A/M27M-10 Hydraulic Fluid Dispensing Unit

The A/M27M-10 Hydraulic Fluid Dispensing Unit (fig. 1-10) provides a means of dispensing hydraulic fluid from a 55-gallon drum to any other container designed for use as a storage source, reservoir, or portable dispensing unit. It has four wheels with manual brakes on the rear wheels and is equipped with a means of lifting, inverting, and dispensing the hydraulic fluid through the use of a hand or air motor-driven pump.

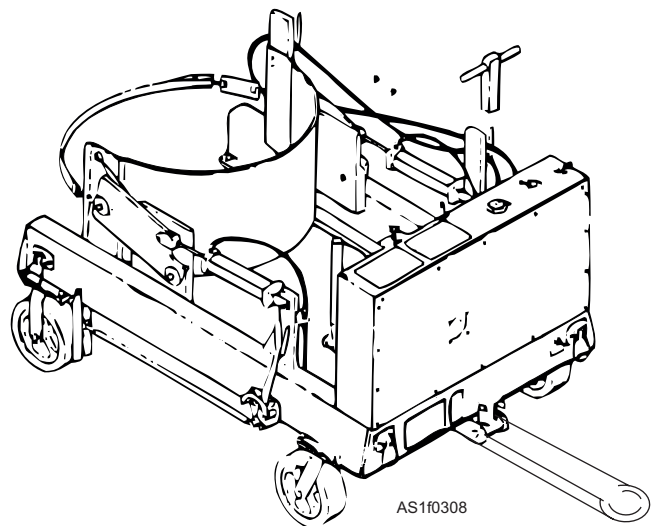

Figure 1-10.—A/M27M-10 hydraulic fluid dispensing unit.

HSU-1 Hydraulic Fluid Servicing Unit

The HSU-1 Hydraulic Fluid Servicing Unit (fig. 1-11) is a portable, hand pump operated, hand-carried unit, which is used for servicing main hydraulic systems, subsystems, bleeding brakes, flushing, and priming system components. It has a fluid holding capacity of 3 gallons, accepts a standard 1-gallon container, and uses it as a fluid reservoir. It also contains an integral 2-gallon reservoir. The unit is made of cast aluminum and has a sight gauge on the side to view the total contents within the holding reservoir.

H-250-1 Hydraulic Fill Unit

The H-250-1 Hydraulic Fill Unit (fig. 1-12) is similar in operation to the HSU-1. It is designed to use the standard 1-gallon can of hydraulic fluid and to dispense it, contamination free, to the aircraft systems. This is done by pumping the fluid from the original can, which is sealed into the unit and acts as the reservoir, directly to the aircraft. It is a portable, hand-pump operated, hand-carried unit.

Q1-36. Which of the following portable hydraulic power supply units is powered by an external power source?

1. HSU-1
2. A/M27M-10
3. A/M27T-5
4. A/M27T-7

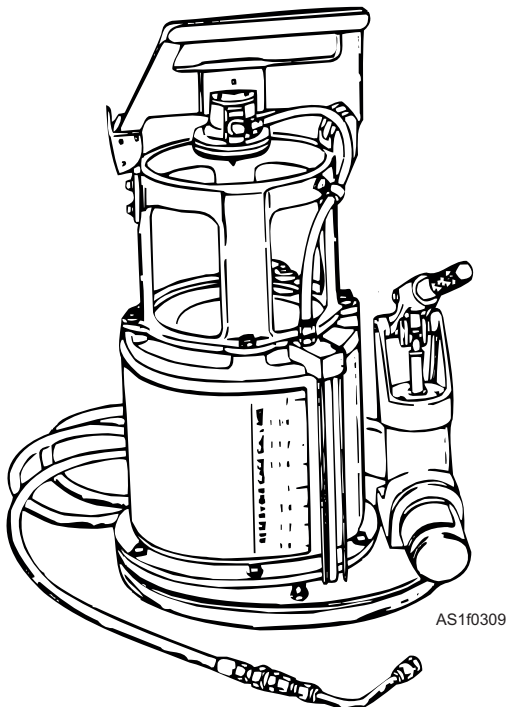

Figure 1-11.—HSU-1 hydraulic fluid servicing unit.

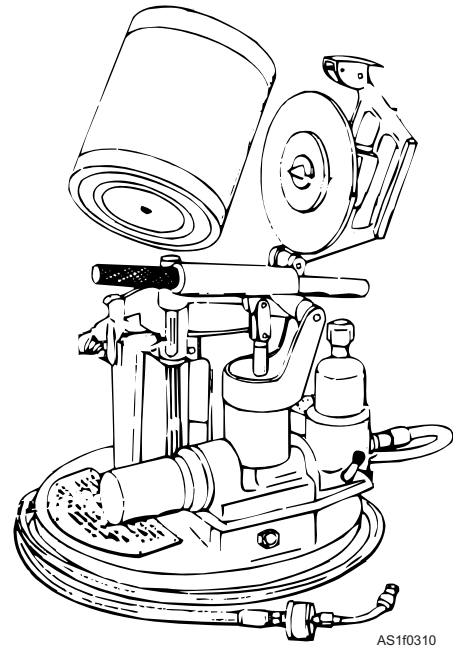

Figure 1-12.—H-250-1 hydraulic fill unit.

Q1-37. Which of the following hydraulic units uses a 55-gallon drum of hydraulic fluid?

1. A/M27T-5
2. HSU-1
3. A/M27M-10
4. H-250-1

AIRCRAFT TOWING EQUIPMENT

The tow tractor is the only safe means of moving the majority of today's aircraft. They are also used to move support equipment specifically equipped to be towed, such as mobile electric power plants, portable hydraulic power supplies, maintenance stands, etc. These are the only authorized uses for tow tractors.

As a rule of thumb, maximum aircraft weight that a tow tractor can handle is 10 times the drawbar pull of the tractor. In other words, a tractor that has a drawbar pull of 7,500 pounds is capable of towing an aircraft that weighs 75,000 pounds.

A/S32A-37 Tow Tractor

The A/S32A-37 Tow Tractor (fig. 1-13) is also known as the TA-35. It is a six-cylinder diesel engine powered, four-wheel drive tractor used for moving heavy shore-based aircraft. The automatic transmission has six forward speeds and three reverse speeds. This tractor can be configured as a Class I or Class II, and can tow aircraft weighing up to 200,000 and 350,000 pounds, respectively.

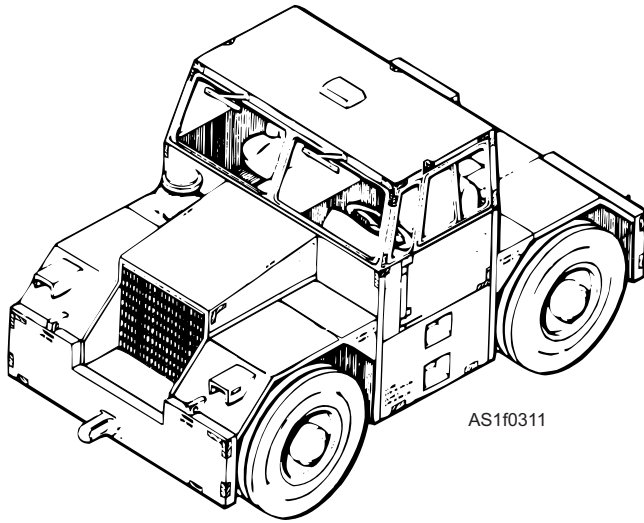

Figure 1-13.—A/S32A-37 aircraft towing tractor.

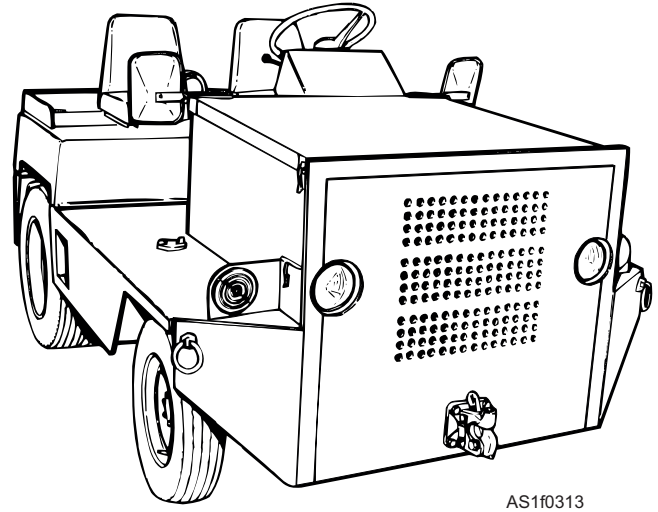

Figure 1-15.—A/S32A-30 aircraft towing tractor.

A/S32A-31A Tow Tractor

The A/S32A-31A tow tractor (fig. 1-14) is designed for towing shipboard aircraft. It has a 3-cylinder diesel engine, automatic transmission, a rear drive axle with dual rear wheels, and a drawbar pull of 8,500 pounds. The service brakes are hydraulically operated wet disc brakes, and are contained within the wheel ends of the rear axle. The front wheel steering is power assisted. This tractor is equipped for mounting a gas turbine compressor on the rear, and it draws fuel from the tractor's tanks.

A/S32A-30 Tow Tractor

The A/S32A-30 tow tractor (fig. 1-15), also known as the JG40, is used primarily to tow support equipment. It is capable of towing up to 40,000 pounds; therefore, its secondary mission is towing light aircraft and helicopters. This tractor has a 6-cylinder gasoline engine, three-speed automatic transmission, hydraulic

disc brakes on the rear wheels, and front wheel power-assisted steering.

A/S32A-30A Tow Tractor

The A/S32A-30A tow tractor (fig. 1-16) is used primarily to tow support equipment. It is capable of towing up to 40,000 pounds; therefore, its secondary mission is towing light aircraft and helicopters. This tractor has a 4-cylinder diesel engine, three-speed automatic transmission, hydraulically actuated front disc brakes, drum rear brakes, and front wheel, power-assisted steering.

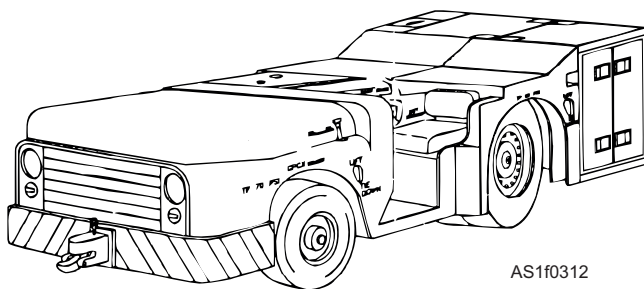

Figure 1-14.—A/S32A-31A aircraft towing tractor.

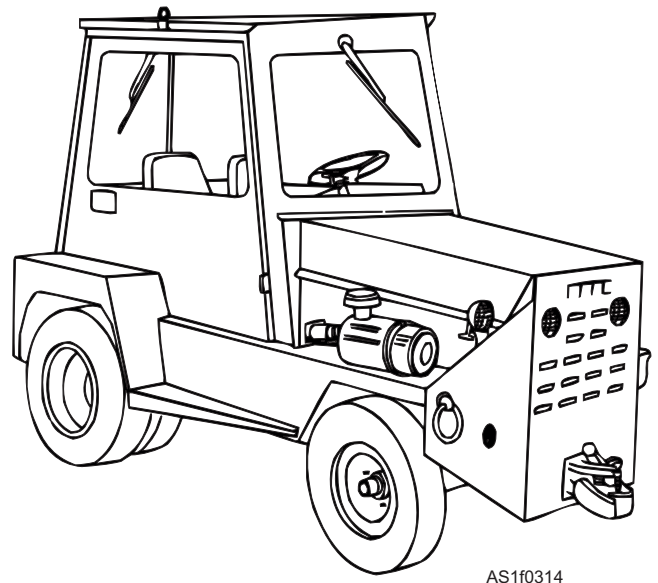

Figure 1-16.—A/S32A-30A aircraft towing tractor.



AS1f0315

Figure 1-17.—A/S32A-42 aircraft towing tractor.

A/S32A-42 Tow Tractor

The A/S32A-42 tow tractor (fig. 1-17) is designed for towing shore-based aircraft weighing up to 100,000 pounds. It has a 4-cylinder diesel engine, 3-speed automatic transmission, hydraulically actuated front disc brakes, drum rear brakes, and front wheel power-assisted steering.

A/S32A-32 Tow Tractor

The A/S32A-32 tow tractor (fig. 1-18) is more commonly referred to as a “spotting dolly.” It is designed to tow, turn, and position aircraft within the confines of a ship’s hangar deck. It has a 3-cylinder Detroit diesel engine that drives two main hydraulic pumps. Although a single joystick controls it, each wheel can rotate independently, which enables the tractor to pivot around its center with a minimal turning radius. It has a drawbar pull of 14,000 pounds and a lift capability of 16,000 pounds.

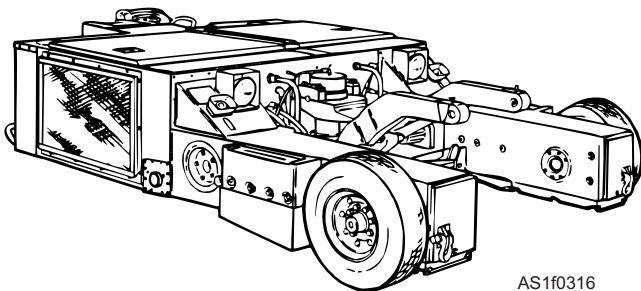

AS1f0316

Figure 1-18.—A/S32A-32 aircraft towing tractor.

Q1-38. If a tractor has a drawbar pull of 8,500 pounds, what is the maximum aircraft weight it can tow?

1. 18,500
2. 85,000
3. 185,000
4. 850,000

Q1-39. Which of the following tractors is also called a “spotting dolly”?

1. A/S32A-30
2. A/S32A-30A
3. A/S32A-32
4. A/S32A-37

JET AIRCRAFT START UNITS

The aircraft start unit is designed to provide air for starting aircraft jet engines. The two types of air start units discussed are trailer-mounted and tractor-mounted units.

A/M47A-4 Trailer-Mounted Jet Aircraft Start Unit

The A/M47A-4 jet aircraft start unit (fig. 1-19) is a trailer-mounted gas turbine air compressor used to provide air and electrical power for starting jet engines. The start unit requires manual start, stop, and air selection. It provides air at 5:1 or 3.6:1 air pressure ratios and by way of a 30 kVA, 400-Hz generator, provides 115/208 volts of ac and 28 volts of dc for operating aircraft electrical systems.

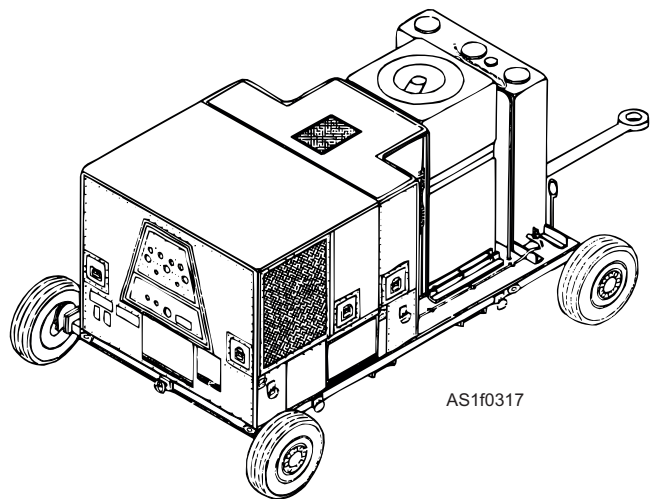

AS1f0317

Figure 1-19.—A/M47A-4 trailer-mounted jet aircraft start unit.

A/S47A-1 Tractor-Mounted Jet Aircraft Start Unit Enclosure

The A/S47A-1 tractor-mounted unit enclosure (fig. 1-20) is a self-contained mobile turbine engine air start unit. The air start unit enclosure consists of a control panel, gas turbine engine, stowage rack, and turbine support and mounting assembly. The enclosure contains all systems necessary for gas turbine engine operation except for fuel and electrical power.

Q1-40. The A/M47A-4 jet aircraft start unit is trailer mounted.

1. True
2. False

MOBILE AIR-CONDITIONERS

Today's modern aircraft have an abundance of electronic equipment that generates a tremendous amount of heat, which makes air conditioning a requirement in the air or on the ground. This is done by an onboard system, but the aircraft engines must be operating for this system to work. This is not practical on the ground when maintenance, testing, or calibration require the electronic equipment to run for long periods of time. Therefore, another form of air conditioning is needed, and that is why we have mobile air-conditioners. Mobile air-conditioners provide filtered air for cooling, dehumidification, or ventilation. There are several different types and models, but this text covers only the two models that are commonly used by the Navy—the A/M32C-17 and the A/M32C-21.

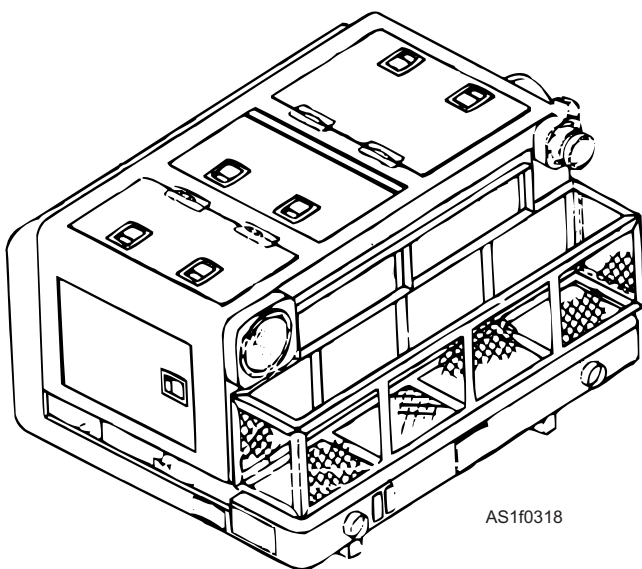

Figure 1-20.—A/S47A-1 tractor-mounted enclosure.

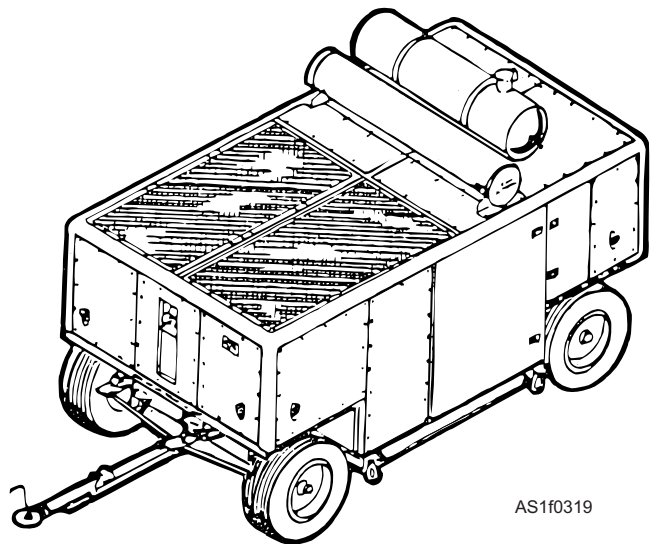

Figure 1-21.—A/M32C-17 mobile air-conditioner.

A/M32C-17 Mobile Air-Conditioner

The A/M32C-17 mobile air-conditioner (fig. 1-21) is trailer mounted and powered by a 6-cylinder, V-71 Detroit diesel engine. The operating components are contained within a metal paneled housing and are assembled into a refrigeration system, a ventilation system, a hydraulic system, and associated sensing and control components. The trailer contains its own braking system (surge brake), and the refrigeration system is serviced with R-22.

A/M32C-21 Mobile Air-Conditioner

The A/M32C-21 mobile air-conditioner (fig. 1-22) is trailer mounted and powered by a 30-horsepower, 440-volt, 3-phase, 60-Hz ac electric motor. A 60-foot-long external input power cable is stored on the brackets at the rear of the unit. The two front wheels are mounted close together on a caster assembly. A tow bar

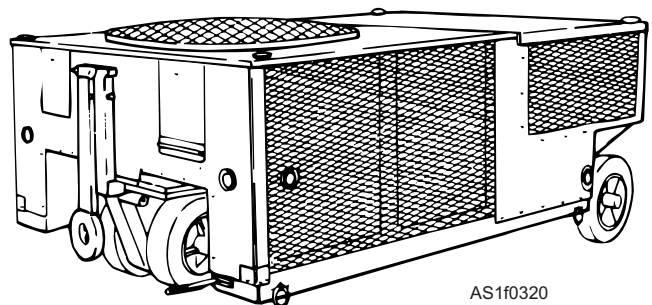
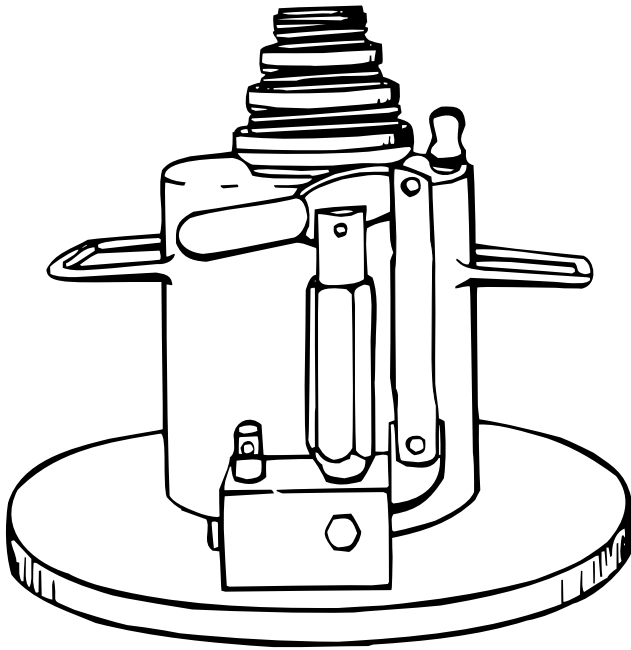

Figure 1-22.—A/M32C-21 mobile air-conditioner.



AS1f0321

Figure 1-23.—A3-1HC axle jack.

attached for steering folds up in half for storage, and is held rigid in the unfolded position by a latch and pin assembly. A 30-foot collapsible duct hose is used to transfer air from the unit to the aircraft. The refrigeration system is serviced in the same manner as a A/M32C-17.

Q1-41. What type refrigerant is used to service the A/M32C-17 and A/M32C-21 mobile air-conditioners?

1. R-12
2. R-134
3. R-22
4. R-24

AIRCRAFT MAINTENANCE EQUIPMENT

All aircraft require scheduled or unscheduled maintenance at one time or another. Some equipment used to support the maintenance efforts of the squadron include hydraulic jacks, aircraft maintenance stands, and engine transportation trailers.

Hydraulic Jacks

All aircraft hydraulic jacks are designated as either axle jacks or tripod jacks. They come in various shapes, sizes, and maximum load ratings, and are used for different applications. The correct jacks for a specific aircraft can be determined by consulting the *Index and Application Tables for Aircraft Jacks*, NAVAIR 19-70-46.

Aircraft jacks have various scheduled and unscheduled maintenance requirements, such as repair, adjustment, lubrication, and performing load tests. To comply with these requirements, you will need the applicable Maintenance Instruction Manual; *Aircraft Jacks, Various*, NAVAIR 19-70-521; and *Periodic Maintenance Requirements Manual*, NAVAIR 19-600-135-6-2.

AXLE JACKS.—Axle jacks are primarily used for raising one main landing gear or the nose gear of aircraft for maintenance of tires, wheels, brakes, and struts. There are two types of axle jacks, and all different sizes (lifting capacities). The two types are the hand-carried axle jack (fig. 1-23) and the outrigger axle jack, commonly known as the rhino jack (fig. 1-24). Designation for an A3-1HC is as follows:

- A = axle jack
- 3 = load capacity in tons (followed by a dash)
- 1 = specific jack identification number
- HC = hand-carried

TRIPOD JACKS.—Tripod jacks are primarily used for lifting the entire aircraft off the ground or deck. There are two types of tripod jacks, variable height (fig. 1-25) and fixed height (fig. 1-26). Designation for a T20-1VH5 is as follows:

- T = tripod jack
- 20 = load capacity in tons (followed by a dash)
- 1 = specific jack identification number
- VH = variable height
- 5 = the number of leg extension kits available for this jack

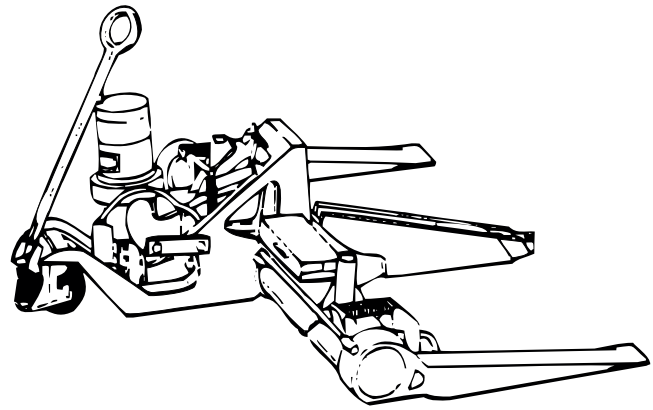

AS1f0322

Figure 1-24.—A45-2OR axle jack.

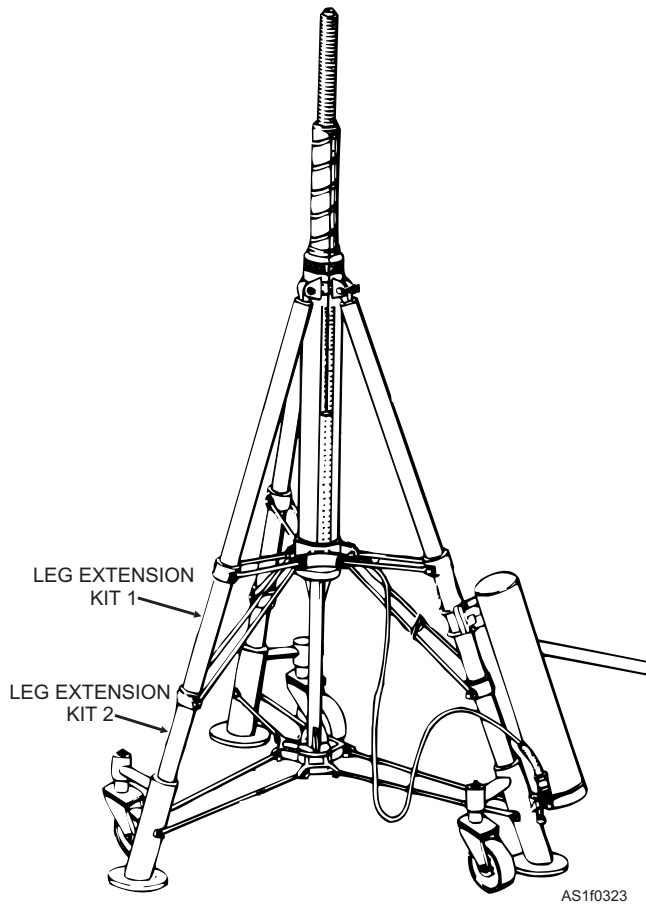

Figure 1-25.—Variable height tripod jack, two-leg extension.

Maintenance Platforms and Trailers

Maintenance stands, platforms, or work stands (the names are commonly interchangeable) provide a means to reach most parts of an aircraft that can not be reached safely from on the ground. There are a variety of types and models available. The following text discusses a few of the common maintenance stands.

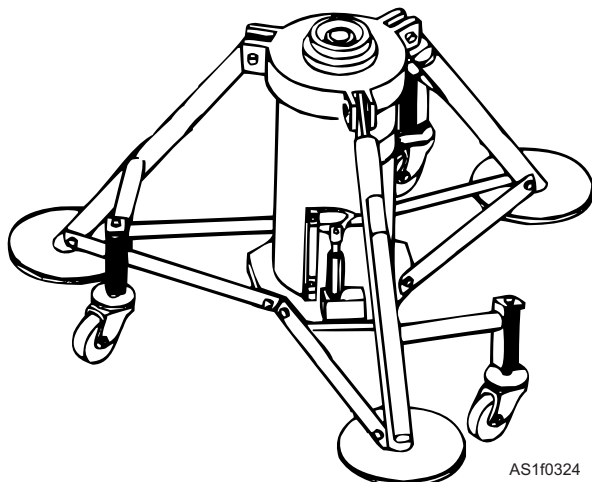

Figure 1-26.—Fixed height tripod jack.

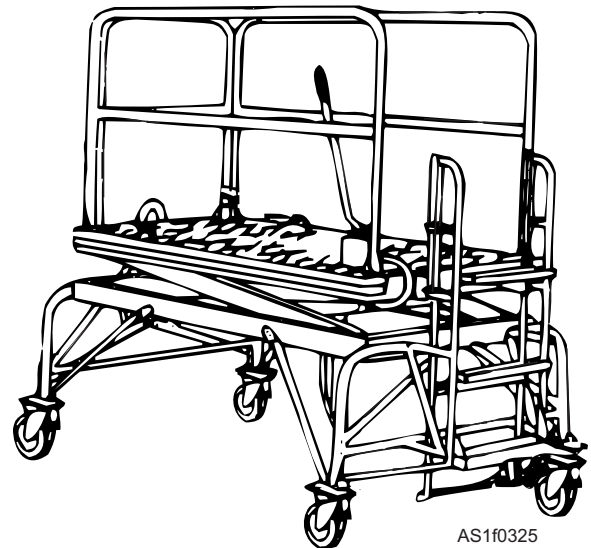

Figure 1-27.—B-4A maintenance platform.

B-4A MAINTENANCE PLATFORM.—The B-4A maintenance platform (fig. 1-27) is a moveable, hydraulically operated, adjustable platform with a ladder assembly. It has free swivel caster assemblies, with each having a foot lever-actuated mechanical brake and lock mechanism. The platform is equipped with safety guardrails and locking pins that lock the extension scissors. This prevents the platform from collapsing in the event of a hydraulic system failure. The height range is 3 to 7 feet. Overall height of the B-4A is 6-1/2 feet lowered and 10-1/2 feet raised, and it has a weight bearing capacity of 600 pounds.

B-5A MAINTENANCE PLATFORM.—The B-5A maintenance platform (fig. 1-28) is a moveable,

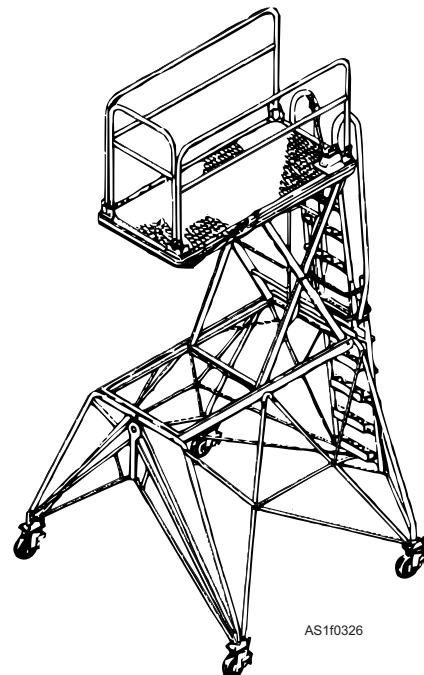
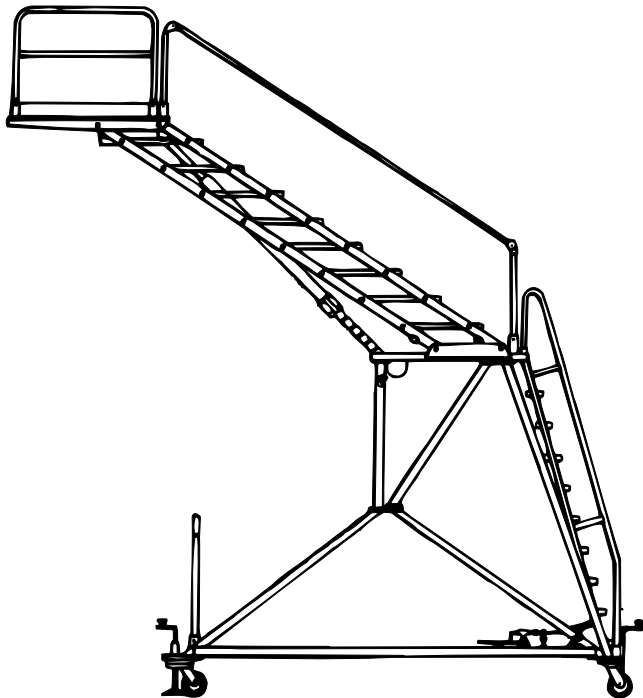

Figure 1-28.—B-5A maintenance platform.

hydraulically operated, adjustable platform with a ladder assembly. It has free swivel caster assemblies, with each having a foot lever-actuated mechanical brake and lock mechanism. The platform is equipped with safety guardrails and locking pins that lock the extension scissors. This prevents the platform from collapsing in the event of a hydraulic system failure. The height range is 7 to 12 feet. Overall height of the B-5A is 10 feet 7 inches lowered and 15 feet 6 inches raised, and it has a weight bearing capacity of 600 pounds.

B-2 MAINTENANCE PLATFORM.—The B-2 maintenance platform (fig. 1-29) consists of a fixed height, 10-foot lower structure, a variable height upper structure, and a manual pump actuated hydraulic system for raising and lowering the upper structure. The platform has guardrails and the steps have handrails. It has free swivel caster assemblies, with each having a foot lever-actuated mechanical brake and lock mechanism. The lower structure also includes four jack pads that act as brakes. The height range is from 13 to 20 feet. Overall height of the B-2 is 16-1/2 feet lowered and 23-1/2 feet raised, and it has a weight bearing capacity of 600 pounds. The work platform is 4 feet by 4 feet square.

A/S48M-2 (DIESEL) AND A/S48M-3 (ELECTRIC) SERVICING PLATFORMS.—The platforms, A/S48M-2 diesel powered (fig. 1-30) and A/S48M-3 electric powered (fig. 1-31) are used to



AS1f0327

Figure 1-29.—B-2 maintenance platform.

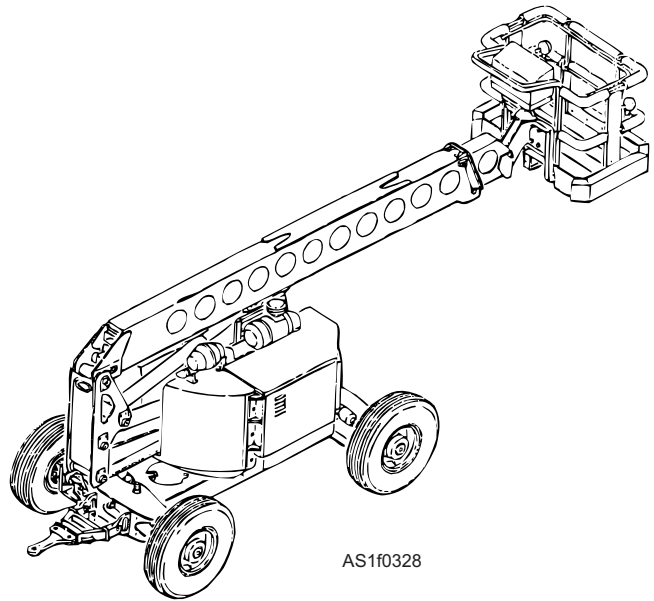

AS1f0328

Figure 1-30.—A/S48M-2 diesel servicing platform.

position personnel and equipment within functional proximity of a work site at a maximum elevation of 44 feet. The platform turntable is capable of 360-degree rotation in either direction. Platform functions are primarily controlled from the upper control box; however, some functions can be controlled from the lower control box. All platform functions are electrohydraulic. These platforms have four-wheel drive with steering accomplished by hydraulic steering cylinders on the front and rear axles.

NET-4 ENGINE TRANSPORT TRAILER.—The Net-4 engine transportation trailer (fig. 1-32) is a four-wheel trailer designed for transporting large jet engines and airframe sections. The towbar is extendable for transporting unusually long loads.

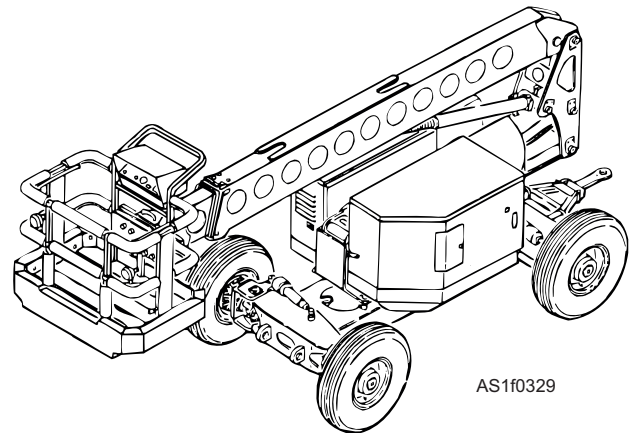

AS1f0329

Figure 1-31.—A/S48M-3 electric servicing platform.

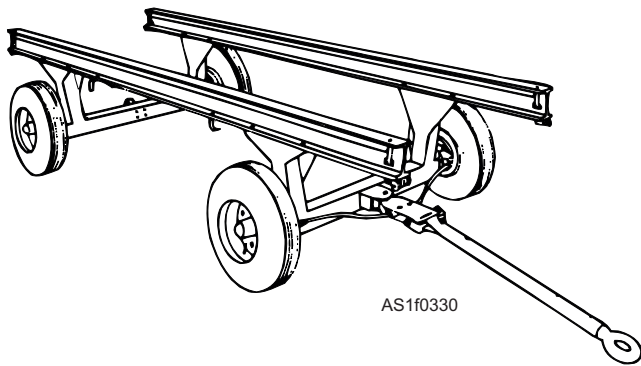

Figure 1-32.—Net-4 transportation trailer.

Pneumatic tires protect the load from shock, and a brake and pedal are mounted at each of the rear wheels.

4000A ENGINE REMOVAL TRAILER.—The 4000A engine removal trailer (fig. 1-33) is a mobile, hydraulically controlled, self-supporting unit. It is designed for removing and positioning aircraft engines and moving them short distances. The trailer consists of a main frame supported by four wheels, a lift linkage system, an upper frame that holds two cradle assemblies, and a tube and rail assembly. It has a detachable towbar, and it is also extendable for longer loads. Foot lever-actuated drum/shoe type parking brakes are located on the two rear wheels.

Q1-42. To determine the correct jack for a specific aircraft, you should refer to which of the following publications?

1. NA 19-70-46
2. NA 19-70-521
3. NA 01-1A-509
4. NA 16-1-540

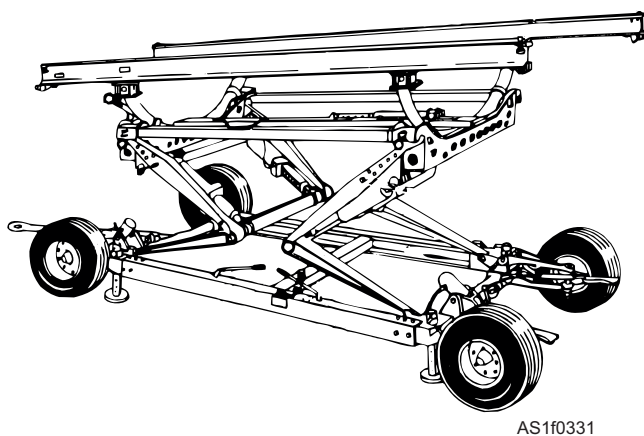

Figure 1-33.—4000A engine removal trailer.

Q1-43. What is the weight bearing capacity for a B-5A stand?

1. 200 lb
2. 300 lb
3. 500 lb
4. 600 lb

Q1-44. What unit of support equipment would you use to remove and position an aircraft engine?

1. 4000A engine removal trailer
2. Net-4 engine transport trailer
3. 3000A engine removal trailer
4. Net-5 engine transport trailer

NITROGEN AND OXYGEN SERVICING UNITS

Many aircraft systems require the use of nitrogen and oxygen servicing units. The following text discusses only three of the servicing units available to the fleet.

A/U26U-4 Nitrogen Servicing Unit

The A/U26U-4 nitrogen servicing unit (fig. 1-34) is more commonly known as the NAN-4. It provides a mobile source of compressed nitrogen to recharge aircraft nitrogen systems. It consists of a steel frame assembly mounted on two wheels, and a retractable front landing wheel. There are two groups of three

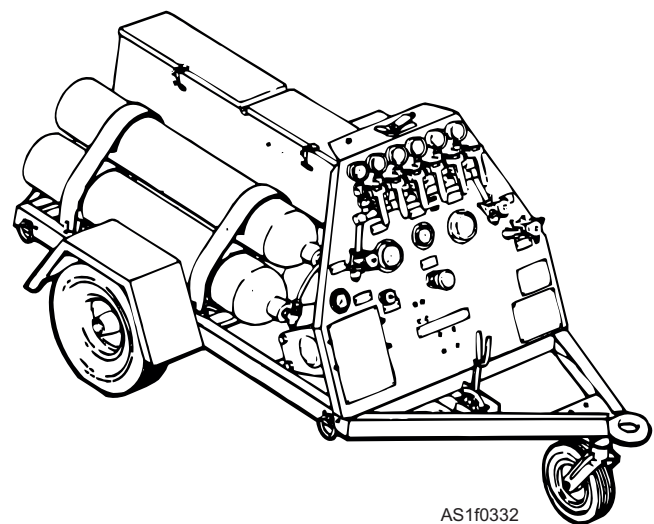

Figure 1-34.—A/U26U-4 nitrogen servicing unit.

nitrogen cylinders mounted on each side of the frame. It also has a hand-operated parking brake for use when operating or storage. The nitrogen is delivered through a series of gauges, filters, valves, and hoses located on the control panel. A pressure regulator controls the desired output pressure, and this unit is equipped with a boost pump that can boost the supply pressure to a maximum of 3,500 psi.

A/U26U-1A Oxygen Servicing Unit

The A/U26U-1A oxygen servicing unit, (fig. 1-35) provides oxygen to replenish storage cylinders and emergency bailout oxygen systems installed in aircraft. It consists of a steel frame assembly mounted on two wheels and a retractable front caster. There are three gas cylinders mounted on the frame, two nitrogen cylinders, and one oxygen cylinder. The nitrogen is used to drive the boost pump, and the oxygen is used to service oxygen systems. It also has a hand-operated parking brake for use when operating or storage.

TMU-70 Liquid Oxygen Servicing Unit

The TMU-70 liquid oxygen servicing unit (fig. 1-36) is primarily used to service aircraft LOX (liquid

oxygen) converters. This unit has storage tanks, transfer lines, and control valves, liquid level gauges, pressure gauges, and pressure-relief devices. These components are located on a steel frame assembly mounted on two wheels, and a retractable front wheel. It also has a hand-operated parking brake for use when operating or storage. This unit has a 50-gallon capacity and a closed-loop transfer system designed to reduce oxygen loss during transfer.

Q1-45. What is the A/U26U-4 servicing unit used for?

1. To replenish nitrogen storage cylinders
2. To recharge aircraft nitrogen systems
3. To replenish oxygen storage cylinders
4. To recharge aircraft oxygen systems

Q1-46. How many oxygen cylinders are on the A/U26U-1A?

1. One
2. Two
3. Three
4. Four

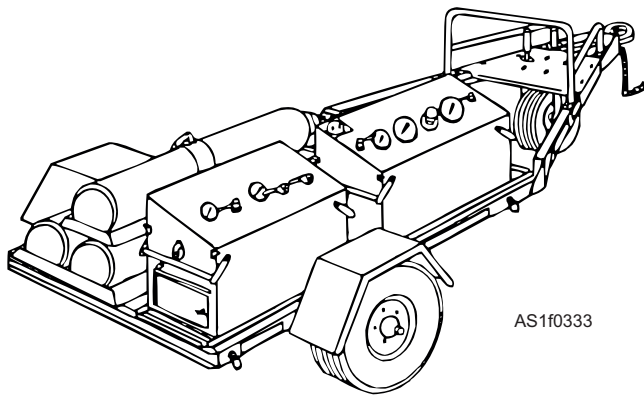

Figure 1-35.—A/U26U-1A oxygen servicing unit.

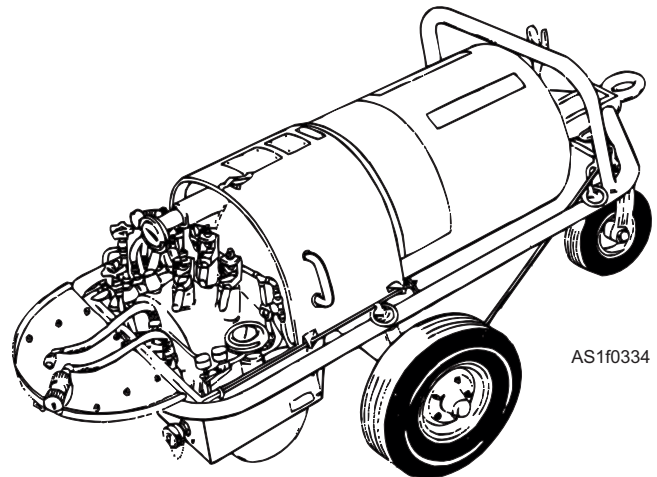

Figure 1-36.—TMU-70 liquid oxygen servicing unit.

CHAPTER 2

CHASSIS AND ATTACHING SYSTEMS

INTRODUCTION

The chassis of a vehicle provides the strength necessary to support the vehicular components and the payload placed upon it. The suspension system, part of the chassis, contains the springs, shock absorbers, tires, and wheels. The steering mechanism is also part of the chassis and suspension, and it provides the operator with a means of controlling the direction of travel. The transmission, propeller shaft, universal joints, differential, axles, wheels, tires, brakes, and steering system are part of the chassis. The body or outer portion of the vehicle encloses the mechanical parts and passenger compartment, but is not considered part of the chassis. The components that make up the chassis of the vehicle are held together in proper relation to each other by the frame.

NOTE: *Basic Machines*, NAVEDTRA 14037, has an entire chapter devoted to the power train. This chapter covers those components that are not adequately covered in *Basic Machines*, and some of the applications and different arrangements of power trains in support equipment.

Most chassis repair jobs require work by mechanics under hoisted or jacked up vehicles. When new personnel report to your shop, never assume that they have been instructed in the safety precautions that must be observed when working under a vehicle. Personnel should be instructed in the use of jacks, safety stands, and other safety devices used in your shop. After a person has been pinned under a falling vehicle, it is too late to give safety instructions.

FRAMES

LEARNING OBJECTIVES: Identify the purpose of the frame. Describe the working relationship between the frame and the chassis. Identify procedures for inspecting, checking, and adjusting the frame.

The frame is generally constructed of steel, and it is built rigid and strong so that it can withstand shocks,

twists, vibrations, and other strains (fig. 2-1). The side members or rails are the heaviest parts of the frame. The crossmembers are attached to the side members strongly enough to prevent twisting of the frame. For added strength, angular pieces of metal (gusset plates) are riveted or welded at the points where members are joined.

Frames normally require very little or no maintenance or service. Frames that have been bent, twisted, or broken, however, may be repaired if the damage is not too severe. Frame alignment can be checked in several ways. One way of checking the frame for forward alignment is by using frame gauges. Frame gauges (each gauge has a sight mounted on its center crossbar) are hung from the vehicle's frame in three places. Frame alignment is checked by sighting from the front of the vehicle toward the rear. If the sights on the center of the gauges do not line up, the frame is out of alignment.

If the frame is out of line, it is usually permissible to straighten it, provided the lack of alignment is not too great. You should consult the appropriate technical manual before you attempt to straighten the frame. When frame members have been broken or so badly distorted that they require replacement, new members can be installed with nuts and bolts or welded. The preferred method is to use hot rivets. When the front suspension crossmember has been damaged, you normally replace it. The front suspension crossmember is manufactured to such close tolerances that it is practically impossible to restore it to perfect alignment by straightening. If the front crossmember is not in line, the front wheels cannot be aligned, and the result is poor steering and rapid tire wear.

For frame and chassis repairs that require welding and in-depth skin and rivet replacement, refer to the applicable equipment technical manuals. Other pertinent manuals include the *Aeronautical and Support Equipment Welding Manual*, NAVAIR 01-1A-34; *General Manual for Structural Repair*, NAVAIR 01-1A-1; and *Structural Hardware*, NAVAIR 01-1A-8.

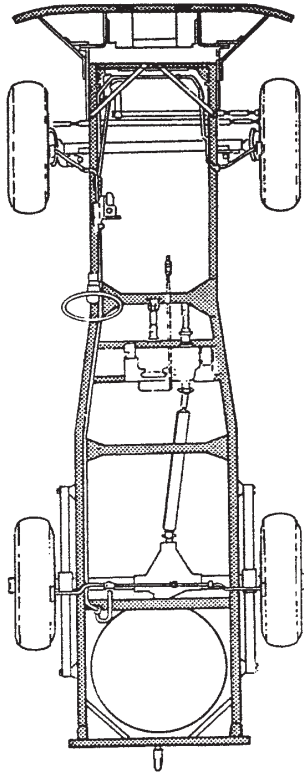

A. AUTOMOTIVE TYPE FRAME

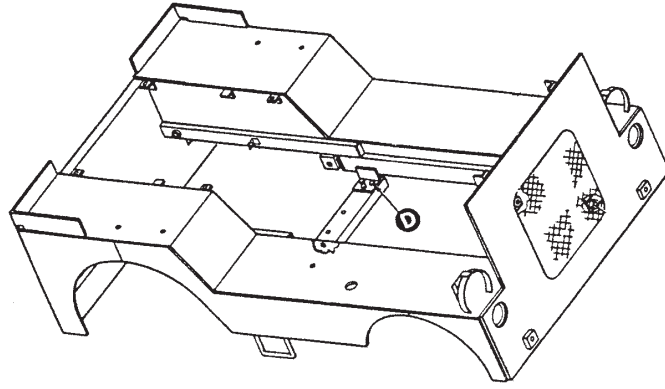

ASF02001

B. TOW TRACTOR FRAME

Figure 2-1.—Typical frames.

Q2-1. Before you attempt to repair a bent or broken frame, you should first consult which of the following resources?

1. The SE division chief
2. The airframes shop
3. The manufacturer of the equipment
4. The appropriate technical manuals

Q2-2. What is the preferred method of installing a new member in a frame that has been badly distorted?

1. Join them together with nuts and bolts
2. Use hot rivets to join the two pieces
3. Spot weld the joint
4. Cold weld all joints on both sides

AXLES

LEARNING OBJECTIVES: Identify the categories of axles. Describe the relationship between the axle and the chassis.

Although axles used on support equipment are of different sizes, shapes, and lengths, they are classified

into two distinct categories—driving and nondriving (fig. 2-2). The driving axles, also known as live axles, transmit power from the transmission to the driving wheels of the vehicle. The driving wheels can be the front or rear of the vehicle. Nondriving axles, also

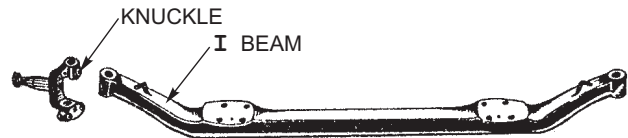

(NONDRIVING)

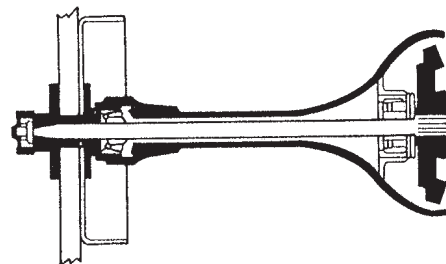

(DRIVING)

ASF02002

Figure 2-2.—Axles (driving and nondriving).

known as dead axles, are mounted to the frame of the chassis and remain stationary. This type of axle may run the entire width of the vehicle or may be only a short axle mounted to the side of the frame or chassis. Some nondriving axles will have wheels mounted directly on the end of the axle, such as the rear wheels of a trailer. Others, such as the front wheels of a trailer, will have the wheels mounted on nonsteering knuckles, which, in turn, are mounted on the ends of the axle.

Axles require very little maintenance. However, nondriving axles may require straightening or replacement after accidents or rough handling. Whenever a vehicle has a bent or damaged nondriving axle, the appropriate technical manual must be consulted for the repair limits and procedures. If trouble develops with a driving axle, the only solution is to replace it. Normally, the only trouble encountered with driving axles results from defective wheel bearings or a complete break of the axle.

Driving axles are encased in a housing; therefore, they are isolated from the outside elements. Replacement of a driving axle requires removal of several parts from the axle housing. For semi-floating or full-floating axles, only the axle is unbolted, and it can be removed without removing the wheel assembly. As the parts are removed, you must take care not to further damage seals, threads, splines, or

bearing surfaces. Never strike the end of an axle shaft to loosen it, as this may damage the bearings or differential.

Most all of your axle work will result from scheduled maintenance requiring the removal, cleaning, and repacking of wheel bearings, as shown in figure 2-3. It is very important to properly pack wheel bearings because the grease must be forced between the rollers. If the grease is only smeared on the outside of the bearing, the bearing may overheat and destroy itself. Also, ensure that the bearings are completely dry before they are packed with lubricant. Water or condensation will cause the bearings to rust.

WARNING

Never spin a bearing by blowing compressed air across it. This may damage the bearing by causing it to seize up or fly apart, injuring the person holding the bearing.

Q2-3. What are the two types of axles used on SE?

1. Moving and stationary
2. Internal and external
3. Driving and nondriving
4. Ridged and flexible

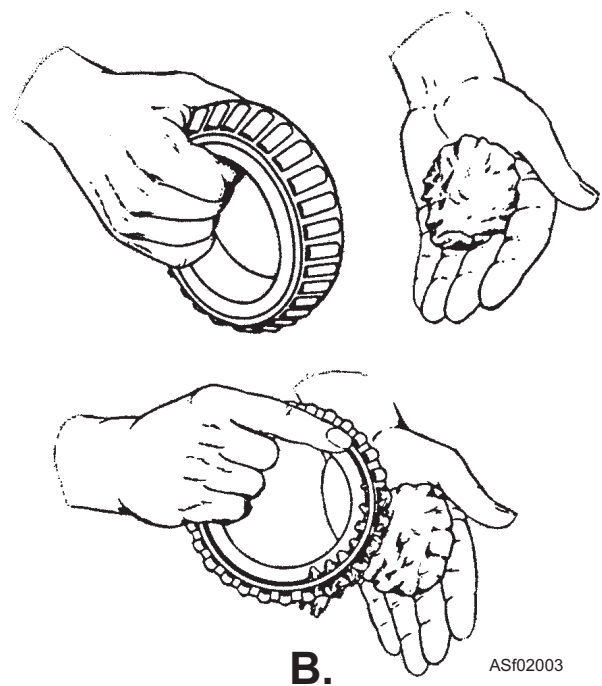
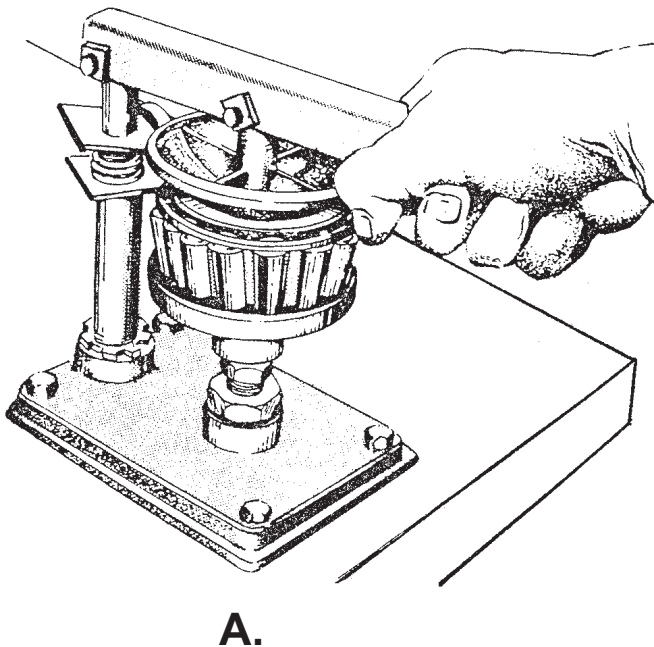

ASf02003

Figure 2-3.—Packing wheel bearings.

Q2-4. How are drive axles secured to an item of SE?

1. They are encased in a housing
2. They are bolted to the frame with U-bolts
3. They are welded to the frame
4. They are attached by the springs and shocks

Q2-5. Ensuring grease is forced between the rollers of a wheel bearing is a very important step to prevent the bearing from overheating.

1. True
2. False

SUSPENSION SYSTEMS

LEARNING OBJECTIVES: Identify the normal components of a suspension system. Identify the springs used on suspension systems. Describe the shock absorbers used on a suspension system.

The suspension systems for support equipment differ from most highway-driven vehicles. Most of the support equipment is not designed to travel over 15 to 20 miles per hour, and is only required to move short distances. The normal components of a suspension system are the springs and shock absorbers. However, some tow tractors have no rear springs, as the axles are bolted to the frame. Support equipment with suspension systems have either leaf or coil springs.

SPRINGS

Springs support the frame above the axle and the body of the vehicle, as well as the equipment mounted on the vehicle. They provide a flexible connection between the wheels and the frame and allow the vehicle to withstand the shocks of uneven surfaces. The best spring is one that absorbs shock rapidly and returns to its normal position slowly. Since the spring cannot perform this function alone, it is assisted by a shock absorber. Very flexible springs allow too much movement of the frame, while stiff springs do not allow enough movement. The springs do not actually support the weight of the wheels and axles. These parts make up the unsprung weight of the vehicle, which decreases the action of the springs. Therefore, the unsprung weight is kept to a minimum to permit the springs to support the vehicle frame and load.

Coil springs (fig. 2-4) are used on most independent suspension systems because of low cost

and maintenance. The main disadvantage of coil springs is that their frictionless action results in too much pitching of the vehicle. This pitching is dampened by the action of the shock absorber.

Figure 2-5, view A, shows how a coil spring is mounted. The spring seat and hanger are shaped to fit the coil ends and hold the spring in place. Spacers made of rubberized fabric are placed at each end of the coil to prevent squeaking. The rubber bumper, mounted in the spring supporting member, prevents metal-to-metal contact when the spring is compressed. Coil spring systems require torque rods or a stabilizer shaft to prevent the axle from moving forward and back.

Springs require very little maintenance; normally they are changed only when they fail. Leaf springs (fig. 2-5, view B) present no problem to change. The unit is raised until the tires are off the ground; then jack stands are placed under the frame. Next, a floor jack is placed under the axle, and it is raised until a no-load condition is obtained. Then, the bolts or pins holding the spring in place are removed, the spring is unbolted from the axle and removed, and the new springs are installed.

Coil springs (fig. 2-5, view A) are replaced in about the same manner, but must also be compressed by a spring compressor prior to removal and installation.

WARNING

Consult the applicable technical manual before trying to repair a faulty coil spring—they can be very dangerous if removed incorrectly.

SHOCK ABSORBERS

Springs alone are not always satisfactory in a vehicle suspension system. A stiff spring gives a hard ride because it does not flex and rebound when the vehicle passes over a bump. On the other hand, a spring that is too flexible rebounds too much, and causes the vehicle to ride rough. Shock absorbers are used to smooth the riding qualities of the vehicle. They prevent excessive jolting of the vehicle by balancing spring stiffness and flexibility. They allow the springs to return to rest slowly after having been compressed. Double-acting shock absorbers (fig. 2-6) check spring compression as well as rebound. Most shock absorbers used at present are of the double-acting type because they permit the use of the more flexible springs.

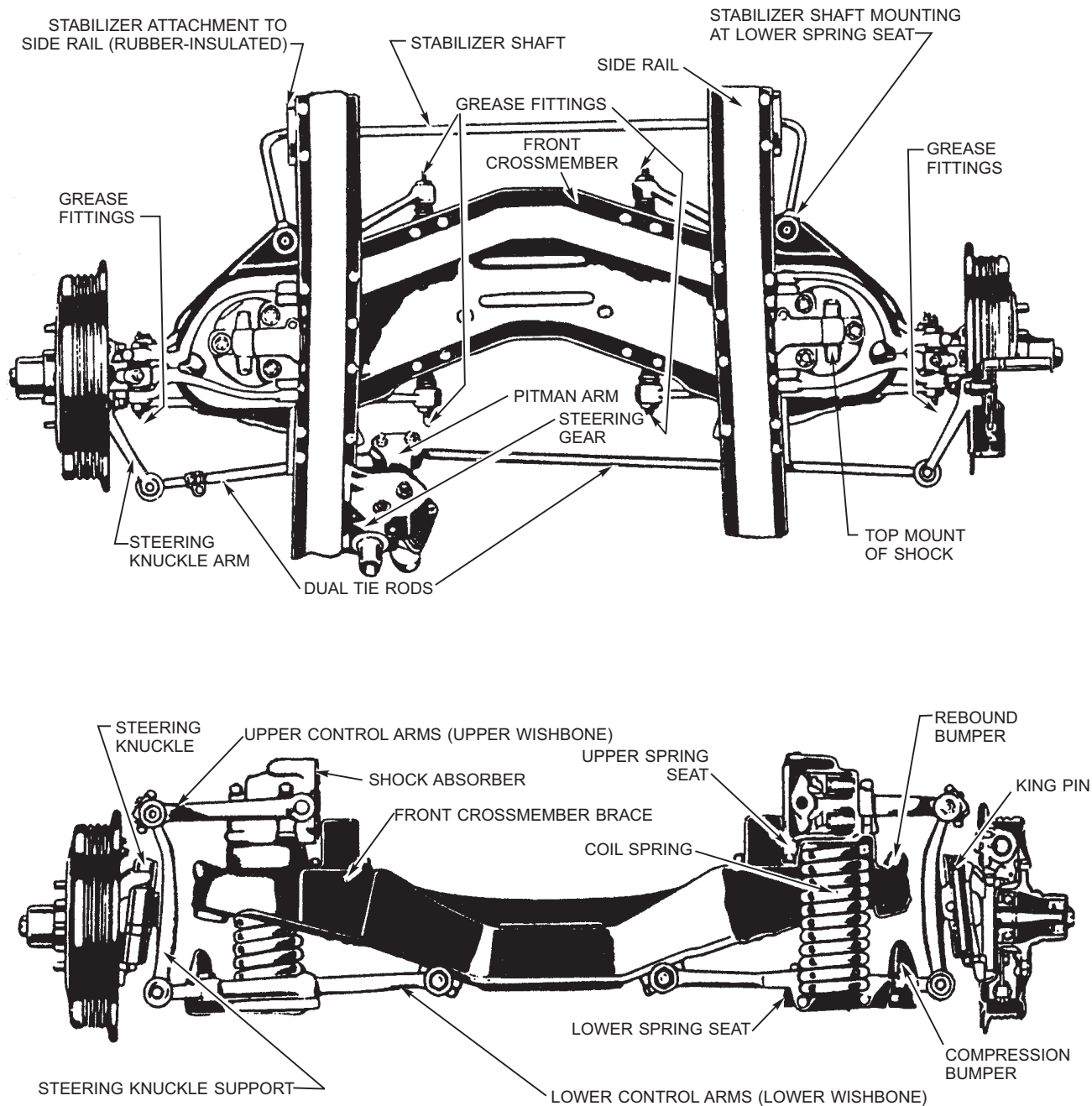

ASf02004

Figure 2-4.—Coil spring suspension.

Most shock absorbers used today are hydraulically operated, and their operation is easy to understand. When the springs are flexed, liquid hydraulic fluid within the shock absorber is forced through a small opening by a piston. Since liquids cannot be compressed, the movement of the piston is controlled by the rate of flow of the hydraulic fluid through the opening. The tube shock absorber, as shown in figure 2-6, is used on automotive equipment and most types of support equipment requiring shocks. The tube shock absorber is a self-contained unit that cannot be

repaired; it can only be replaced when it becomes inoperative.

Shock absorbers are usually attached to the vehicle, as shown in figure 2-5, view A. Rubber mountings are used to fasten shock absorbers to the frame and axle to eliminate wear and noise. Most shocks can be replaced by removing the hardware that holds them in place. The hardware may be bolts at both ends of the shock absorber or, in some styles, the shafts are threaded and washers and nuts hold them in place.

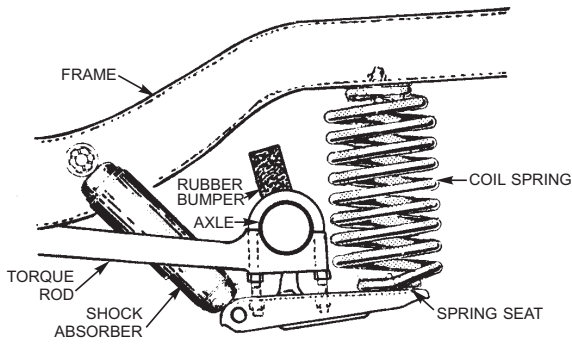

A. COIL SPRING

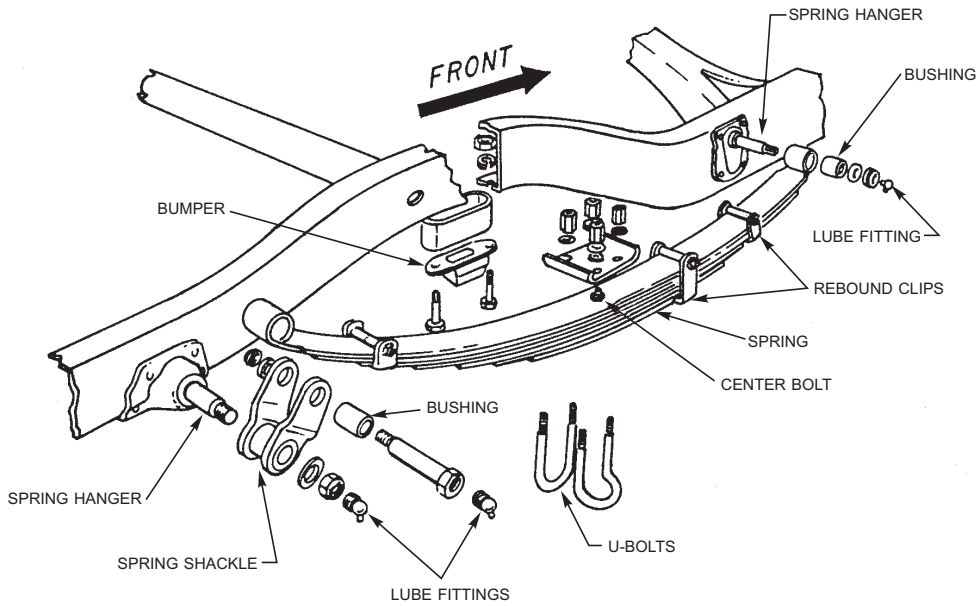

AS102002

B. LEAF SPRING

Figure 2-5.—Coil and leaf springs.

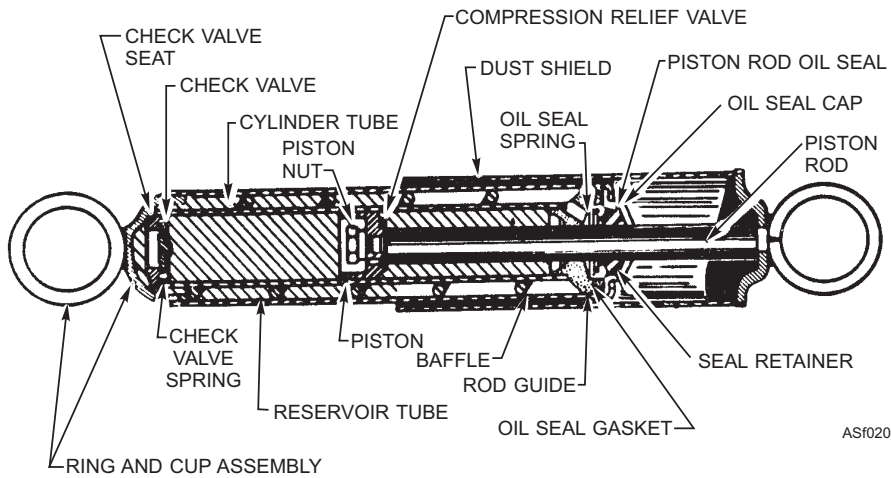

AS102006

Figure 2-6.—Double-acting shock absorbers.

Q2-6. Because they cannot absorb shock rapidly and they return to their normal position slowly, what component is used to assist the springs of a suspension system?

1. Rubber mounts
2. Keeper mounts
3. Shock absorbers
4. Torsion bars

Q2-7. The two types of springs used on SE are coil and leaf springs?

1. True
2. False

Q2-8. Most shock absorbers are operated by which of the following methods?

1. They are pneumatically operated
2. They are hydraulically operated
3. They are electrically operated
4. They are battery operated

STEERING

LEARNING OBJECTIVES: Identify the parts and purpose of a steering assembly. Identify procedures for troubleshooting a steering assembly. Identify procedures for repairing or replacing a steering assembly. Identify procedures for maintenance of a steering assembly.

Though steering may be a simple operation, the steering mechanism is rather complex. Figures 2-7 and 2-8 show diagrams of a steering mechanism.

STEERING ASSEMBLIES

All steering mechanisms have the same basic parts. The steering linkage ties the front wheels together and connects them to the steering gear case at the lower end of the steering column, which, in turn, connects the gear case to the steering wheel.

The arms and rods of the steering linkage have ball, or ball and socket, ends to provide a swivel connection between them. These jointed ends are provided with grease fittings, dust seals, or boots. Many of them have end-play adjustment devices. These joints and devices must be adjusted and lubricated regularly.

The arms, rods, and joints of steering linkages in your equipment may be arranged differently from those shown in figure 2-7. But, you will most likely

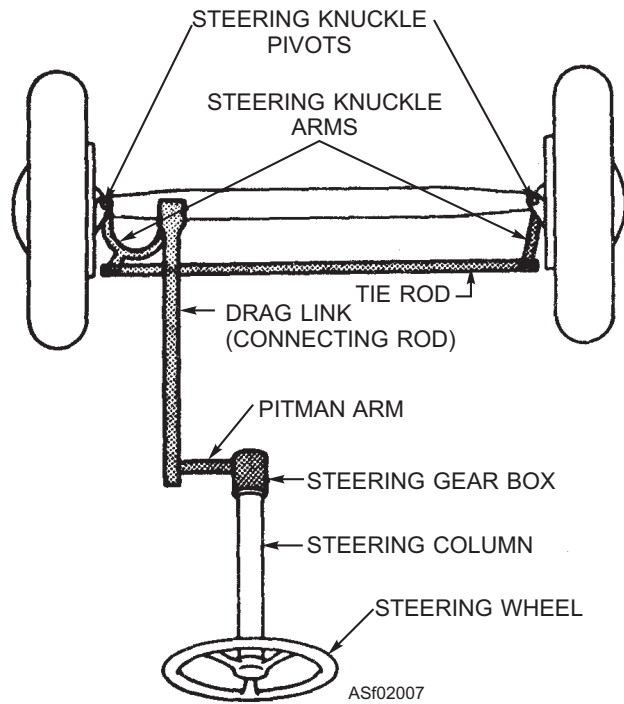

Figure 2-7.—Diagram of a steering mechanism.

find them in the same general location in the front or rear and underneath the vehicle.

The tie rod (fig. 2-7), for example, is usually located behind the axle and keeps the front wheels in proper alignment. To provide for easier steering and maximum leverage, the tie rod may be separated into two lengths and connected to the steering gear near the center of the vehicle. The rod (drag link) connecting the steering arm and the pitman arm may be long or short, depending on the installation.

The pitman arm (fig. 2-8) is splined to the shaft extending from the steering gear case and moves forward and backward—depending on which way the wheels are turned. It is approximately vertical when the front wheels are straight ahead. Therefore, the length of the connecting rod is determined by the distance between the steering arm and the vertical position of the pitman arm. Unlike the tie rods, the length of the connecting rod is not adjustable.

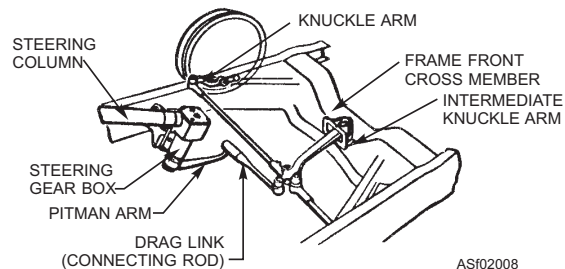

Figure 2-8.—Steering assembly.

The steering gear case contains the gears that control the movement of the pitman arm and steering linkage. Figure 2-9 shows a typical steering gear assembly, the location of the adjustment screw, and the filler plug for gear lubricant.

The principal parts of any steering gear unit are the worm gear and sector. A sector is a portion of a full gear. The sector gear and worm provide a ratio between the number of turns of the steering wheel to one turn of the pitman arm. Because the pitman arm does not turn a complete revolution, only a section of one gear is used in the gear arrangement. The gear ratio of the steering column and the cross shaft that carries the pitman arm varies from 4 to 1 to 18 to 1 in automotive equipment. The high steering gear ratios are used in vehicles that are hard to steer or are slow moving. The low steering gear ratios are used in vehicles that are easy to turn.

To provide easier and more efficient steering, roller and ball bearings have been added to the steering gear units. The design of the worm gear and sector has been changed, and even the names of these parts are different. In figure 2-9, the worm gear is called a cam and the sector is called a stud. These parts work on the same principle as a worm gear and sector.

Another form of steering gear is the recirculating ball and nut gear (fig. 2-10). In this assembly the nut is mounted on a continuous row of balls on the worm to reduce friction.

The ball nut is fitted with tubular ball guides to return the balls diagonally across the nut to recirculate them. As the nut moves up and down, the pitman arm turns, and the vehicle's wheels turn with it.

On equipment that is steered by the rear wheels, such as forklifts, the steering components and operation are the same except that a longer drag link is necessary to permit the driver to face forward. Because the steering column must be pointed forward to permit the operator to face forward, the distance from the gearbox and pitman arm to the steering knuckle arm is greater than on a front steering vehicle. Thus, a longer drag link is required.

POWER STEERING

Automotive power steering hydraulic systems consist of three units: the pump (including reservoir), the power cylinder or cylinders, and the control valve. The power steering pump is driven by the engine or an engine-driven accessory, by a belt, a shaft, or gears. Lines and hoses connect the three units, and all systems are constructed so that the vehicle can be steered manually, should the power steering system fail.

One type of power steering system has the power cylinder and control valve built into the gearbox or case at the base of the steering column. As the steering wheel is turned to the right or left, the control valve directs hydraulic fluid pressure to one side or the other of a piston in the power cylinder that is connected to the

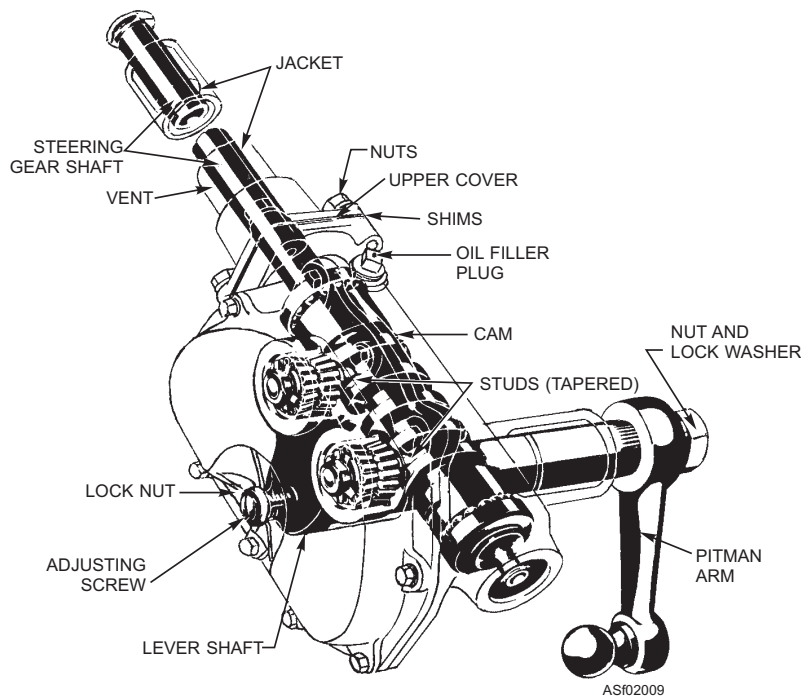
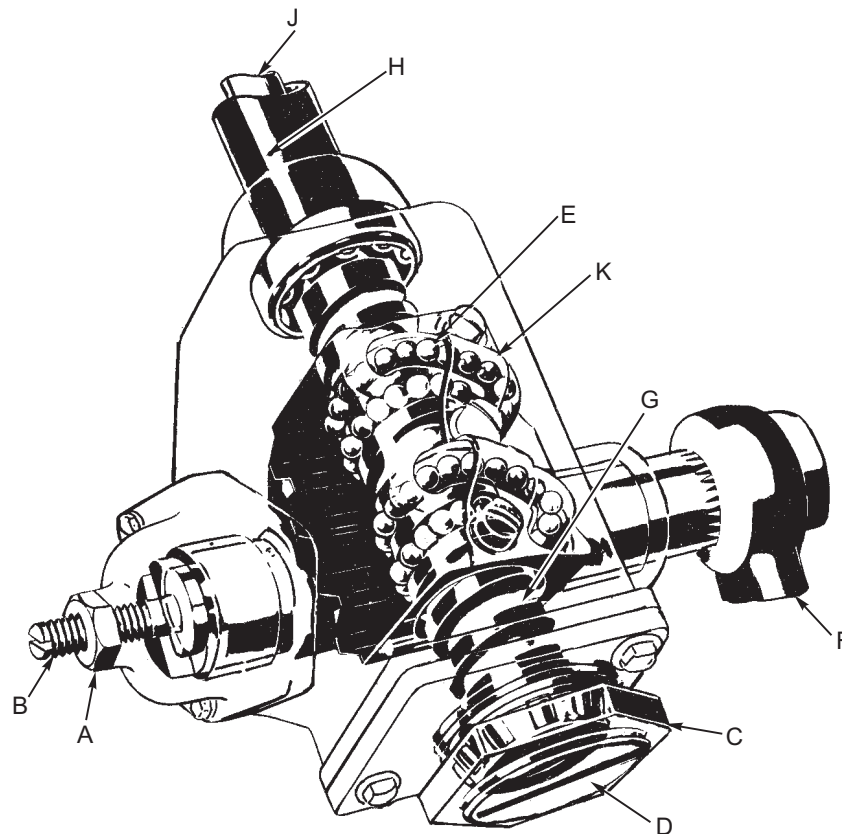

Figure 2-9.—Steering gear unit of the cam and lever type.



ASf02010

- | | |
|---|------------------------|
| A. Lash adjuster screw locknut | F. Pitman arm |
| B. Lash adjuster screw | G. Worm |
| C. Worm bearing adjusting screw locknut | H. Jacket |
| D. Worm bearing adjusting screw | J. Steering gear shaft |
| E. Recirculating balls | K. Ball nut |

Figure 2-10.—Recirculating ball-type steering gear.

pitman shaft and arm. When the driver returns the steering wheel to the neutral or straight ahead position, the pressure on both the right and left turn sides of the piston is equalized, and the vehicle travels straight ahead. The pump is usually adjacent to a fluid reservoir where the excess hydraulic fluid is stored. Figure 2-11 is a diagram of this type of system.

In the other type of power steering system, the control valve is on the pitman arm at the base of the steering column. The power cylinder is mounted on the tie rod between the wheels. In the system shown in figure 2-12, the power cylinder is double acting. When the steering wheel is turned, the pitman arm turns and routes fluid under pressure to one side of the cylinder, which assists in turning the wheels. When the steering wheel is neutral, equal pressure is applied to both sides of the power cylinder.

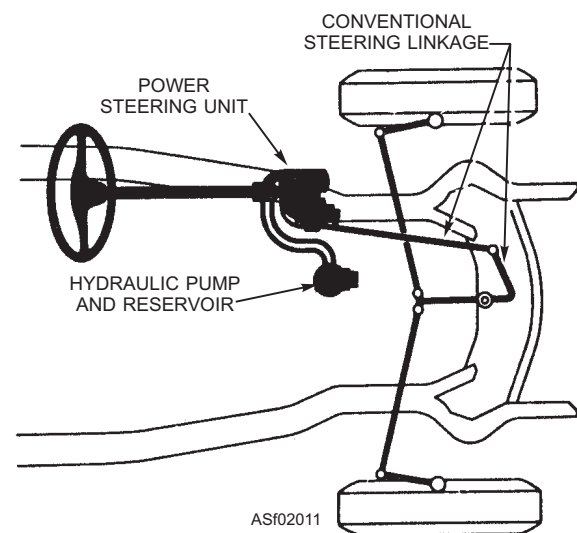

ASf02011

Figure 2-11.—Diagram of a power steering unit.

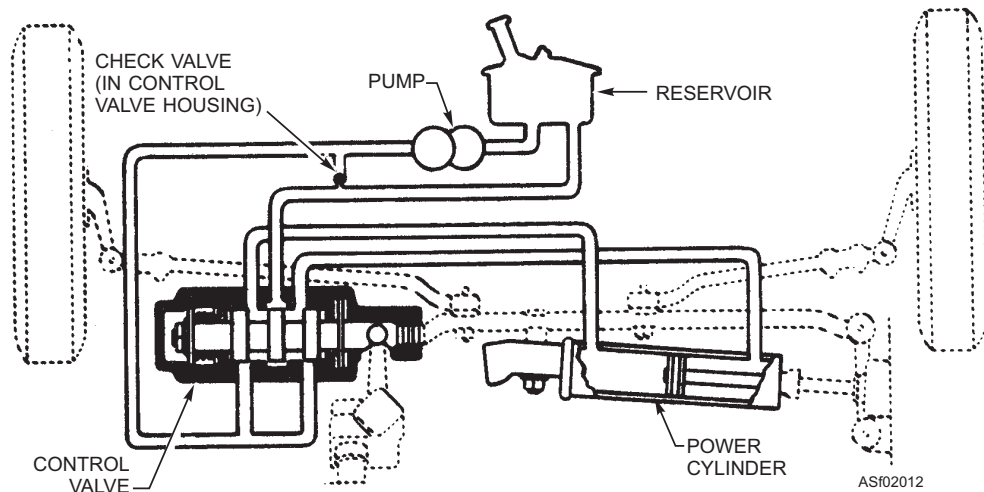

Figure 2-12.—Power steering system.

STEERING SYSTEM MAINTENANCE

Maintenance of the steering system consists of regular inspections, maintaining proper wheel alignment, lubrication, and occasional adjustment and replacement of parts to compensate for wear. The driver can usually sense steering and alignment troubles, as well as detect hard steering or play in the steering system. But, it is the responsibility of the AS to find the trouble and to remedy it.

Some play in the steering wheel is normal and provides for easier steering of the vehicle. A large amount of play, however, means a freer movement of the steering wheel without a corresponding movement of the front wheels. Too much wheel play is caused by improper adjustment or wear of the steering linkage, steering knuckle plates, or loose wheel bearings.

Hard steering may be caused by very tight adjustments, mechanical difficulties in the steering gear or linkages, not enough air in the tires, or improper wheel alignment.

Sometimes the driver may say that the vehicle “wanders.” However, it may be that the driver tends to over-steer the vehicle. Nevertheless, the vehicle should be checked for low tire pressures, tight or loose wheel and brake adjustments, or improper front wheel alignment. “Pulling” of the vehicle when braking could be caused by grabbing brakes. If the vehicle “pulls” when driven, check for proper toe-in and toe-out in addition to the other causes already mentioned.

Steering shocks, caused by sharp and rapid movements of the steering wheel, may be the result of driving over a rough surface or hitting objects on the

surface. When the vehicle does not steer properly, it should be checked for sagging springs, defective shock absorbers, or looseness in the steering gear or linkage. Uneven tire inflation also could be the cause.

Inspections

Steering components, springs, and shock absorbers should be checked daily before operation of the vehicle. This preoperational inspection consists of a visual inspection for signs of lubricant leakage, corrosion of steering or suspension components, and loose parts, such as steering or spring components. The preoperational inspection is normally the responsibility of the operator.

When inspecting the steering mechanism, you may need someone to assist you by turning the steering wheel back and forth through the free play while you check the linkage and connections. This will allow you to more easily determine if the steering gear is secured rigidly to the frame and no excessive looseness of the linkage or gearbox is present. A slight amount of free play may seem insignificant, but if allowed to remain, the free play will quickly increase and result in poor steering control.

Wheel Alignment

Steering control depends greatly upon the position of the wheels in relation to the rest of the vehicle and the surface over which it travels. Any changes from the specified setting of the wheels affect steering and the riding control of the vehicle. Therefore, the proper wheel alignment is important for vehicle control.

Front-end geometry is the term manufacturers use to describe steering and front wheel alignment. Front end geometry includes PIVOT INCLINATION, WHEEL CASTER, WHEEL CAMBER, TOE-IN, and TOE-OUT. These terms refer to angles in the front wheel alignment that may change because of driving over rough terrain, striking stationary objects, accident damage, and wear.

PIVOT INCLINATION (sometimes called kingpin angle) is the number of degrees that the kingpin is tilted toward the center of the vehicle from a vertical position (fig. 2-13). Pivot inclination keeps the wheel spindles pointed outward and in line with the axle, and helps to make steering easier.

WHEEL CASTER is the number of degrees that the steering knuckle is tilted to the rear, or to the front. Caster tends to keep the front wheels pointed straight ahead and brings them back to a straightforward position after a turn. The front wheel of a bicycle is castered and permits the rider to steer without using his hands. When the castered wheel of a bicycle is turned from the straight-ahead position by leaning sideways, the front end is slightly raised. After the turn is made, the weight of the bicycle forces the front end down and helps straighten the wheels.

Caster in automotive vehicles with leaf-type springs is obtained by inserting wedges or shims between the front axle and the spring so that the steering knuckle pivots are tilted slightly backward from the vertical. However, most modern automotive vehicles do not have leaf-type springs. Vehicles without leaf-type springs use shims between the upper

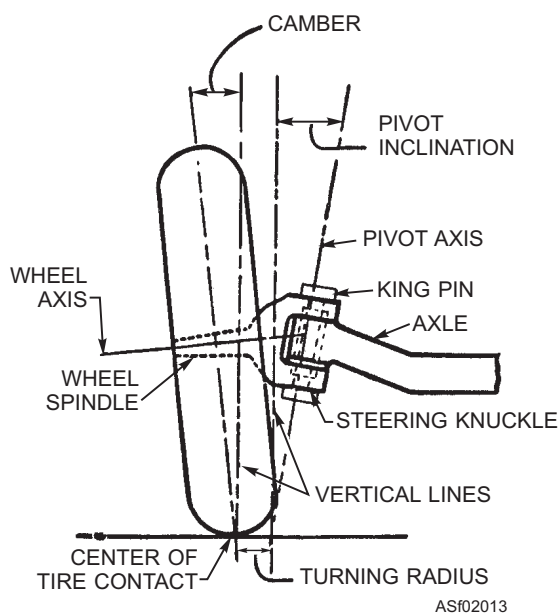

Figure 2-13.—Pivot inclination and camber.

suspension arm and the frame to obtain the desired caster. If the knuckle pivots (kingpins) are tilted forward, the caster is said to be negative (fig. 2-14). The caster is said to be positive when the knuckle pivots are tilted backward. Most vehicles have positive caster, but some modern vehicles have negative caster. Caster is measured in degrees and varies from approximately 0.5° to approximately 3° on modern vehicles. The technical manual for the vehicle should list the correct settings.

WHEEL CAMBER is the number of degrees that the wheels are tilted in or out at the top (fig. 2-13). Wheels having camber are closer together at the bottom than they are at the top. Camber, together with pivot inclination, reduces side thrust on the kingpin bearings in the steering knuckle and support, thus permitting easier steering and less wear of parts. Camber angle, in today's vehicles, very seldom exceeds 1° , and is obtained by tilting the wheel spindles slightly downward on the steering knuckles. Camber brings the wheels perpendicular to the surface of the road, permitting better rolling contact. Wheels that have camber must also have toe-in and toe-out.

NOTE: In modern vehicle design, greater pivot inclination reduces the need for excessive camber.

TOE-IN is the number of inches that the front wheels point in toward the center of the vehicle (fig. 2-15). When forced to follow a straight path by motion of the vehicle, cambered wheels tend to slip away from each other. But toe-in wheels tend to travel toward each other and, therefore, balance the effect of camber.

If your shop has floating turntables, use them to check steering errors. Run the vehicle up on the tables, and then turn the front wheels with the steering wheel. Each floating table turns with the wheel on it and registers the angle of the turn. When one wheel turns 20° , the other should turn about 23° , or to the specifications for your unit.

Before checking front wheel alignment, be sure that the front tires are properly inflated and that

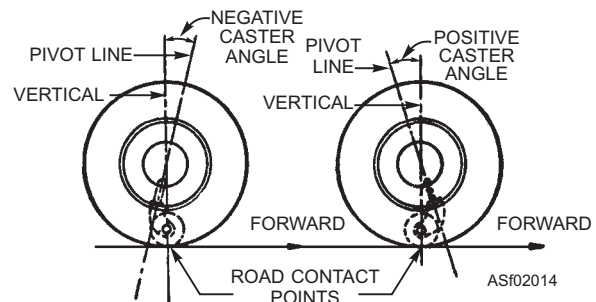

Figure 2-14.—A. Negative caster; B. positive caster.

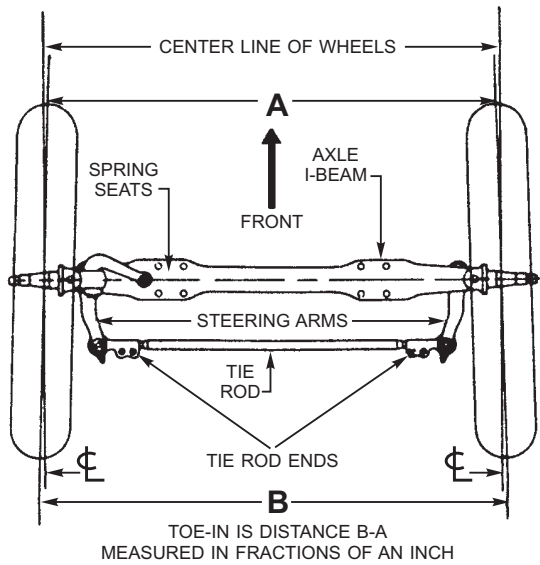

Figure 2-15.—Toe-in.

steering knuckles and linkages, shock absorbers, and wheel bearings are correctly adjusted. If any of the above items cannot be adjusted back to proper specifications, then that part or assembly must be replaced.

There are a number of devices that may be used for testing wheel alignment. One of the devices used for measuring toe-in is the measuring pole (fig. 2-16). Each pole has a pointer and a gauge on one end and can be lengthened and shortened like a curtain rod.

With the vehicle resting on a level floor and the wheels in a straight-ahead position, push the vehicle forward a few feet to remove all play in the axle assembly. Put pencil marks on the inside walls of the tires at equal distances from the floor, and at both the front and rear of the tire.

Place the pole between the two marks at the front of the tire, and set the pointer at zero. Then, use the pole to measure the distance between the two rear marks. The distance between the two rear marks should conform to the manufacturer's specifications. If not, it is necessary to adjust the toe-in.

TOE-OUT is the difference in the turning of the inner wheel, with the outer wheel turned at a 20-degree angle. Toe-out is necessary because of the different turning radii of the front wheels and the necessity for preventing slipping of the front wheels when turning.

Power Steering Maintenance

Since pressure builds up in the power steering system, the fittings, gaskets, and lines used in the system should be inspected frequently for leaks. When a fitting is found leaking, tighten or replace it. Gaskets and packing should be replaced when it is determined that they are leaking or faulty. The level of the fluid in the power steering system should be checked regularly and refilled as necessary. You should exercise care when adding fluid, ensuring no foreign matter enters

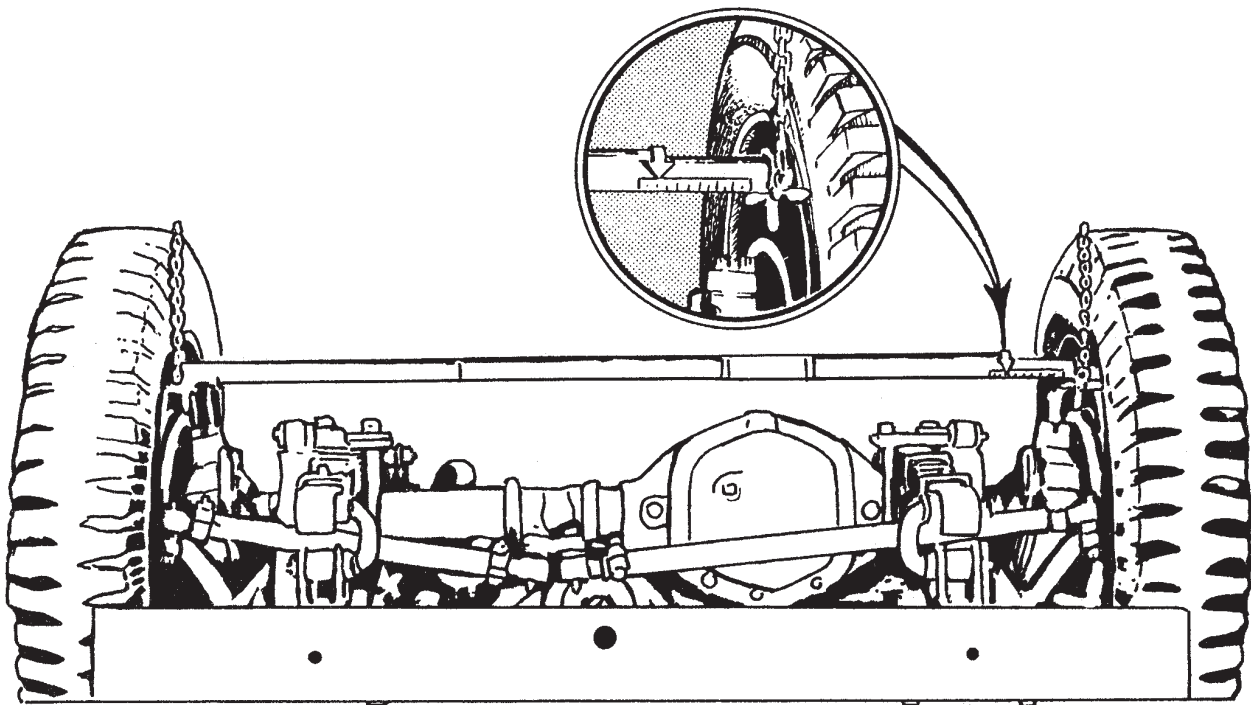

Figure 2-16.—Measuring pole.

the system to block the control valve and cause the system to malfunction.

In addition to linkage maintenance, there are other items in power or hydraulically assisted steering systems that must be inspected for condition and operability (fig. 2-17).

If the pump is belt driven, the first thing to check is the condition of the drive belt. Make sure that it is sufficiently tight to prevent slippage, yet loose enough to prevent damage to the shaft bearings. If in doubt as

to the proper adjustment, check the manufacturer's specification in the operator's or maintenance manual. The fluid level in the reservoir should be checked at each maintenance cycle and kept above the add or low mark. Inspect the hoses and connections for signs of leakage. Loss of even a small amount of fluid can damage the pump, so if leaks are found, make repairs as soon as possible.

The power steering system will absorb much of the looseness or slack that would be readily apparent

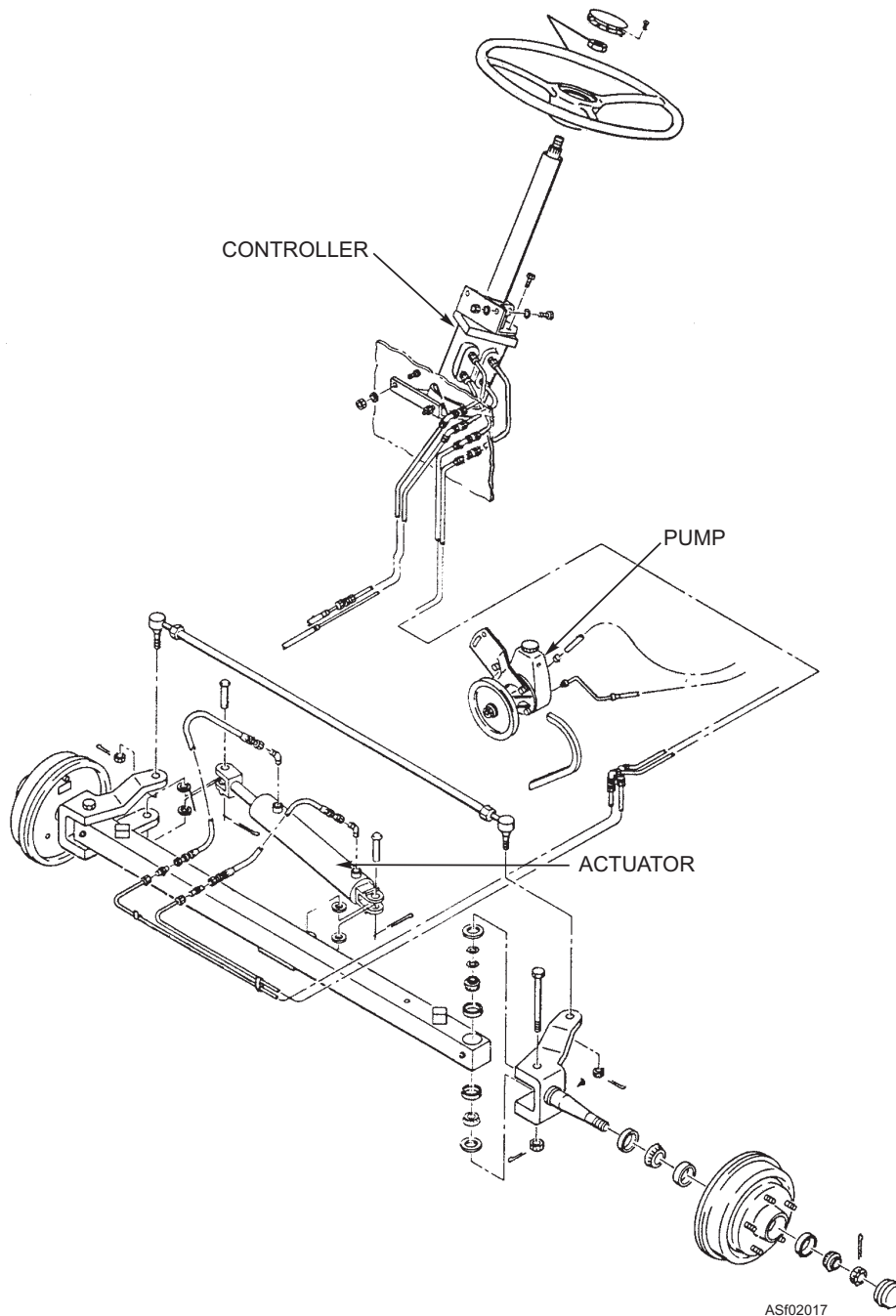

Figure 2-17.—Power steering system.

in manual steering. Because of this, wear of the linkage will normally progress to a dangerous point before the operator typically becomes aware of the problem.

Should hard steering occur, check the pressure of the steering pump to determine if that is the problem. Use a suitable pressure gauge to determine the pressure of the system. Follow the manufacturer's procedure, and compare the results to the specifications in the technical manual. If within limits, adjust the pressure by altering spring tension in the relief valve. If the results are not within limits and cannot be adjusted, a faulty component is indicated, and it should be replaced.

Other Maintenance Procedures

Lubrication involves the greasing and oiling that is performed at the time the entire vehicle is greased. Figure 2-18 shows the tie rod end grease fitting. Consult the manufacturer's service instructions for the proper lubricant to use.

Depending on the steering arrangement, a drag link or idler arm rod may be used in the linkage to connect the pitman arm and the remainder of the steering linkage. This portion of the linkage is usually

constructed so that to remove it from the vehicle, one or both ends must be disassembled or loosened. The adjusting plug (fig. 2-19) is used to remove any free play between the drag link and the connecting parts of the linkage. Occasionally, adjustment of the plug is needed to compensate for wear of the ball and seats or weakening of the spring.

The tie rod is equipped with a ball-type socket at each end to allow for movement of the connecting parts of the steering linkage. These sockets, called TIE ROD ENDS, must be checked for wear or slack. The linkage should pivot at the ball socket without allowing free movement between the socket and ball. A slight drag is considered the optimum condition of the ball joints. In addition to the flexible end connections, the linkage is designed so that an adjustment can be made when performing wheel alignment. The tie rod is normally connected directly to the steering knuckle or spindle arm and used to transmit the steering effort to the wheel via the knuckle or spindle.

You can check worn or improperly adjusted linkage connections by jacking up the front end of the vehicle, grasping each wheel (front and rear of the wheel), and moving the wheel in and out to check for excessive movement. At the same time, you can check

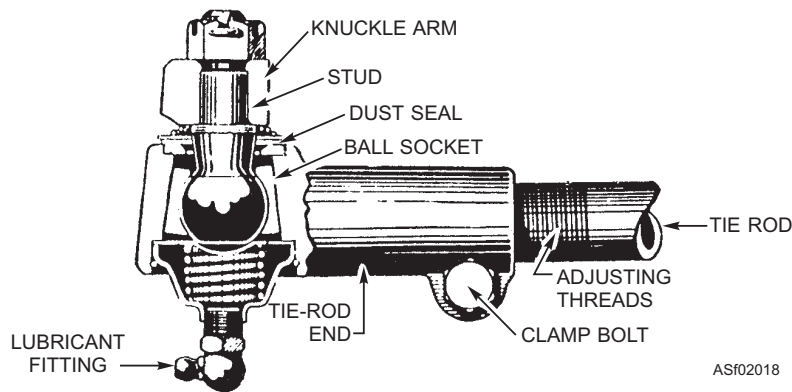

Figure 2-18.—Tie rod end showing clamp bolt and adjusting threads.

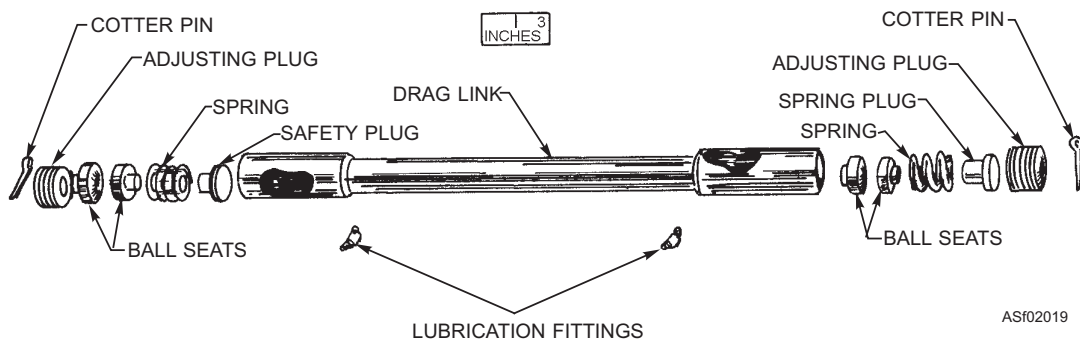

Figure 2-19.—Drag link assembly—exploded view.

for worn steering knuckle parts and loose wheel bearings by grasping the top and bottom of each wheel and shaking it to determine the amount of wobble.

Test the steering gear by watching the pitman arm while someone turns the steering wheel. If considerable movement of the steering wheel is required to set the pitman arm in motion, the steering gear is either worn or out of adjustment and requires adjustment to the manufacturer's specifications.

Adjust the length of the tie rod to increase or decrease the toe-in. If the vehicle has two tie rods, it is necessary to adjust each equally. In figure 2-15, the right-hand tie rod is adjusted for the proper setting. Figure 2-18 shows a cross section of one of the ends.

Before making any adjustments, count the number of exposed threads at the ends of the tie rod. One end of the tie rod has a right-hand thread, and the other end has a left-hand thread that screws into the fitting. Turning the rod in one direction so that more of these threads enter the fitting shortens the rod. Turning the rod in the opposite direction exposes more threads, and the rod becomes longer. Very little turning is required to change the length of the rod.

To increase or decrease toe-in, loosen the clamp bolts and turn the rod in the direction that will give you the proper adjustment. Use a pipe wrench and make one turn at a time. If the tie rod is behind the axle, lengthening the tie rod increases toe-in, and shortening it decreases toe-in. If the tie rod is in front of the axle, then lengthening it decreases toe-in, and shortening it increases toe-in. Always tighten the clamp bolts after making an adjustment.

WARNING

While repairing or adjusting the steering system and the wheel alignment, be sure the vehicle is stationary. At least one wheel should be blocked on both sides, even if the equipment is on a level surface. Aboard ship a four to eight point tie down may be required

Q2-9. Which of the following components keep the front wheels in proper alignment?

1. The pitman arm
2. The tie rod
3. The king pin
4. The connecting rod

Q2-10. The pitman arm connects the steering gearbox to which of the following components?

1. The tie rod ends
2. The king pins
3. The axle
4. The connecting rod

Q2-11. What are the principal parts of a steering gear unit?

1. The worm gear and sector
2. The worm gear and connecting rod
3. The sector and pitman arm
4. The sector and the Recirculating balls

Q2-12. Which of the following conditions can cause excessive play in the steering system?

1. Improper adjustment of the steering gear unit
2. Improper adjustment of the steering linkage
3. Improper adjustment of the brakes
4. Improper wheel alignment

Q2-13. Front-end geometry does NOT include which of the following terms?

1. Caster
2. Camber
3. Pinion tilt
4. Pivot inclination

Q2-14. Which of the following statements best describes wheel caster?

1. The number of turns required to adjust the connecting rod one inch
2. The number of inches the front wheel points in towards the center of the unit
3. The number of degrees the wheel is pointed in or out at the top
4. The number of degrees the steering knuckle is tilted to the rear or front

BRAKES

LEARNING OBJECTIVES: Identify the types of brake systems. Identify procedures for inspecting, checking, testing, troubleshooting, and repairing brake systems. Describe the relationship between the brake system and the chassis.

Efficient, reliable brakes are just as important to powered support equipment as the engine. They are required not only to stop the vehicle, but to stop it in as short a distance as possible, and then hold it in place after it is stopped. Because brakes are expected to decelerate a vehicle at a faster rate than the engine can accelerate it, they must control a greater power than that developed by the engine.

The requirement for good brakes is not limited to powered equipment. Nonpowered equipment, such as oxygen- and nitrogen-servicing trailers, air-conditioning units, bomb trailers, and work stands, requires some type of braking system. While the primary purpose of the brakes on powered equipment is to stop the vehicle, their primary purpose on nonpowered equipment is to secure the equipment after it has been pushed or towed to the desired location.

A brake absorbs mechanical energy by transferring it into heat through friction. Friction is the resistance to relative motion between two surfaces in contact with each other. Thus, when a stationary surface is forced into contact with a moving surface, the resistance to relative motion, or the rubbing action between the two surfaces slows down the moving surface.

In nearly all brake systems, the brake drums provide the moving surface, and the brake shoes are the stationary surface. The friction between the brake drum and the brake shoe slows the wheel, and the friction between the tires and the road surface brings the vehicle to a complete stop.

This braking action is accomplished through rods and cables in a mechanical brake system, a liquid coupling (brake fluid) in a hydraulic brake system, and air pressure in a pneumatic brake system. A combination of hydraulics and pneumatics (or vacuum) is used to operate the brakes of some equipment. Although electrical systems are used to operate some brake systems, they are not commonly used on support equipment.

The AS is responsible for the maintenance of the brakes and brake systems on all support equipment. This includes servicing, inspecting, adjusting, and repair. To accomplish these tasks, you must have a thorough knowledge of the various types of brakes and brake systems and how they operate.

TYPES OF BRAKES

Powered support equipment is equipped with either two- or four-wheel brakes. In either case, individual brake assemblies are provided for each braking wheel and are operated by a foot pedal. Powered equipment also has an emergency or parking brake, which is operated by a separate pedal or lever. This may be a separate brake assembly, such as a transmission parking brake, or it may simply be a secondary method of controlling the wheel brake assemblies. The brake assemblies on nonpowered equipment are similar to those on powered equipment, but are usually provided only on two wheels.

Drum Brakes

Drum-type brake assemblies may be classified into two general types—external contracting and internal expanding. There are different designs of the internal expanding type, of which the conventional shoe is the most common type used on support equipment. The expander tube brake, another design of the internal expanding type, is used on some types of equipment. There are three types of drum brake assemblies—external contracting, internal expanding (shoes), and internal expanding (expander tube).

EXTERNAL CONTRACTING BRAKES.—

External contracting brakes (fig. 2-20) are rarely used for wheel brakes. However, they are often used as parking brakes. Figure 2-21 shows the external contracting brake used as a transmission parking brake. The brake drum is located at the point where the drive shaft is attached to the rear of the transmission.

INTERNAL EXPANDING (SHOE).—Internal expanding brakes are used almost exclusively as wheel brakes. This type permits a more compact and economical construction. The brake shoe and brake operating mechanism are supported on a backing plate or brake shield, which is attached to the axle flange in the case of nondriving axles or to the axle housing in the case of driving axles. The brake drum, attached to the rotating wheel, acts as a cover for the shoe and operating mechanism and furnishes a frictional surface for the brake shoes. Figures 2-22 and 2-23 show the arrangement of the brake shoe and operating mechanism of a typical wheel brake assembly.

In operation, the brake shoe of an internal expanding brake is forced outward against the drum to

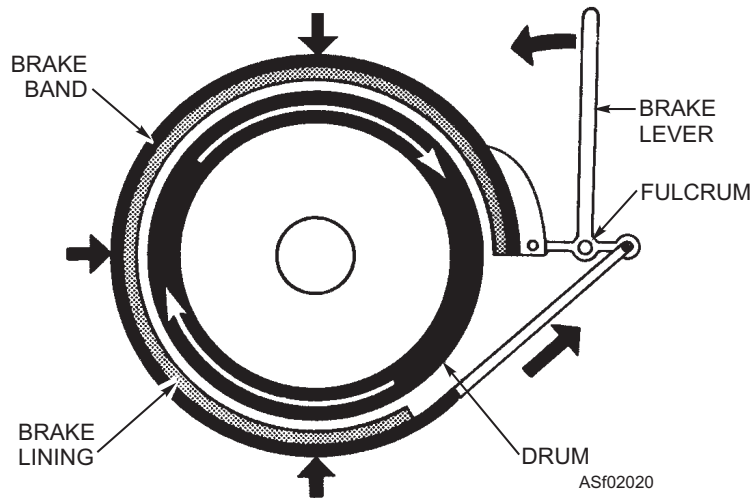

Figure 2-20.—External contracting brake.

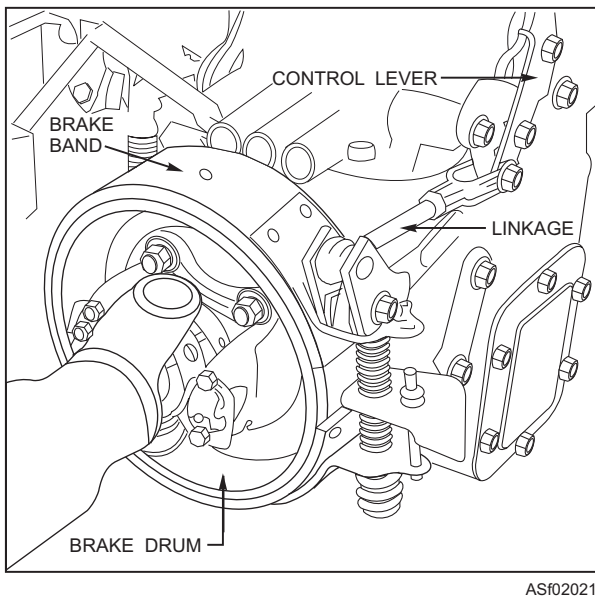

Figure 2-21.—External contracting transmission parking brake.

produce the braking action. One end of the shoe is hinged to the backing plate by an anchor pin, while the other end is unattached and can be moved in its support with the operating mechanism. When force from the operating mechanism is applied to the unattached end of the shoe, the shoe is forced (expanded) against the drum and brakes the wheel. A retracting spring returns the shoe to the original position when braking action is no longer required.

The brake-operating linkage alone does not provide sufficient mechanical advantage for positive braking. Some means of supplementing the physical application of the braking system must be used to increase pressure on the brake shoes. A self-energizing

action is very helpful in accomplishing this, once setting of the shoes is started by physical effort. While there are variations of this action, it is always obtained by the shoes themselves, which tend to revolve with the revolving drum.

Figure 2-24 illustrates the self-energizing action of a brake shoe. As shown, the drum is revolving counterclockwise. When the shoe is forced against the drum, it tends to rotate with the drum. As the initial braking pressure is increased on the cam, the wedging action increases and the shoe is forced more tightly against the drum to increase friction. This self-energizing action results in more braking action than could be obtained with the actuating force alone. Brakes making use of this self-energizing principle to increase pressure on the braking surface are known as servo brakes. (Servo is the action or device used to convert a small movement into a greater movement or force.)

The operator controls the self-energizing action; that is, as the operator adds pressure to the brake pedal, the self-energizing action increases. Thus, it is most important that the operator control the total braking action at all times. The amount of self-energizing action available depends mainly upon the location of the anchor pin. This is determined by the manufacturer and is located at the point outward of the braking surface where the operator has the maximum control of the braking action. If the anchor pin is located too near the center of the drum, the shoe will automatically lock when the brakes are initially applied.

When two shoes are anchored on the lower part of the brake shield, self-energizing action is effective on only one shoe. The other shoe tends to revolve away from its pivot, which reduces its braking action. When

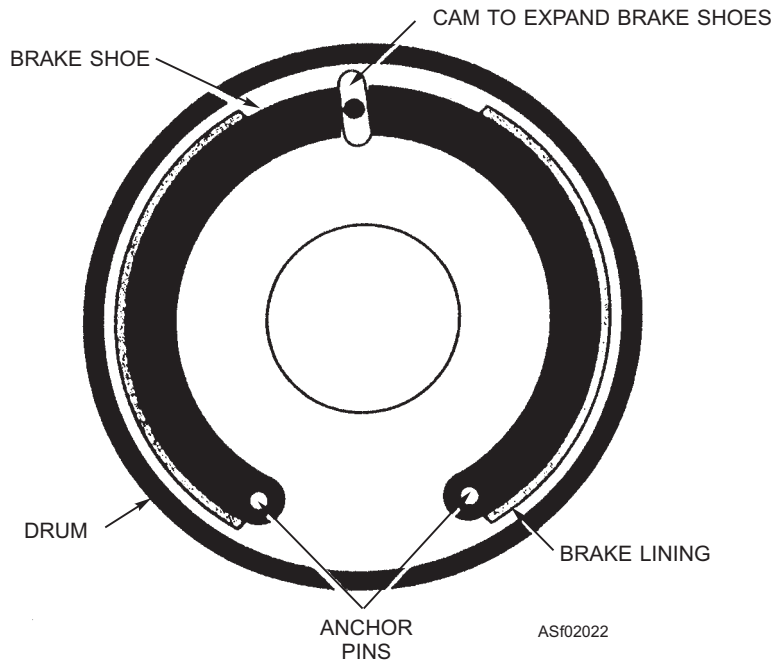
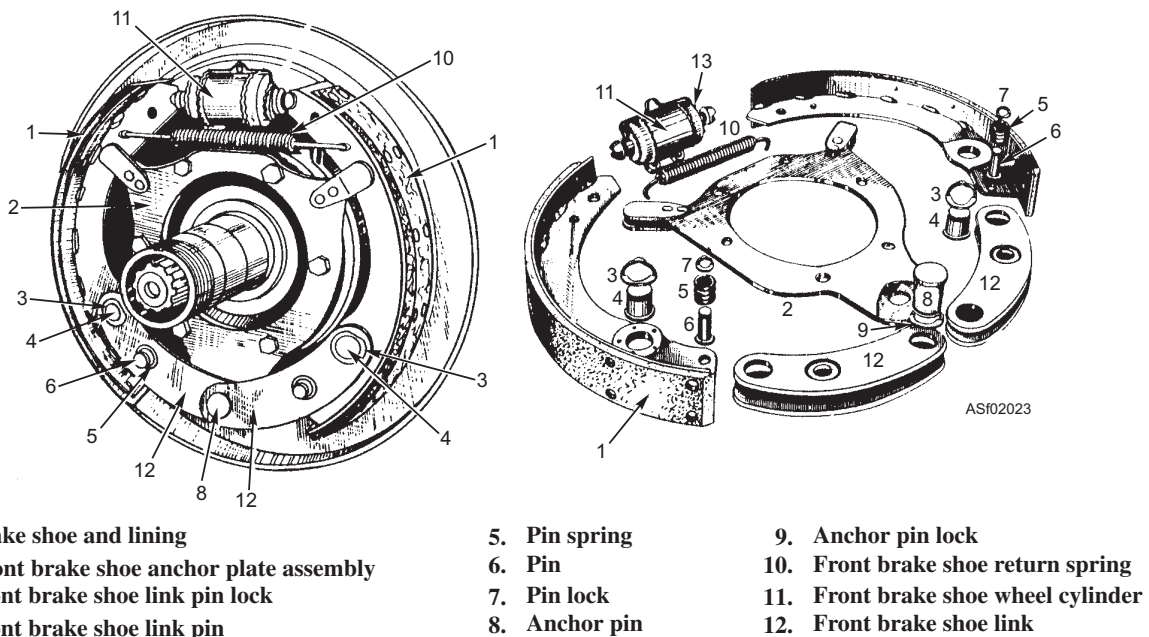

Figure 2-22.—Internal expanding brake.



- | | | |
|---|---------------|-------------------------------------|
| 1. Brake shoe and lining | 5. Pin spring | 9. Anchor pin lock |
| 2. Front brake shoe anchor plate assembly | 6. Pin | 10. Front brake shoe return spring |
| 3. Front brake shoe link pin lock | 7. Pin lock | 11. Front brake shoe wheel cylinder |
| 4. Front brake shoe link pin | 8. Anchor pin | 12. Front brake shoe link |

Figure 2-23.—Wheel brake assembled and exploded view.

the wheel is revolving in the opposite direction, the self-energizing action is produced on the opposite shoe.

With the arrangement shown in figure 2-25, both shoes are positioned to develop self-energizing action with forward movement of the vehicle. For this reason, the arrangement is used mostly on the front wheels where maximum braking effort is required during normal forward movement. In reverse, this arrangement would not have any servo action.

Two shoes are usually arranged so that self-energizing action is effective on both, regardless of the direction of drum rotation. This is accomplished by pivoting the shoes to each other and leaving the pivot free of the brake shield. The only physical effort required is for operating the first, or primary, shoe. Both shoes then apply additional pressure to the braking surfaces with no increase in the pressure on the operating linkage. The anchor pins are fitted into slots in the free ends of the brake shoes.

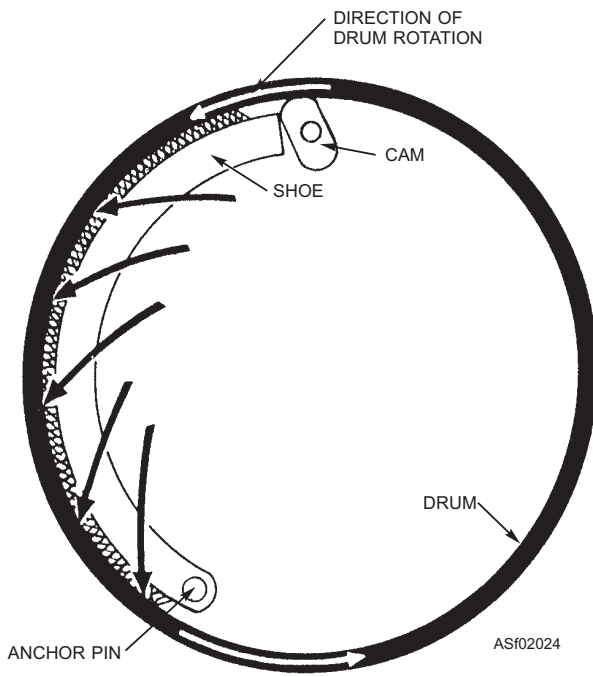

Figure 2-24.—Brake shoe self-energizing action.

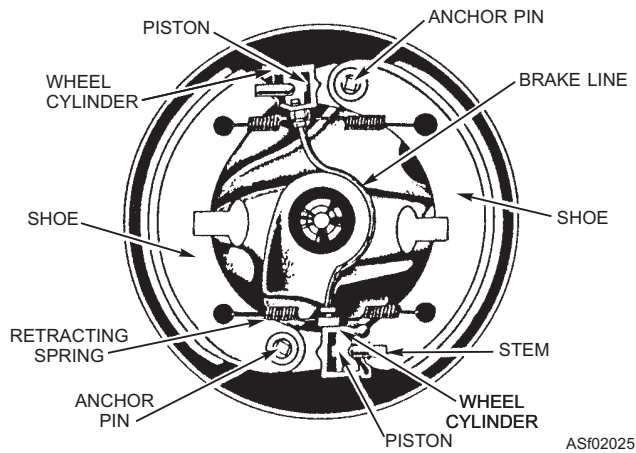

Figure 2-25.—Front wheel brake assembly.

This method of anchoring allows the movement of the shoes necessary to expand against the drum when the shoes are forced against the drum, and the self-energizing action of the primary shoe is transmitted through the pivot to the secondary shoe (fig. 2-26). Both shoes tend to revolve with the drum and wedge against the drum through the one anchor pin. The other anchor pin causes a similar action when the wheel is revolving in the opposite direction.

Disc Brakes

The disc brake assembly (fig. 2-27) consists of a metal disc and caliper assembly. The disc, which is bolted to the wheel hub, rotates with the wheel of the

vehicle. The caliper assembly, which remains stationary, attaches to the steering knuckle on the front wheels or to the rear axle housing on the back wheels.

The disc is usually solid when used on a lightweight vehicle and vented (for cooling) on a heavy vehicle. Both sides of the disc are machined to provide a smooth friction surface. The caliper contains one or more hydraulic pistons, which cause the brake shoes (one on either side of the disc) to squeeze the disc in a viselike manner.

Figure 2-28 illustrates the operation of a typical disc brake assembly. In actual application, the brake shoes (friction pads) are held in light contact with the disc when the brakes are released by a piston return spring.

Some disc brake shoes have telltale tabs that contact the disc when lining wear has reached a predetermined point. This results in a scraping noise when the vehicle is operated, warning the operator that the brake shoes are badly worn and should be replaced.

Disc brakes require no adjustment. However, you will occasionally have to add brake fluid to the master cylinder reservoir, which supplies fluid for the disc portion of the braking system. This is necessary because the piston return springs, by keeping the shoes against the disc as wear occurs, create a larger cavity for the fluid in the caliper assembly. A booster assembly is often used in disc brake systems, as they have no self-energizing feature. Some features of the disc brake make it more desirable than the drum brake; namely, braking action is instantaneous when pressure is applied to the caliper assembly, fading caused by the heat is eliminated, and the brakes are not affected when water is splashed onto the disc and linings.

SERVICING DISC BRAKES.—Anytime a vehicle with disc brakes is scheduled for maintenance, the disc should be inspected for scoring and hard spots. Slight scoring results from normal braking. A disc that is scored less than 0.015 inches can be used without machining if the overall thickness of the disc is still within the manufacturer's specifications. Heavy scoring or hard spots require the disc to be machined.

The rust ridges that build up as wear occurs are of no concern unless new shoes are to be installed. Placing new shoes on a disc that has rust ridges causes the shoes to seat on the ridge, resulting in poor braking. These ridges should be removed by grinding or machining prior to installing new shoes. A special lathe is normally used for machining discs. However, if

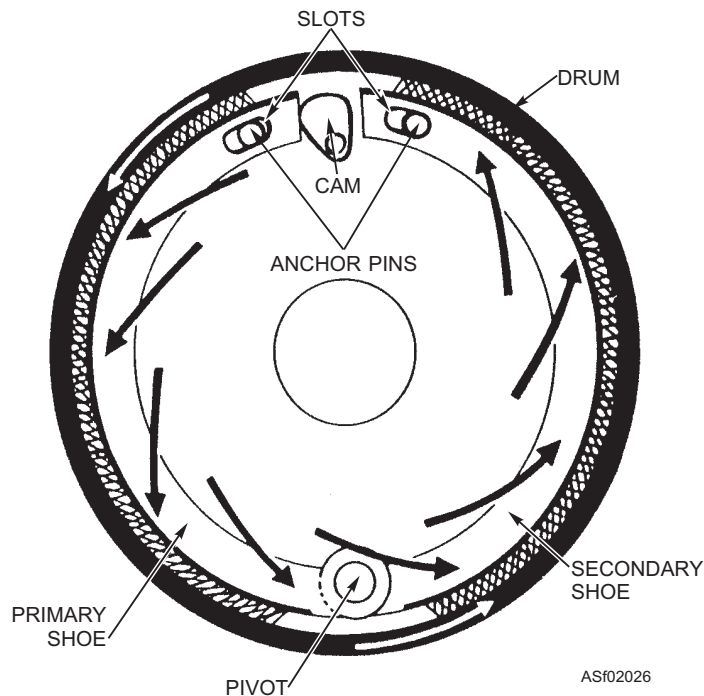

Figure 2-26.—Primary and secondary brake shoes—self-energizing action.

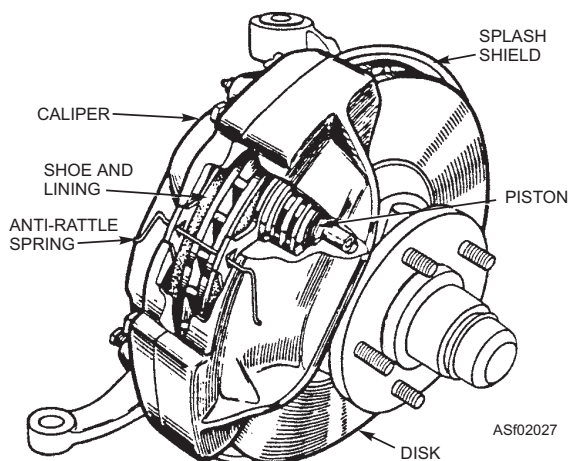

Figure 2-27.—Disc brake assembly.

none is available, the metal lathe in the machine shop and a grinding attachment will do the job.

A test should be made when shoes are replaced to determine if the disc has excessive runout (out of round) or thickness variation. Either condition will cause erratic braking similar to that caused by a warped drum on conventional brakes.

Runout or wobble of the disc as it rotates must be checked with a dial indicator. Thickness variation is determined by measuring the thickness of the disc in at least three places approximately 1 inch from the outer edge of the disc. Should either of these tests

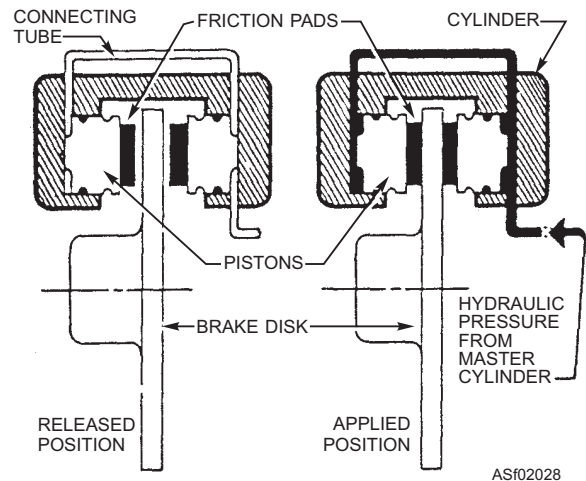

Figure 2-28.—Sectional view of a disc brake in released and applied position.

indicate a faulty disc, the disc must be machined. If it is worn excessively, it must be replaced.

REPLACING DISC BRAKE LININGS.—Disc brakes have flat linings bonded to a metal plate or pad (shoe). The pad is not rigidly mounted inside the caliper assembly, thus it is said to float. The pads are held in position by retainers or internal depressions (pockets machined into the caliper).

Figure 2-29 shows a disc brake assembly. To remove brake pads, raise the front of the vehicle and remove the wheels. Next, remove approximately two-thirds of the fluid from the master cylinder and

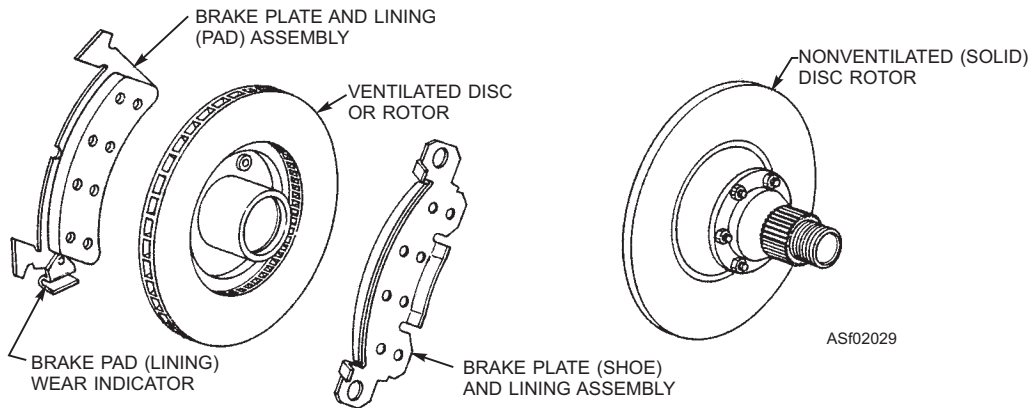
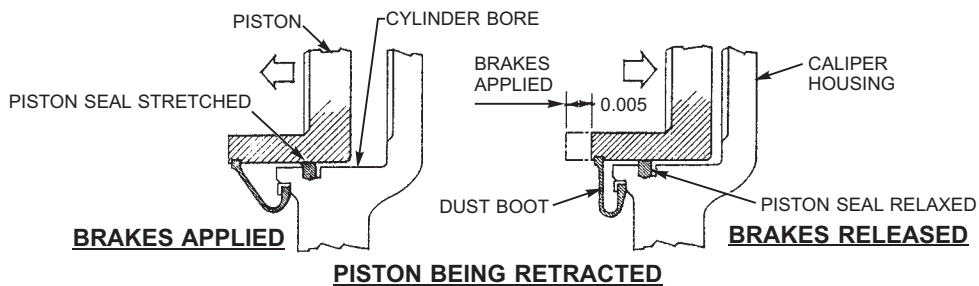
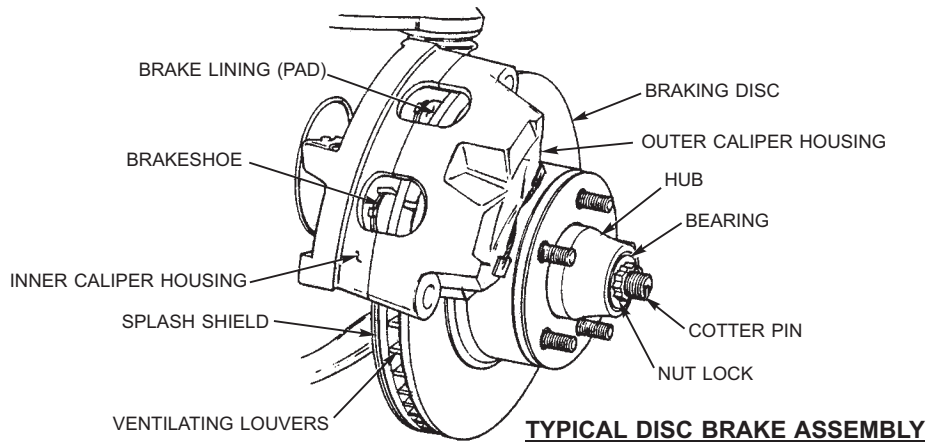

Figure 2-29.—Disc brake assembly.

discard. Do not remove all of the fluid or bleeding of the system will be required on reassembly. Then, remove the shoes following the manufacturer's procedure. The procedure may vary depending on the manufacturer and model. Some models allow removal of the shoes with the caliper mounted on the vehicle, while other designs require removal of the caliper before the shoes can be extracted. In either case, the pistons should be bottomed in the bores of the caliper assembly (fully pressed into the caliper) to release any tension on the shoes. This allows clearance for any rust buildup (ridge) at the outer edge of the disc.

NOTE: The rust buildup near the edge of the disc may have to be removed for the new shoes to seat properly on the disc.

The next step is to remove the old shoes and insert the new shoes. Remount the caliper or replace the shoe retainers, torquing all bolts according to the manufacturer's specifications. Refill the master cylinder and apply the brakes a few times. Then, check for any leaks at the pistons in the caliper. If there are no leaks, replace the wheels and lower the vehicle. A road test should be made to insure that the brakes are working properly and also to seat the new shoes on the disc. Several (3 or 4) heavy brake applications at approximately 3 to 5 miles per hour will work. If the brakes function normally after the braking test, the job is complete.

SERVICING CALIPER ASSEMBLIES.— Servicing disc brake caliper assemblies usually

involves the replacement of pistons, seals, and dust boots. To perform this type of service, it is necessary to remove the caliper assembly from the vehicle. The procedures for this type of service will be listed in the manufacturer's maintenance manual.

Internal Expanding (Expander Tube) Brakes

The expander tube brake is used on some types of support equipment. For example, the A/S32K-1C/1D weapon loaders are equipped with expander tube brakes. The technical manual frequently refers to this brake as the aircraft-type expander tube brake because the expander tube brake was designed originally for aircraft. Several models of naval aircraft are equipped with brakes of this type.

An exploded view of an expander tube brake is shown in view A of figure 2-30. View B shows the brake completely assembled, and view C shows a cross-sectional view of the assembled brake. The main parts of the brake are the spider, frames, expander tube, brake blocks, and return springs.

The spider, sometimes referred to as a flange or torque flange, is the basic unit around which the brake is built. The main part of this spider is secured to the wheel support. The detachable metal frames form a groove around the outer circumference into which the expander tube, brake blocks, springs, and so on, are fitted.

The expander tube is made of neoprene reinforced with fabric, and has a metal nozzle through which hydraulic fluid enters and leaves the tube.

The brake blocks are made of materials quite similar to that used in the linings of shoe-type brakes. The actual braking surface is strengthened by a metal backing plate. The blocks are held in place around the spider and are prevented from rotating by the torque bars, which are secured to the frames. The size of the brake assembly varies with different types of equipment. As the size of the assembly changes, the number of blocks per assembly changes.

The brake return springs are semi-elliptical or half-moon in shape. One is fitted between each separation in the brake blocks. The ends of the springs are designed to fit into slots in the brake frames. The bowed center section of the spring pushes inward, holding the blocks firmly against the expander tube (fig. 2-30, view C). This prevents the blocks from dragging against the drum when the brake is released.

The expander tube brake assembly is hydraulically operated and may be used with any of the conventional hydraulic brake systems. When the brake pedal is applied, the fluid is forced into the expander tube. The spider and frames prevent expansion inward or to the sides. Thus, the pressure of the fluid in the tube overcomes spring tension and forces the blocks radially outward against the brake drum, creating friction. The tube shields prevent the expander tube from extruding between the blocks, and the torque bars prevent the blocks from rotating with the drum. Friction created by the brake is directly proportional to brake line pressure.

When the brake pedal is released, the return springs return the blocks inward, compressing the expander tube and forcing the fluid back to the brake control unit.

BRAKE LININGS

There are several important qualities that are desired of the material for brake linings. First, of course, it must have high frictional qualities. Second, the material must have the ability to withstand high temperatures. Since there is a lack of cooling facilities around the brake assembly, it is necessary that the brake lining be able to dissipate the heat rapidly. In addition, the material must be durable and moisture-resistant.

The two main types of brake linings are organic and metallic. One form of organic lining is woven material composed of asbestos fiber, cotton fibers, and copper or bronze wire. It is treated with a mineral-based chemical to resist the effects of oil and water. It is then pressed and undergoes a baking process that compresses the fibers into a dense material, helping the lining to resist the effects of heat from friction. This material has a very high frictional quality but a low rate of heat transfer or dissipation. Also, it is severely affected by oil, even after treatment. Therefore, the woven material is used mostly on transmission brakes.

Another form of the organic type is the molded lining. This lining is made of a dense, hard, compact material, and is cut into various forms to fit different types of shoes. Generally, the compact materials are resins and mineral fibers, mixed as a semi-liquid, molded, pressed, and baked. The result is an extremely dense material. Very often copper or bronze wires are added to the mixture.

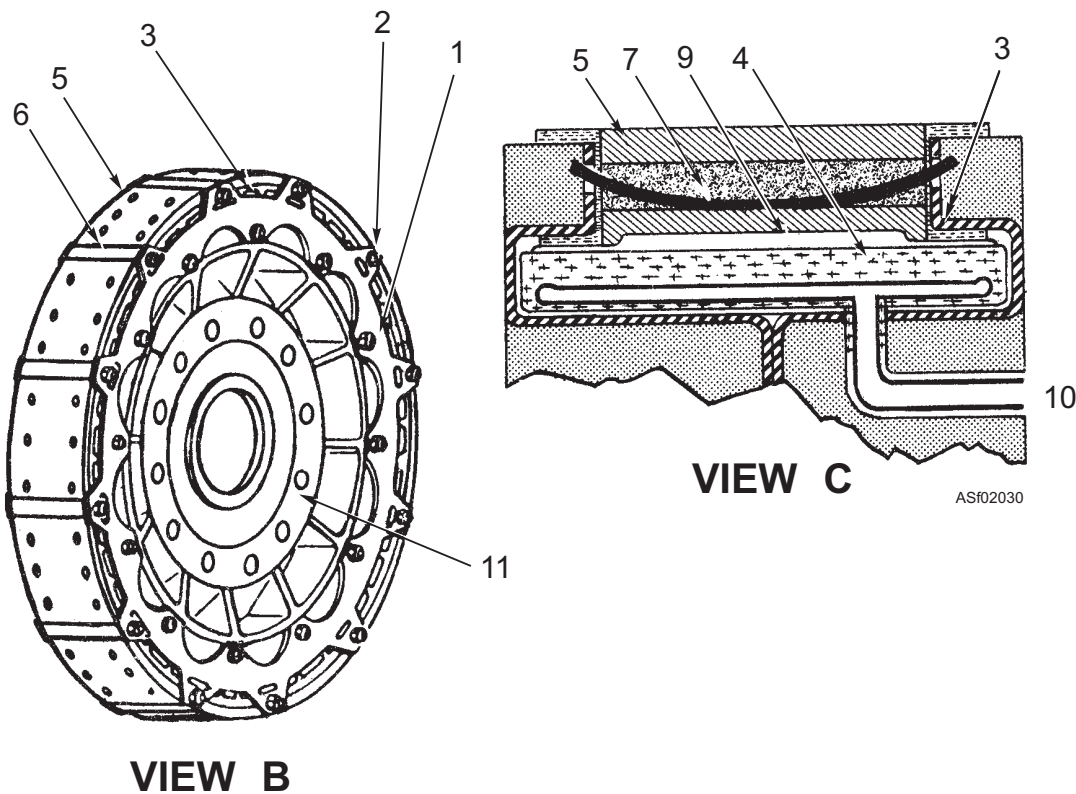
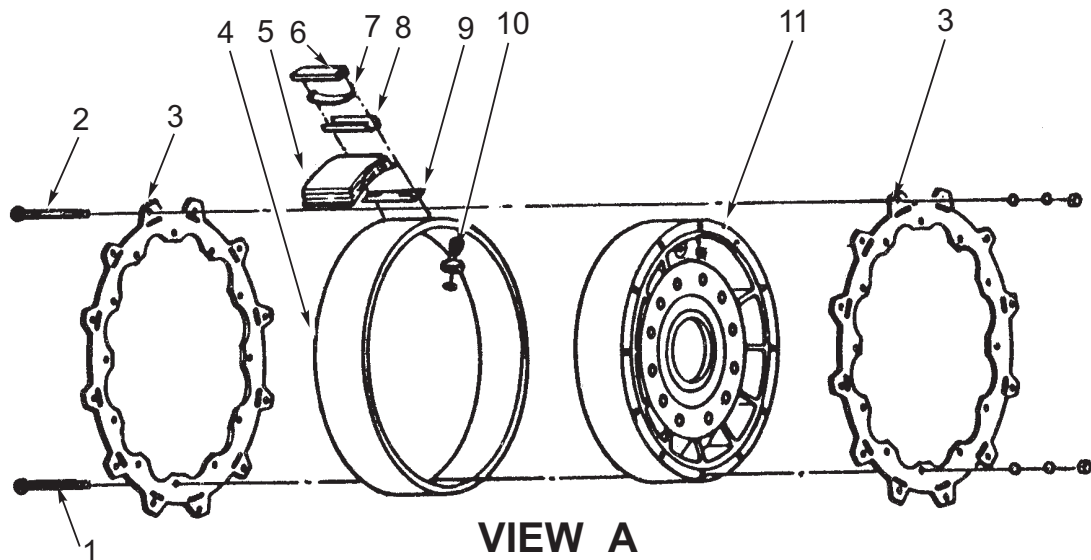

- | | | | |
|---------------------|------------------|-------------------------|------------|
| 1. Brake frame bolt | 4. Expander tube | 7. Return spring | 10. Inlet |
| 2. Torque bar bolt | 5. Brake block | 8. Return spring shield | 11. Spider |
| 3. Frame | 6. Torque bar | 9. Tube shield | |

Figure 2-30.—Expander tube brake. A. exploded view; B. assembled view; C. cross-sectional view.

The frictional qualities of this type of lining are lower because of the smooth surface. However, this type of lining dissipates heat rapidly and wears longer than the woven type. As a result, the molded lining is more suitable for application on the wheel brakes than are the woven types. Because of the density of the molded material, it is less affected by oil and water.

Metallic brake linings are made of finely powdered iron, copper, or graphite, and lesser amounts of inorganic fillers and friction modifiers. The mixture is put through a molded block process and compressed and baked into the desired form. Metallic brake linings are used when extreme braking conditions exist. The frictional characteristics of metallic linings are more constant than those of organic linings.

The lining may be secured to the shoes by riveting or by a bonding process in which the linings are glued to the shoe. In the bonding process, pressure and heat are applied to make a secure bond between the lining and the shoe. The bonding process allows the lining to be worn comparatively thin without danger of cutting or scarring the drum. When brass rivets are used to secure the lining to the shoe, the lining must be replaced when it is worn to a specified amount to keep the rivets from scarring the drum.

WARNING

Many types of linings contain asbestos, and dust from normal wear may accumulate in the brake drum assembly. For this reason, special procedures are followed, including the wearing of a suitable respirator, when working on asbestos brakes. Do not use compressed air to blow out the drum or brake assembly, and use a suitable solvent for cleaning parts. Remember that asbestos dust is treated as hazardous waste.

BRAKE DRUMS

Brake drums are made of pressed steel, cast iron, or a combination of the two metals. Cast iron drums dissipate the heat generated by friction more rapidly than steel drums, and have a higher coefficient of friction with any particular brake lining. However, cast iron drums are heavier and are not as strong as steel. Quite often, steel drums have a cast iron liner fused into them to provide the necessary strength and heat-dissipating qualities (fig. 2-31). To further add to the strength and heat dissipation qualities, cooling ribs are sometimes used on the outside of the drums.

BRAKE ADJUSTMENTS

Due to normal wear of the brake linings, brake assemblies (except for disc brakes) require periodic adjustment. Normal wear can result in excessive clearance between the lining and drum and can lead to poor and uneven braking. One possible outcome of poorly adjusted brakes is that during hard braking, one wheel may lock before the others are stopped, causing the driver to lose steering control of the vehicle. It is important, therefore, that brake adjustments be made to provide equal distribution of brake action to all wheels.

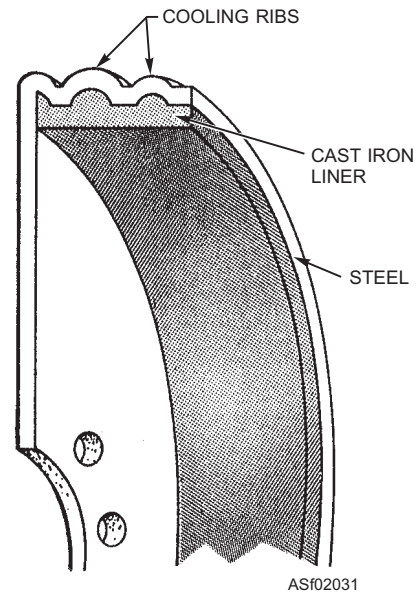

Figure 2-31.—Sectional view of a brake drum.

When a brake is correctly adjusted, the lining attached to the brake shoes fits evenly against the brake drums when the brakes are applied. Also, the lining will be free of the drum when the brakes are released. The linings must not drag against the drum, yet they must be near enough to give the proper leverage between the operating mechanism and the friction surfaces. The backing plate of some brake assemblies contains small slots for the purpose of checking these clearances with a feeler gauge.

Most automobiles and some support equipment have a mechanism that automatically adjusts the brakes. The adjustment takes place when the brakes are applied as the vehicle is moving backward. As the brakes are applied, friction between the primary shoe and the brake drum forces the primary shoe against the anchor pin (fig. 2-32). Then, hydraulic pressure from the wheel cylinder forces the upper end of the secondary shoe away from the anchor pin and downward. This causes the adjuster lever to pivot on the secondary shoe so that the lower end of the lever is forced against the sprocket on the adjuster screw. If the brake shoes have worn enough, the adjuster screw turns a full tooth. This spreads the lower ends of the brake shoes a few thousandths of an inch, or enough to compensate for the shoe wear.

Some brake assemblies and even autoadjusting brakes require first time adjustment in the same manner as nonself-adjusting brakes. Many have a slot in the rear of the backing plate to allow a thin blade tool to turn the star wheel. Brakes with this type of adjustment require you to turn the star wheel until the

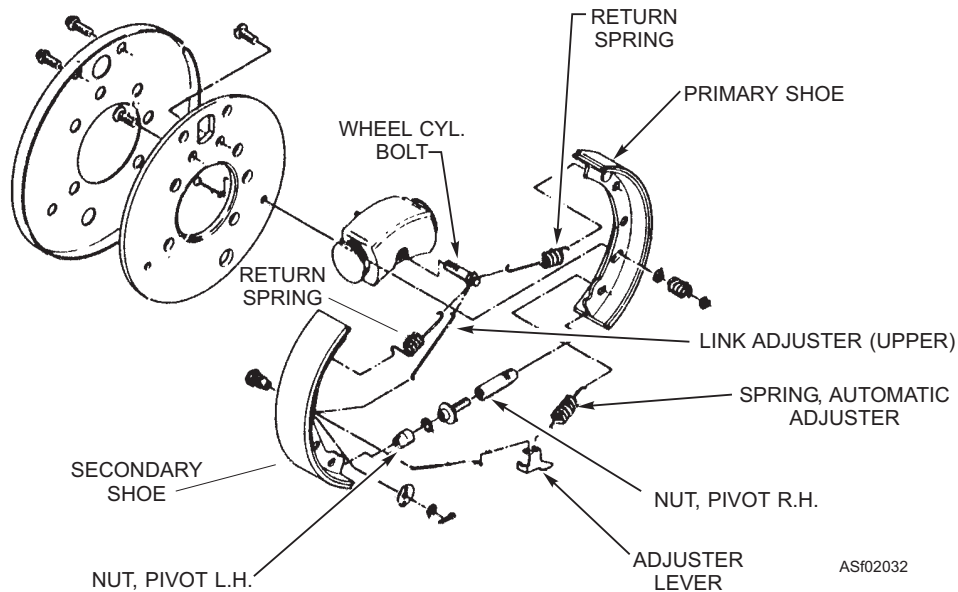

Figure 2-32.—Brake assembly, self-adjusting.

wheel is locked by the brake shoes, and then back off the star wheel a certain number of notches or until no dragging noise is heard between the drum and the shoes.

NOTE: Unless thoroughly familiar with the type of brakes to be adjusted, you should carefully follow the procedures outlined in the manufacturer's service manual.

WARNING

When working on brakes it is usually necessary to jack up the vehicle. When doing so, be sure to observe these precautions: (1) Place the proper rated jack stands under the vehicle when it is raised. (2) Never work under a unit using a jack only. (3) Before using a hydraulic jack, make sure it is filled with fluid and has no apparent leaks. (4) Aboard ship, tie or chain the unit down while it is on jack stands.

BRAKE INSPECTION AND MAINTENANCE

Frequent brake inspections are necessary to ensure safe operating conditions. Brake inspections are not made just to comply with regulations but to ensure safety of personnel and equipment. Defective brakes are a contributing factor to many accidents that might have been avoided with frequent and thorough brake inspections.

Like most components of support equipment, brake assemblies require both operational and visual

inspections. The interval of these inspections is usually specified in the applicable instruction manual and maintenance requirements cards (MRCs). An operational check is usually conducted daily.

On nonpowered equipment, this can be accomplished by attempting to move the vehicle with the brakes set. Similarly, emergency or parking brakes of powered equipment can be checked by applying power to the wheels with the brakes set.

A road test is usually conducted for the operational check of the wheel brakes of powered equipment. The brakes must stop a moving vehicle in a reasonable distance. After the vehicle is stopped, the brake marks on the roadway should be inspected to see if there is an indication of any one wheel braking more than the others. If the brakes do not stop the vehicle within the prescribed distance, are not equalized, grab, or do not hold, the necessary adjustments or repairs must be made.

The wheel brake assembly must be visually inspected at specified intervals. To do this, you must remove the wheel and brake drum. Clean the dust and crud out of the assembly, taking care not to breathe the asbestos dust. You should use an asbestos vacuum cleaner or a wet spray-type cleaner and respirator. Ensure you meet all EPA, LOCAL COMMAND, and NAVOSH REQUIREMENTS prior to doing brake work.

The brake assembly should be checked for loose or broken brake shoe retracting springs, worn clevis and cotter pins in the brake operating mechanism, and indications of grease or oil leaks at the wheel bearing

grease retainer. All parts of the self-adjusting brake systems must be free of rust and corrosion for them to work properly. While checking springs, clevis and cotter pins, you should clean the star adjuster threads with a hand-held wire brush and apply a thin film of oil to ensure proper operation.

In the case of hydraulic brake systems, the hydraulic brake cylinder should be checked at this time. The condition of the brake linings and brake drum must be checked thoroughly at this time.

Brake linings that are riveted to the brake shoe should be replaced if worn to less than 40 percent of their original thickness. Also, the shoes must be replaced if a rivet head is riding or is about to make contact with the brake drum. If the lining is bonded to the shoes, the remaining lining must be at least 1/16-inch thick.

Brake linings that pass inspection for wear, must be securely fastened to the brake shoes and free from grease and oil. Small grease or oil spots can be removed from the lining with an approved cleaning fluid. Do not use a petroleum-based cleaner, as it leaves an oily residue on linings. Most shops recommend dry cleaner solvent. If the lining is saturated with grease or oil, it must be replaced. The source of grease and oil on the lining must be located and remedied.

WARNING

When using cleaners, you must wear safety glasses for eye protection.

If the brake lining needs replacing, the brake shoes must be removed. Before the shoes are removed, the front and rear shoes should be marked so that they will be replaced in their original position. The brake shoes may be removed by first removing the brake shoe return spring and the anchor pin locks. (See fig. 2-23.)

For good braking action, brake drums should be perfectly round and have a uniform surface. Excessive pressure exerted by the brake shoes and heat developed by their application often cause the brake drums to become out of round. Drums should be inspected for distortion, cracks, scores, roughness, and excessive glaze, which lowers braking efficiency.

Light score marks can be removed with emery cloth. When the surface becomes badly scored or out of round, it may be reground in a lathe to a true and smooth surface. Excessive grinding will remove too

much material from the drum, leaving it too thin and weak. (All drums are stamped with the maximum allowable area to be removed.) When this occurs, the drum must be replaced. Also, a drum that is cracked or badly distorted should be replaced.

BRAKE SYSTEMS

Although brake assemblies and brake drums are similar on all equipment, the operating mechanisms may differ greatly. The two most common types of brake systems used on support equipment are mechanical and hydraulic.

Mechanical Brake Systems

Brakes operated entirely by mechanical linkages from the brake pedal or lever are called mechanical brakes. The mechanical linkages may consist of levers, rods, cables, or any combination of these.

APPLICATION.—Equalizing brakes, so that all brakes will be applied at the same time, has always been a problem of mechanical brake systems, particularly on vehicles with brakes on all four wheels. For this reason, mechanical brake systems are seldom used for wheel brakes on powered support equipment. They are used, however, for transmission or parking brakes on these vehicles. In fact, most external contracting brakes are operated by mechanical systems. Mechanical brakes will stay set better than hydraulic brakes, so they are very good for holding a parked vehicle.

In regard to support equipment, the major use of mechanical brake systems is on nonpowered equipment. Almost all items of nonpowered equipment that require brakes are equipped with some form of mechanical brake system.

COMPONENTS AND OPERATION.—Figure 2-33 illustrates a typical mechanical system for the operation of parking or emergency brakes. This is simply a secondary means of controlling the rear wheel brakes. Variations of this arrangement are used to operate the parking brakes on some powered support equipment.

A cable assembly is the main working element of this system. A single cable connects the control lever to the intermediate lever and spreader. From here, two cables complete the connection to the two rear wheel brake assemblies. Large portions of the cable slide within a flexible conduit. This conduit not only serves

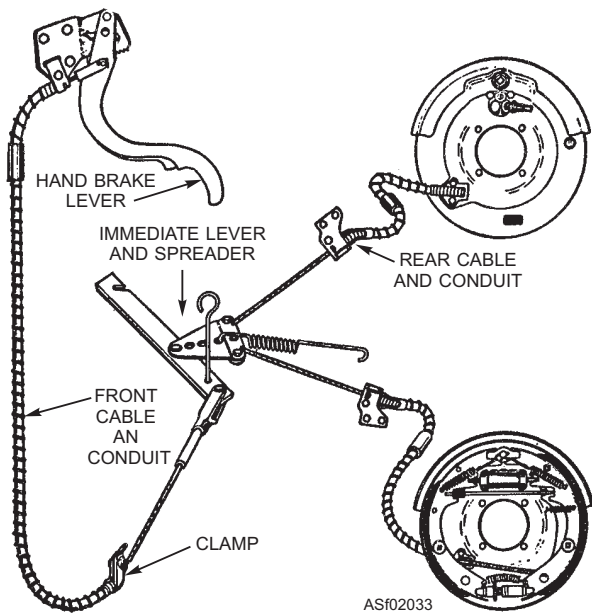

Figure 2-33.—Mechanical brake system—cables.

as a protective housing for the cable but also provides a means for securing the cable to the frame with clamps.

When the brake lever is pulled, the cables move to operate levers in the two rear-wheel mechanisms. The levers, as they operate, force the brake shoes apart and in contact with the drum. The intermediate lever and spreader equalize the tension of the two cables to the brakes. This action, in turn, tends to equalize the braking action of the two brakes. When the hand lever is moved in the opposite direction, the cable moves and releases the brakes.

Transmission parking brakes (fig. 2-21) are usually operated by a similar cable mechanism. However, only a single cable, such as the one labeled “front cable and conduit” in figure 2-33, is necessary for this operation.

Cable assemblies are also used to operate the brakes on some nonpowered support equipment. However, many of this type of equipment are provided with mechanical brake systems similar to the arrangement shown in figure 2-34. To apply the brakes, the brake lever is moved to the right, which, in turn, moves the front rod forward. This rotates the cross shaft clockwise, moving the rear rods forward. This action rotates a cam in each brake assembly (fig. 2-22), forcing the brake shoes apart and in contact with the drum. The brakes are released when the hand lever is moved in the opposite direction.

There are many variations of this arrangement found on support equipment. Cables are sometimes used instead of the front and rear rods. On some equipment the hand lever and cross shaft may be located directly over the wheels. The control device on some equipment may be a foot pedal rather than a hand lever.

On some models of towed equipment, the control linkage for the brakes is attached to the tow bar. With the tow bar in the horizontal position, the brakes are released. When the tow bar is placed in the vertical position, the linkage moves and applies the brakes. These models are usually equipped with a hand lever or foot pedal to apply the brakes when the tow bar is in the horizontal position.

INSPECTION AND MAINTENANCE.—Mechanical brake systems require very little maintenance; however, they must be inspected periodically. Inspections include an operational check of the control device and visual inspection of the mechanical linkage. You should pay special attention to such possible problems as frayed cables, bent rods and shafts, and loose fittings and clamps. The entire

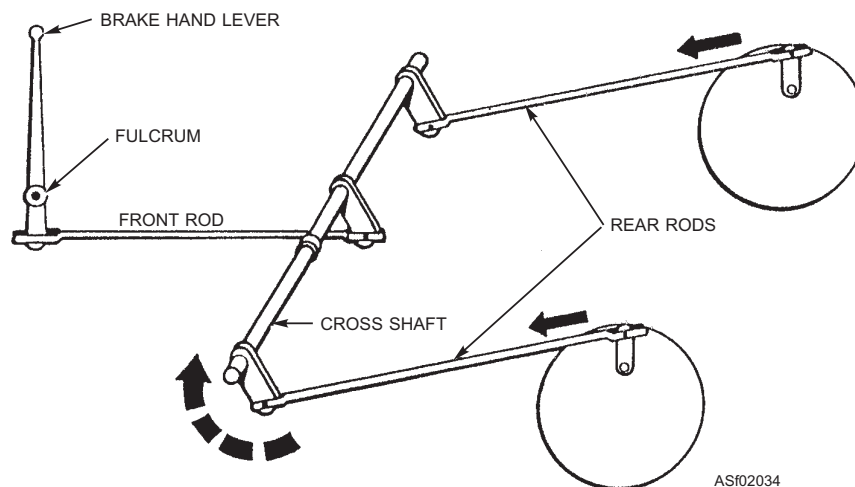

Figure 2-34.—Mechanical brake system—rods and shaft.

system should be inspected for signs of rust and corrosion. Maintenance includes replacement of defective parts, servicing with required lubricants, securing loose clamps and fittings, and straightening bent rods and shafts.

Upon replacement of any component, the brakes require adjustment to ensure both brakes are applied equally, that they hold the unit in place when the brakes are applied, and that they release fully when the brake level is in the released position.

Hydraulic Brake Systems

A hydraulic brake system is primarily a liquid connection or coupling between the brake pedal and the individual brake assemblies.

APPLICATION.—The effectiveness and reliability of hydraulic brake systems have been proven through their extensive use on automobiles for over 50 years. As a result, hydraulic systems are the most common systems used for the operation of the wheel brakes on powered support equipment. The hydraulic brake systems on some late model equipment are provided with a vacuum or air booster. The latest hydraulic brake systems used on support equipment tractors are true high-pressure hydraulic systems. These systems are powered by engine-driven hydraulic pumps.

COMPONENTS AND OPERATION.—Figure 2-35 shows a typical arrangement of a hydraulic brake system. The system consists of a master cylinder connected by tubing and flexible hose to the wheel cylinders. The master cylinder serves as a fluid reservoir, the system pump, and the control valve. The

wheel cylinders are the actuators. (An actuator is a device that transforms fluid pressure into mechanical force to move a mechanism.)

A nonpetroleum-based fluid is normally used in the brake systems of support equipment. The applicable technical manual should be consulted to ensure that the correct brake fluid is used.

Figure 2-36 shows the operation of a hydraulic brake system. Depressing the brake pedal moves the piston within the master cylinder, thus developing fluid pressure. This buildup of pressure forces fluid from the master cylinder into the fluid lines and the wheel cylinders.

Like all liquids, brake fluid for all practical purposes is noncompressible. Therefore, the pressure originated in the master cylinder is transmitted equally to the wheel cylinders. This pressure, applied at the wheel cylinders, causes the pistons to move outward.

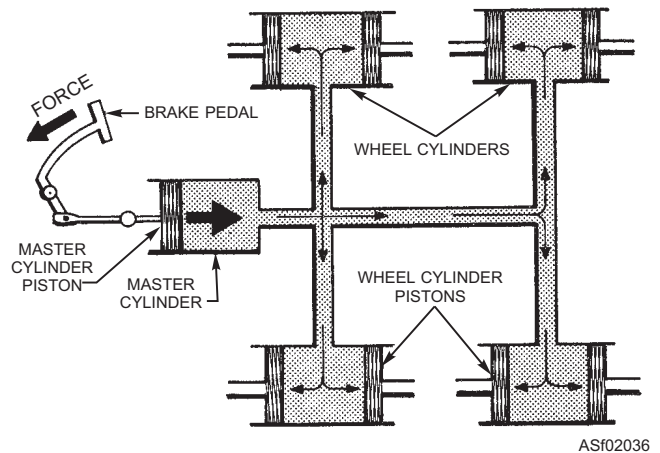

Figure 2-36.—Operation of hydraulic brake system.

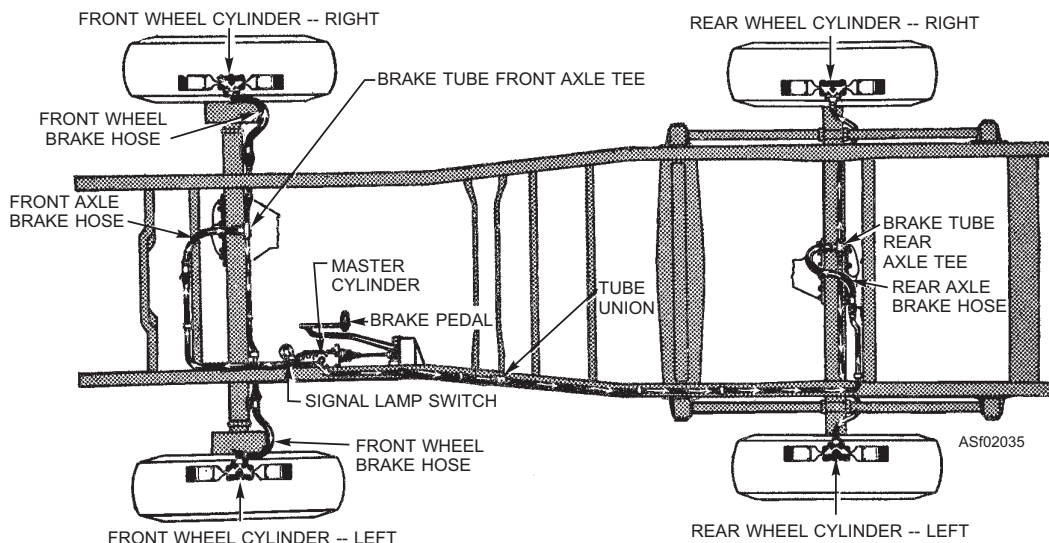

Figure 2-35.—Typical hydraulic brake system.

This pressure overcomes the tension of the retracting springs and forces the shoes against the drums. As the pressure on the foot pedal is increased, greater pressure is built up within the wheel cylinders and, consequently, greater force is exerted against the shoes.

When the pressure on the pedal is released, the brake shoe retracting springs return the brake shoes to their normal or released position. The return movement of the brake shoes, in turn, causes movement of the wheel cylinder pistons toward their released position since the force from the master cylinder is removed. The displaced fluid returns to the reservoir.

Master Cylinder.—A cutaway view of a typical master cylinder is shown in figure 2-37. The unit consists basically of an iron casting that contains a reservoir for the fluid and a machine-finished precision cylinder that houses the piston, return spring, and two-way valve assembly.

There are two ports leading from the reservoir (supply tank) to the cylinder—the breather port and the compensating port. Both ports serve to furnish fluid to the cylinder for the braking stroke. In addition, the breather port allows the fluid on the rod side of the piston to escape to the reservoir during the release stroke. This prevents a fluid lock when the brakes are released. The compensating port allows fluid to flow to and from the reservoir to allow for thermal expansion and contraction. Thus, a constant volume is maintained in the system at all times.

The reservoir is sealed at the top with a combination filler and breather cap, which permits atmospheric pressure on the fluid at all times.

The piston is a spool-like member with a rubber or leather cup seal at either end. These seals are referred to as the primary and secondary cups. The primary cup is held against the piston by the return spring and acts against the brake fluid during the braking stroke. The secondary cup is located at the other end of the piston and prevents external leakage of the brake fluid.

An explanation of the two-way valve can be made with reference to figure 2-38. As pressure is applied to the foot pedal and the piston is forced into the cylinder, the fluid pressure is applied to the inner and outer segments of the two-way valve. The spring, acting against the inner segment, is comparatively light. As the fluid pressure opens this valve, additional fluid enters the hydraulic lines, applying pressure to the pistons in the wheel cylinders.

As the brake pedal is released, fluid pressure in the wheel cylinders decreases. The brake shoe retracting springs, acting against the wheel cylinder pistons, cause a slight back pressure in the fluid lines. This pressure overcomes the tension of the return spring and forces the entire two-way valve assembly off its seat. This allows some of the fluid from the lines to enter the reservoir.

When the pressure in the lines decreases to approximately 6 to 16 psi, the return spring closes the valve unit against its seat. As a result the system remains under a small pressure. This pressure does not cause the shoes to drag, but it does assure a positive

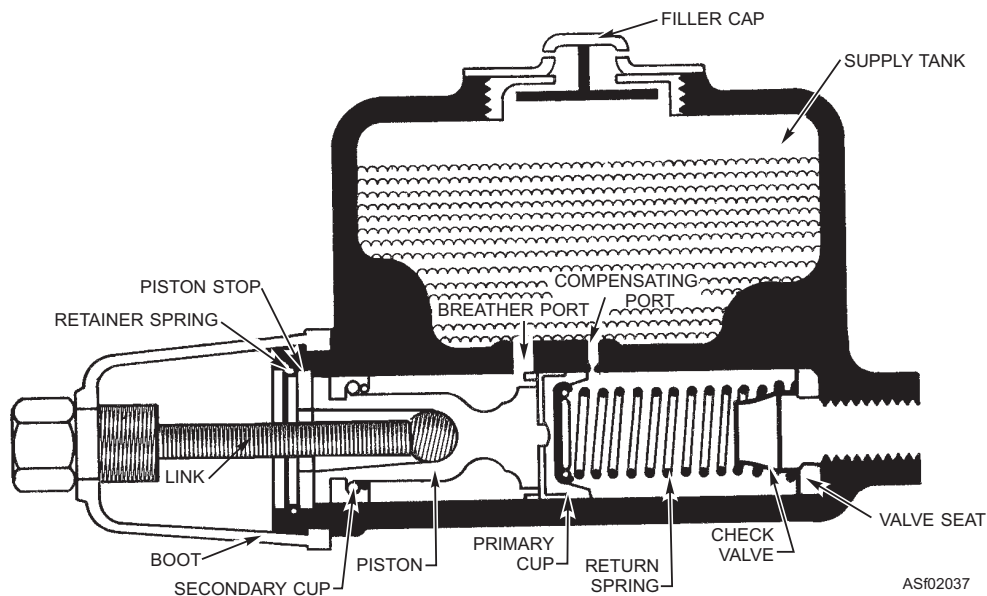

Figure 2-37.—Hydraulic brake master cylinder.

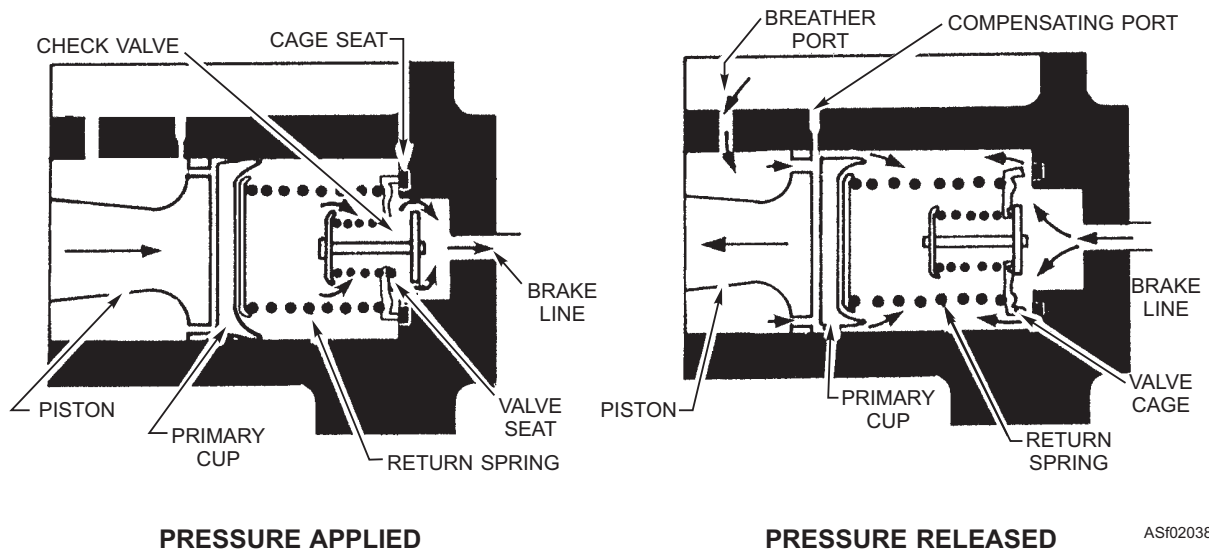

Figure 2-38.—Hydraulic brake master cylinder—operation of two-way valve.

seal at the wheel cylinder cup packing and prevents air from entering the system.

Wheel Cylinder.—The wheel cylinder may be of almost any design or exterior shape to suit the need, but all wheel cylinders work on the same basic principle and fulfill the requirements of moving the brake shoes into contact with the drum. There are two basic designs—a single-piston type and a double-piston type, sometimes called uniservo and duoservo cylinders, respectively. Different combinations of these two types of cylinders are used on different models of equipment.

Figure 2-39 illustrates a double-piston wheel cylinder. The single-piston is similar, only smaller because it has only one piston. This unit, regardless of whether single- or double-piston type, changes the applied fluid pressure into mechanical force to move the brake shoes. The wheel cylinder housing, made from a casting, is bolted to the brake backing plate.

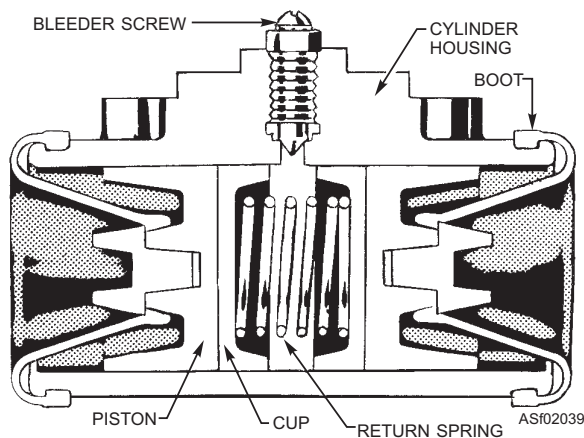

Figure 2-39.—Hydraulic brake wheel cylinder.

The two pistons in the cylinder move in opposite directions under hydraulic pressure. Through a short stem, the pistons push the shoes against the drum. These stems are connected directly to the shoes.

Rubber cup seals fit tightly in the cylinder bore against each piston to prevent the escape of fluid. Between the cups is a light spring to keep the cups in position against the pistons. The open ends of the cylinder are fitted with rubber boots to keep out foreign matter.

Brake fluid enters the cylinder from the brake line connection between the pistons. A bleeder port and valve are located at the top of the cylinder between the pistons. This provides a means for releasing air from the system.

Various applications of wheel cylinders are used in support equipment, depending upon the manufacturer's design. Some may have one single-piston cylinder or a dual-piston cylinder per wheel, each operating two shoes. Others may use a combination of one single and one dual piston or two dual pistons per wheel. When a dual system is used, each cylinder is mounted diametrically opposite the other, and each operates one end of two shoes.

INSPECTION AND MAINTENANCE.—Hydraulic brake systems must be inspected at specified intervals. A visual inspection includes checking the fluid level in the master cylinder reservoir, the security of mounting bolts and clamps, the condition of tubing and hoses, and the entire system for leaks. When the wheels and drums are removed for inspection of the brake assemblies, the wheel cylinder should be inspected for leaks. The boots may be pulled

from around the ends of the cylinder to check for leakage between the pistons and the cylinder wall.

An operational inspection of a hydraulic brake system may be accomplished during the road test. However, several checks may be made by operating the brake pedal while the vehicle is parked.

If the brake pedal bottoms when pushed down, a further check must be made of the system. This condition may be caused by worn brake linings, but more often by a defective hydraulic system. Insufficient fluid in the reservoir is a prime cause of this problem. If the fluid is low, the reservoir should be checked for external leaks.

Internal leakage from the lines through the master cylinder may also cause the pedal to bottom. Air in the hydraulic system should be suspected when the operation of the pedal is soft or spongy. The air must be removed to obtain a solid pedal. This process is called bleeding.

The maintenance of hydraulic brake systems consists of correcting the problems found during scheduled inspections and those that occur during normal operations. This includes servicing the system, repairing and replacing tubing and flexible hose, repairing the master cylinder and wheel cylinders, and bleeding the system.

Servicing.—As applied to hydraulic brake systems, servicing consists of checking the fluid level and adding necessary fluid to the master cylinder reservoir. When adding hydraulic fluid, be sure it is the kind recommended by the manufacturer. Some manufacturers use natural rubber seals in the operating systems, and others use synthetic rubber or other materials. Unless the recommended brake fluid is used, the seals deteriorate quickly, causing possible failure of the brake system.

Dirt and other foreign matter that accumulates around the filler opening can also affect brake operation. Even a small particle of dirt may find its way into the operating mechanism and close a vent or prevent a valve from sealing properly. All dirt and foreign matter must be removed before removing the filler cap. The fluid level should be approximately 1/4 to 1/2 inch from the filler opening. This distance is usually specified in the applicable service technical manual. This space compensates for thermal expansion of the brake fluid.

Master Cylinder Repair.—When the master cylinder requires repair, it must be removed from the

vehicle. If a stoplight switch is mounted on the cylinder, the wires must be disconnected first. Next, the hydraulic line and the pedal linkage are disconnected from the cylinder. Then, loosen the hold-down bolts and remove the cylinder. The exterior surface of the cylinder should be thoroughly cleaned before disassembly. Figure 2-37 identifies the various components and parts of the master cylinder.

After the exterior surface of the cylinder is cleaned, remove the filler cap of the reservoir and pour out and discard the fluid. Be sure to follow the proper procedure for disposal of the fluid. Clamp the master cylinder, boot upward, in a vise, and then remove the boot and pedal rod. Next, remove the spring retainer (snap ring). With this removed, the piston stop (a thick steel washer) is free to be removed with the piston. Remove the master cylinder from the vise and up-end the cylinder to allow the piston, spring, and valve assembly to slide out. The secondary cup, primary cup, piston spring, and valve assembly should all be replaced with new parts. These items are usually available in a repair kit.

After the parts are removed, the cylinder walls should be cleaned and inspected. If there are deep pits or scratches in the bore, the master cylinder should be replaced. The cylinder bore may be honed with a suitable stone to remove rust, scores, and shallow pits and scratches. After honing a cylinder, be sure that all abrasive dust is removed; then, lubricate the bore with new, clean brake fluid.

Assemble the parts into the cylinder in the logical order. First, install the valve assembly on the end of the piston return spring. Check again to ensure that the bore of the cylinder is clean and lubricated with clean fluid. Lubricate the new primary and secondary cups and piston. Guide the lips of the primary cup into the bore and use the piston to force the cup into the cylinder.

As the secondary cup is installed, be sure that the lips do not fold over when they contact the bore. Then, place the piston stop on the piston, and with a drift punch inserted in the hole at the back of the piston, force the piston into place. Hold the piston in place and install the spring retainer. Replace the pedal rod and a new boot. Install the filler cap only after ensuring that the vent hole is open.

Reinstall the master cylinder on the vehicle, reconnecting the brake line and the wire to the stoplight switch. Then connect the pedal rod to the brake pedal. The applicable technical manual should

be consulted for adjustment procedures for the pedal linkage. The master cylinder must be serviced and the system bled before the brakes are ready for service. However, before this is accomplished, all necessary repairs should be made to the wheel cylinders.

Wheel Cylinder Repair.—Wheel cylinders are rebuilt in much the same manner as a master cylinder. To do this, it is seldom necessary to remove the cylinder assembly from the brake backing plate. However, before the cylinder can be repaired, the brake assemblies must be removed.

To disassemble a wheel cylinder with two pistons (fig. 2-39), pull the boots from the cylinder and push the pistons, cups, and spring out of the cylinder.

After the parts are removed, clean the cylinder wall and check for pits and accumulation of rust. A small quantity of pits or rust at the exact center of the cylinder should not affect the operation of the wheel cylinder. If the rust or pits are just inside the outermost polished areas of the cylinder bore, they must be removed by honing. Cylinders containing deep pits or scratches must be replaced.

After honing a cylinder, remove all the abrasive dust and lubricate the cylinder walls with clean, new hydraulic fluid. The pistons are usually made of aluminum, and unless badly scored, they may be reused indefinitely. However, they should not be sanded—only cleaned with an approved solvent or clean, hydraulic brake fluid.

After the cylinder bore is satisfactorily cleaned and lubricated, lubricate the cup seals. Insert a cup into the end of a cylinder. Do not push the cup through the bore. As soon as the lips of the cup are in the bore, use the piston to move the cup into place.

Installing the other cup and piston may be more difficult, since the cup retaining spring will push against the cup and piston already installed. With one hand, hold the one piston from pushing out, and with the other hand, install the spring, cup, and piston. Then, install the boots and brake shoe links, rods, or slugs. Install a wheel cylinder clamp or use a cord or wire to tie a loop around the cylinder to hold the components in the cylinder until the brake shoes are installed.

Bleeding Hydraulic Brake Systems.—During repair of the master brake cylinder or wheel cylinders, or anytime a brake line is disconnected, air will enter the hydraulic brake system. Also, when the fluid level in the reservoir is allowed to become too low, air will enter the brake lines.

Most hydraulic systems are equipped with return lines between the actuating units and the reservoir. The fluid circulates from the reservoir, through the supply lines, through the actuating units, and back to the reservoir. This allows any air in the system to escape through the reservoir vent during circulations.

Brake hydraulic systems, however, are not equipped with return lines; therefore, there is no means for the air to escape. Air in the system will cause the action of the brake pedal to feel soft and spongy because air is compressible. The hydraulic brake system must be bled to expel this air.

There are two common methods of bleeding a hydraulic brake system—the pressure method and the manual method. The pressure method employs a brake bleeder tank, which delivers fluid under pressure to the master cylinder (fig. 2-40).

Before pressurizing the bleeder tank for use, ensure that the tank has an adequate supply of the required type of brake fluid and that the valve on the discharge line is closed.

Manufacturers usually recommend that the master cylinder reservoir be filled with hydraulic fluid before connecting the pressure tank. Make sure there is a tight seal between the adapter cap and the master cylinder filler port. Then, apply pressure to the master cylinder by opening the valve on the discharge line of the tank.

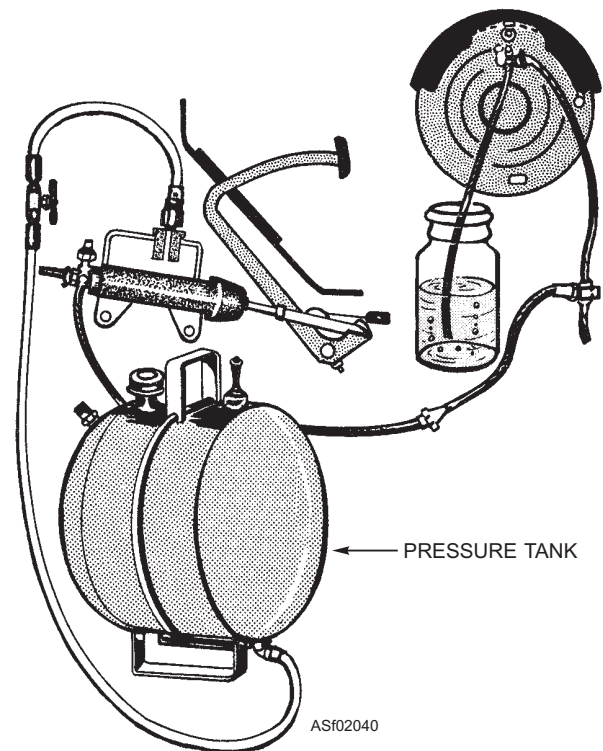

Figure 2-40.—Bleeding hydraulic system—pressure method.

Most authorities recommend that the system should be bled starting with the longest line and working successively to the shortest. Other authorities prefer the opposite method; that is, starting with the shortest line and finishing with the longest. So, you should always consult the technical manual for the unit you are servicing to see if there is a preferred method.

If you suspect that air is trapped in one specific brake line, bleed that line first. For example, assume that the right rear wheel cylinder of a vehicle has been disconnected for maintenance and repair. After the repair has been completed and the cylinder connected, this brake line should be bled first. In fact, it is possible that all of the air that entered the line while it was disconnected may be bled from the one bleeder valve.

If at all possible, use a length of flexible tubing and a clean glass bottle or jar to trap the brake fluid expelled from the wheel cylinder bleeder valve. Before attaching the tube, be sure to clean the bleeder valve end.

To bleed the line, first loosen the bleeder valve screw. This allows fluid to flow into the jar. Keep the end of the tube submerged in the fluid. By observing the flow from the tube, you will notice air bubbles as they appear. When the air bubbles stop, all the air has been expelled from that section of line and the wheel cylinder. Then, tighten the bleeder valve screw. Repeat this procedure with each bleeder valve. The use of the

tube and jar is recommended regardless of the method used to force fluid through the lines.

You can use a manual method that requires two persons. One person operates the brake pedal, pumping until the pedal action is hard—hydraulic pressure in the system. The other person opens the bleeder valve screw, allowing the air and fluid to escape as the brake pedal is still forced downward. As soon as the brake pedal nears bottom, the operator signals the other person so that person can close the bleeder valve. As soon as the valve is closed, the brake line pressure is again pumped up and the bleeder valve opened, repeating the process until the air is expelled.

When bleeding a hydraulic brake system that consists of two wheel cylinders, an upper and a lower on each wheel, the operation is slightly different. In that case, bleed the upper cylinder at each wheel first, and then bleed the lower cylinder.

High-Pressure Hydraulic Brake Systems

The latest type of hydraulic brake system is the style used on the aircraft tow tractor, Model A/S32A-37 (fig. 2-41). This system has a brake pedal (called a brake actuator in this equipment), but not a master cylinder. In place of the master cylinder, there is a spool valve in the actuator that controls the flow of hydraulic fluid to apply pressure on the disc brakes.

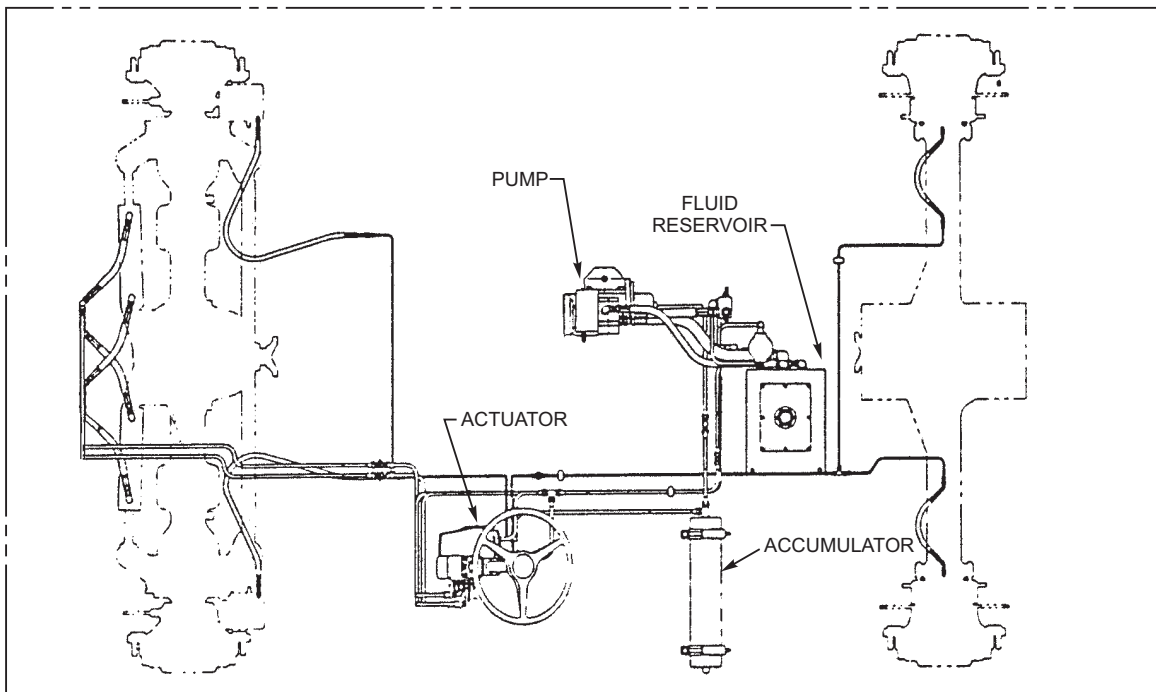

ASf02041

Figure 2-41.—Hydraulic system of the A/S32A-37 tow tractor.

When the brake is not pressured, excess hydraulic fluid is returned to the hydraulic reservoir.

The major difference in this system is that it has an open hydraulic system pressurized to 2200 psi with a 600 pound precharge in the accumulator to provide braking power even when the engine is not running. (Good for a limited number of uses.) The rest of the brake components are similar in appearance and operation to those of any disc brake system.

Power Brake Systems

The brake system most commonly used on powered support equipment is the hydraulically operated system. However, the increase in size and weight of aircraft has required heavier and more powerful support equipment, especially the aircraft-towing tractors. With this increase in vehicle power and weight, it is necessary to have a brake system that is more effective and less strenuous for the operator. It was almost impossible for the operator to apply sufficient braking action to control a heavy, yet comparatively small, vehicle. To compensate for this, some hydraulic brake systems are equipped with a form of power system to assist the force of the operator's foot in applying the brakes.

Power brake systems use the principle of the hydraulic brake to operate the wheel brake cylinders and produce braking action. In addition, these systems use the energy of air pressure, either to apply the necessary pressure to the hydraulic fluid or to assist in this application. Atmospheric pressure provides this energy in some power systems, while a compressor is required in others. Many of the Navy's aircraft-towing tractors are equipped with some type of power brake system. Some are equipped with a form of vacuum-boost system, while others use an air-over-hydraulic system.

Vacuum Systems

Air has weight (atmospheric pressure), and this weight results in a pressure of approximately 14.7 psi at sea level. It is this air pressure that is used in the operation of vacuum brake systems.

It is impossible to create a perfect vacuum, but by pumping air from a container, it is possible to obtain several pounds per square inch difference in pressure between the outside and the inside of the container. If the container were suddenly opened, outside air (atmospheric pressure) would rush into the container to equalize the pressure. It is upon this principle that the power cylinder of a vacuum brake system operates.

There are many varieties of vacuum-powered brake systems, and it is impossible to cover them all within the scope of this course. However, the system most commonly used on support equipment is called Hydrovac.

The Hydrovac combines into one assembly a hydraulically actuated control valve, a tandem piston vacuum power cylinder, and a hydraulic slave cylinder (fig. 2-42). The vacuum power brake cylinder is connected hydraulically to both the master cylinder and the wheel cylinders.

The vacuum source for this system, as for all vacuum brake systems, is the intake manifold of the engine. Reciprocating engines, particularly gasoline engines, generate a substantial vacuum in this area except when running at full power. A check valve maintains a vacuum within the system, even after the engine is stopped, by closing the intake manifold when the pressure in the manifold rises above the vacuum pressure within the system. A vacuum reservoir is usually required so that a substantial source of vacuum is available. Once air is pumped out of the vacuum reservoir through the intake manifold, the resulting

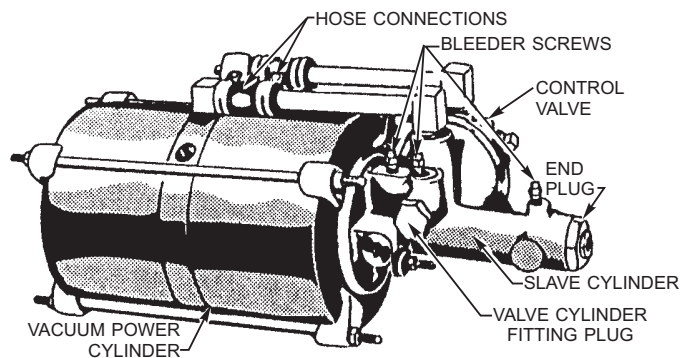

ASI02042

Figure 2-42.—Hydrovac vacuum power brake cylinder.

vacuum is diminished only by operating the power cylinder.

The vacuum power cylinder is divided into four compartments by the front and rear pistons and the center plate (fig. 2-43). The vacuum source is directly connected to the compartment between the center plate and rear piston. The vacuum is connected from this compartment, by means of the vacuum line, to the relay or control valve. From the control valve, the vacuum is connected to the front compartment by a passage in the valve body.

In the released position, the control valve diaphragm plate and vacuum valve seat is held down by the valve spring. This keeps the vacuum valve open and the atmospheric valve closed. In this position, the vacuum is connected through the vacuum valve and the atmospheric control line to the compartment between the center plate and front piston and, through the parts in the hollow piston rod, to the rear compartment. Therefore, vacuum is present in all compartments in the released position, and both pistons remain inoperative.

The piston return spring holds the pistons in the OFF position. The push rod, in the released position, maintains the bypass (check) valve off its seat, permitting a direct hydraulic connection from the master cylinder, through the hydraulic slave cylinder, to the wheel cylinders.

With this construction, foot pedal pressure can be applied to the wheel cylinders for braking action should vacuum or Hydrovac failure make the power cylinder inoperative. The relay valve diaphragm has vacuum on both sides, and is held in the OFF position by the valve spring. When the vacuum in the Hydrovac is the same as, or greater than, the source vacuum, the poppet valve in the vacuum check valve rests on its seat and, in the event of engine failure or rapid acceleration, traps the vacuum in the Hydrovac system in readiness for brake application.

As the foot pedal is depressed, fluid is forced from the master cylinder through the open bypass (check) valve to the slave cylinder and on to the wheel cylinders (fig. 2-44). The fluid is also forced through the drilled bypass passage to the relay valve hydraulic piston, which is forced outward against the pressure of the valve spring. This gradually forces the diaphragm plate and vacuum valve seat toward the brakes-applied position.

The movement of the diaphragm first closes the vacuum valve against its seat, sealing off the vacuum from the atmospheric control line. After the vacuum valve is seated, further motion of the diaphragm causes the atmospheric valve to leave its seat. This permits air from the air cleaner to enter the atmospheric control line, and then to the compartment between the center plate and the front piston. It then flows through the hollow piston rod to the rear compartment. With the

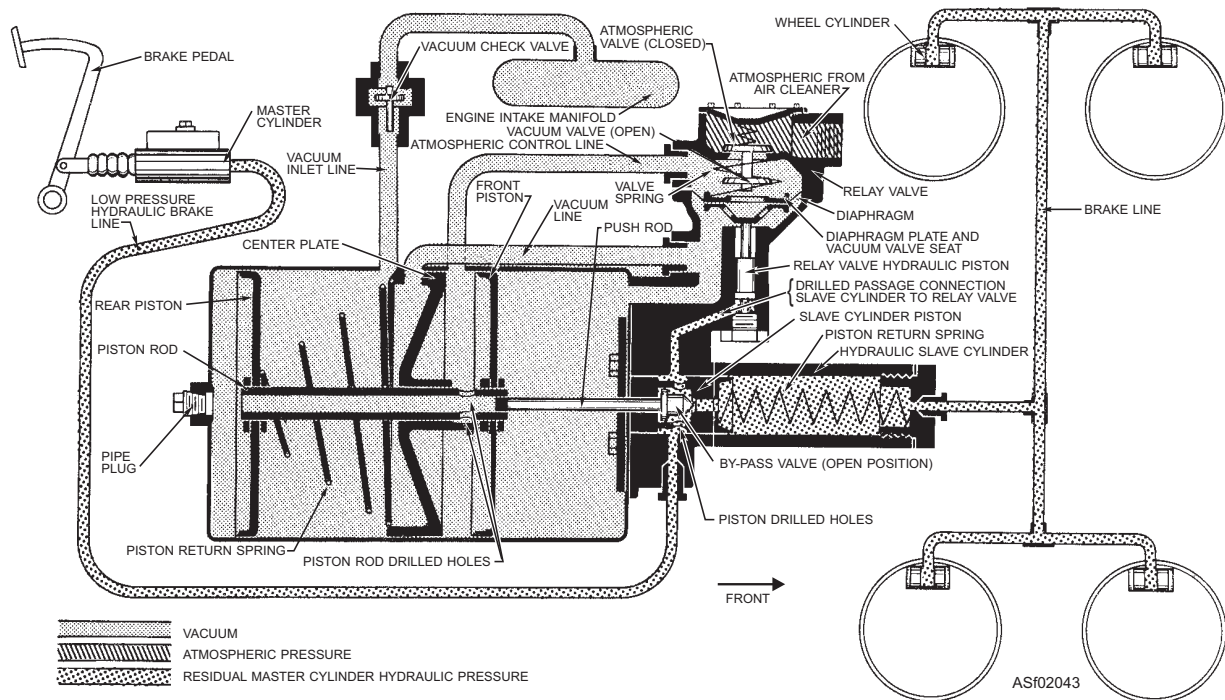

Figure 2-43.—Hydrovac operation—released position.

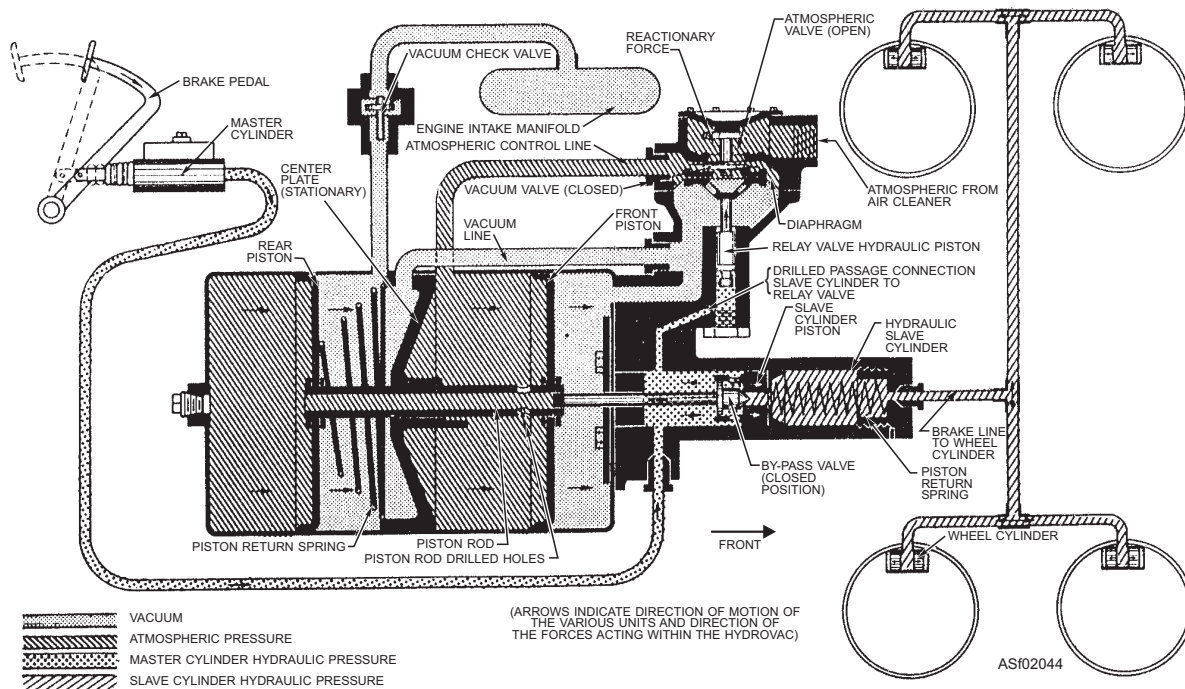

Figure 2-44.—Hydrovac operation—applied position.

vacuum still present on the front side of both pistons and atmospheric pressure on the rear sides of both pistons, the pistons are forced toward the slave cylinder.

Movement of the pistons and push rod toward the slave cylinder closes the bypass (check) valve, and then causes the slave-cylinder piston to move outward. This forces fluid under pressure into the wheel cylinders to apply the brakes. The foot pedal pressure, acting through the master cylinder, also acts against the slave cylinder piston, assisting the vacuum pistons and push rods. The pressure at the wheel cylinders (that is, the total braking effort) is the sum of the output of the vacuum pistons in the Hydrovac and the foot pedal pressure at the master cylinder.

Release of foot pedal pressure removes the fluid pressure from below the relay valve hydraulic piston. This allows the valve spring in the relay or control valve to return the atmospheric and vacuum valves to the released position. The atmosphere is exhausted from the rear sides of both pistons, making them inoperative and allowing the piston return spring to move the pistons to the released position.

When the foot pedal movement stops at some intermediate point between the released and fully applied position, the pistons will move slightly toward the applied position. This reduces the fluid pressure under the relay valve hydraulic piston the necessary amount to allow the diaphragm to drop and close both

the atmospheric and vacuum valves in the control valve. Thereafter, the slightest foot pedal movement, either toward the released or applied position, will result in opening either the vacuum or atmospheric valve, and will partially release or further apply the brakes.

With the exception of the vacuum system and particularly the power cylinder, the inspection and maintenance procedures for vacuum brake systems are similar to those required for hydraulic brake systems.

To check the vacuum brake system, first shut off the engine and apply the brakes several times to bleed all vacuum from the system. This may require as many as 20 or 30 applications on systems equipped with vacuum reservoirs. Spongy or soft action of the brake pedal indicates air in the hydraulic system. If this occurs, the system must be bled.

With the pedal held at the normal braking pressure, start the engine. If the pedal lowers toward the floorboard when the engine starts, the vacuum system is operating properly. If the pedal fails to move, the vacuum system is at fault.

Figure 2-45 shows a type of air-over-hydraulic brake system that is used on some of the newer tow tractors. The air control valve controls the flow of compressed air to an air chamber in the master cylinder. The air control valve is mechanically linked to the brake pedal.

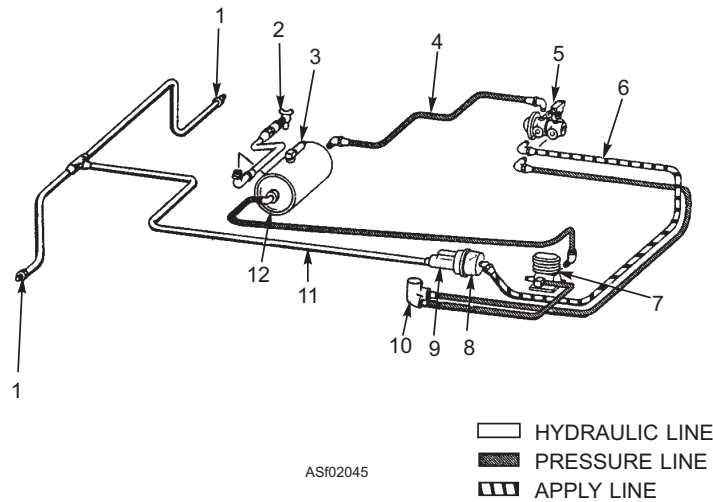

ASf02045

- | | | |
|------------------------------|---------------------|--------------------------|
| 1. Wheel cylinder connectors | 5. Control valve | 9. Master brake cylinder |
| 2. Tank drain valve | 6. Control air line | 10. System governor |
| 3. System safety valve | 7. Air compressor | 11. Hydraulic line |
| 4. Compressed air line | 8. Air chamber | 12. Air reservoir |

Figure 2-45.—Air-over-hydraulic brake system.

Brake application is relative to the pressure applied by the operator on the brake pedal. The brakes of the vehicle may be partially released at any time by slightly relieving pressure on the pedal or entirely released by removing all pressure from the pedal. One of the ports of the air control valve is an exhaust port, which releases air from the air chamber of the master cylinder during the release action.

The master brake cylinder assembly is the point in this system where the pneumatic system and hydraulic system join. Figure 2-46 shows a partial cutaway view of the assembly. Only the air chamber is shown cut away because the design and operation of the master cylinder part of the assembly are similar to any other hydraulic master brake cylinder.

The piston and piston rod of the air chamber are connected to the push rod of the master cylinder. When the brakes are applied, the air control valve allows air under pressure to enter the air pressure port of the air chamber. This pressure forces the diaphragm to move the piston and piston rod in the air chamber and compresses the return spring. This movement, in turn, moves the push rod and piston in the master cylinder, forcing fluid pressure to the wheel cylinders. When the brakes are released, the air control valve stops the flow of air to the air chamber and at the same time opens the exhaust port. This allows the air to flow out of the chamber, through the line, and out the exhaust port of the control valve. The return spring returns the piston and piston rod to the release position. This movement

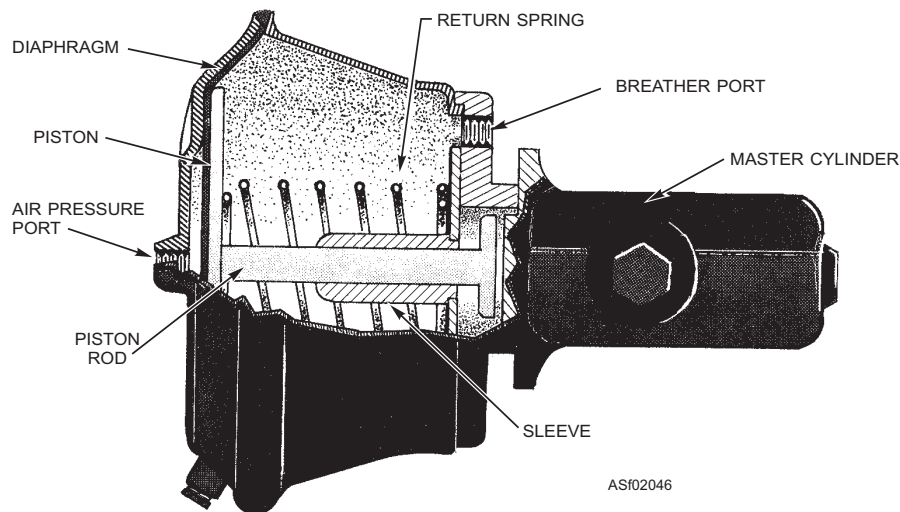

ASf02046

Figure 2-46.—Master cylinder assembly—air-over-hydraulic brake system.

releases the brakes through the action of the master cylinder.

The inspection and maintenance procedures described earlier for hydraulic and pneumatic brake systems apply as well to the hydraulic and pneumatic portions of the air-over-hydraulic system. You should consult the appropriate technical manual for required maintenance of the master cylinder assembly.

Q2-15. On a drum type brake system, which of the following malfunctions, if any, will occur if the anchor pin is too near the center of the drum?

1. The shoe will not firmly press against the drum when brakes are applied
2. The shoe will automatically lock when brakes are initially applied
3. The brake pedal will go to the floor when brakes are applied
4. None

Q2-16. A disc brake assembly consists of a metal disc and which of the following components?

1. A caliper
2. A wheel cylinder
3. An actuating cylinder
4. A brake drum

Q2-17. What is the main advantage of bonding a brake pad to the brake shoe?

1. Bonding reduces manufacturing costs
2. Bonding allows for the use of thicker pads to be used
3. Bonding reduces the amount of galvanic corrosion
4. Bonding allows the pad to be worn thin without scarring the drum

Q2-18. Brake linings that are riveted to the brake shoe should be replaced if worn to less than what percent of their original thickness?

1. 10 percent
2. 20 percent
3. 30 percent
4. 40 percent

Q2-19. What method of bleeding a brake system employs a bleeder tank?

1. The conventional method
2. The pressure method
3. The universal method
4. The manual method

POWER TRAINS

LEARNING OBJECTIVE: Identify the components of a basic power train.

Aviation support equipment that is powered and mobile must have a method of transferring the power from the engine to the wheels. This is the basic power train, which consists of the transmission, propeller shaft, universal joints, differential, and axles. Figure 2-47 shows one type of power train.

Consider the power train required in a four-wheel (rear) drive vehicle. In the process of transmitting power from the engine to the driving wheels, the power train provides the following:

- A means of engaging the engine to the drive wheel
- Several different gear ratios between the engine and the drive wheels

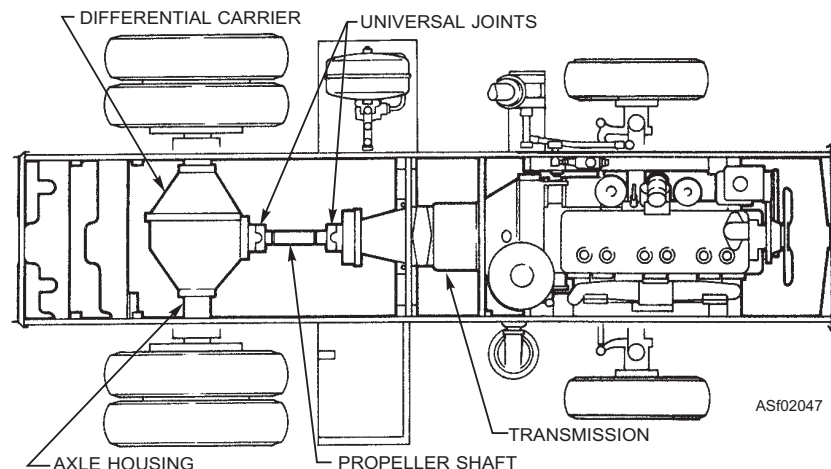

Figure 2-47.—Power train.

- A means of changing the direction of rotation of the drive wheels (forward and reverse)
- A means of permitting one drive wheel to turn at a different speed than the other

In addition to the basic components of a power train, one or more of the following additional components may also be part of a drive train: fluid couplings, torque converters, transfer cases, and auxiliary transmissions.

NOTE: *Basic Machines*, NAVEDTRA 14037, has an entire chapter devoted to the power train, in which most of the components are described and illustrated. As a result, these components are described only briefly in this discussion. Emphasis is on those component that are not adequately covered in *Basic Machines* and some of the applications and different arrangements of power trains in support equipment. Therefore, for a better understanding of the functions and operations of the components of the power train, the appropriate chapter in *Basic Machines* should be studied in conjunction with this text.

Q2-20. What are the components of a basic power train?

1. *Transmission, propeller shaft, universal joints, differential, and axles*
2. *Transmission, propeller shaft, universal joints, axles, and torque converters*
3. *Torque converter, transfer case, fluid couplings, and auxiliary transmission*
4. *Torque converter, axles, transmission, fluid couplings, and transfer case*

TRANSMISSIONS

LEARNING OBJECTIVES: Identify the components of support equipment transmissions. Identify procedures for inspecting, checking, testing, and adjusting support equipment transmissions. Identify procedures for troubleshooting support equipment. Identify procedures for repairing, removing, and replacing support equipment transmissions.

If the power requirements between the engine and the drive wheels were relatively constant, a power train consisting of a drive shaft and some type of clutch to obtain gradual application of the load on the engine would be sufficient. Speed could be regulated by the engine throttle. However, this is not the case with

self-propelled automotive vehicles. Whether the vehicle is the family automobile, an aircraft tow tractor, a fire truck, or a weapons loader, a great deal more power is required to start the vehicle in motion than to keep it in motion. Also, power requirements vary with the load on the vehicle. In addition, both forward and reverse movements are required. Therefore, some type of speed and power changing device is required in the power train. This device is the transmission.

In a discussion of the transfer of power from the engine to the drive wheels, we must consider the effects of TORQUE and SPEED. Torque is a twisting force that tends to produce rotation or torsion. The engine power applies this twisting force to the shafts and other rotating members of the power train.

Consider a small gear (10 teeth) keyed to a shaft (driving), extending from the crankshaft, and meshed with a larger gear (20 teeth), which is keyed to a second shaft (driven). The driving shaft is parallel to the driven shaft, and power from the engine applies torque to the driving shaft. As the driving shaft turns, the teeth of the smaller gear apply torque force to the teeth of the larger gear, which, in turn, apply torque to the driven shaft. Since the distance from the center to the rim of the larger gear is greater than that of the smaller gear, the twisting force or torque applied on the driven shaft is greater than the torque of the driving shaft. Therefore, the torque applied by the engine has been increased.

In the process of increasing the torque, something must be lost or decreased. It requires two revolutions of the small gear (10 teeth) for one revolution of the large gear (20 teeth), which is a gear ratio of 2 to 1. Therefore, as the torque increases, speed decreases. By altering the sizes of the gears on either or both shafts, almost any combination of speed and torque can be obtained, within the capabilities of the engine. Basically, this is what a transmission accomplishes by means of gears or other methods.

NOTE: *Basic Machines*, NAVEDTRA 14037, contains detailed information about the types of gears and the manner in which gears may be arranged to change the speed, torque, or direction of rotation of a shaft.

There are many different types of transmissions; however, most can be placed into one of two classes—standard and automatic. With a standard transmission, the operator must manually shift the transmission from one speed/torque ratio to another using a manually operated clutch. With an automatic

transmission, the operator selects neutral, reverse, or one of several ranges of forward speed. The transmission automatically shifts from one forward speed/torque ratio to another based on the rpm of the engine and the speed of the vehicle. The automatic transmission does not require a manually operated clutch. All support equipment used by the Navy have automatic transmissions.

Most of the fundamentals of hydraulics are put to work in one form or another in the automatic transmission. Automatic transmissions use such hydraulic devices as relief valves, shifter valves, pressure regulators, governors, and servo pistons. In most cases, the transmissions are used with fluid couplings or hydraulic torque converters.

FLUID COUPLINGS

A fluid coupling, sometimes called a “fluid clutch,” is precisely what its name implies. When it is placed between an engine at the power-input end and some other mechanism, such as a transmission at the output end, it couples the two hydraulically, and there is absolutely no mechanical connection between them. A simple sort of fluid coupling can be made with two electric fans, as shown in figure 2-48. If the fans are placed a few inches apart, facing each other, and one fan is plugged in so that it runs, the current of air from the running fan will cause the blades of the other fan to turn. In this case, the air takes the place of the fluid. Since the two fans are not enclosed or closely coupled, this sort of coupling is not very efficient.

To make a more efficient coupling, oil is used, and the two members (driving member and driven member) are mounted very close together and enclosed in a housing. In a fluid coupling, the driving member is called the PUMP and the driven member the TURBINE. This terminology is not universal. Some manufacturers call the pump the IMPELLER or

DRIVER, and the turbine may be called the RUNNER. Often the two members are called the FRONT TORUS and the REAR TORUS. (A torus is doughnut-shaped and turns on an axis.) You should become familiar with all these terms so that you can understand the manufacturers’ technical manuals. Note that in figure 2-49, the pump and turbine are torus-shaped with fins extending radially from its center.

The pump of the fluid coupling is connected to the engine and is rotated by the crankshaft. Usually, the pump is bolted directly to the flywheel.

The turbine is made exactly like the pump, but it is connected to the transmission input shaft. The two members of the coupling face each other within a housing that is filled with the driving fluid (generally oil).

When the pump goes into motion, oil is forced outward by centrifugal force around the entire circumference of the pump and hurled against the blades of the turbine. A continuous flow of oil against the turbine blades is necessary to transfer sufficient kinetic energy to keep a vehicle in motion.

The centrifugal force of the oil as it leaves the pump gives the oil the velocity it needs. The faster the pump operates, the more velocity the oil has when leaving the pump. The design of the coupling permits the oil to return to the pump as soon as it has delivered its energy to the turbine.

Where the vehicle has not started to move, the turbine is stationary. For instance, the engine may be rotating the pump at 900 rpm. The pump is consequently imparting energy to the fluid, which, in turn, imparts energy to the turbine. By the time the oil returns to the pump, the pump has moved some distance, making it impossible for the oil to re-enter the pump through the same set of vanes it left. Consider one drop of oil as it leaves the pump, goes through the

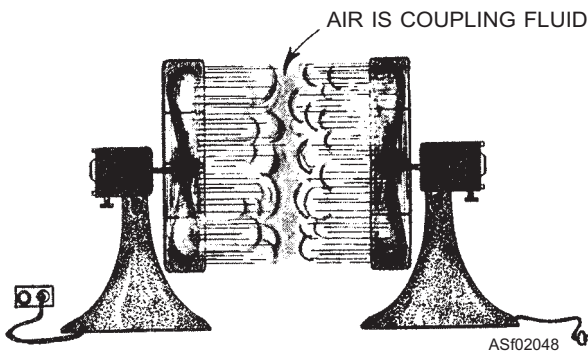

Figure 2-48.—Basic fluid coupling, using air in place of fluid.

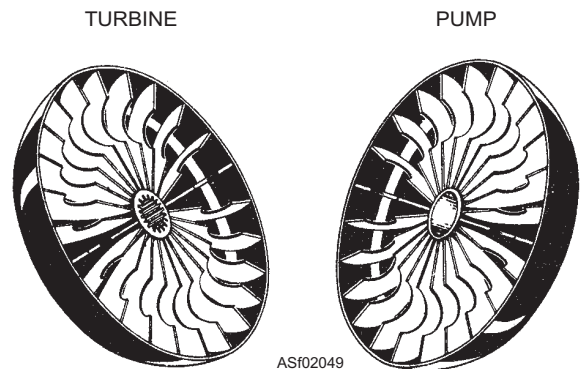

Figure 2-49.—Fluid coupling pump and turbine.

turbine, and back to the pump. The drop would follow a path that looks something like a string wound around a doughnut through the hole (fig. 2-50). This path of oil is called a vortex and is the path of the stream of oil that drives the turbine. There are as many vortex streams in a fluid coupling as there are vanes.

As the turbine begins to turn, the difference in speed between the pump and the turbine decreases. As the speed difference decreases, the coils of the vortex become closer together. A **LOW VORTEX** exists when the pump and turbine are traveling at nearly the same speed. A **HIGH VORTEX** exists when the pump and turbine speeds differ greatly.

The higher the vortex, the greater is the driving power of the oil. When the vortex is high, the oil tends to strike the fins on the turbine at nearly a right angle.

The degree of vortex is continually changing and is determined by the difference in speed between the members of the coupling.

A condition known as “zero vortex” or “fluid coupling stage” exists only when the two members of the fluid coupling are turning at exactly the same speed. When this happens the fluid coupling actually has no driving power. The pump, turbine, and the fluid within the coupling are all turning as one unit in a rotary motion.

The fluid coupling stage seldom exists because the turbine usually lags a little behind the pump when there is a load on the vehicle. The fluid coupling stage exists momentarily when the vehicle begins to coast or reduce speed. As soon as the engine slows down, the momentum of the vehicle causes the turbine to throw a vortex of oil at the pump, thus permitting the engine to help reduce the speed of the vehicle by creating a drag.

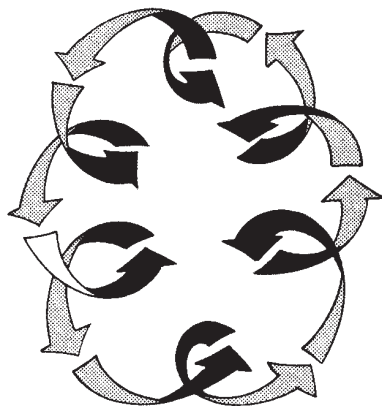

VORTEX FLOW IN A FLUID

ASF02050

Figure 2-50.—Schematic of vortex flow in a liquid.

With fluid couplings, shock loads can never be transmitted into the engine. Sudden gear-breaking jerks are impossible. If a vehicle is overloaded, the fluid coupling slips and never allows the engine to become overloaded. Thus, harmful low-speed lugging of the engine is impossible. Vibrations and irregularities of the engine can be harmful to the rest of the vehicle’s power train, but with fluid couplings, it is impossible for these engine irregularities to be transmitted to the power train.

Since a fluid coupling is nothing more than a sort of connecting link, it can deliver only the torque or “twist” delivered to it; it cannot increase torque or power. To get this added feature requires the use of a torque converter.

TORQUE CONVERTERS

At first glance, torque converters appear very similar to fluid couplings and, in fact, are similar in several ways. Both have a driving member and a driven member. Both transmit torque (or power) by passing oil from the vanes of the pump to the vanes of the turbine. However, the fluid coupling is essentially a special form of clutch that transmits torque at maximum efficiency when both members are turning at close to the same speed. When the pump turns appreciably faster than the turbine, the efficiency coupling of torque into the turbine is lowered.

Figure 2-51 shows a fluid coupling with the driving member (pump) turning much faster than the

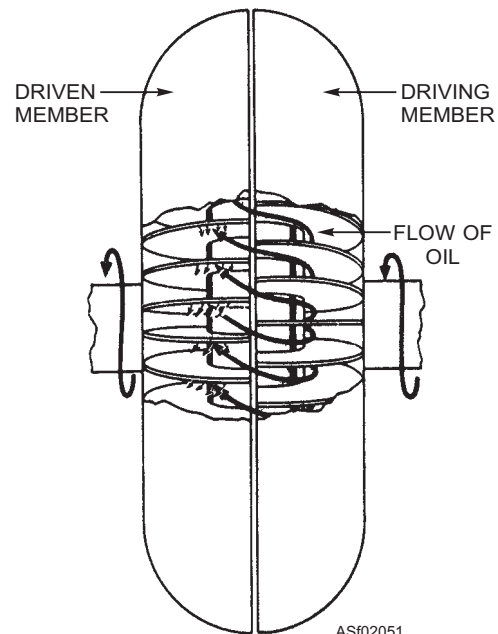

ASF02051

Figure 2-51.—Fluid coupling oil flow “bounce back” effect.

driven member (turbine). Notice that the vanes of the pump are radial to the shaft and set straight. The turbine vanes are exactly the same as those of the pump. Therefore, when the pump is turning much faster than the turbine, the oil is thrown onto the vanes of the turbine with considerable force, as shown by the heavy arrows. The oil strikes the vanes of the turbine and splashes, or bounces back, as shown by the smaller arrows.

The “bounce back” effect actually opposes the oil flow from the pump and causes inefficiency, or torque loss. Thus, when there is a big difference in driving and driven speeds, a good share of the driving torque is used in overcoming the bounce back effect. This bounce back effect becomes less and less as the speeds of the pump and turbine come closer together. At the fluid coupling stage, the bounce back effect is practically gone, resulting in a very good torque coupling between the pump and turbine.

The torque coupling, on the other hand, is greatly different in the torque converter. The torque converter is designed to prevent, or reduce to a minimum, the effects of oil bounce back. This is accomplished by the use of one or more members, in addition to the pump and turbine. The vanes of all the members are curved to either aid in the torque coupling from one member to another, or at least not to be a hindrance to this coupling. As a result of the torque converter design, there is no torque loss when there is a large speed difference between the pump and turbine. Quite the contrary—when there is a large speed difference, the torque is increased, or multiplied, in the torque converter.

The torque converter may be thought of as a special form of fluid coupling that acts, in a sense, like a gear transmission with a large number of gearshift positions. That is, it can transmit torque at a 1 to 1 ratio (direct drive); or under certain conditions, the converter can increase the torque so that more torque is delivered than is applied. However, just as in a standard transmission, if there is a torque increase there is a speed reduction.

The torque converter provides varying drive ratios between the pump and turbine, thereby providing varying amounts of torque increase. This is accomplished by the use of curved vanes in the pump and turbine and by the use of one or more extra members (elements). These additional members are placed between the driving and driven members. The vane curvature can be seen in the torque converter cutaway shown in figure 2-52. As in the fluid coupling,

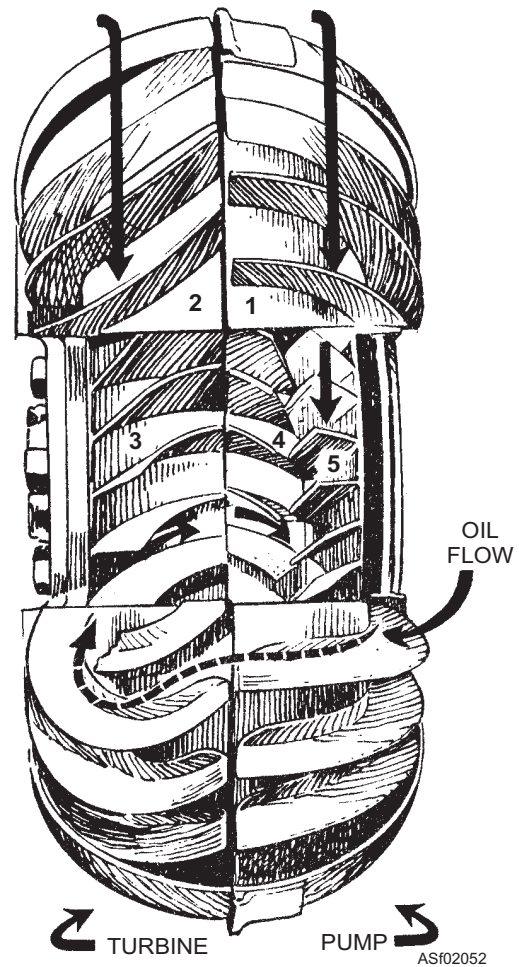

Figure 2-52.—Torque converter, multi-element.

the pump hurls the oil into the vanes of the turbine, but because of the curvature of the vanes, the change in the direction of the oil is gradual, thus reducing the effects of bounce back. As the oil passes through the turbine, its direction is changed by the curved vanes so that it leaves the trailing edges of the turbine vanes in a direction to oppose the pump direction. This, in effect, would be worse than the bounce back effect of the fluid coupling. However, the oil is again redirected before it reaches the pump by the addition of a third member, a STATOR. The stator is a curved vane that redirects the oil from the turbine into the pump in a way that aids rather than hinders its rotation. It is this aid caused by the stator that produces torque multiplication in the torque converter.

Torque converter stator operation and the ability of the torque converter to multiply torque may be better understood by studying figure 2-53. Figure 2-53 illustrates the effects of a jet of oil on a flat piece of metal and on a bucket attached to a wheel. The oil jet will impart a terrific force against the flat piece of metal, as shown in view A; however, notice the bounce

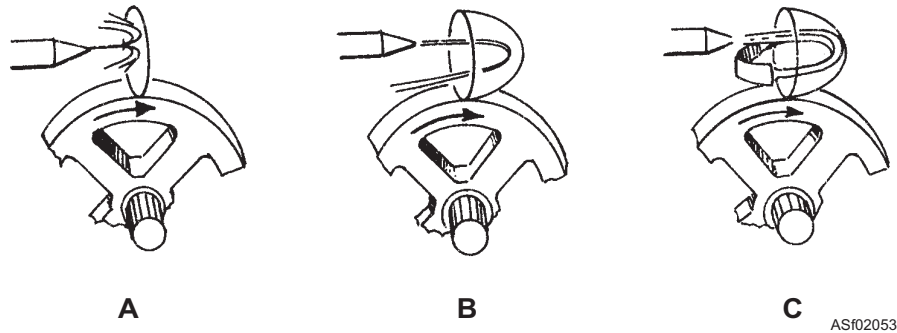

Figure 2-53.—Effects of oil jetstream on a flat surface and on a curved surface.

back of oil, which is wasted power. If the oil enters and leaves a curved bucket, as in view B, the push imparted to the bucket and wheel is small. However, if a curved vane is used to redirect the oil leaving the bucket back into the bucket as in view C, the torque is increased. Detail views B and C act like a torque converter with a pump, turbine, and stator.

Normally, a torque converter has at least three members. However, some have more than three members. Refer again to figure 2-52. This converter has five members, and each member is numbered in sequence as oil passes through it; thus, (1) is the primary pump, (2) is the turbine, (3) is the secondary stator, (4) is the primary stator, and (5) is the secondary pump. The five members are mounted on shafts and hubs in such a way that each one has some degree of independent rotation. The stator elements are mounted through overrunning clutches to a stationary hub shaft, while the secondary pump is mounted through an overrunning clutch to the pump shaft. If there is a secondary turbine element, it will be mounted on the turbine shaft.

When the vehicle is first started or is under heavy load (fig. 2-52), the primary pump (1) is turning at a relatively high speed while the turbine (2) is turning slowly. As shown by the oil flow arrow, the oil is passing from the primary pump (1) to and through the turbine (2). As the oil leaves the turbine (2), it flows into the stators (3 and 4). Notice that these stators change the direction of the oil flow to aid the primary pump (1). However, the secondary pump (5) is between the primary stator (4) and the primary pump (1). Note how the vanes of the secondary pump (5) oppose the oil flow from the stators to the primary pump (1).

The secondary pump (5) is not needed during heavy load, hard acceleration operation. To keep it from hindering the action of the torque converter at this time, the secondary pump is allowed to overrun, or spin faster than the primary pump. This moves it out of the path of the oil flow into the main pump. The secondary

pump is mounted on an overrunning clutch to make this possible. The overrunning clutch allows the secondary pump to spin faster than the primary pump when the oil is hitting the back faces of its vanes, but locks or “clutches” when the secondary pump tries to rotate more slowly than the primary pump. More information is given about overrunning clutches later in this section.

After start and during normal operation, turbine (2) picks up speed and thus approaches the speed of pump (1). Under these conditions the total oil mass between pump (1) and turbine (2) rotates (a low coil vortex condition as described earlier develops), and secondary pump (5) overruns.

During this time, the oil, as it leaves the trailing edges of the turbine, is not thrown back with as great a thrust against the vanes of stator (3). As a result, the rotating oil mass will cause stator (3) to begin to rotate (it is also mounted on an overrunning clutch). As stator (3) begins to rotate, the oil leaving the turbine vanes hits the back side of the stator vanes and overruns to move out of the oil flow path.

At the time this is happening, secondary pump (5) tends to slow down as the oil no longer strikes the back side of its vanes with any appreciable thrust. It “clutches” or locks and actually helps the primary pump impart some forward motion or driving force to the oil. Primary stator (4) remains stationary and changes the oil flow direction only slightly.

When the turbine and primary pump reach the “coupling stage”, the torque converter acts just like a fluid coupling. At this time, both stators (3) and (4) are freewheeling, or rotating with the mass of rotating oil. Neither is contributing anything to the converter operation.

The secondary pump, however, is locked to the primary pump, and thus helps impart the required driving force to the oil under light loads or high speeds.

The foregoing discussion of torque converters is general, and is adaptable to the operational understanding of any hydraulic torque converter. Actually, the changeover from stall speed to coupling speed in the converter, as outlined above, is not sudden but gradual and is determined by the power demands of the load and/or operator. When the vehicle begins to move, there is one power demand. Then, as the turbine speed begins to increase, the oil flow direction in the converter begins to shift. The shifting oil pattern effects the torque multiplication. This effectively reflects changing power demands, and is similar to a gear-type transmission with an infinite number of gear ratios.

The torque converter, like the fluid coupling, can be used as a coupling between the engine and a mechanical clutch. However, since the torque converter can effectively vary torque ratios, a transmission is not always required. There is no reverse or neutral on the torque converter; therefore, a transmission is normally used to meet the demands required of most moving vehicles. Some converters also incorporate a lockup clutch and a retarding device within the converter hydraulic system.

Converter Hydraulic System

The converter hydraulic (oil) system usually consists of a reservoir, a supply pump, a filter, and a cooler. When the converter is used in conjunction with an automatic transmission, the sump of the transmission is used as the reservoir, since the oil is circulated to the converter and other hydraulic units of the transmission by the supply pump.

The cooler, or heat exchanger, is used to dissipate the heat that is generated by the converter. The oil is constantly subjected to agitation and motion when the vehicle is operating, thus it becomes very hot. Some converters have fins on the pump housing similar to the fins on an air-cooled engine to dissipate the heat. Others use the circulating coolant of the vehicle's engine for cooling, while still others use a heat exchanger of the radiator type. A typical radiator-type heat exchanger is shown in figure 2-54. This type of cooler is mounted with the radiator for the vehicle's engine.

Overrunning Clutch

For the torque converter to function properly, the stator or stators and the secondary members must be able to overrun. This is made possible by mounting the

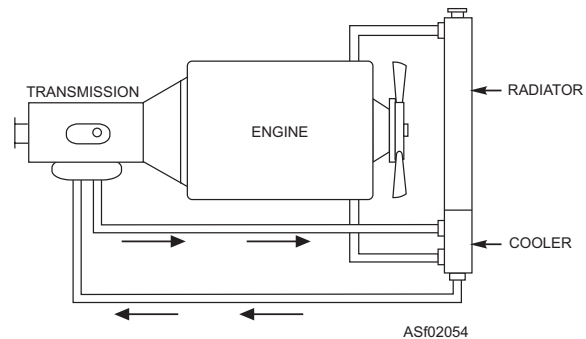

Figure 2-54.—Typical radiator-type oil cooler.

members on an overrunning clutch. In most cases, either an overrunning (one-way) clutch of the roller type or a sprag unit type is used.

A typical roller-type overrunning clutch is shown in figure 2-55. Notice the shape of the spaces surrounding the rollers in the clutch cam. When the member overruns, the rollers move against light springs into the larger spacing in the cam, thus allowing freewheeling. If the member slows down, the rollers are wedged into the smaller spaces by light springs and clutch hub rotation. This action locks the rotating member to the shaft.

A sprag unit assembly is shown in figure 2-56. This assembly consists of an inner and outer race, thrust washers, snap ring, and the required number of sprag units. The sprags (fig. 2-56, view A) are usually held in alignment and on a slight angle between the inner and outer race by an energizing spring.

The operation of a sprag assembly can be seen in detail in of figure 2-56, view B. As long as the inner or

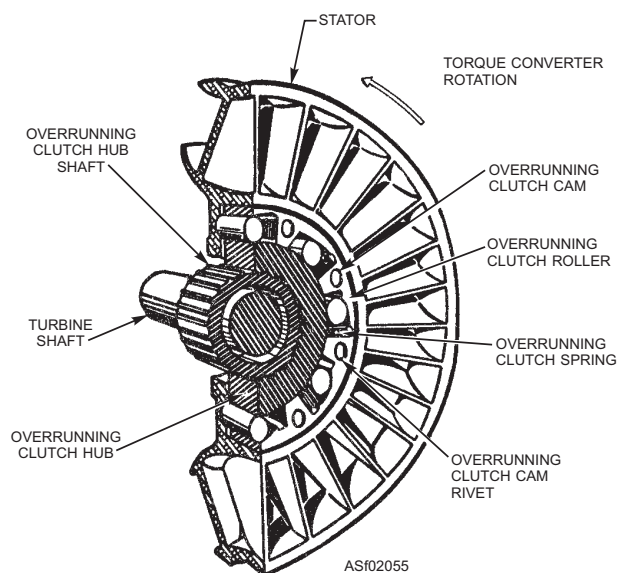

Figure 2-55.—Roller-type overrunning clutch.

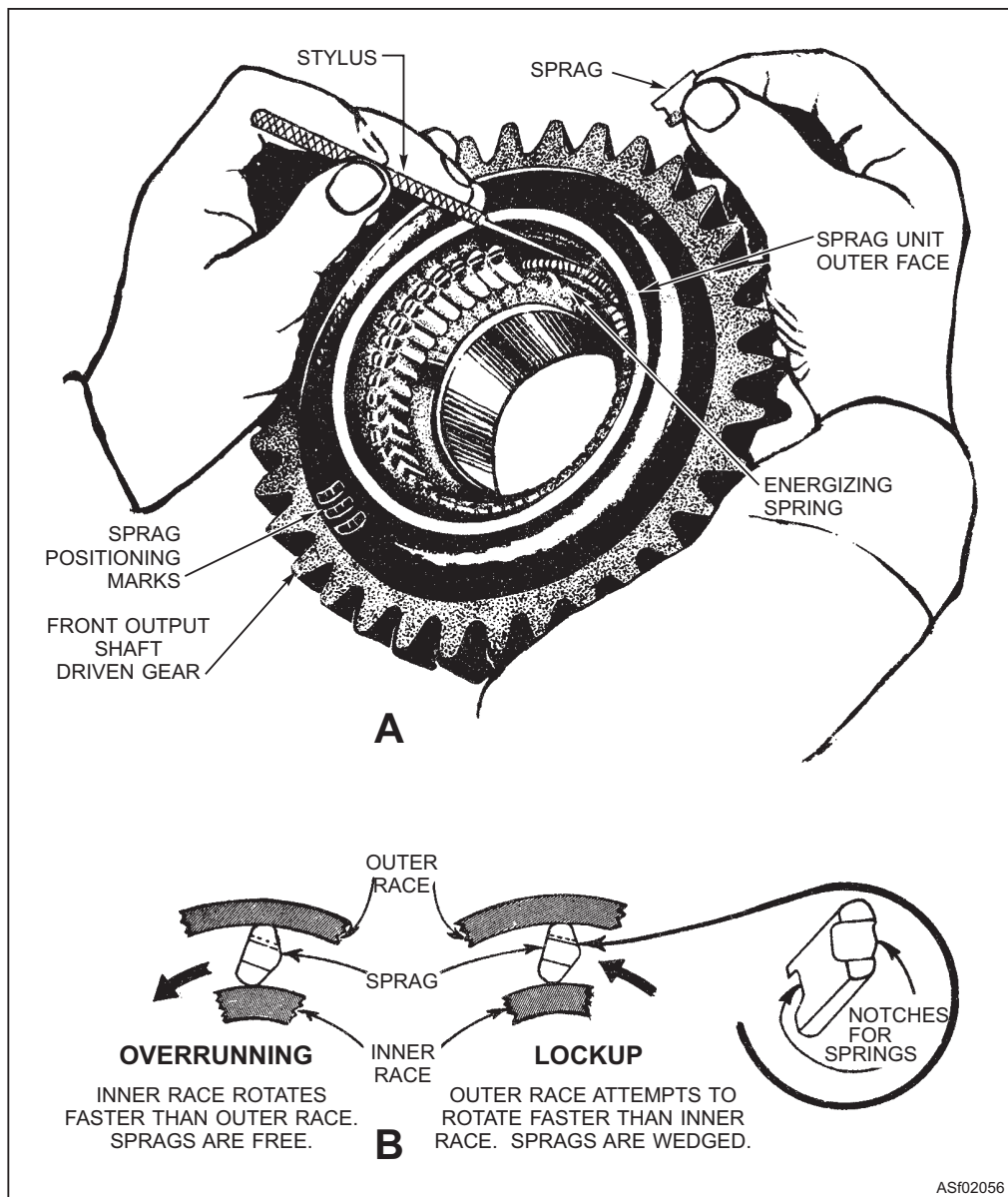

Figure 2-56.—Typical sprag assembly, overrunning clutch.

outer race rotation is with the slight angle of the sprag, the unit will overrun. However, if the inner or outer race slows down and tends to rotate against the angle of the sprag, it will jam or wedge between the two races and cause them to turn as one unit.

PLANETARY GEAR SYSTEM

Automatic transmissions use a system of planetary gears to enable the torque from the engine, coupled through torque converters or fluid couplings, to be used as efficiently as possible in meeting the power demands placed on the vehicle either by the operator or pull loads. The planetary gear units are the heart of the modern automatic transmission. Therefore, an understanding of gears and the planetary gear system is

essential for an understanding of the automatic transmission.

Gears

One of the first things that should be noted about gears is the direction of rotation. The direction that the driven gear turns is opposite to that of the driving gear when only two meshing gears are used. To have the driven gear turn in the same direction as the driving gear, an idler gear is used between the driving and driven gears. Figure 2-57 shows the direction of gear travel using an idler gear. By simply covering one of the outside gears, shown in figure 2-57, direction of gear travel can be seen for two meshed gears. The gear ratio for the gears in figure 2-57 is 1 to 1, since each

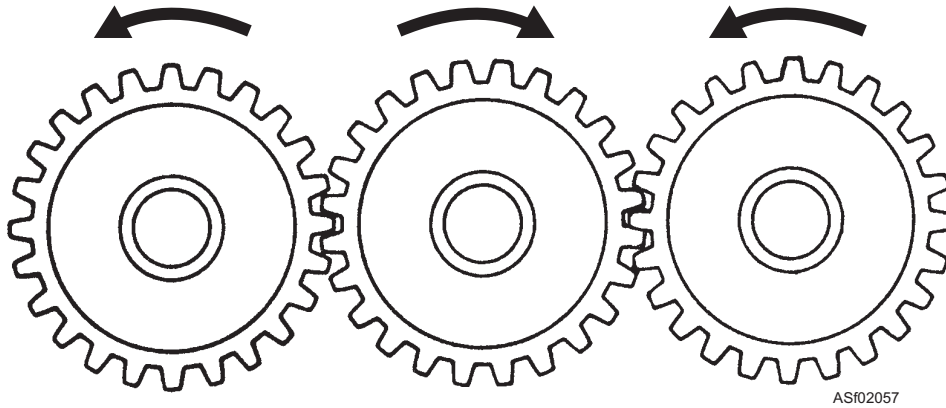

ASf02057

Figure 2-57.—Direction of gear rotation.

gear has the same number of teeth. With a 1 to 1 ratio, the driven gear rotates at the same speed as the driving gear.

Two meshed spur gears are shown in figure 2-58, with the larger gear having twice the number of teeth as the smaller gear. This arrangement produces a speed ratio of 2 to 1 with the small gear driving, since the small gear rotates twice as fast as the larger one. Thus, the gear ratio between two meshing gears is a comparison of the rpm of one gear to the rpm of the other gear.

Gears are not only used to produce speed ratios (same speed, increased speed, or reduced speed), they are also used because the mechanical advantage of gears is directly related to the gear ratio of the driving gear to the driven gear, as is the speed ratio. Therefore, if the small gear drives the gear twice its size, the mechanical advantage is 2 to 1, since the small gear must exert its torque twice the distance (two

revolutions) to turn the large gear one revolution (fig. 2-58). If the large gear drives the small gear, the mechanical advantage is 1 to 2. The turning effort required to rotate the gears is called torque. The torque ratio between gears varies with the mechanical advantage. Thus, if a small gear drives a larger gear, the speed is decreased, but the torque is increased; if a large gear drives a small gear, the speed is increased, but the torque is decreased. This shows that through a gear train, speed can be obtained by sacrificing torque, or torque can be increased by sacrificing speed.

There are numerous types of gears used throughout the vehicle power train. The most common gears found in automatic transmissions are the spur and helical gears. The gears shown in figures 2-57 and 2-58 are SPUR gears. The HELICAL gear differs from the spur gear in that its teeth are cut at an angle to the sides of the gear, while the spur gear teeth are cut straight and at right angles to the side of the gear.

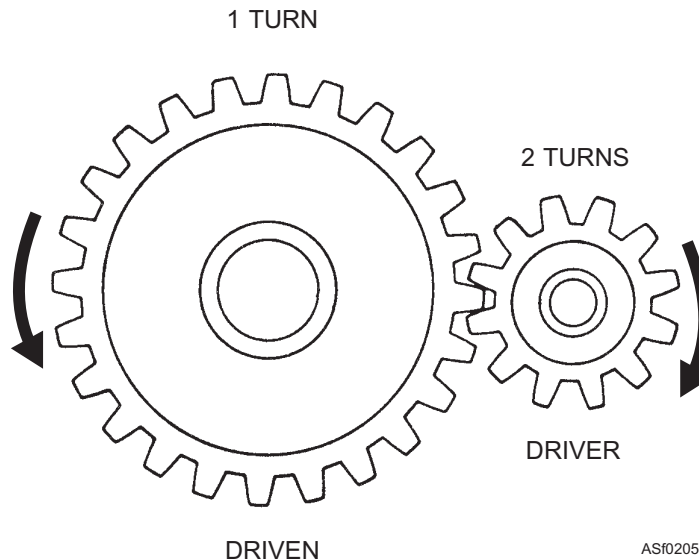

ASf02058

Figure 2-58.—Gear speed ratio.

Helical gears in mesh have more tooth contact area in contact and operate quieter than spur gears.

Another gear common in the planetary gear system of automatic transmissions is the RING gear or internal gear. In this gear the teeth face toward the center of the gear instead of outward. The teeth can be of the spur or helical configuration.

Planetary Gears

The planetary gear set consists of three separate, but interconnected, rotating members or gears. Figure 2-59 shows a planetary gear set. Notice that the outer gear, or ring gear, is an internal gear because the gear teeth point inward toward the center. The inner gear is called the “sun” gear. The gears between the internal gear and sun gear are called “planet pinion” gears; they are held in place by the planet pinion carrier. This gear system is called the planetary gear system because the planet gears can rotate and at the same time revolve around the sun gear.

Drums, hubs, and shafts can be used to put torque (power) into any one of the three members and, at the same time, hold other members so the gear ratio through the system can be increased or decreased. In addition, by the proper turning and holding arrangement, the system can reverse rotation.

Only one of the members can be the input, another the output, and one must be stationary. If any two members are locked together, the entire planetary gear system is locked out, and the input shaft and the output

shaft must turn at the same speeds, thus producing a direct drive or ratio of 1 to 1. If no member is held stationary and no two members are locked together, then the system will not transmit power at all. The input shaft may turn but the output shaft will not. The most common method of holding the members of a planetary gear system is through the use of clutches or bands.

There are several combinations of speed/torque ratios available through a planetary gear system. Figure 2-60 shows a chart containing six different conditions that can result in the planetary gear system by holding or turning the various members. For example, the column under condition 1 shows that holding the sun gear while turning the pinion carrier causes the ring gear to turn faster than the pinion carrier. When the pinion carrier is turned, the pinion must walk around the sun gear because the gears are meshed with the sun gear. The pinion gears are also

CONDITION	1	2	3	4	5	6
SUN GEAR	H	H	T	IR	I	T
PINION CAGE	T	L	L	H	T	H
RING GEAR	I	T	H	T	H	LR

ASf02060
 H - HOLD
 T - TURN
 R - REVERSE
 I - INCREASE OF SPEED
 L - REDUCTION OF SPEED

Figure 2-60.—Chart of the speed ratio combinations in a simple planetary gear system.

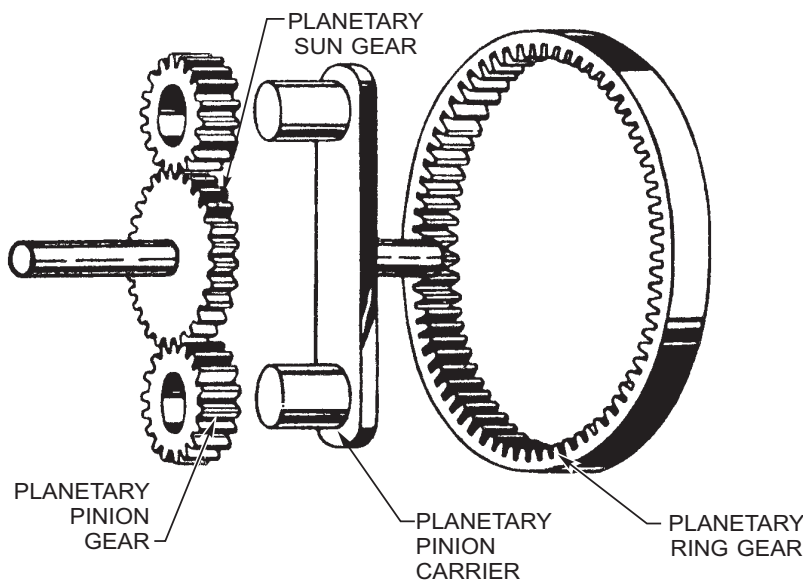

ASf02059

Figure 2-59.—Members of a simple planetary gear system.

meshed with the ring gear; as they walk around the sun gear (while rotating) on their shafts, they force the ring gear to rotate at a speed increase. Not all of the conditions shown in figure 2-60 are used in vehicle transmissions, but they should be studied for full understanding of the planetary gear system. Figure 2-61 shows the six conditions referred to in fig. 2-60. Notice condition 6 in both figures 2-60 and 2-61; this is

a very common condition found in transmissions, since speed reduction is desired in a reverse situation.

There are two additional conditions. One condition is **DIRECT DRIVE**, whereby any two members are locked together giving a drive ratio of 1 to 1. The other is **NEUTRAL**, whereby torque is simply blocked because no member is held stationary (the gears rotate but there is no torque transmittal).

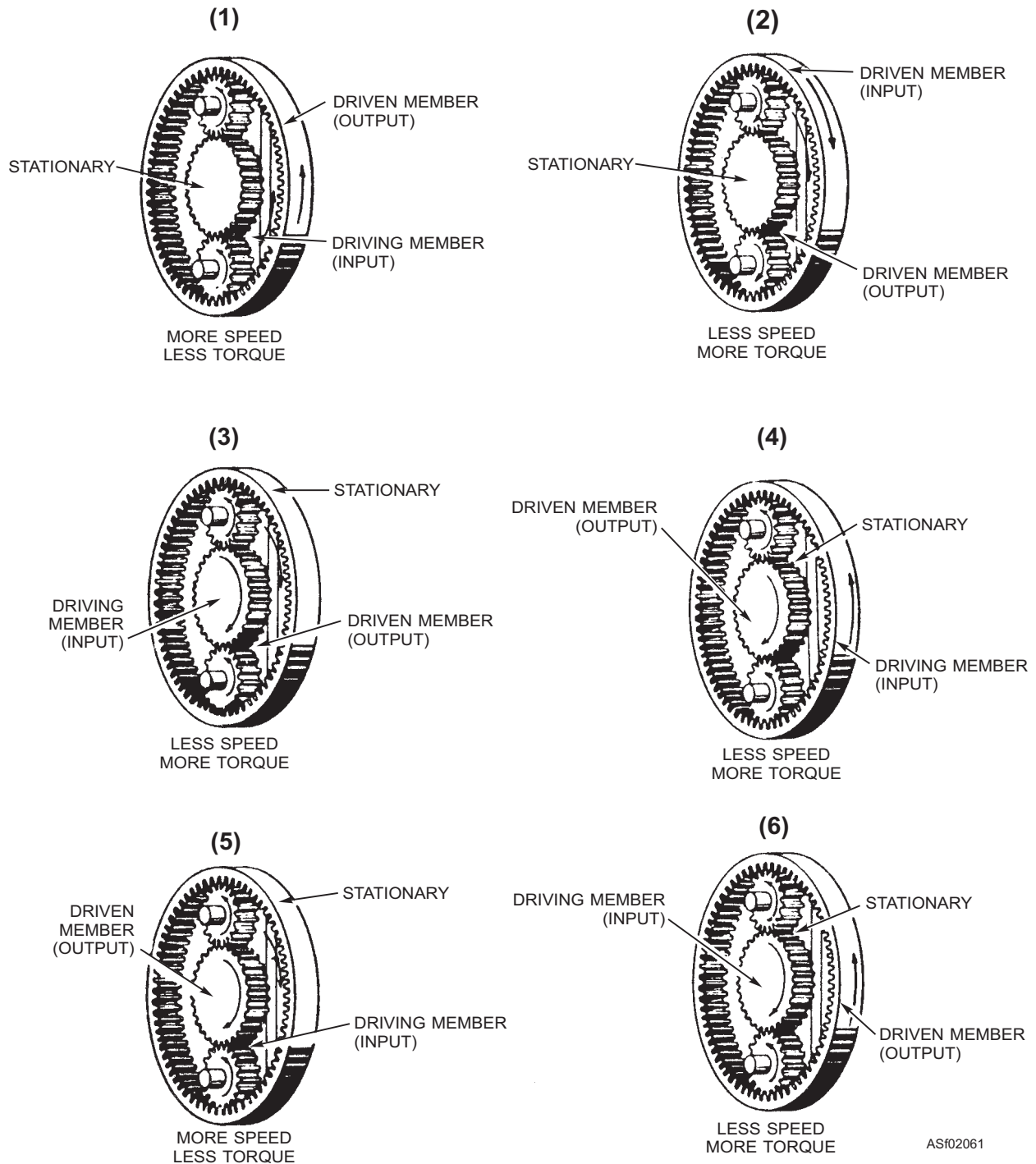

Figure 2-61.—Views of six speed/torque ratios for a simple planetary gear system.

Complex Planetary Gear System

As in the case of simple machines, complex planetary systems are merely combinations of two or more of the simple planetary units. Planetary units can be arranged to provide several different conditions or gear ratios. However, only two of these conditions can be used for each unit—either direct drive and a gear reduction, or reverse and direct drive. This shows that a single planetary unit is actually a two-speed transmission. All that is needed to operate the unit is a way to hold any one member to provide a reduction in speed (torque increase), and a way to lock any two members together for direct drive. Of course, the single unit would not provide the tractive torque and variable speeds necessary on some types of support equipment. For this reason most automatic transmissions contain two or more planetary units (complex planetary system) arranged to provide the required tractive torque for starting and moving heavy loads, and also providing variable forward speeds as well as a reverse gear.

There are inherent advantages to the planetary gear system. For example, since each gear of the planetary unit is in contact with at least two other gears of the unit, there is a lot of gear tooth contact to carry the load. Another advantage is that the gears are always in mesh, and there is no tooth damage due to tooth clash or partial engagement. However, the big advantage, and the one that makes it so popular, is the ease of shifting gears, which can be done automatically.

CONSTRUCTION OF AN AUTOMATIC TRANSMISSION

The components of an automatic transmission can be divided into four groups—the torque converter, the range or gearing section, the operating units, and the hydraulic control units. These four groups are shown in figure 2-62. The torque converter and range or gear section incorporating the use of a planetary gear train (two or more planetary units) were discussed earlier. Therefore, only the operating units and hydraulic control units are discussed in depth in this section.

Operating Units

The operating units of the transmission are the servos and clutches. The servo unit (fig. 2-63) consists of the servo body (containing the cylinder, piston, and return spring) and the friction band (attached to the body), which is used to stop or hold a rotating drum or retainer. The servo simply converts the hydraulic

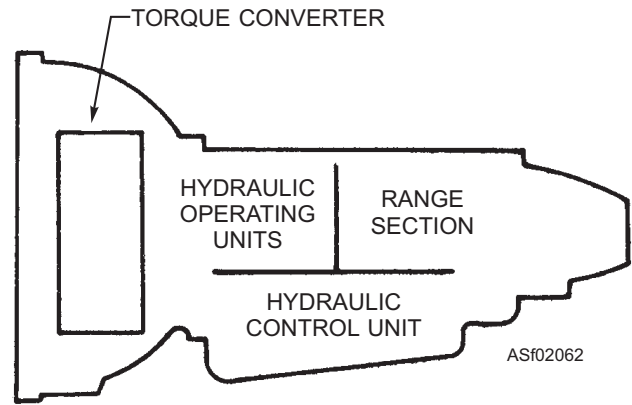

Figure 2-62.—Representative transmission groups.

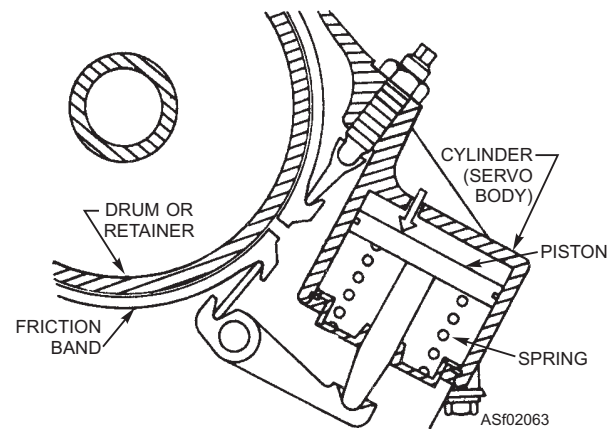

Figure 2-63.—Servo unit.

pressure applied to the piston into mechanical force, thus controlling the application of the brake (friction) band. When the brake band is applied, a member of a planetary gear unit is held stationary, providing a specific gear ratio.

The clutches, like the servo units, normally use hydraulic pressure for their actuation and a return spring for release. Clutches can be of various designs, but most are the multiple friction disc type (fig. 2-64). The clutch discs can be wet or dry—the major

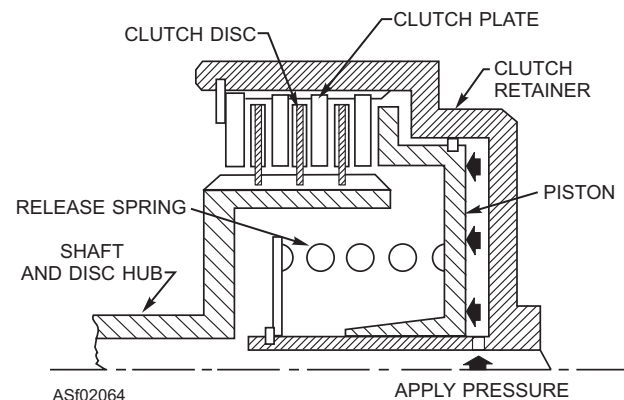

Figure 2-64.—Multiple disc clutch unit.

difference being that the disc of the wet disc must be bathed in oil to function. The disc face of either type (wet or dry) is covered with friction material, generally a bonded sintered bronze facing. The discs are splined to a hub, and the hub is splined to a shaft. The steel clutch plates are mounted between the friction discs and are splined to a clutch housing or retainer. The clutch plates and disc are commonly referred to as a clutch-pack. The clutch retainer contains the actuating piston and return or release spring. When hydraulic pressure is applied to the clutch piston, the discs and plates are squeezed together and rotate as a unit. The release spring is also compressed at this time. When hydraulic pressure is removed from the piston, it is returned to the release position by the release spring. This causes the discs and plates to separate.

The clutch hub is attached to one member of a planetary gear unit, while the clutch retainer is attached to another member of the same planetary unit. Therefore, when the clutch discs and plates are squeezed together causing these two units to rotate as one unit, the planetary gear unit is in direct drive (1 to 1 ratio). The clutch is used for holding two planetary members, while the servo unit holds only one.

Hydraulic Control Units

In the manual selective type of transmission, the operator must select the gear ratio he or she thinks is best for engine load and vehicle speed. However, in the automatic transmission, it is the job of the hydraulic

control units to make the right selection (gear ratio) for the engine load and vehicle speed and to make the selection at the right time.

A typical system of hydraulic control units consists of many components. Some of these components sense vehicle speed, others sense engine power, some supply hydraulic pressure, and still others regulate and control the hydraulic oil and pressure. A typical system of hydraulic control units is shown in figure 2-65. Most of the transmission's valves and oil passages are housed in the control units. The control units are usually made up of several valve bodies bolted together, or the valve bodies are mounted on a metal plate that has the oil passages machined or cast into the plate and valves.

The front pump, driven by the torque converter at or near engine crankshaft speed, is usually mounted on the transmission input shaft at the front of the transmission. The pump delivers oil from the sump (transmission oil pan), through a filter, to the proper hydraulic control units for routing to the operating units as directed by the various valves.

The regulator valve maintains a controlled oil pressure to the control units. The manual valve permits the operator to manually select the desired operating range. The shift valve initiates the upshifting or downshifting as determined by the governor and throttle pressures. The throttle valve is positioned by the accelerator linkage; therefore, it is sensitive to engine speed.

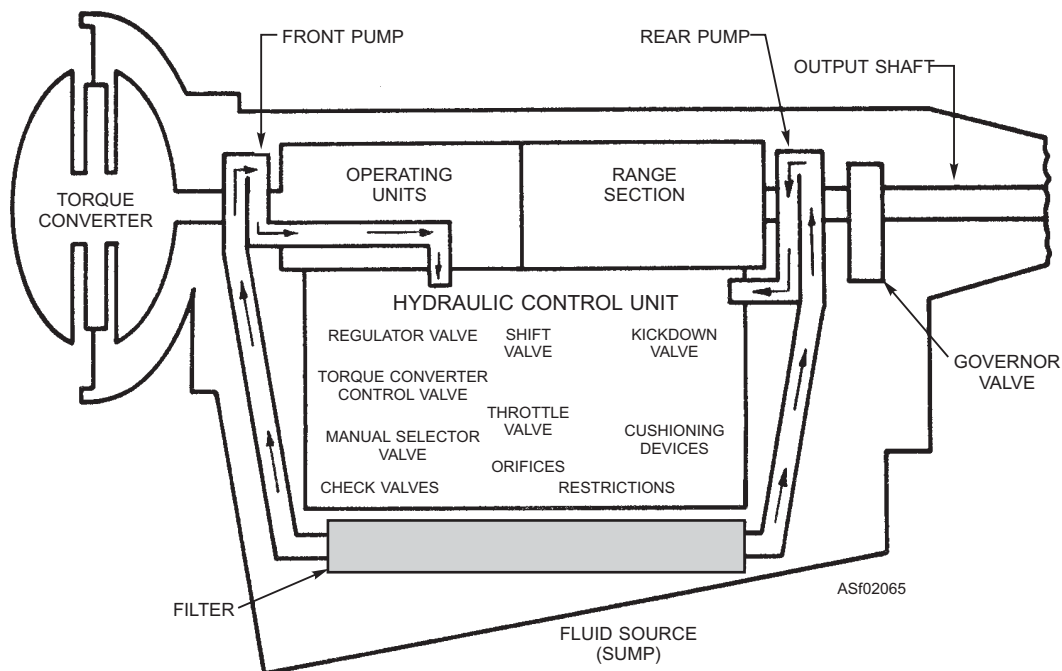

Figure 2-65.—Typical hydraulic control unit and its components.

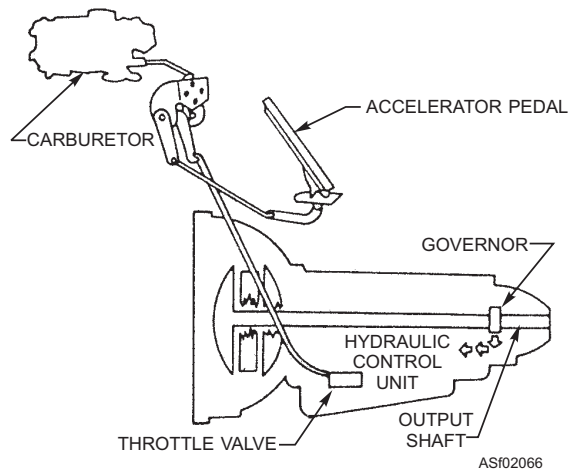

Figure 2-66.—Typical throttle valve and linkage.

Figure 2-66 shows a typical throttle valve and linkage. The throttle valve delays the upshifting and regulates oil pressure proportional to the accelerator pedal position or carburetor throttle opening. The governor valve causes the upshifting and regulates oil pressure proportional to the transmission output shaft speed.

The kickdown valve provides a means of forcing a downshift to a lower gear ratio when it is desirable, such as when accelerating rapidly. The torque converter control valve controls the pressure and flow of oil to the torque converter and to the lubricating passages of the transmission. Valves, metering orifices, or restrictions are added to the hydraulic system to help time and smooth out the operations of the transmission.

HYDRAULIC CONTROL SYSTEM

The hydraulic control system makes the transmission fully automatic, and to do its job completely, must consist of a fluid source, pressure supply system, hydraulic operating units, and control units for regulating both fluid flow and pressure.

The fluid source is the fluid contained in the transmission oil pan, normally referred to as a sump. The fluid is strained through a filter as it flows from the sump to the pump or pumps.

The hydraulic system must maintain the oil under pressure for its various components to function properly. It is the job of the pump or pumps to remove oil from the sump and deliver it under pressure to the systems. The pumps can be of several different designs, however, most manufacturers use the internal gear, constant displacement pump.

In some transmissions only one oil pump may be used, and it is mounted at the front of the transmission. However, most manufacturers of support equipment use a pump at both the front and rear of the transmission. This allows the vehicle to be “push started,” whereas with the single pump, “push-starting” cannot be accomplished, since the engine must be operating to drive the torque converter and the pump.

WARNING

Pushing or pulling a vehicle equipped with an automatic transmission is extremely dangerous and can result in damage to the equipment and injury or death to personnel. A vehicle equipped with an automatic transmission should not be pushed or pulled except in an extreme emergency, and then only after all possible precautions are taken to eliminate the dangers involved.

Pressure Regulator

Oil from the pumps must be delivered to the operating units under regulated pressure. To obtain this regulated pressure, a pressure-regulating valve is incorporated into the system pressure line. Figure 2-67 shows an oil pressure regulator. Oil from the pump or pumps flows to the chamber between two lands of a spool valve. Movement of the valve in one direction is limited by a mechanical stop. Movement in the other direction is limited by a spring calibrated to the required system pressure (usually around 80 to 90 psi).

As shown in figure 2-67, oil flows from the chamber of the regulator valve to the manual valve and back to the rear of one large land in the regulator valve. This area of the regulator valve is known as the secondary reaction area. Also notice there is an oil flow from the pumps to the rear of the small land of the secondary reaction area. This area is known as the primary reaction area. In looking at the two reaction areas, notice the working areas of the lands. There will be no regulated pressure (at least not 80 to 90 psi) until oil has reached the secondary reaction area of the valve.

After the oil has entered the secondary reaction area, the force of the oil acts on both the large and small lands in the area. When the pumps have supplied sufficient pressure, the resulting force acting on the large land of the secondary reaction area moves the valve to the left against the spring. This movement

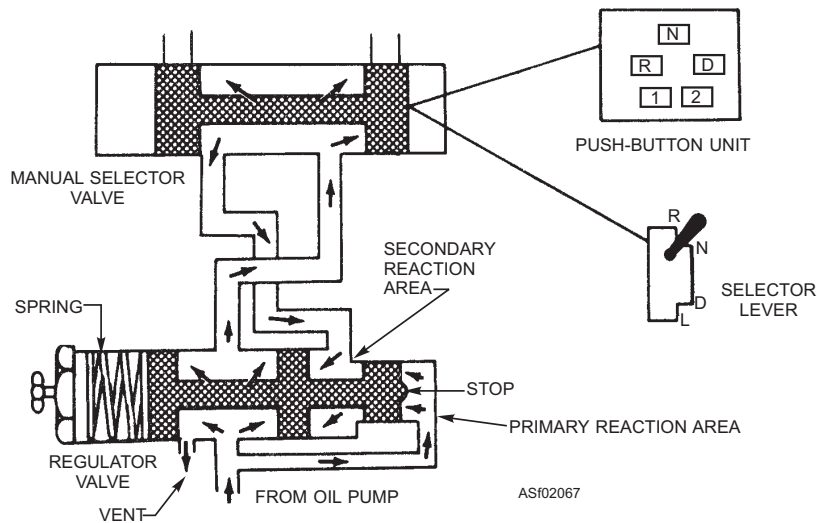

Figure 2-67.—Oil regulator.

uncovers a vent port that bypasses oil back to the suction side of the pump or the sump. The valve seeks and stabilizes at a pressure that balances the setting of the spring. The oil that is delivered to the control system by the regulator valve is known as the line or main line pressure.

Manual Selector Valve

The oil pump (or pumps) and pressure regulator provide the hydraulic system with the fluid and pressure necessary to operate the transmission operating units. However, to control the transmission, a valve controlled by the operator is required. This operator-controlled valve is commonly called the “manual valve.” The manual valve can be positioned by the operator to provide low-gear ratios, or low- and high-gear ratios, reverse, and neutral; on some transmissions an intermediate range of ratios can be selected as well as park. The operator may use a selector lever or a push button to control the valve (fig. 2-67).

The manual valve acts as a directional control valve. It blocks fluid flow and pressure to the operating units while in the neutral position; in other positions, it directs oil to one or more of the operating units.

Governor

A governor is normally mounted on the output shaft of the transmission, rotating with it; therefore, it is sensitive to the speed of the vehicle. Because the governor is sensitive to the speed of the vehicle, it is used to transmit fluid under pressure, proportional to

the vehicle speed. There are two types of governors in general use—the centrifugally operated spool valve and the fluid velocity type. Figure 2-68 shows both a fluid velocity and a centrifugally operated governor.

The centrifugal governor usually consists of a weight and valve assembly enclosed within the governor housing. The spool valve is free to move inside the cylinder or bore of the housing within the

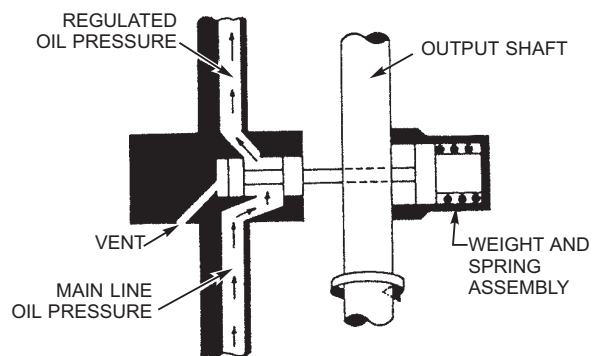

A. CENTRIFUGAL GOVERNOR

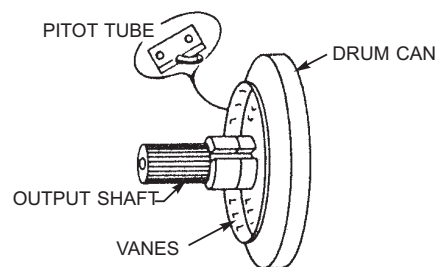

B. FLUID VELOCITY GOVERNOR

ASF02068

Figure 2-68.—Centrifugal and fluid velocity governors.

limitations of the spring-loaded weight. The governor housing rotates with the output shaft. At no speed or low speed, the spring is able to keep the valve positioned to prevent fluid flow or restrict it to a very small amount. As vehicle speed increases, so does the centrifugal force acting on the weight. When sufficient force acts on the weight, it moves outward against the spring and allows more fluid flow (greater pressure). As more pressure is built in the governor output line, it is also being built up between the spool lands of the governor valve. The result is to position the valve by spring pressure and pressure acting on the spool lands (one larger than the other) to balance the centrifugal force acting on the weight.

The fluid velocity governor consists of a pilot tube that is fixed (stationary), and usually sits between two sets of vanes in an oil-filled drum. The oil drum (can) is mounted on the transmission output shaft and rotates with it. The pilot tube is a small tube open at both ends and curved on the end inserted into the oil. This tube does not rotate with the oil drum. As the drum rotates, its vanes propel the oil into the stationary curved pilot tube. The velocity of the oil entering the pilot tube is directly proportional to the speed of the output shaft. Thus, it is capable of transmitting hydraulic pressure sensitive to the vehicle speed.

The governor's oil pressure causes the upshifting of the transmission (higher gear ratio), but the throttle valve pressure (fig. 2-66) opposes or delays the upshifting. However, the pressures from the throttle and governor valves are not sufficient to operate the servos and clutches effectively. Therefore, these

pressures are used to control another valve, which, in turn, controls a regulated pressure sufficient to operate the servos and clutches. The valve controlled by the throttle and governor pressures is called a shift valve.

Shift Valve

The shift valve, located in the hydraulic control unit, moves to up shift the transmission gear ratio when governor pressure becomes greater than throttle pressure. As shown in figure 2-69, with the shift valve in the up shift position, ports in the valve body are uncovered, allowing oil from a regulated pressure source (normally line pressure) to pass unrestricted to one or more of the operating units. Energizing one or more of the operating units causes a change in the planetary gear ratio. By using throttle pressure (reflecting engine speed), governor pressure (reflecting vehicle speed), and a shift valve to control the operating units, gear shifting is automatic.

The shift valve shown in fig. 2-69 is a spring-loaded, spool-type valve. It has two lands of equal area and one larger area land. When the transmission is in neutral (no hydraulic oil going to any of the control units), the shift valve spring moves the valve to the right, blocking the clutch port. This means that the valve is always set so the vehicle will start forward in the low position of the shift valve, and only up shift when governor pressure exceeds throttle pressure. As the vehicle moves forward, governor pressure will be directed to the rear area of the large land in the shift valve. When the governor

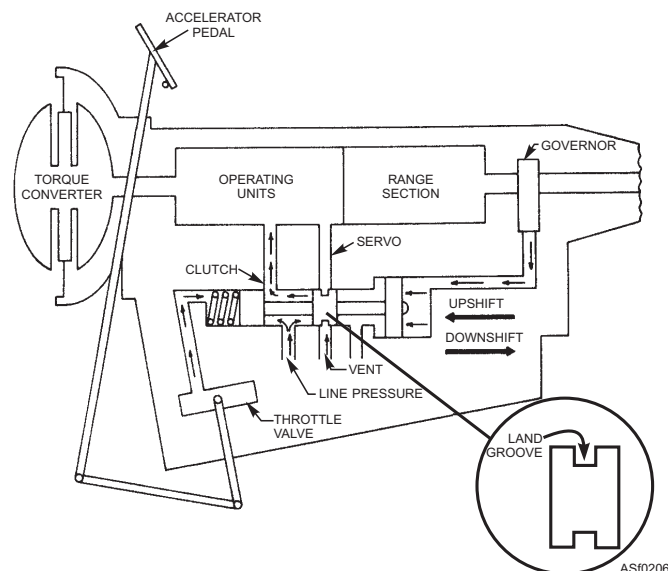

Figure 2-69.—Shift valve.

pressure force is greater than the throttle pressure force, the shift valve will move, uncovering the clutch port and at the same time closing the servo pressure port. This causes the clutch to actuate and place the transmission in an up shift position. Both the servo and clutch will have some method of venting trapped oil back to the sump. The method of exhausting the trapped fluid varies with the many manufacturers. Some use ball-check valves, others use metered orifices, and still others cut grooves around the valve lands for oil return. (Notice the servo port land in figure 2-69 for an illustration of a grooved land for oil return.)

Throttle Valve

The governor valve causes an upshift in the transmission. If there was no opposing or balancing oil pressure, the transmission would always upshift at the same vehicle speed. However, to give the operator more control over the shifting of the transmission and to lessen overloading of the engine, a throttle valve is incorporated into the hydraulic control system (fig. 2-70). This valve directs oil pressure to oppose the governor pressure, and thus delays upshifting.

The throttle valve is operated manually by the operator through the accelerator pedal linkage. One end of the valve contains a spring and a moveable plug. When the accelerator pedal moves the linkage, the plug is moved and thereby varies the tension on the valve spring. The force of the spring acting on the spool valve increases with an increasing carburetor throttle opening.

In operation the throttle valve receives oil flow from the manual selector valve. Oil enters the area between the large lands of the throttle valve and also goes into the shift valve oil passage. Oil is also allowed to enter a reaction area at the small end of the valve. Oil pressure builds up in the throttle valve circuits until the oil pressure in the reaction area is sufficient to force the

valve against the valve spring. The valve moves against the spring until the vent (return) port is opened enough to balance the forces acting against the reaction area land and the spring tension acting on the other end of the valve.

The regulated oil pressure from the throttle valve is directed to the spring-loaded end of the shift valve. Thus, the throttle oil pressure adds to the shift valve spring pressure to hold the shift valve in the servo position. This action is opposed by the governor oil pressure. Therefore, an increased throttle pressure setting requires an increased governor oil pressure (greater vehicle speed) to cause an up shift.

It is sometimes desirable while operating in direct drive (up shift), and even at full throttle, to downshift for better acceleration, load control, emergencies, and so on. To accomplish this downshift, the hydraulic control system uses a kickdown valve.

Kickdown Valve

The shift valve at this point has two oil pressures (throttle and governor), which act to control the time of transmission shifting according to vehicle speed and throttle opening. What is needed now is a method of getting the required oil pressure to an area of the shift valve that will cause the shift valve to move to a downshift position, even at full throttle. To get the required oil pressure and control its flow to the shift valve, the hydraulic system uses what is commonly called a "kickdown valve." The kickdown valve, like all other valves found in the automatic transmission, can vary in design from manufacturer to manufacturer. It may be an integral part of the throttle valve, or a separate valve arrangement. It may use piston-type valves or ball-check valves. For our purpose, a separate valve arrangement containing a spring and ball is used (fig. 2-71). The oil comes from the manual selector valve into a chamber or housing, where the spring-loaded ball stops oil flow. The ball is connected to the throttle linkage. The throttle linkage can unseat the ball and allow oil flow into an oil passage leading to the shift valve.

The throttle valve, the governor valve, and the kickdown valve directly control the shift valve. Figure 2-72 shows how these valves function to control the shift valve.

As shown in figure 2-72, the oil (when the kickdown valve ball is unseated by the rod) is allowed to flow from the kickdown valve through a passage to a chamber of the shift valve. At this time the throttle

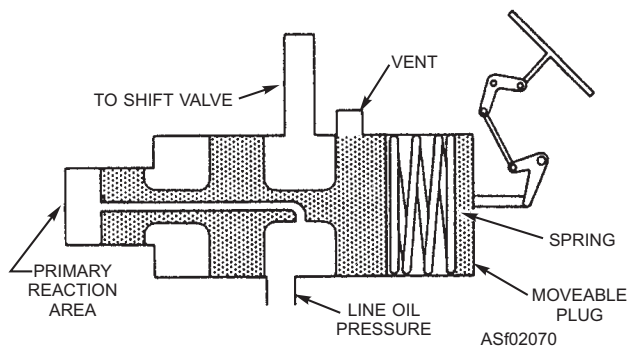

Figure 2-70.—Throttle valve.

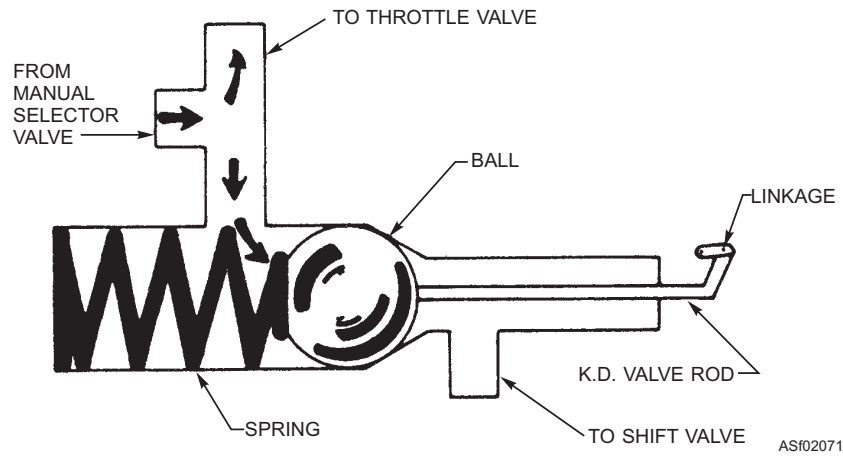

Figure 2-71.—Kickdown valve (separate valve arrangement).

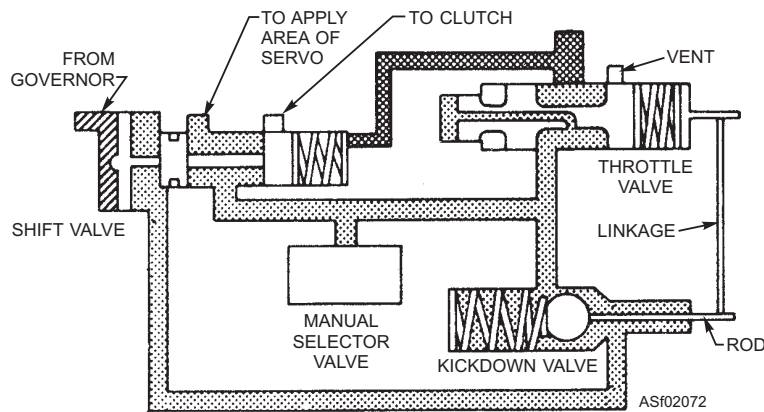

Figure 2-72.—Functional shift valve controls.

valve is fully open (maximum throttle oil pressure). At the same time, the governor pressure is high (higher than the throttle pressure because the kickdown valve is needed for downshift). Notice in the figure that the kickdown oil pressure, while acting on both a small and large surface area of the shift valve, will have a resulting force that acts in direct opposition to the governor oil pressure. What we have is kickdown oil pressure, throttle oil pressure, and the spring tension of the throttle end of the shift valve acting against governor oil pressure. The shift valve moves to uncover the servo port (downshift position) and at the same time release the clutch. Reseating of the kickdown ball, by releasing the accelerator pedal, will cause the transmission to again up shift.

The kickdown valve is unseated normally just a little beyond full throttle. There is usually a device installed to indicate to the operator that the accelerator pedal has reached the point of kickdown. The device is generally a spring or hydraulically loaded plug, which offers resistance to accelerator pedal movement after reaching full throttle. This is a very desirable feature, since the vehicle may at times have to be operated at

full throttle with kickdown operation. When the operator feels the resistance, he or she knows the accelerator is at full throttle. Further movement, called “going through detent,” causes kickdown.

Operating Ranges

The hydraulic control system will shift automatically depending on vehicle speed and load conditions, except for reverse operation. The operator is able to control the timing of transmission shifts and make a forced downshift when necessary. For reverse operation, another planetary gear unit is added. To operate the reverse planetary unit, another operating unit (servo) is added. The different gear ratio changes discussed are D for direct drive, L for low range, N for neutral, and R for reverse operation.

NEUTRAL RANGE.—The neutral position (N) is the no-power-flow position of the transmission. The neutral position is selected by the operator by placing the manual selector lever or push button in N. Most vehicle engines will not start unless the N position has been selected.

There is no power flow through the transmission in neutral. However, the oil pump is functioning to provide oil for the torque converter and, at the same time, developing a regulated line oil pressure to be used when other transmission ranges are selected. Figure 2-73 shows the neutral position for a typical transmission.

Notice in figure 2-73 that there are two pumps—a front pump and a rear pump. The front pump operates any time the engine is running and furnishes oil flow and pressure for all of the hydraulic circuits except the governor. The rear pump, driven by the output shaft, furnishes oil for the governor and assists the front pump, when necessary. Check valves are used to

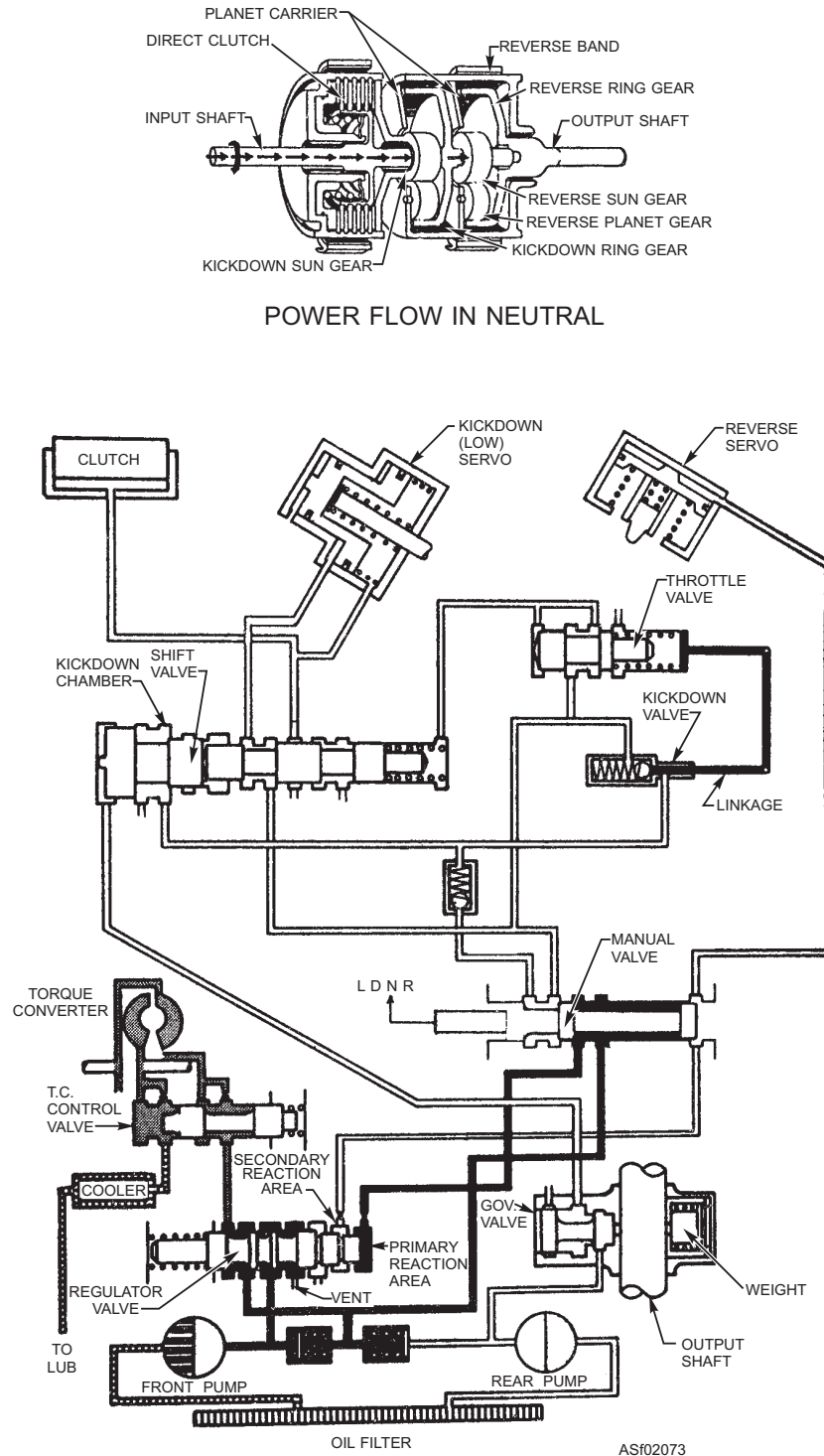

Figure 2-73.—Neutral (N) operating range.

prevent one pump from trying to drive the other in case of failure. (If the check valves were not there and a pump failed, the other pump would pump its oil through the failed pump and into the sump.)

Oil from the front pump is directed to the torque converter (TC) control valve. The TC valve regulates the oil flow and pressure for the torque converter and the transmission lubrication circuits. Oil is also directed from the pump to the regulator valve and the manual selector valve. Oil is directed from the manual selector valve back to the primary reaction area of the regulator valve. When the oil pressure is high enough in the reaction area, it will move the regulator valve against the valve spring and, at the same time, vent some of the oil flow back to the sump. When the valve has positioned itself to balance the spring tension and the oil pressure in the reaction area, the line oil pressure is regulated.

Figures 2-73, 2-74, 2-75, 2-76, and 2-77 show a drawing of the clutch, kickdown (low) servo band, reverse servo band, and planetary gear sets (including the reverse planetary unit). Notice in the drawings how the planetary units are held or driven by use of hubs, housings, and hollow shafts. As each operating range is discussed, take note of the power flow through the planetary units.

LOW RANGE.—Low range (L) is the gear ratio selected by the operator when it is advisable to keep the transmission in low gear for an extended period of time. Low range is selected manually, by placing the selector lever or push button in the L position. This operating range is shown in figure 2-74.

Through linkage from the selector lever, the manual selector valve has been moved to a position that opens oil passages going to the shift valve and then to the servo. One oil passage goes to a check valve and then to the kickdown chamber of the shift valve, which causes the shift valve to remain in a downshift position. The other oil passage passes oil through the shift valve servo passage to the low/kickdown servo unit. Thus, the transmission is in low gear and will remain in this condition as long as the selector lever is in the L range. Governor oil pressure is developed during this operation, but it is not able to move the shift valve against the main-line oil pressure in the kickdown chamber. Throttle valve oil pressure is also applied to the shift valve, which aids the kickdown chamber oil pressure in opposing the governor oil pressure.

DRIVE RANGE.—The operator, by moving the selector lever to the drive (D) range, allows the

transmission to start in low range and automatically up shift to a higher range at the proper time. In selecting the drive position, the manual selector valve is moved to cover the oil passage that feeds line oil pressure into the kickdown valve chamber of the shift valve, as shown in figure 2-75.

The shift valve will remain in the low range position (held by spring tension and throttle valve oil pressure) until the governor oil pressure is sufficient to move the shift valve against the throttle valve oil pressure. Governor oil pressure increases proportional to the vehicle speed.

When governor oil pressure is high enough, the shift valve will move. Movement of the shift valve closes the servo oil passage and uncovers the clutch oil passage. Notice in figure 2-75 that when the clutch is engaged there is also a release of oil pressure applied to the servo. This prevents the clutch from engaging before the servo is completely released. With the clutch engaged, the transmission is operating in a 1 to 1 gear ratio, or direct drive.

If, while operating in direct drive, it is desirable to make a forced downshift—that is, go into kickdown—the operator simply pushes the accelerator pedal through full throttle (detent). When the throttle is forced through detent, mechanical linkage moves the kickdown valve rod, forcing the kickdown valve ball off its seat, as shown in figure 2-76.

When the kickdown ball is unseated, main-line oil pressure is directed to the kickdown chamber of the shift valve. At the same time, maximum throttle oil pressure is acting against the up shift end of the shift valve. The combined force of line pressure from the kickdown valve, assisted by throttle pressure and spring force at the up shift end of the shift valve, is now sufficient to overcome the high governor oil pressure. Therefore, the shift valve is forced into the downshift position, the clutch is released, and the low-speed servo band applied. The transmission is then in gear reduction, or low range. When the accelerator is moved to a position less than full throttle, the kickdown ball is again seated by spring force. Oil pressure is no longer directed to the kickdown chamber, and once again the shift valve is moved by governor pressure to an up shift position.

REVERSE RANGE.—Most transmissions operate efficiently at a regulated line pressure of 80 to 90 psi. This is true for forward drive conditions only. For reverse operation the working line pressure must be increased to handle (prevent slipping) the high

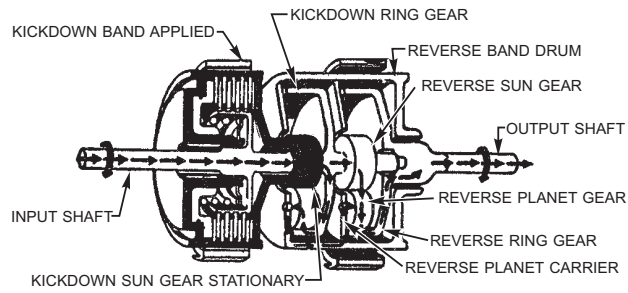

POWER FLOW IN BREAKAWAY, KICKDOWN OR LOW

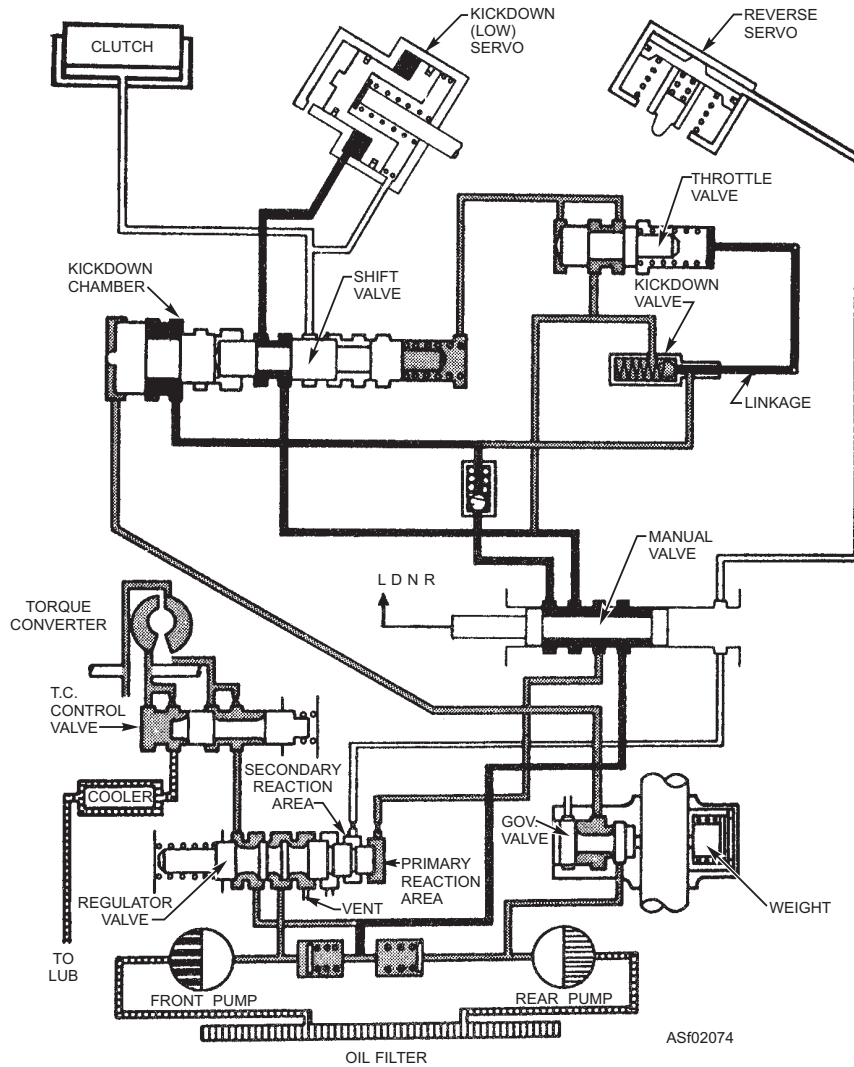
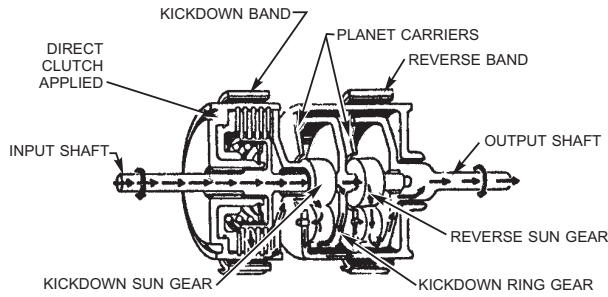

Figure 2-74.—Low (L) operating range.

torque loads that are imposed on the operating unit—that is, the clutch or servo used to drive or hold the reverse member of the planetary gear set. This oil pressure increase is accomplished by movement of the manual selector valve and use of a smaller reaction area in the regulator valve.

To operate the vehicle in reverse, the operator moves the manual selector lever to the reverse (R) position, as shown in figure 2-77. Linkage moves the manual selector valve, opening a passage leading to the reverse operating unit. At the same time, an oil passage to the regulator primary reaction area is closed, and an



POWER FLOW IN DIRECT DRIVE

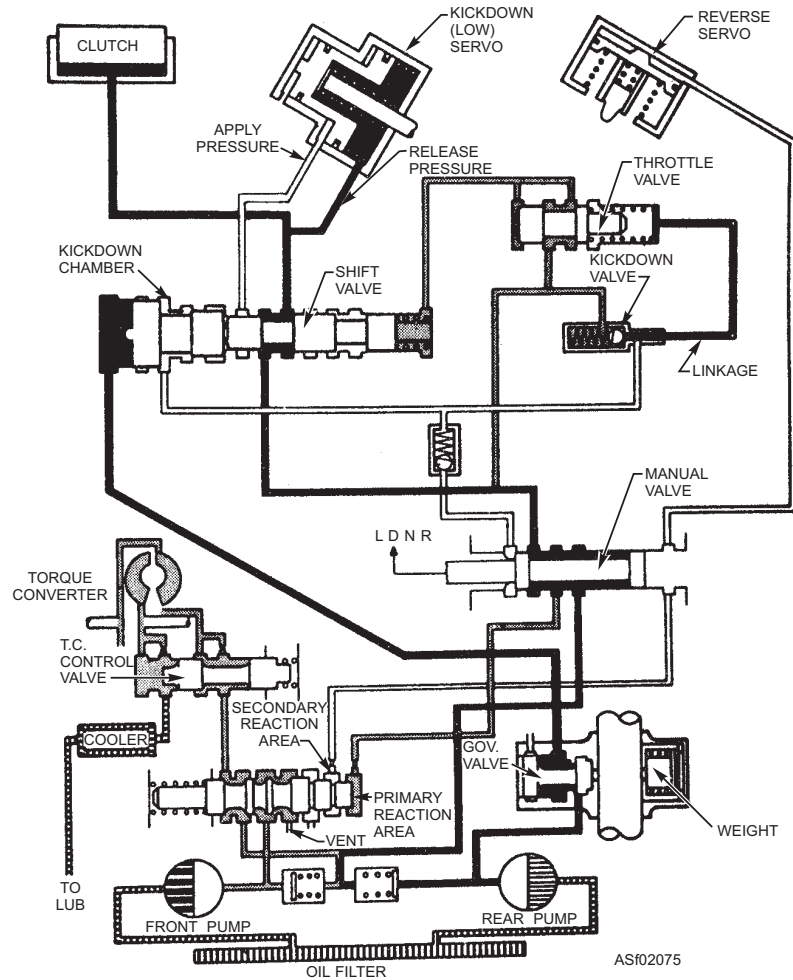

Figure 2-75.—Drive (D) operating range.

oil passage directing oil to the smaller (or secondary) reaction area of the regulator valve is opened.

As shown in figure 2-77, the oil passage to the primary reaction area of the regulator is closed off. With this condition, and having oil from the pump directed to the small land area of the regulator valve,

more working oil pressure must be applied to the small land to cause the valve to operate. Therefore, a greater pump pressure is required and produced to move the regulator valve against the valve spring. The regulated oil pressure in the reverse range is usually between 200 and 300 psi. This increased oil pressure is directed to the reverse servo unit; all

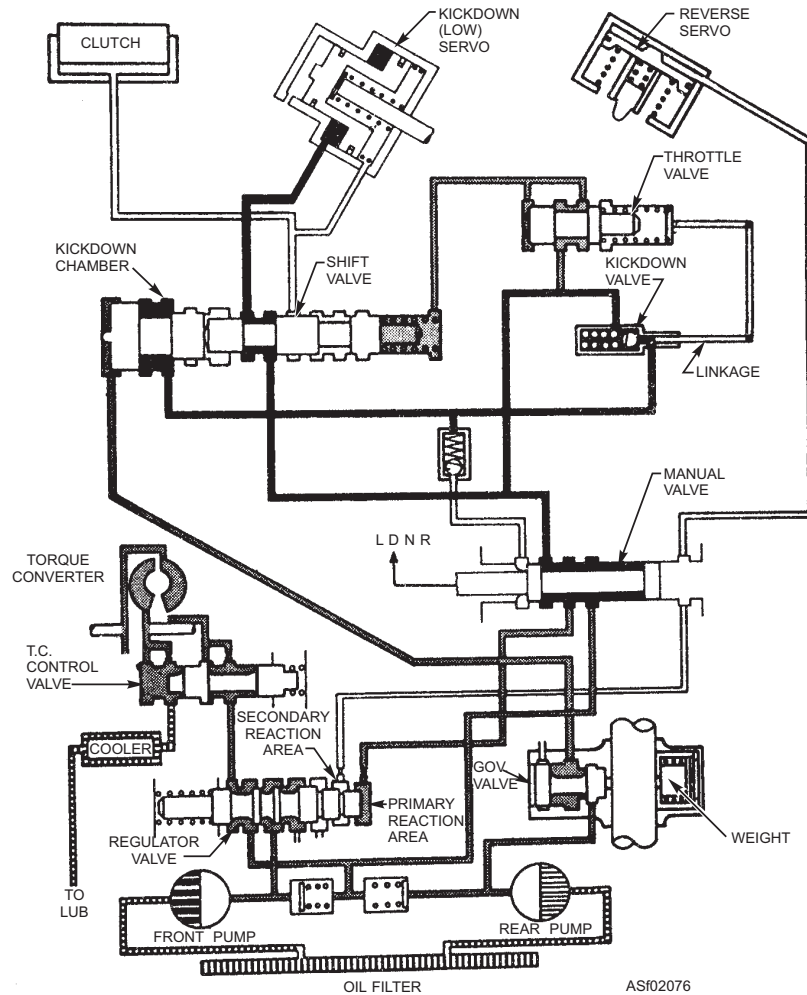
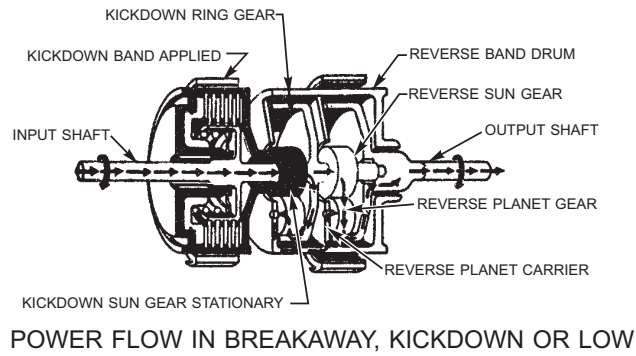

Figure 2-76.—“Kickdown” forced shift position.

other oil passages not concerned with reverse have been closed off.

DEVICES REQUIRED FOR SMOOTH OPERATION

The transmission discussion to this point has covered the required essentials of a basic automatic

transmission. However, the performance would leave much to be desired. For instance, shifting would be rough and erratic, and the life of the transmission would be shortened. Therefore, each manufacturer adds certain refinements or devices in the form of valves, orifices, check valves, metering devices, timing devices, and so on, to smooth out the operation

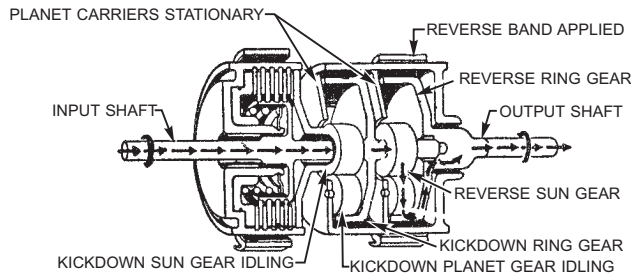

POWER FLOW IN REVERSE

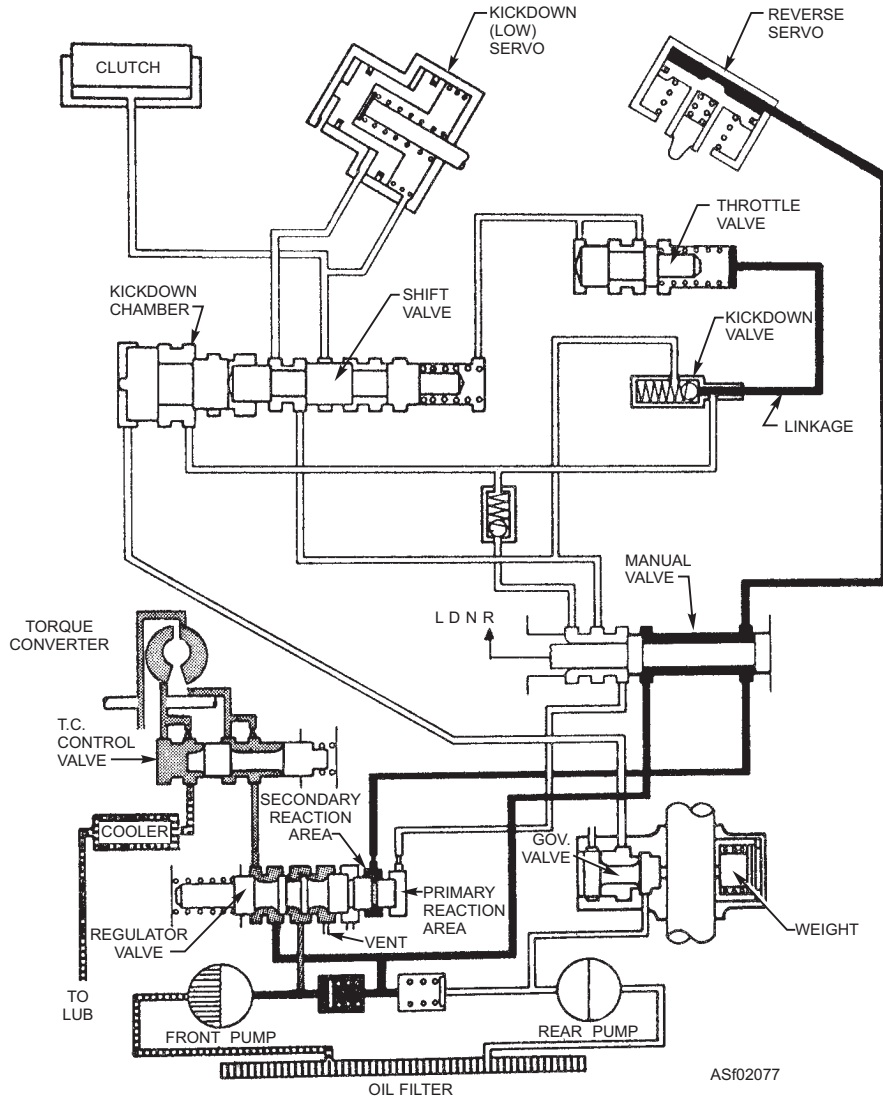

Figure 2-77.—Reverse (R) operating range.

of the transmission. For example, a device is needed that will cushion the application of the operating units (clutches and servos) to prevent harsh engagement. The device used by most manufacturers to cushion (time) the operating units is the shuttle valve. The

timing devices are necessary to regulate the time of filling and venting the operating units.

On some transmissions the manufacturer uses a device to prevent the transmission from being shifted into reverse while the vehicle is moving forward. This

device, known as a blocker valve, is usually hydraulically operated. The blocker valve normally requires the vehicle speed to be below a certain speed before reverse can be selected.

Some transmissions use a lockup clutch with the torque converter. This clutch is usually located between the turbine and the pump (impeller) drive housing and is applied by oil pressure controlled by the transmission hydraulic control units. When the converter reaches the coupling stage, oil pressure is directed to the lockup clutch, causing it to engage. The lockup clutch locks the turbine and pump together at coupling stage speed for a positive 1 to 1 ratio.

Transmissions with several forward speeds and a reverse normally use a device known as the high and low splitter. This device consists of a planetary gear set, and hydraulic control units are used to lock two members of the planetary gear set together for direct drive, or to hold one member for low gear ratio. The output from the splitter assembly is passed to the other planetary units, and thereby gives several gear ratios for each combination of planetary units.

Another device used on some automatic transmissions is known as the hydraulic retarder. This device is used on heavy duty vehicles to assist the brake system in slowing down the vehicle, such as when descending steep grades. The retarder, usually located at the front of the transmission behind the torque converter, is controlled by a foot pedal in the operator's area. Through linkage, the pedal is connected to a control valve mounted on the side of the transmission that cuts off or supplies oil to the retarder.

The retarder consists of a cavity or housing with vanes cast into the housing and a rotor with integral blades. The rotor is connected to and turned with the output (turbine) shaft of the torque converter. When the operator depresses the foot pedal, oil is directed into the cavity surrounding the rotor. The oil source for the retarder unit is from the torque converter. The oil strikes the rotor blades in a direction opposite to that in which the rotor is turning. This produces the same effect as turning a paddle wheel in the opposite direction from that in which a stream of water is turning the wheel. That is, the oil is churned by the action of the rotor and the vanes in the cavity. This churning of oil tends to put a drag on the output shaft of the torque converter. Therefore, anytime the retarder is used, it tends to help the vehicle brake system.

CAUTION

If the retarder is used for a long period of time, it tends to overheat the transmission oil. Usually a warning light is mounted on the operator's instrument panel to indicate high oil temperature. When the light comes on, the retarder should be disengaged to allow the oil to cool.

TRANSMISSION MAINTENANCE

Maintenance and repair of automatic transmissions may sound like a complicated job, but with the proper tools, test equipment, replacement materials, and "know-how," these units can be maintained properly. Before disassembly of a transmission due to internal malfunction, you should investigate the availability of a quick engine change (QEC) for that unit, ensure sufficient parts and technical information are available, and ensure the urgency of need is there to justify the teardown. It is quite time-consuming to disassemble an engine, make a repair, and reassemble the engine only to find the engine requires additional internal repairs.

The automatic transmission, like any other hydraulic system, depends, as a very important first step, on its oil supply. The oil must be of the correct type, must be at the proper level, and most important, must be clean.

Contaminated oil can clog oil lines and passageways and restrict valve movement in the hydraulic control unit. A high or low oil level usually causes the transmission to overheat and results in eventual failure. Some transmission failures have been a direct result of oil leaks; therefore, all oil leaks should be corrected as soon as possible after being detected.

There have been instances when the transmission was removed from the vehicle for repair unnecessarily; the defect could have been corrected without transmission removal. For example, the transmission output shaft seal, speedometer drive pinion, oil pan gasket, or oil cooler can normally be corrected without transmission removal. On some transmissions the servo units and governors may also be repaired or replaced without removing the entire assembly. In all cases every possible effort should be made to make repairs without transmission removal from the vehicle.

The manufacturers of automatic transmissions normally recommend a step-by-step procedure for testing the transmission in the vehicle. These

procedures are designed to determine proper functioning and to assist in isolating and diagnosing transmission troubles.

Figure 2-78 shows a typical automatic transmission, showing the range or gearing section, operating units, hydraulic control unit (valve body), torque converter, pumps, governor, and transmission case. Optional devices such as lockup clutches, high-low splitters, and retarder units are not shown.

You should be familiar with several terms used by the manufacturers in describing maintenance procedures for various transmissions. The term *apply-passage* means a passage through which oil pressure is applied to an operating unit. *Air-check* simply means substituting air pressure for oil pressure and applying it to the apply-passage for checking an operating unit. Another term is *gauging-hole*, which refers to holes provided in adjacent parts to hold them in alignment or in a certain position by a gauge pin or rod. While the parts are held by the gauge pin, certain adjustments can be made.

A detailed step-by-step discussion of the possible repairs that can be performed or how they are performed for the many automatic transmissions is

beyond the scope of this training course. However, there should be a manufacturer's repair manual available in the work center for the specific transmissions for which you have maintenance responsibility. These service and repair manuals should be followed very closely in performing all transmission maintenance and repair. The maintenance discussed in the following paragraphs is general in nature and presented to give you a better understanding of overall transmission maintenance.

Adjustments

In maintaining the automatic transmission, adjustments are necessary for satisfactory performance. Adjustments are required after the repair of a transmission and periodically while in service. The manufacturer usually specifies the time interval between most adjustments, and these recommendations should be followed. The adjustments discussed in the following paragraphs are the ones most commonly found on automatic transmissions.

Control linkage adjustment is the adjustment of the selector linkage to the manual control valve. The

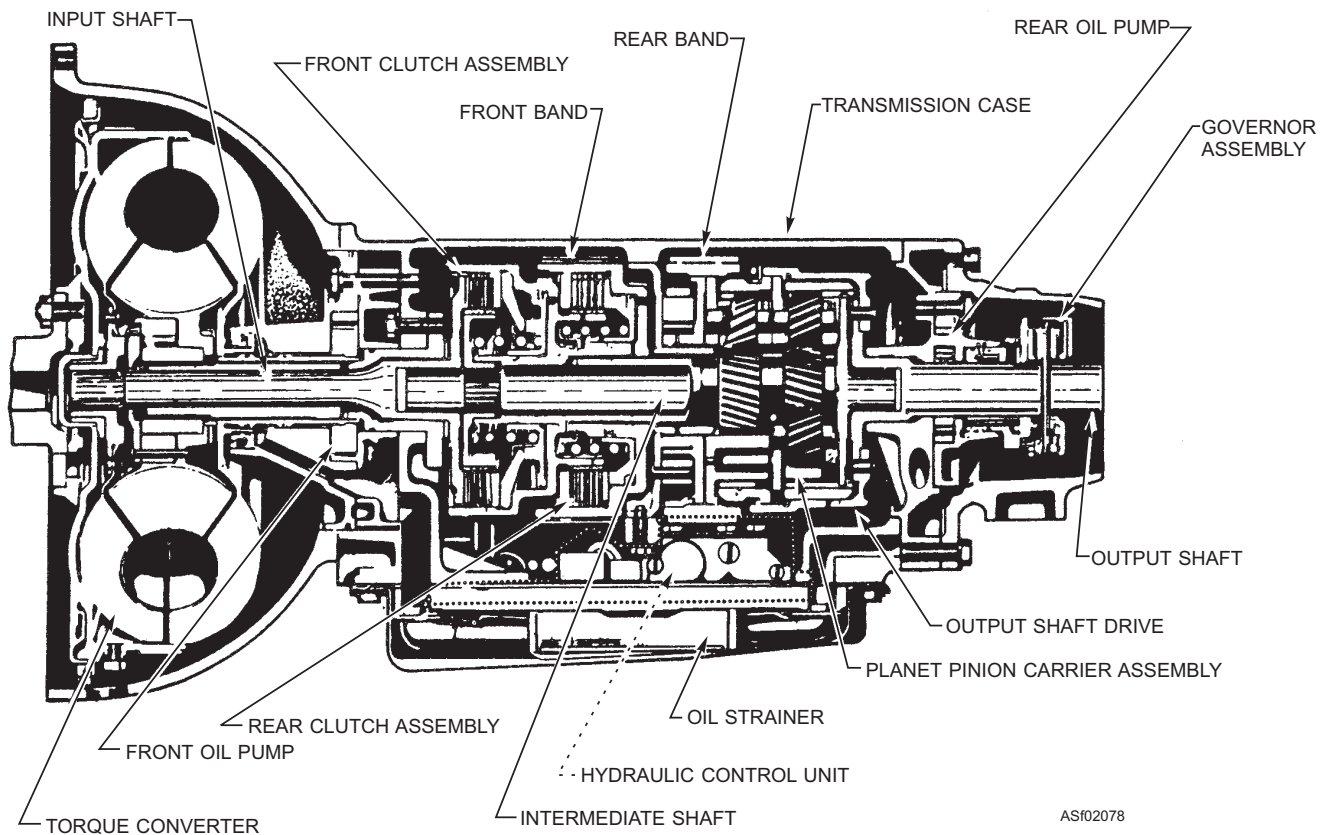

Figure 2-78.—Typical automatic transmission.

adjustment varies for different vehicles; therefore, the technical manual for the vehicle should be consulted for this adjustment.

Throttle linkage adjustment is the adjustment of the control rod from the throttle valve on the transmission to the accelerator linkage at the engine carburetor. This adjustment is very difficult to set until the engine has been properly adjusted, because the engine speed affects the throttle valve pressure.

Band adjustments are made periodically as specified by the manufacturer. Some transmissions allow band adjustments from the outside of the transmission case, while others require removal of the oil pan before the bands can be adjusted. In all cases, for trouble-free operation the bands should be adjusted at the time interval and by the procedures specified by the manufacturer.

Oil Checks

When checking an automatic transmission, most manufacturers suggest you start with the oil level in the reservoir. Next, make an oil pressure check on the various hydraulic circuits. For example, to check the main line or regulated oil pressure, connect a pressure gauge to the specified check point on the transmission and operate the engine at the specified rpm with the transmission in neutral (N). This test can be used to check the condition of the pressure regulator or pump.

OIL LEVEL CHECKS.—This check is made to determine if there is sufficient oil in the reservoir to supply the demands of the torque converter or fluid coupling plus the other needs of the transmission. To make the test, most manufacturers recommend operating the engine and transmission until they have achieved the normal operating temperature. Usually, when the engine temperature is normal, so is the transmission oil temperature.

Before taking a reading of the oil level, operate the transmission through its ranges and then place the selector in the N position. Remove the bayonet gauge (dipstick) from the transmission and check to see if the oil is at the right level. If the level is low, fill it with the correct type of oil to the correct level. If the level is too high, it should be drained until the correct level has been reached.

Different transmission manufacturers may recommend different positions for the shift lever during this check. In case the manufacturer recommends that the lever be in the D position, the

wheels should be chocked and the brakes set during the oil level check.

OIL PRESSURE CHECKS.—Oil pressure checks are performed to determine if sufficient pressures are available to the operating units to cause them to operate properly. The main thing in making oil pressure tests is to use a pressure gauge that will handle, without damage, the pressures being tested. Another important point is to be sure of the pressure check point on the transmission, as each hydraulic circuit may require a different pressure for a certain operation.

Torque Converters and Fluid Couplings

Torque converters and fluid couplings normally require very little maintenance. However, oil seals and gaskets may fail occasionally, thus requiring maintenance. For maintenance other than oil leaks, the fluid coupling or torque converter is replaced as a unit, if it is a sealed unit. If it is not a sealed unit, limited repair and parts replacement may be authorized.

If maintenance requires the disassembly of a unit, it should be thoroughly inspected. In most cases all seals and gaskets should be replaced with new ones during reassembly. Components of the unit, such as a pump, turbine, stator, one-way clutch, and so on, should be replaced if they show signs of excessive wear or are defective.

Range Section

The range section (planetary sets) of a disassembled transmission should be inspected for chipped teeth, wear patterns, and worn support bearings. The thrust washers should also be inspected, and replaced if they show signs of excessive wear. If the bearings are defective, or any member of the planetary set is defective, replace the gear set.

Operating Units

A clutch is usually used to hold two members of a planetary gear set, and a servo band is used to hold one member. Normally, a defective clutch or servo (slippage) can be detected by road testing the vehicle. The manufacturer's recommendations should be followed for road testing a specific vehicle. If a clutch or servo is defective, it normally will require transmission removal from the vehicle to perform maintenance (except for servo band adjustment).

A “no drive” condition might exist in a transmission, even with correct oil pressure, because of inoperative clutches or bands. Therefore, before removing a clutch assembly or a servo unit from the transmission, check it with air pressure.

The front or rear clutches and kickdown (low) servos may be tested by applying clean, moisture-free compressed air of 30 to 100 psi to the apply-passages. Figure 2-79 shows a typical oil passage arrangement as seen after the removal of the hydraulic control unit (valve body).

Apply air pressure to the apply-passage and listen for a dull thud, which indicates that the clutch or servo is operating. In some cases the thud may not be heard in the clutches; in this case, place the fingertips on the clutch housing, and movement of the clutch piston can be felt when the clutch is applied. If, by applying air pressure, the clutches and servos operate properly, but allow slippage under road testing, then the trouble is probably in the band, band adjustment, or the clutch disc. If air can be heard escaping through the clutch or servo unit, a seal or gasket is defective and must be

replaced. A defective clutch disc usually requires replacement of the entire clutch assembly.

Hydraulic Control Unit

Foreign matter in the hydraulic control unit is one of the major causes of an automatic transmission malfunction. A particle of dirt or a piece of lint could cause a valve within the unit to partially stick or seize in the valve body. This would cause the transmission to operate improperly, depending upon which valve was sticking. If a malfunction or troubleshooting indicates a defect in the hydraulic control unit, the entire unit should be disassembled, cleaned, and inspected. All defective parts should be replaced.

While the inspection of parts is mostly visual, the springs contained in the unit should be checked for proper length and pressure and for such defects as distortion and broken coils. Upon disassembly, it is good practice to place the parts on a large piece of hard-surfaced paper. The nomenclature of each removed part should be written adjacent to the part. This is to prevent interchanging parts that look alike. A

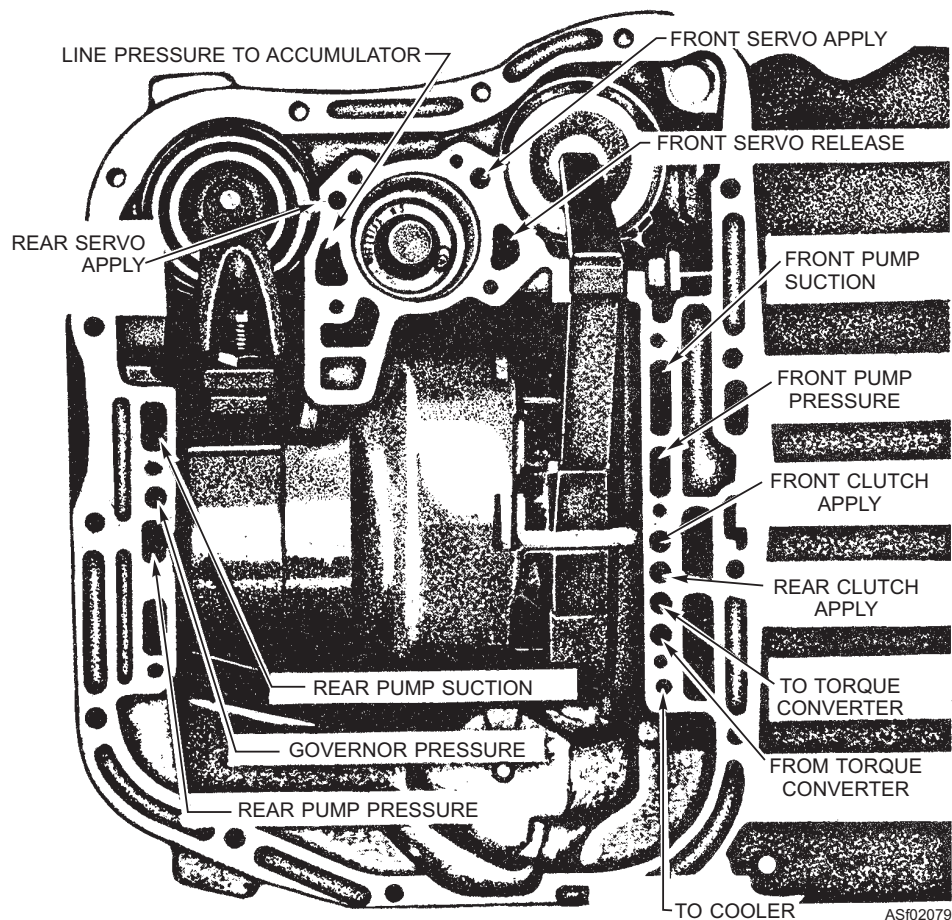

Figure 2-79.—Typical transmission oil passages.

typical hydraulic control unit (valve body) is shown in figure 2-80.

Other hydraulic system components such as pumps, lockup clutches, retarders, high-low splitters, governors, and oil pressure regulator valves, if separate from the unit, are disassembled, cleaned, inspected, and repaired in a very similar manner to the components of the hydraulic control unit.

Before reassembly of the control unit, all parts should be cleaned with the proper solvent and blown dry with clean, moisture-free, low-pressure compressed air. If compressed air is not available, the parts should be drip-dried. You should NEVER wipe the parts with any type of material that may leave lint.

Table 2-1 is a troubleshooting chart that lists many of the typical problems that occur with automatic transmissions. The table also includes probable causes for the problems and suggested remedies. The intent is always to try to solve the problem before tearing down the unit for repair or replacing it.

Transmission Removal

The procedures for removal and replacement of transmissions vary depending on the model that you are dealing with. Therefore, an in-depth discussion will not be provided here, just a few things that are common to all transmissions.

First, in some models it is easier and faster to remove the engine and transmission as one unit. After the engine and transmission are removed, the transmission can be disconnected from the engine.

Prior to removing the transmission, it should be drained of fluid, all lines disconnected and plugged, all linkages disconnected, and all electrical wires disconnected, if required. The drive shaft must be removed, and the tail shaft plugged or bagged and taped to prevent fluid from spilling as the unit is removed.

Automatic transmissions are very heavy. Many models weigh over 200 pounds, so you must have the proper sling or transmission jack to raise or lower the unit.

Upon installation, make sure that all mounting brackets are in place, and that hardware is secured prior to removing the supporting unit (sling or jack). Then, reconnect the lines, wires, linkage, and drive shafts according to the technical manual for the transmission.

Service Diagnosis and Repair of Automatic Transmissions

The transmission should not be removed nor disassembled until a careful diagnosis is made, the definite cause determined, and all possible external corrections performed. In diagnosing any abnormal

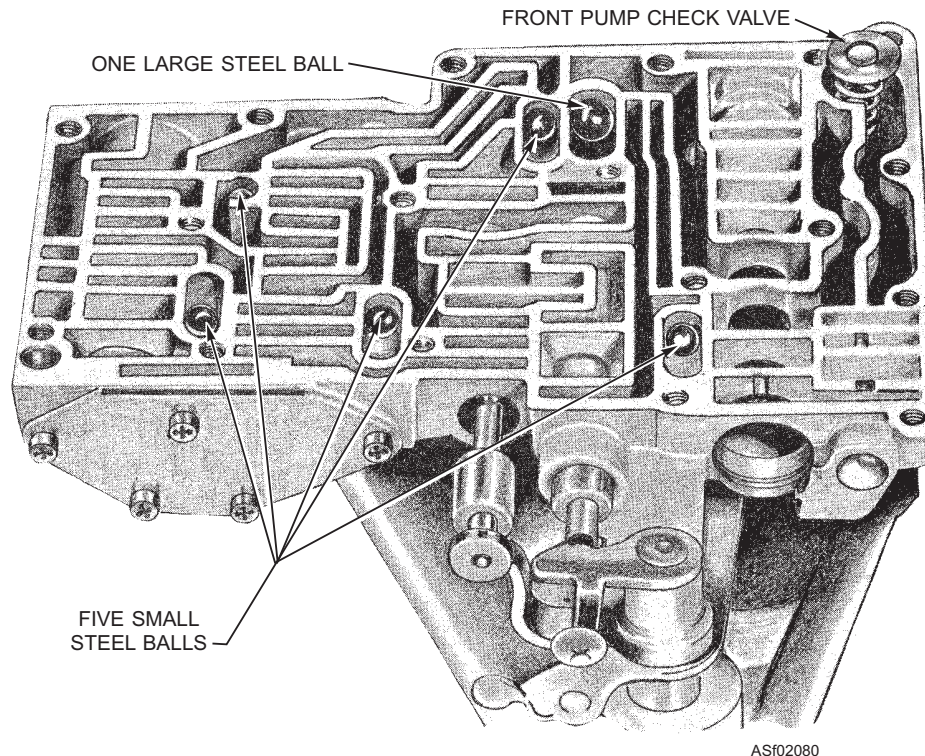

Figure 2-80.—Typical hydraulic control unit.

Table 2-1.—Allison Four-Speed Automatic Transmission Troubleshooting Chart

TROUBLE		PROBABLE CAUSE		REMEDY
Automatic shifts at too high a speed	1.	Governor valve stuck	1.	Clean or replace governor
	2.	Modulator cable adjustment	2.	Adjust cable
Automatic shifts at too low a speed at full throttle	1.	G governor valve stuck	1.	Clean or replace governor
	2.	Governor spring weak	2.	Replace spring
Low main pressure in all ranges	1.	Low oil level	1.	Add oil to proper level
	2.	Oil filter element clogged	2.	Replace filter
	3.	Sealring on oil pickup tube leaking or missing	3.	Install new sealring
	4.	Main-pressure regulator Valve spring weak	4.	Replace transmission
	5.	Control valve body leaking	5.	Replace transmission
	6.	Valves sticking	6.	Replace transmission
	7.	Oil pump worn or damaged	7.	Replace transmission
Low main pressure in first gear, normal pressure in other forward ranges	1.	First gear circuit of control valve body leaking	1.	Replace transmission
	2.	Excessive leaking at first and reverse piston seals	2.	Replace transmission
Intermittent buzzing noise	1.	Low oil level	1.	Add oil to proper level
	2.	Air leak at oil intake pipe	2.	Replace intake pipe seal and filter
	3.	Clogged filter	3.	Replace filter
	4.	Aerated oil	4.	Improper oil level, or improper or contaminated oil
Excessive creep in first and reverse gears	1.	Engine idle speed too high	1.	Adjust idle speed
Low lubrication pressure	1.	Oil level too low	1.	Add oil to proper level
	2.	Excessive internal oil leakage	2.	Check other pressures above; check valve body mounting bolts
	3.	Cooler lines restricted or leaking	3.	Check for kinks, leakage; replace lines if necessary
Oil leaking into converter housing	1.	Leaking engine crankshaft rear oil seal	1.	Refer to vehicle service manual
	2.	Charging oil pump, lip-type seal at torque converter, leaking	2.	Replace pump seal
	3.	Leaking sealring around body of oil pump	3.	Replace transmission
	4.	Cracked weld in converter assembly leaking	4.	Replace converter assembly
Transmission heating up in all ranges	1.	Oil level low	1.	Add oil to proper level
	2.	Oil level high	2.	Drain oil to proper level
	3.	Engine cooling system restricted	3.	Refer to vehicle service manual
	4.	Oil cooler lines restricted	4.	Clean or replace lines

Table 2-1.—Allison Four-Speed Automatic Transmission Troubleshooting Chart—Continued

TROUBLE	PROBABLE CAUSE	REMEDY
High stall speed	<ol style="list-style-type: none"> 1. Oil level low 2. Clutch pressure low 3. Forward clutch slipping (forward) 4. First and reverse clutch slipping 	<ol style="list-style-type: none"> 1. Add oil to proper level 2. Refer to low main pressures above 3. Replace transmission 4. Replace transmission
Low stall speed	<ol style="list-style-type: none"> 1. Engine not performing efficiently (may be due to high altitude) 2. Broken converter parts 	<ol style="list-style-type: none"> 1. Refer to engine manufacturer's manual or vehicle service manual 2. Replace converter assembly
Rough shifting	<ol style="list-style-type: none"> 1. Manual selector linkage out of adjustment 2. Control valves sticking 3. Modulator cable binding or improperly adjusted 	<ol style="list-style-type: none"> 1. Adjust linkage 2. Replace transmission 3. Replace cable or adjust to specification
Engine overspeeds on full throttle upshift	<ol style="list-style-type: none"> 1. Piston seals leaking or clutch plates slipping in range involved 2. Forward clutch piston seals or clutch plates slipping (all upshifts) 3. Broken sealrings on front support hub 4. Sticking governor valve 	<ol style="list-style-type: none"> 1. Replace transmission 2. Replace transmission 3. Replace transmission 4. Clean or replace governor
Excessive slippage and clutch chatter in one range (not in all ranges)	<ol style="list-style-type: none"> 1. Clutch slippage in that range clutch 2. Excessive oil leakage in range piston seals 3. Oil leakage in valve components for that particular range 	<ol style="list-style-type: none"> 1. Replace transmission 2. Replace transmission 3. Replace transmission
Dirty oil	<ol style="list-style-type: none"> 1. Failure to change oil at proper interval 2. Excessive heat 3. Clutch failure 4. Damaged oil filter 	<ol style="list-style-type: none"> 1. Change oil; install new filter 2. Check oil cooler lines 3. Replace transmission 4. Replace filter
Oil leak at output shaft	<ol style="list-style-type: none"> 1. Faulty or missing seal at output flange 	<ol style="list-style-type: none"> 1. Install new lip-type seal in bearing retainer
Slippage in all forward gears	<ol style="list-style-type: none"> 1. Low oil level 2. Low clutch pressure 3. Forward clutch slipping 	<ol style="list-style-type: none"> 1. Add oil to proper level 2. Refer to low main pressures above 3. Replace transmission
Slippage in fourth and reverse gears only	<ol style="list-style-type: none"> 1. Fourth clutch slipping 2. Broken sealrings on support assembly hub 	<ol style="list-style-type: none"> 1. Replace transmission 2. Replace transmission
Slippage in reverse and first gears; proper function in other forward gears	<ol style="list-style-type: none"> 1. First-and-reverse clutch slipping 	<ol style="list-style-type: none"> 1. Replace transmission
Vehicle moves forward in neutral	<ol style="list-style-type: none"> 1. Range selector linkage out of adjustment 2. Forward clutch failed and dragging 	<ol style="list-style-type: none"> 1. Adjust linkage 2. Replace transmission

shift condition, ensure that the engine is properly tuned, the idle speed is correct, all bands are adjusted correctly, and the control linkage is as specified. Always make the hydraulic pressure tests before any removal or disassembly. Refer to the applicable repair manual for in-depth troubleshooting, pressure check valves, and hydraulic fluid flow charts.

In recent years the Navy has introduced a program whereby an engine that requires internal engine repair is swapped out as a complete assembly (with its transmission, if applicable). The Navy supply system has contract provisions where complete engine/transmission assemblies are rebuilt and dynamometer tested by a civilian source and reintroduced back into the supply system. This concept is referred to as QEC (quick engine change), and is offered for approximately 80 percent of the SE power plant/drive train configurations, with more QECs added as the fleet requirements dictate. Before disassembly of an engine/transmission assembly due to internal malfunction, you should investigate the availability of a QEC for that unit. If a QEC is not available, then before disassembling the engine/transmission assembly, ensure that sufficient parts and technical information are available and that the urgency of need is there to justify the teardown. It is quite time-consuming to disassemble an engine/transmission assembly, make a repair, and reassemble the engine/transmission assembly only to find the engine requires additional internal repairs.

If a QEC is available for the type of equipment you are troubleshooting and you can still use the equipment until the replacement assembly is received, your best option is to order the QEC. A rebuilt transmission, if part of the QEC, will accompany the engine. The engine will be totally rebuilt with all new components, and the complete package will be dynamometer tested. Eventually most aviation ship's AVCAL and COSAL listings will authorize a QEC package to be stored on board for each type of equipment under this concept for immediate receipt and installation. Refer to the applicable NAVAIR and NAVAIRWARCEN (NAWC) instructions for the program policies and a listing of the QEC kits available.

As previously mentioned, the transmissions are part of the QEC program and will be exchanged rather than overhauled in the fleet. NAVAIRINST 13610.2 (series) (QEC instruction) lists the procuring

procedures as well as the depth of allowable repairs by the user.

Q2-21. Which of the following components can transmit torque at a ratio of 1 to 1 (direct drive) or under certain conditions, can increase torque so that more torque is delivered than applied?

- 1. The transmission*
- 2. The differential*
- 3. The torque converter*
- 4. The hydraulic multiplier*

Q2-22. What type of gear system is used by automatic transmissions?

- 1. A direct drive gear system*
- 2. An opposing gear system*
- 3. A multiplying gear system*
- 4. A planetary gear system*

Q2-23. The gears that are located between the internal gear and the sun gear are referred to as what type of gears?

- 1. The planet pinion gears*
- 2. The internal connecting gears*
- 3. The ring gears*
- 4. The orbiting gears*

Q2-24. Which of the following components in an automatic transmission is responsible for making the right gear ratio selection for the engine load and vehicle speed?

- 1. The shifter valve*
- 2. The hydraulic control units*
- 3. The kick-down valve*
- 4. The speed-sensing valve*

Q2-25. The governor is normally mounted in which of the following locations on the transmission?

- 1. On the input shaft*
- 2. On the output shaft*
- 3. On the front pump*
- 4. On the rear pump*

Q2-26. Which of the following valves directs oil pressure to oppose the governor pressure, and thus delays upshifting?

- 1. The load control valve*
- 2. The kick-down valve*
- 3. The throttle valve*
- 4. The governor valve*

Q2-27. Which of the following components is NOT a common adjustment that can be made to an automatic transmission?

1. The hydraulic control unit
2. The throttle linkage
3. The control linkage
4. The bands

TRANSFER CASES

LEARNING OBJECTIVES: Recognize the purpose of transfer cases. Identify the components of the transfer case. Identify procedures for inspecting, checking, testing, and adjusting transfer cases.

Transfer cases are placed in the power trains of vehicles driven by all wheels. Their purpose is to provide the necessary offsets for additional propeller shaft connections to drive the wheels.

Some transfer cases contain an overrunning sprag unit (or units) on the front output shaft. (A sprag unit is a form of overrunning clutch; power can be transmitted through it in one direction but not in the other.)

On these units the transfer case is designed to drive the front axle slightly slower than the rear axle. During normal operation when both front and rear wheels turn at the same speed, only the rear wheels drive the vehicle. However, if the rear wheels should lose traction and begin to slip, they tend to turn faster than the front wheels. As this happens, the sprag unit automatically engages so that the front wheels also drive the vehicle. The sprag unit simply provides an automatic means of engaging the front wheels in drive whenever additional tractive effort is required. There are two types of spring unit transfers—a single and a double. Essentially, both types work in the same manner.

The first indication of trouble within a transfer case, as with other components of the power train, is usually noisy operation. If an operator reports trouble, make a visual inspection before removing the unit from the vehicle. Check for such things as oil level, oil leakage, and water in the oil.

Make sure the shift lever linkages are inspected. If the shift lever linkages are bent or improperly lubricated, it is hard to shift the transfer case. In some cases, this condition makes shifting impossible; make sure other possible troubles such as clutch slippage,

damaged propeller shaft, and damaged axles have been eliminated.

Worn or broken gears, worn bearings, and excessive end play in the shafts cause noise operation of the transfer case. When you have decided that the trouble is within the transfer case, remove the unit from the vehicle for repairs.

Make sure the transfer case is thoroughly cleaned before disassembly of the unit begins. When the unit is disassembled, clean each part with an approved cleaning solvent. Inspection of the individual parts should follow the same procedure as outlined for transmission. Avoid waste by reusing old parts that are in good condition.

If you are not thoroughly familiar with a particular make and model of transfer case, you should check the manufacturer's repair manual to ensure that proper adjustments and assembly procedures are followed.

Q2-28. During normal operation when both the front and rear wheels are turning at the same speed, the transfer case operates in what specific manner?

1. It applies torque to the front wheels only
2. It applies torque to the rear wheels only
3. It applies torque to both sets of wheels at the same time
4. It applies torque to neither the front nor the rear until there is a change of speed

Q2-29. What is the first indication that a transfer case is not operating properly?

1. The front wheels fail to turn
2. The rear wheels fail to turn
3. The vehicle will not move
4. The transfer case will produce unusual noises

PROPELLER SHAFT ASSEMBLIES

LEARNING OBJECTIVES: Identify components of propeller shaft assemblies. Identify procedures for repairing or removing and replacing propeller shaft assemblies.

The propeller shaft (drive shaft) assembly consists of a propeller shaft, a slip joint, and one or more universal joints (fig. 2-81). The propeller shaft is a driving shaft that transmits the power from the transmission to the differential. Propeller shafts may be solid or tubular. Tubular shafts are used when the

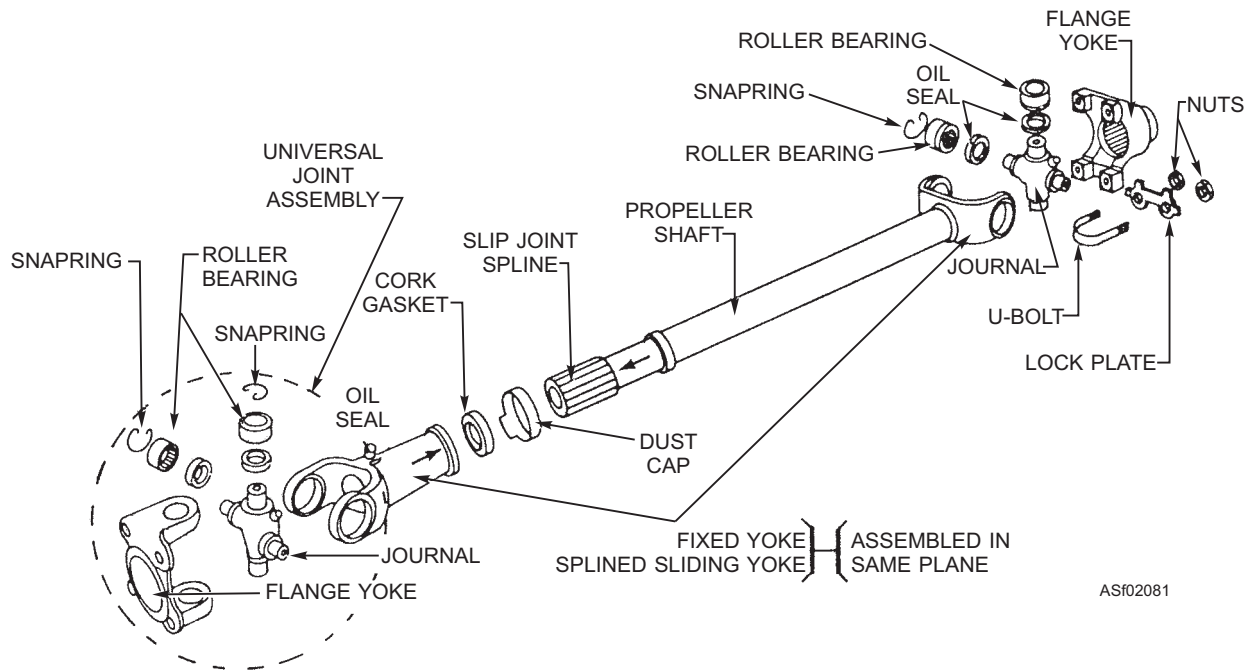

Figure 2-81.—Propeller shaft assembly.

transmission is some distance from the differential. Solid shafts are usually used on tow tractors because the shaft is very short.

The slip joint is necessary because the movement between the transmission and the differential requires that the propeller shaft be able to shorten or lengthen itself. On vehicles having rear springs, the differential moves up and down as the rear wheels move over uneven surfaces. This up and down movement lengthens and shortens the distance between the transmission and the differential. On vehicles such as tow tractors that have no rear springs, the slip joint is necessary because the distance between the transmission and the differential still increases and decreases when the vehicle moves over uneven surfaces. Vibration of the engine on its shock mounts and expansion and contraction also necessitate a slip joint.

Because the differential is situated below the level of the transmission, universal joints are necessary to permit the change of direction of drive. The usual type of slip joint consists of a splined shaft that fits into a splined sleeve, as shown in figure 2-81. The splints permit the continuing transmission of power as the sleeve moves back and forth on the shaft. A universal joint is essentially a double-hinged joint consisting of a Y-shaped yoke on the driven shaft, another Y-shaped yoke on the driving shaft, and a cross-shaped member called the spider. Figure 2-81 shows a common universal joint. Two of the four arms (trunnions) of the

spider fit into bearings in the end of the driving shaft yoke, and the other two arms (trunnions) are assembled in the end of the driven shaft yoke. When the two shafts are at an angle to each other, the bearings in the yokes permit the yokes to swing on the trunnions with each revolution. (Universal joints may have roller bearings around the trunnions.)

Slip joints and universal joints require little maintenance, except for those that need lubrication where fitted with grease fittings. Others may be factory packed with grease and not need lubrication. Repair is normally limited to removal and replacement of worn bearings, which are pressed out and replaced with new ones, as illustrated in figure 2-82.

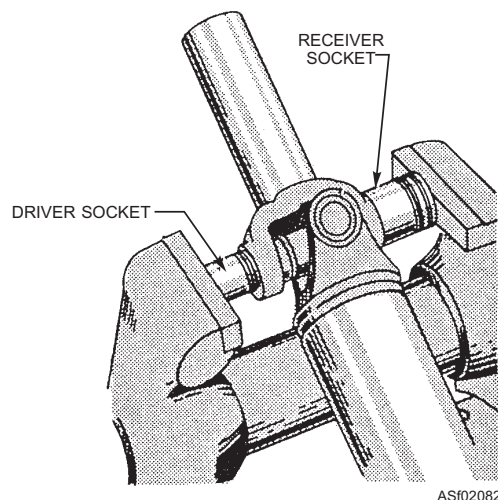

Figure 2-82.—Universal joint removal.

Q2-30. The purpose of the slip joint is to allow the propeller shaft to shorten or lengthen so that it can be used in several different types of SE?

1. True
2. False

Q2-31. What is the purpose of the universal joint?

1. It permits the change of direction of drive
2. It can be used in several different types of equipment
3. It allows the differential to apply power to one set of wheels at a time
4. It can shorten or lengthen depending on movement of the rear axle

DIFFERENTIALS

LEARNING OBJECTIVES: Identify the purpose of differentials. Identify procedures for inspecting, checking, and adjusting differentials. Identify troubleshooting procedures for differentials. Identify maintenance procedures for differentials.

The differential is connected to the propeller shaft by the final drive. The final drive consists of a pinion gear driven by the propeller shaft. The pinion turns a ring gear that is part of the differential. The function of the ring gear and pinion is to change the direction of the power transmitted through the propeller shaft by 90° in order to drive the axles. The ring gear and pinion also provide fixed reduction between the speed of the propeller shaft and the axles. The gear ratio is determined by dividing the number of teeth on the ring gear by the number of teeth on the pinion. Most aviation support equipments have bevel gears (fig. 2-83) in the final drive. Straight bevel gears are very noisy; therefore, spiral bevel gears are used on most equipment. The ring gear and pinion are housed in the differential housing and lubricated by gear oil.

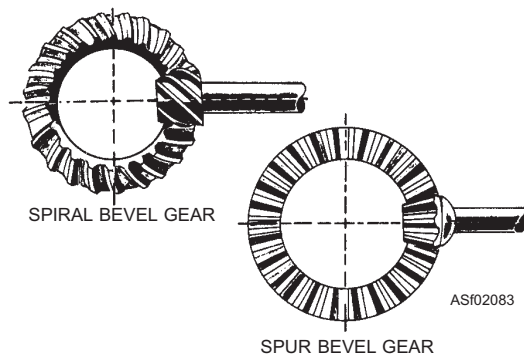

Figure 2-83.—Ring gear and pinion.

The purpose of the differential is to adjust for the difference in distance the driven wheels travel when the vehicle turns. For example, if a 90-degree turn was made on a 20-foot radius, the inner wheel would travel about 31 feet and the outer wheel would travel nearly 39 feet. The differential permits each axle to turn at a different rate and still be driven as a single unit.

CONVENTIONAL DIFFERENTIALS

The drive pinion, connected to the propeller shaft, rotates the drive ring gear and the differential case that is attached to it (fig. 2-84). When both wheels are rotating at the same speed, as they do on a smooth straight surface, the differential pinions do not rotate on their trunnions but serve to lock the drive ring gear and differential case with the differential side gears and axles, making them turn as one unit. In this case there is no relative motion between the drive ring gear and the axles, and the teeth of the differential pinions do not move over the teeth of the differential side gears.

When the vehicle turns, one wheel must turn faster than the other. The differential side gear driving the outside wheel through the axle turns faster than the side gear of the inside wheel. For the drive ring gear to remain meshed with the two differential side gears, each turning at different speeds, the differential pinions must turn on their trunnions. The amount by which the differential pinions cause the inside side gear to slow in the rate of turn is the amount by which they will cause the outside side gear to increase the rate of turn. The average speed of the two side gears is always equal to the speed of the drive ring gear. For

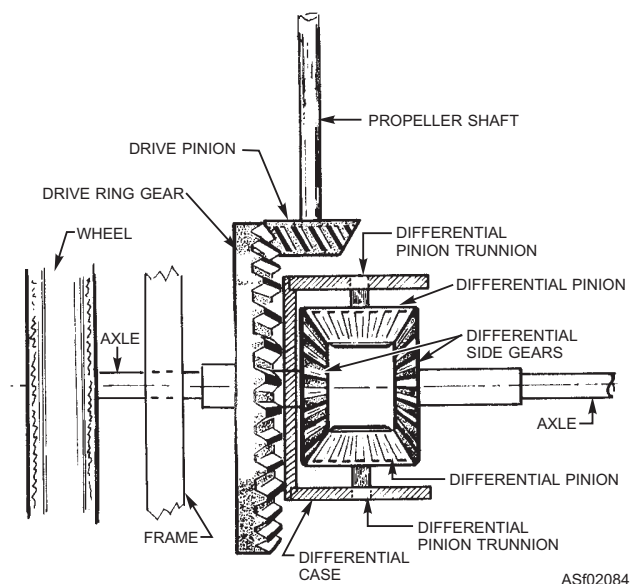

Figure 2-84.—Rear axles and differential.

example, if the drive ring gear makes four revolutions and the inner side gear, axle, and wheel make one revolution, the outside wheel will rotate seven times.

If one wheel spins free from traction on a vehicle using a conventional differential, the other wheel loses power because the differential pinions are revolving around the side gear of the stationary wheel and applying all the power to the spinning wheel. This result would be entirely unsatisfactory in towing tractors; therefore, a no-spin differential is employed.

NO-SPIN DIFFERENTIALS

To provide the means of improving tractive effort of the driving wheels when one wheel slips from loss of traction, the differential must prevent actual slippage and apply torque power to the driving wheels only to the extent that the wheels can use the torque without slipping. The no-spin differential (fig. 2-85) uses a pair of toothed clutches to do this. It does not contain side gears as does the conventional differential. Instead it contains a spider attached to the drive ring gear through four differential pinions turning on the spider trunnions, plus two driven clutch members with side teeth that are indexed by spring pressure with side teeth in the spider. Two side members are splined to the wheel axles and, in turn, are splined into the driven clutch members.

The center cam (fig. 2-86) in the spider is held in place by a snap ring that permits the center cam to rotate, but does not permit it to move laterally. When making a right turn, the right-driven clutch member remains fully engaged with the spider clutch teeth (fig. 2-87).

The spider clutch teeth (the driving teeth) drive the right (inside) wheel at drive ring gear speed. The left wheel (outside) covers a greater distance and must turn faster than the drive ring gear speed. The differential

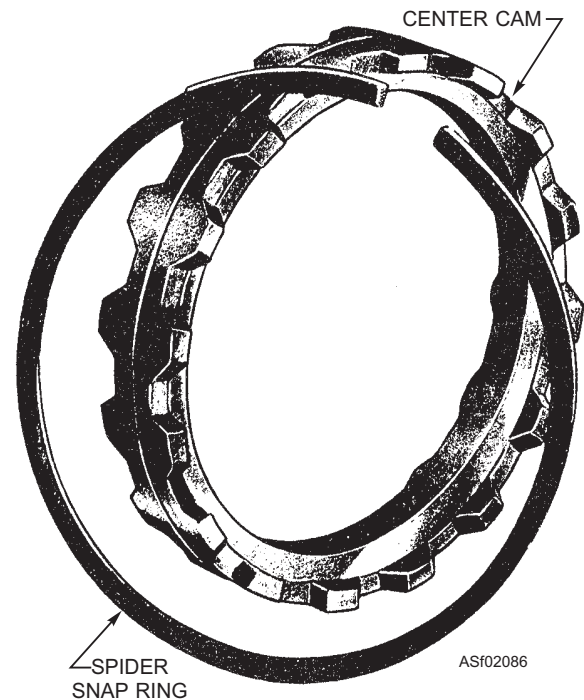

Figure 2-86.—Construction of center cam.

must permit this action. As the left wheel begins to turn faster, the left-driven clutch member also turns faster than the drive ring gear and spider speed. As the left-driven clutch member begins to turn faster, the cam lobes or ramps on its edge ride up on the cam lobes on the center cam. This action pushes the left-driven clutch member away from the spider so the clutch teeth disengage (fig. 2-88). As the crest of the ramp is passed, spring pressure forces the teeth of the driven clutch member back into full engagement with the teeth on the spider. This action is repeated as long as the left wheel turns more rapidly than the right wheel. Full drive is applied to the right wheel; no drive is applied to the left wheel. As soon as the vehicle completes the turn and the left wheel slows down to the right-wheel speed, driving power is applied equally to

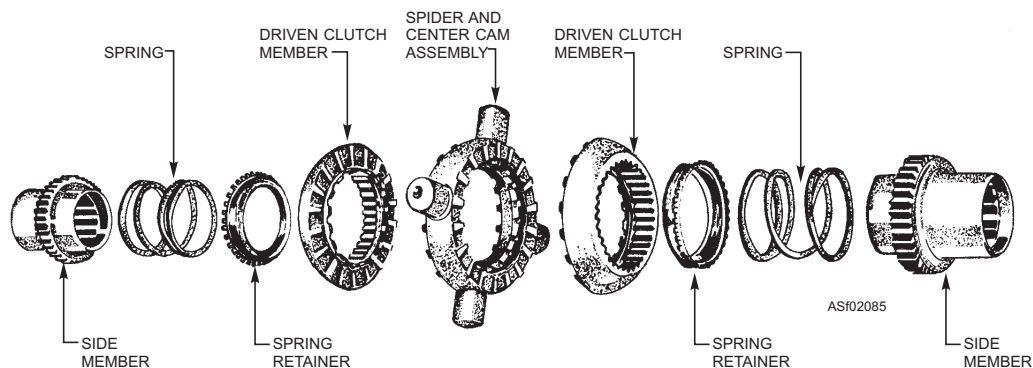

Figure 2-85.—No-spin differential disassembled.

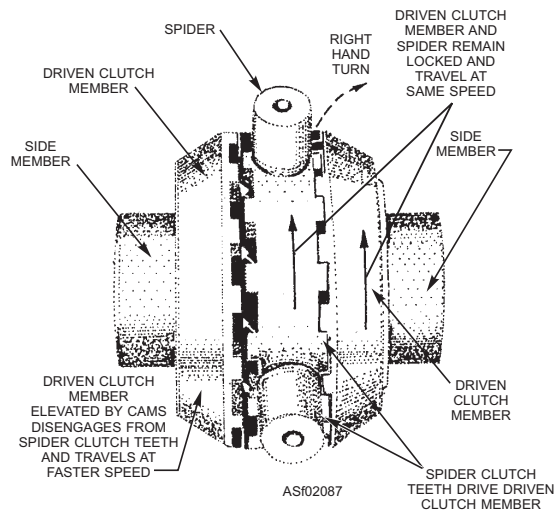

Figure 2-87.—Operation of a no-spin differential during a turn.

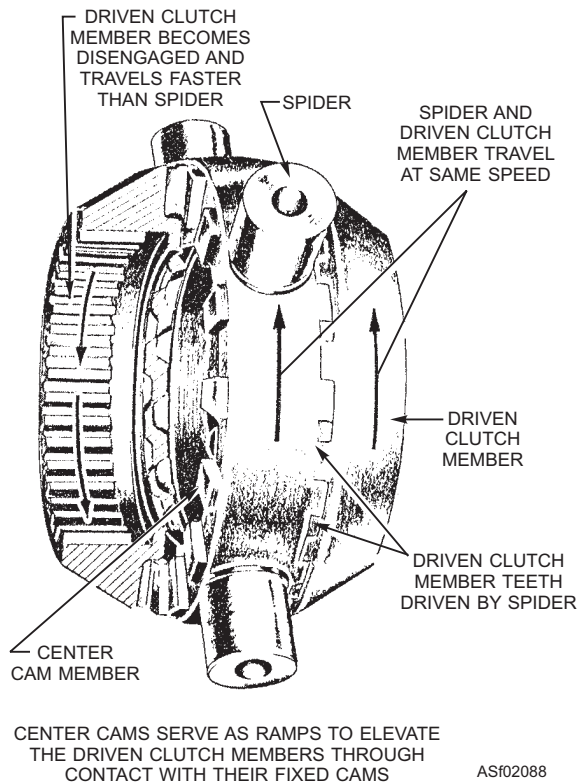

Figure 2-88.—Action of a center cam during a turn.

both. For a left turn, the action is similar except that full drive is applied to the left wheel; the right wheel turns more rapidly than the left wheel.

With the no-spin differential, one wheel cannot spin because of loss of traction, and thereby deprives the other wheel of its driving effort. For example, suppose that one wheel is on ice and the other wheel is on dry pavement. The wheel on ice is assumed to have

no traction. The wheel on ice cannot spin because wheel speed is governed by the speed of the wheel applying tractive effort. Therefore, the wheel on dry pavement will pull to the limit of its tractional resistance at the pavement.

MAINTENANCE

The gear oil in the differential should be periodically checked and brought to the proper level if needed. The area under the differential should be checked after the vehicle has been parked to determine that the gaskets in the differential housing are not leaking. When gaskets are leaking, you should drain the gear oil, support the housing, remove the bolts and old gasket, clean the surfaces, and install a new gasket. When operating the vehicle in cold weather, the manufacturer's specifications should be consulted to determine the differential gear oil to be used. It may be necessary to change gear oil with the seasons.

The first clue to existing trouble in a differential is usually a noise. Defective universal joints, rough gear wheel bearings, or tire noises may be improperly diagnosed as differential trouble. To properly determine the trouble, the source of the noise must be found, and the operating conditions under which the noise is most pronounced must be noted. A clue may be gained as to the cause of the trouble by noting whether the noise is a growl, a hum, or a knock; whether it is heard when the vehicle is operating on a straight road, or on turns only; and whether the noise is most noticeable when the engine is driving the vehicle or when it is coasting.

A humming noise in the differential usually means that the drive ring gear or drive pinion needs adjusting. An improperly adjusted ring gear or pinion prevents normal tooth contact between the gears and produces gear noise and wear. The humming noise gradually takes on a growling characteristic if the trouble is not corrected, and the ring gear and pinion eventually need replacing. The manufacturer's specifications and instructions should be consulted, studied, and followed for any adjustment.

Tire noises may be mistaken for differential noises. Tire noises vary according to the type of pavement the tires are on while differential noise will not. To determine whether the noise is caused by tire or differential, drive the vehicle over several types of pavement, and if the noise changes with the type of pavement, tires are the cause.

A noise that is present in the differential only when the vehicle is rounding a corner is usually caused by trouble in the differential case assembly. The differential pinion gears may be too tight on their trunnions, or the differential side gears may be tight. Damaged or worn gears can produce a noise when the vehicle turns. If bearings or gears are damaged, a knocking noise can result.

The quick engine change (QEC) program will guide you in the repair and replacement of differentials. Check the latest instructions for guidelines and level of authorized maintenance.

Q2-32. What is the purpose of a differential?

1. *To adjust for the difference in the distance the driven wheels travel when the vehicle turns*
2. *To adjust for the difference in torque to the driven wheels*
3. *To shorten or lengthen the propeller shaft*
4. *To connect the propeller shaft to the transmission*

Q2-33. What is the function of the side gears in a differential?

1. *They connect the planetary gear and the sun gear*
2. *They connect the shaft to the spline*
3. *They allow for one wheel to turn faster than the other when the vehicle is turning*
4. *They multiply torque on both drive wheels independently depending on load conditions*

Q2-34. Using the conventional differential, if one wheel spins free from traction, it will cause which of the following effects to the other wheel?

1. *Applies all the power to it*
2. *Causes it to lose power*
3. *Spins free from traction*
4. *Rotate at the same speed*

Q2-35. The no-spin differential uses what type of component to prevent the loss of traction?

1. *Overrunning clutches*
2. *Spline gears*
3. *Pinion gears*
4. *Toothed clutches*

DRIVE AXLE ASSEMBLIES

LEARNING OBJECTIVES: Identify the components of drive axle assemblies. Identify procedures for removing, replacing, and repairing drive axle assemblies.

The drive axle conveys the torque power from the differential to the wheel. It is made of steel and is solid in construction. Most aviation support equipment has full-floating drive axles (fig. 2-89). The wheel fits over the end of the axle housing, and the weight is carried by two roller bearings between the wheel and the axle housing. The outer end of the axle has a flange that bolts to the wheel. Thus, the axle goes through the axle housing and wheel and applies turning power to the outside of the wheel. The wheel is held on the axle housing by adjustment nuts (fig. 2-90). The wheel hub, roller bearings, and axle shaft are lubricated by the same gear oil that lubricates the differential. The axle can be removed by removing the flange bolts, breaking the flange seal, and pulling the axle from the housing. This can be done without removing the wheel. When replacing an axle, the proper size and thickness of the gasket should be used as specified in the manufacturer's instructions.

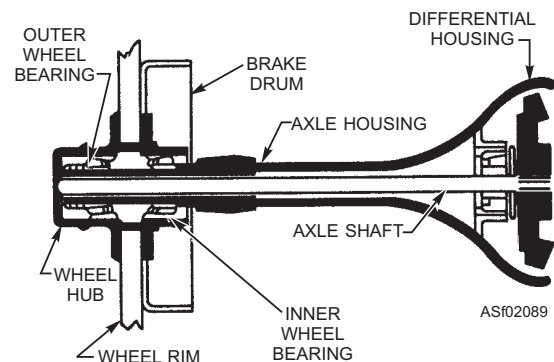

Figure 2-89.—Cross section of rear hub in full floating axle.

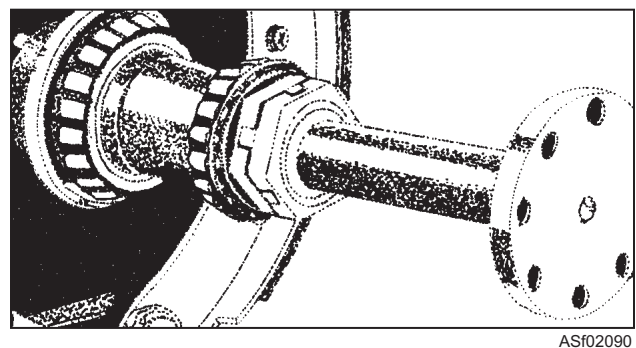

Figure 2-90.—Bearing mounting and adjustment nuts of full floating construction.

EXHAUST SYSTEMS

Some aviation support equipments, such as tow tractors, have rear axle planetary gears at the wheel end of the axle. These gears further reduce the power between the axle and the wheel. The axle has a gear on the outer end, which turns three planetary pinion gears; these turn an internal ring gear bolted to the wheel. This system is all lubricated by the same gear oil that lubricates the differential. For adjustment and servicing, consult the manufacturer's instructions.

SAFETY

While transmissions, propeller shaft assemblies, differentials, or rear axle assemblies are not usually dangerous to work on or service, all safety precautions related to mechanical work must be followed to prevent injury. These assemblies are heavy when removed as units, and the simple act of dropping one of them can cause a serious injury.

In addition to the usual safety precautions, it should be reemphasized that proper blocking of the vehicle being worked on is always a safe practice.

In addition, when one end of a vehicle is raised from the ground, a minimum of two safety stands should be used in place of the jack or lifting device that was used to raise the vehicle. It is never a safe practice to be under a vehicle when it is held off the ground only by lifting devices.

Q2-36. What types of drive axles are most commonly used in SE?

1. *Direct drive axles*
2. *Independent drive axles*
3. *Ridged drive axles*
4. *Full-floating drive axles*

LEARNING OBJECTIVES: Identify the purpose of exhaust systems. Identify the components of an exhaust system. Identify procedures for removing and repairing exhaust system components.

The purpose of the exhaust system is to channel harmful exhaust gasses to the rear of the vehicle. This system was developed to prevent the driver and passenger(s) from inhaling the harmful gasses and becoming ill. The exhaust system attaches from the exhaust side of the engine head, but it must be supported elsewhere as the system is made of light weight pipe and will not support itself. The most logical place to put the exhaust system is under the frame assembly where it can hang by hangers, called muffler hangers. They not only support the weight of the system but also help absorb the vibrations that could cause metal fatigue. Although the exhaust system is under the frame it normally does not hang below the lowest part of the chassis. This helps prevent it from being ripped off by flight deck arresting cables or road hazards on shore bases.

Most exhaust systems are made up several pieces of pipe and a muffler, as shown in figure 2-91. Some original equipment may be one-piece systems, but replacement parts are made up of several pieces.

To remove and replace the exhaust system, you should remove the section to be replaced by unbolting the attaching hardware and removing the items to be replaced with proper replacement items. Tighten the system hardware to the manufacturer's specifications.

NOTE: Always refer to the Maintenance Instruction Manual (MIM) when performing any maintenance on support equipment.

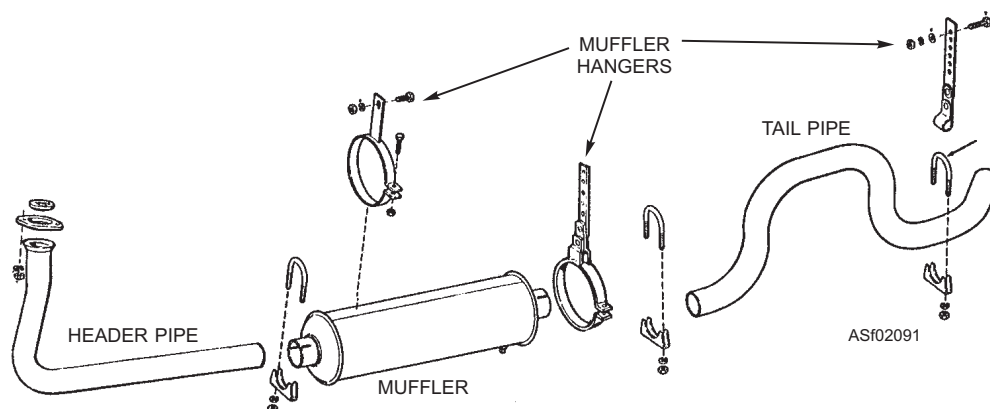

Figure 2-91.—Typical exhaust system.

Q2-37. What is the primary purpose for the automotive exhaust system?

1. It removes the gasses from the engine compartment and prevents them from reentering the engine intake
2. It creates a back pressure in the engine to increase fuel economy
3. It channels the gasses to the rear of the vehicle to prevent the driver from breathing harmful gasses
4. It allows for a means of connecting a muffler to reduce noise levels

TIRES AND WHEELS

LEARNING OBJECTIVES: Identify the components of tire and wheel assemblies. Identify the procedures for inspecting, checking, and adjusting tire and wheel assemblies. Identify troubleshooting procedures for wheel assemblies. Identify procedures for removing, repairing, and replacing tire and wheel assemblies.

As you have already learned, tires play a major role in braking, steering, and alignment. The *Support Equipment Tire and Wheel Assemblies* manual, NAVAIR 17-1-129, provides maintenance, inspection, repair and safety procedures for tire/wheel and bearing assemblies used on support equipment. This manual should be reviewed to ensure a complete understanding of these types of repair actions, as well as the technical manual for the model of equipment you are repairing.

This same manual is further intended to develop guidelines and procedures for training and certification of SE personnel as tire/wheel maintenance technicians. The most important rule for an AS on tire and wheel maintenance is that you are not authorized to perform any maintenance until you are tire and wheel certified in writing by your aircraft maintenance officer. Figure 2-92 is a sample certificate and figure 2-93 is a sample requirements list.

Program Manager Recommendation

Program Manager Signature _____ Date: _____

This is to certify _____ has successfully completed all established requirements for SE/AWSE tire/wheel tear down/build-up and is qualified to perform tire/wheel servicing/handling on:

_____ (Type Assembly)	_____ (MO Initials)	_____ (Type Assembly)	_____ (MO Initials)
_____ (Type Assembly)	_____ (MO Initials)	_____ (Type Assembly)	_____ (MO Initials)
_____ (Type Assembly)	_____ (MO Initials)	_____ (Type Assembly)	_____ (MO Initials)
_____ (Type Assembly)	_____ (MO Initials)	_____ (Type Assembly)	_____ (MO Initials)

MO Signature: _____ Date: _____

Original to:
Individual's Qualification/Certification Record

ASI02092

Figure 2-92.—Support Equipment tire/wheel maintenance certification.

Command: _____ W/C _____ Date: _____
 Name: _____ Rate/Rank: _____ SSN: _____
 W/C Supervisor Indoc Signature: _____ Date: _____

1. Required Reading: (applicable sections)	Trainee Initials	Supervisor Signature	Date
A. OPNAVINST 4790.2	_____	_____	_____
B. OPNAVINST 5100.19, VOL 1 Chapters A3, B5, B6, B12	_____	_____	_____
C. OPNAVINST 5100.23 Chapters 7, 10, 15, 19, 20	_____	_____	_____
D. NAVAIR 00-80T-96	_____	_____	_____
E. NAVAIR 01-1A-20, para 5-4 a/b	_____	_____	_____
F. NAVAIR 17-1-123	_____	_____	_____
G. NAVAIR 17-1-125	_____	_____	_____
H. NAVAIR 17-1-129	_____	_____	_____
I. NAVAIR 17-600-174-6-1	_____	_____	_____
J. NAVAIR 19-1-55	_____	_____	_____
K. Applicable MIMs/MRCs (List each applicable publication)	_____	_____	_____

2. Safety Films:	Trainee Initials	Supervisor Signature	Date
Servicing Multi-Piece Wheel Rims (OSHA A110) (Recommended)	_____	_____	_____
Servicing Single Piece Wheel Assemblies (OSHA A113) (Recommended)	_____	_____	_____
High Pressure Gases In Aviation (2479SDN) (Required)	_____	_____	_____
Aircraft Tire Maintenance (25784DN) (Required)	_____	_____	_____

NOTE: All required reading and viewing of video shall be accomplished prior to starting the tire/wheel maintenance OJT.

3. Completed course of instructions: Nitrogen Servicing Equipment
 Phase I Completion Date: _____ Phase II Completion Date: _____

4. OJT: A certified technician will sign off/date each area of OJT each time the individual performs a task under supervision (applicable for A through I).
 NOTE: Each OJT area requires a minimum of three tasks for each type assembly.

A. Bearings Removal/Cleaning/ Inspection/Handling/Lubrication/ Installation (if applicable)	Signature	Date
_____	_____	_____
_____	_____	_____
_____	_____	_____

1

A. Tear Down/Build-Up/Inflation of Solid Rim Assembly	_____	_____
_____	_____	_____
_____	_____	_____
C. Tear Down/Build-Up/Inflation of Split Rim Assembly	_____	_____
_____	_____	_____
_____	_____	_____
D. Tear Down/Build-Up/Inflation of Demountable Flange Assembly	_____	_____
_____	_____	_____
_____	_____	_____
E. Tear Down/Build-Up/Inflation of SD-2 Spotting Dolly (if applicable)	_____	_____
_____	_____	_____
_____	_____	_____
F. Use of Bend Breaker (if applicable)	_____	_____
_____	_____	_____
_____	_____	_____
G. Use of Inflation Gage	_____	_____
_____	_____	_____
_____	_____	_____
H. Operation of Nitrogen/Air Servicing Equipment/Remote Inflator Assembly	_____	_____
_____	_____	_____
_____	_____	_____
I. Documentation Procedures	_____	_____
_____	_____	_____
_____	_____	_____

5. Certification: A QAR, certified in tire and wheel maintenance, will sign each area only after the individual has demonstrated proficiency and awareness of all procedures and safety precautions.

A. Bearing Handling/Lubrication Procedures (if applicable)
 Signature: _____ Date: _____

B. Tear Down/Build-Up/Inflation of Solid Rim Assembly
 Signature: _____ Date: _____

2

C. Tear Down/Build-Up of Split Rim Assembly	Signature: _____	Date: _____
D. Tear Down/Build-Up/Inflation of Demountable Flange Assembly	Signature: _____	Date: _____
E. Tear Down/Build-Up Inflation of SD-2 Spotting Dolly Assembly (if applicable)	Signature: _____	Date: _____
F. Use of Bend Breaker (if applicable)	Signature: _____	Date: _____
G. Use of Inflation Gage	Signature: _____	Date: _____
H. Operation of Air Servicing Equipment/Remote Inflator Assembly	Signature: _____	Date: _____
I. Documentation Procedures	Signature: _____	Date: _____

WRITTEN TEST SCORE (Minimum 90 percent): _____

QAR Signature: _____ Date: _____

3

ASf02093

Figure 2-93.—Support equipment tire/wheel maintenance requirements.

WHEEL RIMS

The three types of rims most commonly used on SE are the solid rims, split rims, and demountable flange rims.

Solid Rims

Solid rims are made in one piece and are permanently fastened to the wheel hub (fig. 2-94). They feature a well in the center that permits mounting and demounting of the tire. This type of rim is often referred to as a drop center rim, and is generally used on smaller vehicles and light trucks.

Split Rims

Split rims consist of two, usually identical, halves secured together by tie bolts. They are usually mounted on handling equipment, small trailers, and front wheel assemblies of towing tractors. When assembling split rim wheels, you must ensure that steel and aluminum halves are not mixed. Mixing different types of wheel halves may cause cracks and wheel failure.

Demountable Flange Rims

The demountable flange rim consists of two parts: the rim base and the demountable flange. The demountable flange (split ring) holds the tire by interlocking with the rim base when the tire is inflated.

This rim is used on rear axles of towing tractors and similar heavy duty vehicles. Rims are mounted with the demountable flange outboard on single wheel installations, and facing each other on dual wheel installations.

TIRES

The types of tires most commonly used on SE are bias ply, bias belted, radial, tubeless, and solid rubber tires.

Bias Ply

In bias ply tires, tire cords are arranged in two or more (even number) plies, depending on the strength desired in the finished tire. The cords, or plies, cross the tire circumference at an angle, usually 30 to 40 degrees. This design provides rigidity in both sidewall and tread. A disadvantage is that bias ply tires squirm more and tend to run hotter than belted bias or radial tires.

Bias Belted

Constructed similarly to bias ply tires, belted tires will have an additional two or more layers of fabric (belts) under the tread. The cords in the belt also run at an angle, about 25 degrees to the circumference. This construction provides the sidewall stiffness of the bias ply with increased strength and stiffness in the tread.

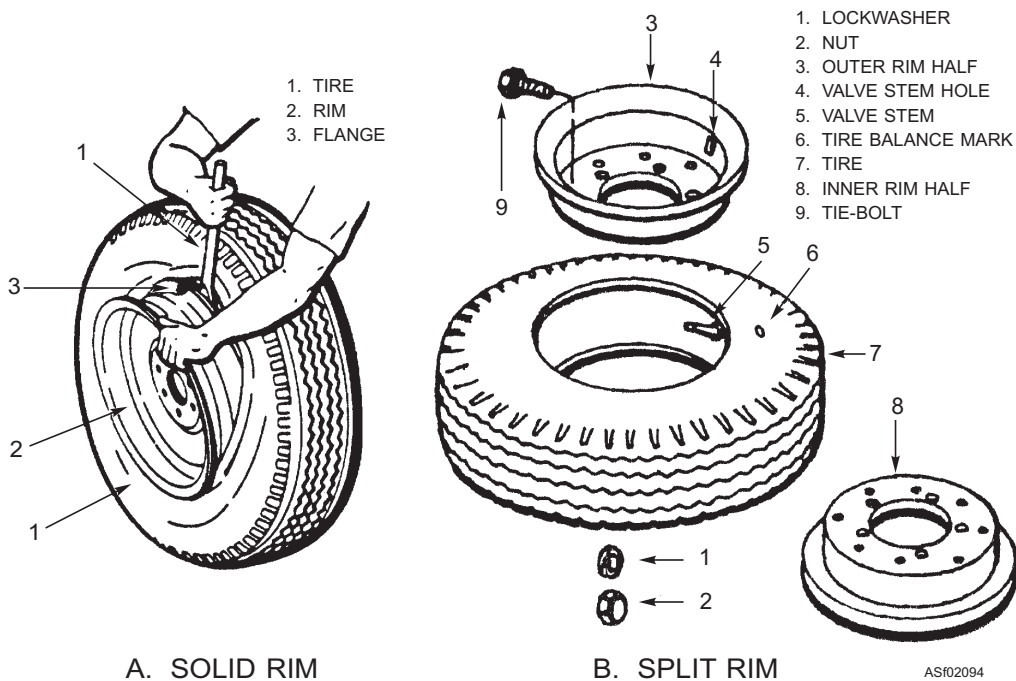

Figure 2-94.—Solid and split rims.

The bias belted tires squirm less, run cooler, and give better mileage than the bias tire.

Radial

Radial tires are constructed with one to three plies of the body cords running at right angles to the circumference. Over this radial section is added a belt, or belts, of fabric or steel. The design provides a tire with flexible sidewalls but great stiffness and strength in the tread area. It has minimum squirm, runs cool, and provides long wear.

Tubeless Tires

Tubeless tires may be bias ply, bias belted, or radial. In addition, they have a thin rubber lining, and the bead area is grooved to form an airtight seal with the rim.

Solid Rubber Tires

Solid rubber tires are used primarily on slow moving, heavy loading equipment. They provide far less cushioning than pneumatic tires but give loading capacity far greater than comparable sized pneumatic tires.

WHEEL AND TIRE MAINTENANCE

The types of wheel assemblies found on support equipment are split rim, demountable flange, and solid rim (automotive) types. Of the three types of wheel assemblies, the demountable flange possesses the highest potential for explosive separation.

The destructive potential of air, or nitrogen, under pressure is tremendous. As an example of the explosive force produced, a 10.00 x 20 tire inflated at 105 psig creates in excess of 40,000 pounds of pressure against the rim flange. In a controlled test, this force accelerated the locking to 130 mph, and raised a 215-pound dummy 10 feet upward from a wheel resting horizontally on the deck. This explosive potential requires that all inflated, or partially inflated, tires be handled with the same care and precautions given live ordnance.

Nondestructive Inspection

A nondestructive test/inspection (NDI) of split rim (steel) wheels and tie-bolts are required by applicable periodic maintenance requirements cards (MRCs). (Example, front wheel assembly, P/N

HA-1321, A/S32A-31A tow tractor.) Rims requiring NDI and meeting visual inspection are paint stripped and subjected to magnetic particle or liquid penetrant inspection. Personnel performing NDI inspection must hold current certification according to requirements of OPNAVINST 4790.2 for MIL-STD-6866 and/or MIL-STD-1949 inspection methods.

Removing and Replacing Tires

The following procedures involve removing a wheel from a vehicle, removing the tire from the rim, putting the tire back on the rim, reinflating the tire, and putting the wheel back on the vehicle.

Use a “deflated tire flag” to show that a tire has been deflated and the valve core removed. Maintenance should never be conducted on a wheel/tire assembly where a deflated tire flag is not installed. The flag tells you that the tire is safe. Deflated tire flags are usually made locally, and they are made so that the pin extends at least 1/4 inch beyond the open end of the valve cap, with the cap shouldered against the pin.

WARNING

Short deflated tire flag pins (less than 3/4 inch) may enable the flag to be screwed on the valve stem with the valve core still installed. Always check to be sure that the core has been removed.

REMOVING WHEEL ASSEMBLIES.—Use the following steps for removing a wheel from a vehicle:

1. Chock both wheels at the end opposite the end being jacked.
2. Jack the vehicle and place jack stands under the frame or axle, as required by the technical manual. Lower the vehicle to the jack stands. If aboard ship, install tie-down chains.
3. Deflate the tire to be removed, remove the valve core, and install a deflated tire flag (fig. 2-95). If the valve stem is equipped with a valve extension, remove the extension valve core and extension first. Wheels being removed to facilitate other maintenance need only be deflated to storage pressure, which is one-half the service pressure or 15 psig, whichever is less.

NOTE: On dual wheel installations, the wheel not being serviced should be deflated to 15 psig prior to loosening any wheel clamps or mounting bolts.

4. Remove the wheel clamps using a crisscross pattern.
5. Remove the wheel.

DEMOUNTING A TIRE.—The use of power-operated equipment, when available, for demounting tires is recommended. When using power-operated equipment, follow the manufacturer's operating instructions carefully. When demounting is to be done by hand, proceed as follows:

1. Loosen both tire beads from the rim flanges by inserting a bead breaking iron between the rim flange and the tire bead (fig. 2-95). Work progressively around the rim, rotating the bead breaking iron down and forcing the bead completely into the center well area. Turn the wheel over and repeat the procedure.

NOTE: Ensure that the tire is fully deflated before dislodging the tire beads. Use care in dislodging the tire beads to avoid damaging the bead seats. If the tire bead requires excessive force to break free, apply tire lubricant to the bead area.

2. With the demountable flange side facing up, insert the lock ring tire iron, curved side up, into prying notch (fig. 2-95). With the iron, pry the flange partly out of the rim. Insert a flat tire iron adjacent to the lock ring tire iron and work both irons progressively around the rim until the flange is completely removed.

3. If the tire has a tube, push the valve stem through the hole in the rim. Shift the tire and tube on the rim to keep the stem away from the edges of the valve hole.

4. Hold the upper tire bead down into the well area of the rim (fig. 2-95). On the opposite side of the rim, insert a flat tire iron between the upper bead and the rim. Pull the tire iron down, lifting the tire bead partly off the rim. Use a second tire iron to work progressively around the rim, completely removing the upper tire bead.

5. Stand the wheel upright. Push down on the rim so the inner tire bead is positioned in the well area (fig. 2-95). Insert a flat tire iron between the inner tire bead and the rim. Pry the tire free of the rim.

6. If the tire has a tube, remove the flap and tube from the tire (fig. 2-95). Inspect all parts for wear, deterioration, or other defects. If the rim is to be reused, it should be cleaned, coated, and finished according to maintenance instructions.

NOTE: To prevent damaging wheel components, areas for servicing tires and wheels normally have rubber matting on the deck.

MOUNTING A TIRE.—Use the following procedure to mount a tire on a rim:

1. If you are installing a tube in the tire, dust it with talcum powder ZZ-T-416 to assist in assembly and to reduce chafing. Insert the tube and flap into the tire (fig. 2-95). Align the valve stem with the balance mark on the side of the tire. Inflate the tube slightly to hold the tube and flap in place and to prevent it from becoming wrinkled or pinched.

2. Apply rubber lubricant to both tire beads and the rim flange area.

3. Place the rim on rubber matting with the demounting flange side up (fig. 2-95). Place the tire on the rim, and align the valve stem with the valve hole. If necessary to force the tire bead down into the well area, tap it in using a rubber hammer. Be careful not to damage the tire bead seat. Use a flat tire iron to force the lower tire bead completely into the rim well area. Guide the valve stem through the valve hole in the rim.

4. Use a flat tire iron to pry the upper tire bead over the edge of the rim (fig. 2-95). Force the bead completely into the well area of the rim.

5. Place the end of the demountable flange, without the prying notch, into the gutter of the rim (fig. 2-95). Insert the tire iron into the notch of the flange and under the gutter of the rim. Pry the flange over the edge of the rim. Hold the flange, and work progressively around the rim until the flange is completely down into the gutter. Shift the tire and the tube on the rim to center the valve stem in the rim valve hole.

6. Inspect the wheel to insure that the flange is fully seated under the rim gutter (fig. 2-95). The opening between the flange ends should be 3/32 inch to 5/16 inch (1/4 inch is optimum).

WARNING

Because of its design, the demountable flange rim is potentially the most dangerous of all the rims handled in the aviation support equipment community. Personnel servicing this rim/wheel assembly must adhere to all safety precautions, listed or inferred, in NAVAIR 17-1-129 and other applicable technical manuals.

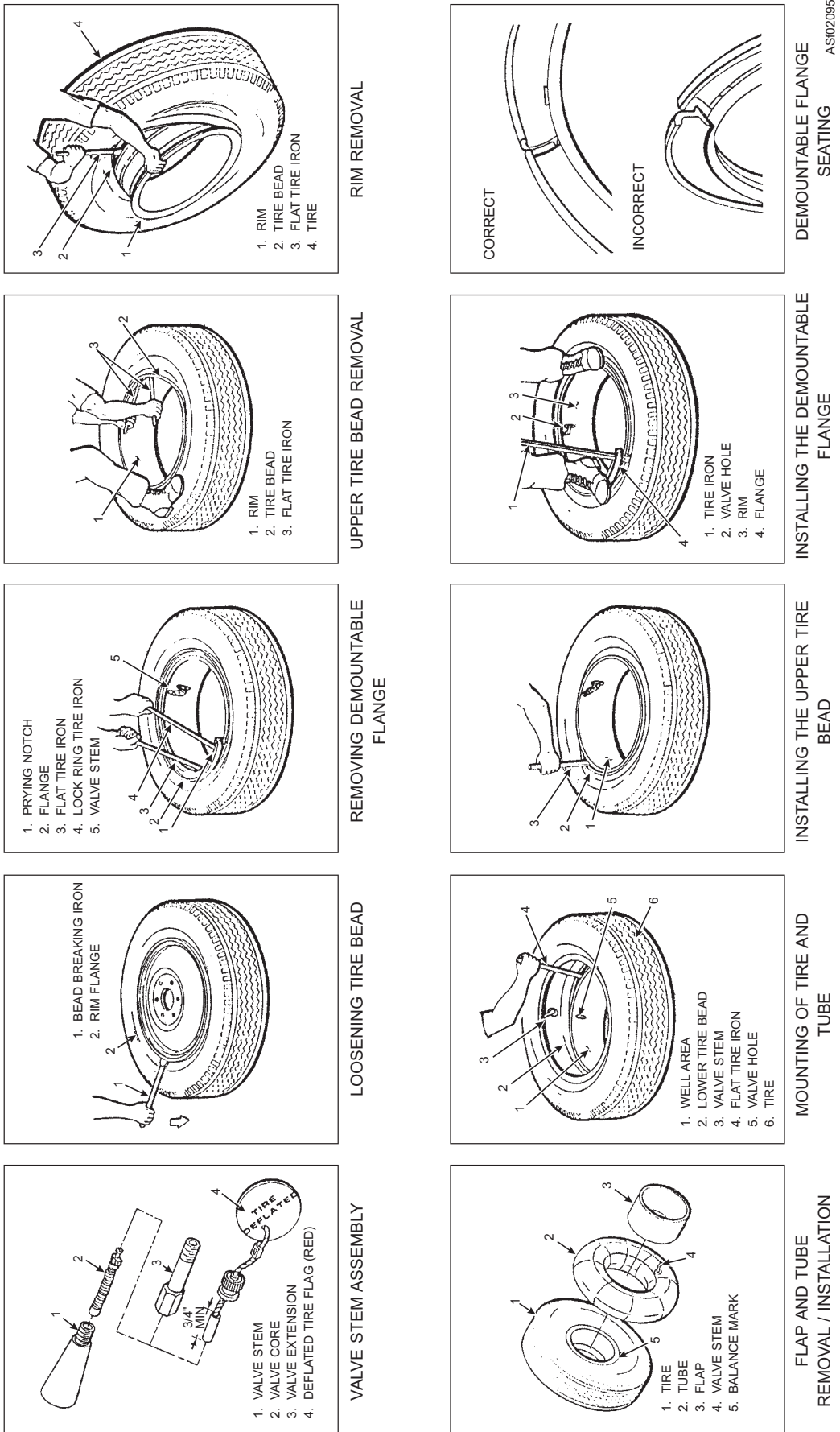

Figure 2-95.—Demountable flange teardown and buildup.

INFLATING A TIRE AFTER MOUNTING.—

Inflating a support equipment tire involves the use of two very specific pieces of equipment. These two pieces of equipment are a tire inflator assembly and an inflation safety cage.

Tire Inflator Assembly Kits.—A tire inflator assembly kit, commonly called an inflator, is a tool for inflating aircraft and support tires (fig. 2-96). The kit comes with all of the fittings and gauges required to service vehicle and aircraft wheel assemblies. Because of the numerous types and sizes of support equipment tires used, tire shops must have an assortment of the kits to cover a variety of tire pressures. Note in figure 2-96 that the two gauging elements in this kit cover the ranges of 10 to 150 psig and 50 to 600 psig.

Always use the proper kit for the job, which is the one whose relief pressure valve is set closest to, but greater than, the service pressure of the tire.

Tire Inflation Safety Cage.—Tires/rim assemblies sometimes explode violently during initial inflation after being mounted. Normally, this is the result of defects in the materials or improper assembly. A tire inflation safety cage is a device for containing a tire during inflation (fig. 2-97). Current regulations require that after mounting, any tire must be placed in a safety cage before it is inflated to its service pressure. The sole purpose of the safety cage is to protect you.

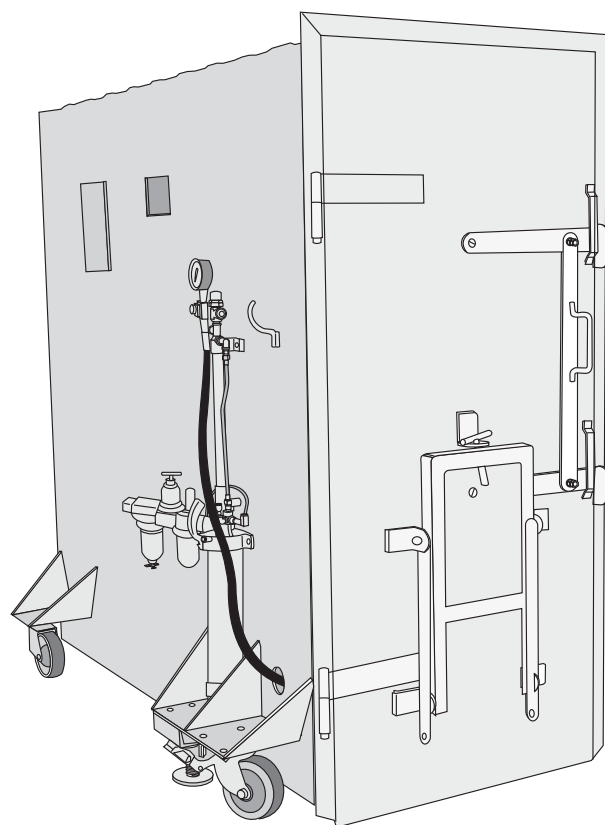

ASf02097

Figure 2-97.—Safety cage for inflation of tires.

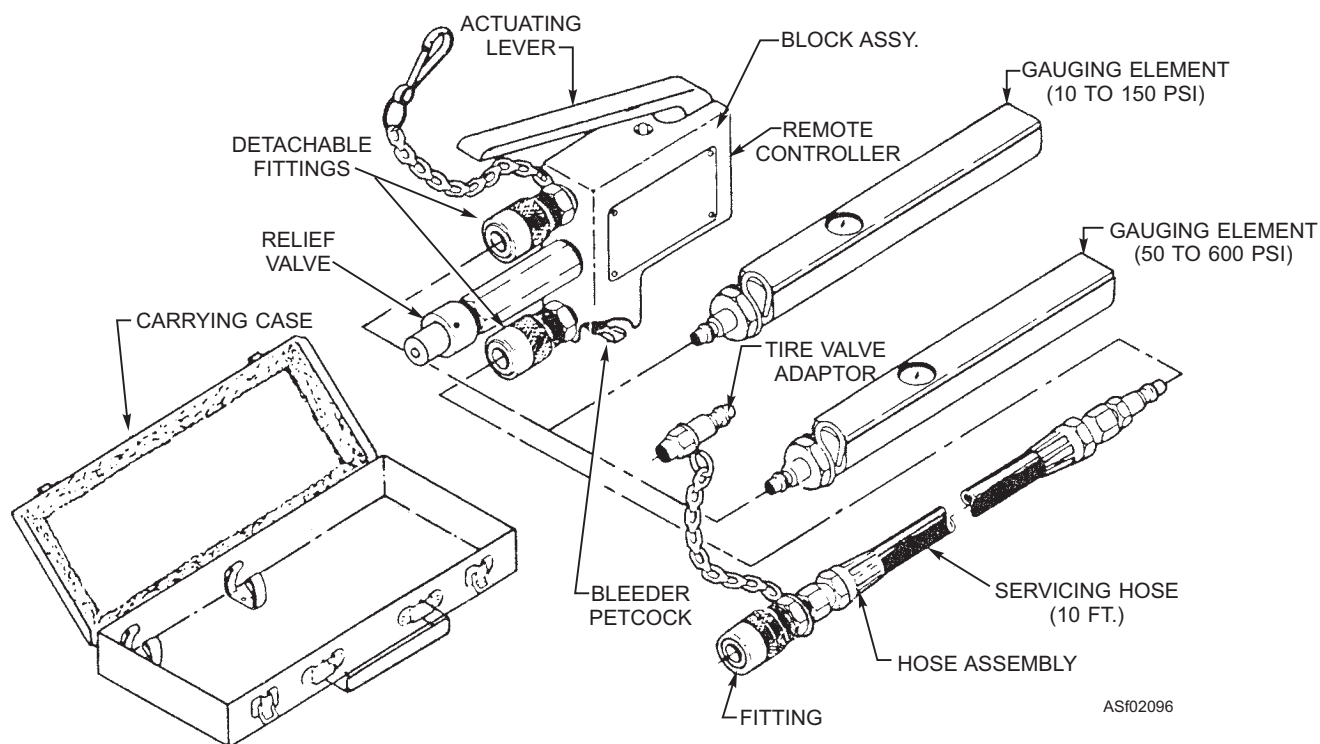

ASf02096

Figure 2-96.—Tire inflator assembly kit.

WARNING

Never repair or adjust tires alone. And, under no circumstances should you reach into, or enter, the tire inflating cage for the purpose of servicing or adjusting equipment, except in the presence of someone capable of rendering aid.

While an inflation cage is in operation, do not allow any person to rest or lean against the cage. Do not place any equipment on, or lean any equipment against, the cage.

Inflating the Tire.—The unintended explosive separation of tire and rim components is the primary cause of accidents during tire/wheel servicing. For this reason, servicing should only be conducted by fully certified personnel, or personnel under the direct supervision of certified personnel.

Use the following steps to inflate a tire after mounting it on a rim:

1. Remove the valve core (or deflated tire flag), and attach the tire valve adapter to the valve stem (fig. 2-95).
2. Attach the servicing hose fitting to the valve adapter.
3. Place the wheel in the inflation safety cage (fig. 2-96). Close and secure the door of the safety cage.
4. Select the proper gauging element from the tire inflator assembly, and attach it to the remote controller.
5. Connect the servicing hose to the remote controller, and connect the remote controller to the shop air supply.
6. Inflate the tire to a maximum of 10 psig, and allow it to fully deflate. This should cause the tube to center itself in the tire, and the tire bead should seat onto the bead seat. Then, inflate the tire with just enough pressure to seat both tire beads against the rim flanges. The beads should seat before reaching the service pressure for the tire.

CAUTION

Never exceed tire service pressure while seating the beads. The beads may strike the flange with enough force to break, jump the flange, or otherwise damage the tire.

7. Continue inflating until the service pressure for the tire is reached. Then, leave the tire in the safety cage for 10 minutes. After 10 minutes, recheck the pressure. If no loss is detected, reduce the pressure in the tire to 50 percent of service pressure, or 15 psig, whichever is the lesser.

8. Remove the wheel from the inflation cage. Remove the servicing hose fitting and valve adapter, and install a valve cap, finger tight.

The wheel is now ready to be placed in storage or mounted on a vehicle.

If the Beads Fail to Seat During Inflation.—Occasionally beads will fail to seat due to friction between the bead and the rim. If the beads will not seat, deflate the tire, remove it from the cage, and apply fresh tire lubricant. Return the tire to the cage and repeat the inflation procedure.

WARNING

Inflated tires should be inspected for proper flange and tire bead seating while still contained within the inflation cage. However, do not try to correct the seating of tire beads or rim flange by hammering, striking, or otherwise forcing the components while the tire is pressurized.

If a Significant Pressure Loss is Noted After Inflating the Tire.—If a significant pressure loss is noted during the 10 minute wait following inflation of a tire, use the following steps to correct the problem:

1. Reduce pressure 50 percent of service pressure, or 15 psig, whichever is the lesser.
2. Remove the wheel from the inflation cage.
3. Remove the servicing hose and valve adapter.
4. Determine the cause of the leak and make repairs. Some common causes are:
 - A defective or incorrect valve core
 - A loose valve stem or damaged seal (tubeless)
 - A defective rim/tire seal area (tubeless)
 - A defective tire inner liner (tubeless)
 - A puncture
 - A defective or cut valve stem (tube)

- A damaged or deteriorated inner tube

After the cause of the leak is corrected, inflate the tire.

INSTALLING THE WHEEL ON THE VEHICLE.—When wheels are to be used on dual installations, they should be matched in size and tread wear. Improperly matched tires cause rapid, uneven wear, and may also cause transfer case and differential failures.

If dual tires are used in a situation where permissible differences in measurement are allowed, the larger tire should be mounted outboard. Table 2-2 lists some instances where differences in measurement are allowed.

Table 2-2.—Tolerances in Matching Dual Tires

Outside Diameter of Tire	Permissible Difference	
	Diameter	Circumference
Under 30 inches	1/4 inch	3/4 inch
From 30 to 40 inches	3/8 inch	1-1/8 inch
From 40 to 50 inches	1/2 inch	1-1/2 inch
Over 50 inches	3/4 inch	1-3/4 inch

Use the following steps for installing a wheel on a vehicle:

1. Ensure that the vehicle is firmly supported on jack stands and chocked. (For our discussion, assume that you are aboard ship, and tie-down chains are required.)
2. Place the wheel on the vehicle.
 - Install single wheels with the demountable flange outboard.
 - For dual wheel assemblies, mount the inner wheel with the demountable flange facing outboard. Install a spacer and then the outer wheel. For the outer wheel, the demountable flange faces inboard.
3. Install the wheel bolts/clips. Use a crisscross pattern, and apply the correct amount of torque. When torque values are not listed in the technical manual or MRC, use the values listed in table 2-3.

NOTE: Threads should not be oiled, as the torque values listed are derived with oil-free threads.

4. Install the tire valve adapter to the valve stem, and connect the fitting to the adapter.

Table 2-3.—Torque Ranges by Bolt Size

FINE THREAD SERIES	
Bolt Size	Torque (lbs in.)
5/16 - 24	100 - 140
3/8 - 24	160 - 190
7/16 - 20	450 - 500
1/2 - 20	480 - 690
9/16 - 18	800 - 1000
5/8 - 18	1100 - 1300

5. Attach the gauge to the remote controller. Ensure that the relief pressure valve setting of the remote controller is no higher than necessary.
6. Connect the servicing hose and shop air to the remote controller.
7. Inflate the tire to the prescribed service pressure. Use short bursts to allow frequent pressure checks.
8. Remove the fitting and valve adapter, and install the valve cap, finger tight.
9. Loosen the tie-downs, and jack the vehicle enough to remove the jack stands. Lower the vehicle, remove the jack, and retighten the tie-downs.

WARNING

When inflating a tire outside of a safety cage, ensure that all personnel are clear of the rim/tire trajectory area.

NOTE: We elected to base our discussion here on the demountable flange rim because it is potentially the most dangerous to work with. However, the procedures for working with solid and split rims is very similar. Consult NAVAIR 17-1-129 and other applicable technical manuals for procedures for working with these types of rims.

Repairing Wheels by Welding

Wheels should be repaired by welding only when new wheels are not available. Such repairs are limited to one weld of a crack that is no longer than 1 inch, or two welds of cracks that are no longer than 1/2 inch. Further, no weld can be within 1 inch of any bolt hole.

Wheels repaired by welding must be NDI inspected, and must be replaced as soon as possible.

SAFETY REVIEW

Here are a few safety precautions to remember when working with support equipment tire and wheel assemblies:

Always place wheels in an inflation cage or an OSHA approved equivalent restraining device for initial inflation. Wheel assemblies sometimes explode violently during initial inflation due to defects or improper assembly.

For aircraft tires used on support equipment, such as the spotting dolly, only an approved aircraft tire inflation cage should be used. (Aircraft tires are typically inflated to 200 pounds, or more.)

On dual wheel installations, the wheel not being serviced should be deflated to 15 psig prior to loosening any wheel clamps.

Ensure that a tire is fully deflated before dislodging the tire beads.

Never exceed tire service pressure to seat beads. Beads may strike flanges with enough force to break, jump the flange, or otherwise damage the tire.

For vehicles with disc brakes, wheels should be installed using a torque wrench only. Impact wrenches may distort the brake disc when used to tighten lug nuts/bolts.

*Q2-38. Which of the following types of rims are **NOT** used on SE?*

1. Split rims
2. Open-faced rims
3. Solid rims
4. Demountable flange rims

Q2-39. In what direction should the lock rings of the demountable flange rim be installed on the hub of a tow tractor that has more than one wheel per side?

1. They should be installed so that they are facing each other
2. They should be installed so that they are facing away from each other
3. They should be installed so that both rings are facing outboard
4. They should be installed so that both rings are facing inboard

Q2-40. Which of the following components must be installed on a tire prior to removing it from the item of SE?

1. The safety tag
2. The demountable flange
3. The valve stem
4. The deflated tire flag

Q2-41. What is the minimum required length of a deflation tire flag pin?

1. 1.0 in.
2. 1/4 in.
3. 1/2 in.
4. 3/4 in.

Q2-42. What are the two very specific pieces of equipment that are required to inflate a tire after it has been assembled?

1. High pressure air and a tire inflator assembly
2. An inflation cage and a tire inflator assembly
3. An inflation cage and a pressure gauge
4. A tire inflator assembly and nitrogen cart

Q2-43. There are procedures you must follow if there is significant tire pressure loss after how many minutes?

1. 10 min
2. 20 min
3. 30 min
4. 40 min

Q2-44. When it becomes necessary to weld a wheel assembly, repairs are limited to which of the following specifications?

1. Limited to 1 weld, no longer than 1/2 inch
2. Limited to 2 welds, no longer than 1 inch each
3. Limited to 1 weld, no longer than 1 inch
4. Limited to 2 welds, no longer than 1/3 inch each

CHAPTER 3

PRINCIPLES OF INTERNAL COMBUSTION ENGINES

INTRODUCTION

As an Aviation Support Equipment Technician, you will be concerned with repairing and replacing worn or broken parts, making various adjustments to vehicles and equipment, and seeing that vehicles and equipment are properly serviced and regularly inspected. To perform these duties intelligently, it is important that you fully understand the principles of internal combustion engine operation and the function of the various components that make up the engine. This knowledge will make your job of diagnosing trouble and making corrections much easier.

This chapter discusses basic principles of engine operation and briefly explains some of the related terms. You will hear many of these terms used around the shop, and you will see them in maintenance and repair manuals.

COMBUSTION ENGINES

LEARNING OBJECTIVE: Define the term “combustion.” Define the main principles governing the operation of gasoline and diesel engines. Identify the four basic engine strokes.

Combustion is the act or process of burning. An internal or external combustion engine is defined simply as a machine that converts this heat energy to mechanical energy. To fulfill this purpose, the engine may take one of several forms. In the internal combustion engine, combustion takes place within a

cylinder inside the engine and is directly responsible for forcing the piston to move down. In external combustion engines, such as steam engines, combustion takes place outside the engine. Figure 3-1 shows, in simplified form, external and internal combustion engines.

The external combustion engine requires a boiler to which heat is applied. This combustion causes water to boil to produce steam. The steam passes into the engine cylinder under pressure and forces the piston to move downward.

The transformation of heat energy to mechanical energy by the engine is based on a fundamental law of physics that states “gas will expand when heated.” The law also states that “when a gas is compressed, the temperature of the gas will increase.” If the gas is confined with no outlet for expansion, the pressure of the gas will be increased when heat is applied. In the internal combustion engine, the burning of a fuel within a closed cylinder results in an expansion of gases. This expansion creates pressure on top of a piston, causing it to move downward. In an internal combustion engine, the piston moves up and down within a cylinder.

This up-and-down motion is known as reciprocating motion. This reciprocating motion (straight line motion) must be changed to rotary motion (turning motion) in order to turn the wheels of a vehicle. A crankshaft and a connecting rod change this reciprocating motion to rotary motion.

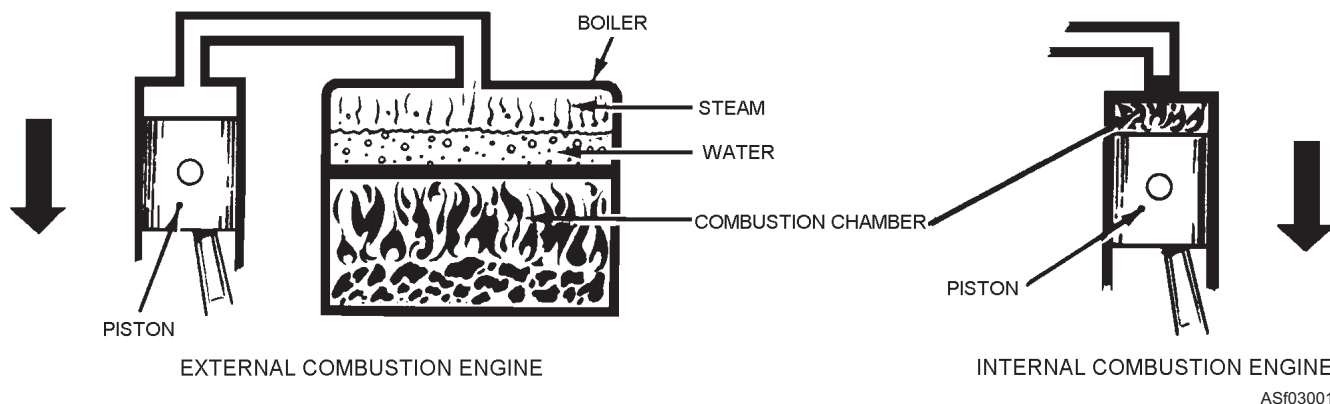

Figure 3-1.—Simple external and internal combustion engines.

All internal combustion engines, whether gasoline or diesel, are basically the same. We can best demonstrate this by saying they all rely on three things—fuel, air, and ignition. Fuel contains potential energy for operating the engine. Air contains the oxygen necessary for combustion, and ignition starts combustion. All are fundamental, and the engine will not operate without all of them. Any discussion of engines must be based on these three factors and the steps and mechanisms involved in delivering them to the combustion chamber at the proper time.

DEVELOPMENT OF POWER

The power of the internal combustion engine comes from burning a mixture of fuel and air in a small, enclosed space. When this mixture burns, it expands greatly, and the push or pressure created is used to move the piston, thereby rotating the crankshaft. This movement is eventually sent back to the wheels to drive the vehicle.

Since similar action occurs in all cylinders of an engine, let's use one cylinder to describe the steps in the development of power. The 1-cylinder engine consists of four basic parts, as shown in figure 3-2.

First, we must have a cylinder that is closed at one end; this cylinder is similar to a tall metal can and is stationary within the engine block. Inside this cylinder is the piston, a movable metal plug, which fits snugly into the cylinder, but can still slide up and down easily. This movement of the piston is caused by the burning of fuel in the cylinder, which results in the production of reciprocating motion.

You have already learned that the up-and-down movement of the piston is called "reciprocating motion." This motion must be changed to rotary motion. This change is accomplished by a throw on the crankshaft and a connecting rod, which connects the piston and the crankshaft throw.

The throw is an offset section of the crankshaft, which scribes a circle as the shaft rotates. The top end of the connecting rod is connected to the piston; therefore, it must go up and down. The lower end of the connecting rod is attached to the crankshaft. The lower end of the connecting rod also moves up and down but, because it is attached to the crankshaft, it must also move in a circle.

When the piston of the engine slides downward because of the pressure of the expanding gases in the cylinder, the upper end of the connecting rod moves

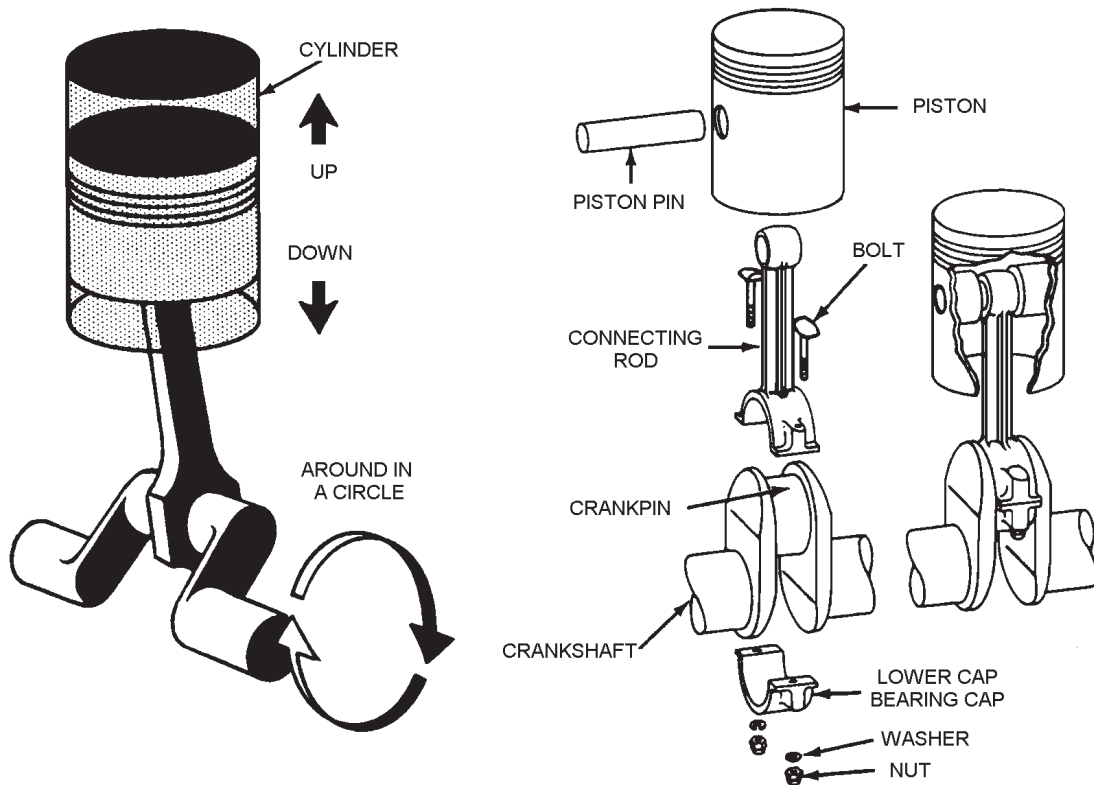

Figure 3-2.—Cylinder, piston, connecting rod, and crankshaft for a 1-cylinder engine.

ASF03002

downward with the piston in a straight line. The lower end of the connecting rod moves down and in a circular motion at the same time. This moves the throw and, in turn, the throw rotates the crankshaft; this rotation is the desired result. So remember, the crankshaft and connecting rod combination is a mechanism for the purpose of changing straight line, or reciprocating motion, to circular or rotary motion.

BASIC ENGINE STROKES

Each movement of the piston from top to bottom or from bottom to top is called a stroke. The piston takes two strokes (an upstroke and a down stroke) as the crankshaft makes one complete revolution. When the piston is at the top of a stroke (fig. 3-3), it is at top dead center (TDC). When the piston is at the bottom of a stroke (fig. 3-4), it is at bottom dead center (BDC). These positions are called "rock positions" and will be discussed further in this chapter.

The basic engine you have studied so far has no provisions for getting the fuel-air mixture into the cylinder or burned gases out of the cylinder. To do this, there are two openings in the enclosed end of a cylinder. One of the openings, or ports, permits an intake of air or an intake of a mixture of fuel and air into the

combustion area of the cylinder. The other opening or port permits the burned gases to escape from the cylinder. The two ports have valves in them. These valves, activated by the camshaft, close off either one or the other of the ports, or both of them, during various stages of engine operation. The camshaft has a number of lobes along its length that open the valves and hold them open for the correct length of time during the piston stroke. The camshaft is driven by the crankshaft through timing gears, or by means of a timing chain. On a 4-stroke cycle engine, the camshaft turns at one-half the crankshaft speed. This permits each valve to open and close once for every two revolutions of the crankshaft. One of the valves, called the intake valve, opens to admit an intake of air or a mixture of fuel and air into the cylinder. The other valve, called the exhaust valve, opens to allow the escape of burned gases after the fuel-and-air mixture has burned.

For the purpose of explanation, we will illustrate the action of a 4-stroke cycle gasoline engine. This type of engine is referred to as a 4-stroke cycle because it requires four complete strokes of the piston to complete one engine cycle. The action of a 4-stroke cycle engine may be divided into four parts: the intake stroke, the compression stroke, the power stroke, and the exhaust stroke.

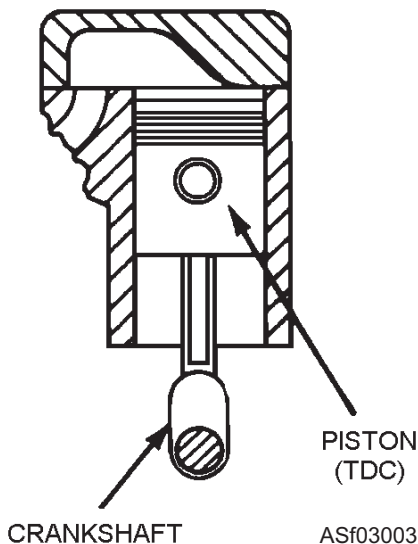

Figure 3-3.—Piston top dead center (TDC).

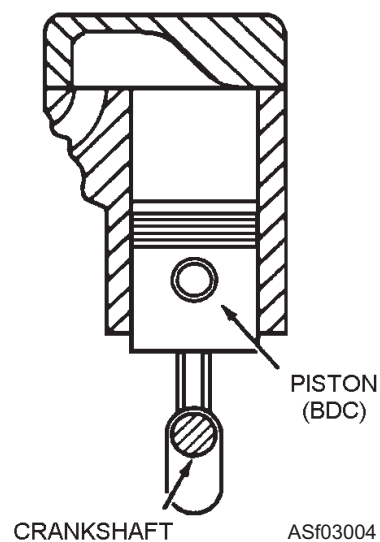

Figure 3-4.—Piston bottom dead center (BDC).

Intake Stroke

The first stroke in the sequence is called the intake stroke (fig. 3-5). During this stroke, the piston is moving downward and the intake valve is open. This downward movement of the piston produces a partial vacuum in the cylinder, and fuel-air mixture rushes into the cylinder past the open intake valve. This is somewhat the same effect as when you drink through a straw. A partial vacuum is produced in the mouth and the liquid moves up through the straw to fill the vacuum.

Compression Stroke

When the piston reaches bottom dead center at the end of the intake stroke and is at the bottom of the cylinder, the intake valve closes. This seals the upper end of the cylinder. As the crankshaft continues to rotate, it pushes up, through the connecting rod, on the piston. The piston is pushed upward and compresses the combustible mixture in the cylinder; this is called the compression stroke (fig. 3-5). In gasoline engines, the mixture is compressed to about one-eighth of its original volume, which is called an 8 to 1 compression

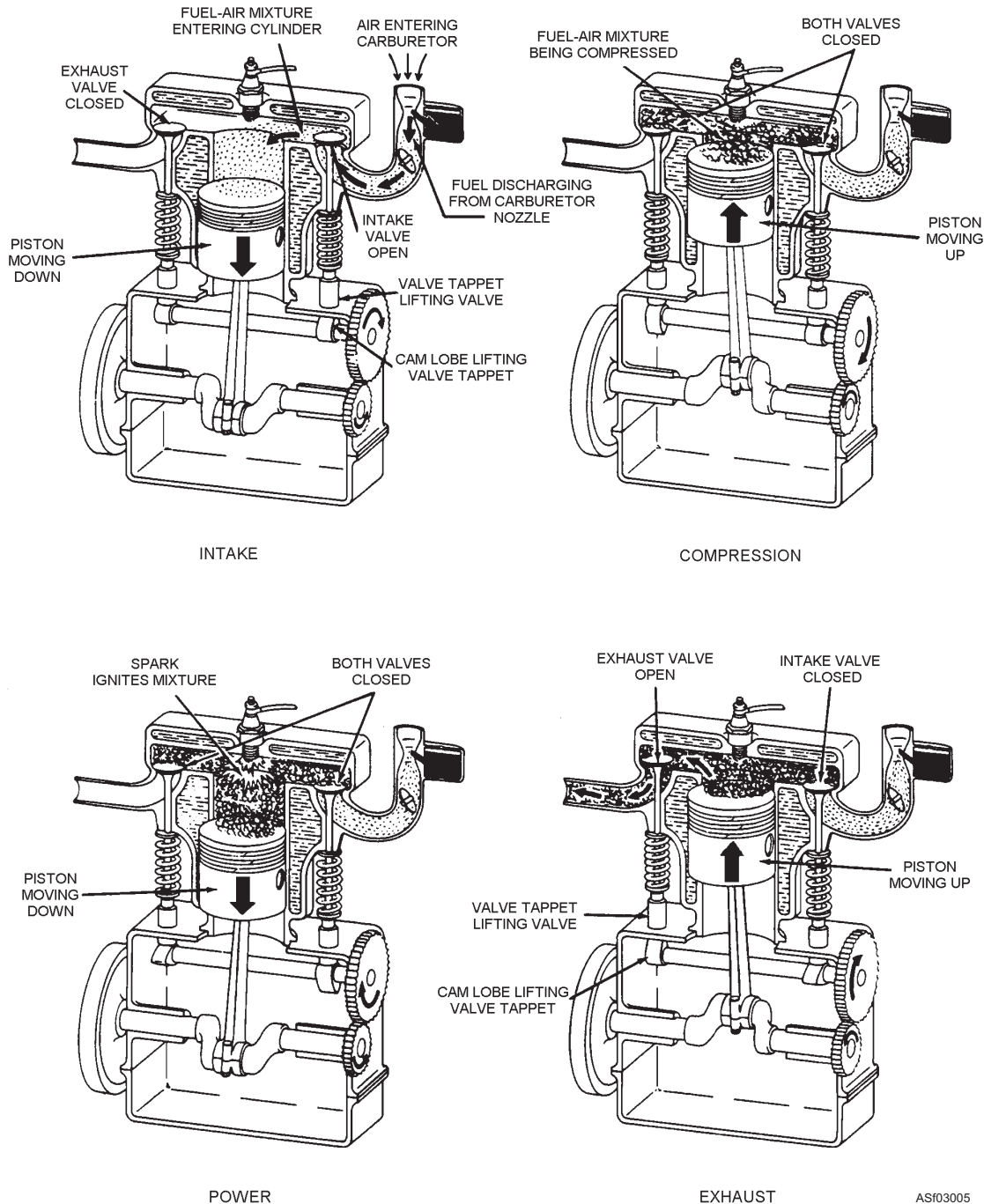

Figure 3-5.—Four-stroke cycle in a gasoline engine.

ASf03005

ratio. This compression of the fuel-air mixture increases the pressure within the cylinder. Compressing the mixture in this way makes it more combustible, as not only does the pressure in the cylinder increase, but the temperature of the mixture as well.

Power Stroke

As the piston reaches top dead center at the end of the compression stroke and moves to the top of the cylinder, the compressed fuel-air mixture is ignited. The ignition system causes an electric spark to occur suddenly in the cylinder, and the spark ignites the fuel-air mixture. In burning, the mixture gets very hot and tries to expand in all directions. The pressure rises to about 600 or 700 pounds per square inch. Since the piston is the only thing that can move, the force produced by the expanding gases forces the piston down. This force, or thrust, is carried through the connecting rod to the crankshaft throw on the crankshaft. The crankshaft is given a powerful push. This is called the power stroke (fig. 3-5). This turning effort, rapidly repeated in the engine and carried through gears and shafts, will turn the wheels of a vehicle and cause it to move.

Exhaust Stroke

After the fuel-air mixture has burned, it must be cleared from the cylinder. This is done by opening the exhaust valve just as the power stroke is finished and the piston starts back up on the exhaust stroke (fig. 3-5). The piston forces the burned gases out of the cylinder past the open exhaust valve.

ENGINE CYCLES

The four strokes (intake, compression, power, and exhaust) are continuously repeated as the engine runs. Now, with the basic knowledge you have of the parts and the four strokes of the engine, let us see what happens during the actual running of the engine. To produce sustained power, an engine must accomplish the same series of events—intake, compression, power, and exhaust over and over again. This series of events is called a cycle. Remember that in a 4-stroke cycle engine, it takes four complete strokes of the piston to complete one engine cycle. Most engines that you will deal with are of the 4-stroke cycle design.

2-Stroke Cycle Engine

In the 2-stroke cycle engine, the same four events (intake, compression, power, and exhaust) take place in only two strokes of the piston and one complete revolution of the crankshaft.

A 2-stroke cycle diesel engine is shown in figure 3-6. Each time the piston moves down, it is on the power stroke. Since this engine does the same thing in half as many strokes as the 4-stroke cycle engine, let's take a closer look at its construction. Instead of intake valves, it has holes, called inlet ports, surrounding the cylinder walls. It also has a blower to force the air into the cylinder when the inlet ports are uncovered by the piston on its downward stroke. Since this engine is a diesel, it requires no spark plugs. A diesel engine requires only a means of introducing fuel into the cylinder, where the fuel burns due to the high temperature of the compressed air.

Here is how one cycle occurs with only two strokes of the piston. The sequence of events is intake, compression, power, and exhaust. Intake begins when the inlet ports are uncovered as the piston moves down in the cylinder. It continues until the piston moves up, covering the ports and blocking the airflow into the cylinder. Very shortly after the inlet ports are covered, the exhaust valve closes and the compression stroke begins. During the compression stroke, the air is compressed to ignite the fuel that is injected near the end of the upward movement of the piston. The pressure from combustion forces the piston down on the power stroke.

As the piston nears the intake ports, the exhaust valve opens, starting the exhaust event and allowing the burned gases to start escaping. The continued downward motion of the piston uncovers the inlet ports, and then air (under pressure) is forced into the cylinder and aids the exhaust event by pushing the burned gases out of the cylinder. This cleaning action is referred to as "exhaust gas scavenging."

4-Stroke Cycle Versus 2-Stroke Cycle

A power stroke is produced every crankshaft revolution within the 2-stroke cycle engine, whereas the 4-stroke cycle engine requires two crankshaft revolutions for one power stroke.

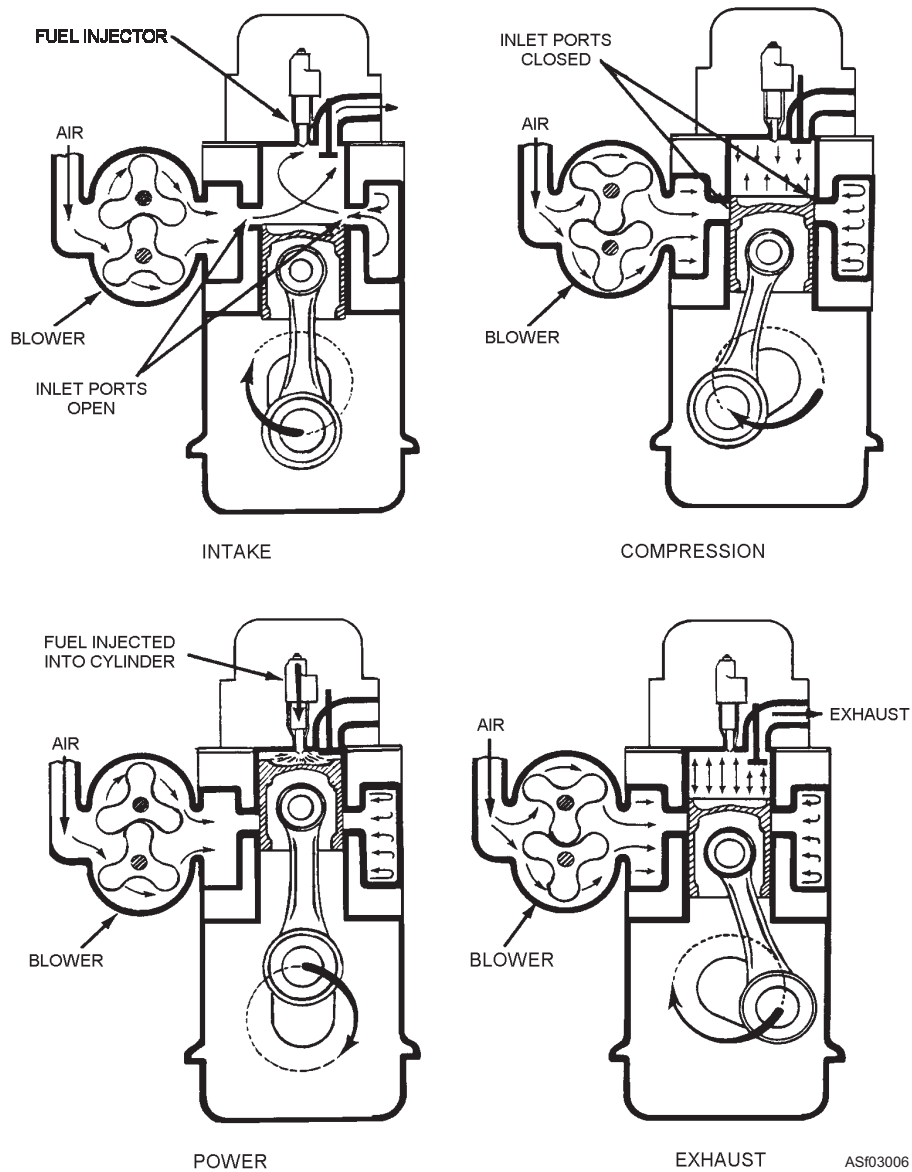

Figure 3-6.—Two-stroke cycle in a diesel engine.

It might appear, then, that the 2-stroke cycle could produce twice as much power as the 4-stroke cycle of the same size, operating at the same speed. However, this power increase is limited to approximately 70 to 80 percent because some of the power is employed to drive a blower that forces the air charge into the cylinder under pressure. Also, the burned gases are not completely cleared from the cylinder, which dilutes the combustible mixture in the cylinder, reducing combustion efficiency. Additionally, because of the much shorter period the intake port is open (as compared to the period the intake valve in a 4-stroke is open), a relatively smaller amount of air is admitted. Hence, with less air, less power per power stroke is produced in a 2-stroke cycle engine of like size

operating at the same speed with conditions being the same.

Multiple-Cylinder Engines

A single cylinder provides only one power impulse every two crankshaft revolutions in a 4-stroke cycle engine and is delivering power only one-fourth of the time. To provide for a more continuous flow of power, modern engines use four, six, eight or more cylinders. The same series of cycles previously discussed take place in each cylinder.

In a 4-stroke cycle, 6-cylinder engine, for example, the throws on the crankshaft are set 120 degrees apart, the throws for cylinders 1 and 6, 2 and 5, and 3 and 4

being in line with each other (fig. 3-7). The cylinders fire or deliver the power strokes in the following order: 1-5-3-6-2-4. Thus, the power strokes follow each other so closely that there is a fairly continuous and even delivery of power to the crankshaft.

Even so, additional leveling off of the power impulses is desirable, so that the engine will run more smoothly. The flywheel shown in figure 3-7 is used to achieve this result.

To understand how a flywheel functions, let us consider a single-cylinder, 4-stroke cycle engine. It is delivering power only one-fourth of the time during the power stroke. During the other three strokes, it is absorbing power to push out the exhaust gas, to pull in a fresh charge, and to compress the charge. The flywheel makes the engine run without varying much in speed during each revolution. It is a heavy steel wheel attached to the end of the crankshaft. When it is rotating, considerable effort is required to slow it down or stop it. Although the wheel does slow down somewhat as it delivers power to the engine during the exhaust, intake, and compression strokes, the wheel speed increases during the engine power stroke. In effect, the flywheel absorbs some of the engine power during the power stroke, and then gives it back to the engine during the other three engine strokes.

In the multicylinder engine, the flywheel functions in a similar manner, absorbing power when the engine tends to speed up during the power strokes and giving up power to the engine when the engine slows down during intervals when little power is being delivered by the engine.

In addition to the engine itself, which is the power producer, there must be accessory systems to provide the engine with other requirements necessary to operate it. These systems are the fuel system, the lubrication or oiling system, the electric system, the cooling system, and an exhaust system.

Q3-1. What happens to the temperature of a gas when it is compressed?

1. It increases
2. It decreases
3. It remains the same
4. It depends on the original pressure before it is compressed

Q3-2. Which of the following items is NOT required for an internal combustion engine to operate?

1. Air
2. Humidity
3. Fuel
4. Ignition

Q3-3. When a piston is at the top of the stroke, it is in what position?

1. Fully flush
2. Top right angle
3. Fully amass
4. Top dead center

Q3-4. The intake valves open when the piston is in which of the following positions?

1. Traveling in the upward direction
2. Nearing the top of the cylinder
3. Traveling in the downward direction
4. At the top of the stroke

Q3-5. What is the primary purpose of the flywheel on an internal combustion engine?

1. It provides a place to attach the transmission
2. It allows for the attachment of the ring gear
3. It increases engine torque
4. It allows the engine to run without varying in engine speed

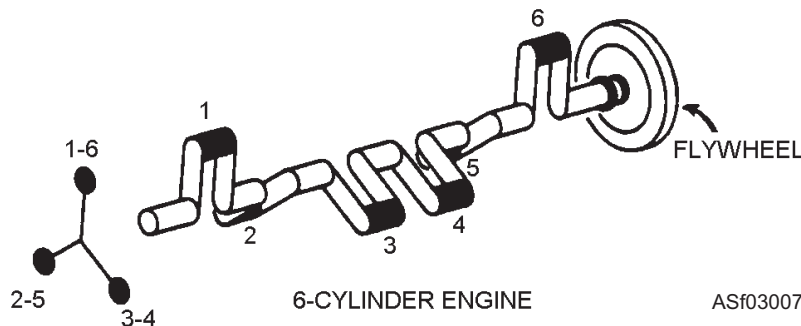

Figure 3-7.—Crankshaft for a 6-cylinder engine.

CLASSIFICATION OF ENGINES

LEARNING OBJECTIVE: Identify various ways engines are classified. Identify the major differences between gasoline and diesel engines.

Engines for aviation support equipment may be classified in a number of ways: type of fuel used, type of cooling employed, or valve and cylinder arrangement. They all operate on the internal combustion principle, and the application of basic principles of construction to particular needs or systems of manufacture has caused certain designs to be recognized as conventional. The most common method of classification is by the type of fuel used; that is, whether the engine burns gasoline or diesel fuel.

GASOLINE ENGINES VERSUS DIESEL ENGINES

Mechanically and in overall appearance, gasoline and diesel engines resemble one another. However, in the diesel engine, many parts are somewhat heavier and stronger, so that they can withstand the higher temperatures and pressures the engine generates. The engines differ also in the fuel used, in the method of introducing it into the cylinders, and in how the fuel-air mixture is ignited. In the gasoline engine, air and fuel

are first mixed together in the carburetor. After this mixture is compressed in the cylinders, it is ignited by an electrical spark from the spark plugs.

The diesel engine has no carburetor. Air alone enters its cylinders, where it is compressed and reaches high temperature due to compression. The heat of compression ignites the fuel injected into the cylinder and causes the fuel-air mixture to burn. The diesel engine needs no spark plugs; the very contact of the diesel fuel with the hot air in the cylinders causes ignition. In the gasoline engine, the heat from compression is not enough to ignite the fuel-air mixture; therefore, spark plugs are necessary.

OPERATING CYCLES

Figure 3-5 illustrates the strokes of the 4-stroke cycle gasoline engine, and figure 3-8 illustrates the strokes of the 4-stroke cycle diesel engine. In each cylinder of either engine, four strokes of the piston produce two revolutions of the crankshaft. In the 2-stroke cycle engine shown in figure 3-6, two piston strokes are required to accomplish these four events. This engine produces less energy per power stroke. But since the power stroke occurs twice as often, it is as efficient, or more so, than a 4-stroke cycle engine of the same size and operating speed.

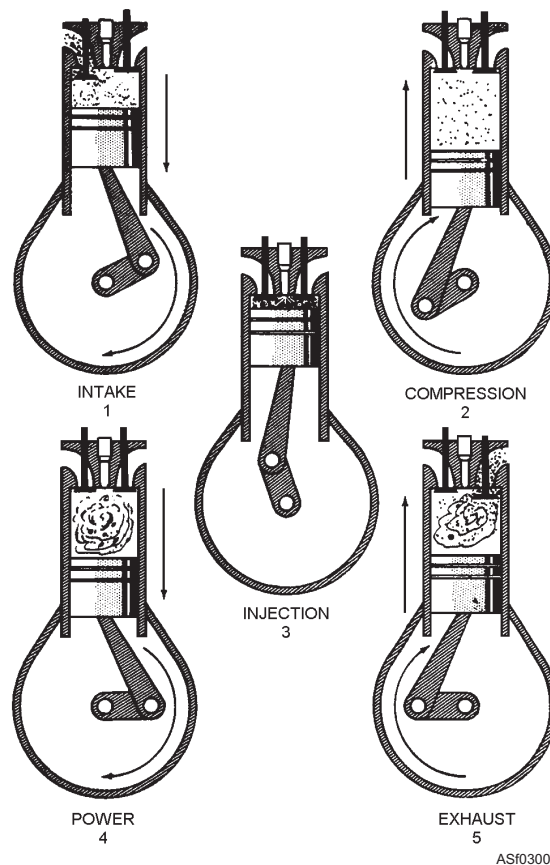

Figure 3-8.—Four-stroke cycle diesel engine.

ARRANGEMENT OF CYLINDERS

Engines are also classified according to the arrangement of the cylinders. One classification is the "in-line," which has all cylinders cast in a straight line above the crankshaft. Another classification is the V-type, which has two banks of cylinders mounted in a V-shape above the crankshaft. While these are the two most common or typical arrangements (fig. 3-9), you might work occasionally with a horizontally opposed engine, whose cylinders are mounted in two side rows, each opposite a central crankshaft.

The cylinders are numbered. The cylinder nearest the front of an inline engine is number 1. The others are numbered 2, 3, 4 etc., from front to rear. In V-type engines, the numbering sequence varies with the manufacturer. You can find the correct order in the technical manual for the engine.

The firing order (which is different from the numbering order) of the cylinders of most of the engines with which you will be working is stamped on the cylinder block or on the manufacturer's nameplate. If you are unable to find the firing order, and no operation or instruction manual is at hand to guide you, turn the engine over by the crankshaft and watch the order in which the intake valves open.

VALVE ARRANGEMENT

The majority of internal combustion engines are classified according to the position and arrangement of the intake and exhaust valves; that is, whether the valves are in the cylinder block or in the cylinder head. Various arrangements are used in classifying the engines.

Q3-6. Which of the following methods is the most common method of classification of an engine?

- 1. The type of cooling*
- 2. The valve arrangement*
- 3. The type of fuel used*
- 4. The cylinder arrangement*

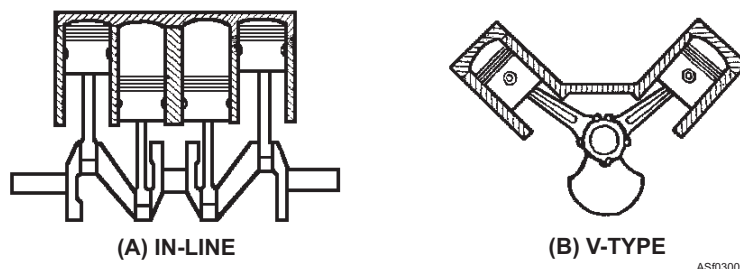

Figure 3-9.—Typical cylinder arrangements.

ENGINE MEASUREMENTS AND PERFORMANCE

LEARNING OBJECTIVE: Identify various engine measurements.

As an AS, you will have to know the various ways in which engines and engine performance are measured. An engine may be measured in terms of cylinder diameter, piston stroke, and number of cylinders. It may be measured, performance wise, in terms of the torque and horsepower it develops and in efficiency. These various terms, their meanings, and their application are discussed here. Also, there are a few engineering terms you will need to know.

DEFINITIONS

You should be familiar with the following definitions:

WORK. Work, in the mechanical sense of the term, is done when a resistance is overcome by a force acting through a measured distance. When a weight is lifted from the ground, work is done on the weight. It is moved upward against the force of gravity. When a tow tractor pulls an aircraft, work is done. If a 1-pound weight is lifted 1 foot, 1 foot-pound of work is done.

ENERGY. Energy is the ability to do work. When work is done on a body, energy is stored in that body. The higher a weight is lifted from the ground, the more energy is stored in the weight. Then, when it falls, it will strike the ground hard; that is, it will do more work on the ground.

POWER. Power is the rate at which work is done. It takes more power to work rapidly than to work slowly. Engines are rated in terms of the amount of work they can do per minute. An engine that can do more work per minute than another is said to be more powerful.

HORSEPOWER. The work capacity of an engine is measured in horsepower. Horsepower (hp) is the power of a horse, or a measure of the rate at which a horse can do work. An average horse can lift a weight of

200 pounds a distance of 165 feet in 1 minute. The amount of work involved here is 33,000 foot-pounds (165 times 200). If 100 pounds were lifted 330 feet, or if 330 pounds were lifted 100 feet, the amount of work would be the same, 33,000 foot-pounds. When this amount of work is done in 1 minute, 1 horsepower is required. If it takes 2 minutes to do this amount of work, then 16,500 foot-pounds per minute, or 1/2 hp, would be required. Applying the formula for horsepower:

$$\text{hp} = \frac{\text{ft-lb. per min}}{33,000} = \frac{L \times W}{33,000 \times t}$$

L = length, in feet, through which W is moved

W = force, in pounds, that is exerted through distance L

t = time, in minutes, required to move W through L

There are a number of devices that you may use to measure the horsepower of an engine. The most common device used for this purpose is the dynamometer.

ENGINE DYNAMOMETER. An engine dynamometer may be used to test an engine that has been removed from the vehicle it drives. If the engine does not develop the manufacturer's recommended horsepower and torque at a specific rpm, you know there is need for further adjustments and/or repairs to the engine.

CHASSIS DYNAMOMETER. The chassis dynamometer is used for automotive service, since it can give a very quick report on engine conditions by measuring output at various speeds and loads. This type of machine is very useful in shop testing and adjusting automatic transmissions.

On the chassis dynamometer (fig. 3-10), the driving wheels of the vehicle are placed on rollers. The engine drives the wheels and the wheels drive the rollers. By loading the rollers varying amounts and by running the

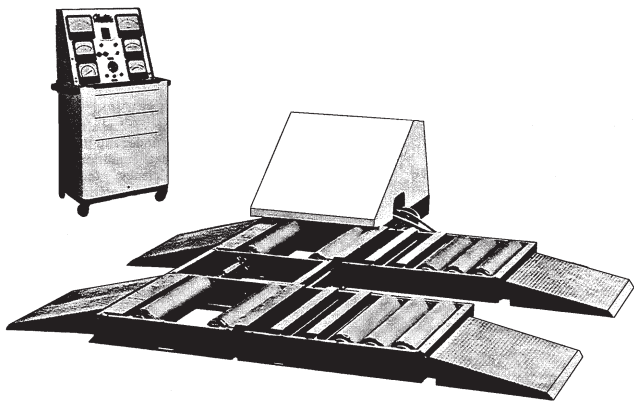

Figure 3-10.—Chassis dynamometer.

engine at different rpm's, nearly all normal driving conditions can be simulated. The tests and checks can be made without the interference of body noises, such as you would have when checking the vehicle on the flight line or deck.

TORQUE WRENCH. Torque is twisting, or turning, effort. When the lid on a jar is loosened, a twisting force, or torque, is applied to it. You apply torque to a wrench when you tighten or loosen a nut. Torque is measured in pound-feet (not to be confused with work, which is measured in foot-pounds). For instance, suppose you use a wrench to tighten a nut on a stud. If the handle of the wrench is 1-foot long and you apply a 10-pound force to its end, 10 pound-foot of torque is applied to the nut. An illustration of a torque wrench in use is shown in figure 3-11.

Do not confuse torque with work or with power. Both work and power indicate motion, but torque does not. It is merely a turning effort the engine applies to the wheels through gears and shafts.

FRICTION. Friction is the resistance to motion between two objects in contact with each other. The reason a sled will not slide on bare earth is because of friction. It slides on snow because snow offers little resistance while the bare earth offers much resistance.

Friction is both desirable and undesirable in an automobile or any other vehicle. Friction in the engine is undesirable because it decreases the power output; in other words, it uses up some of the energy of the engine. This is overcome by using oil so the moving components in the engine will slide or roll over each other smoothly. Friction is desirable in clutches and brakes, because friction is exactly what is needed for them to perform their function properly.

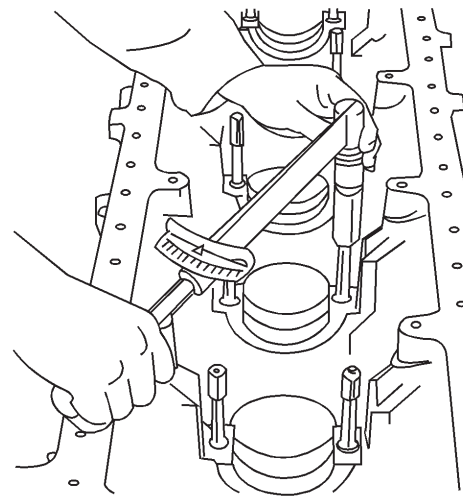

Figure 3-11.—Torque wrench in use, tightening main bearing stud of an engine.

INERTIA. Another term you will often encounter is *inertia*. Inertia is a characteristic of all material objects. It causes them to resist any change of speed or direction of travel. A motionless object tends to remain at rest and a moving object tends to keep moving at the same speed and in the same direction. A good example of inertia is the tendency of your automobile to keep moving after your foot is removed from the accelerator. You apply the brake to overcome the inertia of the automobile, or its tendency to keep moving.

EFFICIENCY. The term *efficiency* means the relationship between the actual and theoretical power output.

VOLUMETRIC EFFICIENCY. Volumetric efficiency is the ratio between the amount of fuel-air mixture that actually enters the cylinder and the amount that could enter under ideal conditions. The greater the volumetric efficiency, the greater the amount of fuel-air mixture entering the cylinder; and the greater the amount of fuel-air mixture, the more power produced from the engine cylinder.

Volumetric efficiency can be improved by using a blower or air-compressing device. On gasoline engines, this device is called a supercharger. It raises the air pressure above atmospheric pressure so that the air is pushed into the cylinder.

MECHANICAL EFFICIENCY. Mechanical efficiency is the relationship between brake horsepower (bhp) and indicated horsepower (ihp). Brake horsepower is the actual power put out by the engine, while ihp is the power developed inside the cylinder. From mechanical efficiency you can tell what percentage of the power developed in the cylinder is actually being delivered by the engine. The remaining percent of power that is not delivered is consumed by friction, sometimes computed as friction horsepower (fhp).

THERMAL. The term *thermal* means, "of or pertaining to heat." The thermal efficiency of an engine is the relationship between the power output and the energy in the fuel burned to produce this output. Thermal efficiency has a direct relationship to heat losses in the engine. Because there is a great deal of heat lost during engine operation, thermal efficiency usually remains quite low at about 20 to 25 percent.

LINEAR MEASUREMENTS

The size of an engine cylinder is usually indicated in terms of bore and stroke (fig. 3-12). Bore is the inside

diameter of the cylinder. Stroke is the distance between top dead center and bottom dead center. The bore is always measured first. For example, a 3.5 × 4 cylinder means that the cylinder bore, or diameter, is 3.5 inches and the length of the stroke is 4 inches. These measurements are used to figure piston displacement.

Piston displacement is the volume of space that the piston displaces as it moves from one end of the stroke to the other. Thus, the piston displacement in a 3.5-inch by 4-inch cylinder would be the area of a 3.5-inch circle multiplied by 4, the length of the stroke. The area of a circle is πR^2 where R is the radius (that is, one-half the diameter) of the circle. Letting S be the length of the stroke, the formula for the volume (V) is

$$V = \pi R^2 \times S$$

If this formula is applied to figure 3-12, the piston displacement is computed as follows:

$$R = 1/2 \text{ the diameter} = 1/2 \times 3.5 \text{ in.} = 1.75 \text{ in.}$$

$$\pi = 3.14$$

$$S = 4 \text{ in.}$$

then

$$V = 3.14(1.75 \text{ in.})^2 \times 4 \text{ in.}$$

$$V = 3.14 \times 3.06 \text{ in.} \times 4 \text{ in.}$$

$$V = 38.43 \text{ cubic inches}$$

The total displacement of an engine is found by multiplying the volume of one cylinder by the total number of cylinders.

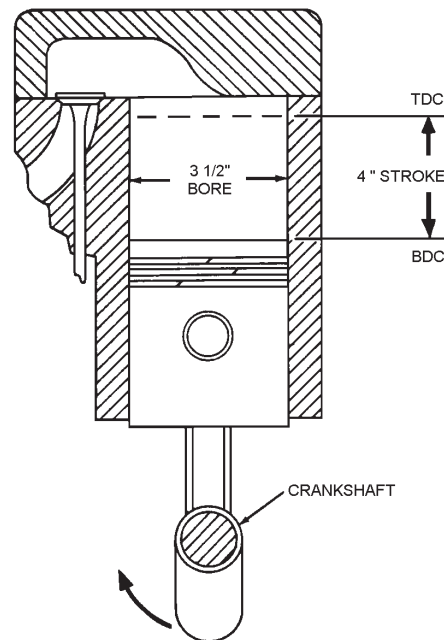

Figure 3-12.—Bore and stroke of an engine cylinder.

ENGINE PERFORMANCE

The compression ratio of an engine is a measurement of how much the fuel-air charge is compressed in the engine cylinder. It is calculated by dividing the volume of one cylinder with the piston at BDC by the volume with the piston TDC (fig. 3-13). You should note that the volume (fig. 3-13, view B) is called the clearance volume.

For example, suppose that an engine cylinder has a volume of 63 cubic inches with the piston at BDC, and a volume of 10 cubic inches with the piston at TDC. The compression ratio of this cylinder would be 6.3 to 1, determined by dividing 63 cubic inches by 10 cubic inches. That is, the fuel-air mixture is compressed from 63 to 10 cubic inches, or to about 1/6 of its original volume.

Two major advantages of increasing compression ratio are that power and economy of the engine improve without any added weight or size. The improvements come about because with a higher compression ratio the fuel-air mixture is squeezed more. This means a higher initial pressure at the start of the power stroke. As a result, there is more force on the piston for a greater part of the power stroke. Therefore, more power is obtained from each power stroke.

Increasing the compression ratio, however, brings up some problems. Fuel will stand only a certain amount of squeezing without knocking. Knocking is the sudden burning of the fuel-air mixture, which causes a quick increase in pressure and a resulting rapping or knocking noise. The fuel chemists have overcome this knocking by creating antiknock fuels.

Oxygen must be present if combustion is to occur in the cylinder, and since air is the source of supply of oxygen used in engines, the problem arises of getting the proper amount of air to support combustion. This factor is commonly known as the "fuel-air ratio." A gasoline engine normally operates at intermediate speeds on a 15 to 1 ratio; that is, 15 pounds of air to 1 pound of gasoline.

TIMING

In a gasoline engine, the valves must open and close at the proper times with regard to piston position and stroke. In addition, the ignition system must produce the sparks at the proper time so that the power strokes can start. Both valve and ignition system action must be properly timed if good engine performance is to be obtained.

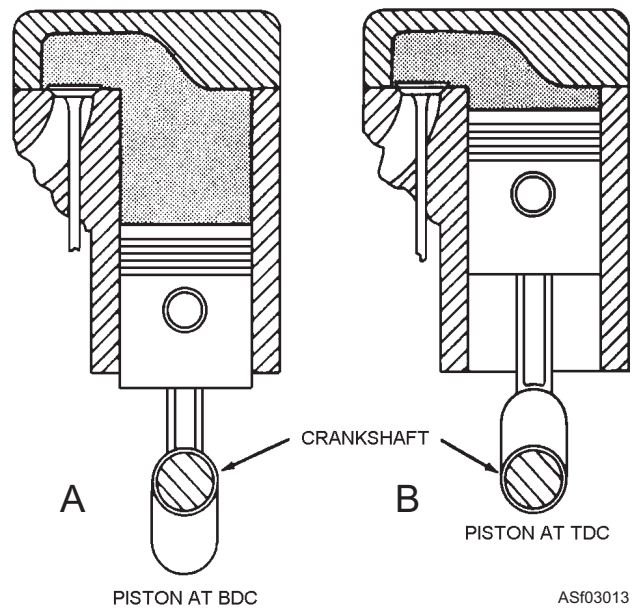
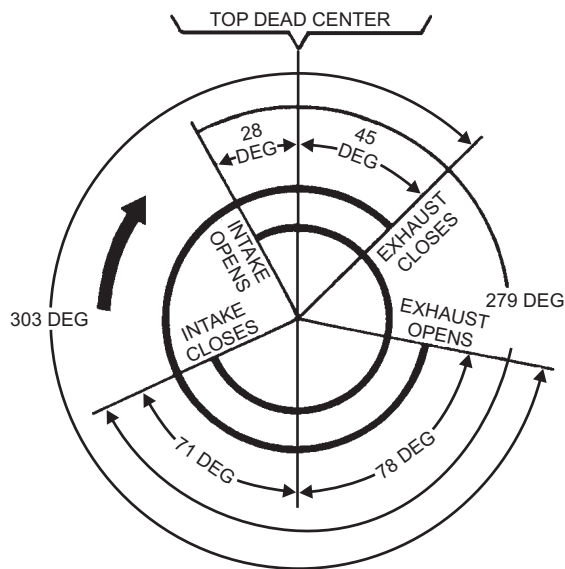

Figure 3-13.—Compression ratio is ratio between views (A) and (B).

Valve Timing

Valve timing refers to the exact times in the engine cycle at which the valves trap the mixture and then allow the burned gases to escape. The valves must open and close so that they are constantly in step with the piston movement in the cylinder where they are located. The position of the valves is determined by the camshaft; the position of the piston is determined by the crankshaft. Correct valve timing is obtained by providing the proper relationship between the camshaft and the crankshaft. In actual operation, the time at which the valves operate will vary, as shown in the typical valve timing diagram (fig. 3-14).

When the piston is at TDC, the crankshaft can move 15 degrees to 20 degrees without causing the piston to move up and down any noticeable distance. This is one of the two rock positions (fig. 3-15). When the piston moves up on the exhaust stroke, considerable momentum is given to the exhaust gases as they pass out through the exhaust valve port; but if the exhaust valve closes at TDC, a small amount of the gases will be trapped and will dilute the incoming fuel-air mixture when the intake valves open. Since the piston has little downward movement while in the rock position, the exhaust valve can remain open during this period, and thereby permit a more complete scavenging of the exhaust gases.



4-STROKE VALVE TIMING DIAGRAM

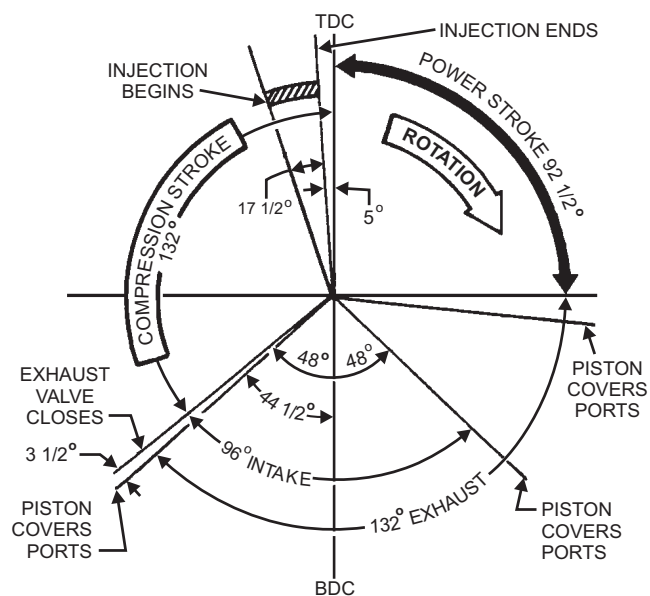

2-STROKE VALVE TIMING DIAGRAM

ASf03014

Figure 3-14.—Typical valve timing diagrams.

Ignition Timing

Ignition timing refers to the timing of the spark plug firing with relation to the piston position during the compression stroke. The ignition system is timed so that the spark occurs before the piston reaches TDC on the compression stroke. This gives the mixture enough time to ignite and start burning. If this time were not provided (that is, if the spark occurred at or after TDC), then the pressure increases would take place too late to provide a full power stroke.

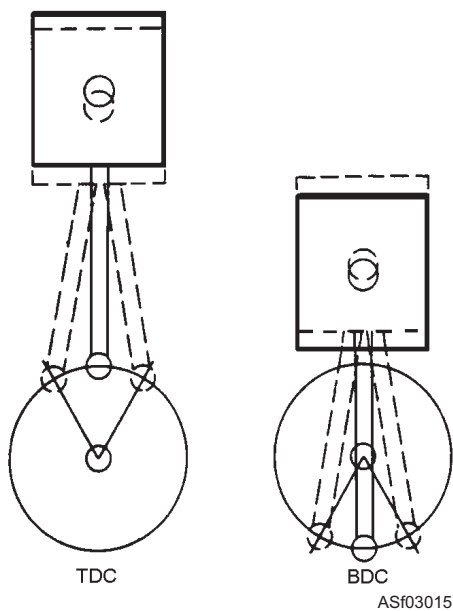

Figure 3-15.—Rock positions.

At higher speeds, there is still less time for the fuel-air mixture to ignite and burn. To compensate for this, and thereby avoid power loss, the ignition system includes both a vacuum and a mechanical advance mechanism that alters ignition timing as engine speed increases.

Q3-7. What is the major difference in the ignition processes of a gasoline and diesel engine?

1. A gasoline engine uses spark plugs to ignite the fuel and a diesel engine heats the air in the cylinder by compressing it to ignite the fuel
2. A gasoline engine uses spark plugs and a diesel engine uses an igniter coil to ignite the fuel
3. A gasoline engine uses electronic ignition and a diesel engine uses an igniter coil to ignite the fuel
4. A gasoline engine works on the theory of high compression with low ignition and the diesel engine works on the theory of high compression with high ignition

Q3-8. The rate at which work is done is identified by which of the following terms?

1. Energy
2. Power
3. Inertia
4. Wattage

Q3-9. *The resistance to motion between two objects is known by what term?*

1. *Impedance*
2. *Inertia*
3. *Friction*
4. *Efficiency*

Q3-10. *Which of the following statements best describe the advantages of increasing the compression of an engine?*

1. *The cost of the engine will be decreased*
2. *The engine will perform better at high altitudes*
3. *The amount of air needed to run the engine will decrease*
4. *The power and economy will increase*

Q3-11. *Which of the following components determines the position of the valves in an engine?*

1. *The crankshaft*
2. *The piston*
3. *The camshaft*
4. *The flywheel*

ENGINE CONSTRUCTION

LEARNING OBJECTIVES: Identify the components of gasoline and diesel engines. Identify procedures for inspecting, checking, testing, and adjusting gasoline and diesel engines. Identify procedures for troubleshooting gasoline and diesel engines.

As an AS, you are concerned with the many stationary and moving parts of an internal combustion engine, as well as how these parts are made, what materials they are made of, and their relationship to one another in the smooth and efficient operation of the internal combustion engine.

You will also have to diagnose malfunctions of the engine and determine what method to use in the correction of these malfunctions. Since gasoline and diesel engines used in today's aviation support equipment are all basically the same internally, the majority of items covered in this course apply to both.

Basic engine construction varies little, regardless of size and design of the engine. The intended use of an engine must be considered before the design and size

can be determined. The temperature at which an engine will operate has a great deal to do with determining what metals must be used in its construction.

To simplify the service parts problem in the field, and also to simplify servicing procedures, the present trend in engine construction and design is toward what is called "engine families." There must, of necessity, be many different kinds of engines because there are many kinds of jobs to be done. However, the service and service part problem can be simplified by designing engines so that they are closely related in cylinder size, valve arrangement, etc. As an example, the GM series 71 engines can be obtained in 2-, 3-, 4-, and 6-cylinder inline models. GM V-type engines come in 6-, 8-, 12-, and 16-cylinder models. These engines are designed so that many of the internal parts can be used on any of the models.

STATIONARY PARTS OF AN ENGINE

The stationary parts of an engine include the cylinder block, cylinder head or heads, crankcase, and the exhaust and intake manifolds. These parts furnish the framework of the engine. All movable parts are attached to or fitted into this framework.

Cylinder Block

The engine cylinder block is the basic frame of a liquid-cooled engine, whether it be inline, horizontally opposed, or V-type. The cylinder block and crankcase are often cast in one piece; this is the heaviest single piece of metal in the engine. (See fig. 3-16.) In most large diesel engines, such as those used in power plants, the crankcase is cast separately and is attached to a heavy stationary engine base.

In practically all automotive and aviation support equipment, however, the cylinder block and crankcase are cast in one piece. This type of cylinder block is designated as a cast-en-block or monoblock engine. In this course we are concerned primarily with monoblock liquid-cooled engines.

The cylinders of a liquid-cooled engine are surrounded by interconnecting passages cast in the block. Collectively these passages form the water jacket, which allows the circulation of coolant through the cylinder block and the cylinder head to carry off the excessive heat created by combustion.

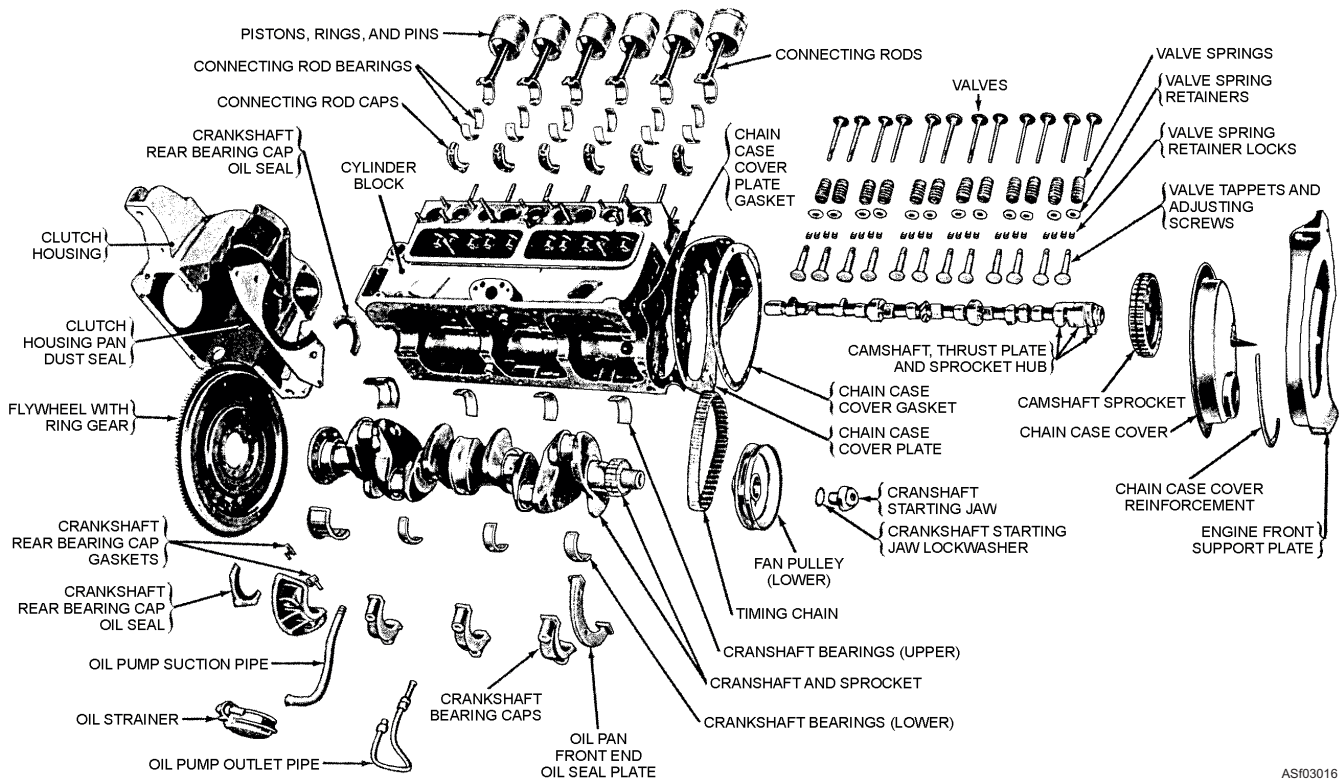

ASf03016

Figure 3-16.—Cylinder block and components.

The water jacket is accessible through holes machined in the head and block to allow removal of the material used for the casting of the cylinder block. These holes are called "core holes" and are sealed by

core hole plugs (freeze plugs). These plugs are of two types: cup and disc. Figure 3-17 shows typical installation of these plugs.

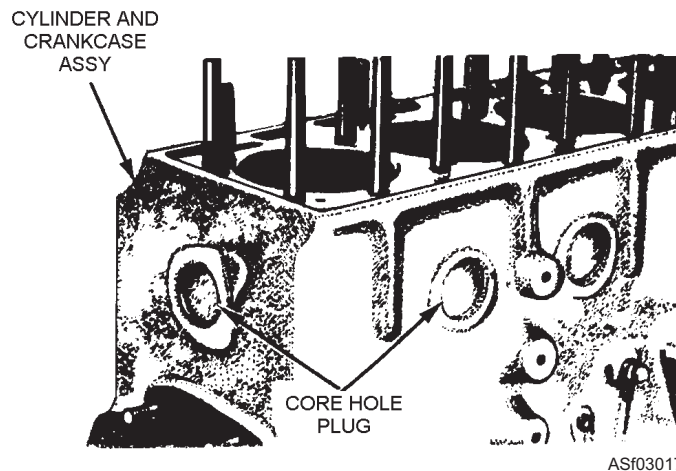

ASf03017

Figure 3-17.—Core hole plugs installed in cylinder block.

The air-cooled engine differs from the liquid-cooled engine in that the cylinders have closely spaced fins surrounding the barrel. (See fig. 3-18.) These fins provide a greatly increased surface area from which heat can be dissipated. This is in contrast to the liquid-cooled engine, which has a water jacket around its cylinders.

The cylinder block is cast from gray iron or iron alloyed with other metals such as nickel, chromium, or molybdenum. Some lightweight engine blocks are made from aluminum alloy. Cylinders are machined by grinding or boring to give them the desired true inner surface. During normal engine operation, cylinder walls will wear out-of-round, or they may become cracked and scored if not properly lubricated or cooled. Liners (fig. 3-19) made of metal alloys resistant to wear are used in many gasoline engines and practically all diesel engines to lessen wear. Liners for 4-stroke cycle engines do not have air inlet ports, as shown in figure 3-20. After they have been worn beyond the maximum oversize, the liners can be replaced individually, permitting the use of standard pistons and rings. Thus, you can avoid replacing the entire cylinder block.

The liners are inserted into a hole in the block with either a press fit or a slip fit. Liners are further designated as wet-type or dry-type. The wet-type liner comes in direct contact with the coolant and is sealed at the top by the use of a metallic sealing ring and at the bottom by a rubber sealing ring; the dry-type liner does not contact the coolant. Special precautions must be taken with the seals when installing a wet-type liner. Use a lubricant on the seals to prevent them from rolling or twisting. Soap or brake fluid is recommended for this purpose. Continued overheating of an engine during operation or improperly installed seals will allow the coolant to enter the crankcase and contaminate the engine oil. To determine which seals are leaking, it is necessary to remove the engine oil pan or inspection covers on the crankcase and pressurize the cooling system, observing the liners through the crankcase for leakage.

Cylinder wear is caused by dirt getting through the air cleaner and acting as a grinding compound, by side thrust of the piston, and by pressure of the piston rings against the cylinder walls. Liners, therefore, do not completely prevent wear. To check on wear and to determine how much overhaul is required, use special

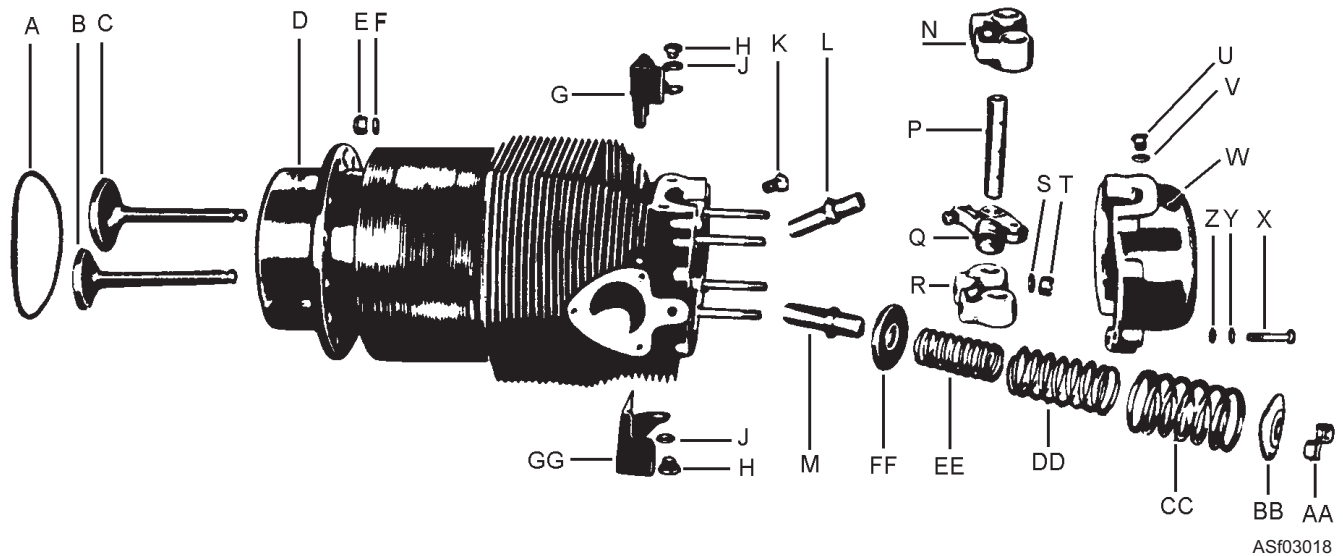

ASF03018

- | | | |
|--|--|---|
| <ul style="list-style-type: none"> A. O-ring gasket B. Exhaust valve C. Intake valve D. Cylinder E. Cylinder barrel nut F. Lock nut G. Dome fin deflector (LH) H. Bolt J. Lock washer K. Primer nozzle assembly L. Intake valve guide | <ul style="list-style-type: none"> M. Exhaust valve guide N. Rocker support bracket P. Rocker shaft Q. Rocker R. Rocker support bracket S. Washer T. Slotted nut U. Rocker box cover plate bolt V. Tab washer W. Valve rocker cover X. Bolt | <ul style="list-style-type: none"> Y. Lock washer Z. Washer AA. Valve lock BB. Valve spring retainer CC. Outer valve spring DD. Intermediate valve spring EE. Inner valve spring FF. Valve spring seat GG. Dome fin deflector (RH) |
|--|--|---|

Figure 3-18.—Cylinder of an air-cooled engine.

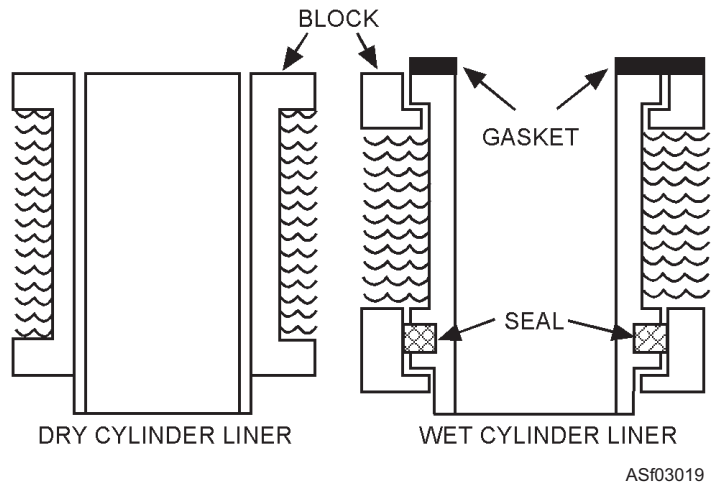

ASf03019

Figure 3-19.—Cylinder liner application.

gauges and micrometers to obtain correct measurements. Check the measurements you get with the specifications given in the manufacturer's manual. Most cylinder wall wear occurs at the top of piston travel where pressures are greatest.

Engine blocks for L-head engines contain the passageways for the valves and valve ports. The lower part of the block (crankcase) supports the crankshaft (with main bearings and bearing caps) and also provides a place for fastening the oil pan.

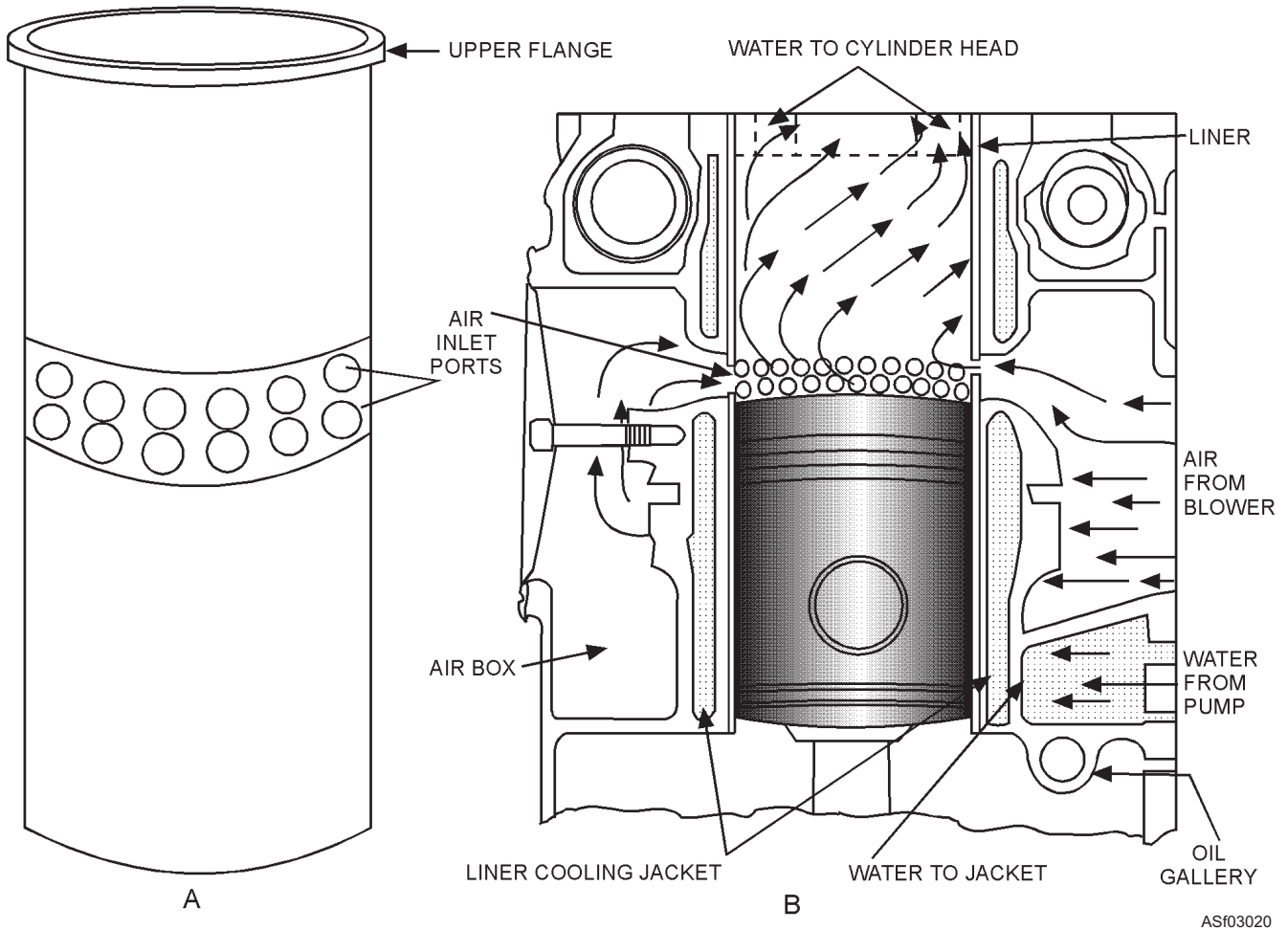

ASf03020

Figure 3-20.—(A) Dry-type liner for 2-cycle General Motors series engines. (B) Section through series 71 block.

The camshaft is supported in the cylinder block by bushings that fit into machined holes in the block. On L-head inline engines, the intake and exhaust manifolds are attached to the side of the cylinder block.

Cylinder Head

The cylinder head provides the combustion chamber for the engine cylinders. It is built to conform to the arrangement of the valves: L-head, I-head, or other. Cylinder heads are usually cast from iron, from iron alloyed with other metals, or from aluminum alloy. Aluminum has the advantage of combining lightness with high heat conductivity. That is, an aluminum head will tend to run cooler, other factors being equal. A high degree of heat conductivity is especially desirable because it assures that the heat of combustion will be rapidly carried away, thus preventing the formation of hot spots, which cause preignition (premature ignition of the fuel-air mixture in the cylinder).

In the water-cooled engine, the cylinder head (fig. 3-21) is bolted to the top of the cylinder block to close the upper end of the cylinders. It contains passages, matching those of the cylinder block, that allow the cooling water to circulate in the head. The head also

helps retain compression in the cylinders. In the gasoline engine there are threaded holes in the cylinder head that lead into the combustion chamber. The spark plugs are screwed into these holes.

In the diesel engine, the cylinder head may be cast in a single unit or may be cast for a single cylinder or two or more cylinders. Separated head sections (usually covering 1, 2, or 3 cylinders in large engines) are easier to handle and can be readily removed. They do not warp easily, are cheaper to replace, and require less work for a teardown.

The L-head type of cylinder head shown in figure 3-21 is a comparatively simple casting. It contains water jackets for cooling and openings for spark plugs. Pockets into which the valves operate are also provided. Each pocket serves as a part of the combustion chamber. The fuel-air mixture is compressed in the pocket as the piston reaches the end of the compression stroke. Note that the pockets have a rather complex curved surface. This shape has been carefully designed so that the fuel-air mixture, in being compressed, will be subjected to violent turbulence. This turbulence assures uniform mixing of the fuel and air, thus improving the combustion process.

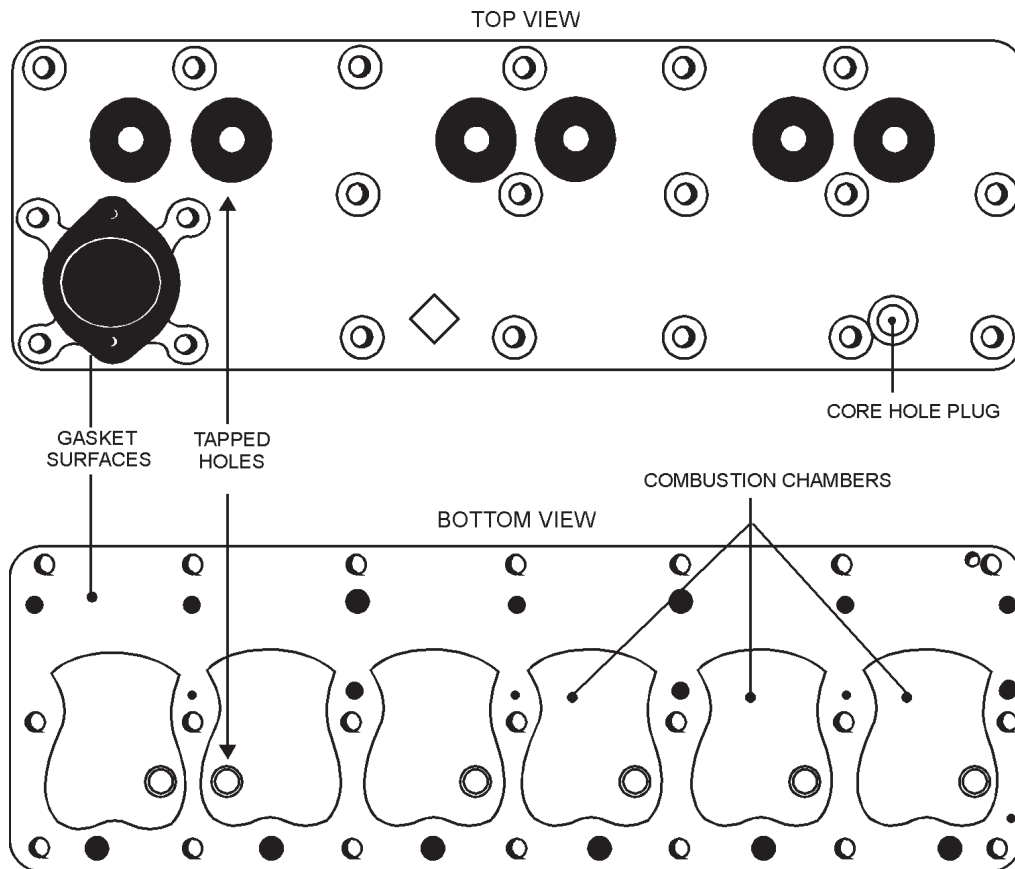

Figure 3-21.—Cylinder head for L-head engine.

ASf03021

The I-head (overhead-valve) type of cylinder head (fig. 3-22) contains not only water jackets for cooling spark-plug openings, valve pockets, and part of the combustion chamber, but it also contains and supports the valves and valve operating mechanisms. In this type of cylinder head, the water jackets must be large enough to cool not only the top of the combustion chamber but also the valve seats, valves, and valve-operating mechanisms.

Crankcase

The crankcase is that part of the engine block below the cylinders. It supports and encloses the crankshaft and provides a reservoir for the lubricating oil. Sometimes there are places provided on the crankcase for the mounting of the oil pump, oil filter, starting motor, and the generator or alternator. The lower part of the crankcase is the oil pan, which is bolted at the bottom. The oil pan may be made of pressed steel or cast metal and holds the lubricating oil for the engine. Since it is the lowest part of the power plant, the oil pan must be strong enough to withstand blows from flying stones and obstructions sticking up from the road surfaces. Checking for dents in the pan and oil leaks is an important part of your job. Get into the habit of checking the spot where the vehicle was parked for water or oil leakage.

The oil pump in the lubricating system draws oil from the oil pan and sends it to working parts in the engine. As the oil drains off and runs down into the pan, it is picked up by the oil pump again and recirculated through the engine.

The crankcase also has mounting brackets that support the entire engine on the vehicle frame. These brackets are either an integral part of the crankcase or are bolted to it in such a way that they support the engine at three or four points. These points of contact usually are cushioned by rubber mounts that insulate the frame and body of the vehicle from engine vibration, and therefore, prevent damage to the engine supports and the transmission.

As a result of normal engine operation, water or gasoline may seep down and appear in the crankcase. These liquids evaporate after the engine reaches operating temperature, and the vapors are removed by ventilation.

Exhaust Manifold

The exhaust manifold is essentially a tube that carries waste products of combustion from the cylinders. On L-head engines, the exhaust manifold is bolted to the side of the engine block; on overhead-valve engines, it is bolted to the side of the

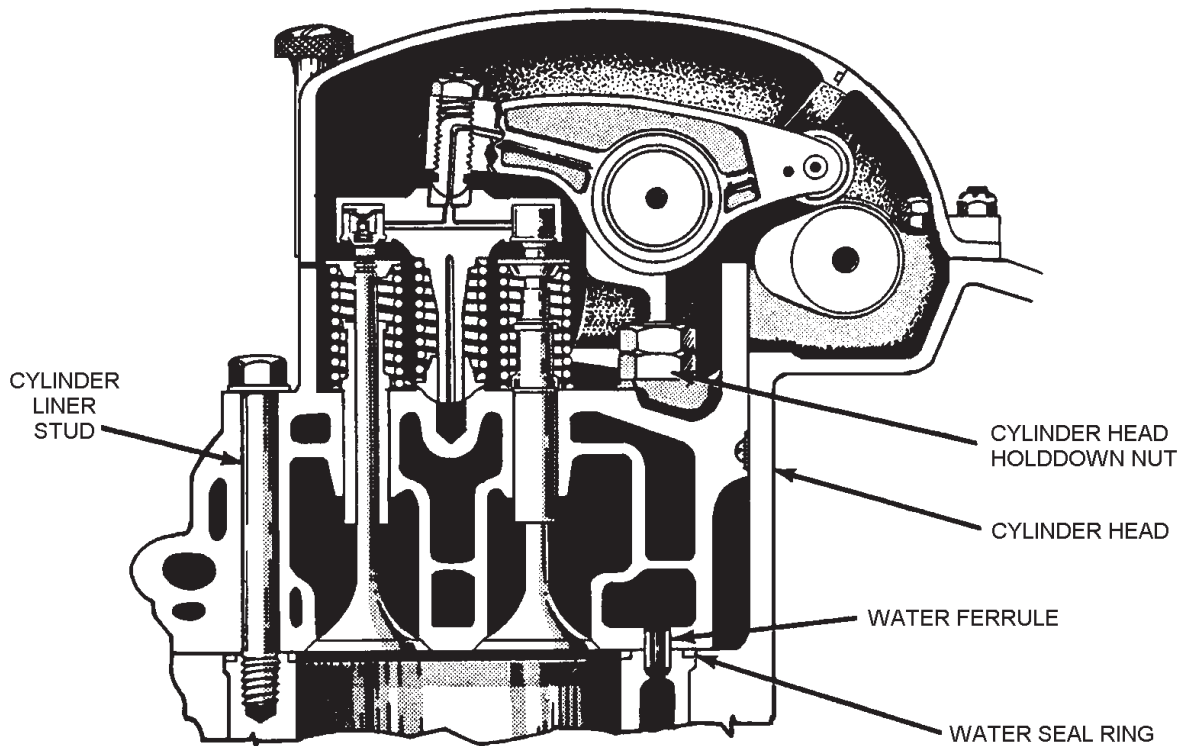

Figure 3-22.—Cylinder head for overhead valve engine.

ASF03022

engine cylinder head. Exhaust manifolds may be single iron castings or may be cast in sections. They have a smooth interior surface with no abrupt changes in size. (See figure 3-23.)

Exhaust manifolds on today's automobiles are constantly changing in design to allow the use of various types of emission controls. The most common type is the large diameter exhaust manifold, which is designed for use with the air injection system.

Intake Manifold

The intake manifold on a gasoline engine carries the fuel-air mixture from the carburetor and distributes it as evenly as possible to the cylinders. On a diesel engine, the manifold carries only air to the cylinders. The intake manifold is attached to the block on L-head engines (fig. 3-23) and to the side of the cylinder head on overhead-valve engines.

In gasoline engines, smooth and efficient engine performance depends largely on whether or not the fuel-air mixtures that enter each cylinder are uniform in strength, quality, and degree of vaporization. The inside walls of the manifold must be smooth to offer little obstruction to the flow of the fuel-air mixture. The

manifold is designed to prevent collecting of fuel at the bends in the manifold.

The intake manifold should be as short and straight as possible to reduce the chances of condensation between the carburetor and cylinders. To assist in vaporization of fuel, some intake manifolds are constructed so that part of their surfaces can be heated by hot exhaust gases.

Intake manifolds on today's gasoline engines have special passages for allowing exhaust gases to re-enter the engine. These intake manifolds are used on engines equipped with an exhaust gas recirculation system.

Gaskets

The principal stationary parts on an engine have just been explained. The gaskets (fig. 3-24) that serve as seals between these parts require as much attention during assembly as any other part. It is impractical to machine all surfaces so that they fit together to form a perfect seal. The gaskets make a sealed joint that will prevent loss of compression, coolant, or lubricant.

The cylinder head gasket is placed between the cylinder head and engine block to maintain a gas, oil,

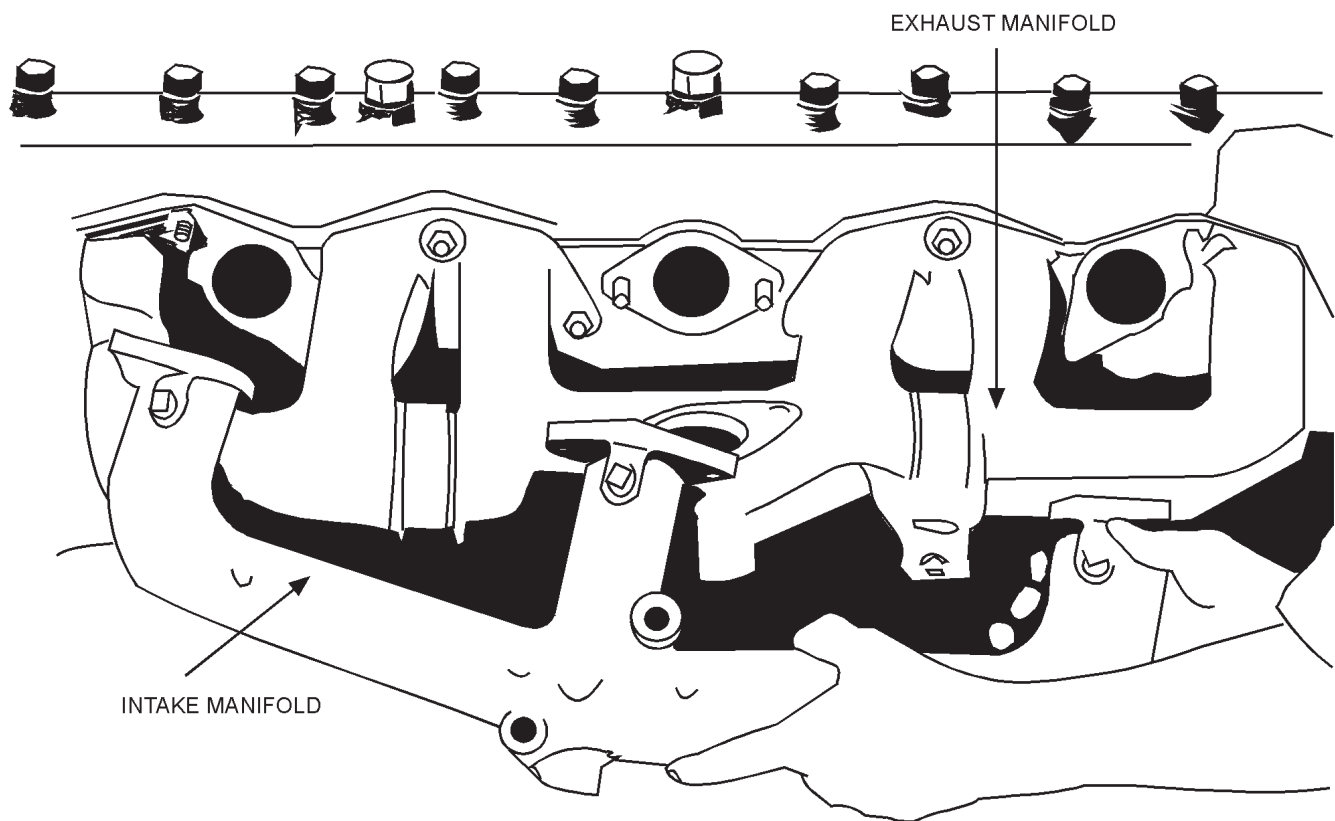

ASf03023

Figure 3-23.—Intake and exhaust manifolds.

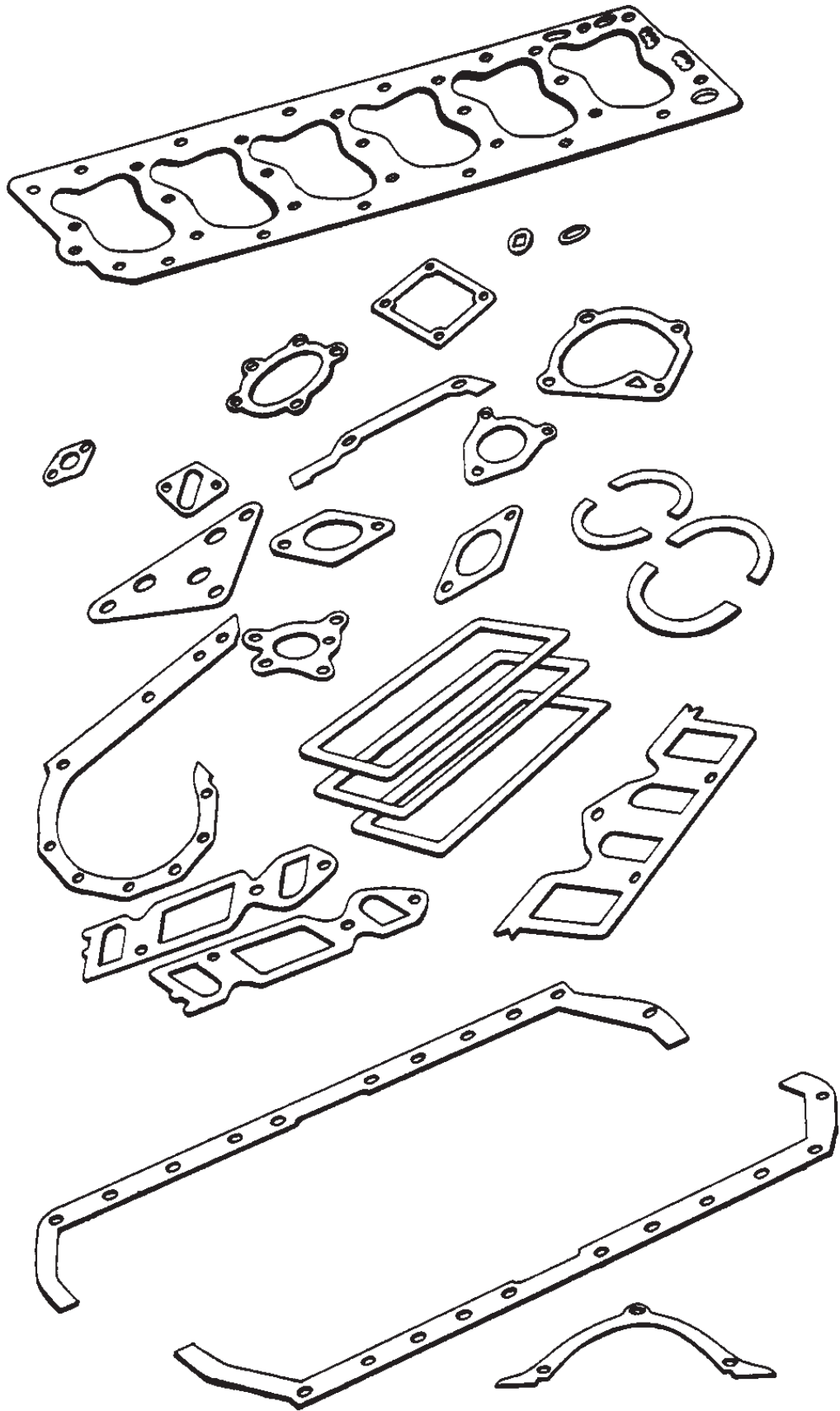

ASf03024

Figure 3-24.—Engine overhaul gasket kit.

and coolant tight seal. These gaskets may be metal sheets soft enough to deform as required, but they are usually made in the form of two thin plates of soft metal with a heat-resistant filling between them. Holes are punched in the gasket to conform to the openings in the head and block, which allows the coolant to circulate. If a poorly made or improper gasket is used, the flow of coolant may be restricted, causing troublesome hot spots.

On some engines, especially V-type, the gaskets are so nearly uniform that they can be turned upside down or end for end and still fit the retaining studs and combustion chambers. If they are improperly installed, however, they will stop coolant circulation at some part of the engine. It is important to make sure the correct gasket is used and that the side marked UP or TOP is facing away from the block. If no markings are found, the first surface of the gasket is placed against the block.

The intake and exhaust manifold gaskets are usually made from asbestos formed to the desired shape. Some are metal covered and similar in construction to a head gasket. Because of the heat of the exhaust and intake air, it is necessary that manifold gaskets be made from a material that will not burn.

The oil pan gasket is generally made from pressed cork. It may be made in one piece but more often it is made in two pieces—one piece for each side of the pan. Each end of the pan is sealed with cork or neoprene gasket material.

The other gaskets for an engine are usually cut from pressed paper that is oil resistant. The thickness of the paper varies in accordance with manufacturer's recommendations. Often the gaskets used will create specified clearances between stationary parts of an engine.

When you install any gasket in an engine, it is important for the surfaces to be sealed and to be clean and free from grit and parts of the old gasket. A putty knife is useful for cleaning gasket surfaces. You must be sure the gasket is in the proper position and does not slip when the two parts are brought together. Heavy grease or a gasket compound will help you make sure the gaskets stay in place and form a good seal.

Seals

As explained above, gaskets prevent leaks between stationary parts. As these gaskets are not made to withstand movement of the engine components, you

have to use something to prevent loss of liquids as the engine operates. Seals or O-rings are used to seal the clearances between the moving and stationary parts and the outside of the engine.

Seals manufactured today are too numerous in design to attempt coverage of each particular design in this text. We will mention the more common types and their use only. Most seals you will become familiar with are made of neoprene rubber, molded or crimped to a metal backing. These are known as lip-type seals. The metal seals the outside diameter of the hole it is used in by a press fit. The neoprene, which is flexible and gives a snug fit around the moving part, seals the inside to prevent leakage.

O-rings, another type of seal, are used primarily in places where the clearance is considerably smaller than with lip-type seals. As the parts are installed, the O-ring is squeezed to form a tight seal.

On most gas and diesel engines, the rear main seal is a two-piece strip of molded neoprene rubber, which is squeezed around the rear of the crankshaft between the engine block and rear main bearing cap. This seal works in the same manner as the O-ring.

As you gain experience in the mechanical field, you will be able to recognize the different types of seals and how they work to prevent leaks. In the meantime, if you discover a seal that you have a question about, ask your supervisor. Your supervisor will be able to explain how seals work and why they are made differently.

MOVING PARTS OF AN ENGINE

The moving parts of an engine serve an important function in turning heat energy into mechanical energy. They further convert reciprocal motion into rotary motion. The principal moving parts are the piston assembly, connecting rods, crankshaft assembly (including flywheel and vibration dampener), camshaft, valves, and gear train.

The burning of the fuel-air mixture within the cylinder exerts a pressure on the piston, thus pushing it down in the cylinder. The action of the connecting rod and crankshaft converts this downward motion to a rotary motion.

Piston Assembly

Engine pistons serve a number of purposes. They transmit the force of combustion to the crankshaft through the connecting rod; they act as a guide for the upper end of the connecting rod; and they serve as a

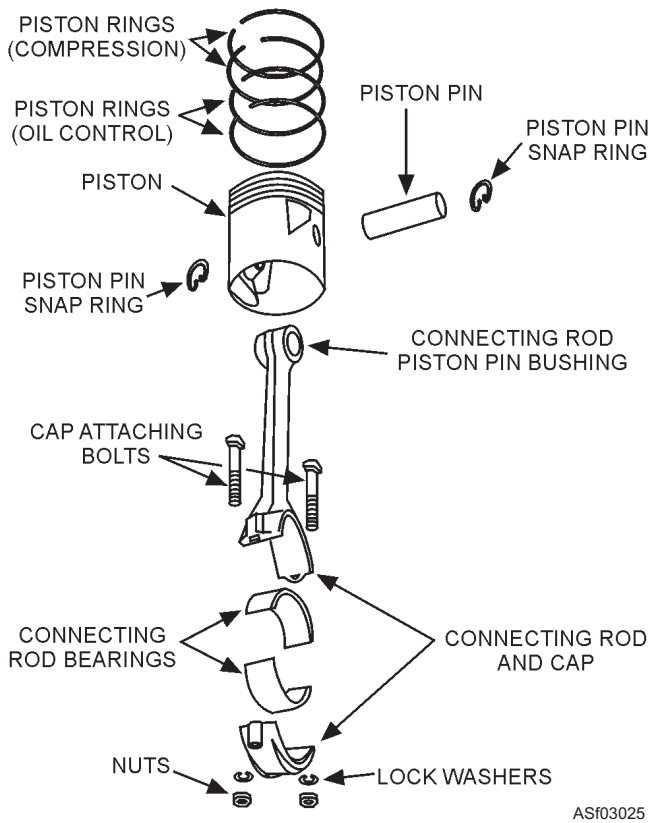

Figure 3-25.—Piston and connecting rod (exploded view).

carrier for the piston rings used to seal the compression in the cylinder. (See fig. 3-25.) Some pistons are designed to cause turbulence in the cylinder in order to mix the air and fuel more efficiently.

The piston must come to a complete stop at the end of each stroke before reversing its course in the cylinder. To withstand this rugged treatment and wear, it must be made of tough material, yet be light in weight. To overcome inertia and momentum at high speeds, it must be carefully balanced and weighed. All the pistons used in any one engine must be of similar weight to avoid excessive vibration.

Pistons are made of gray cast iron or of aluminum alloy. The former is the heavier and is often used in slower, heavy-duty engines; the latter is of lighter weight and is more adaptable to the modern, high-speed engine. To reduce weight, the head and skirt of the piston are made as thin as is consistent with the strength required. Ribs are an integral part of the piston, and they reinforce the head. The ribs also assist in conducting heat from the head of the piston to the piston rings and out through the cylinder walls.

The structural components of the piston are the head, skirt, ring grooves, and lands (fig. 3-26). However, all pistons do not look like the typical one illustrated here. Some have differently shaped heads. Diesel engine pistons usually have more ring grooves

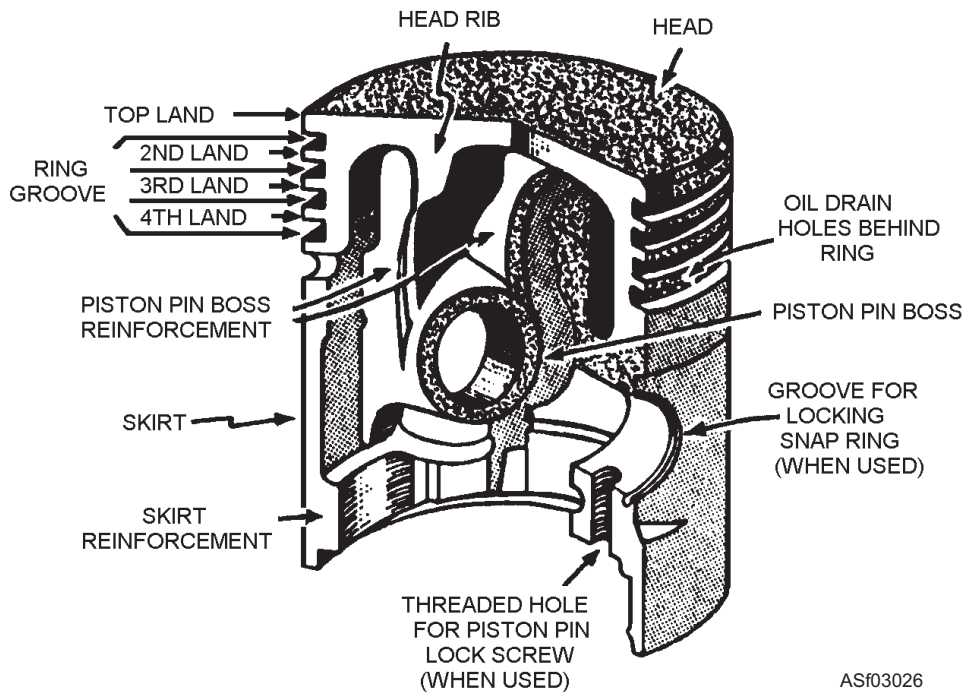

Figure 3-26.—The parts of a piston.

and rings than the pistons of gasoline engines. Some of these rings may be installed below as well as above the wrist or piston pin (fig. 3-27).

Fitting pistons properly is important. Because metal expands when heated, and because space must be provided for lubricants between the pistons and the cylinder walls, the pistons are fitted to the engine with a specified clearance. This clearance depends upon the size or diameter of the piston and the material from which it is made. Cast iron does not expand as fast or as much as aluminum. Aluminum pistons require more clearance to prevent binding or seizing when the engine gets hot. The skirt or bottom part of the piston runs much cooler than the top; therefore, it does not require as much clearance as the head.

The piston is kept in alignment by the skirt, which is usually cam ground (elliptical in cross section), as indicated in figure 3-28. This elliptical shape permits the piston to fit the cylinder, regardless of whether the piston is cold or at operating temperature. The narrowest diameter of the piston is at the piston pin bosses, where the metal is thickest. At the widest diameter of the piston, the piston skirt is thinnest. The piston is fitted to close limits at its widest diameter so that piston noise (slap) is prevented during engine warm-up. As the piston is expanded by the heat

generated during operation, it becomes round because the expansion is proportional to the thickness of the metal. The walls of the skirt are cut away as much as possible to reduce weight and to prevent excessive expansion during engine operation. Many aluminum pistons are made with split skirts so that when the pistons expand the skirt diameter will not increase.

Two types of piston skirts found in most engines are the full trunk and the slipper. The full-trunk type skirt has a full cylindrical shape with bearing surfaces parallel to those of the cylinder, giving more strength and better control of the oil film. The slipper-type (cutaway) skirt has considerable relief on the sides of the skirt, providing clearance for crankshaft counterweights and leaving less area for possible contact with the cylinder walls, and thereby reducing friction.

PISTON PINS.—The piston is attached to the connecting rod by means of the piston pin (wrist pin). The pin passes through the piston pin bosses and through the upper end of the connecting rod, which rides within the piston on the middle of the pin. Piston pins are made of alloy steel with a precision finish and are case hardened and sometimes chromium-plated to increase their wearing qualities. Their tubular construction gives them a maximum of strength with a

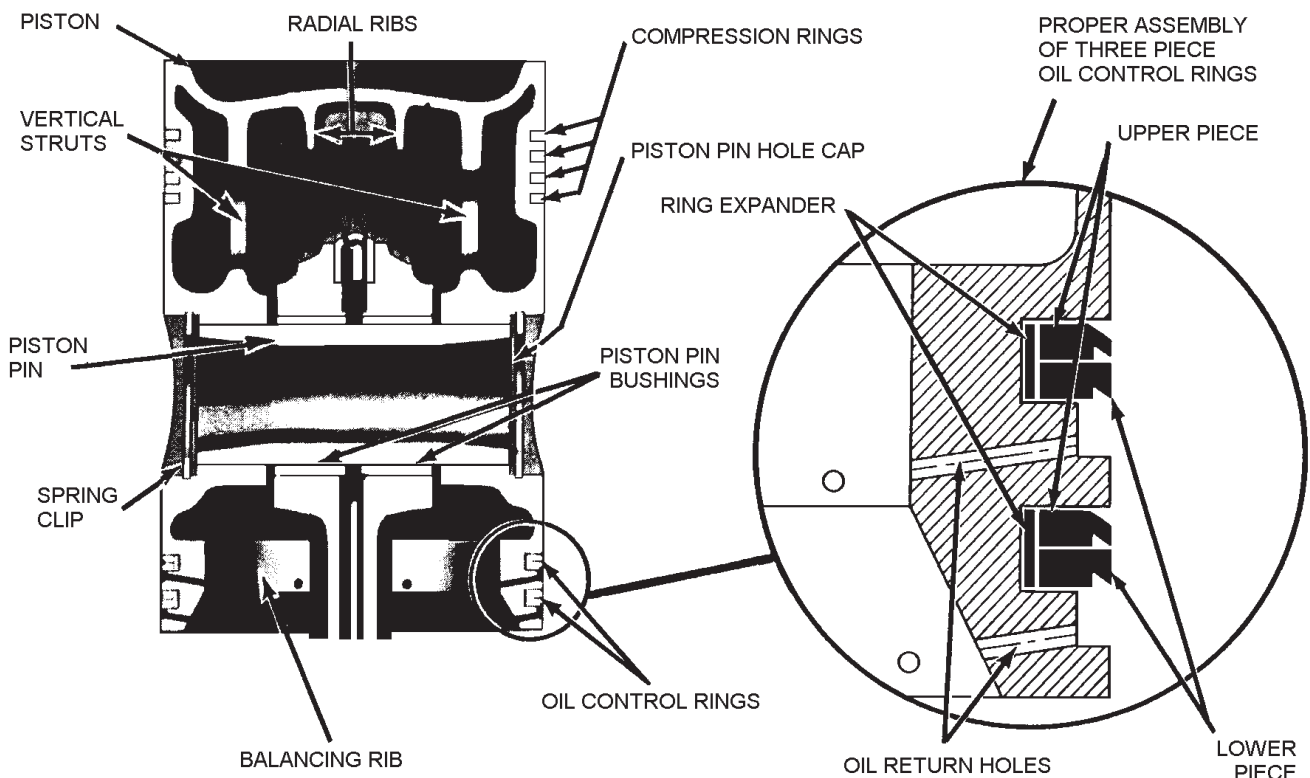

Figure 3-27.—Piston assembly of General Motors series 71 diesel engine.

AS103027

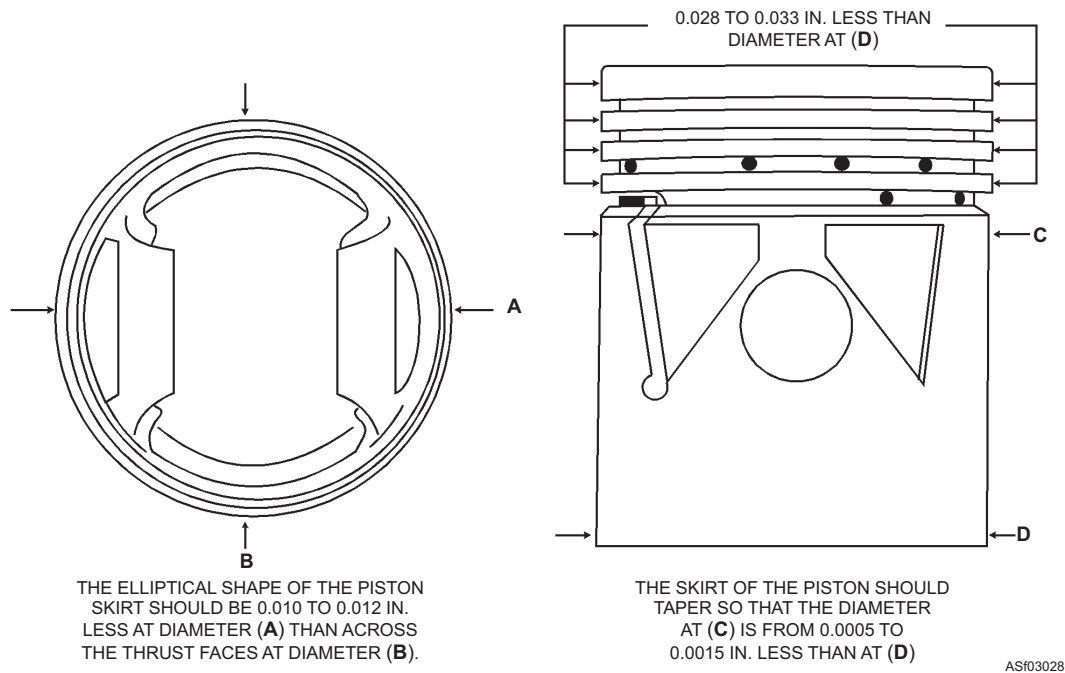

Figure 3-28.—Cam-ground piston.

minimum of weight. They are lubricated by splash from the crankcase or by pressure through passages bored in the connecting rods.

There are three methods commonly used for fastening a piston pin to the piston and the connecting rod. (See fig. 3-29.) An anchored, or fixed, pin is attached to the piston by a screw running through one of the bosses; the connecting rod oscillates on the pin. A semifloating pin is anchored to the connecting rod and turns in the piston pin bosses. A full-floating pin is free to rotate in the connecting rod and in the bosses, but is

prevented from working out against the sides of the cylinder by plugs or snap ring locks.

PISTON RINGS.—Piston rings are used on the pistons to maintain gastight seals between the pistons and cylinders, to assist in cooling the piston, and to control cylinder-wall lubrication. About one-third of the heat absorbed by the piston passes through rings to the cylinder wall. Although piston rings have been made from many materials, cast iron has proved the most satisfactory, as it withstands heat, forms a good wearing surface, and retains a great amount of its

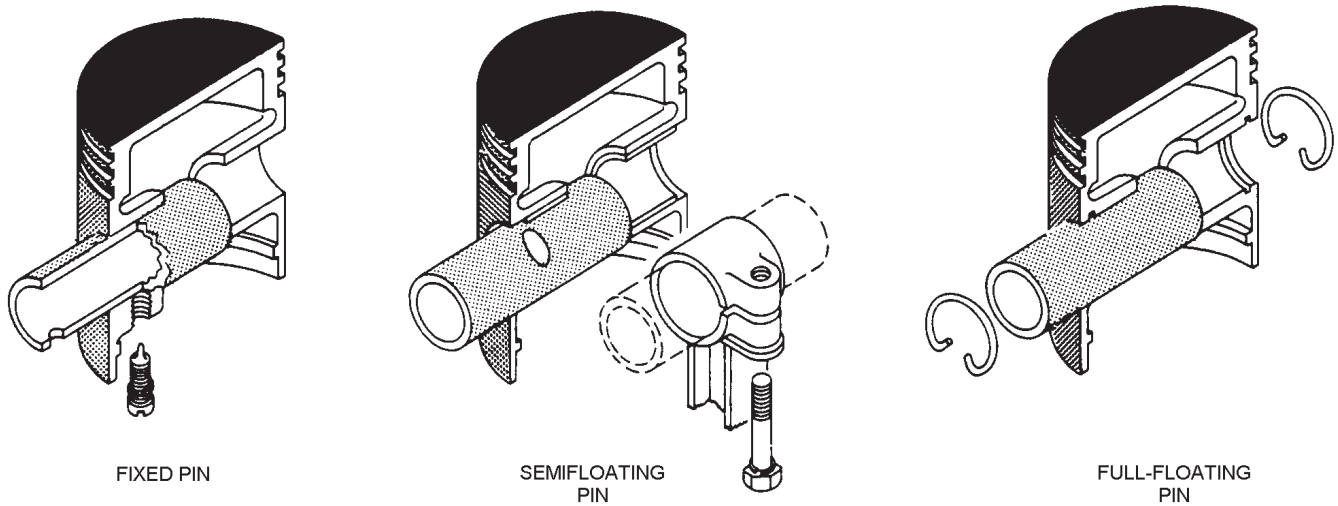

Figure 3-29.—Piston pin types.

elasticity after considerable use. Piston rings are often quite complicated in design, are heat treated in various ways, and are plated with other metals. There are two distinct classifications of piston rings: compression rings and oil control rings (fig. 3-30).

The principal function of a compression ring is to seal in the fuel-air mixture as it is compressed and also seal in the combustion pressures as the mixture burns during the compression and power strokes. All piston rings are split to permit assembly to the piston and to allow for expansion. When the ring is in place, the ends of the split joint do not form a perfect seal; therefore, it is necessary to use more than one ring and to stagger the joints around the piston. If cylinders are worn, expanders are sometimes used to ensure a perfect seal. (See figs. 3-27 and 3-30.)

The bottom ring, usually located just above the piston pin, is an oil-regulating ring. This ring scrapes the excess oil from the cylinder walls and returns some of it, through slots, to the piston ring grooves. The ring groove under an oil ring is provided with openings through which the oil flows back into the crankcase. In some engines, additional oil rings are used in the piston skirt below the piston pin.

Prior to installing a new ring, the ring end clearance must be checked. To check the clearance, first push the ring about 2 inches into the cylinder. Then, using an

upside down piston, push the ring to about 1 inch from the bottom of the cylinder. Remove the piston and use a feeler gauge to check the clearance. If the clearance is too large, oversized rings are required. If the clearance is too narrow, remove the ring and file the ends until the clearance is correct. To file the ring, first place a file in a bench vise; then hold the ring with both hands and compress the gap while filing. This should ensure the squareness of the clearance. File only a small amount at a time, checking your clearance often. If you remove too much at one time, the ring is unusable. Clearances are specified in the manufacturer's manual and should be carefully adhered to.

Rings must be fitted also for the proper side clearance (fig. 3-31). This clearance will vary in different types and makes of engines; however, in the diesel engine, these rings must be given a greater clearance than in the gasoline engine. If too much side clearance is given the rings, excessive wear on the lands will result. If there is too little side clearance, expansion may cause the lands to break.

Connecting Rods

Connecting rods must be light and yet strong enough to transmit the thrust of the pistons to the

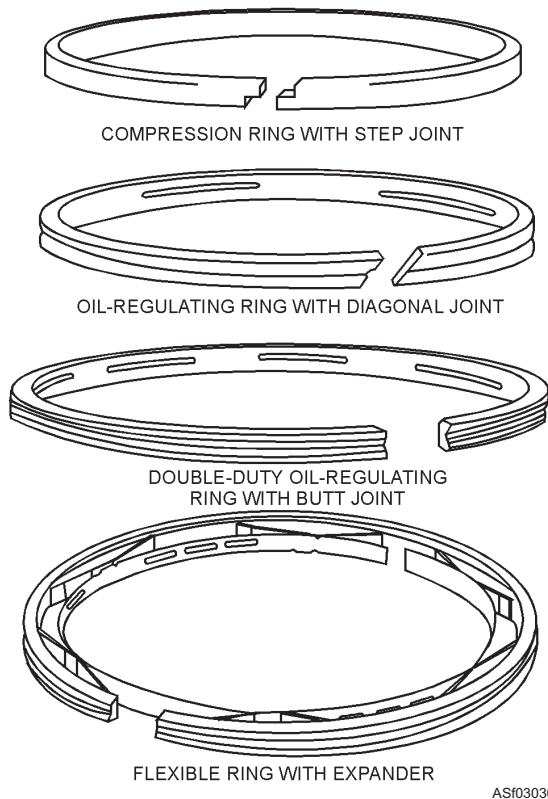

Figure 3-30.—Piston rings.

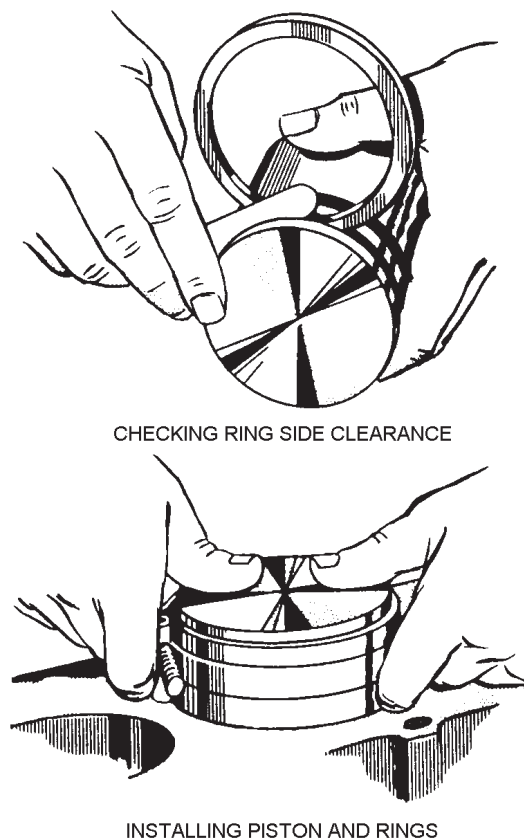

Figure 3-31.—Fitting piston ring and installing piston.

crankshaft. Connecting rods are drop forged from a steel alloy capable of withstanding heavy loads without bending or twisting. Holes at the upper and lower ends are machined to permit accurate fittings of bearings. These holes must be parallel.

The upper end of the connecting rod is connected to the piston by the piston pin. If the piston pin is locked in the piston pin bosses, or if it floats in both piston and connecting rod, the upper hole of the connecting rod will have a solid bearing (bushing) of bronze or similar material. As the lower end of the connecting rod revolves with the crankshaft, the upper end is forced to turn back and forth on the piston pin. Although this movement is slight, the bushing is necessary because the temperatures and the pressures are high. If the piston pin is semifloating, a bushing is not needed.

The lower hole in the connecting rod is split to permit it to be clamped around the crankshaft. The bottom part, or cap, is made of the same material as the rod and is attached by two or more bolts. The surface that bears on the crankshaft is generally a bearing material in the form of a separate split shell, although, in a few cases, it may be spun or die-cast in the inside of the rod and cap during manufacture. The two parts of the separate bearing are positioned in the rod and cap by dowel pins, projections, or short brass screws. The shell may be of babbitt metal that is die-cast on a backing of bronze or steel. Split bearings may be of the precision or semiprecision type.

The precision type bearing is accurately finished to fit the journal and does not require further fitting during installation. It is positioned by projections on the shell, which match reliefs in the rod and cap. The projections prevent the bearings from moving sideways and from rotary motion in the rod and cap.

The semiprecision type bearing is usually fastened to or die-cast with the rod and cap. Prior to installation, it is machined and fitted to the proper inside diameter with cap and rod bolted together.

To maintain good engine balance, connecting rods are carefully matched in sets. When it becomes necessary to remove the connecting rods, make sure they are marked so they can be replaced in the same cylinder from which they were removed. Most rods are marked at the factory, but if they are not, use a number punch to mark them in such a way that you will not get them mixed.

In addition to the proper fit of the connecting rod bearings and the proper position of the connecting rod, the alignment of the rod itself must be considered. That is to say, the hole for the piston pin and the crankpin must be precisely parallel. Equipment of suitable accuracy is available for checking connecting rods. (See fig. 3-32.) Every connecting rod should be checked for proper alignment just before it is installed in the engine. Misalignment of connecting rods will cause many hard-to-locate noises in the engine.

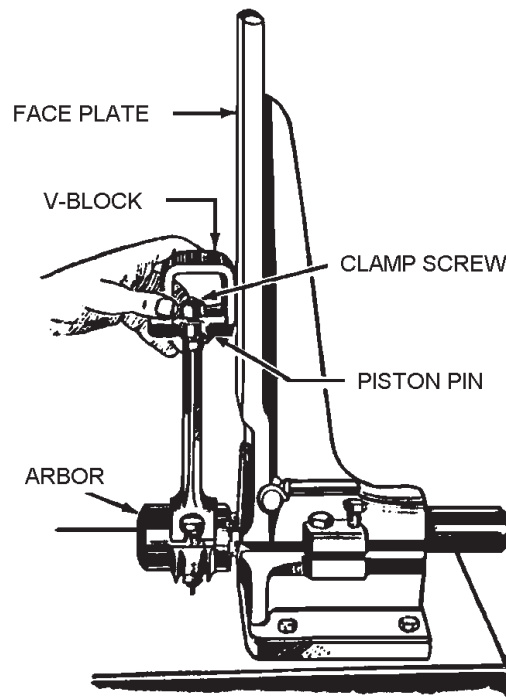

ASf03032

Figure 3-32.—Checking connecting rod alignment.

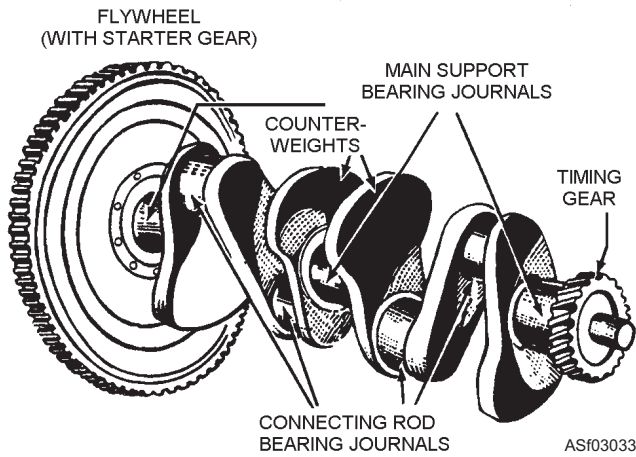

Figure 3-33.—Crankshaft of a 4-cylinder engine.

Crankshaft

As the pistons collectively might be regarded as the heart of the engine, so the crankshaft may be considered its backbone (fig. 3-33). It ties together the reactions of the pistons and the connecting rods, transforming their reciprocating motion into a rotary motion, and transmitting engine power through the

flywheel, clutch, transmission, and differential to drive your vehicle.

The crankshaft is forged or cast from an alloy of steel and nickel, is machined smooth to provide bearing surfaces for the connecting rods and the main bearings, and is casehardened or coated in a furnace with copper alloyed with carbon. These bearing surfaces are called journals. The crankshaft counterweights impede the centrifugal force of the connecting rod assembly attached to the throws or points of bearing support. These throws must be placed so that they counterbalance each other.

Crank throw arrangements for 4-, 6-, and 8-cylinder engines are shown in figure 3-34. Four-cylinder engine crankshafts have either three or five main support bearings and four throws in one plane. In figure 3-34 you see that the throws for No. 1 and No. 4 cylinders (4-cylinder engine) are 180 degrees from those for No. 2 and No. 3 cylinders. On 6-cylinder engine crankshafts, each of the three pairs of throws is arranged 120 degrees from the other two. Such crankshafts may be supported by as many as seven main bearings; that is, one at each end of the shaft and one between each of the crankshaft throws. The crankshafts of 8-cylinder, V-type engines are similar to

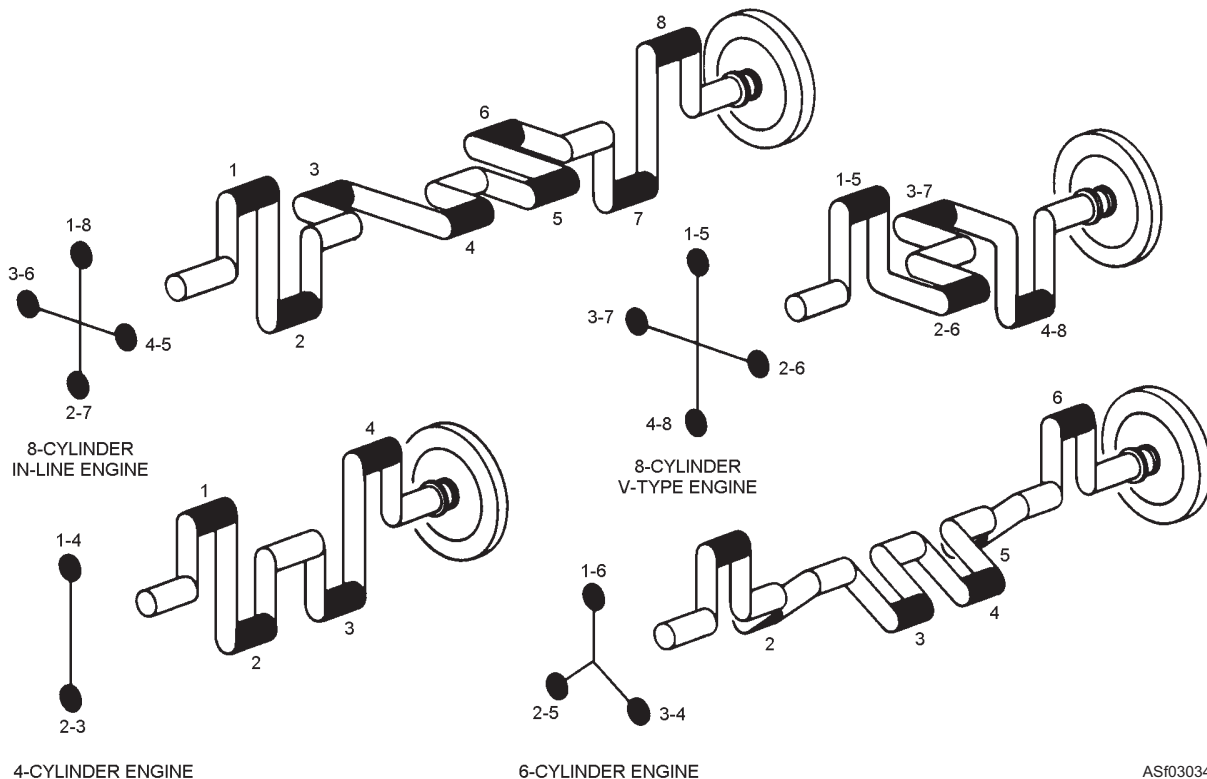

Figure 3-34.—Crankshaft and throw arrangements commonly used.

those for the 4-cylinder inline type or may have each of the four throws fixed at 90 degrees from each other (fig. 3-34) for better balance and smoother operation.

V-type engines usually have two connecting rods fastened side by side on one crankshaft throw. With this arrangement one bank of the engine cylinders is set slightly ahead of the other to allow the two rods to clear each other.

Any piece of rotating machinery has a critical speed at which it will vibrate. Thus, the thrust of power described in the preceding paragraphs creates a torsional or twisting vibration of the crankshaft. Torsional vibration is noticeable in long crankshafts, and unless it is controlled, the crankshaft could break. If you can imagine a rubber tube being twisted by a forceful turn of a wheel to which it is connected, you can visualize a similar characteristic in the crankshaft (only to a much lesser degree) as it begins to turn against the inertia of the flywheel.

The crankshaft rotates in main bearings located at both of its ends and at certain intermediate points. Most crankshaft bearings are precision bearings (prefit) that consist of a hard shell of steel or bronze, with a thin lining of antifrictional metal or bearing alloy. These bearings often are channeled for oil distribution and may be lubricated with crankcase oil by pressure through drilled passages or by splash.

Some main bearings have integral thrust faces that eliminate crankshaft end play. To prevent loss of oil, seals are placed at both ends of the crankshaft where it extends through the crankcase. Similar seals are placed in the channels provided in the upper half of the bearings. When replacing main bearings, tighten the bearing-cap bolts to the proper tension with a torque wrench and lock them with a cotter pin or safety wire after they are in place.

Engine crankshafts are large and expensive; therefore, it is often desirable to repair them rather than replace them. An engine crankshaft is subjected to terrific stresses and it may develop minute cracks. Before extensive repair work is started, check the shaft carefully for cracks, particularly near the ends of the connecting rod throws, near the ends of the main bearing journals, and near the oil feed holes. If the shaft is sound, the bearing journals may be reground and oversize bearings fitted. If the crankshaft is ground down by 10 thousandths of an inch, the new replacement bearing will be a 10 thousandths of an inch oversized bearing.

VIBRATION DAMPER.—The power impulses of an engine tend to set up torsional vibration in the crankshaft. If this torsional vibration were not controlled, the crankshaft might actually break at certain speeds; a vibration damper mounted on the front of the crankshaft is used to control this vibration.

Most types of vibration dampers resemble a miniature clutch. (See fig. 3-35.) A friction facing is mounted between the hub face and a small damper flywheel. The damper flywheel is mounted on the hub face with bolts that go through rubber cones in the flywheel. These cones permit limited circumferential movement between the crankshaft and damper flywheel. This minimizes the effects of the torsional vibration in the crankshaft. Several other types of vibration dampers are used. However, they all operate in essentially the same way.

ENGINE FLYWHEEL.—The flywheel is mounted at the rear of the crankshaft near the rear main bearing. This is usually the longest and heaviest main bearing in the engine, as it must support the weight of the flywheel.

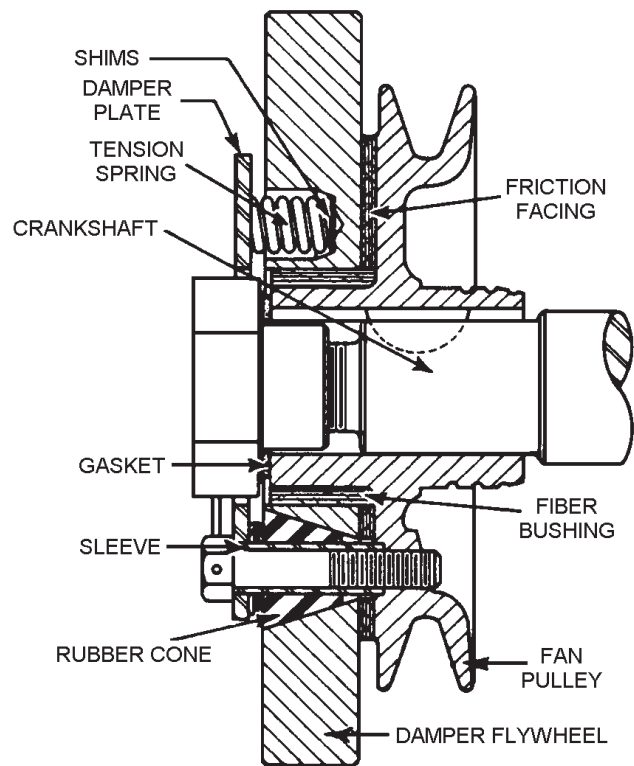

ASf03035

Figure 3-35.—Sectional view of a typical vibration damper.

The flywheel (fig. 3-36) stores up energy of rotation during power impulses of the engine. It releases this energy between power impulses, thus assuring fewer fluctuations in engine speed and smoother engine operation. The size of the flywheel will vary with the number of cylinders and the general construction of the engine. With a large number of cylinders and the consequent overlapping of power impulses, there is less need for a flywheel; consequently, the flywheel can be relatively small. The flywheel rim carries a ring gear, either integral with the flywheel or shrunk on. By heating the ring gear, putting it in place, and then allowing it to cool and contract on the flywheel, the ring gear meshes with the starter driving gear for cranking the engine. The rear face of the flywheel is usually machined and ground, and acts as one of the pressure surfaces for the clutch, becoming a part of the clutch assembly.

Valves and Valve Mechanisms

There are two valves for each cylinder in most engines, one intake and one exhaust valve. Since each of these valves operates at different times, it is necessary that separate operating mechanisms be provided for each valve. Valves are normally held closed by heavy springs and by compression in the combustion chamber. The purpose of the valve-actuating mechanism is to overcome the spring pressure and open the valve at the proper time. The valve-actuating mechanism includes the engine camshaft, camshaft followers (tappets), pushrods, and rocker arms.

CAMSHAFT.—The camshaft (fig. 3-37) is enclosed in the engine block. It has eccentric lobes (cams) ground on it for each valve in the engine. As the camshaft rotates, the cam lobe moves up under the

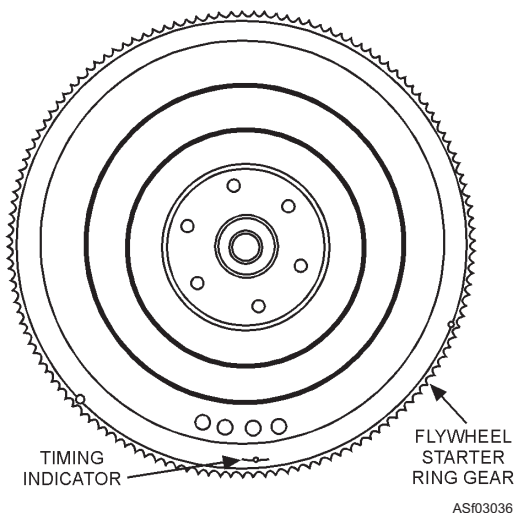

Figure 3-36.—Flywheel.

valve tappet, exerting an upward thrust through the tappet against the valve stem or a pushrod. This thrust overcomes the valve spring pressure as well as the gas pressure in the cylinder, causing the valve to open. When the lobe moves from under the tappet, the valve spring pressure reseats the valve.

On L-, F-, or I-head engines, the camshaft is usually located to one side and above the crankshaft, while in V-type engines, it is usually located directly above the crankshaft. On the overhead camshaft engine, the camshaft is located above the cylinder head.

The camshaft of a 4-stroke cycle engine turns at one-half engine speed. It is driven off the crankshaft through timing gears or a timing chain. In the 2-stroke cycle engine, the camshaft must turn at the same speed as the crankshaft so that each valve will open and close once in each revolution of the engine.

In most cases the camshaft will do more than operate the valve mechanism. It may have external cams or gears that operate fuel pumps, fuel injectors, the ignition distributor, or the lubrication pump.

Camshafts are supported in the engine block by journals in bearings (fig. 3-37). Camshaft bearing journals are the largest machined surfaces on the shaft. The bearings are usually made of bronze and are bushings rather than split bearings. The bushings are lubricated by oil circulating through drilled passages from the crankcase. The stresses on the camshaft are small therefore, the bushings are not adjustable and require little attention. The camshaft bushings are generally replaced only when the engine requires a complete overhaul.

FOLLOWERS.—Camshaft followers are the parts of the valve-actuating mechanism that contact the camshaft. You will probably hear them called valve tappets or valve lifters. In the L-head engine, the followers or tappets directly contact the end of the valve stem and have an adjusting device in them (fig. 3-38).

In the overhead valve engine, the followers or valve tappets contact the pushrod that operates the rocker arm (fig. 3-39). The end of the rocker arm opposite the

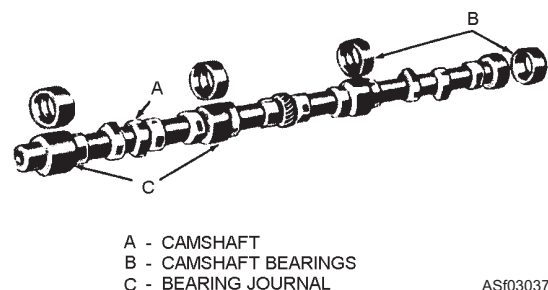
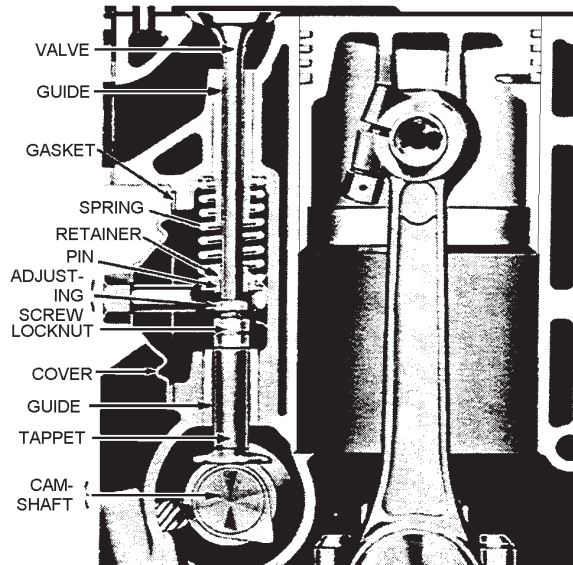
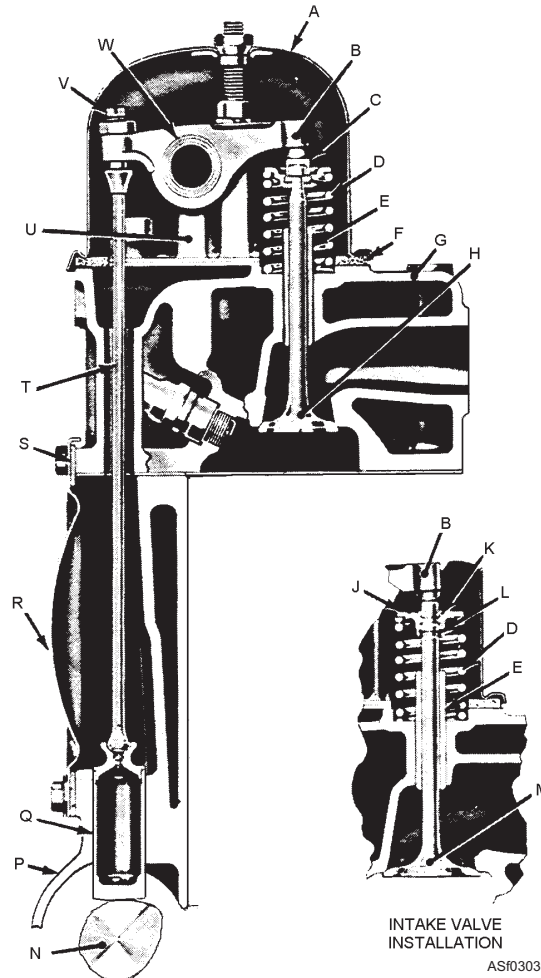

Figure 3-37.—Camshaft and bushings.



ASf03038

Figure 3-38.—L-head valve operating mechanism.



ASf03039

- | | | |
|------------------------|---------------------|-----------------------------|
| A. Cylinder head cover | H. Exhaust valve | Q. Valve tappet |
| B. Rocker arm | J. Valve spring cap | R. Push rod cover |
| C. Rotator cap | K. Intake valve key | S. Gasket |
| D. Valve spring | L. Seal | T. Push rod |
| E. Valve guide | M. Intake valve | U. Rocker arm shaft bracket |
| F. Cover gasket | N. Camshaft | V. Adjusting screw |
| G. Cylinder head | P. Crankcase | W. Rocker arm shaft |

Figure 3-39.—Valve operating mechanism for an overhead valve engine.

pushrod contacts the valve stem. The valve adjusting device, in this case, is in the rocker arm.

Many engines have self-adjusting valve lifters of the hydraulic type that operate at zero clearance at all times. The operation of one type of hydraulic valve tappet mechanism is shown in figure 3-40. Oil under pressure is forced into the tappet when the valve is closed, and this pressure extends the plunger in the tappet so that all valve clearance, or lash, is eliminated. When the cam lobe moves around under the tappet and starts to raise it, there will not be any tappet noise. As the lobe starts to raise the tappet, the oil is forced upward in the lower chamber of the tappet. This action closes the ball check valve so oil cannot escape. Then, the tappet acts as though it were a simple, one-piece tappet and the valve is opened. When the lobe moves out from under the tappet and the valve closes, the pressure in the lower chamber of the tappet is relieved. Any slight loss of oil from the lower chamber is then replaced by the oil pressure from the engine lubricating system. This causes the plunger to move up snugly against the pushrod so that any clearance is eliminated.

ADJUSTING VALVE OPERATING MECHANISMS.—The intake and exhaust valves are operated by rocker arms and pushrod assemblies working off the engine camshaft. In some engines, the camshaft acts directly on the rocker arm to open the valves. In all cases, it is important that the proper clearance (valve lash) be maintained in the linkage to compensate for expansion as the engine heats up. Too much clearance causes noise. Also, the valves do not remain open long enough. Too little clearance prevents proper seating and causes burned and leaky valves.

The adjustment of valve clearances can generally be changed by an adjustment screw in the rocker arm or by a threaded part of the pushrod (fig. 3-41). A locknut is provided with either device. The manufacturer's manual gives you the proper setting and the valve adjustment procedures.

HYDRAULICALLY OPERATED VALVE ADJUSTMENT.—On engines equipped with hydraulic valve lifters (fig. 3-42), it is not generally necessary to adjust the valves. They operate with zero clearance (fig. 3-40). The engine lubrication system supplies a flow of oil to the lifters at all times. Hydraulic lifters compensate for changes in engine temperature, adapt automatically for minor wear at various points, and thus provide ideal valve timing.

If for any reason the valve mechanism must be repaired, an initial adjustment must be made after reassembling the job. Almost all manufacturers have a different procedure for making this adjustment, so check the manufacturer's service guide for the engine concerned.

HYDRAULIC VALVE LIFTER SERVICE.—Hydraulic valve lifters are comparatively simple in design. Servicing the lifters requires only that care and cleanliness be exercised when handling parts.

The first indication of a faulty lifter is that it starts making a "clicking" noise. A listening rod or an engine stethoscope is helpful in locating a noisy valve lifter. You do this by placing one end of the tool against the particular part of the engine and the other part to your ear. Move the instrument around the engine until you have narrowed the noise down to a certain area. In an

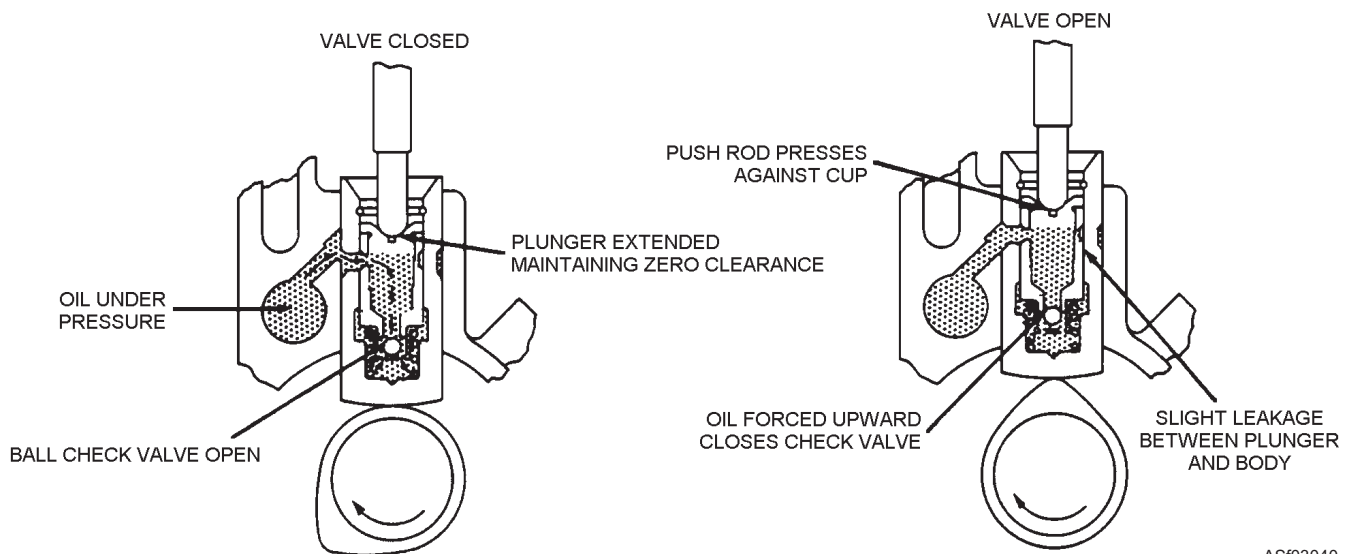
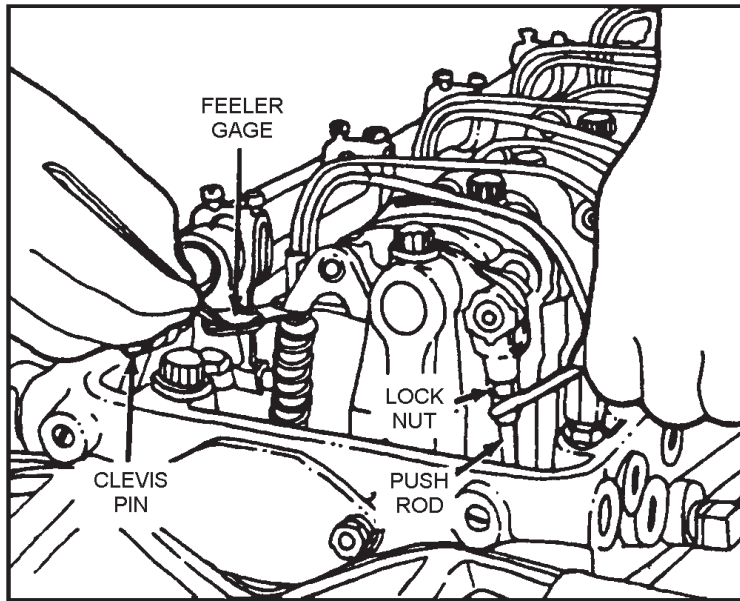

Figure 3-40.—Operation of a hydraulic valve tappet or lifter.

ASf03040



ASf03041

Figure 3-41.—Adjusting valve clearance.

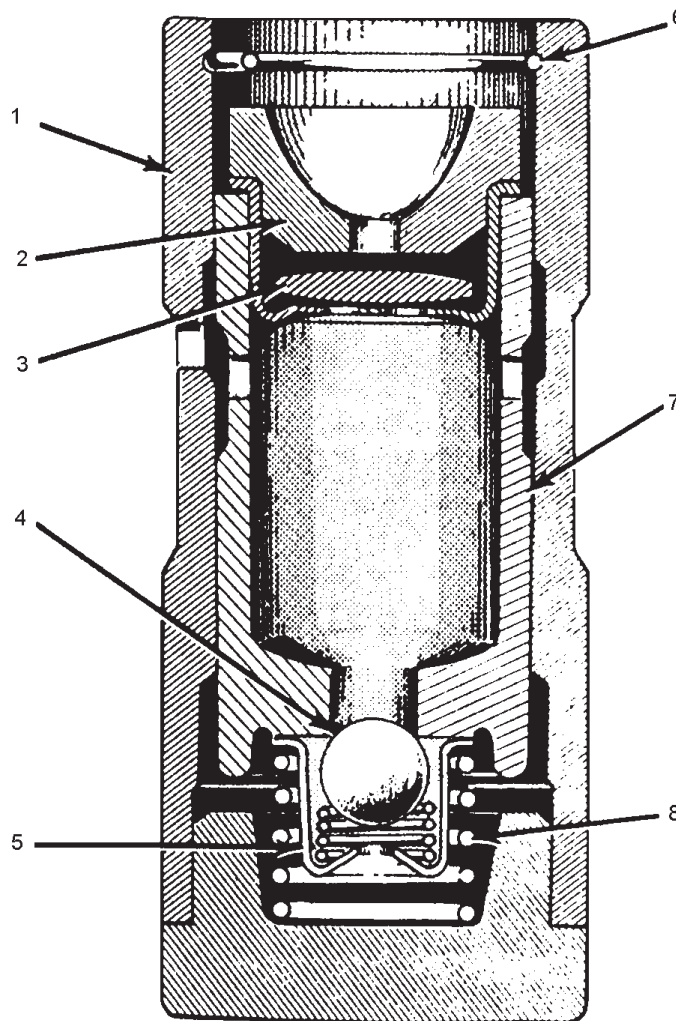

ASf03042

- 1. Lifter body
- 2. Push rod seat

- 3. Inertia valve
- 4. Check ball

- 5. Ball retainers
- 6. Push rod seat retainers

- 7. Plunger
- 8. Plunger spring

Figure 3-42.—Hydraulic valve lifter.

emergency, you can use a long screwdriver or a piece of garden hose. You should always be careful of the moving fan belt and fan blade.

Usually, where noise exists in one or more of the valve lifters, all lifter units should be removed, cleaned in a solvent, reassembled, and reinstalled in the engine. If dirt, carbon, or the like, is present in one unit, it is more than likely present in all of them; and it is only a matter of time before the other lifter units will cause trouble.

Parts of hydraulic valve lifters are not interchangeable. Should one part become damaged, it is necessary to replace the whole unit. The plunger must be free to move in the lifter body. A simple test for this is to be sure that the plunger will drop of its own weight in the body.

ENGINE VALVES AND VALVE SEATS.—Most engines have poppet valves (also called mushroom or tulip valves). The word "poppet" comes from the popping action of the valve; "mushroom" and "tulip" come from the shape of the valve. The intake valves are ordinarily made of chromium-nickel alloy. The exhaust valves are generally made of silichrome alloy because of the extremely high temperatures they must withstand. Sometimes exhaust valves contain sodium in a sealed cavity extending from head to stem. This sodium cools the valves by conducting heat away from it.

Both the intake and the exhaust valves operate against the rims of circular openings (valve ports) in the combustion chambers of the cylinders. These rims are called valve seats (fig. 3-43). The valve and valve seat must make perfect contact. Although some earlier engines were designed with flat contact surfaces for the valve and valve seat, most are now designed with valve seat angles of 30 to 45 degrees, as shown in figure 3-43. This angle helps prevent excessive accumulation of carbon on the contact surface of the seat, a condition that keeps the valve from closing properly. To further reduce carbon buildup, an interference angle, usually 1 degree between the valve and seat, is used on some

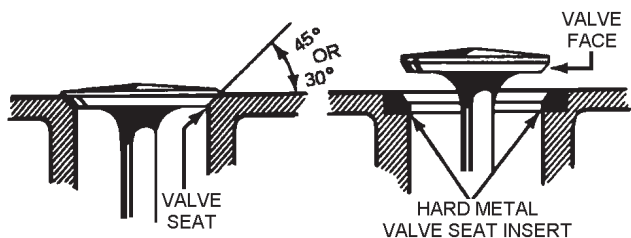

ASf03043

Figure 3-43.—Valve head and set angle.

engines. Carbon deposits, incidentally, tend to pit the softer metal of the cylinder block and head.

Many engines have replaceable valve seat inserts (fig. 3-44) made of special heat-resistant alloys. These inserts can be used in either cast-iron or aluminum blocks or heads. When a valve seat insert is badly worn from grinding or pitting, it must be replaced.

RECONDITIONING VALVES AND VALVE SEATS.—Valve reconditioning includes grinding valves and valve seats, adjusting valve tappet clearances, installing new seat inserts, and timing the valves. Together, these operations constitute the valve service necessary for smooth engine performance and maximum power output.

"Grinding valves" is a common expression used around the shop. It is the major, but not the only, operation in reconditioning them. Before valves are ground or refaced on the valve-refacing machine, they must be cleaned. Heavy carbon deposits and excessively burned valves may indicate the need for new rings or valve guides and/or intake valve oil seals. Carbon deposits and burned valves may also indicate improper combustion resulting from poor spark ignition in the gasoline engine or improper fuel injection in the diesel engine.

To recondition valves and valve seats, first take off the cylinder head and remove the carbon from the head, cylinder block, and pistons. In cleaning the top of the pistons, you must exercise care to prevent gouging and scratching, as rough spots collect carbon readily and will lead to preignition and detonation during engine operation. Remove the valves by using a valve spring

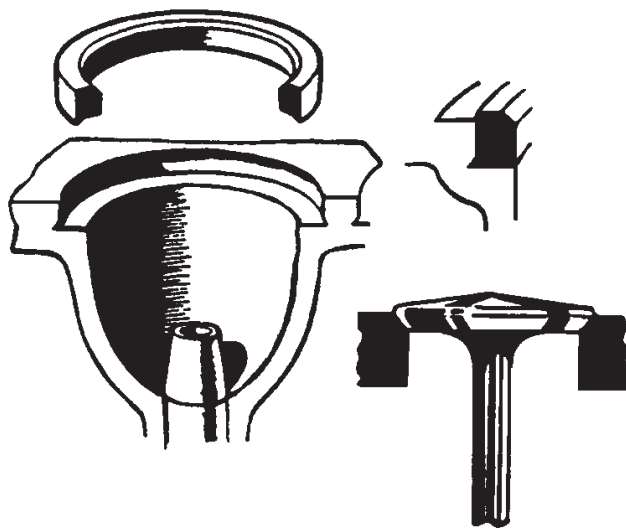

ASf03044

Figure 3-44.—Valve seat insert.

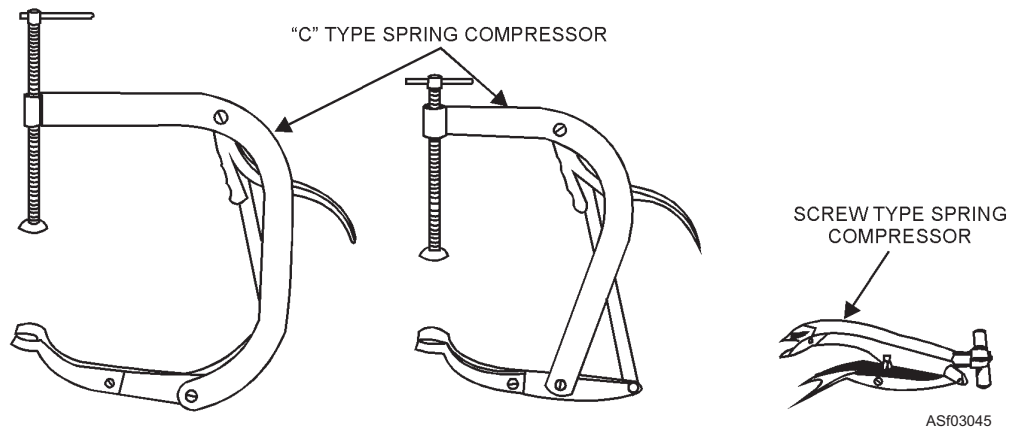

Figure 3-45.—Valve spring compressors for L-head and valve-in-head engines.

compressor (fig. 3-45). Next, clean the valves with a wire brush or buffing wheel (fig. 3-46). When using the buffing wheel, make sure you wear proper eye protection to prevent wire and other foreign matter from flying into your eyes.

Be careful not to interchange the valves. Each valve must be replaced in the same valve port from which it was removed. The valve stem moving up and down in the valve guide develops a wear pattern. And, if the valves are interchanged, a new wear pattern is developed, causing excessive wear on the valve stem and guide.

To eliminate any confusion, you should devise some system of marking the valves to identify them with the cylinders from which they were taken. The most common way to identify valves is to place them in a piece of board with holes drilled and numbered to correspond with the cylinder the valves came from. If any valves are found to be worn or damaged beyond use during inspection, replace them with new ones from the parts room.

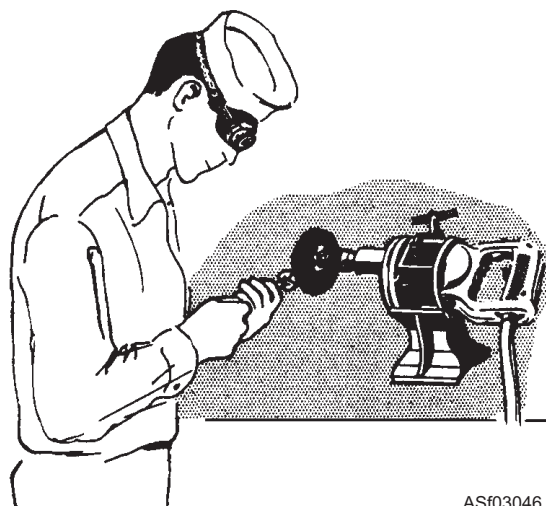

Figure 3-46.—Cleaning a valve with a wire buffing wheel.

After you have cleaned the valves, remove the carbon from the intake and exhaust valve ports. Inspect closely around the valve ports and cylinders of the block for cracks and faulty valve seats. Should cracks be found, check with your supervisor for the proper procedure to follow. After you inspect the cylinder head for cracks, check the head for warpage, using a straightedge and a thickness gauge. The water passages inside the head should be cleaned if an excessive buildup of scale and rust is found. The easiest method is to remove the core plugs and boil the head in a cleaning solution. The alternate method is to scrape the unwanted material loose and then flush with water, air, or a combination of both. After a thorough inspection of the parts, the next step is to resurface the valve face with a valve refacing machine (fig. 3-47). Clamp the valve stem in the chuck of the refacing machine. Be sure the grinding angle index is set to the angle of the valve head you are about to grind. Follow the operating instructions of the manufacturer of the refacing

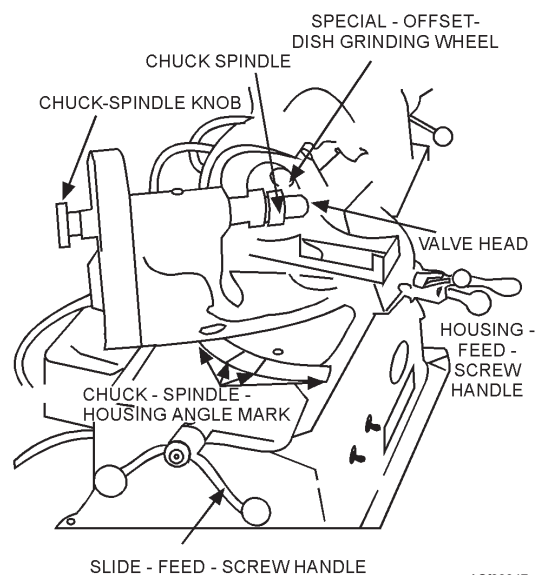

Figure 3-47.—Valve refacing machine.

machine together with those of your supervisor until you are familiar with the details of grinding.

If the tip ends of the valve stems are rough, smooth them by grinding lightly with a special attachment furnished with the valve refacing machine.

Before the valve seats are serviced, the valve guides must be serviced and replaced if necessary.

VALVE GUIDE SERVICE.—Servicing of valve guides is an important, but often neglected, part of a valve job. The guide must be clean and in good condition before a good valve seat can be made. Wear of valve guides is generally the only trouble you will encounter with them.

There are several satisfactory methods of checking for valve guide wear. One procedure for flathead guide service includes the use of a dial indicator. With the valve in place, turn the engine so the valve is moved off its seat. Install the dial indicator on the block with indicating button touching the edge of the valve head. Move the valve sideways to determine the amount of wear. Another checking procedure involves the use of a small hole gauge to measure the inside of the guide and a micrometer to measure the valve stem; the difference in the readings will be the clearance. Check the

manufacturer's manual for the allowable maximum clearance. When the maximum clearance is exceeded, the valve guide will need further servicing before you proceed with the rest of the valve job.

Servicing procedures will depend on whether the guide is of the integral or the replaceable type. If of the integral type, it must be reamed to a larger size and a valve with an oversize stem installed. But if it is of the replaceable type, it should be removed and a new guide installed.

Knurling of the valve guides has become more popular as a method of compensating for wear of the valve guides. Knurling is accomplished by inserting a special tool in the worn guide attached to an electric drill. This method is not recommended if the guide has been worn excessively or previously knurled.

Valve guides should be removed and replaced with special drivers. When working on a valve-in-head engine, you may use an arbor press to remove and replace valve guides.

After the valve guides are serviced and the valve seats are ground, check the concentricity of the two with a valve seat dial indicator (fig. 3-48). Any irregularity in the seat will register on this dial.

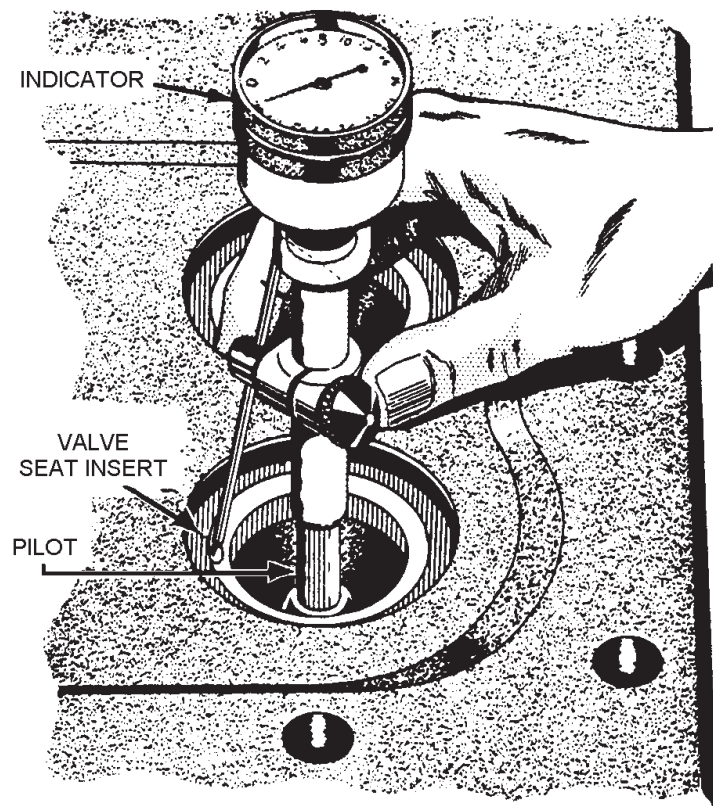

ASf03048

Figure 3-48.—Using a valve seat dial gauge.

VALVE SEAT SERVICE.—If a replaceable seat is badly worn or ground down, replace it with a new one. Remove the old seat either with a puller or by drilling it on two opposite sides, and then breaking it in halves with hammer and chisel. New inserts should be chilled in dry ice for about 15 minutes to shrink them so they can easily be driven into place.

In most cases, the valve seats are not replaceable, so they must be ground. Figures 3-49 through 3-51 illustrate the equipment used in valve seat grinding. Be sure you know how to operate the kind of equipment that is in your shop. Study the manufacturer's manual for specific instructions.

Select the proper size pilot (fig. 3-50) for the valve guide and insert and lock it into the guide. Wipe the valve seat free of carbon dust and oil. Then, with a clean oily rag, apply a thin film of oil to the pilot shaft.

Use two or more stone sleeves (fig. 3-51) to facilitate seat grinding if the engine block has both soft and hard seats or if a high-polish finish grind is desired. One sleeve may carry a soft seat stone, another a hard seat stone, and a third sleeve a finishing stone.

All purpose stones are now available that will do all of the above grinding jobs with one stone. Make sure the stones are dressed at the proper angle in accordance with the engine manufacturer's specifications.

Only a few seconds are required to recondition the average valve seat. Check the progress of the grinding



ASf03050

Figure 3-50.—Self-centering valve guide pilot.

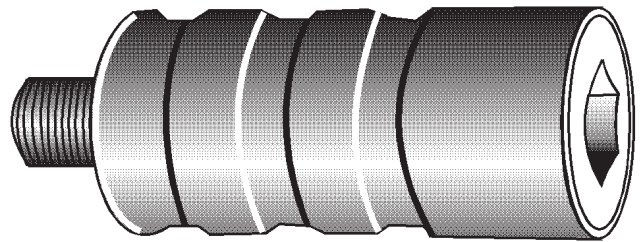

ASf03051

Figure 3-51.—Valve seat grinding stone sleeve.

operation often and make sure that you do not remove any more material than is necessary to get a good seat.

Although recommended, it is usually not necessary to lap the contact surfaces of the valve and valve seat after they have been ground. Always check your work by testing one or two of the valves. This check can be made by spreading a thin coat of Prussian blue on the valve face or by putting lead pencil marks on the valve seat. If, when turning a valve on its seat, an even deposit of the coloring is seen on the valve seat, or the pencil lines are removed, the seating is perfect. The valve should not be rotated more than 1/8 turn, as a high spot could give a false indication if turned one full revolution.

Figure 3-52 shows a normal valve seat, which will vary according to the manufacturer's specification.

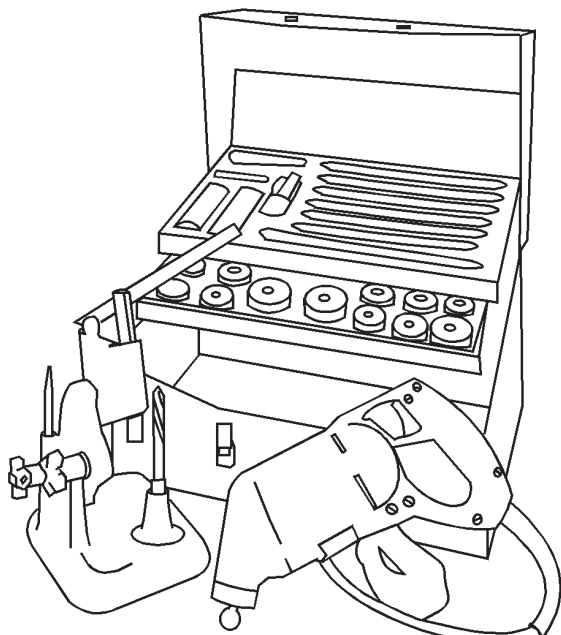

ASf03049

Figure 3-49.—Valve seat grinding equipment.

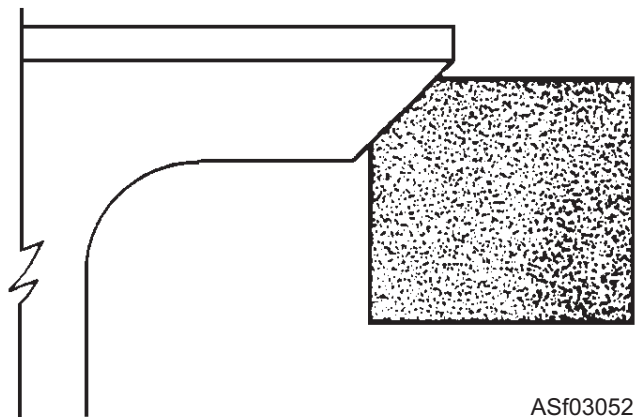

ASf03052

Figure 3-52.—Normal valve seat.

When a great deal of grinding is necessary on a badly burned or worn seat, a condition such as that shown in figure 3-53 will occur. When this happens, you should narrow and center the valve seat by using a 20 degree stone to cut down the upper portion of the valve seat, and a 70 degree stone to cut down the lower portion of the seat. Figure 3-54 illustrates a valve seat that has been narrowed down from the top of the valve seat. Grinding with the narrowing stones usually requires only a few seconds. Check often while grinding so that you will not remove too much metal.

CHECKING ROCKER ARMS.—After rocker arms have been removed, they should be inspected for wear or damage. Rocker arms with bushings can be rebushed if the old bushing is worn. On some rocker arms, the valve ends, if worn, can be ground down on the valve refacing machine. Excessively worn rocker arms should be discarded.

The silent lash rocker arm can be disassembled by removing the eccentric retaining pin. If more than one rocker arm is being disassembled, do not mix the parts; make sure all parts go back into the rocker arms from which they were taken. When reassembling a rocker arm, make sure the eccentric is installed so that the recessed dot (which is on the side with the smaller radius) is next to the plunger.

When reinstalling rocker arms and shafts in the cylinder head, make sure that the oil holes (in shafts so equipped) are on the underside so they will feed oil to the rocker arms. Be sure that all springs and rocker arms are restored to their original positions as the shafts are attached to the head.

CHECKING VALVE SPRINGS.—While working with valves, you may notice that some of them have more than one spring. These additional springs are coiled to offset a tendency of the valve to vibrate at high

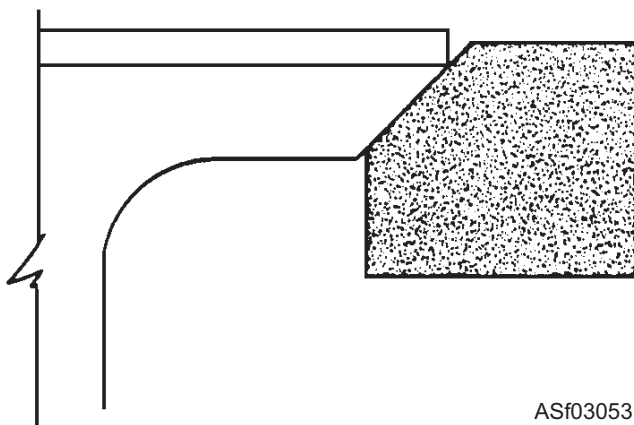

ASf03053

Figure 3-53.—Valve seat too wide and low in block.

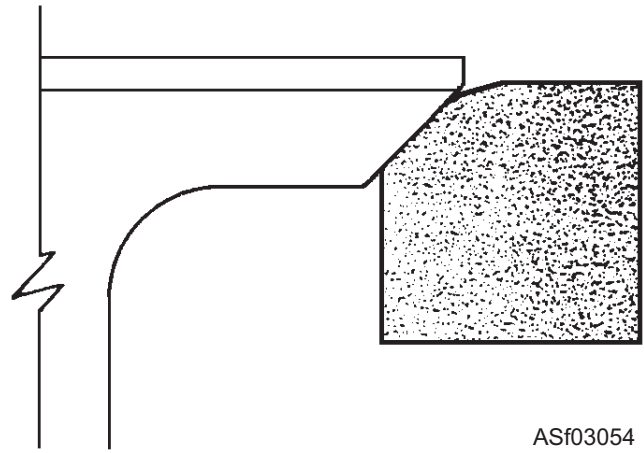

ASf03054

Figure 3-54.—Correct valve seat after narrowing seat.

engine speeds. They also ensure proper valve seating and provide a safety factor in case one spring should break.

Test valve springs for uniformity and strength. For an accurate test, use a valve spring tester (fig. 3-55) when one is available. If a valve spring tester is not available, place used springs on a level surface beside a pair of new springs. Use any straightedge to determine irregularities in height. Replace worn out springs with new ones. Unequal or cocked valve springs will offset, in the assembled job, all the precision that has been put into the grinding operation.

When you have reassembled an engine after reconditioning the valves, make sure the adjusting screws are backed off before rotating the engine. A valve that is too tight could strike and damage the piston or the valve, or both.

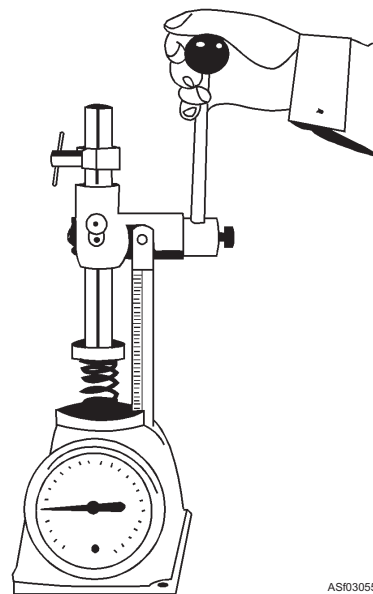

ASf03055

Figure 3-55.—Valve spring tester.

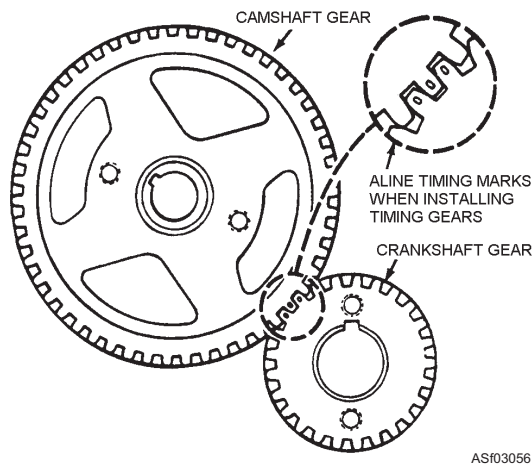

Figure 3-56.—Timing gears and their markings.

Following the recommended procedure, adjust the valves to meet the manufacturer's specification. Never attempt to adjust valves with solid lifters by "ear." If, after adjusting the valves with a gauge, there is still excessive valve-lash noise, do not attempt to tighten the adjustment until the noise disappears. To do so may result in severe damage to the engine. When valves are excessively noisy after adjustment, the components of the valve operating mechanisms should be disassembled and inspected for abnormal wear or faulty components.

On any engine on which valve adjustments have been made, be sure that the adjustment locks are tight and that the valve mechanism covers and gaskets are in place and securely fastened to prevent oil leaks.

Timing Gears (Gear Trains)

Timing gears keep the crankshaft and camshaft turning in proper relation to one another so that the valves open and close at the proper time. In some engines, sprockets and chains are used. The gears or

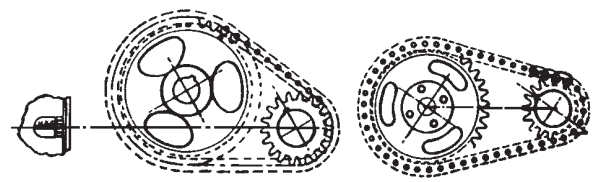

Figure 3-57.—Methods of valve timing with chain drive.

sprockets, as the case may be, of the camshaft and crankshaft are keyed in position so that they cannot slip. Since they are keyed to their respective shafts, they can be replaced if they become worn or noisy.

With directly driven timing gears (fig. 3-56), one gear usually has a mark on two adjacent teeth and the other a mark on only one tooth. To time the valves properly, it is necessary only to mesh the gears so that the two marked teeth of one gear straddle the single marked tooth of the other.

In the case of chain-driven sprockets, the correct timing may be obtained by having a certain number of chain-link teeth between the marks, or by lining up the marks with a straightedge, as shown in figure 3-57. In the latter method, the position of the piston is determined by markings on the engine flywheel. Some engines have timing marks on the crankshaft fan pulley if no opening is provided in the flywheel housing. Always check the manufacturer's instructions when you are in doubt about the method of timing the engine you are overhauling.

Engine Bearings

Bearings are installed in an engine where there is relative motion between parts. Engine bearings are called sleeve bearings because they are in the shape of a sleeve that fits around the rotating journal or shaft. Connecting rod or crankshaft (also called main) bearings are of the split or half type (fig. 3-58). On main

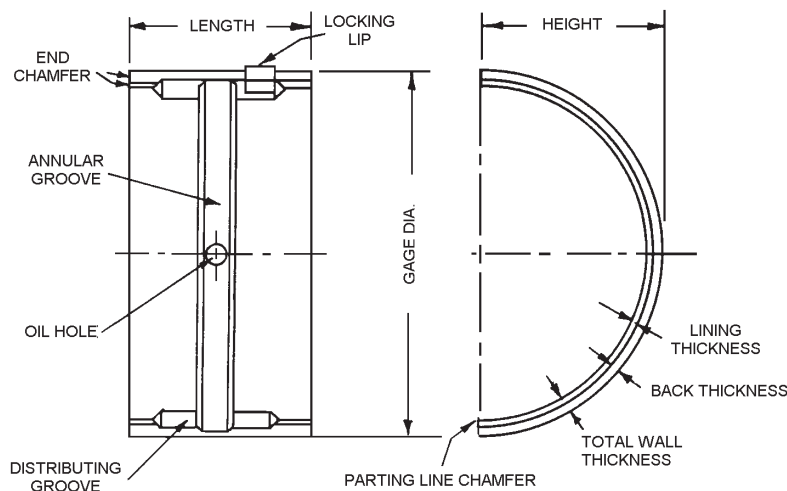

Figure 3-58.—Typical sleeve-type bearing half.

bearings, the upper bearing half is installed in the counter bore in the cylinder block. The lower bearing half is held in place by the bearing cap (refer back to figure 3-16). On connecting-rod bearings, the upper bearing half is installed in the rod and the lower half is placed in the rod cap (refer back to figure 3-25). The small-end (or piston-pin) bearing in the connecting rod is of the full round, or bushing type.

The main bearings in most engines do not have the oil distributing grooves as shown in figure 3-58. They may or may not have the annular grooves; many engines do not. On other engines, only the upper halves of the main bearings have them. On still other engines, both the upper and lower main-bearing halves have the annular grooves. Connecting rod, big-end bearings usually do not have oil grooves.

The typical bearing half is made of a steel or bronze back to which a lining of bearing material is applied. (See fig. 3-58.) The bearing material is relatively soft. Thus, if wear takes place, it will be the bearing rather than the more expensive engine part that wears. Then, the bearing, rather than the engine part, can be replaced when wear has progressed to the replacement point.

BEARING LUBRICATION.—The journal must be smaller in diameter than the bearing so there will be clearance (called oil clearance) between the two parts; oil circulates through this clearance. The lubricating

system constantly feeds oil to the bearing. The oil enters through the oil hole (fig. 3-58) and fills the oil groove in the bearing. From there, the rotating journal carries the oil around to all parts of the bearing. The oil works its way to the outer edges of the bearing. From there, it is thrown off and drops back into the oil pan. The oil thrown off helps lubricate other engine parts, such as the cylinder walls, pistons, and piston rings.

As the oil moves across the faces of the bearings, it not only lubricates them but also helps to cool them. The oil is relatively cool as it leaves the oil pan. It picks up heat in its passage through the bearing. This heat is then carried down to the oil pan and released to the air passing around the oil pan. The oil also flushes and cleans the bearings. It tends to flush out particles of grit and dirt that may have worked into the bearing. The particles are carried back to the oil pan by the circulating oil. They then tend to drop to the bottom of the oil pan or are removed from the oil by the oil screen or filter. The greater the oil clearance (fig. 3-59), the faster the oil will flow through the bearing.

Thus, as bearings wear, more and more oil is thrown onto the cylinder walls. The piston rings cannot handle an excessive amount of oil; part of it works up into the combustion chambers, where it burns and forms carbon. Resulting carbon accumulation in the combustion chambers reduces engine power and causes other engine troubles. Excessive bearing oil clearances

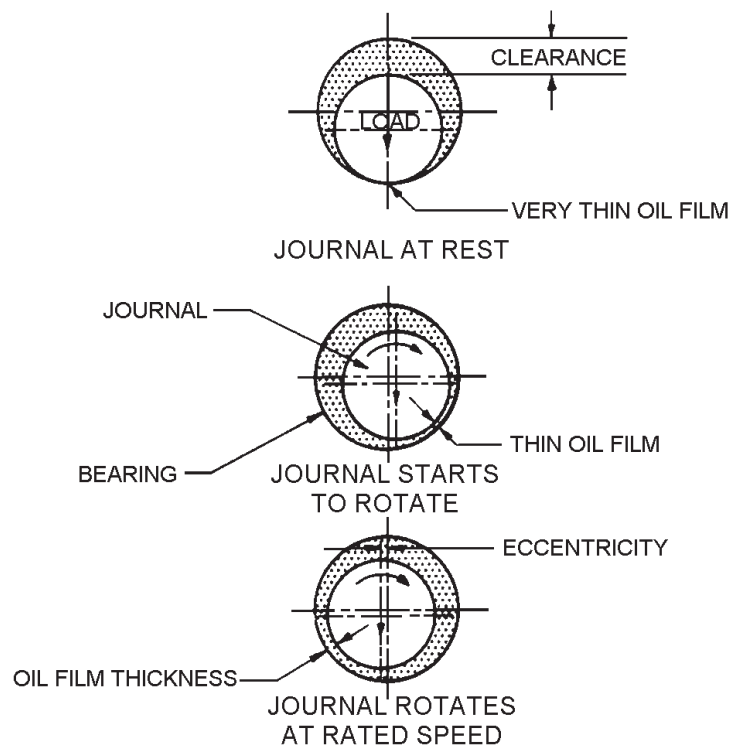

ASf03059

Figure 3-59.—Oil clearance between bearing and shaft.

can also cause some bearings to fail from oil starvation, as the oil pump can deliver only so much oil. If the oil clearances are excessive, most of the oil will pass through the nearest bearings. There won't be enough for the more distant bearings; these bearings will probably fail from lack of oil. An engine with excessive bearing oil clearances usually has low oil pressure; the oil pump cannot build up normal pressure because of the excessive oil clearances in the bearings.

On the other hand, if oil clearances are not sufficiently great, there will be metal-to-metal contact between the bearing and shaft journal. Extremely rapid wear and quick failure will result. Also, there will not be enough oil throw-off for adequate lubrication of cylinder walls, pistons, and rings.

BEARING REQUIREMENTS.—Bearings must be able to do things other than carry the loads imposed on them.

Load-Carrying Capacity.—Modern engines are lighter and more powerful. They have higher compression ratios and thus impose greater bearing loads.

Fatigue Resistance.—When a piece of metal is repeatedly stressed so that it flexes or bends, it tends to harden and ultimately breaks; this is called fatigue failure. Repeatedly bending a piece of wire or sheet metal will demonstrate fatigue failure. Bearings are subjected to varying loads and are repeatedly stressed. The bearing material must be able to withstand these varying loads without failing from fatigue.

Embedability.—This term refers to the ability of a bearing to permit foreign particles to embed in it. Dirt and dust particles enter the engine despite the air cleaner and oil filter. Some of them work onto the bearings and are not flushed away by the oil. A bearing

protects itself by permitting such articles to sink into, or embed in, the bearing lining material. If the bearing were too hard to allow this, the particles would simply lie on the surface. They would scratch the shaft journal and probably gouge out the bearing. This, in turn, would cause overheating and rapid bearing failure. Thus, the bearing material must be soft enough for adequate embedability.

Conformability.—This is associated with embedability. It refers to the ability of the bearing material to conform to variations in shaft alignment and journal shape. For example, suppose a shaft journal is slightly tapered. The bearing under the large diameter will be more heavily loaded. If the bearing material has high conformability, it will flow slightly away from the heavily loaded areas to the lightly loaded areas. This redistributes the bearing material so that the bearing is more uniformly loaded. A similar action takes place when foreign particles embed in the bearing. As they embed, they displace bearing material, thus producing local high spots (fig. 3-60). However, with high conformability, the material flows away from the high spots. This tends to prevent local heavy loading that could cause bearing failure.

Corrosion Resistance.—The bearing materials must be resistant to corrosion, since some of the by-products of combustion may form corrosive substances.

Wear Rate.—The bearing material must be sufficiently hard and tough so that it will not wear too fast. At the same time, it must be soft enough to permit good embedability and conformability.

BEARING MATERIALS.—The bearing back is usually made of steel. The lining material is a combination of several metals, mixed or alloyed, to

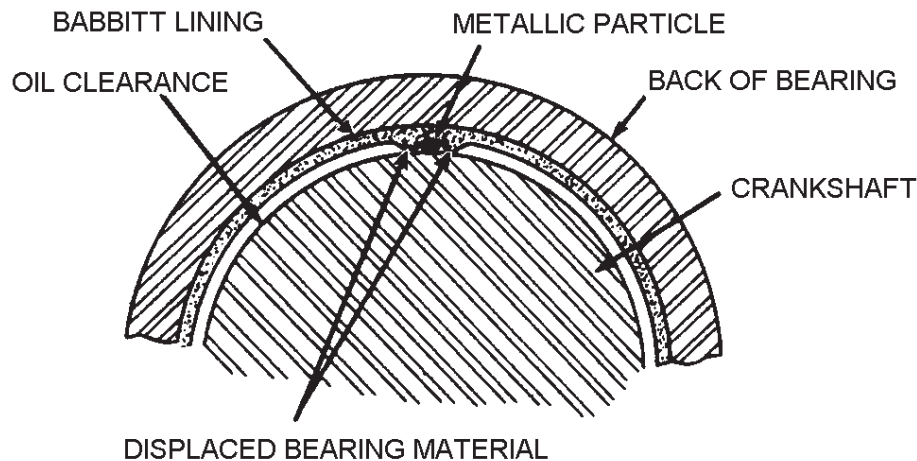

ASf03060
Figure 3-60.—Effect of a metallic particle embedded in bearing material (Babbitt lining).

provide the combination of desired characteristics. Such metals as copper, lead, tin, mercury, antimony, cadmium, and silver are used. Many combinations are possible. Each ingredient, or metal, supplies certain characteristics. The engine designer selects the combination of ingredients that will best suit the engine.

AUXILIARY ASSEMBLIES

In addition to the main parts of the engine, there are other parts, both moving and stationary, that are essential to engine operation. They are not built into the engine itself, but, in most cases, are attached to the engine block or cylinder head.

The fuel system includes a fuel pump and carburetor mounted on the engine. In diesel engines the fuel injection mechanism replaces the carburetor. An electrical system is provided to supply power for starting the engine and also for ignition during operation. An efficient cooling system is necessary for operating an internal combustion engine. In water-cooled engines, a water pump and fan are used, while in air-cooled engines a blower is generally used to force cool air around the engine cylinders.

QUICK ENGINE CHANGE CONCEPT

The engine's parts are designed so that the whole assembly can be removed from and replaced in the vehicle as a unit. This is the non-avionic common aviation support equipment Quick Engine Change Program (QEC). Under the QEC concept, if a unit requires a major engine job, the power plant can be removed and another one quickly installed. Under QEC, the unit is out of service only as long as it takes to swap engines.

For further information on gas and diesel engines and their systems, refer to *Principles of Automotive*

Vehicles, TM 9-8000, and *Detroit Diesel Engines Series 53 Service Manual*, NAVAIR 19-45D-32.

Q3-12. *The spark plug is threaded into which of the following parts of the engine?*

1. *The intake manifold*
2. *The cylinder head*
3. *The engine block*
4. *The valve cover*

Q3-13. *What component connects the piston to the crankshaft?*

1. *The connecting rod*
2. *The drag link*
3. *The piston pin*
4. *The camshaft*

Q3-14. *Which of the following components will prevent the fuel-air mixture in the cylinder from being lost?*

1. *The oil ring*
2. *The intake ring*
3. *The compression ring*
4. *The exhaust ring*

Q3-15. *Which of the following conditions is the first indication of a faulty lifter?*

1. *Excessive oil leaking from the valve cover*
2. *A clicking noise can be heard while the engine is running*
3. *Oil is found in the radiator*
4. *Black smoke is noticed coming from the exhaust*

Q3-16. *Which of the following components keep the camshaft and the crankshaft turning in proper relation to one another?*

1. *The timing marks*
2. *The valve timing indicators*
3. *The horizontal timing unit*
4. *The timing gears*

CHAPTER 4

INTERNAL COMBUSTION ENGINE FUEL SYSTEMS

INTRODUCTION

The fuel system of the internal combustion engine is designed to provide the proper quantity of fuel to the engine under all normal operating conditions. The type of fuel used in either a gasoline or a diesel engine varies according to the design of the engine and the geographical location in which the engine will operate. Additionally, each application of the engine may require changes in the type or design of fuel pump, carburetor, or fuel injection components.

Fuels used in modern Navy equipment are manufactured for use in various geographical locations. For instance, fuels manufactured for use in subzero temperatures must be more volatile than those for use in tropical areas. Otherwise, the fuel in cold climates would not vaporize (evaporate) readily enough to allow efficient engine operation. The result would be hard starting, excessive fuel consumption, and a marked decrease in power developed by the engine. These problems are solved for you by the manufacturer and the supply department. Your concern with the fuel system is in the maintenance and repair of the system's components to ensure long life and economical operation of the engine.

PROPERTIES OF GASOLINE

LEARNING OBJECTIVE: Identify the properties of gasoline. Recognize the differences and uses of various types of fuels.

Gasoline contains carbon and hydrogen in such proportions that the gasoline burns freely and liberates heat energy. If all the potential heat energy contained in a gallon of gasoline could be converted into work, a motor vehicle could run hundreds of miles on each gallon. However, only a small percentage of this heat energy is converted into mechanical energy by the engine. Most authorities consider the power losses within the engine to be as follows:

<u>Engine</u>	<u>Percent of Power Loss</u>
Cooling System	35
Exhaust Gases	35
Engine Friction	5 to 10
Total	75 to 85

The question of what is ideal gasoline is more theoretical than practical. Manufacturers recommend the octane rating of the gasoline they feel is best for the engines they produce. Besides engine design, factors like the weight of the vehicle, the terrain and highways over which it is to be driven, and the climate and altitude of the locality also determine what gasoline is best to use.

The function of the gasoline fuel system is to store, transfer and provide gasoline to the engine in varying quantities to ensure a proper fuel-air mixture at all engine operating speeds. To function properly, the gasoline must have the right qualities to burn evenly regardless of the engine's demands. These qualities include volatility, antiknock quality and detonation, and octane rating.

VOLATILITY

The blend of a gasoline determines its volatility; that is, its tendency to change from a liquid to a vapor at any given temperature. The rate of vaporization increases as the temperature of the gasoline rises.

A gasoline of low volatility brings about better fuel economy and combats vapor lock (the formation of vapor in the fuel lines in a quantity sufficient to block the flow of gasoline through the system). In the summer and in hot climates, fuels with low volatility lessen the tendency toward vapor lock.

ANTIKNOCK QUALITY AND DETONATION

When any substance burns, its molecules and those of the oxygen in the air around it are set into motion, producing heat that unites the two groups of molecules in a rapid chemical reaction. In the combustion chamber of an engine cylinder, the gasoline vapor and oxygen in the air ignite and burn. They combine, and the molecules begin to move about very rapidly, as the high temperatures of combustion are reached. This rapid movement of molecules provides the push on the piston to force it downward on the power stroke.

In modern, high-compression gasoline engines, the fuel-air mixture tends to ignite spontaneously or to explode instead of burning slowly and uniformly. The

result is a knock, a ping, or a detonation. In detonation, the spark from the spark plug starts the fuel mixture burning, and the flame spreads through the layers of the mixture, very quickly compressing and heating them. The last layers become so compressed and heated that they explode violently. The explosive pressure strikes the piston head and the walls of the cylinder, and causes the knock you hear in the engine. It is the fuel, not the engine that knocks. Besides being an annoying sound, persistent knocking results in engine overheating, loss of power, and increased fuel consumption. It causes severe shock to the spark plugs, pistons, connecting rods, and crankshaft. To slow down this burning rate of the fuel, you must use a fuel of a higher octane rating.

OCTANE RATING

The property of a fuel to resist detonation is known as its antiknock or octane rating. The octane rating is obtained by comparing the antiknock qualities of gasoline in a special test engine. In the test engine, the compression can be raised or lowered, and other engine controls are provided to make the engine knock or detonate. Two separate fuel chambers are also provided, with a rapid means of changing from the fuel being tested to the standard reference fuel. This reference fuel consists of a mixture of isooctane, which has a very high antiknock rating, and heptane, which produces a pronounced knock. The octane rating of a gasoline being tested is the percentage by volume of isooctane that must be mixed with normal heptane to match the knocking of the gasoline being tested. Octane numbers range from 50 to over 100. A number higher than 100 indicates that the antiknock value is greater than that of isooctane.

An engine that does not knock on a low-octane fuel will not operate more efficiently by using a fuel of high octane rating. An engine that knocks on a given fuel should use one of a higher rating. If a higher octane fuel does not stop the knocking, some mechanical adjustments are probably necessary. Retarding the spark so that the engine will fire later may end knocking. However, an engine operating on retarded spark will use more fuel and will overheat. It may be less expensive to use a higher priced, high-octane gasoline with an advanced spark than to use a cheaper, low-octane gasoline with a retarded spark.

Also, a spark that is too advanced, a lean fuel mixture, a defective cooling system, or preignition may be responsible for knocking. Preignition should not be confused with engine knock itself, which occurs late in the combustion process after the spark has occurred. In

preignition the fuel-air mixture begins to burn before the spark occurs. This condition may be caused by an overheated exhaust valve head, hot spark plugs, or glowing pieces of carbon within the combustion chamber. Figure 4-1 shows the diagrammed course of the fuel-air mixture in the cylinder under circumstances of preignition and detonation, as well as in normal combustion.

Q4-1. Gasoline's tendency to change from a liquid to a vapor is know by which of the following terms?

1. Octane rating
2. Combustibility
3. Volatility
4. Detonation

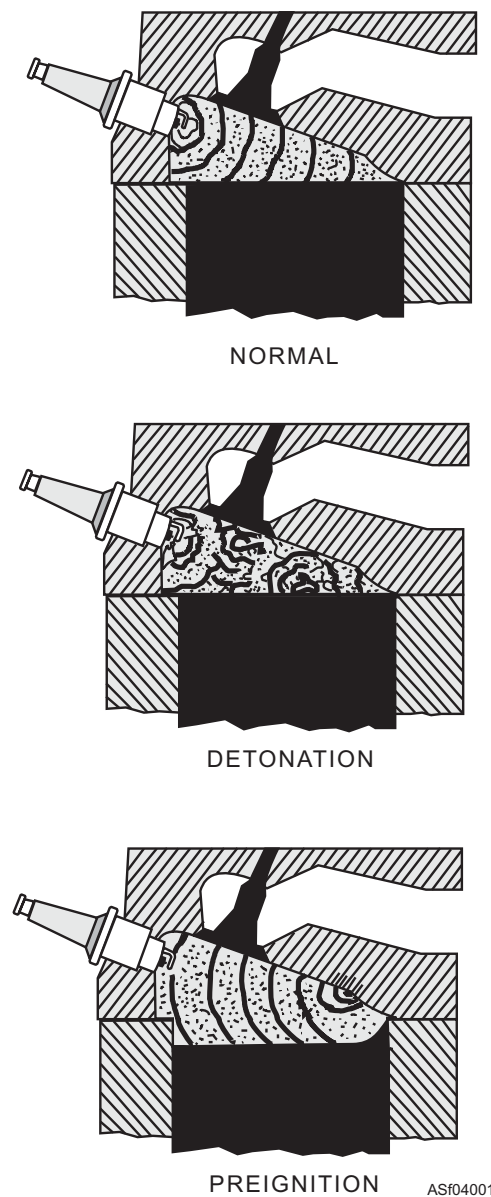

Figure 4-1.—Combustion process.

Q4-2. Which of the following terms best describes the property of a fuel to resist detonation?

1. Compressibility
2. Octane rating
3. Volatility
4. Combustibility

GASOLINE FUEL SYSTEM COMPONENTS

LEARNING OBJECTIVES: Identify the components of a gasoline engine fuel system. Describe engine troubles that can be traced to the carburetor system. Identify two sources from which emissions originate in the gasoline fuel system and engine.

The primary components of a gasoline fuel system (fig. 4-2) are the fuel tank, fuel pump, fuel filter, carburetor, and the fuel lines or tubes that connect the tank, pump, and carburetor. Other components, shown in figure 4-2, are added to support the system.

The fuel system supplies a combustible mixture of gasoline and air to the engine cylinders. It stores the gasoline in liquid form in a fuel tank, and then converts this liquid into a vapor and mixes it with air. The

mixture enters the engine cylinders on the intake strokes; it is then compressed and ignited. In burning, the fuel-air mixture expands and high pressure is produced in the engine cylinders. This pressure forces the pistons downward on the power strokes. The fuel system must vary the proportions of air and gasoline for different operating conditions. For normal running with a warm engine, the proper mixture ratio is about 15 parts air to 1 part gasoline. But for initial starting with a cold engine, a much richer mixture is needed; the mixture does not burn as readily in a cold engine and the gasoline does not turn to vapor so readily. Also, when accelerating, or during high-speed or full-load operation, a richer mixture is required. Richness means a higher proportion of gasoline; a mixture of 9 parts air to 1 part gasoline is a rich mixture. The opposite of richness is leanness. A 16 to 1 mixture ratio is a relatively lean mixture.

Some gasoline engines use a fuel-injection system. With this system, a pump delivers fuel to a fuel injector. The injector then injects the proper amount of fuel into the cylinder head during the intake stroke.

FUEL TANKS

On support equipment, the fuel tank may be mounted in a number of places, depending on the

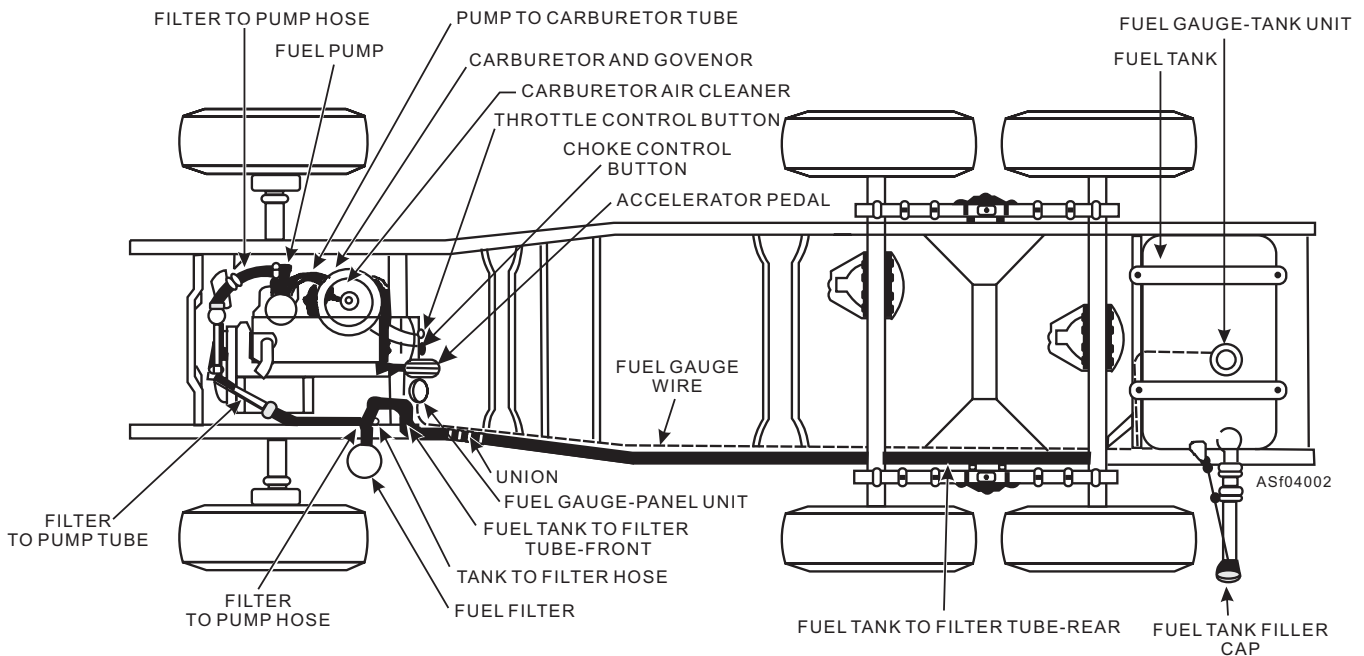

Figure 4-2.—Typical fuel system for a gasoline engine.

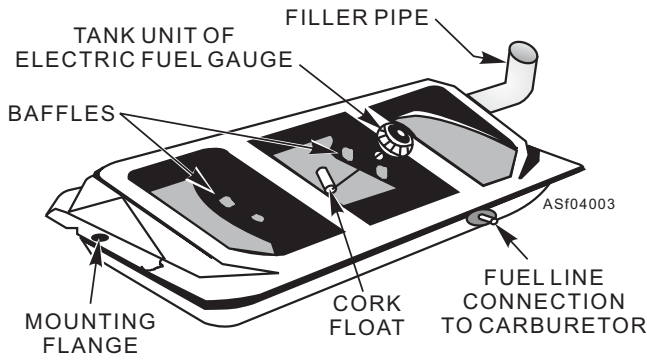

Figure 4-3.—Fuel tank with top cut away.

construction of the equipment. Figure 4-3 shows the general construction of a fuel tank used on automotive equipment. Most fuel tanks are of similar construction. They are usually made of rust-resistant sheet metal, and have an inlet or filler pipe and an outlet. The outlet, with a fitting for the fuel-line connection, may be in the top or side of the tank. The lower end of the outlet pipe is placed about one-half inch from the bottom of the tank so that any sediment that collects in the tank will not be carried to the carburetor. Baffle plates may be placed inside the tank to reinforce the sides and bottom and to prevent the fuel from surging or splashing. A drain plug is placed in the bottom so that the tank can be drained and cleaned. The fuel tank must be equipped with an air vent. This vent is usually located in the cap of the inlet pipe.

Some vehicles, especially aircraft tow tractors, may have more than one tank. On these vehicles, the auxiliary tanks are interconnected, and the flow of fuel from one or more of the tanks may be turned off.

Fuel tanks give little or no trouble, and, as a rule, require no servicing other than an occasional draining and cleaning. However, if they are punctured or develop

leaks, they should not be welded or repaired with or near an open flame until all traces of fuel and fuel vapors have been completely removed from the tank.

WARNING

Before attempting to make any repairs to a fuel tank, always consult with the shop supervisor for specific instructions on all safety precautions to be observed. Remember that fuel tanks can be extremely dangerous.

Fuel Gauges

The fuel gauge is a signaling system that indicates the amount of fuel in the tank. Most fuel gauges are electrically operated and are composed of two units: the gauge itself, which is mounted on the instrument panel of the vehicle; and the sending unit, which is mounted on the fuel tank. An electrical fuel gauge normally operates only when the ignition switch is turned on.

The tank unit of the balancing coil-type fuel gauge (fig. 4-4) has a float and arm assembly connected to a sliding contact. As the fuel level in the tank changes, the position of the contact changes on a rheostat winding, thus varying circuit resistance and resulting current flow. The unit on the instrument panel contains two magnetic coils (limiting coil and operating coil) and a permanent magnet, which is attached to the gauge needle. When the fuel tank is empty, the limiting coil is stronger than the operating coil, thus the magnet is drawn toward it and the needle reads EMPT Y on the gauge. As the tank is filled, the operating coil becomes stronger, attracting the magnet and moving the needle toward the F or FULL position.

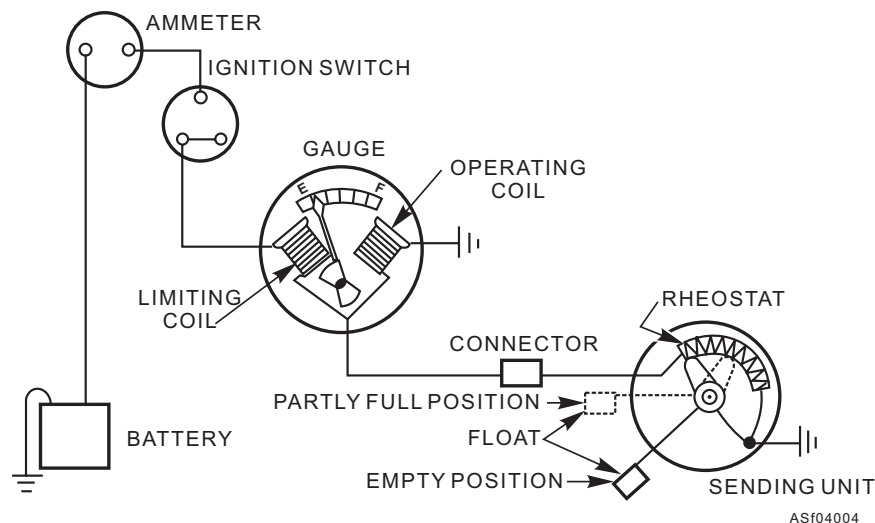

Figure 4-4.—Coil-type gauge circuit.

Fuel Tank Caps

The fuel tank cap is designed to seal the filler tube of the fuel tank and prevent the fuel from escaping on hills and inclines. The cap allows air to enter the tank as the fuel is used, or it seals the opening to the tank when other means of ventilation are used to vent the tank. Using the wrong type of cap can restrict the pumping action of the fuel pump or it may cause the fuel tank to collapse.

FUEL FILTERS

In figure 4-5, a common type of filter is shown attached to the fuel pump. The fuel enters a bowl and passes up through the filter screen, and then out through the outlet. Any water or solid matter caught by the filter falls to the bottom of the filter bowl. Dirt in the fuel generally comes from rust scales in tank cars, storage tanks, and drums. Water caught by the filter generally comes from condensation of moisture in the fuel tank or is introduced through delivery from storage facilities. The filter element is usually a fine metal-mesh screen. Thumbscrews or spring wire clips hold the sediment bulb in place against a cork washer.

Another type of filter is made of a series of laminated discs placed within a large bowl, which acts as a settling chamber for the fuel and encloses the discs or strainer assembly (fig. 4-6). Some vehicles use in line filters with either paper or ceramic elements. These are replaced when the flow of fuel is restricted. Normally the filters are replaced during scheduled maintenance before becoming clogged and causing unscheduled maintenance during operations.

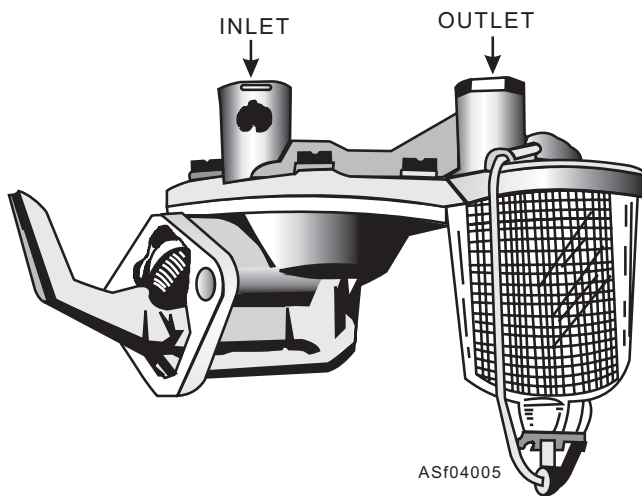

Figure 4-5.—Fuel pump with attached filter bowl.

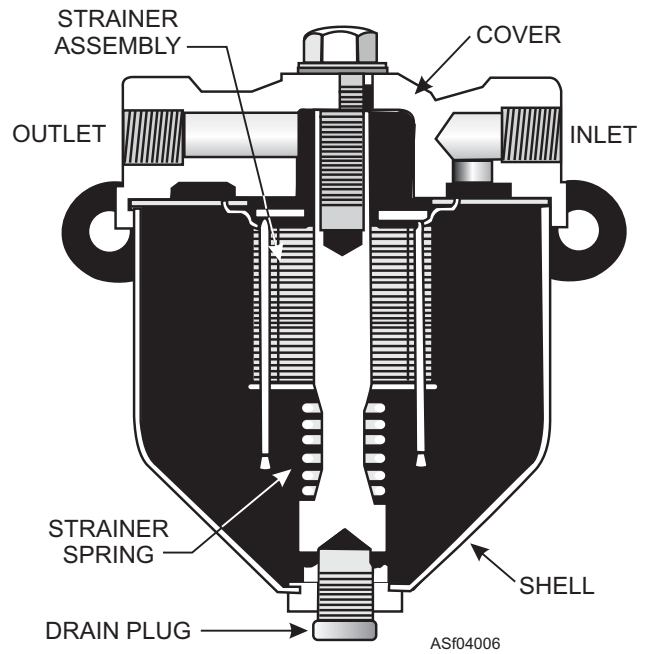

Figure 4-6.—Fuel filter.

FUEL PUMPS

The fuel pump must deliver enough fuel to supply the requirements of the engine, and also maintain a proper pressure in the line between the fuel pump and the carburetor.

Excessive fuel-pump pressure holds the carburetor float needle off its seat, causing a high-gasoline level in the float chamber, which, in turn, increases gasoline consumption. Too low a fuel-pump pressure may cause an insufficient fuel flow into the carburetor and cause air locks (vapor locks) to occur in the fuel lines. Air in the fuel line will interrupt the flow of fuel to the carburetor, resulting in engine power loss or operational failure. The average fuel pump operating pressure will vary from 3 to 5 psi. The pump should be tested periodically to ensure proper operating pressure.

The vacuum gauge is normally used to check the output of the fuel pump. To check the output, remove the fuel line, leading from the pump to the carburetor, from the fuel pump. Attach the vacuum gauge to the fuel line connection with the use of an adapter supplied with the gauge. While cranking the engine, observe the reading on the pressure scale. If no vacuum gauge is available, any liquid pressure gauge designed for use with petroleum products, with a small scale reading, can be used. If pressure is not within the manufacturer's specifications, the pump should be removed and rebuilt or replaced.

During the suction stroke of a mechanical fuel pump, the rotation of an eccentric on the camshaft moves the pump operating arm, which pulls the diaphragm lever and the diaphragm downward. This downward motion against the pressure of the diaphragm spring produces a vacuum in the pump chamber. The vacuum holds the outlet valve closed, while atmospheric pressure pushes the inlet valve open, and fuel is delivered from the supply tank. The fuel flows through the inlet up through the filter screen, and down through the inlet valve into the pump chamber. During the return stroke, the diaphragm is forced up by the diaphragm spring, the inlet valve closes, and the outlet valve is forced open. This action allows the fuel to flow through the outlet to the carburetor.

The diaphragm operating lever is hinged to the pump arm at the arm pivot so that it can be moved down but cannot be raised by the pump arm. The pump arm spring makes that arm follow the cam without moving the lever. The lever is moved upward only by the diaphragm spring. The pump, therefore, delivers fuel to the carburetor only when the fuel pressure in the outlet is less than the pressure maintained by the diaphragm spring. This condition arises when the fuel passage from the pump into the carburetor float chamber is open and the float needle valve is not seated. The carburetor float and needle valve control the fuel level in the carburetor. On some fuel pumps, a dome-shaped air chamber is added to smooth out the pulsation (surging) of fuel being pumped.

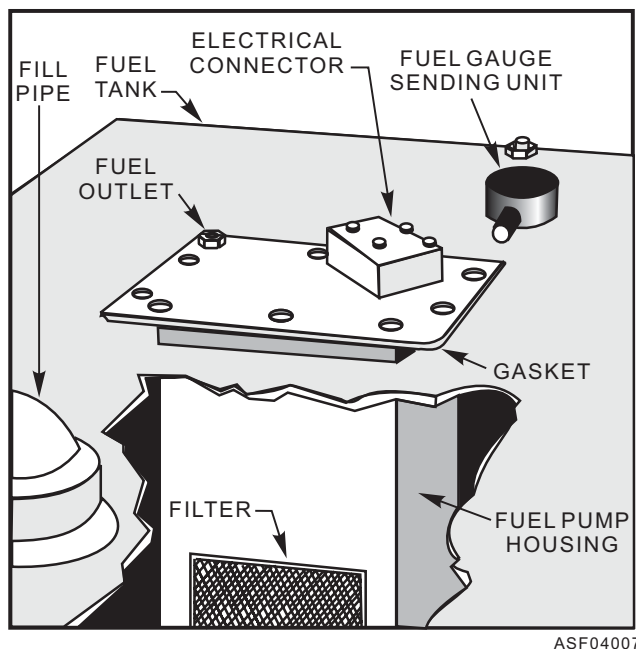

Figure 4-7.—Tank unit type of electric pump.

Fuel pumps are classified as positive and nonpositive diaphragm. The positive type continues to pump fuel even when the carburetor bowl is filled, and thus requires a method of bypassing the fuel back to the tank. The nonpositive diaphragm pump is the one usually found in gasoline engines. It delivers fuel to the carburetor only when it is needed for the requirements of the engine.

One type of electric fuel pump uses a motor to drive a set of gears, impeller, or centrifugal rotor (fig. 4-7), and is installed directly in the tank compartment. The inlet of the pump is submerged in the fuel. This is a positive displacement pump, and return lines are necessary to bring excess fuel back to the tank.

FUEL LINES

Fuel lines connecting the various units of the fuel system have traditionally been made of copper tubing. However, copper tubing is being replaced by steel tubing, which is rustproofed by copper or zinc plating. For more information about cutting and fitting tubing, refer to *Use and Care of Hand Tools and Measuring Tools*, NAVEDTRA 14256. Three kinds of fittings are shown in figure 4-8. These are the flared, compression, and soldered types. Of the three, the flared fitting is most common.

Fuel lines are placed away from exhaust pipes, mufflers, and manifolds so that excessive heat will not cause vapor locks. They are attached to the frame, engine, and other units so that the effects of vibration will be minimized. Fuel lines should be free of contact with sharp edges that might cause wear. In places of excessive movement, as between a vehicle frame

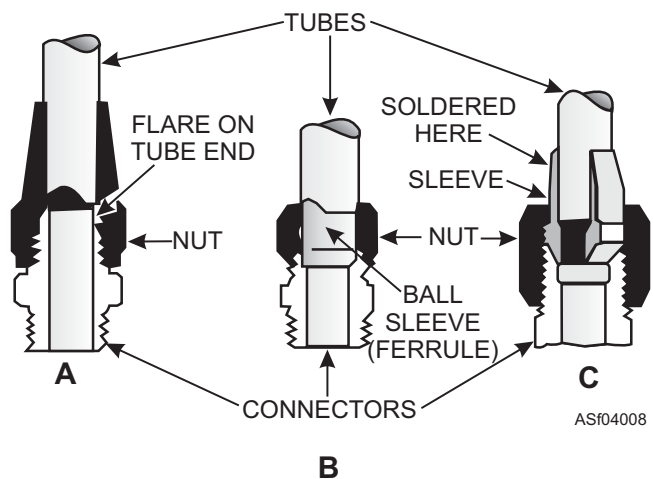

Figure 4-8.—Types of fittings used on fuel lines. (A) Flared. (B) Compression. (C) Soldered.

and rubber-mounted engine, short lengths of gasoline-resistant flexible tubing are used. Occasionally, road vibration may loosen and break the lines, or they may become pinched or flattened by flying rocks. Such damage may interfere with the flow of the fuel.

A certain amount of scale forms within the lines and sometimes causes a stoppage. If this condition occurs, blow the lines clear with compressed air.

CARBURETORS

The principles of carburetion are presented so you may better understand the inner workings of a carburetor and how the other components of the fuel system function to provide a combustible mixture of fuel and air to the engine cylinders.

Air is composed of various gases, mostly nitrogen and oxygen. These gases are, in turn, made up of tiny particles called molecules. All substances, whether solid, liquid, or gas, are made up of molecules. In solids, such as ice or iron, the particles are held very closely together so that they seem to have no motion. In liquids, the molecules are not held together so tightly, so they can move with respect to each other. In gases, there is still less tendency for the molecules to hold together, and the molecules can move quite freely. The molecules of a gas are attracted to the earth by gravity (weight). It is the combined weight of the countless molecules in the air that makes up atmospheric pressure.

When a liquid changes to a vapor, it has evaporated. When this happens, molecules of the liquid move from the liquid into the air. As this continues, the liquid disappears from its container and appears as vapor in the air. The rapidity of evaporation varies with a number of factors. One of these is the volatility of the liquid. Others include temperature, total pressure above the liquid, the amount of liquid, and amount of liquid that has already evaporated into the air above the liquid.

When a substance is heated, the molecules move faster. This is true regardless of whether the molecules are in a solid, liquid, or gas. In other words, the rate of evaporation increases with increased temperature. This action can be seen in the process of boiling water.

When there is little gas (atmospheric) pressure above the liquid, the molecules can escape from the liquid more easily than when the pressure is high. This is to say that liquid in a partial vacuum will evaporate more rapidly than the same liquid under pressure.

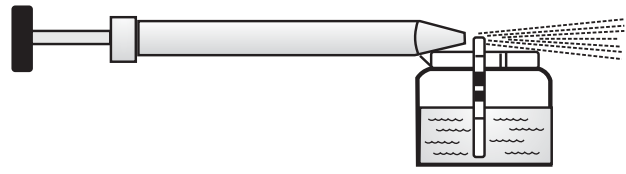

ASf04009

Figure 4-9.—Spray gun.

If the evaporation is taking place in a closed chamber, such as in a jar, evaporation of the liquid will soon stop; the closed space above the liquid will soon become "filled" with escaped molecules. These escaped molecules are in motion, just as all other molecules are moving. Some of the escaped molecules will be knocked back into the liquid. This action balances the escapes so that for every molecule that leaves the liquid, a molecule will re-enter the liquid. As a result, a state of balance exists and evaporation stops.

Volatility refers to the ease with which a liquid vaporizes. A highly volatile liquid evaporates very rapidly. A liquid of low volatility evaporates slowly. Gasoline is a mixture of several different components with varying degrees of volatility.

Atomization means breaking a liquid into very tiny particles or globules. Atomization helps to turn a liquid into a vapor. If a spoonful of gasoline is put into a pan, it will take several seconds for it to evaporate, the length of time depending on temperature, volatility, and pressure. However, if this spoonful of gasoline is put into an ordinary spray gun (fig. 4-9), the gasoline will be broken into a fine mist when the gun is operated. The mist will turn almost instantly into vapor because a much greater area of the liquid is exposed to air when the gasoline is atomized. Evaporation takes place from all surfaces and increases with greater surface area.

A venturi is an hourglass-shaped restriction. In the carburetor (fig. 4-10), a venturi is placed in the air horn

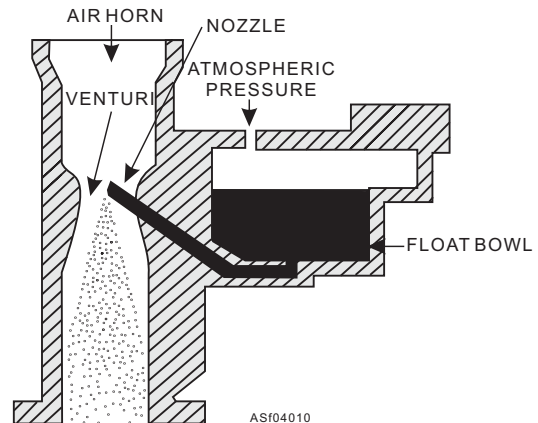

ASf04010

Figure 4-10.—Simplified carburetor.

through which the air must pass on its way to the intake manifold and the engine cylinders. The purpose of the venturi is to create a partial vacuum (pressure less than atmospheric) at the outlet of the fuel nozzle. This will permit the atmospheric pressure on the surface of the gasoline in the float bowl to force the gasoline out through the nozzle. This gasoline then sprays and atomizes in the passing air to form the fuel-air mixture.

Several controls and circuits must be added to the simplified carburetor, shown in figure 4-10, for it to vary the fuel-air ratio for different operating conditions. These controls and circuits include:

- The accelerating system, which momentarily enriches the mixture for improved acceleration when the throttle is opened.
- The maximum power circuit, which enriches the mixture when the throttle is opened wide for high-speed or full-speed operation.
- The float system, for keeping a constant level of gasoline in the carburetor bowl.
- The idling circuit, for supplying an enriched mixture during engine idling.
- The choke circuit for engine starting.

Throttle

The throttle is a device in the carburetor that is used to vary the amount of fuel-air mixture that enters the intake manifold. This is necessary so the speed of the engine can be controlled. The throttle valve (fig. 4-11) is simply a round disc mounted on a shaft so it can be

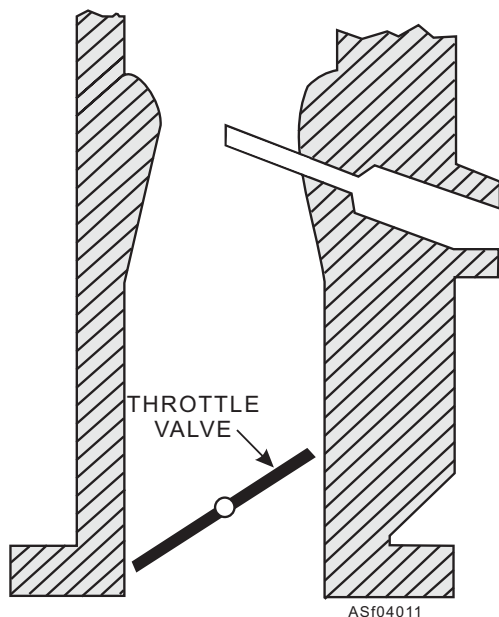

Figure 4-11.—Simplified carburetor with throttle valve.

tilted at various angles in the carburetor throttle valve body. When it is parallel to the airflow, it offers almost no restriction, and a full volume of fuel-air mixture can pass into the intake manifold. The throttle valve is connected by linkage to the control (accelerator pedal or hand throttle) in the driver's compartment/operator control panel.

Float Circuit

The float circuit maintains the fuel level in the carburetor bowl at a constant level during engine operation (fig. 4-12). The float circuit permits fuel to flow into the bowl when the fuel level drops below a predetermined level, and shuts off the flow of fuel when the level reaches the specified height. Up-and-down movement of the float controls the fuel supply by means of a needle valve and seat.

The float level must be set with accuracy in accordance with the manufacturer's specifications. If the fuel level is too low, insufficient fuel will be supplied to the jets, and engine performance will be sacrificed. (A jet is an orifice through which fuel is metered to the fuel nozzle.) On the other hand, if the fuel level is too high, excessive fuel will reach the jets. In fact, fuel may continue to flow from the jets when the engine is stopped. In actual operation, the float and needle valve maintain a position that permits the fuel coming in to just balance the fuel that is flowing to the jets.

Low-Speed Circuit

When the throttle is almost closed, there will be very little air passing through the venturi. Therefore, there will be very little vacuum at the venturi, and the fuel nozzle will not discharge any appreciable amount of fuel. Without some additional circuit to assure fuel delivery with a closed throttle, the engine would stop. The circuit that takes care of fuel delivery during closed or nearly closed throttle is called the idle and low-speed

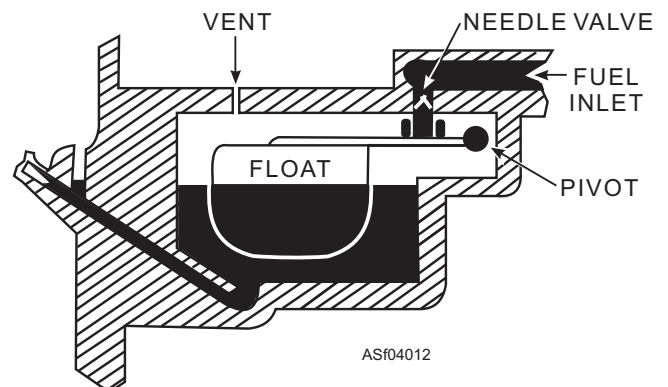

Figure 4-12.—A typical float circuit.

circuit (fig. 4-13). Actually, in some respects, this is really two circuits: an idle circuit and a low-speed circuit.

When the throttle is closed, there is a relatively high vacuum in the intake manifold and below the throttle. The idle circuit has a discharge port, or hole, that is just below the throttle valve when it is closed. With a closed throttle, there is a vacuum in the intake manifold and at the discharge hole. Atmospheric pressure in the float bowl will force fuel from the float bowl through the idle circuit and out the discharge hole. An adjustable needle valve permits more or less fuel to discharge from the hole; this makes it possible to adjust the idling mixture richness by allowing more or less fuel to discharge during idle.

An air bleed allows air to bleed into the idle circuit when it is operating. This air mixes with the fuel and partly atomizes it before it discharges from the hole into the air horn. Some such assistance is needed because air movement through the horn is much slower, and there is less tendency for atomization to take place at the hole during idle. The air bleed also helps to produce fuel flow when pressure differences (between upper and lower portion of the air horn) are low; the mixture flows more easily than liquid fuel alone.

When the throttle is opened a little, the airflow is still too restricted for the venturi to discharge fuel. Yet more air is flowing and, consequently, more fuel must discharge. The idle-circuit discharge hole alone cannot supply this additional fuel. To supply the additional fuel needed for this low-speed operation, an additional hole (low-speed discharge hole or port) is included in the idle circuit. This hole is placed so that it is slightly above the edge of the throttle valve when it is closed, but slightly below the edge of the throttle valve when it is opened a small amount. In this latter position, intake manifold vacuum can act on the low-speed hole, and therefore supply additional fuel from the bowl through the circuit. The same circuit is used by both the idle-

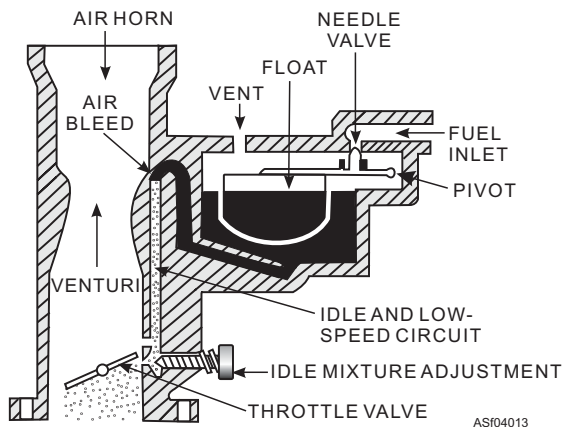

Figure 4-13.—A simple idle and low-speed circuit.

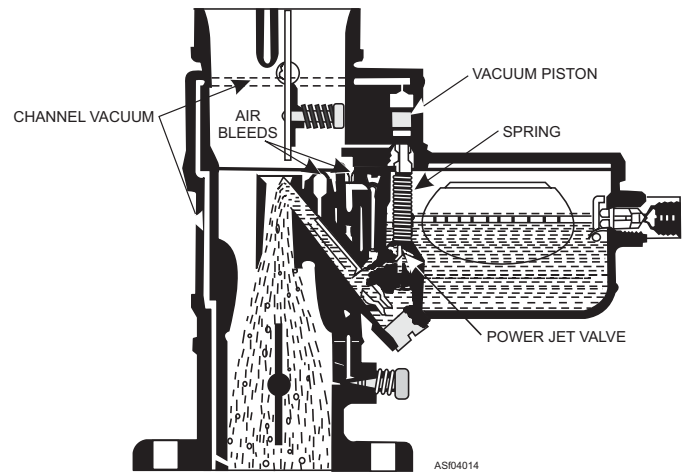

Figure 4-14.—Power jet full load circuit.

and the low-speed holes. The low-speed hole simply permits more fuel to discharge into the throttle-valve body as the throttle is swung away from the fully closed position.

High-Speed Circuit

The high-speed circuit consists essentially of the main nozzle, which is centered in the venturi. The carburetor normally contains a multiple venturi; that is, several venturi, one inside another. When the throttle is opened sufficiently, the air passing through creates a pressure difference that causes a discharge of fuel from the nozzle. Throughout the intermediate- and high-speed range, this discharge increases with the volume of air passing through so that a fairly uniform fuel-air mixture ratio is maintained. Assisting in maintaining this fairly constant ratio is an air bleed that is incorporated in the nozzle. With increased airspeed through the venturi, increased air bleeding into the main nozzle takes place, preventing overrichness. Note the air bleeds in figures 4-14 and 4-15.

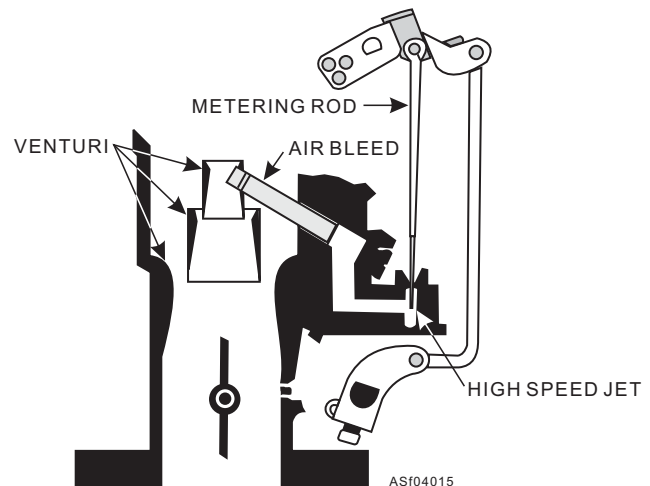

Figure 4-15.—Metering rod full load circuit.

The high-speed and low-speed circuits overlap. As the throttle is moved from closed to opened position, for example, the idle- and low-speed circuit and the high-speed circuit successively take over the main job of supplying fuel. With a closed throttle, the idle discharge hole alone supplies fuel. As the throttle is opened so its edge moves past the low-speed hole, the low-speed hole begins to discharge fuel to meet the added fuel requirements of the engine as engine speed increases. As the throttle opens still wider, the additional and faster moving air through the air horn begins to produce fuel discharge from the main nozzle. As the main nozzle takes over, the low-speed discharge hole no longer functions.

The carburetor is so designed that the fuel-air ratio of the mixture supplied with an open throttle provides economical operation. This ratio is approximately 15:1, by weight.

If the mixture is enriched to approximately 11:1 or 12:1, the engine will produce greater power even though it will not run quite as economically. To increase engine power for high-speed or heavy-load operation (as when pulling an aircraft up a hill), and still maintain reasonable economy, an additional circuit is included in the carburetor that enriches the mixture with a wide-open throttle. This is known as the full-load, high-speed circuit, and it may be of several types.

In some carburetors, a power jet provides the additional fuel necessary for maximum power at wide-open throttle. The power-jet valve (fig. 4-14), controlled by a vacuum-actuated piston assembly, operates in accordance with the throttle opening. With the throttle closed, a high manifold vacuum is present, and the vacuum-controlled piston assembly is moved by atmospheric pressure in the float chamber to the top of its cylinder against the tension of a spring, closing the valve. When the throttle is opened to a point where additional fuel is required, the manifold vacuum has decreased sufficiently so that the spring on the piston assembly moves the piston down, thereby opening the power jet to feed additional fuel into the high-speed circuit. The jet valve is sometimes referred to as the economizer valve, since its operation provides full-power operation where needed and more economical operation at other times.

Instead of using a power jet, some carburetors accomplish the same result by employing a metering rod (fig. 4-15), which varies the size of the high-speed jet openings. Fuel from the float bowl is metered to the high-speed circuit through the calibrated orifice provided by the high-speed jet and the metering rod

within it. From this point, the fuel is conducted to the nozzle, extending into the venturi. As the throttle valve is opened, its linkage raises the metering rod in the jet. The rod has several steps, or tapers, machined on the lower end and, as it is raised in the jet, it makes the effective size of the fuel orifice greater, permitting more fuel to flow through the circuit to meet the load demand imposed upon the engine. At the wide-open throttle position, the smallest step of the metering rod is in the circular opening of the jet, permitting the maximum amount of fuel to flow through the circuit to meet the requirements of maximum power. The metering rod position must be synchronized with every throttle valve position so that the proper ratio of air and gasoline is delivered to the engine for all speeds and driving conditions.

The vacuum step-up (fig. 4-16) operates much like the power jet. It consists of a step-up piston that is fastened to a step-up rod. When high vacuum develops in the intake manifold, as it does under part-throttle operation, atmospheric pressure holds the step-up piston down against its spring pressure so that the step-up rod is held down in the step-up jet, thus closing off the jet. With wide-open throttle, there will be a low vacuum in the intake manifold and the difference in pressure above and below the piston is small. Consequently, the piston is moved up by its spring pressure and the rod is raised out of the jet. Additional fuel for full-power operation is supplied.

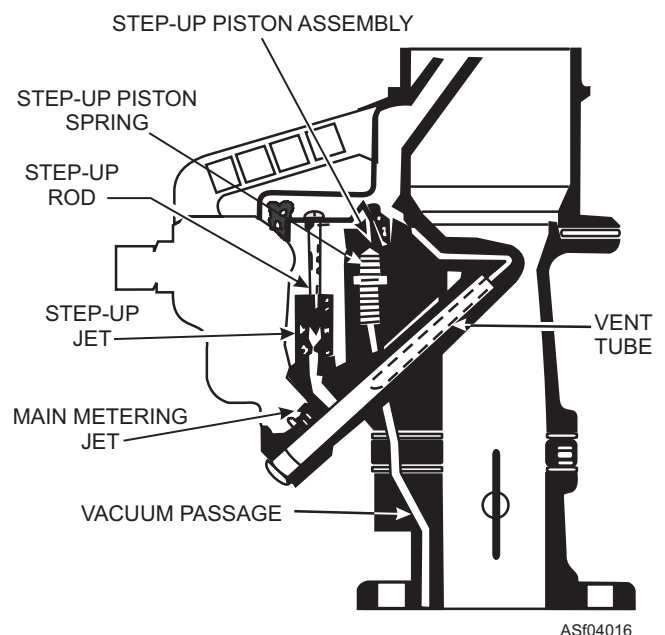

Figure 4-16.—Vacuum set-up high-speed circuit.

Accelerator Pump Circuit

The accelerator pump circuit controls a small amount of fuel that is momentarily discharged into the airstream when the throttle is opened quickly. This extra amount of fuel is necessary to ensure instantaneous response from the engine on acceleration. When the throttle is suddenly opened, air rushes through both the carburetor and the intake manifold. The air is lighter than the liquid fuel and gets into motion quicker, so it reaches the manifold before the fuel charge supplied by the high-speed system. This results in a momentarily lean mixture and hesitation during fast acceleration. To counteract this condition, additional fuel must be supplied; this is accomplished by the accelerator pump circuit.

The accelerator pump circuit consists of the following components:

- A pump cylinder.
- A plunger, mechanically actuated by a lever mounted on the throttle shaft, or vacuum-operated by intake manifold vacuum.
- An intake check valve located in the bottom of the pump cylinder to control the passage of fuel from the bowl into the pump cylinder.
- A discharge check valve.
- An accelerating jet to meter the amount of fuel used.

A typical arrangement with a mechanically actuated plunger is shown in fig. 4-17.

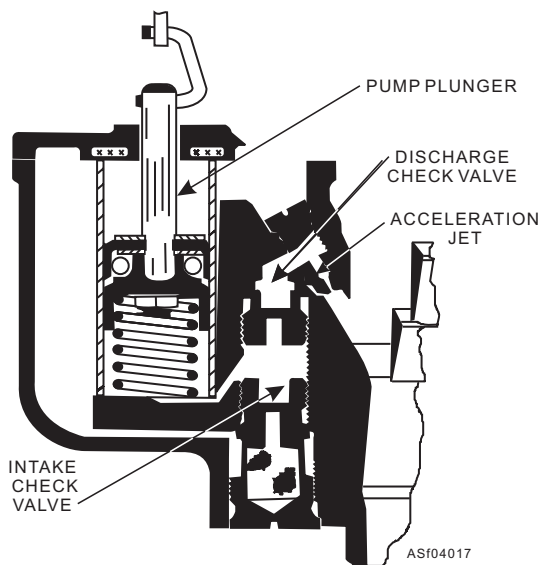

Figure 4-17.—Carburetor accelerator pump circuit.

When the throttle is opened, the pump plunger moves downward in its cylinder. If the plunger is mechanically operated, the downward movement will be brought about by direct linkage with the throttle. If it is vacuum-actuated, a sudden throttle opening will cause the manifold vacuum to drop, allowing the accelerator pump spring to force the pump plunger down in the cylinder. In either case, the subsequent action of the accelerator pump circuit is the same. The downward travel of the plunger forces fuel past the discharge check valve to the accelerating jet, which meters the rate at which it is discharged into the air stream.

Fuel is supplied to the pump cylinder through the intake check valve at the bottom. The level of fuel in the pump cylinder when the plunger is held up to the top of its stroke is approximately equal to the level in the fuel bowl. The intake check valve in the bottom of the cylinder permits a supply of fuel to reach the cylinder, but the valve closes on the downstroke of the plunger, preventing the fuel in the cylinder from being pushed back into the bowl. The accelerator pump discharge is needed only momentarily when the throttle is opened suddenly. To prevent the accelerating jet from flowing at constant throttle openings, some models have an air-vent check valve placed between the accelerating jet and pump cylinder above the fuel level. At steady part-throttle positions, when the pump plunger is inoperative, no pressure exists on the fuel in the pump cylinder. Under this condition, the air-vent check valve will be open and the air will enter the passage connecting the pump cylinder and accelerating jet, preventing fuel from flowing through the jet. The pressure on the fuel, created by the downstroke of the pump plunger, causes the air-vent check valve to close against its seat to prevent the fuel from being discharged back into the bowl through the air-vent passage. On some carburetors, the area above the plunger is connected to the intake manifold so that the accelerator pump does not work while the engine is not running. Under these conditions, the pressure in the intake manifold is near atmospheric and holds the pump plunger down.

Successful operation of the accelerator pump depends on a delayed action, which provides a continual stream of fuel from the pump jet after the throttle has ceased moving. This delayed action takes care of the fuel demands of the engine in the interval that exists between the time the throttle is opened and the time the high-speed nozzle begins to discharge fuel.

Choke Circuit

When the engine is cold, the gasoline vapors tend to condense into large drops on their way to the cylinders. Because all the gasoline supplied to the cylinders will not vaporize, it becomes necessary to supply a richer mixture to have enough vapor to assure combustion. This is accomplished by the choke circuit, which is a choke valve plate placed in the carburetor throat above the venturi.

When an operator sets the choke, the choke valve tilts in the air horn to reduce the amount of air entering the throat, giving a very rich mixture. Only the volatile parts of the gasoline will vaporize at cold temperatures; therefore, a rich mixture is necessary. It provides enough ignitable vapor to start the engine. However, if the choke valve is in the full-choke position, it is completely closed, shutting off the supply of air. Consequently, there is not enough air entering the throat to allow the gasoline to ignite. The necessary air is admitted in manual chokes by either one of two semiautomatic features.

In one design, the choke valve incorporates a spring-loaded poppet valve (fig. 4-18). The poppet is held in the closed position by a weak spring. As soon as the engine turns over, there is sufficient pressure differential to open the valve, allowing a small amount of air to flow.

In the other design, the valve is off-center (fig. 4-19) and operated through a coiled spring on the end of the choke shaft. In the full-choke position, the spring holds the choke valve in the closed position. As soon as the engine turns over, an increased pressure differential

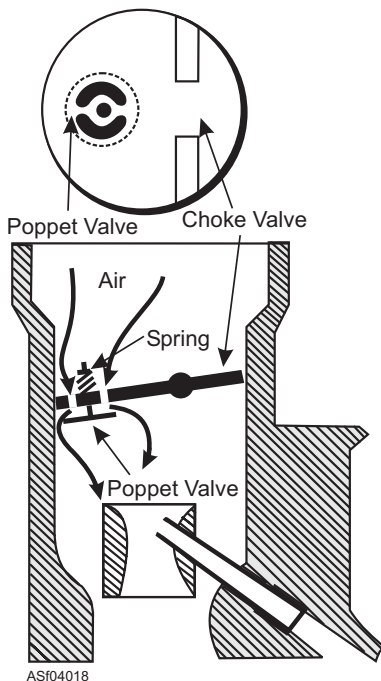

Figure 4-18.—Spring-loaded poppet valve in choke valve.

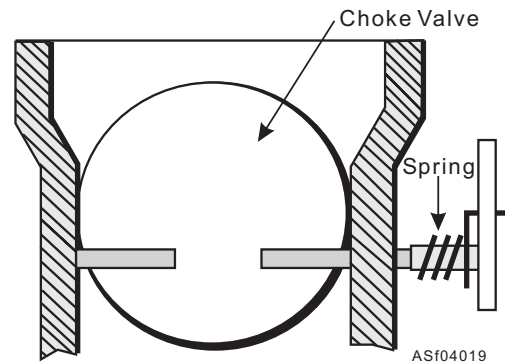

Figure 4-19.—Off-center choke valve.

overcomes the spring tension and opens the choke valve part way, admitting enough air to prevent overchoking or flooding the engine. As the engine warms up, the choke valve is gradually advanced to the wide-open position by the operator to supply the leaner mixture required for a hot engine.

In most modern engines, automatic chokes (figs. 4-20 and 4-21) have replaced the conventional manual choke. They control the fuel-air ratio for quick starting at low temperature and also provide for the proper amount of choking to enrich the fuel-air mixture for all conditions of engine operation during the warm-up period. The automatic choke built into the carburetor in figure 4-20 consists of a thermostatic (bimetal) spring and a vacuum piston, which opposes the action of the spring. The spring is connected to the choke valve in such a manner as to close the valve when the spring is cold. The vacuum piston tends to open the choke valve when the engine manifold vacuum is high. The choke valve is mounted off-center on the choke shaft so that any increase in air velocity through the air horn will tend to open the valve.

The operation of the automatic choke, shown in figure 4-20, is dependent on three factors: heat, intake manifold vacuum, and the velocity of air passing through the air horn. When the engine is cold, the thermostatic spring holds the choke valve closed. When the engine is started, the low pressure (high vacuum) below the throttle valve permits atmospheric pressure to move the piston down and partially open the valve against the tension of the thermostatic spring. Under varying load conditions during warm-up, the position of the choke valve will be changed by the operation of the vacuum piston working against the thermostatic spring, and the air velocity in the air horn. Hot air from the exhaust manifold is directed to the thermostatic spring so that the spring loses its tension as the engine is heated. This permits the choke to open gradually and, after it reaches full-open position, it is held open by the action of the intake manifold on the piston. When the

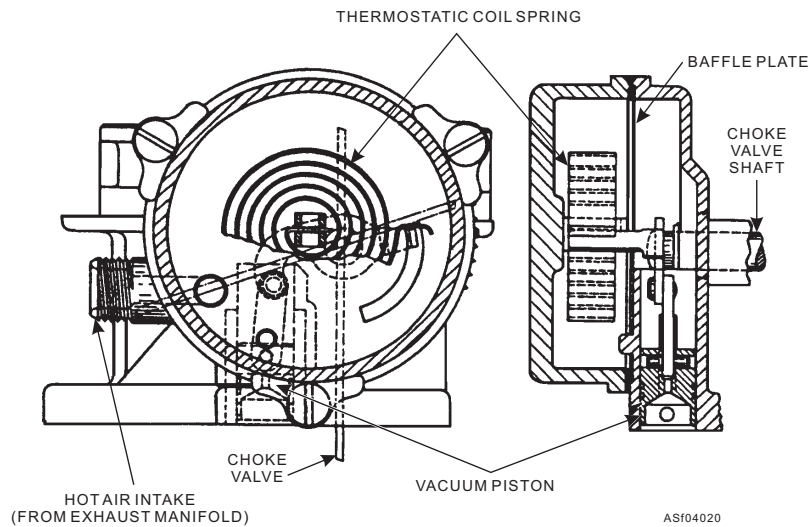

Figure 4-20.—Automatic choke.

engine is stopped, the thermostatic spring cools and closes the choke valve. This choke is adjusted by loosening the screws holding the cover of the thermostatic coil, turning the cover either right or left, and retightening the screws. One trouble encountered with this choke is that carbon from the exhaust causes the vacuum piston to stick; as a result, no choking occurs when the engine is cold.

In figure 4-21, the thermostatic coil is mounted in the manifold and connected to the choke valve by mechanical linkage. A vacuum diaphragm is mounted on the carburetor and attached to the linkage to retard choking action after the engine is started. In the operation of this automatic choke, the thermostatic coil closes the choke valve until the engine is started. After starting, the vacuum diaphragm, in conjunction with the air entering the carburetor throat, overcomes part of the tension acting on the choke valve from the thermostatic coil, and lessens the choking effect. As the engine warms up, the thermostatic coil continues to expand and open the choke until operating temperature of the engine is reached. This type of choke can be adjusted by two methods. Some manufacturers allow for adjustment by providing more than one attaching point of the linkage to the thermostatic coil, while others provide adjustment by bending the mechanical linkage between the thermostatic coil and the choke shaft. Be sure to check the manufacturer's recommendation before adjusting this type of choke.

Carburetor Troubles

Here are some of the engine troubles that usually (but NOT always) can be traced to some fault in the carburetor system:

- **EXCESSIVE FUEL CONSUMPTION.** Can result from a high float level, a leaky float, a sticking metering rod or full power piston, sticking accelerator pump, and too rich an idling mixture.
- **A SLUGGISH ENGINE.** May be the result of a poorly operating accelerator pump, sticking high-speed piston, low float level, dirty or gummy fuel passages, or a clogged air cleaner.
- **POOR IDLING.** Often characterized by stalling of the engine, usually is due to a too-rich idle mixture, a defective choke, or an incorrectly adjusted idle speed screw at the throttle valve.
- **FAILURE OF THE ENGINE TO START.** May be caused by an incorrectly adjusted choke, clogged fuel lines, or air leak into the intake manifold.
- **HARD STARTING OF A WARM ENGINE.** Could be due to a defective or improperly adjusted throttle link.
- **SLOW ENGINE WARM-UP.** May indicate a defective choke or defective radiator thermostat.

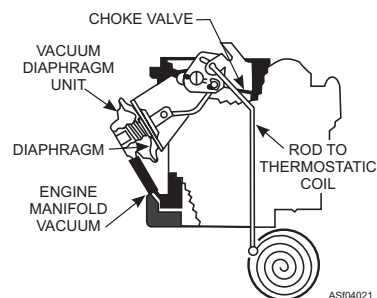

Figure 4-21.—Automatic choke with thermostatic coil mounted in manifold.

- **A SMOKY, BLACK EXHAUST.** Indicates a very rich fuel-air mixture.
- **STALLING OF THE ENGINE AS IT WARMS.** Could be caused by a defective choke or closed choke valve.
- **A BACKFIRING ENGINE.** May be due to an incorrect, often lean, fuel-air mixture reaching the engine. In turn, this condition could be caused by clogged fuel lines or a fluctuating fuel level.

The more stubborn troubles in a carburetor can sometimes be eliminated only with its disassembly and overhauling. The procedures vary according to the manufacturer's specifications, which you should follow closely.

AIR CLEANERS

The air cleaner is placed at the air entrance of the carburetor to remove dust and other foreign matter from the air before it enters the carburetor. A great deal of air, as much as 100,000 cubic feet for every 1,000-vehicle miles, is introduced into the engine. Without an air cleaner, dust and grit would enter the engine with the air and would cause excessive wear and operating troubles. Two types of air cleaner are used: a wet type and a dry type.

The wet-type air cleaner (fig. 4-22) is an oil-bath cleaner, which consists of a main body and a cover. This

unit contains a reservoir of oil and a filter element made of metal gauze or fine metal wool. Air entering the cleaner passes through the opening at the top of the body. The air flows past the oil-filled reservoir picking up particles of oil and carrying them into the filter. The filter traps the oil and particles and allows the oil to seep back to the reservoir. The air finally hits the cover plate and is deflected down through a passage to the carburetor.

The metal gauze or threads in the filter also act as a flame arrester in case of severe flashback or backfire. Many air cleaners are equipped with a silencing unit called the "sound neutralizing chamber." It consists of air-intake passages designed to muffle air noises and a felt pad that acts as a gasket and absorbs engine intake noises.

The dry-type air cleaner (fig. 4-23) uses a treated and pleated paper cleaner element, which requires periodic replacement. The element is sealed in the air breather by pressure against the rubberized material bonded to the filter element and the cover plate and housing. This type of air cleaner element is gradually replacing the oil-bath type because of its ability to remove smaller particles from the airflow into the engine.

A clogged air cleaner produces an action similar to choking that results in too rich a fuel mixture. Foreign matter passed into the engine because of a poor cleaner will also cause excessive engine wear and operating troubles.

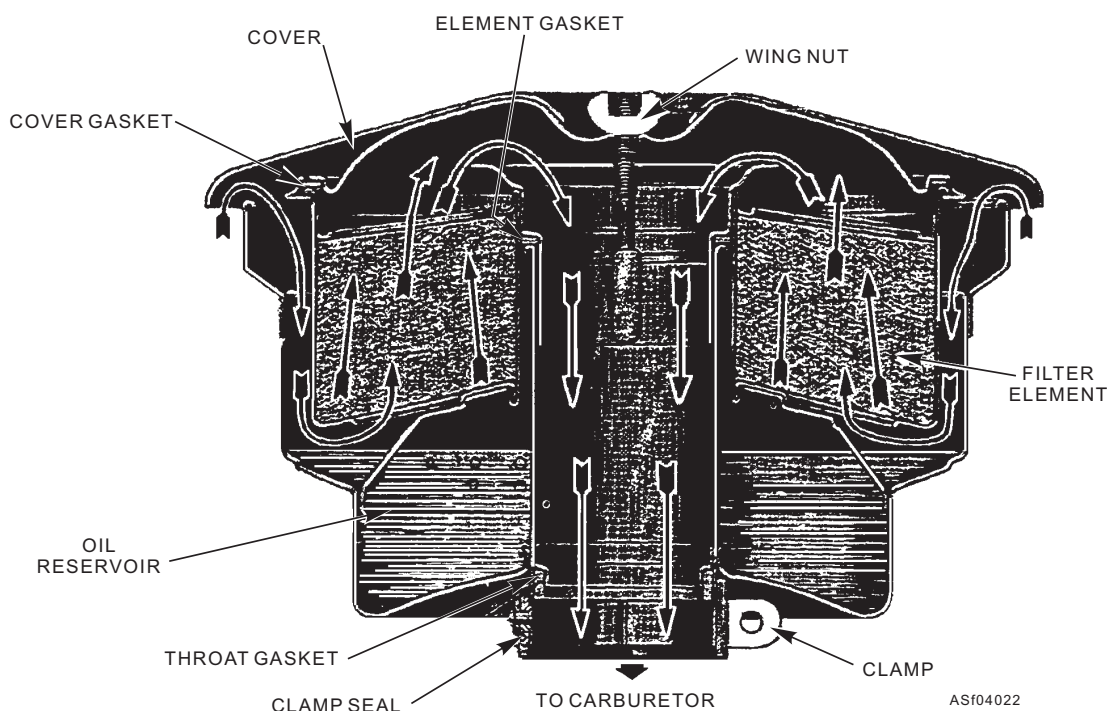

Figure 4-22.—Wet-type air cleaner.

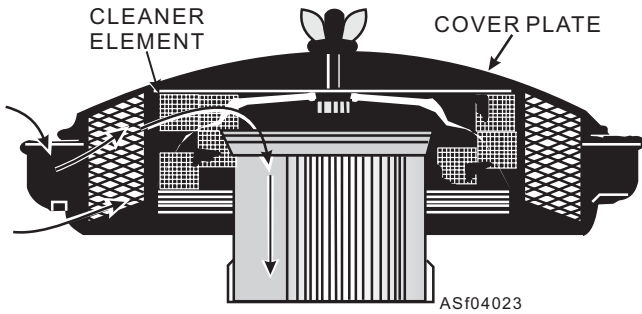

Figure 4-23.—Dry-type air cleaner.

At each scheduled maintenance, remove the air cleaner and wash metallic filter elements in nonflammable cleaning solvent. Paper elements should be replaced at intervals recommended by the manufacturer. Wash the other air cleaner parts. In wet-type cleaners, drain the old oil and add new oil. Be sure that the weight of the new oil conforms to the manufacturer's specifications, and that you add it to the level indicated on the filter body.

WARNING

Never wash metallic filter elements in gasoline, because gasoline can be ignited by static electricity, or even by the friction of rubbing surfaces.

AIR INDUCTION AND EXHAUST SYSTEMS

The intake and exhaust are two of the four basic engine strokes. The intake stroke admits an fuel-air mixture into the cylinder, and the exhaust stroke expels the used gases from the engine cylinder. This text covers the intake and exhaust manifolds, the passageways through which the mixtures are admitted, and the gases expelled.

The intake manifold (fig. 4-24) is usually a cast-iron passage through which the fuel-air mixture passes to each cylinder. The intake manifold should be as short and as straight as possible to reduce chances of condensation and to aid the flow of the mixture from the carburetor. The manifold is mounted on the side of the cylinder block in L-head engines, on the side of the cylinder head in I-head engines, and between the two cylinder banks in V-head engines. The intake manifold is fastened by cap screws or held in place by studs extending from the cylinder block, and is secured by a nut and special washer on each stud. The mounting flange for the carburetor is centrally located on the intake manifold so that a uniform mixture can reach the individual cylinders. Connections between the engine block and the manifold, and between the carburetor and the manifold, must be airtight. These connections are usually sealed by thick gaskets that allow for any slight irregularity in the joining metal surfaces. (Leaks and cracks permit air to enter the engine without passing through the carburetor and air cleaner, resulting in a lean and possibly dirty mixture.)

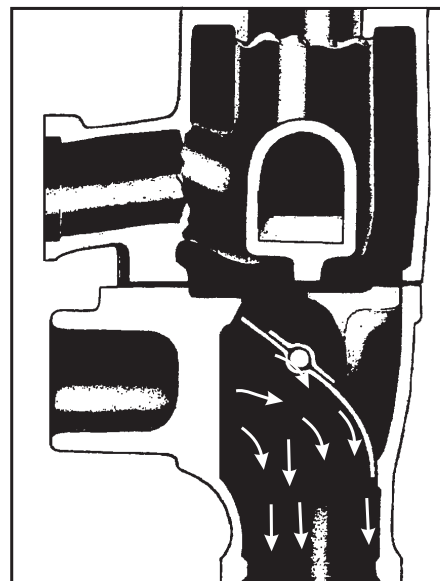
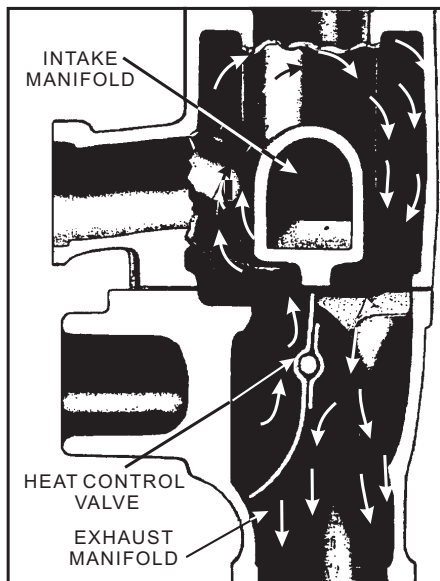

Figure 4-24.—Flow of exhaust gases around intake manifold.

The exhaust manifold is usually a cast-iron passage through which the used gases are carried away from the engine cylinders. It is attached to the side of the cylinder block on L-head engines and to the side of the cylinder head on overhead valve engines. On V-8 engines there are two exhaust manifolds, one for each bank of cylinders. The manifolds are usually connected by a crossover pipe and exhaust through a common muffler and tail pipe. Some vehicles with dual exhausts have two mufflers and two tail pipes, which increase the efficiency of the engine by reducing back pressure.

The gasket between the exhaust manifold and the cylinder block or cylinder head must withstand the intense heat of the exhaust gases. Although gaskets are made of metal-covered asbestos, they can burn, and they will have to be replaced if the connections become loose. Exhaust gas leaks can be detected by smoke discolorations at the connections. If the leak is bad enough, it can be felt and heard when the engine is running.

A device called a manifold heat control valve is often built into the exhaust manifold to promote better vaporization of the fuel during engine warm-up. (See fig. 4-24.) In cold weather, evaporation of the gasoline in the fuel-air mixture entering the engine is poor, since gasoline evaporates more slowly when it is cold. To assist in the vaporization of the fuel, the heat control valve deflects the exhaust gases toward the intake manifold (fig. 4-24) when the engine temperature is low. As the hot exhaust gases pass around the intake manifold, they heat the manifold and the incoming fuel-air mixture.

When the engine is warmed up enough to ensure adequate vaporization of the fuel, the valve turns, as shown in figure 4-24. Now, the used gases are deflected downward into the exhaust pipe and no longer circulate around the intake manifold. The space around the intake manifold that is heated by exhaust gases is sometimes called the "hotspot."

The manifold heat control valve should be checked regularly to make sure it operates freely. If the valve sticks in the warm-up position, the exhaust valves will burn due to the increased temperature that results from the restricted flow of exhaust gases. If you find a stuck valve, add a few drops of penetrating oil mixed with graphite to the shaft, and manually work the valve until it becomes free to operate by spring tension.

Before reaching the tail pipe, the used gases pass down the exhaust pipe through the muffler (fig. 4-25). The muffler, exhaust pipe, and tail pipe comprise the exhaust system.

The muffler quiets the noise of the exhaust by reducing the pressure of the used gases. These gases expand and cool in the separate chambers of the muffler. Flames and sparks leaving the exhaust manifold with the gases are "trapped" by the muffler, which also acts as a flame arrester.

The muffler is connected between the exhaust pipe and the tail pipe by slip joints and clamps and is supported from the frame of the vehicle by straps. Rust on the outside of the muffler is caused by snow, rain, and humidity. Rust on the inside results from burning fuel. You have learned that the products of combustion

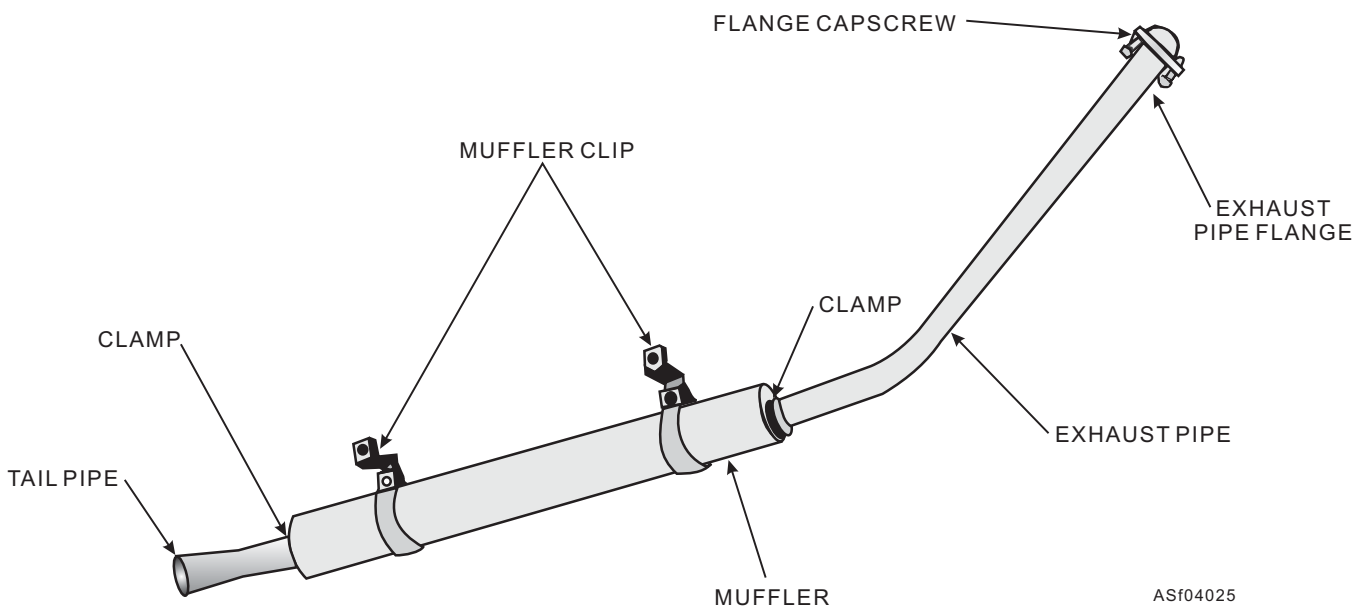

Figure 4-25.—Exhaust pipe, muffler, and tail pipe.

contain water in suspension. This water, trapped in the muffler, will gradually rust it. With every gallon of gasoline that is burned, approximately 6.9 pounds of water are formed, and pass through the muffler. Much of this moisture will remain in the muffler if the vehicle is driven only short distances, but most of it will be expelled if the vehicle is driven speedily for a long distance. In time, the rust, together with the pressure of the exhaust gases, will force holes in the muffler, through which the poisonous fumes of carbon monoxide will seep into the vehicle and can affect the occupants, sometimes fatally.

CAUTION

When you install a muffler, be sure that the small drain hole in the case is at the bottom, and that the clamp fasteners are tight.

Mufflers must be replaced immediately if they are known to be defective. Also, they should be replaced if suspected of being clogged with carbon particles or other foreign matter. Inability of the engine to develop maximum power, difficult starting, and operation of the engine at higher than normal temperatures may indicate clogging of either the muffler or another part of the exhaust system.

The muffler tail pipe or outlet pipe, which extends to the rear of the vehicle (or over the cab on some construction equipment and trucks), should be kept open so that the exhaust gases can escape easily. A pinched or partly closed tail pipe can affect engine operation to the extent that the engine may stop. Unless the used gases are removed from the cylinders, a fresh mixture cannot enter.

Rain caps should be installed on exhaust pipes that extend upward. These caps prevent rain and dirt from entering the exhaust pipe and engine when the equipment is not being used, thus eliminating starting and operating problems. The exhaust pipe of equipment with a turbocharger must be sealed when being transported unless the engine is left running. This prevents damage to the turbocharger, which could be caused by air flowing into the vertical exhaust pipe and turning the turbocharger with no lubrication.

GASOLINE ENGINE EMISSIONS

Air pollution should be a major concern of every American citizen. In many large metropolitan areas where traffic is congested and industry is concentrated, contamination of the air has become a serious problem.

The major causes of air pollution are industry and the gasoline engine. As an AS, you are directly concerned with the prevention of pollution by the gasoline engine and its fuel system. To help reach this goal, you need to know what these polluting substances (emissions) are, where in the gasoline engine and fuel system they originate, how they are controlled, and how controlling devices (emission controls) work to make the vehicles safe for use in our environment.

The emissions from the gasoline fuel system and engine originate from four sources: the fuel tank, carburetor, crankcase, and exhaust. Each source requires its own controlling device.

Fuel systems on older models of gasoline engines were vented to the atmosphere. This method of ventilation allowed fuel vapors containing hydrogen and carbon (HC) to escape. When combined, HC and oxides of nitrogen (NO_x) cause smog in areas where there is a large volume of vehicle traffic. This smog causes reduced vision and irritation to the eyes and respiratory system.

Many changes have been made to gasoline-powered equipment in recent years to reduce the emissions and reverse this trend. All of today's gasoline engines have some type of emission control devices installed. They will in one way or another affect an engine's operation and maintenance procedures. To perform the necessary maintenance on these engines, it is important that you consult the manufacturer's manual for the specific engine and application. This will allow you to make repairs and adjustments without reducing the effectiveness of these devices.

Q4-3. What are the primary components of a gasoline engine fuel system?

- 1. Fuel tank, throttle control button, fuel guage, and accelerator pedal*
- 2. Fuel tank, fuel filter, fuel guage, accelerator pedal, and choke control button*
- 3. Fuel tank, fuel pump, fuel filter, carburetor, and fuel lines*
- 4. Fuel tank, carburetor, fuel guage, fuel lines, and accelerator pedal*

Q4-4. What is the proper fuel-to-air mixture for a warm gasoline engine?

- 1. 15 parts air to 1 part fuel*
- 2. 10 parts air to 1 part fuel*
- 3. 4 parts fuel to 1 part air*
- 4. 1 part fuel to 15 parts air*

- Q4-5. Most fuel level gauges are electrically operated and consist of what two components?*
- 1. A gauge and a sending unit*
 - 2. A level indicator and a float*
 - 3. A gauge and a level indicator*
 - 4. A float and a sending unit*
- Q4-6. Excessive fuel pump pressure in a gasoline engine fuel system will cause which of the following actions?*
- 1. It will cause the fuel float to stick in the closed position*
 - 2. It will hold the fuel float needle valve off its seat*
 - 3. It will increase the engine speed*
 - 4. It will not affect the engine performance because of the pressure regulator*
- Q4-7. What is an average fuel pump operating pressure?*
- 1. 1 to 4 psi*
 - 2. 3 to 5 psi*
 - 3. 5 to 10 psi*
 - 4. 5 to 15 psi*
- Q4-8. Which of the following fuel pumps is normally found in a gasoline engine?*
- 1. A positive displacement pump*
 - 2. An electric pump*
 - 3. A diaphragm pump*
 - 4. A non-positive diaphragm pump*
- Q4-9. What is the purpose of the venturi in a carburetor?*
- 1. It restricts the flow of fuel to create a greater pressure*
 - 2. It creates a backpressure at the fuel nozzle*
 - 3. It creates a vacuum at the outlet of the fuel nozzle*
 - 4. It restricts the flow of air to the intake manifold*
- Q4-10. What circuit in a carburetor permits the flow of fuel into the carburetor bowl?*
- 1. The float circuit*
 - 2. The fuel regulation circuit*
 - 3. The fuel level circuit*
 - 4. The fill circuit*
- Q4-11. Which of the following circuits controls a small amount of fuel that is momentarily discharged into the airstream when the throttle is opened quickly?*
- 1. The high speed circuit*
 - 2. The accelerator pump circuit*
 - 3. The low speed circuit*
 - 4. The acceleration stabilizer circuit*
- Q4-12. What is the reason a choke is set during initial starting of an item of SE?*
- 1. To reduce the amount of fuel required for starting*
 - 2. To increase the air turbulence in the carburetor throat*
 - 3. To reduce the air velocity in the carburetor throat*
 - 4. To reduce the amount of air entering the throat*
- Q4-13. In which of the following locations is the intake manifold located?*
- 1. Between the head and the block*
 - 2. Between the head and the carburetor*
 - 3. Between the carburetor and the block*
 - 4. Between the carburetor and the air filter*

THE DIESEL FUEL SYSTEM

LEARNING OBJECTIVE: Identify the properties of diesel fuel. Identify the most common types of combustion chambers used in support equipment.

Like the gasoline engine, the diesel engine is an internal combustion engine that uses either a 2- or 4-stroke cycle. Power is obtained by the burning or combustion of fuel within the engine cylinders. The diesel engine does not use a carburetor because the diesel fuel is mixed in the engine cylinder with the compressed air.

Compression ratios in the diesel engine range from 14:1 to 19:1. This high ratio causes increased compression pressures of 400 to 600 psi, and cylinder temperatures reach 800° to 1,200°F. At the proper time, the diesel fuel is injected into the cylinder by a fuel injection system, which usually consists of a pump, fuel lines, and injector or nozzle. When the fuel enters the cylinder, it will ignite because of the high temperature. The diesel engine is known as a compression-ignition engine, while the gasoline engine is a spark-ignition engine.

Figure 4-26 shows the comparison of the four strokes of a 4-cycle diesel and a 4-cycle gasoline engine.

The speed of a diesel engine is controlled by the amount of fuel injected into the cylinders; in a gasoline engine the speed of the engine is controlled by the amount of air admitted into the carburetor.

Mechanically, the diesel engine is similar to the gasoline engine. The intake, compression, power, and exhaust strokes occur in the same order. The arrangement of the pistons, connecting rods, crankshaft, and engine valves are about the same. The diesel engine is also classified as inline or V-type.

In comparison to the gasoline engine, the diesel engine produces more power per pound of fuel, is more reliable, has lower fuel consumption per horsepower per hour, and presents less of a fire hazard. These advantages are partially offset by the high initial cost, heavier construction needed for its high-compression pressures, and the difficulty in starting, which results from these pressures.

PROPERTIES OF DIESEL FUEL

Diesel fuel is heavier than gasoline because it is obtained from the residue of the crude oil after the more volatile fuels have been removed. As with gasoline, the efficiency of a diesel fuel varies with the type of engine in which it is used. By distillation, cracking, and blending of several oils, a suitable diesel fuel can be obtained for all engine operating conditions. Slow-speed diesels use a wide variety of heavy fuels; high-speed diesel engines require a lighter fuel. If you use a poor or an improper grade of fuel, it can cause hard starting, incomplete combustion, a smoky exhaust, and engine knocks.

The high injection pressures needed in the diesel fuel system are made possible by close tolerances in the pumps and injectors. These tolerances make it necessary for the diesel fuel to have sufficient lubrication qualities to prevent rapid wear or damage. It must also be clean, mix rapidly with the air, and burn smoothly to produce an even thrust on the piston during combustion.

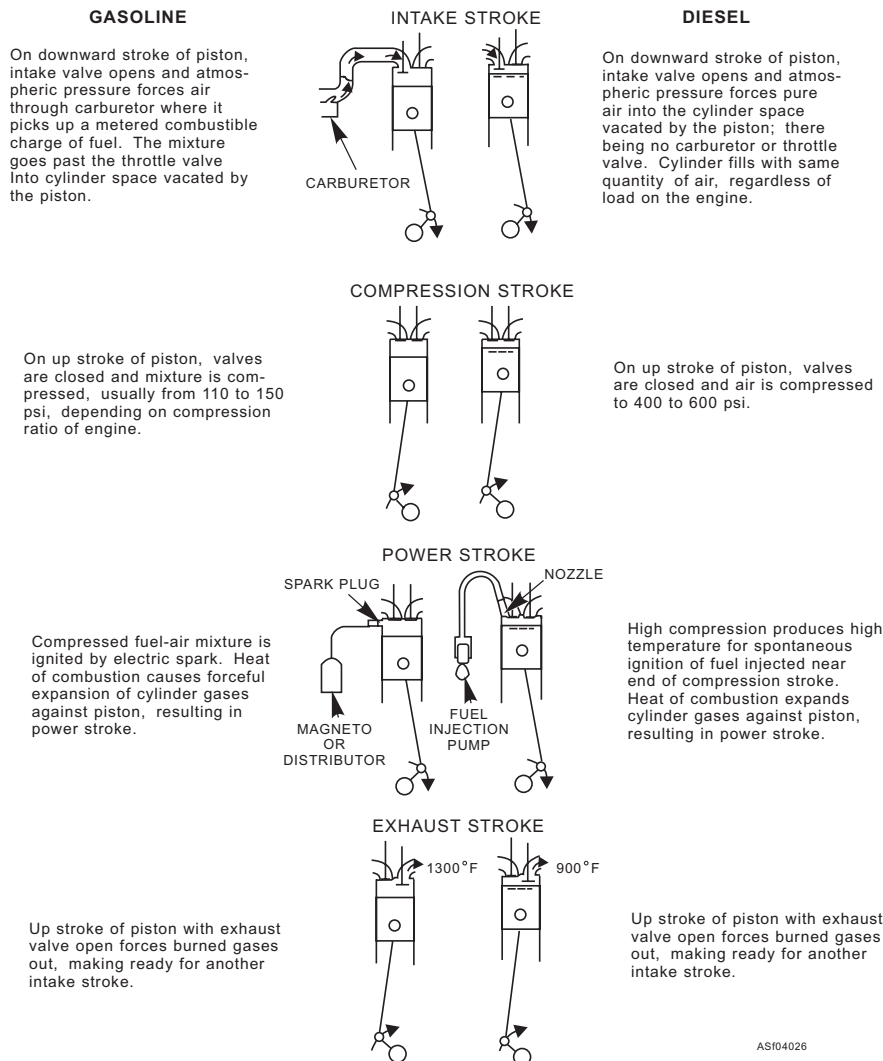

Figure 4-26.—Comparison of sequence of events in diesel and gasoline 4-cycle engines.

The properties to consider in selecting a fuel for a diesel engine are volatility, cleanliness, viscosity, and ignition quality.

Volatility

The volatility of a diesel fuel is measured by the 90-percent distillation temperature. This is the temperature at which 90 percent of a sample of the fuel has been distilled off. The lower this temperature, the higher the volatility of the fuel. In small diesel engines, a fuel of high volatility is more necessary than in large engines if there is to be low fuel consumption, low exhaust temperature, and little exhaust smoke.

Cleanliness

Cleanliness of diesel fuel is very important. Fuel should not contain more than a trace of foreign substances; otherwise, fuel pump and injector difficulties will develop. Because it is heavier and more viscous, diesel fuel will hold dirt particles in suspension for longer periods than will gasoline. In the refining process, not all foreign matter can be removed, and harmful matter like dirt and water can get into the fuel while it is being handled. Water especially will rust an engine. Water will also cause hard starting and misfiring. Dirt will clog injectors and spray nozzles and may cause an engine to misfire or stop altogether.

Viscosity

The viscosity of fuel is the measure of its resistance to flow. Viscosity is expressed by the number of seconds required for a certain volume of fuel to flow through a hole of a certain diameter at a given temperature. The viscosity of diesel fuel must be low enough to flow freely at low temperatures, yet high enough to lubricate the pump and injector plungers properly and lessen the possibility of leakage at the pump plungers and dribbling at the injectors. Viscosity is measured by an instrument called the Saybolt viscosimeter and is expressed in Saybolt seconds, universal (SSU).

Ignition Quality

The ignition quality of a diesel fuel is its ability to ignite when it is injected into the compressed air within the engine cylinders. Ignition quality is measured by the cetane rating of the fuel. A cetane number is obtained by comparing the ignition quality of a given

diesel fuel with that of a reference fuel of known cetane number in a test engine. This reference fuel is a mixture of methylnaphthalene, which is difficult to ignite alone, and cetane, which will ignite readily at temperatures and pressures comparable to those in the cylinders of a diesel engine. The cetane rating indicates the percentage of cetane in a reference fuel that will just match the ignition quality of the fuel being tested. The higher cetane numbers indicate more efficient fuels.

The large, slow diesels can use 30 cetane fuel, but the high-speed diesels must use at least a 40 cetane fuel, while some require as high as a 60 cetane fuel.

Also, the ignition quality of a diesel fuel depends on its flash point and its fire point. The flash point is the temperature to which the fuel vapors must be heated to flash or ignite. The minimum flash point for diesel fuel is 150°F. A fuel with too low a flash point is dangerous both to handle and to store.

The fire point is that temperature at which the fuel vapors will continue to burn after being ignited. It is usually 50 to 120 degrees higher than the flash point.

You will sometimes hear knocks in diesel engines. They are believed to be caused by the rapid burning of the fuel that accumulates during the delay period between injection and ignition. This delay is known as ignition lag or ignition delay. When the fuel is injected into the cylinders, it must vaporize and be heated to the flash point to start combustion. The lag between vaporization and flash point depends upon the ignition quality of the fuel and the speed of the engine and its compression ratio. In high-speed engines, the delay varies from 0.0012 to 0.0018 of a second. Ignition lag decreases with the increase in engine speed because of a swifter air movement in the cylinders that makes the injected fuel heat better. Diesel combustion chambers are designed to provide swift movement of air in the cylinder. The air assists in providing a uniform mixture when the fuel is injected into the cylinder.

COMBUSTION CHAMBERS

Several types of combustion chambers are used in modern diesel engines. They are designed to create turbulence in the cylinder in order to mix the air and fuel effectively. All modern combustion chambers may be classified under one of the following three designs: open type, precombustion type, and turbulence chambers. In support equipment, the most common types are the open combustion chamber and the precombustion chamber.

Open Combustion Chamber

The open combustion chamber (fig. 4-27) is the simplest form of chamber. Due to the design of the piston crown, turbulence is generated as the piston comes up on the compression stroke. The injector is mounted in the cylinder head so that the end extends slightly below the bottom. The fuel is injected directly into the combustion space formed by the top of the piston and the cylinder head. The open chamber requires higher injection pressures and a greater degree of atomization to obtain the proper fuel-air mixture than the other types of combustion chambers. To equalize combustion in the combustion chamber, it uses a multiple orifice-type injector tip for effective penetration and angle of spray.

Precombustion Chamber

Figure 4-28 shows a diagram of a precombustion chamber. This chamber is usually separate from the cylinder head, but is screwed or pressed into the opening provided in the cylinder head. The precombustion chamber is water-cooled because it extends through the water jacket and into the bottom of the cylinder head. It must be sealed at both ends to prevent water leakage. As the piston moves up on the compression stroke, a small part of the compressed air enters the precombustion chamber, where it swirls rapidly within a small space. The fuel nozzle is of the single-hole type and is mounted into the precombustion chamber. As it is injected from a single-hole nozzle, the fuel is only slightly atomized and depends on this highly turbulent air for further atomization and ignition. High pressure builds up inside the

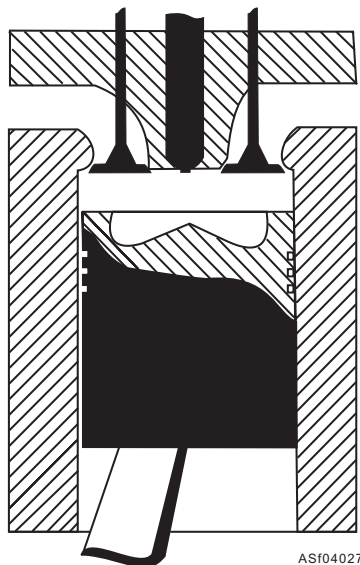

Figure 4-27.—Diesel engine open combustion chamber.

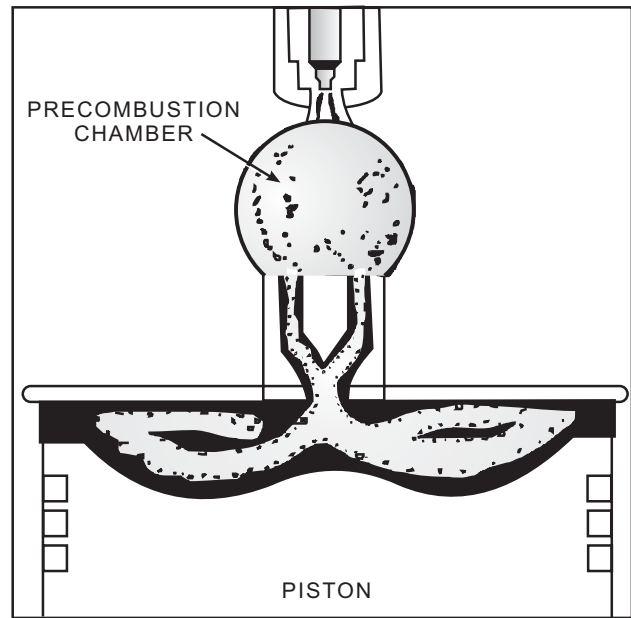

Figure 4-28.—Diesel engine precombustion chamber.

precombustion chamber as ignition begins. This pressure causes the remaining fuel to vaporize and, at the same time, move into the main combustion space.

Turbulence Chamber

The turbulence chamber (fig. 4-29) is similar in appearance to the precombustion chamber, but its function is different. There is very little clearance between the top of the piston and the head, so that a high percentage of the air between the piston and the cylinder head is forced into the turbulence chamber during the compression stroke. The chamber is usually spherical, and the small opening through which the air must pass causes an increase in air velocity as it enters

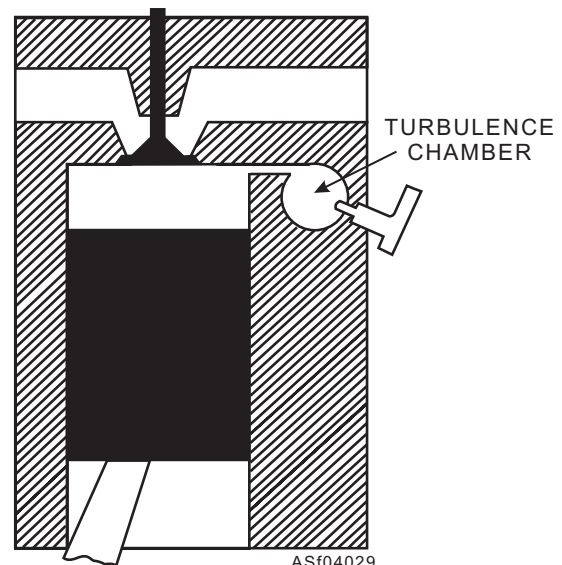

Figure 4-29.—Diesel engine turbulence combustion chamber.

the chamber. The fuel injection is timed to occur when the turbulence in the chamber is greatest. This ensures a thorough mixing of the fuel and air, causing the greater part of combustion to take place in the turbulence chamber. The pressure created by the expansion of the burning gases is the force that drives the piston downward on the power stroke.

Q4-14. Which of the following descriptions best describes a diesel engine?

- 1. It is known as a compression-ignition engine*
- 2. It is known as a spark-ignition engine*
- 3. It is known as a suction-pressure engine*
- 4. It is known as an injection-compression engine*

Q4-15. Which of the following conditions is NOT the result of a poor or an improper fuel grade being used?

- 1. Loss of torque*
- 2. Smoky exhaust*
- 3. Hard starting*
- 4. Engine knocks*

Q4-16. Which of the following factors is very important when dealing with diesel fuel?

- 1. Viscosity*
- 2. Volatility*
- 3. Combustion*
- 4. Cleanliness*

Q4-17. The viscosity of a diesel fuel must be low enough to perform which of the following functions?

- 1. Ignite at low temperatures*
- 2. Prevent knocking of the engine*
- 3. Flow freely at low temperatures*
- 4. Ignite at high temperatures*

Q4-18. Which of the following types of combustion chambers are most commonly used in support equipment?

- 1. Open combustion chamber and pre-combustion chamber*
- 2. Open combustion chamber and turbulence combustion chamber*
- 3. Turbulence combustion chamber and closed combustion chamber*
- 4. Turbulence combustion chamber and pre-combustion chamber*

Q4-19. An open combustion chamber requires which of the following properties to obtain the proper fuel and air mixture?

- 1. Higher air pressure entering the cylinder*
- 2. Higher injection pressure to obtain proper atomization*
- 3. Less air turbulence inside the cylinder*
- 4. Less fuel-to-air ratio to produce combustion*

GOVERNORS

LEARNING OBJECTIVES: Recognize the purpose of governors. Identify the components of selected types of governors.

The speed and the power output of an engine are determined by the combustion process in the cylinders. Since combustion depends upon air and fuel, the speed and the output of an engine can be controlled by regulating the amounts of air and fuel supplied for the combustion process.

In diesel engines, a varying amount of fuel is mixed with a constant amount of compressed air inside the cylinder. A full charge of air enters the cylinder during each intake event. Since the quantity of air admitted is constant, combustion and, in turn, speed and power output are controlled by regulating the amount of fuel injected into the cylinders.

Even though it is not a part of the fuel system, a governor is directly related to this system since it functions to regulate speed by control of the fuel or of the fuel-air mixture, depending upon the type of engine. In diesel engines, governors are connected in the linkage between the throttle and the fuel injectors. The governor acts, through the fuel injection equipment, to regulate the amount of fuel delivered to the cylinders. As a result, the governor holds engine speeds reasonably constant during fluctuations in load. Since the speed and output of a gasoline engine depend on the amount of fuel-air mixture available, governors, when used on these engines, are so connected that they control the amount of the mixture flowing from the carburetor to the intake manifold.

Governors, like carburetors and fuel injection equipment, seem somewhat complicated unless you have a thorough understanding of the construction and operating principles of the equipment. As you progress through the AS rating, you will acquire, through practical experience and study, the knowledge necessary to understand the factors that may seem complicated at the present. For the time being, it is enough to understand the relationship of speed-control devices to the fuel system of an engine.

CONTROL OF ENGINE SPEED AND POWER

In a gasoline engine, speed and output are controlled by regulating the amount of air flowing into the cylinders of the engine. The carburetor is designed to control the airflow. The amount of air and its velocity, in turn, control the quantity of fuel with which the air is mixed before the mixture enters the cylinders.

The throttle valve controls the quantity and velocity of air flowing to the cylinders. By operating the valve, you admit more or less air to the engine, and the carburetor automatically supplies the gasoline necessary to maintain the correct fuel-air ratio. Regulation of fuel or air supply by manual throttle control is adequate when engine speed and output requirements remain constant. However, the requirements of most engines used by the Navy vary because of fluctuating loads. The conditions under which aviation support equipment engines and the engine of a generating unit operate are examples of fluctuating loads. Tow tractors, weapon loaders, and forklifts alternate between heavy loads and no loads. In the case of a generating unit, the demands for electricity are variable. Manual throttle control is not adequate to hold engine speed reasonably constant during such fluctuations in load. For this reason, a speed control device, or governor, is provided to prevent the engine from overspeeding and to allow the engine to meet changing load conditions.

SPEED-REGULATING GOVERNORS FOR DIESEL ENGINES

The type of load and the degree of control desired determine the kind of governor to be used on a diesel engine. Since all governors used on diesel engines control engine speed through the regulation of the quantity of fuel delivered to the cylinders, these governors may be classified under the general heading of speed-regulating governors. Governors used on diesel engines may also be classified in various other ways, such as the function or functions performed, the forces used in operation, and the means by which the governor operates the fuel-control mechanism.

Governors are designed to control engine speed under varying load conditions. Since the type of load and the degree of control desired vary from one type of installation to another, the primary function of a governor depends upon the requirements of a particular installation.

Some installations require that engine speed remain constant from a no-load to a full-load condition. Governors that function to maintain a constant speed, regardless of load, are called "constant-speed" governors. Governors that maintain any desired engine speed between idle and maximum speeds are classified as "variable-speed" governors. Speed-control devices designed to keep an engine from exceeding a specified maximum speed and from dropping below a specified minimum speed are classified as "speed-limiting" governors. (In some cases, speed-limiting governors function only to limit maximum speed.) Some engine installations require a control device that limits the load that the engine will handle at various speeds. Such devices are called "load-limiting" governors.

A governor may also be designed to perform two or more of these functions. In this case, the operating mechanisms that perform the various functions are combined in a single unit.

SPRING-LOADED CENTRIFUGAL GOVERNORS

In most of the governors installed on diesel engines used by the Navy, the centrifugal force of rotating weights (flyballs) and the tension of a helical coil spring (or springs) are used in governor operation. On this basis, most of the governors used on diesel engines are generally called "spring-loaded centrifugal governors."

In spring-loaded centrifugal governors, two forces oppose each other. One of these forces is the tension of a spring (or springs), which may be varied either by an adjusting device or by movement of the manual throttle. The other force is produced by the engine. Weights attached to the governor's drive shaft are rotated, and a centrifugal force is created when the shaft is driven by the engine. The centrifugal force varies directly with the speed of the engine.

The tension of the spring(s) is transmitted to the fuel system through a connecting linkage, and tends to increase the amount of fuel delivered to the cylinders. On the other hand, the centrifugal force of the rotating weights, through connecting linkage, tends to reduce the quantity of fuel injected. When the two opposing forces are equal, or balanced, the speed of the engine remains constant.

To illustrate how the centrifugal governor works, let us assume that an engine operates under load, and that the opposing forces in the governor are balanced, so that the engine speed is constant. If the load is

increased, the engine speed decreases, resulting in a reduction in the centrifugal force of the flyballs. The spring tension then becomes the greater force, and it acts on the fuel-control mechanism to increase the quantity of fuel delivered to the engine. The increase in fuel results in an increase in engine speed until balance of the forces is again reached.

When the load on an engine is reduced or removed, the engine speed increases and the centrifugal force within the governor increases. The centrifugal force then becomes greater than the spring tension and acts on the fuel control linkage to reduce the amount of fuel delivered to the cylinders. This causes the engine speed to decrease until a balance between the opposing forces is again reached and engine speed becomes constant.

OTHER CLASSIFICATIONS OF GOVERNORS

Governors are also classified according to the method by which fuel-control mechanisms are regulated. In some cases, the centrifugal force of the rotating weights regulates the fuel supply directly, through a mechanical linkage that operates the fuel-control mechanism. Other governors are designed so that the centrifugal force of the rotating weights regulates the fuel supply indirectly by moving a hydraulic pilot valve that controls oil pressure. Oil pressure is then exerted on either side of a power piston that operates the fuel-control mechanism.

Governors that regulate the fuel supply directly (through mechanical linkage) are called "mechanical" governors, and those that control the fuel supply indirectly (through oil pressure) are called "hydraulic" governors. Simple governors of the mechanical and hydraulic types are shown in figures 4-30 and 4-31, respectively.

Note that in the illustration of the mechanical governor, the weights, or flyballs, are in an upright position. This indicates that the centrifugal force of the weights and the tension of the spring are balanced; in other words, the engine is operating at constant load and speed. In the case of the hydraulic governor, the positions of the parts indicate that the engine is responding to an increase in load with a resulting decrease in engine speed. Note that the weights tilt inward at the top. As engine speed decreases, the spring tension overcomes the centrifugal force of these rotating weights. When the spring tension is greater than the centrifugal force of the flyballs, the governor mechanism acts to permit oil under pressure to force the piston to increase the fuel valve opening. The increased

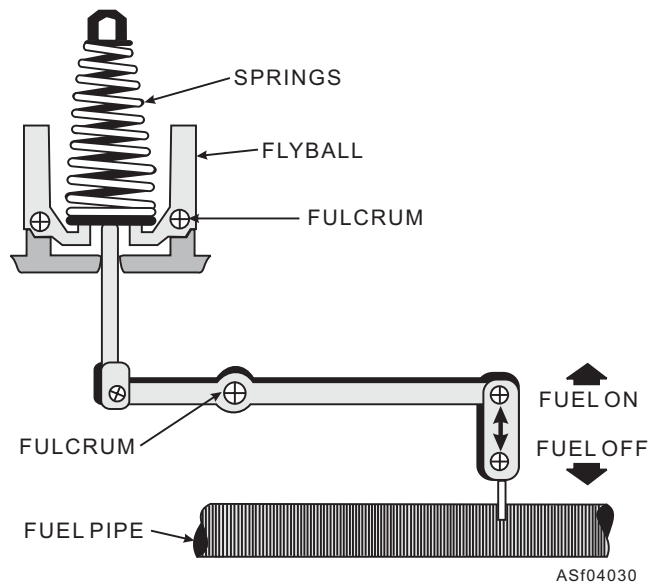

Figure 4-30.—Simple mechanical governor.

fuel supply causes an increase in engine power output and speed. The governor regulates the fuel supply so that enough power is developed to handle the increase in load.

Hydraulic governors are more sensitive than those of the mechanical type. Also, the design of a hydraulic governor enables a comparatively small governing unit to control the fuel mechanism of a large engine. The mechanical governor is used more often on small engines, which do not require extremely close regulation of the fuel. Hydraulic governors are more suitable to large engines, in which more accurate regulation of fuel is necessary.

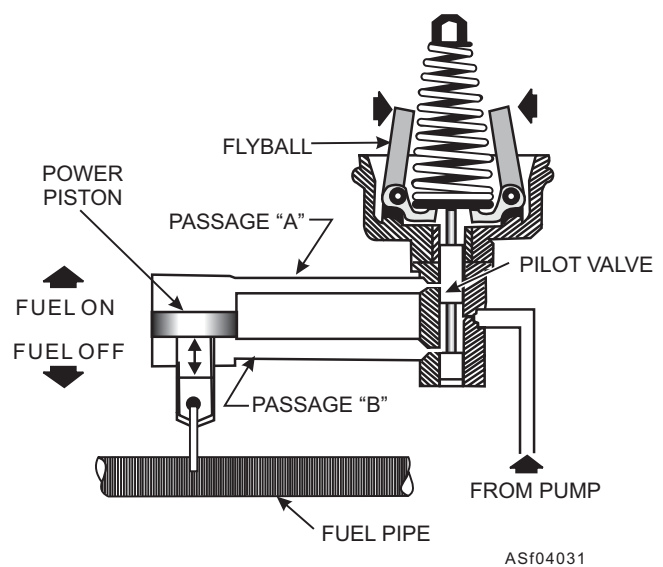

Figure 4-31.—Simple hydraulic governor.

EXCESSIVE SPEED

Engines that are maintained in proper operating condition seldom reach speeds above those for which they are designed. However, there may be times when speeds become too high. The operation of an engine at excessive speeds is extremely dangerous. If the engine speed is high enough, the high inertia and centrifugal force developed may cause parts to become seriously damaged or even to fly apart. Therefore, it is essential that you know why an engine may reach a dangerously high speed, and how it may be brought under control when too much speed occurs.

In some 2-stroke cycle engines, lubricating oil may leak into the cylinders as a result of leaky blower seals or broken piping. Even though the fuel is shut off, the engine may continue to operate or even run away as a result of this combustible material coming from the uncontrolled source. Engines in which lubricating oil may accumulate in the cylinders are generally equipped with an automatically operated mechanism that shuts off the intake air at the inlet passage to the blower. If no air shutoff mechanism is provided and shutting off the fuel will not stop an engine that is overspeeding, anything that can be placed over the engine's air intake to stop airflow, such as a piece of metal or wood, will stop the engine.

WARNING

Do not use your hand! The vacuum is great enough to cause a large blood blister or it may suck the blood out of your hand. Another very great danger is that your hand may be pulled into the blower rotor blades.

Excessive engine speeds more commonly result from an improperly functioning regulating governor than from any other cause. The usual method of accomplishing an emergency shutdown when the regulating governor fails to function properly is to shut off the fuel supply to the cylinders. If this fails to slow the engine or stop it, the air supply to the engine must be cut off.

CAUTION

Do not risk personal injury to stop an overspeeding engine when all normal means have failed.

Shutting off the fuel supply to the cylinders of an engine may be done in various ways. The fuel-control mechanism may be forced to the NO FUEL position; the fuel line may be blocked by closing a valve; the pressure in the fuel injection line may be relieved by opening a valve; or the mechanical movement of the injection pump may be prevented. These methods of shutting off the fuel supply may be done either manually or automatically.

OVERSPEED SAFETY DEVICES

Automatic operation of fuel and air control mechanisms is accomplished by overspeed safety devices. As emergency controls, these safety devices operate only in the event the regular speed governor fails to maintain engine speed within the maximum design limit. Devices that function to bring an overspeeding engine to a full stop by completely shutting off the fuel or air supply are generally called "overspeed trips." Devices that function to reduce the excessive speed of an engine, but allow the engine to operate at safe speeds, are called "overspeed governors."

All overspeed governors and trips depend upon a spring-loaded centrifugal governor element for their operation. In overspeed devices, the spring tension is great enough to overbalance the centrifugal force of the weights until the engine speed rises above the desired maximum. When an excessive speed is reached, the centrifugal force overcomes the spring tension and operates the mechanism, which stops or limits the fuel or air supply.

When a governor serves as the safety device, the actual operation of the fuel or air control mechanism by centrifugal force may be brought about directly, as in a mechanical governor, or indirectly, as in a hydraulic governor. In the case of an overspeed trip, the shutoff control is operated by a power spring. The spring is placed under tension when the trip is manually set, and held in place by a latch. If the maximum speed limit is exceeded, a spring-loaded centrifugal weight moves out and trips the latch, allowing the power spring to operate the shutoff mechanism.

Q4-20. In a diesel fuel system, a governor is connected between what two components?

- 1. The throttle and injectors*
- 2. The throttle and linkage*
- 3. The linkage and injectors*
- 4. The injectors and cylinders*

Q4-21. Which of the following statements best describes the purpose of a governor on a diesel engine?

- 1. To regulate the amount of air entering the cylinder*
- 2. To regulate the amount of fuel going to the carburetor*
- 3. To prevent the engine from overspeeding and allow it to meet changing load conditions*
- 4. To prevent the engine from wet stacking and allow the engine to reach a higher rpm (revolutions per minute) during a fault condition*

Q4-22. What two factors determine the type of governor to be used on a diesel engine?

- 1. The type of fuel and the type of load*
- 2. The type of fuel and the degree of control desired*
- 3. The degree of control desired and the operating environment*
- 4. The type of load and the degree of control desired*

Q4-23. A governor that can maintain any desired speed between idle and maximum speed is classified as what type of governor?

- 1. A speed-limiting governor*
- 2. A spring-loaded centrifugal governor*
- 3. A variable-speed governor*
- 4. A mechanical governor*

Q4-24. A governor that is designed to keep the engine from exceeding a specified maximum speed or dropping below a specified minimum speed is classified as what type of governor?

- 1. A speed-limiting governor*
- 2. A spring-loaded centrifugal governor*
- 3. A variable-speed governor*
- 4. A mechanical governor*

Q4-25. Devices that bring an overspeeding engine to a complete stop by shutting off the fuel or air to the engine are known as what type of devices?

- 1. Overspeed governors*
- 2. Overspeed trips*
- 3. Overspeed limiters*
- 4. Overspeed actuators*

DIESEL FUEL SYSTEM COMPONENTS

LEARNING OBJECTIVES: Identify the components of a diesel engine fuel system. Recognize the purpose of the components of a diesel engine. Identify preheating devices used on diesel engines.

The diesel fuel system is similar to the gasoline system in tank and fuel line construction only. Each manufacturer has their own method of transferring the fuel and creating the high pressure required for injection of the fuel into the cylinders.

FUEL TANKS

The diesel fuel tank is mounted directly on the chassis of SE equipment because of its weight (when filled) and to prevent movement of the tank when the equipment is operated over rough terrain. Its location also depends on the type of equipment and the equipment's use. Fuel tank caps are usually threaded internally and screw onto the tank filler pipe. Most fuel caps are equipped with a sealing gasket and vent hole.

FUEL GAUGES

The electric gauges used on diesel fuel tanks are the same type as used in the gasoline fuel system. Some manufacturers use a bayonet-type gauge that is permanently attached to the filler cap of the fuel tank or installed under the fuel cap. These are graduated and the fuel level is checked by the same method as oil in an engine.

FUEL FILTERS

Fuel filters are built into the fuel supply systems of diesel engines to filter any abrasive impurities that may be in the fuel. These impurities may have been difficult to eliminate during the process of refining, or they may enter the fuel tank through careless refueling. Whatever the source, these impurities must be removed to protect the closely fitted parts in the pumps and nozzles.

Most diesel engines have two filters in the fuel supply system. The primary (coarse) filter is usually located between the supply tank and the fuel supply pump, and the secondary (fine) filter between the fuel supply pump and the injection pump. Additional filtering elements are frequently installed between the injection pump and the nozzle.

Diesel fuel filters are referred to as full-flow filters, since all the fuel must pass through the filters before reaching the injection pumps. Filters must be inspected regularly and cleaned or replaced, if their maximum efficiency is to be maintained. All metal-disc filters are cleanable, but most cloth or fabric elements must be replaced when they become dirty.

Metal Disc Filters

The metal disc filter (fig. 4-32) is made of a series of laminated discs placed within a large bowl, which acts as a settling chamber for the fuel and encloses the discs or strainer assembly. Fuel enters the filter at the top inlet connection and, flowing down, goes between the discs, and then up a central passage to the outlet connection at the top. Dirt and foreign matter cannot pass between the discs and are deposited at the outer rim. The clearance between the discs (0.003 inch) is small enough to prevent the passage of water. This is possible because water, when present in gasoline or oil, forms small globules that are too large to pass between the discs. Note that the filter shown in figure 4-32 also has a cleaning knife. Solids larger than 0.005 inch remain on the outside of the element, and the cleaning knife scrapes these deposits off the filtering discs. The

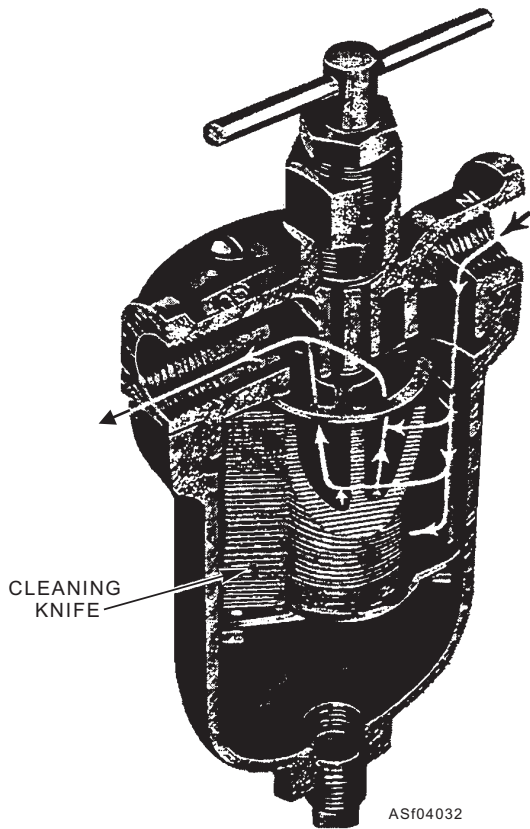

Figure 4-32.—Metal disc fuel filter.

solids fall to the bottom of the filter housing, where they can be removed through the drain plug hole. A ball relief valve in the filter cover enables the fuel to bypass the filter element if the discs become clogged. A diesel fuel filter usually has an air vent for releasing any air that might accumulate in the filter.

Fabric Filters

Fabric filters, because of their greater filtering qualities, are used principally as the main filter for protecting the fuel injection pump. Most fuel systems now use microporous paper fuel filters (fig. 4-33), which are of the replaceable cartridge type.

FUEL SUPPLY PUMPS

Fuel injector pumps must be supplied with fuel under pressure because they have insufficient suction ability. All diesel injection systems require a supply pump to transfer fuel from the supply tank through the filters and lines to the injection pumps. There are two types of supply pumps used on diesel engines today—the gear type and the vane type.

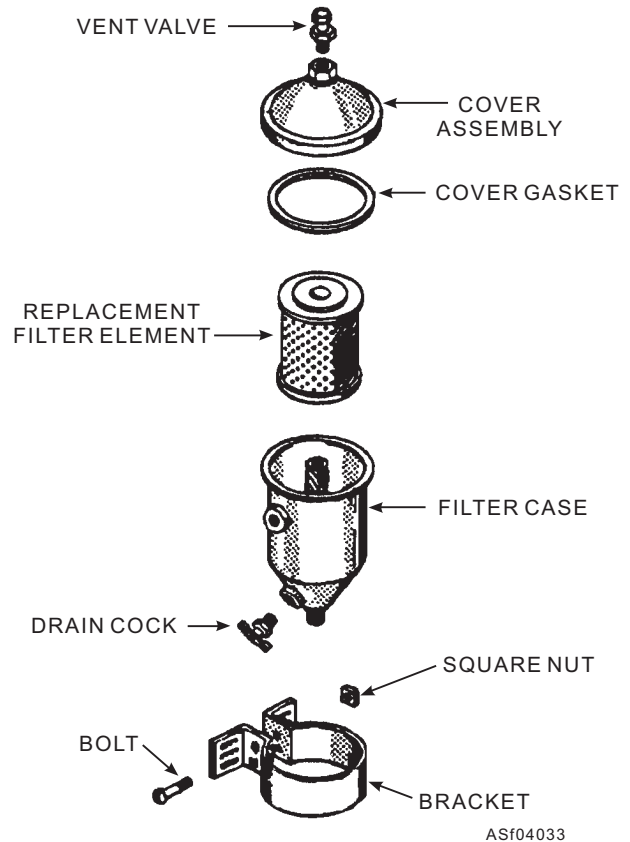

Figure 4-33.—Fuel filter assembly with replaceable element.

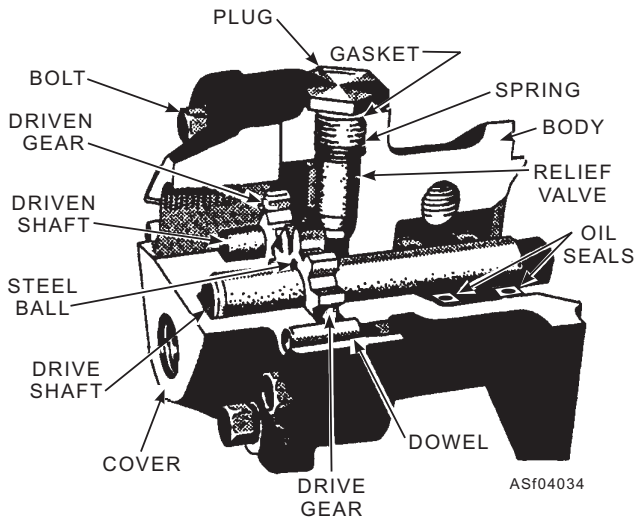

Figure 4-34.—Typical gear fuel pump assembly.

Gear Pumps

The simple gear pump (fig. 4-34) has two spur gears that mesh together; one is the driving gear, the other the driven gear. Clearances between the gear faces and casing are only a few thousandths of an inch. When the gears turn, liquid in the spaces between the

unmeshed teeth, at the suction side of the pump, is carried by the teeth towards the sides. Then, the liquid is trapped between the tooth pockets and the casing, and carried through to the discharge side of the pump. The liquid entering the discharge side cannot return to the suction side because the meshing teeth at the center force the liquid out of the tooth pockets.

Vane Pumps

In the vane-type pump (figs. 4-35 and 4-36), a steel rotor and shaft, one end supported in the pump cover, revolve in the body, the bore of which is eccentric to the rotor. Two sliding vanes are placed 180 degrees apart in slots in the rotor, and are pressed against the body bore by springs in the slots. When the shaft is rotated, the vanes pick up fuel at the inlet port and carry it around the body to the outlet side, where the fuel is discharged. Pressure is produced by the wedging action of the fuel as it is forced toward the outlet port by the vane. A spring-loaded relief valve is provided in the cover of the pump, connecting the inlet and outlet ports. This valve opens at a pressure of approximately 55 psi. Its purpose is to relieve excessive pump pressure, which will build up if fuel lines or filters become clogged. When the valve opens, fuel passes from the discharge side (pressure side) to the suction side of the pump.

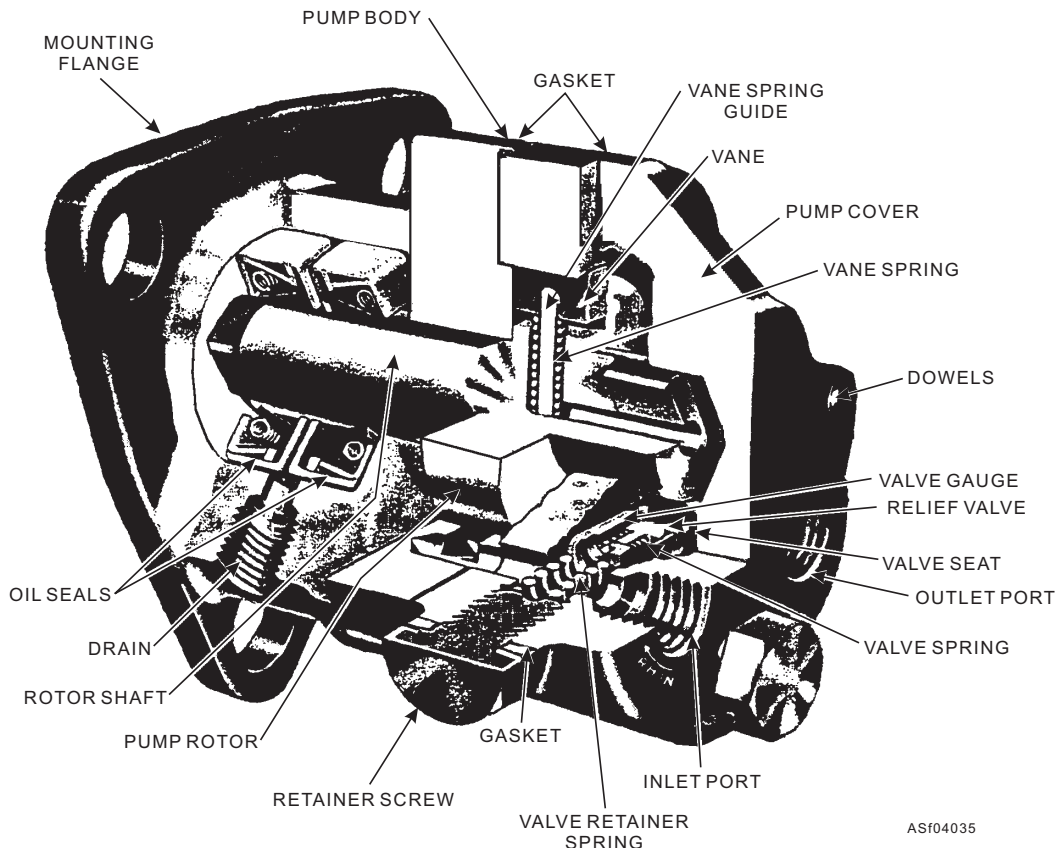

Figure 4-35.—Cutaway view of vane-type fuel pump.

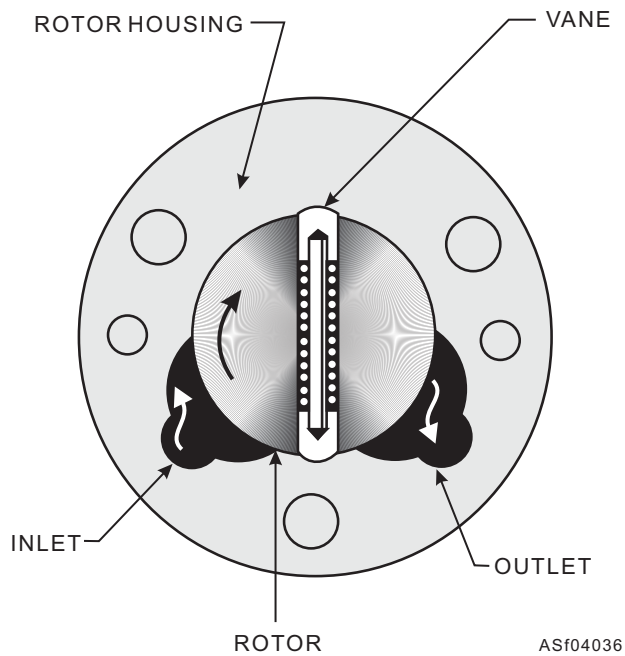

Figure 4-36.—Vaness and rotor in housing of a vane-type fuel pump.

The remaining task to be accomplished by the fuel system is to provide the proper quantity of fuel to the engine's cylinders. This is done differently by each manufacturer and is referred to as fuel injection.

FUEL INJECTION

Diesel fuel injection systems must accomplish five particular functions: meter, inject, time, atomize, and create pressure. A description of these functions follows:

- **METER.** Accurately measures the amount of fuel to be injected.
- **INJECT.** Forces and distributes the fuel into the combustion chamber.
- **TIME.** Injection of the fuel must start and stop at the proper time.
- **ATOMIZE.** Breaks the fuel up into fine particles.
- **CREATE PRESSURE.** Creates the necessary high pressure for injection.

You can remember these functions by the initials MITAC. All five of these functions are necessary for complete and efficient combustion.

Metering

Accurate metering or measuring of the fuel means that, for the same fuel control setting, the same quantity

of fuel must be delivered to each cylinder for each power stroke of the engine. Only in this way can the engine operate at uniform speed with a uniform power output. Smooth engine operation and an even distribution of the load between the cylinders depend upon the same volume of the fuel being admitted to a particular cylinder each time it fires, and upon equal volumes of fuel being delivered to all cylinders of the engine.

Injection Control

A fuel system must also control the rate of injection. The rate at which fuel is injected determines the rate of combustion. The rate of injection at the start should be low enough that excessive fuel does not accumulate in the cylinder during the initial ignition delay (before combustion begins). Injection should proceed at such a rate that the rise in combustion pressure is not too great, yet the rate of injection must be such that fuel is introduced as rapidly as possible to obtain complete combustion. An incorrect rate of injection affects engine operation in the same way as improper timing. When the rate of injection is too high, the results are similar to those caused by a too early injection; when the rate is too low, the results are similar to those caused by a too late injection.

Timing

In addition to measuring the amount of fuel injected, the system must properly time injection to ensure efficient combustion so that maximum energy can be obtained from the fuel. When the fuel is injected too early in the cycle, ignition may be delayed because the temperature of the air at this point is not high enough. An excessive delay, on the other hand, gives rough and noisy operation of the engine, and also permits some fuel to be lost due to the wetting of the cylinder walls and piston head. This, in turn, results in poor fuel economy, high exhaust gas temperature, and smoke in the exhaust. When fuel is injected too late in the cycle, all the fuel will not be burned until the piston has traveled well past top center. When this happens, the engine does not develop its maximum power, the exhaust is smoky, and the fuel consumption is high.

Atomization of Fuel

As used in connection with fuel injection, atomization means the breaking up of the fuel, as it enters the cylinder, into small particles that form a mist-like spray. Atomization of the fuel must meet the

requirements of the type of combustion chamber in use. Some chambers require very fine atomization; others function with coarser atomization. Proper atomization makes it easier to start the burning process, and ensures that each minute particle of fuel is surrounded by particles of oxygen with which it can combine.

Atomization is generally obtained when the liquid fuel, under high pressure, passes through the small opening (or openings) in the injector or nozzle. As the fuel enters the combustion space, high velocity is developed because the pressure in the cylinder is lower than the fuel pressure. The created friction, resulting from the fuel passing through the air at high velocity, causes the fuel to break up into small particles.

Creating Pressure

A fuel injection system must increase the pressure of the fuel enough to overcome compression pressures and to ensure proper dispersion of the fuel injected into the combustion space. Proper dispersion is essential if the fuel is to mix thoroughly with the air and burn efficiently. While pressure is a chief contributing factor, the dispersion of the fuel is influenced, in part, by atomization and penetration of the fuel. (Penetration is the distance through which the fuel particles are carried by the motion given them as they leave the injector or nozzle.)

If the atomization process reduces the size of the fuel particles too much, they will lack penetration. Too little penetration results in the small particles of fuel igniting before they have been properly distributed or

dispersed in the combustion space. Since penetration and atomization tend to oppose each other, a compromise in the degree of each is necessary in the design of fuel injection equipment, particularly if uniform distribution of fuel within the combustion chamber is to be obtained.

Methods of Fuel Injection

There are several types of fuel injection systems used in today's SE diesel engines. Some engine manufacturers make and install their own fuel injection equipment. Others rely on manufacturers who specialize in fuel injection equipment and who design or modify their product to meet the requirements of the engine manufacturer.

ROOSA MASTER FUEL INJECTION PUMP

—The Roosa Master fuel injection pump commonly used is the opposed plunger, inlet metering, twin cylinder (Model DC), distributor type pump. The main components are the drive shaft, distributor rotor, transfer pump, pumping plungers, internal cam ring, hydraulic head, end plate, governor, and the pump housing with an integral advance mechanism. Early advance mechanisms are attached to the pump housing and can be removed from the housing as a unit for servicing.

The rotating members that revolve on a common axis include the drive shaft, distributor rotor, and transfer pump.

In the Model DC pump (fig. 4-37), the driving member is the drive shaft that rotates inside a pilot tube

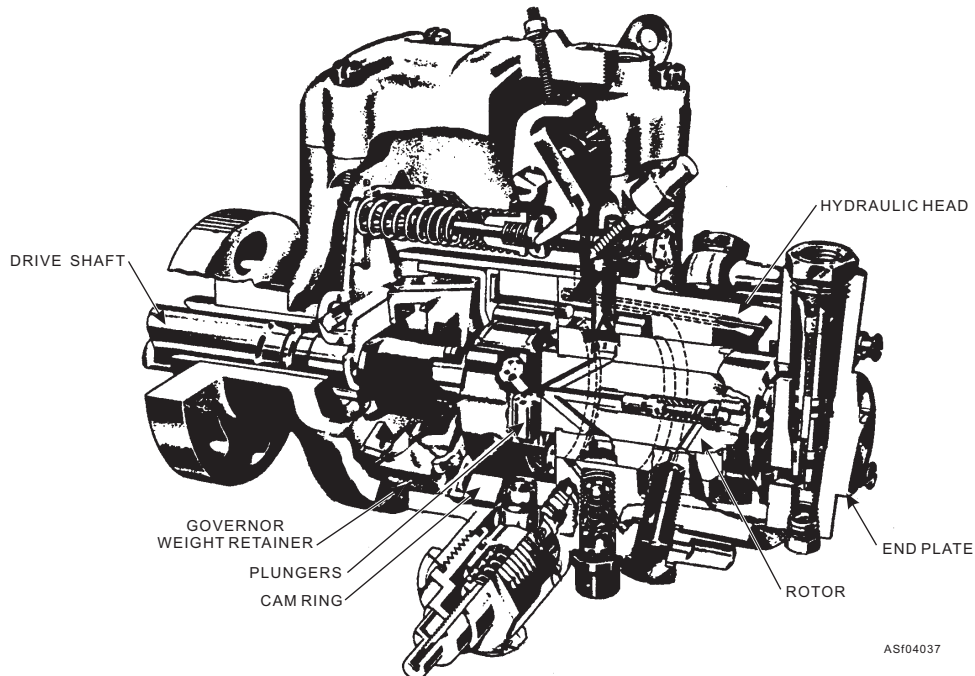

Figure 4-37.—Roosa Master fuel injection pump (Model DC).

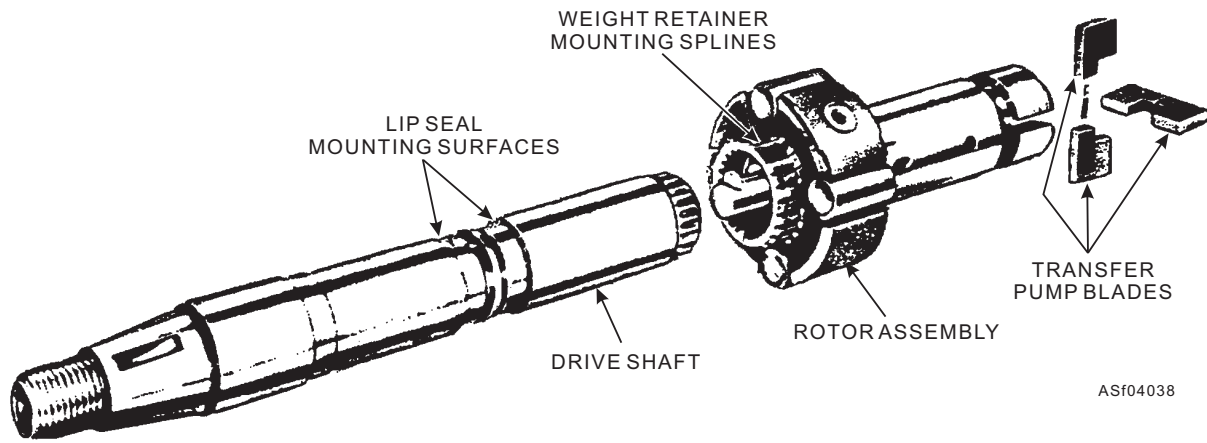

Figure 4-38.—Pump rotating parts (Model DC).

pressed into the housing. The splines at the rear end of the shaft engage the internal splines in the front of the rotor and turn the rotor with the shaft. A lip-type seal prevents the entrance of engine oil into the pump, and another retains the fuel used for pump lubrication. The governor weight retainer is supported on the forward end of the rotor that is externally splined.

The rotor contains the four pumping plungers, two in each of the two pumping cylinders. Slots in the rear end of the rotor provide a place for the two spring-loaded transfer pump blades (fig. 4-38). These blades turn inside a pump liner and develop the necessary pressure to charge the pumping cylinders.

The mechanical flyweight variable speed-type governor (fig. 4-39) is mounted on the drive end of the distributor rotor. The action of the weights in their retainer is transmitted through a sleeve to the governor arm, and through a linkage to the metering valve. The

governed engine speed is the speed at which the force of the governor springs is balanced on the governor arm pivot shaft. The pressure of the springs on the governor arm can be varied with the throttle shaft lever, thus providing variable governed engine speed. The idling spring provides sensitive governor action at low engine speeds. A governor linkage hook, connected to the metering valve, is actuated by the governor arm.

The drive end of the Model DC rotor has two bores that contain two plungers each. In the DC rotor, the shoe that provides a large bearing surface for the roller is carried in guide slots in the distributor rotor. The rotor shaft rotates with a very close fit in the hydraulic head. A passage through the center of the rotor shaft connects the pumping cylinder with one charging port and one discharge port. The hydraulic head, in which the rotor shaft turns, has six charging ports and six discharge ports.

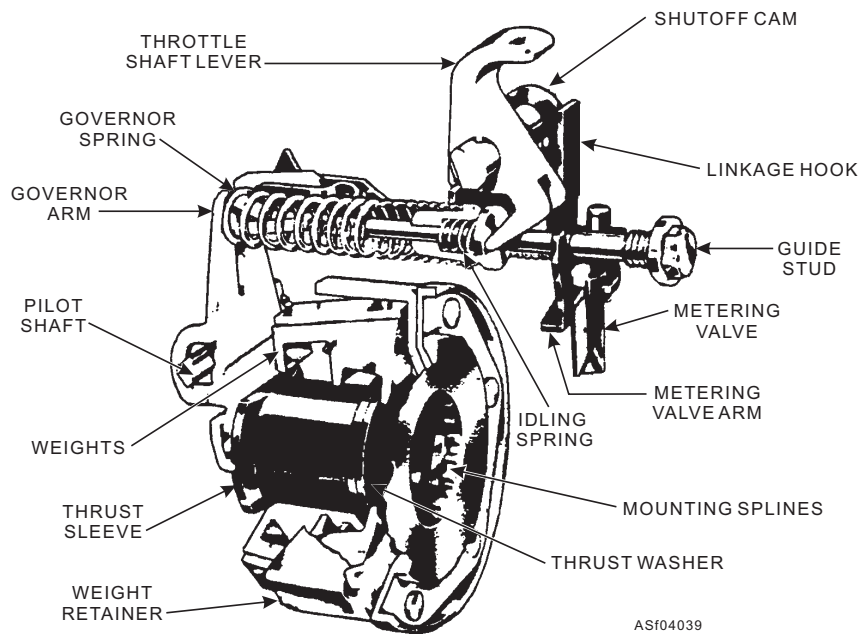

Figure 4-39.—Governor assembly (Model DC).

A positive displacement, vane-type fuel transfer pump is mounted at the end of the rotor shaft. Fuel pressure developed by the fuel transfer pump is controlled by a pressure regulator valve in the pump end plate. A passage at the top of the transfer pump aids in removal of air introduced in the system. This passage connects with the pump housing through the fuel return line to the supply tank.

Fuel is drawn from the final filter into the pump through the inlet strainer (fig. 4-40) by the vane-type fuel transfer pump. The fuel transfer pump capacity greatly exceeds the fuel required for injection; therefore, a large percentage of the fuel from the pump is bypassed through the pressure-regulating valve to the inlet side of the pump. The quantity of fuel bypassed increases as the pump speed increases. The bypass pressure also increases with speed.

Fuel not bypassed by the regulating valve passes through a hydraulic head passage to the metering valve. Fuel is metered by the metering valve in a quantity determined by engine demand.

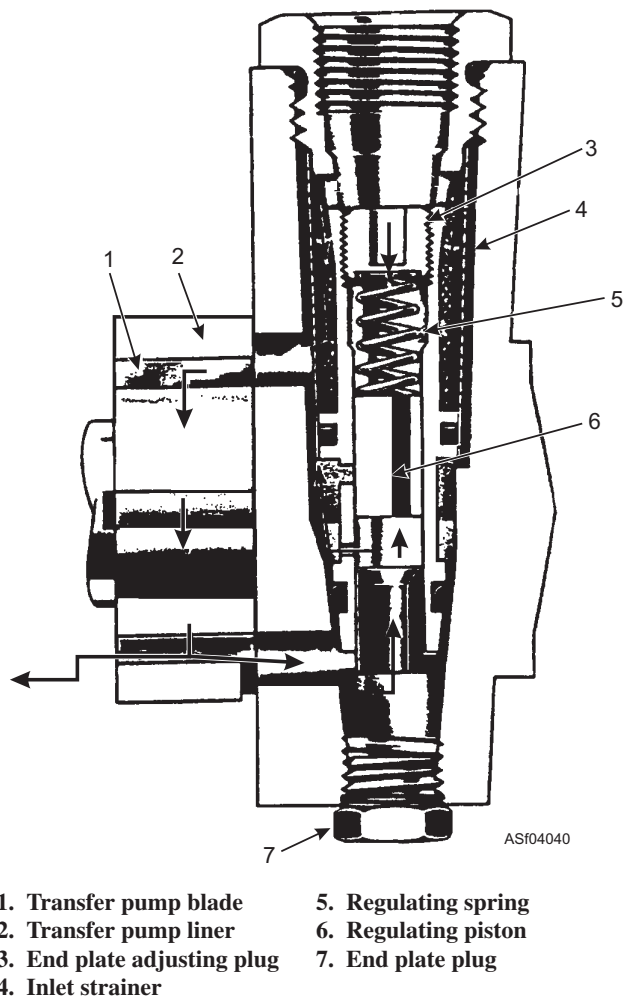

Figure 4-40.—Transfer pump (Model DC).

As the rotor revolves, its charging port registers with one of six charging ports in the head. This rotor charging port connects perfectly to the pumping cylinder and axial passage of the rotor.

As the fuel enters the pumping cylinder, the plungers are forced outward, a distance proportionate to the quantity of fuel to be injected. The quantity of fuel entering the pumping cylinder is controlled by the fuel pressure at the charging ports, time available for charging, and total plunger displacement available as limited by the leaf spring.

Fuel pressure at the charging ports is controlled by the metering valve and by the transfer pump pressure, which varies with engine speed. The time available for charging is the length of time the charging port in the hydraulic head remains in register with the charging port of the rotor. The length of time the charging port remains in register depends entirely on engine speed. The maximum amount of fuel that can be injected is limited by maximum outward travel of the plungers. This maximum plunger travel is limited by the roller shoes contacting the adjustable leaf spring stop. At the time when the charging ports are in register, the rollers are between the cam lobes (fig. 4-41); therefore, their outward movement is unrestricted during the charging cycle except as limited by the leaf spring.

The fuel is trapped in the cylinder for a very slight interval of time after charging is complete. The charging port of the rotor has passed out of register with a charging port, and the head and the rotor discharge port has not yet come into register with an outlet port of the hydraulic head.

Further rotation of the rotor brings its discharge port into register with an outlet passage in the hydraulic

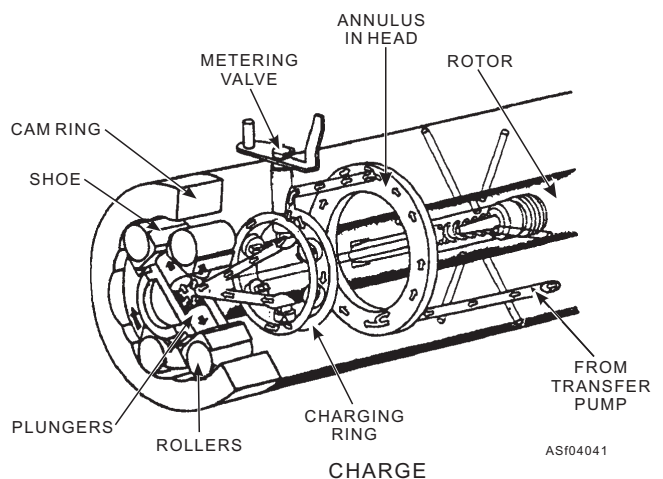

Figure 4-41.—Rotor in charging position with the rollers between the cam lobes (DC pump).

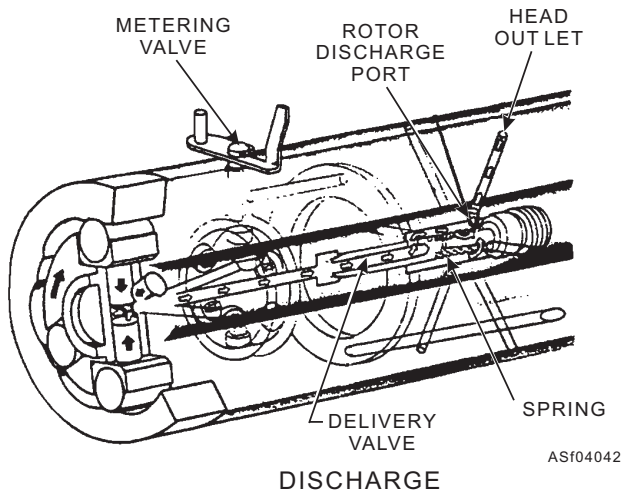

Figure 4-42.—Rotor in discharge position (DC pump).

head, at which time the rollers simultaneously contact the opposing cam lobes. The cam lobes force the plungers toward each other, discharging the fuel from the cylinder through the outlet port into the outlet passage in the hydraulic head and the fuel injection line connected to this passage (fig. 4-42). The cam is relieved to allow a slight outward movement of the roller before the discharge port is closed off. This action drops the pressure in the injection line enough to give sharp cutoff injection and prevent nozzle dribbling.

A displacement type delivery valve (fig. 4-42) is located in the drive passage of the rotor between the charging port and the discharge port of the rotor. It remains closed during charging and opens under high pressure as the plungers are forced together. Its purpose is to aid, by injection line pressure relief, the cam "retraction" previously described. Two small grooves

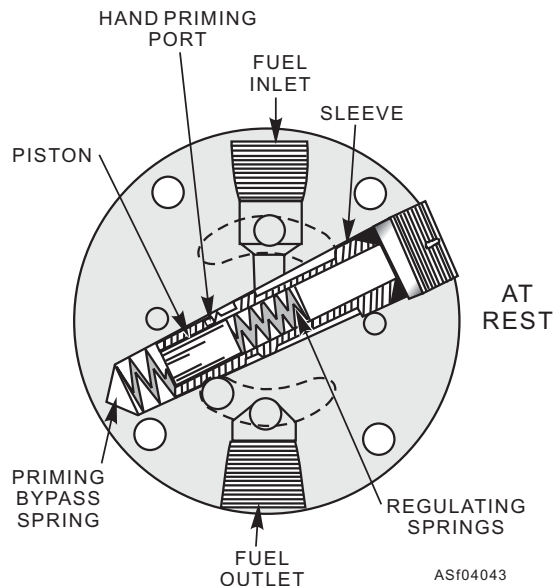

Figure 4-43.—Regulating piston at rest.

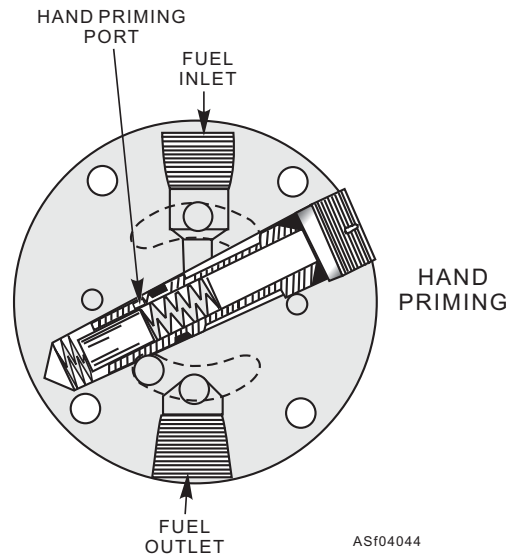

Figure 4-44.—Regulating piston during hand priming.

are located on either side of the charging port of the rotor near its flange end. These grooves carry off fuel from the hydraulic head charging ports to the housing. This flow of fuel lubricates the cam, rollers, governor parts, etc. The fuel flows through the entire pump housing, absorbs heat, and is allowed to return to the supply tank through a fuel return line connected to the pump housing cover, thus providing for pump cooling.

The end plate functions to provide passages for fuel and to cover and absorb end thrust of the transfer pump, to house the pressure regulator valve, and to house the priming bypass spring, which permits fuel to bypass the transfer pump during hand priming.

Figures 4-43, 4-44, and 4-45 show the regulating piston in three positions: at rest, during hand priming, and in operation. Figure 4-43 shows the piston covering

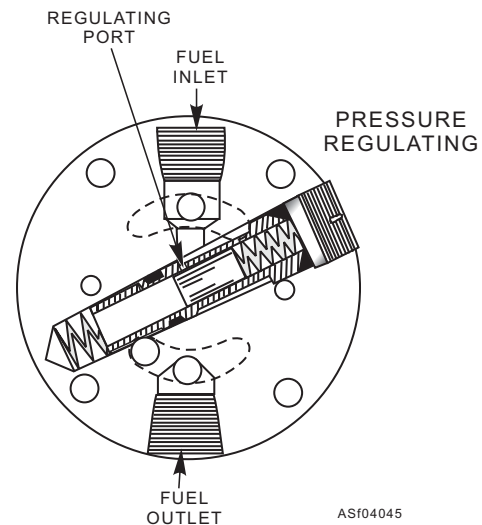

Figure 4-45.—Regulating piston in pressure regulating position.

the hand priming port and resting against the priming bypass spring. During hand priming, the pressure differential across the transfer pump, caused by the hand primer, forces the piston down, compressing the spring until the priming port (fig. 4-44) is uncovered. Fuel bypasses the stationary transfer pump to fill the system.

When the piston is in the pressure regulating position, fuel forces the piston up the sleeve until the regulating port or ports (fig. 4-45) are uncovered. Since the pressure on the piston is opposed by the regulating spring, the delivery pressure of the transfer pump is controlled by the spring rate, size, and number of regulating ports.

The torque delivered by an engine increases progressively with a decreasing rpm caused by an overload. The torque continues to increase until it reaches its peak at a certain predetermined engine speed. This desirable engine feature is called torque backup. The torque backup, when the engine is overloaded, is caused primarily by the following three factors:

- More time is available for combustion of fuel.
- Volumetric efficiency increases as engine speed decreases.
- Engine friction losses (and accessory loads) decrease with engine speed.

Since volumetric efficiency increases with decreasing engine speed, more fuel can be injected and burned at the reduced engine speed, thus increasing the torque output.

To fully explain how torque control is accomplished when the pump is properly adjusted, it is necessary to use an example, starting with a condition where the engine is operating at high idle speed, and then progressively load the engine until engine rpm drops to peak torque speed.

When the engine is operating at high idle speed with no load, the quantity of fuel delivered is controlled by governor action on the metering valve. Torque screw and leaf spring adjustment have no effect under this condition.

As load is progressively applied, the governor action on the metering valve continues to control the quantity of fuel delivered until engine rpm drops to rated load speed. At this point, the governor has opened the metering valve enough to bring an arm on the valve into contact with the torque screw, which prevents further opening of the metering valve. The maximum

amount of fuel that can be injected at rated load speed is controlled by the torque screw; leaf spring adjustment has no effect.

As overload is progressively applied to the engine, the governor continues to hold the metering valve arm in contact with the torque screw; therefore, the metering valve does not move during overload operation. However, fuel delivery increases as the engine speed drops because the charging ports remain in register for a greater length of time because of slower engine speeds. This allows more time for the charge of fuel to pass through the metering valve, which is stationary; thus charging the cylinder with a larger quantity of fuel.

As the engine speed continues to drop and reaches a speed at which maximum torque is developed, the charge of fuel becomes great enough to force the plungers outward far enough during each charging cycle to bring the roller shoes into contact with the leaf spring. This prevents further outward movement of the plungers; therefore, it limits the maximum amount of fuel that can be injected. From this you can see that the maximum amount of fuel that can be injected during overload operation below peak torque is controlled by the leaf spring adjustment.

In the DC pump, the speed advance mechanism provides controlled movement of the cam in the pump housing to advance injection at high speeds. The rising fuel pressure from the transfer pump increases flow to the power side of the advance piston (fig. 4-46). This flow from the transfer pump passes through a cut on the metering valve, through a passage in the hydraulic head, and then by the check valve in the drilled bottom head locking screw. The check valve provides a

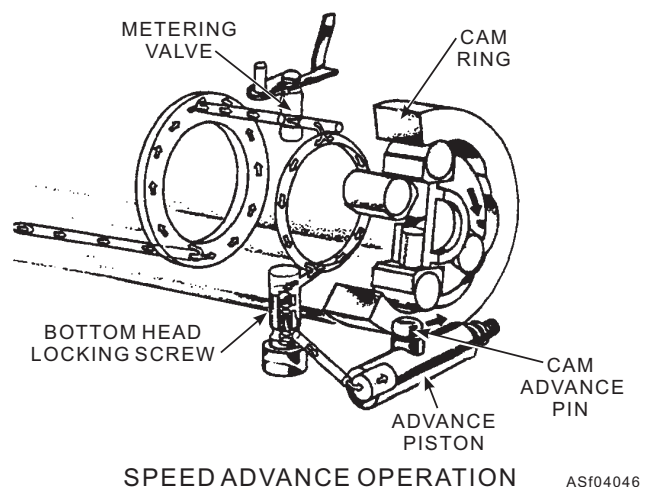

Figure 4-46.—Fuel flow in speed advance operation.

hydraulic lock, preventing the cam from retarding during injection. Fuel is directed by a passage in the advance housing end plug to the pressure side of the advance piston. The piston moves the cam counterclockwise (opposite to the direction of pump rotation). The spring-loaded side of the piston balances the force of the power side of the piston and limits the maximum movement of the cam. Therefore, with increasing speed, the cam is advanced and, with decreasing speed, it is retarded.

DISTRIBUTION PRESSURIZED INJECTOR NOZZLE.—The distribution pressurized types have either a high-pressure pump that discharges fuel in a common header to which each fuel injector nozzle is connected by tubing, or individual high-pressure pumps for each cylinder connected to the fuel injector nozzle by tubing. In either case, the injector nozzle does not furnish the pressure necessary to overcome the cylinder pressure and spray the fuel into the cylinder, but only meters and times the fuel injection. A spring-loaded bypass valve on the header or on the line to the injector nozzle maintains a constant pressure and returns the excess fuel to the supply tank.

The spray or injection nozzle extends from the top of the cylinder head down into the combustion area. It

consists of a multi-hole spray tip, a valve seat, and a needle valve extending the full length of the nozzle and head to its seat, which is supported by a spring. The high pressure is conducted from the fuel line to the spray tip immediately above the valve seat. When the valve needle is lifted vertically from its seat, fuel is sprayed into the combustion chamber.

In both the distribution pressurized type and the unit injection type of fuel injection systems for diesel engines, the pumps and injector nozzle are operated by cam-actuated mechanisms similar to the valve lifting mechanisms of internal combustion engines.

UNIT INJECTOR SYSTEM.—The unit injector system combines the pump and the nozzle in one housing. There is one unit injector per cylinder (fig. 4-47).

The fuel first passes through a primary filter located between the fuel tank and the transfer pump, which may be of either the gear or the vane type. On the discharge side of this pump is a secondary filter. Both filters have a drain cock at the bottom of the housing for removing water and dirt separated from the fuel. From the filter the fuel passes to the fuel manifolds. The lower manifold is the inlet, from which the fuel flows into the injector.

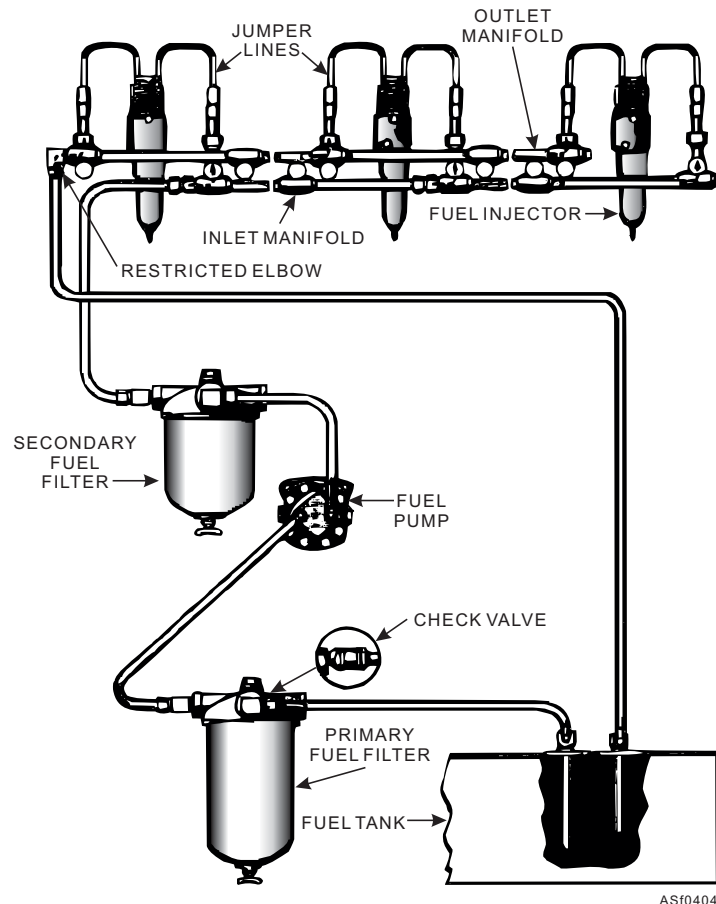

Figure 4-47.—Diagram of typical General Motors diesel fuel system.

Each injector is fitted into a water-cooled copper tube in the cylinder head and is held in place by an injector clamp. It is operated by a push rod and rocker arm. As the rocker arm forces the plunger down, the upper helix closes the upper port, and fuel injection begins. The upper helix and a lower helix are machined into the lower end of the plunger for metering purposes. The relation of these helices to the ports changes with the rotation of the plunger. As the plunger moves downward, a portion of the fuel trapped in the bushing under the plunger is displaced through the lower port back into the supply chamber, until the port is closed off by the lower end of the plunger. A portion of the fuel still trapped under the plunger is then forced upward through the central passage of the plunger into the recess between the two helices, and then into the supply chamber through the upper port, until the upper helix closes that port. With the upper and lower ports closed, the remaining fuel trapped under the plunger is subjected to increased pressure by the continued downward movement of the plunger. When sufficient pressure is built up, the injector valve is lifted off its seat and the fuel is forced through small orifices in the spray tip and atomized into the combustion chamber. The rotation of the plunger, by moving the rack, changes the position of the helices and retards or advances the closing of the ports and the beginning and ending of the injection period. Fuel injection ends when the lower helix opens the lower port. The remaining fuel then proceeds through the upper manifold, or outlet, back into the tank.

To properly time an injector, adjust the injector follower to a definite height in relation to the injector body (fig. 4-48). This will vary according to the size of the injector being used. Check the manufacturer's manual to determine the proper gauge to use.

COLD WEATHER STARTING DEVICES

Diesel fuel evaporates much slower than gasoline and requires more heat to cause combustion in the engine's cylinders. For this reason, preheating devices and starting aids are found on all Navy equipment using diesel engines. These devices and starting aids either heat the air before it is drawn into the cylinder or allow combustion at a lower temperature than during normal engine operation.

Preheaters

Preheaters, the most common type of heating device, are installed in the intake manifold or, in the

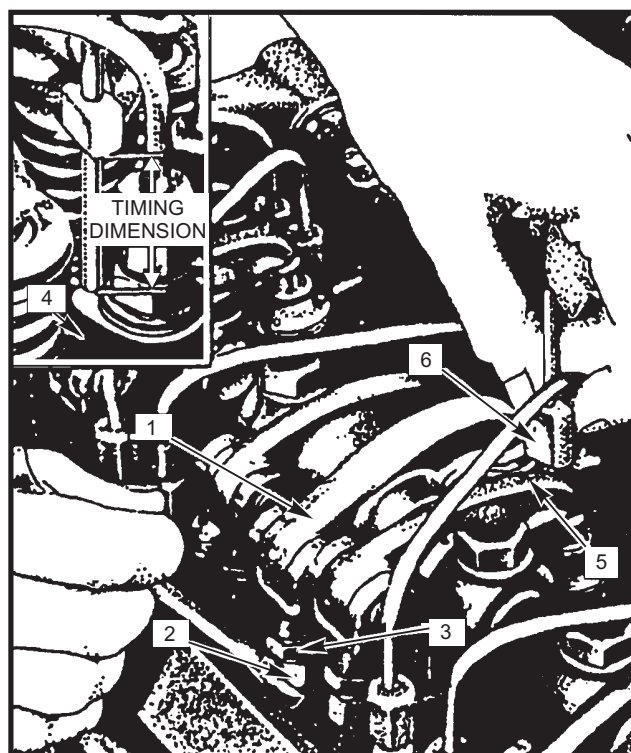

ASf04048

- | | |
|------------------------|--------------------------|
| 1. Rocker injector arm | 4. Fuel injector |
| 2. Push rod | 5. Injector follower |
| 3. Locknut | 6. Injector timing gauge |

Figure 4-48.—Timing fuel injectors.

case of 2-stroke cycle engines, are placed in the air passages surrounding the cylinders. The preheater burns a small quantity of diesel fuel in the air prior to the air being drawn into the cylinders. This burning process is accomplished by the use of either a glow plug or an ignition coil, which produces a spark to ignite a fine spray of diesel fuel. The resulting heat warms the remaining air before it is drawn into the cylinders.

Glow Plugs

Glow plugs (fig. 4-49) are installed directly in the precombustion or turbulence chamber of the cylinder head. The injection nozzle is also in this chamber. When you crank the engine, the glow plug is turned on. The heat created by electrical resistance in the glow plug heats the fuel and air mixture. Heat generated by the glow plug permits burning of the fuel in the chamber and cylinder.

Starting Fluid

Starting fluid, in either an aerosol container or capsule, is frequently used as a starting aid. This fluid is a highly volatile fluid (ether or a suitable substitute),

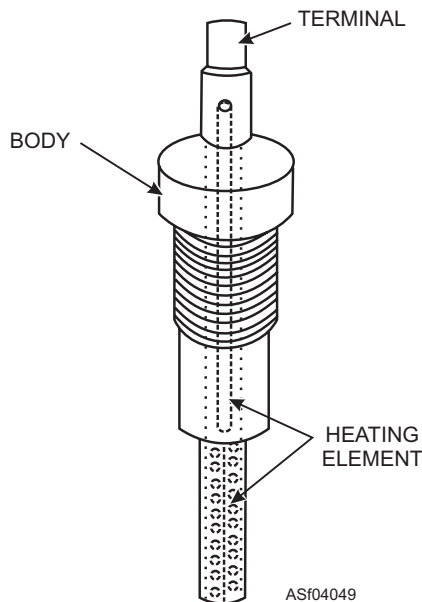

Figure 4-49.—Glow plug.

which is injected into the intake manifold as you crank the diesel engine. Since ether has a low ignition point, the heat generated in the combustion chamber is able to ignite it. Heat from this ignition then ignites the diesel fuel and normal combustion takes place. Once the diesel engine starts, no more fluid is needed.

When using cold weather starting aids, be sure to follow the manufacturer's instructions to prevent damage to the engine or the starting aid.

Q4-26. Fuel injector pumps require assistance to transfer fuel from the supply tank to the injector pumps from which of the following components?

1. An injection metering device
2. A pressure regulator
3. A boost pump
4. A supply pump

Q4-27. Gear and vane type pumps are two classifications of what type of fuel pumps used on a diesel engine?

1. Boost pumps
2. Injection pumps
3. Supply pumps
4. Metering pumps

Q4-28. Which of the following terms is use to describe the process of breaking up of the fuel into small particles as it enters the cylinder?

1. Timing
2. Injection
3. Atomization
4. Metering

Q4-29. The purpose of the distribution pressurized injector nozzle is to perform which of the following functions?

1. It meters and times the fuel injection
2. It creates fuel pressure to be injected into the cylinder
3. It store excess fuel until it is needed for injection
4. It limits the amount of fuel to the cylinder during off-load conditions

Q4-30. The unit injector system is operated by which of the following components?

1. By the cam shaft rotation
2. By the push rod and rocker arm
3. By the crank shaft rotation
4. By the hydraulic lifters

Q4-31. Prior to the air being drawn into the cylinder of a diesel engine, the purpose of the pre-heater is to perform which of the following functions?

1. Warm the air with an electric coil
2. Pre-ignite the fuel prior to it entering the cylinder
3. Warm the air by using engine heat prior to it entering the cylinder
4. Burning a small amount of the diesel fuel in the air prior to the air entering the cylinder

Q4-32. Where in a diesel engine are the glow plugs located?

1. In the intake manifold
2. In the combustion chamber
3. In the precombustion chamber
4. In the heads next to the intake valves

Q4-33. During cold weather starting of a diesel engine, into what part of the engine is starting fluid injected?

1. The precombustion chamber
2. The combustion chamber
3. The intake manifold
4. The injector nozzle

DIESEL FUEL SYSTEM MAINTENANCE

LEARNING OBJECTIVES: Identify procedures for inspecting, checking, testing, and adjusting diesel engine fuel systems. Identify procedures for troubleshooting diesel engine

fuel systems. Identify procedures for repairing, removing, and replacing diesel engine fuel system components.

Many of the diesel engines in support equipment are required to operate for long periods of time under heavy loads. These engines are designed for this type of use and can withstand it, provided they receive proper service and maintenance. Most of the servicing and maintenance requirements are simple, but nonetheless important. Servicing the diesel engine includes the replenishment of fuels, lubricants, and coolants, and in some arrangements, hydraulic fluids and other consumable materials. Maintenance is required to keep the diesel engine in an optimum operating condition.

The similarity of the diesel and the gasoline engine is often pointed out, but in many ways they are dissimilar. This should be kept in mind during service and maintenance of the engine. If there is any doubt as to what you should do, consult the manufacturer's manual or other authorized publications.

GENERAL SERVICING AND MAINTENANCE

Diesel engine servicing is normally done on a preoperational or periodic inspection and is performed in accordance with the MRCs (maintenance requirements cards). These cards usually contain only minimum requirements; therefore, it is the responsibility of the work center supervisor to review the cards and add additional requirements that are of importance to the particular equipment in his operating environment.

The materials or products for servicing the diesel engine should be properly stored and kept free of contamination. A contaminated product may be rendered completely useless, or it may cause more damage than if the equipment was not serviced at all.

In servicing the diesel engine, you should use only those materials or products recommended by the manufacturer or those that have been authorized as a substitute by higher authority. Again, the maintenance instructions for servicing, quantities, levels, etc., should be followed.

No matter how well the diesel engine is serviced and cared for, maintenance is still required to keep the engine in optimum operating condition. The maintenance performed on the engine falls into two broad categories: (1) actions taken to reduce or eliminate failure and prolong the useful life of the engine, and (2) actions taken when a part or component

has failed and the engine is out of service. Therefore, the types of maintenance consist of preventive maintenance (scheduled) and corrective maintenance (unscheduled).

Preventive maintenance is performed periodically on the engine (and on the equipment on which it is used) in accordance with the MRCs. Corrective maintenance is performed when a malfunction occurs between periods of preventive maintenance.

Because a diesel engine depends on the heat of compression for ignition and proper combustion, it is necessary for efficient operation that the engine run in the heat range specified by the manufacturer. If an engine is running too hot or too cold, check the cooling system; this includes the water pump and fan belt. It may be necessary to remove and test the thermostats. Pressure cooling systems are provided on most modern equipment. This enables an engine to operate at a higher temperature without boiling the coolant. The pressure-relief valve in the system (usually in the radiator cap) should be checked periodically. If the pressure becomes too great, there is danger of blowing a radiator hose or rupturing a tube in the radiator core.

If all diesel engines had nearly identical fuel systems (like gasoline engines) trouble diagnosis and maintenance procedures could follow a general pattern much like the one that is used for gasoline engines. But, with the exception of similar fuel tanks, filters, and a basic piping system, diesel engine fuel systems differ considerably. Consequently, each engine manufacturer recommends different specific maintenance procedures. Those described herein for the more popular diesels are by no means all you will need to know. However, the tune-up and maintenance procedures described are representative of jobs you will do. For all jobs you do not thoroughly understand, refer to the manufacturer's maintenance manual for the fuel system concerned.

DIRT IN THE FUEL SYSTEM

Many diesel engine operating troubles result directly or indirectly from dirt in the fuel system. That is why proper fuel storage and handling are so important. One of the most important aspects of diesel fuel is cleanliness. The fuel should not contain more than a trace of foreign substance; otherwise, fuel pump and injector troubles will occur. Diesel fuel, because it is more viscous than gasoline, will hold dirt in suspension for longer periods. Therefore, you should take every precaution to keep the fuel clean.

If the engine starts missing, running irregularly, rapping, or puffing black smoke from the exhaust manifold, look for trouble at the spray nozzle valves. In this event, it is almost a sure bet that dirt is responsible for improper fuel injection into the cylinder. A valve held open or scratched by particles of dirt so that it cannot seat properly will allow fuel to pass into the exhaust without being completely burned, causing black smoke. Too much fuel may cause a cylinder to miss entirely. If dirt prevents the proper amount of fuel from entering the cylinders by restricting spray nozzle holes, the engine may skip, or stop entirely. In most cases, injector or spray valve troubles are easily identified.

Improper injection pump operation, however, is not so easily recognized. It is more likely caused by excessive wear than by an accumulation of dirt or carbon, such as the spray nozzle is subjected to in the cylinder combustion chamber. If considerable abrasive dirt gets by the filters to increase (by wear) the very small clearance between the injector pump plunger and barrel, fuel will leak by the plunger instead of being forced into the injector nozzle in the cylinder. This gradual decrease in fuel delivery at the spray nozzle may remain unnoticed for some time, or until the equipment operator complains of sluggish engine performance.

Although worn injector pumps will result in loss of engine power and hard starting, worn piston rings, cylinder liners, and valves (air intake or exhaust) can be responsible for the same conditions. However, with worn cylinder parts or valves, the hard starting and loss of power will be accompanied by poor compression, a smoky exhaust, and excessive blowby from the crankcase breather.

WATER IN THE FUEL SYSTEM

It requires only a little water in a fuel system to cause an engine to miss, and if present in large enough quantities, the engine will stop entirely. Many fuel filters are designed to clog completely when exposed to water, thereby stopping all fuel flow. Water that enters a tank with the fuel, or that forms by condensation in a partially empty tank or line, usually settles to the lowest part of the fuel system. This water should be drained off daily.

AIR IN THE FUEL SYSTEM

Air trapped in diesel fuel systems is one of the main reasons for difficulty in starting an engine. Air can enter

the fuel system at loose joints in the piping or through a spray nozzle that does not close properly. When a vehicle runs out of fuel, air is able to enter the system. Like water, air can interfere with the unbroken flow of fuel from the tank to the cylinder. A great amount of air in a system prevents fuel pumps from picking up fuel and pushing it through the piping systems.

Anytime the fuel flow is depleted and air enters the fuel system, the fuel system must be primed. This process is often called bleeding the system. If air is left in the lines, the fuel system may be air-bound. This can result in an inability of the diesel engine to start or in its missing in one or more cylinders. If an engine does not start, open the main fuel line vent and crank the engine until a flow of fuel through the vent becomes continuous and contains no air bubbles. Be sure the vent is closed before attempting to restart the engine.

If one or more cylinders are missing when the engine is running, it may be necessary to open the individual vents or fuel lines leading from the injection pump to the injectors to remove the remaining air bubbles. If air continues to collect in the fuel injection system following several bleedings, the suction (vacuum) side of the fuel system needs to be checked for loose fittings or a pinhole in the lines. For complete details on the priming (bleeding) procedure, consult the equipment MIMs.

MAINTAINING INJECTION EQUIPMENT

Diesel injection equipment (injectors or spray valves and pumps) are assembled units of precision parts; they cannot be cleaned or adjusted adequately except in the work center. To operate efficiently, they must be cleaned, repaired, and adjusted with special equipment.

When fuel injection troubles are suspected, and before removing the injector nozzles for shop testing, it is a good practice to check the injectors to find out if just one of them is causing the trouble. To do so, first operate the engine at a speed at which the defect is more pronounced. While the engine is operating at this speed, loosen the fuel line connection at each injector one at a time to "cut out" the cylinder. When you find one that makes very little or no difference in the irregular operation of the engine, the injector for that cylinder is probably causing the trouble and needs to be removed and tested. It is seldom that one injector valve alone is responsible for all the trouble. Therefore, you should continue the testing until all injectors have been tested.

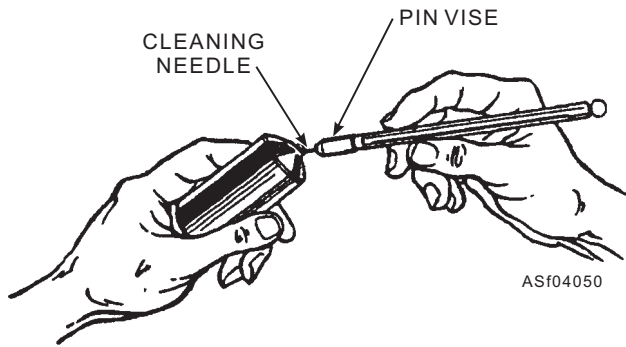

Figure 4-50.—Cleaning injector spray nozzle holes.

NOTE: Because of the physical location of the unit injectors under the valve covers, and because the dripping fuel from a loosened injector line would drain down into the crankcase, the above test cannot be performed on a GM diesel. To test a GM diesel injector, the valve cover must be removed and each unit injector follower depressed one at a time with a screwdriver or similar device. This will isolate each injector to determine if it is faulty.

If an injector appears to be faulty, you can check its performance with a nozzle tester. This instrument may be used without taking the injector apart. Nozzle testers all work on the same principle. The injector is connected to a hand pump with which you force fuel through the injector. A pressure gauge is attached to the pump so that you can note the opening (cracking) pressure at which the injector is set. You can easily test for leakage and see the spray pattern as the fuel comes out of the injector. Ensure eye protection is worn and all body parts are protected from the high-pressure spray.

Cleaning Injectors

Unless special servicing equipment and repair instructions are available, defective nozzles and pumps are usually exchanged for new ones. However, in an emergency, and if spray valves or pumps are not too badly worn, they may be returned to a serviceable condition, with minor adjustment, after a thorough cleaning.

Injector spray nozzles or pumps should never be disassembled in the field. They should be removed from the equipment and brought to the shop for repair. The first requirement for the cleaning job is a clean working space.

Use clean diesel fuel for washing the parts. Disassemble one nozzle or pump assembly at a time to prevent mixing of mating parts. Exercise care to prevent damage to nozzle and pump parts. Inspect and clean all parts as they are disassembled. Carbon may be scraped from the outside of the nozzle, but be careful not to mar the edges of the holes (orifices). When cleaning fluid is used to clean pump and nozzle parts, dip the parts in diesel fuel immediately after cleaning. This will prevent moisture from the hands from marring the highly polished surfaces.

Reaming tools and special drills are provided for cleaning spray nozzle holes. No drills other than those recommended by the manufacturer should be used. The drills are hand operated, and the smaller, needle-type drill should be held with a small chuck called a pin vise (fig. 4-50).

In performing reaming operations, remove only the foreign matter; be particularly careful not to burr the metal.

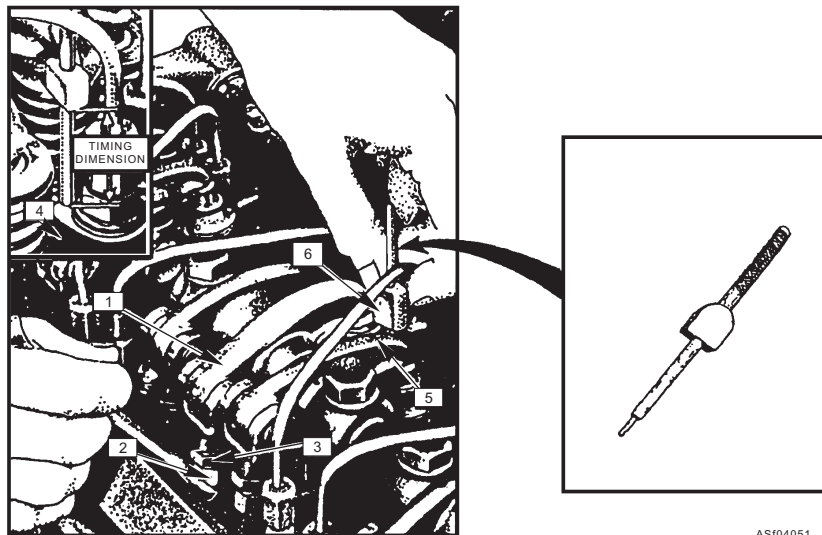

- | | | |
|------------------------|------------------|--------------------------|
| 1. Rocker injector arm | 3. Locknut | 5. Injector follower |
| 2. Push rod | 4. Fuel injector | 6. Injector timing gauge |

Figure 4-51.—Timing fuel injectors with injector timing gauge.

Injector Timing

Whenever a General Motors 53 or 71 series diesel engine injector has been removed and reinstalled, or a new injector has been installed, the injector must be timed and the injector control rack positioned.

To properly time an injector, adjust the injector follower to a definite height in relation to the injector body (fig. 4-51). This will vary according to the size of the injector being used. Check the manufacturer's manual to determine the proper gauge to use.

Place the engine speed control lever to the shutoff position and rotate the crankshaft in the direction of engine rotation until the exhaust valves are fully depressed on the particular cylinder to be timed. Place the small end of the injector timing gauge in the hole provided in the top of the injector body. Loosen the pushrod locknut, turn the pushrod, and adjust the injector rocker arm until the extended part or shoulder of the gauge will just pass over the top of the injector follower. Hold the pushrod and tighten the locknut. Check adjustment after tightening the locknut and readjust as necessary. By following the sequence of the engine firing order, you can time the injectors in one revolution of the crankshaft.

Equalizing Injectors

Equalizing injectors means to adjust the injector racks so that all injectors in an engine inject the same amount of fuel at any given engine speed. This is done by adjusting the inner and outer adjusting screw on the rack control lever (fig. 4-52). This is a rather delicate adjustment to make. To equalize the injectors on the common 53 or 71 series GM diesels used in today's QEC kits, all inner and outer injector rack control lever adjusting screws must be loosened. Move the speed

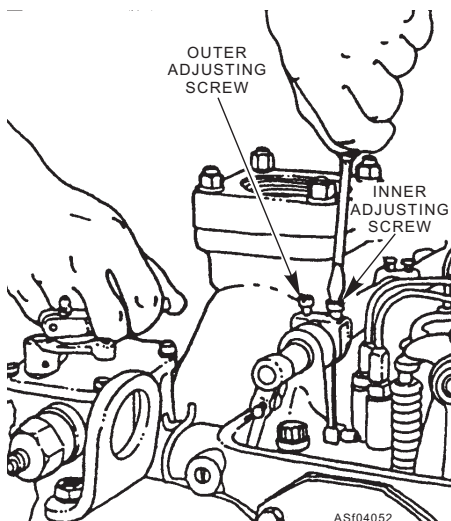

Figure 4-52.—Positioning rear injector rack control lever.

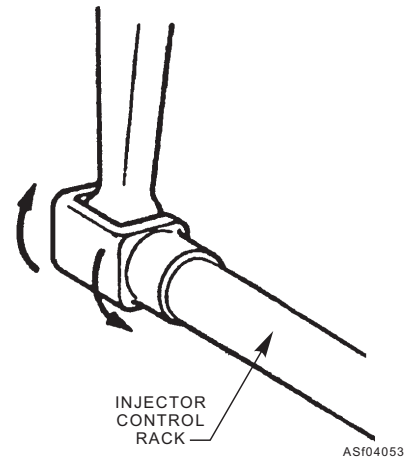

Figure 4-53.—Checking rotating movement of injector control rack.

control lever to the full fuel position, and hold it in that position with light finger pressure. Turn the inner adjusting screw on the rear injector rack control lever down until a slight movement of the control lever is observed. This will place the rear injector rack in the full fuel position. Turn down the outer adjusting screw until it bottoms lightly on the control tube. Then, alternate tightening of the inner and outer adjusting screws. Torque both to 24 to 36 inch-pounds.

To check the proper adjustment, hold the speed control in the full fuel position and press down on the injector rack with a screwdriver. Note the rotating movement of the rack (fig. 4-53). Holding the rack in the same full fuel position, push downward on the injector control rack with the screwdriver (fig. 4-54). The rack should tilt downward and then spring back

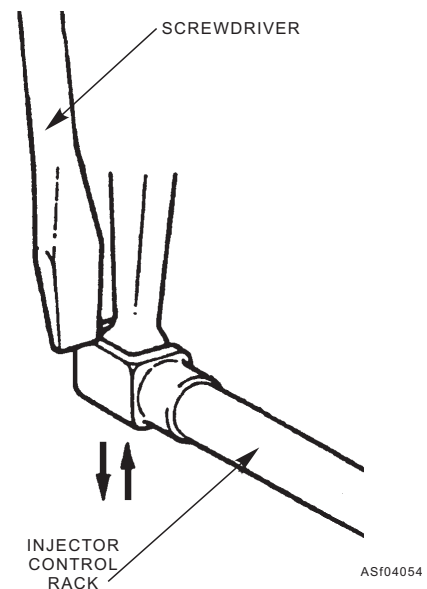

Figure 4-54.—Checking injector rack “spring” action.

upward when the screwdriver is removed. If it does not return to its original position, it is too loose. If the rack becomes tight before the full travel, it is too tight. In either case, readjust to obtain the proper feel.

Once the rack is adjusted for the rear injector, begin adjusting the next injector forward. Once it is adjusted, go back to the last injector and check it again. Continue working forward using this method of rechecking the previously adjusted injectors until all are properly set. Lastly, check the rack for free movement from minimum speed position through maximum speed position without an increase in effort toward the end of the travel.

When calibrated injectors are used, the manufacturer's method of equalizing racks should be followed. It may be necessary to make these adjustments several times before the engine runs just right.

Sometimes smoother engine operation can be obtained by making slight changes to the equalizing adjustments after the engine is warmed to operating temperatures (above 140°F). For example, one cylinder may not be carrying its share of the load as indicated by a comparatively cooler cylinder. Its control rack, therefore, should be adjusted for more fuel. A slight knocking noise from another cylinder would indicate an adjustment for a slightly smaller amount of fuel.

To increase the amount of fuel injected, loosen the outer adjusting screw and tighten the inner screw,

thereby moving the control rack inward. To decrease fuel injection, loosen the inner adjusting screw slightly and tighten the outer screw, which moves the control rack outward. In making these operating adjustments, never turn the adjusting screws more than one-fourth turn at a time. If one injector is adjusted too far out of line with the others, it will prevent the full travel of the racks and reduce the maximum power of the engine.

Do not attempt to obtain a smooth running engine by changing control-rack settings without first timing and equalizing injection in the recommended manner.

TROUBLESHOOTING

Diesel engines have higher compression pressures, compression temperatures, and compression ratios than gasoline engines; therefore, diesel engines must be of a heavier and stronger construction. Even with stronger built engines, good servicing, and maintenance, the diesel engine develops malfunctions. When these malfunctions occur, troubleshooting must be performed to locate the cause so corrective action can be taken to get the engine back to its top performance.

Some of the test equipment and troubleshooting practices and procedures used on gasoline engines may also be used on diesel engines, but some of the systems require special test equipment and different troubleshooting practices and procedures. Table 4-1 lists a few

Table 4-1.—Diesel Engine Troubleshooting Chart

TROUBLE	PROBABLE CAUSE	REMEDY
ENGINE STARTING		
Engine does not rotate.	Starter/transmission binding. Engine seized.	Repair starter or transmission. Replace engine. (Refer to QEC instructions.)
Starting motor does not crank the engine.	Batteries discharged. Loose or corroded electrical connections. Defective control switch, starting contactor, solenoid switch, or interlock switch. Battery damage, punctured case, or loose terminal posts. Starter motor brushes worn out. Starter motor windings defective (shorted or open). Starter drive assembly damaged.	Test battery cells. Service or replace as required. Clean dirty or corroded connections. Tighten connections. Refer to wiring diagrams for circuit description and component location. Replace defective parts. Replace battery. Repair or replace starter motor. Replace starter motor. Replace starter motor.

Table 4-1.—Diesel Engine Troubleshooting Chart—Continued

TROUBLE	PROBABLE CAUSE	REMEDY
<p>Starter operates but engine won't start.</p>	<p>Fuel inadequate for combustion.</p> <p>Injectors clogged.</p> <p>Injector timing wrong.</p> <p>Engine stop solenoid stuck in stop position.</p> <p>Governor stop lever stuck in stop position.</p> <p>Air entering fuel lines between fuel pump and fuel tank.</p> <p>Fuel system priming lost (if tractor ran out of fuel).</p> <p>Air inadequate for combustion.</p> <p>Emergency shutdown valve closed.</p>	<p>Test fuel pump drive.</p> <p>Check supply at tank.</p> <p>Check fuel cutoff valve.</p> <p>Change fuel filter.</p> <p>Test fuel pump volume output.</p> <p>Test fuel system pressure.</p> <p>Drain contaminated fuel from system.</p> <p>Service injectors.</p> <p>Correct injector timing.</p> <p>Check electrical stop circuit.</p> <p>Service governor linkage. Check solenoid.</p> <p>Check hoses and hose connections for ruptures.</p> <p>Check fuel strainer gasket for air leak.</p> <p>Prime fuel system.</p> <p>Check air cleaner.</p> <p>Reset emergency shutdown valve.</p>
<p>ABNORMAL ENGINE OPERATION</p>		
<p>Uneven running or stalling:</p> <ul style="list-style-type: none"> • When temperature remains below 170 degrees. 	<p>Cylinder misfire.</p> <p>Thermostat open.</p>	<p>Test cylinder misfiring.</p> <p>Replace thermostat.</p>
<p>Consistently.</p> <ul style="list-style-type: none"> • At acceleration. 	<p>Exhaust valve and/or injector timing fault.</p> <p>Fuel contaminated.</p> <p>Fuel inadequate due to faulty injector(s).</p> <p>Fuel pressure low.</p> <p>Exhaust valves not closing.</p>	<p>Perform turn-up.</p> <p>Drain fuel tanks, add specified fuel.</p> <p>Service injectors.</p> <p>Test fuel pressure.</p> <p>Adjust valves.</p> <p>Test cylinder compression.</p>

Table 4-1.—Diesel Engine Troubleshooting Chart—Continued

TROUBLE	PROBABLE CAUSE	REMEDY
<ul style="list-style-type: none"> • With coolant loss. • At high engine speed or with load. 	<p>Coolant entering cylinder.</p> <p>Insufficient fuel.</p> <p>Air in fuel.</p> <p>Injector filter clogged.</p> <p>Injector rack levers out of adjustment.</p> <p>High exhaust back pressure.</p> <p>Restricted air intake.</p> <p>Governor to injector rod movement restricted.</p> <p>Injector control tube and lever assembly faulty.</p>	<p>Torque head bolts.</p> <p>Correct fuel flow.</p> <p>Test fuel system for air leaks.</p> <p>Test injector filters.</p> <p>Adjust injector rack control levers.</p> <p>Test exhaust back pressure.</p> <p>Eliminate restriction in exhaust system.</p> <p>Test air inlet restriction.</p> <p>Check blower screen for obstruction.</p> <p>Service or replace air filter as required.</p> <p>Correct governor to injector rod operation.</p> <p>Replace faulty parts.</p>
<p>Detonation.</p>	<p>Lube oil leak into cylinder(s).</p>	<p>Test cylinder compression. Eliminate oil leak.</p>
<p>Exhaust smoke black-gray.</p>	<p>Air inadequate for complete fuel burn.</p>	<p>Eliminate cause of excessive exhaust back pressure.</p> <p>Eliminate restriction of fresh air intake at:</p> <ul style="list-style-type: none"> Air filter. Intake housing screen. Cylinder liners. Shutdown valve. <p>Correct air pressure loss at:</p> <ul style="list-style-type: none"> Air intake housing gasket. Blower lobes.

Table 4-1.—Diesel Engine Troubleshooting Chart—Continued

TROUBLE	PROBABLE CAUSE	REMEDY
Exhaust smoke black-gray— Continued.	Lube oil entering combustion chambers.	Test lube system pressure. Test compression to isolate faulty cylinder(s). Torque cylinder head bolts to seal head gasket. Test air box pressure. Replace engine. (Refer to QEC instructions.)
Exhaust smoke blue.	Excess fuel or timing wrong. Wrong fuel.	Conduct tune-up. Drain fuel tanks and add specified fuel.
Exhaust smoke white.	Blower oil seal leak.	Remove air inlet housing. Check seal areas with engine running. Service blower is seal leaking. Test compression.
High oil consumption.	Piston rings leaking lube oil.	Replace engine. (Refer to QEC instructions.)
Exhaust smoke white.	Misfiring cylinder(s).	Repair injectors.
High oil consumption.	External leaks.	Tighten engine mounted components: Oil pan. Fuel pump. Air compressor. Oil cooler. Blower. Rocker arm cover. Tighten piping and external components: Filter components. Oil pan to sump hose.
	High crankcase pressure.	Test crankcase pressure.
	Cylinder blowby.	Replace engine. (Refer to QEC instructions.)
	Air from blower.	Correct blower to block gasket leak.

Table 4-1.—Diesel Engine Troubleshooting Chart—Continued

TROUBLE	PROBABLE CAUSE	REMEDY
<p>Abnormal oil pressure:</p> <ul style="list-style-type: none"> • High oil pressure. • Coolant in oil. • Low oil pressure. 	<p>Oil viscosity wrong.</p> <p>Oil filter clogged.</p> <p>Engine temperature below normal.</p> <p>Faulty head gasket.</p> <p>Faulty oil cooler.</p> <p>Faulty water pump seal.</p> <p>Cracked, damaged, or warped cylinder liner, cylinder head, or engine block.</p> <p>Low oil supply.</p> <p>Air leak in oil pump suction line.</p> <p>Oil viscosity low.</p> <p>Oil pressure gauge or sending unit defective.</p> <p>Oil pressure regulator sticking in open position.</p> <p>Oil pump screen clogged.</p> <p>Oil pump defective.</p> <p>Oil cooler bypass valve stuck closed.</p>	<p>Change oil to specified grade.</p> <p>Change oil filter element.</p> <p>Refer to Abnormal Coolant Temperature.</p> <p>Replace engine. (Refer to QEC instructions.)</p> <p>Replace damaged parts.</p> <p>Replace damaged parts.</p> <p>Replace engine. (Refer to QEC instruction.)</p> <p>Fill sump to dipstick full mark.</p> <p>Tighten oil line fittings.</p> <p>Check oil lines for breaks. Replace defective parts.</p> <p>Drain system, use oil of specified weight.</p> <p>Check oil for dilution by fuel or water. Replace defective parts.</p> <p>Replace pressure indicating defective parts.</p> <p>Clean or replace defective parts.</p> <p>Clean or replace defective part.</p> <p>Replace engine. (Refer to QEC instructions.)</p> <p>Correct oil pump flange leak.</p> <p>Clean or replace parts.</p>

Table 4-1.—Diesel Engine Troubleshooting Chart—Continued

TROUBLE	PROBABLE CAUSE	REMEDY
<p>Abnormal engine temperature:</p> <ul style="list-style-type: none"> • High temperature. 	<p>Insufficient heat transfer.</p> <p>Thermostat not opening.</p> <p>Coolant circulation inadequate.</p> <p>Air circulation through radiator inadequate.</p> <p>Loss of coolant.</p>	<p>Test cooling system temperature.</p> <p>Clean cooling system by flushing.</p> <p>Test thermostat.</p> <p>Check coolant level.</p> <p>Replace broken fan belt.</p> <p>Clean fan and radiator.</p> <p>Replace broken radiator hose.</p> <p>Correct water pump gasket leak.</p> <p>Torque head bolts.</p> <p>Replace engine. (Refer to QEC instructions.)</p>
<ul style="list-style-type: none"> • Low temperature. 	<p>Thermostat not closing.</p>	<p>Replace thermostat.</p>

of the most common problems, the probable causes of the problems, and the remedies for correcting them. In-depth, up-to-date troubleshooting charts are included in the applicable maintenance manuals for your model engines.

Q4-34. Which of the following reasons is one of the main causes for difficulty in starting a diesel engine?

1. The injectors are clogged
2. The fuel filter is clogged
3. There is air trapped in the fuel system
4. The battery voltage is low

Q4-35. When testing a GM diesel engine injector, you must first perform which of the following tasks?

1. Loosen the fuel line to the injector
2. Remove the valve cover
3. Depress the injector with a screwdriver
4. Remove all the injectors and test them with an injector tester

Q4-36. Which of the following discrepancies is the probable cause of an abnormal operation of a diesel engine during acceleration?

1. Improper ignition timing
2. Clogged fuel injector
3. Low fuel in the unit
4. Intake valve time is incorrect

CHAPTER 5

INTERNAL COMBUSTION ENGINE COOLING AND LUBRICATING SYSTEMS

INTRODUCTION

All internal combustion engines are equipped with cooling and lubricating systems that work in conjunction with each other to promote efficient engine operation and performance. The cooling and lubricating systems discussed in this chapter, along with their respective components and maintenance requirements, are representative of the types of systems you will be expected to maintain.

Because of the variety of engines used in support equipment, there are differences in the applications of features of their cooling and lubricating systems. Keep in mind that maintenance procedures and operational characteristics vary from engine to engine; therefore, always refer to the manufacturer's instructions for specific information.

COOLING SYSTEMS

LEARNING OBJECTIVES: Identify the components of gasoline and diesel engine cooling systems. Identify procedures for inspecting, repairing, and removing and replacing gasoline and diesel engine cooling systems. Identify procedures for troubleshooting gasoline and diesel engine cooling systems.

The internal combustion engine produces power by burning fuel within the cylinders, and is sometimes referred to as a "heat engine." However, only about 25 percent of the heat is converted into useful power for propelling the vehicle or for doing other work. What happens to the remaining 75 percent of the heat? It is largely absorbed by the engine parts or passes out with the exhaust gases. If this heat were not removed quickly, overheating and extensive damage to the engine would result. Valves would burn and warp, lubricating oil would break down, pistons and bearings would overheat and seize, and the engine would soon stop.

The necessity for cooling may be emphasized by considering the total heat developed by an ordinary six-cylinder engine. It is estimated that such an engine operating at ordinary speeds generates sufficient heat to warm a six-room house in freezing weather. Also, peak combustion temperatures in gasoline engines may reach as high as 4,500°F, while that of a diesel engine may approach 5,000°F. Some of this heat is absorbed by the valves, pistons, cylinder walls, and cylinder head, all of which must be provided with some means of cooling to avoid excessive temperatures. Thus, even though very high temperatures may be reached by the heated gases, the cylinder wall temperatures must not be allowed to rise beyond 400° to 500°F. Temperatures above this will result in serious damage, as already indicated. However, for best thermal efficiency, it is desirable to operate the engine at temperatures closely approximating the limits imposed by the lubricating oil properties.

The purpose of the cooling system is to absorb and remove or transfer heat from the engine as well as regulate the operating temperature of the engine for best efficiency. About 25 percent of the heat produced in the combustion chambers by the burning of fuel is dissipated via the cooling system, along with the lubrication and fuel systems. Nearly 50 percent of the heat produced passes out with the exhaust gases. An additional function of the cooling system is that of controlling the temperature in the vehicle passenger compartment to a comfortable range in cold weather, usually through use of hot water heaters.

Air is the only thing that is continually present in large enough quantities to cool the running engine. Vehicles are designed to dissipate the heat from the engine into the air through which they pass. This is accomplished either by direct air-cooling or indirectly by liquid cooling. Thus, in the final analysis, the cooling of all automotive engines is actually air-cooling, regardless of whether they are classified as air-cooled or liquid-cooled. In this chapter we will discuss both types to include a description of the various components of the systems and an explanation of their operation.

AIR-COOLING SYSTEMS

The simplest type of cooling is the air-cooled, or direct, method in which the heat is drawn off by moving air in direct contact with the engine. Several fundamental principles of cooling are embodied in this type of engine cooling. The rate of the cooling is dependent upon the area exposed to the cooling medium, the heat conductivity of the metal used, the volume of the metal or its size in cross section, the amount of air flowing over the heated surfaces, and the difference in temperature between the exposed metal surfaces and the cooling air. Some heat, of course, must be retained for efficient operation. This is done by use of thermostatic controls and mechanical linkage, which open and close shutters to control the volume of cooling air. You will find that air-cooled engines generally operate at a higher temperature than liquid-cooled engines, whose operating temperature is largely limited by the boiling point of the coolant used. Consequently, greater clearances must be provided between the moving parts of air-cooled engines to allow for the increased expansion. Also, lubricating oil of a higher viscosity is generally required.

In air-cooled engines, the cylinders are mounted independently to the crankcase so that an adequate volume of air can circulate directly around each cylinder, absorbing heat when passing the cylinders and maintaining cylinder head temperatures within allowable limits for satisfactory operation. In all cases, the cooling action is based on the simple principle that

the surrounding air is cooler than the “heat engine.” The main components of an air-cooled system are the fan, shroud, baffles, and fins. A typical air-cooled engine is shown in figure 5-1.

Fan and Shroud

All stationary air-cooled engines must have fans or blowers of some type to circulate a large volume of cooling air over and around the cylinders. The fan for the air-cooled engine shown in figure 5-1 is built into the flywheel. Notice that the shrouding or cowling, when assembled, will form a compartment around the engine so that the cooling air is properly directed for effective cooling. Air-cooled engines, such as those used on motorcycles, do not require the use of fans or shrouds because their movement through the air results in sufficient airflow over the engine for adequate cooling.

Baffles and Fins

In addition to the fan and shroud, some engines use baffles or deflectors to direct the cooling air from the fan to those parts of the engine not in the direct path of airflow. Baffles are usually made of light metal and are semicircular with one edge in the air stream so that the air can be directed to the back of the cylinders. Most air-cooled engines use fins. These are thin, raised projections on the cylinder barrel and head. (See figure 5-1.) The fins provide more cooling area or surface and aid in directing airflow. Heat resulting from

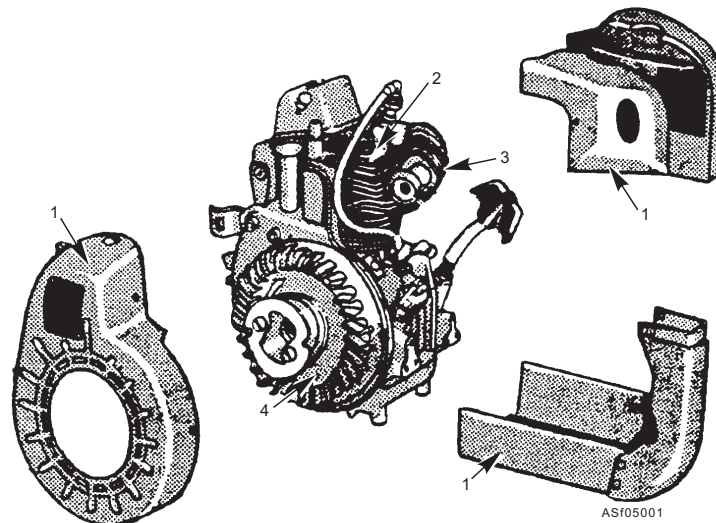

- 1. Sheet metal shrouding
- 2. Finned cylinder head
- 3. Finned cylinder barrel
- 4. Flywheel fan

Figure 5-1.—Air-cooled engine.

combustion passes by conduction from the cylinder walls and cylinder head to the fins, and is carried away by the passing air.

Maintaining the Air-Cooled System

You may feel that because the air-cooling system is so simple it requires no maintenance. Too many mechanics feel this way; many air-cooled engine failures occur as a result. Maintenance of an air-cooling system consists primarily of keeping cooling components clean. Clean components permit rapid transfer of heat and ensure that nothing prevents the continuous flow and circulation of air. To accomplish this, keep fans, shrouds, baffles, and fins free of dirt, bugs, grease, and other foreign matter. The engine may look clean from the outside, but what is under the shroud? Accumulation of dirt and debris here can cause real problems.

Keep the area between the engine and shroud clean. Paint can cause a problem. Sometimes a mechanic will reduce the efficiency of the cooling system by careless use of paint. The engine may look good, but most paints act as an insulator and hold in heat. In addition to keeping the cooling components clean, you should inspect them each time the engine is serviced. Replace or repair any broken or bent parts. Check the fins for cracks or breaks. When cracks extend into the combustion chamber area, the cylinder barrel must be replaced.

LIQUID-COOLING SYSTEMS

Nearly all multicylinder engines used in automotive, construction, and material-handling equipment use a liquid-cooling system. Any liquid used in this type of system is called a “coolant.”

In most liquid-cooled engines, excess heat is removed by the circulation of the coolant through hollow passages surrounding the hottest parts of the engine. Heat flows first into the coolant while the coolant is being pumped through the passages of the cylinder block and up into the cylinder head. The coolant then moves on through similar passages in the head, picks up more heat as it circulates, and finally leaves the engine through an outlet at the top.

After leaving the engine, the coolant passes through an upper hose connection and carries the heat into a radiator. As the coolant flows down through the radiator, a stream of air forced through the radiator removes the heat. In stationary engines, the fan provides all of the airflow. For engines installed in

vehicles, airflow is provided both by the fan and the forward motion of the vehicle.

From the bottom of the radiator, the coolant flows through a lower hose connection to the pump where it is again forced into the cylinder block and repeats the cooling cycle, thus removing more heat from the engine and carrying the heat into the radiator.

The amount of engine heat that must be removed by the cooling system is much greater than is generally realized. To handle this heat load, it may be necessary for the cooling system in some engines to circulate 4,000 to 10,000 gallons of coolant per hour. The water passages, the size of the pump and radiator, and other details are so designed as to maintain the working parts of the engine at the most efficient temperature within the limitations imposed by the coolant. Figure 5-2 shows a typical liquid-cooling system and most of its components.

Radiator

The radiator is probably the key unit in a liquid-cooled system. It is a device for holding a considerable volume of coolant in close contact with a large volume of air so that heat may be transferred from the coolant to the air.

The usual radiator assembly consists of a radiator core with a top tank and a bottom tank. The top, or inlet tank, has an outside pipe called the “radiator inlet,” and it usually has a coolant baffle inside and above or at the inlet opening. The radiator filler neck is generally attached to the upper part of the top tank and has an outlet to the overflow pipe. The bottom tank also has a pipe that is the radiator outlet. Many radiators for vehicles equipped with automatic transmissions have an inner core located in the bottom tank through which transmission oil is circulated to assist cooling of the transmission.

Practically all cooling systems have tubular radiator cores (fig. 5-3), which consist of a large number of vertical tubes and many horizontal air fins around the tubes. Water passages in the tubes are usually quite narrow, and the tube itself is made of thin metal.

Through the water tubes, the flow of coolant is divided into many small streams, which cause a small amount of cooling liquid to be exposed to a comparatively large cooling surface. This results in rapid flow of heat from the coolant to the tubes and air

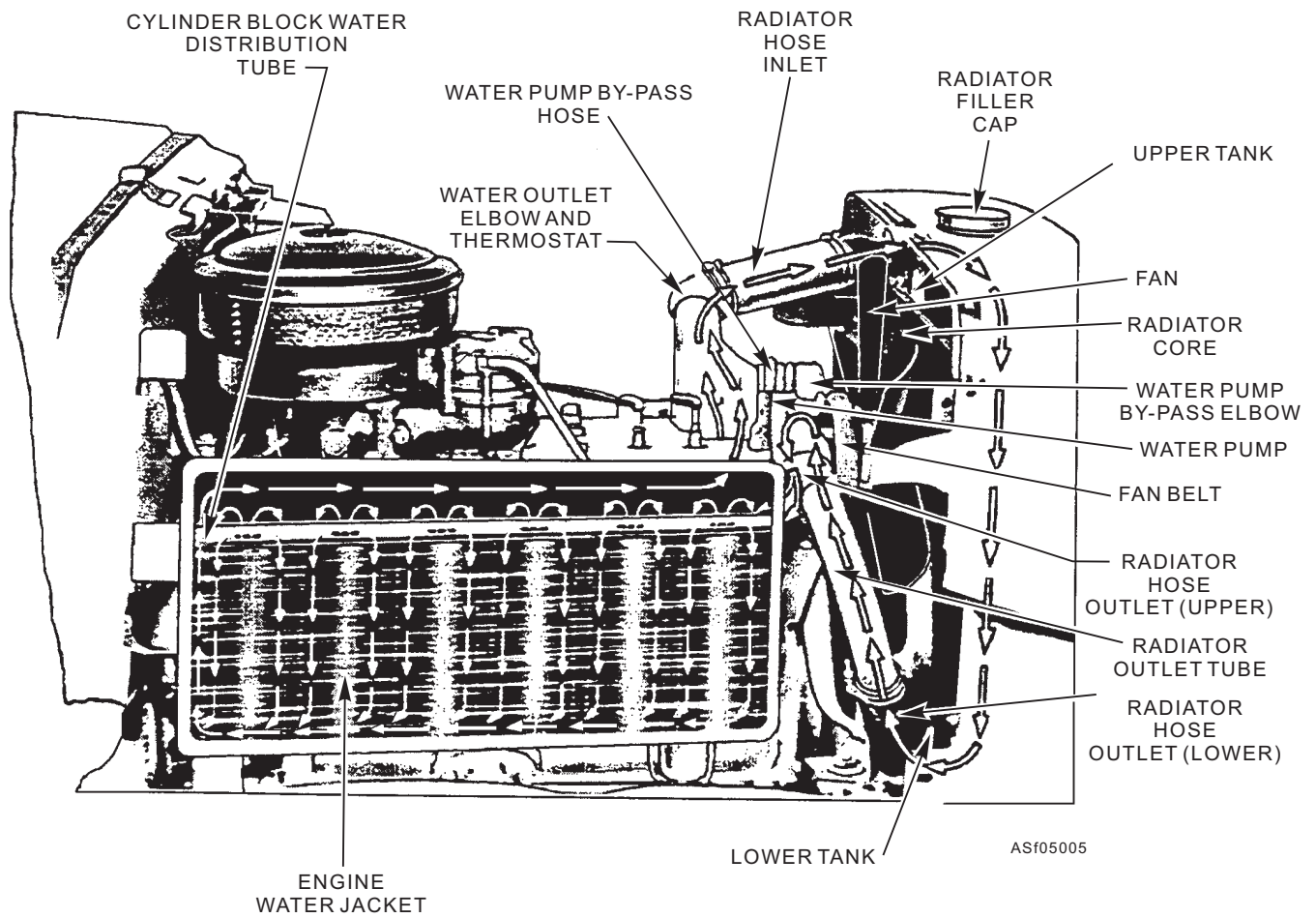

Figure 5-2.—Liquid-cooling system.

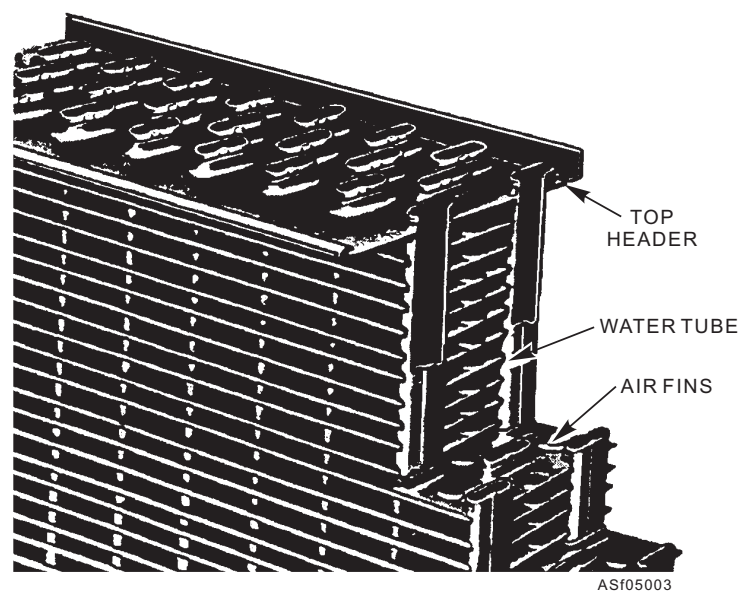

Figure 5-3.—Tubular radiator core construction.

fans. Heat is carried away from the tubes and fins by the movement of the air through the core.

Connections must be provided to carry the water from the engine water jacket to the radiator, and from the radiator back to the engine. Vibration and movement between the radiator and the engine could cause breakage of the metal pipe. For this reason, flexible hose is used for radiator connections. Sometimes, pieces of pipe are placed in sections of long hoses. This reduces the danger of hose collapse and makes a stronger connection.

Radiator Pressure Cap

The radiator pressure cap (fig. 5-4) is used on nearly all modern engines. The pressure cap closes off the overflow pipe and prevents loss of coolant during normal operation. It also allows a certain amount of pressure to develop within the cooling system. The pressure raises the boiling point of the coolant approximately 3 degrees for each psi (pound per square inch) and permits the engine to operate at higher temperatures without loss of coolant from boiling.

The pressure cap contains two spring-loaded valves. The larger valve is called the pressure valve and the smaller one is called the vacuum valve. A shoulder in the radiator filler neck provides a seat for the bottom of the cap assembly, and a gasket on this

seat prevents leakage between the cap and the filler neck.

The pressure valve acts as a safety valve to relieve extra pressure within the system. The cooling system may be designed to operate at various pressures, 4 to 17 psi, depending on the manufacturer's specifications. The pressure valve in the cap is preset by the manufacturer. When replacing a pressure cap, make sure you use a cap with the proper pressure setting, which is usually marked on the top surface of the cap.

The vacuum valve opens only when the pressure within the cooling system drops below the outside air pressure as the engine cools down. This automatic action of the vacuum valve prevents collapse of the hose and the radiator.

WARNING

Always remove the radiator cap slowly and carefully. Removing the cap from a hot, pressurized radiator can cause serious burns from escaping steam and coolant.

Water Pump

The water pump is the heart of the cooling system. Most engines use a centrifugal water pump, like the

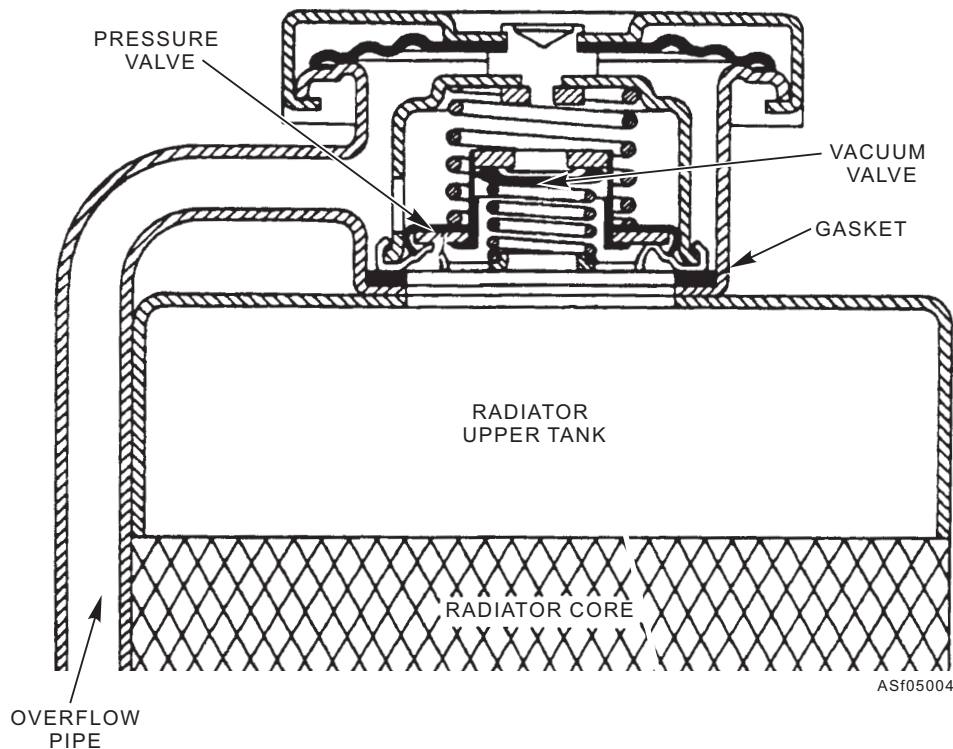

Figure 5-4.—Radiator pressure cap.

one shown in figure 5-5, which provides a large volume capacity and is nonpositive in displacement. This type of pump has an impeller with blades that force the coolant outward as the impeller rotates. The shaft on which the impeller is mounted is usually driven by a fan belt and revolves in a bushing or in ball bearings inside the housing, as shown in the illustration. Also shown in the illustration is the nonadjustable seal assembly, which prevents leakage around the externally driven water pump shaft. For different cooling systems, pumps vary considerably in construction of seals, bearings, mounting, and drive.

Fan and Shroud

The engine fan is usually mounted on the end of the water pump shaft and is driven by the same belt that drives the pump. The fan pulls a large volume of air through the radiator core, which cools the hot water circulating through the radiator. In addition to removing heat from the water in the radiator, the flow of air created by the fan causes some direct cooling of the engine itself. Some engines are equipped with a

shroud that improves fan efficiency by assuring that all the air handled by the fan passes through the radiator.

Fan blades are spaced at intervals around the fan hub to aid in controlling vibration and noise. They are often curled at the tip to increase their ability to move air. Except for differences in location around the hub, most blades have the same pitch and angularity.

Bent fan blades are very common and result in noise, vibration, and excess wear on the water pump shaft. You should make it a practice to visually inspect the fan blades, pulleys, pump shaft endplay, and drive belts at every preventive maintenance inspection.

At 300 rpm, an 18-inch fan will consume over 2 hp. This power drain increases rapidly with an increase in engine speed. Since the fan is required primarily at low engine speeds, couplings have been devised that disconnect the fan above certain speeds.

The fan drive clutch is a fluid coupling that contains silicone oil. Fan speed is controlled by the torque-carrying capacity of the oil. The more silicone oil in the coupling, the greater the fan speed; the less silicone oil, the slower the fan speed.

Two types of fan drive clutch controls are in use today. One type uses a bimetallic strip and control piston in the front of the fluid coupling. The bimetallic strip bows outward with an increase in surrounding temperature and allows the piston to move outward. The piston opens a valve that regulates the flow of silicone oil into the coupling from a reserve chamber. When the valve is closed, the oil is returned to the reserve chamber through a bleed hole.

The bimetallic, spring-type, fan drive clutch uses a spring connected to an opening plate. This produces an action much the same as the bimetallic strip type of control. Both types of controls cause the fan speed to increase with a rise in temperature and to decrease as the temperature goes down.

Water Jacket

The water passages in the cylinder block and cylinder head form the engine water jacket. (See figure 5-2.) In the cylinder block, the water jacket completely surrounds all cylinders along their full length. Within the jacket, narrow passages are provided between the cylinders for coolant circulation around them. In addition, water passages are provided around the valve seats and other hot parts of the cylinder block. In the cylinder head, the water jacket covers the combustion chambers at the top of the cylinders and contains

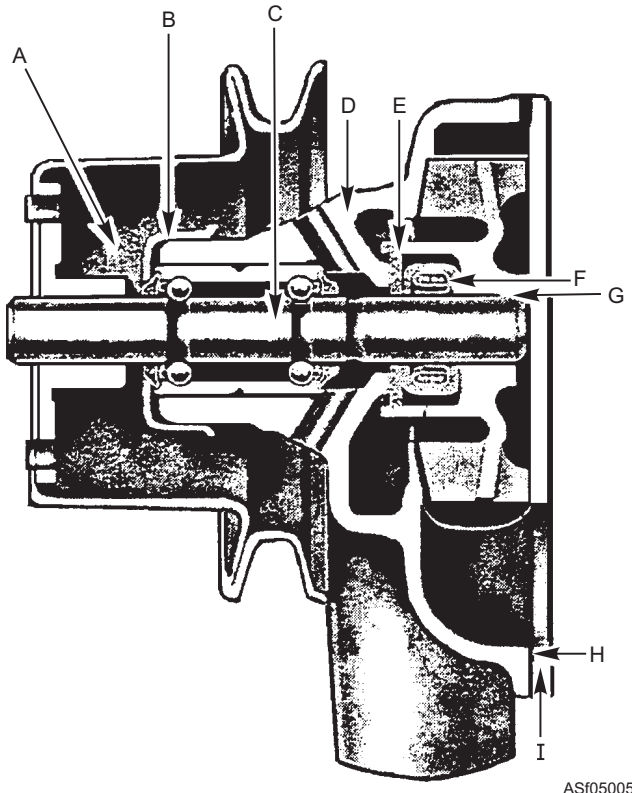

- | | |
|-------------------------------|------------------|
| A. Pulley and hub assembly | F. Seal assembly |
| B. Bearing retainer | G. Impeller |
| C. Shaft and bearing assembly | H. Plate gasket |
| D. Body | I. Plate |
| E. Seal washer | |

Figure 5-5.—Water pump.

passages around the valve seats when the valves are located in the head.

The passages of the water jacket are designed to control circulation of coolant and provide proper cooling throughout the engine. The pump forces coolant directly from the lower radiator tank connection into the forward portion of the cylinder block. This type of circulation would, obviously, cool the No. 1 cylinder first, causing the rear cylinders to accept coolant progressively heated by the cylinders ahead. To prevent this condition, some blocks are equipped with a water distribution tube (fig. 5-2) that extends from front to rear of the block, with holes adjacent to (and directed at) the hottest parts of each cylinder. Some engines are equipped with ferrule type water directors, which direct a jet of water toward the exhaust valve seats.

Thermostats

Automatic control of the engine's temperature is necessary for efficient engine performance and economical operation. If the engine is allowed to operate at a low temperature, sludge buildup and excessive fuel consumption will occur. On the other hand, overheating the engine or operating it above normal temperature will result in burnt valves and faulty lubrication. The latter usually causes early engine failure.

Since all engine parts are in a contracted state when cold, the engine temperature should be brought to normal as quickly as possible. The water pump starts coolant circulating the moment the engine is started, which is undesirable for cold weather

operation. To restrict coolant circulation, a thermostatically controlled valve, or thermostat, is installed in the cylinder head water outlet. This valve allows coolant to circulate freely only within the block until the desired temperature is reached. This shortens the warm up period. A bypass is used to direct the water from the block back to the pump when the passage to the radiator is blocked by the closed thermostat (fig. 5-6).

Thermostats are manufactured in several designs, the most common being the bellows and the pellet.

BELLOWS THERMOSTAT.—The BELLOWS thermostat (fig. 5-7) consists of a round bellows that contains a small amount of a highly volatile liquid (such as ether). The liquid creates a pressure when heated. This pressure opens the valve as the engine warms up and allows the coolant to circulate. Should the bellows become punctured or ruptured, the thermostat will remain in the open position.

PELLET THERMOSTAT.—The PELLET thermostat (fig. 5-8) uses the piston and spring pressure principle. A small mass of powder-like crystals is enclosed within a small sealed receptacle (pellet) from which a small piston rod extends to the valve. The crystals expand under heat and push the piston sufficiently to overcome spring tension. This opens the valve. Spring tension closes the thermostat when the crystals contract. Operative failure of this kind of thermostat is caused by impregnation of the pellet with coolant, causing it to remain in the open position.

OPERATION OF THE THERMOSTAT.—Although a thermostat is designed to open at a specific

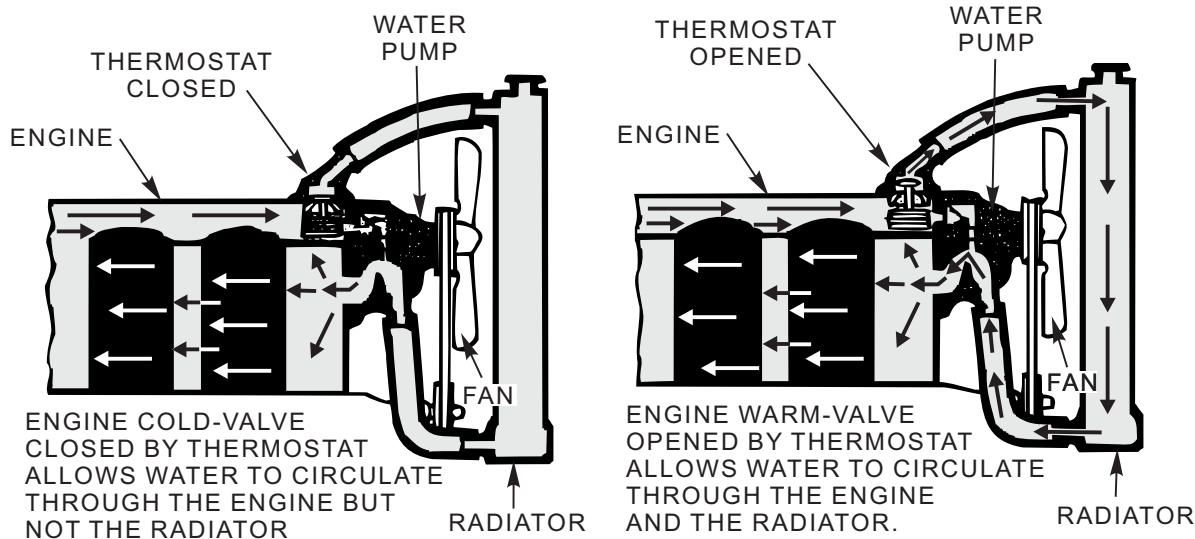

Figure 5-6.—A thermostat in operation.

Asf05006

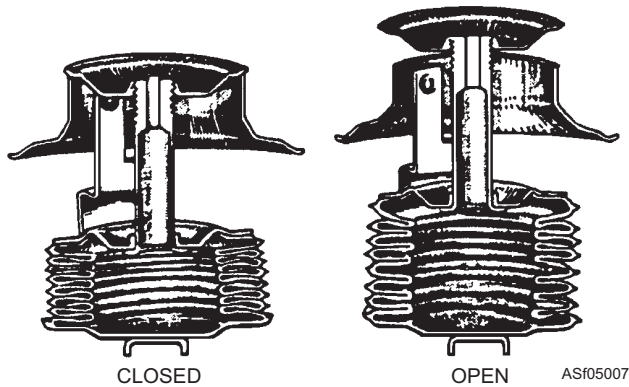

Figure 5-7.—Bellows thermostat.

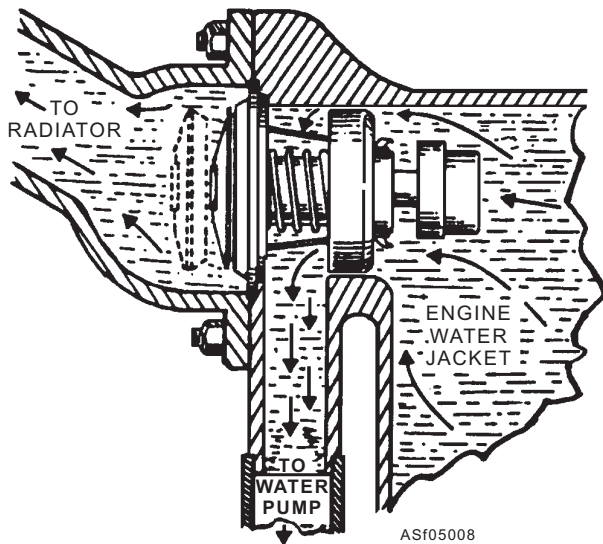

Figure 5-8.—Pellet thermostat.

temperature, most thermostats vary a few degrees in the temperature at which they begin to open. In addition, they may require a temperature from 20° to 25°F higher before they are fully open. For instance, a thermostat designed to open at 150°F might begin to open at any temperature between 146° and 154°F. This same thermostat should be fully open at 170° to 175°F.

Some stationary engines and large equipment are equipped with shutters that supplement the action of the thermostat in providing a faster warm up and in maintaining proper operating temperatures. When the engine coolant is below a predetermined temperature (185° to 195°F), the shutters, located in front of the radiator, remain closed and restrict the flow of air through the radiator. Then, as the coolant reaches proper temperature, the shutters start to open, allowing air to circulate through the radiator. The temperature of the coolant, when it reaches the predetermined temperature, causes the valve to expand, extending a rod that (through linkage) forces the shutters open.

Overflow Tank

An overflow tank, sometimes referred to as a surge tank or expansion tank, serves as a receptacle for coolant forced out of the radiator overflow pipe and provides for its return to the system. As the engine cools, the balancing of pressures causes the coolant to siphon back into the radiator. This requires a plain cap on the radiator and a pressure cap on the overflow tank.

Cooling systems that use an overflow tank are known as closed cooling systems. Coolant is usually added to this system through the overflow tank, which is marked for proper coolant level.

WARNING

Never remove the plain cap located on the radiator unless you are positive the system is cold. If there is any pressure in the radiator, it will spray you with hot steam and coolant. Use extreme caution whenever you work around a closed cooling system.

Temperature Gauge

The engine temperature gauge is made up of two principal parts: the gauge unit mounted on the instrument panel and the engine thermal unit. When operated on the principle of the Bourdon tube, the temperature gauge is actuated by pressure from a bulb, which is screwed into the water jacket of the engine. The heat of the water vaporizes the liquid in the bulb, and the vapors flow through a capillary, which is a very small tube connecting the bulb to the gauge. The greater the heat, the more vapor is given off, the greater the pressure, and the higher the temperature indicated on the gauge.

When installing the temperature gauge or repairing other parts of the engine, be careful not to kink the tube connecting the gauge and sending unit. Although it looks like an ordinary wire, this tube contains the fluid that operates the gauge unit on the instrument panel. A damaged temperature gauge must be replaced as a whole unit and cannot be repaired in the shop.

Some vehicles are equipped with an electric temperature gauge. The higher the temperature, the greater the current passing through the coils to the indicating unit, which, in turn, moves the needle to register the engine temperature.

Coolants and Antifreeze

Since water is easily obtained, cheap, and has the ability to transfer heat readily, it has served as a basic coolant for many years. Some properties of water, such as its boiling point, freezing point, and natural corrosive action on metals, limit its usefulness as a coolant. To counteract this, antifreeze is used. The most commonly used type of antifreeze is ethylene glycol. It is chemically compounded of a mixture of ethylene and glycerin derivatives and is manufactured under many trade names. A normal mixture of antifreeze is usually 50-percent ethylene glycol and 50-percent water; however, check with the maintenance instruction manual (MIM) for each specific type of equipment for the proper mixture. Maximum freezing protection is achieved by mixing 60-percent ethylene glycol with 40-percent water. This will protect the cooling system to about -62°F. Ethylene glycol has a very high boiling point, does not evaporate easily, and is noncorrosive and practically nonflammable.

SERVICING THE LIQUID-COOLING SYSTEM

Because the effects or damages that result from an improperly serviced cooling system usually occur gradually, this system tends to be neglected. However, the requirements of modern liquid-cooled engines and the severe conditions under which they often operate make it necessary that the cooling system be maintained at maximum efficiency. This is particularly true in the case of V-8 engines, especially the larger ones, because of the increase in the heat generated and the slight margin of safety provided by the design of the cooling system. In fact, only a slight loss in circulation or cooling efficiency can be critical. When the vehicle is loaded with power equipment, it places an additional load on the engine at idle or in slow traffic on hot days. In view of this, it is essential that proper inspection and servicing be accomplished to keep the cooling system in good condition. Proper servicing includes cleaning and flushing, rust prevention, use of antifreeze, and cooling system testing.

Cleaning and Flushing

Accumulations of rust and scale in the cooling system eventually restrict the circulation of coolant, and the engine is likely to overheat. Correcting this

condition requires that the cooling system be drained and flushed.

NOTE: Old coolant must be contained and treated as hazardous material. For detailed instructions, see your equipment manuals and shop instructions.

A cleaning compound can be used to remove rust and scale from the system. In using the compound, you must be careful to follow the manufacturer's instructions. Following this, the system should be neutralized, since cleaners contain strong acids that, if not completely removed, attack parts of the cooling system.

WARNING

Engine cooling system cleaning compound is poisonous and may be fatal if swallowed. Avoid contact with your eyes or prolonged contact with your skin. Avoid spilling compound on the painted surface of the vehicle.

Some manufacturers recommend reverse-flushing; for example, forcing water and air through the system in the direction opposite to normal circulation. This tends to loosen the scale and flush it, along with any sediment, out of the system.

Some AS shops are equipped with reverse-flushing equipment. It usually consists of a flushing gun device similar to that shown in figure 5-9. In the figure, a gun is being used on the radiator that has been filled with water and the cap installed. Notice that the lower radiator hose has been disconnected from the water pump and that the gun is used to force water and air through this hose and into the radiator. The air pressure is applied intermittently to loosen scale and sediment better. Excessive air pressure should be avoided to prevent damage to the radiator. Starting and stopping the flow of water produces a fluctuation of pressure and tends to loosen all foreign matter clinging to the water passages in the radiator core. As shown in figure 5-9, the upper hose has been disconnected from the engine so that the water can be directed to suitable disposal containers.

Reverse-flushing equipment can also be used, as shown in figure 5-10, to reverse-flush the engine block and head. First, remove the thermostat and disconnect the upper radiator hose between the water outlet and the radiator. Then disconnect the lower radiator hose at the water pump and insert the flushing equipment in the upper radiator hose. Reverse-flush the system by

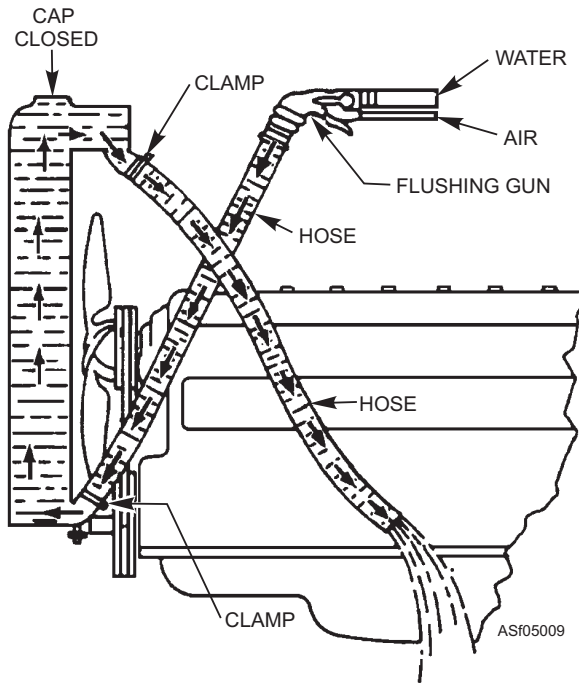

Figure 5-9.—Reverse flushing of radiator.

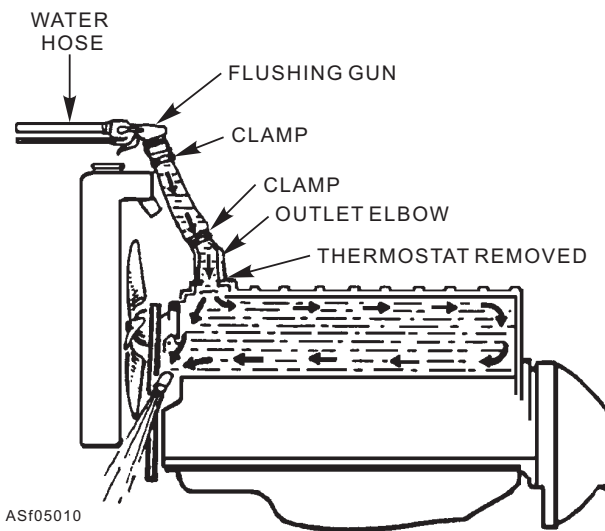

Figure 5-10.—Reverse flushing of water jackets.

sending water and air through the water jackets and coolant passages. After flushing, the thermostat and hoses can be replaced and the system refilled. Where reverse-flushing equipment is unavailable, you can still reverse-flush the system with an ordinary garden hose. This is often effective following the use of a cleaner and neutralizer.

Preventing Rust

Rust is the result of iron and oxygen present in the system, and it can only be controlled by maintaining full-strength corrosion protection at all times. An

indication of the presence of rust, scale, or grease can be obtained by running your finger around the inside of the filler neck of the radiator. The grease and rust deposits collected on your finger will show if this servicing is required.

The use of inhibitors or rust preventives reduces the corrosion of metals and prevents the formation of scale. Inhibitors are not cleaners and do not remove rust or scale already formed. Treating the cooling system with an inhibitor consists of adding it to the coolant. The inhibitor should be renewed periodically, especially if the system has been recently cleaned or flushed. Permanent type antifreeze contains an inhibitor so that during cold weather a separate inhibitor need not be used. Inhibitor in the required amount should always be used in the cooling system after antifreeze has been drained. The required amount of inhibitor is indicated on the container and depends on the cooling system capacity.

Using Antifreeze

Permanent antifreeze of the ethylene glycol type is used to protect the cooling system during cold weather. Before installing antifreeze in the system, you should check for leaks and, if necessary, clean and flush the cooling system. Also, you should check the thermostat, pressure cap, and all hoses. If the system has a radiator overflow tank, you should rinse it by filling with water and then completely draining.

After filling the system to about one-third capacity with water, you are ready to add the antifreeze. But just how much antifreeze should you use? This will depend on the capacity of the cooling system and the lowest expected temperature. The system should be protected to at least 10° below the lowest expected temperature. Table 5-1 indicates the number of pints of permanent antifreeze needed per gallon of cooling system capacity to afford protection to the various temperatures listed. Thus, if your cooling system (with heater) had a capacity of 22 quarts (5 1/2 gallons), you would need to use approximately 18 pints (2 1/4 gallons) of antifreeze to afford adequate protection to -10°F or 19 1/4 pints (slightly over 2 3/8 gallons) to protect to -20°F. In this connection, you should note that the maximum protection available is obtained by using about 4 3/4 pints of ethylene glycol for each gallon of the cooling system capacity. This means that the solution would then contain about 60 percent ethylene glycol by volume to protect to -60°F. When you attempt to use a greater proportion of antifreeze

Table 5-1.—Permanent Antifreeze Needed Per Gallon of Cooling System Capacity

Protection to:	Pints
+10°F	2
0°F	2 3/4
-10°F	3 1/4
-20°F	3 1/2
-30°F	4
-40°F	4 1/4
-50°F	4 1/2
-60°F	4 3/4

than this, little, if any, advantage results. A straight ethylene glycol (100 percent) affords less protection than one containing 60-percent ethylene glycol and 40-percent water. In other words, up to a point, the water acts as “antifreeze” for the ethylene glycol.

After adding the required amount of antifreeze, you should fill the system with clean water, leaving room for the expansion, and operate the engine to mix the solution. Then add water, if necessary, to bring the coolant level to that prescribed for the vehicle. You should then stop the engine and check the solution with an antifreeze hydrometer to make sure the system is protected to the desired temperature.

Most modern high-compression engines, especially those equipped with air-conditioning, require the use of antifreeze year round for efficient performance of the cooling system and engine.

Cooling System Testing

It is often necessary to check the cooling system for leaks that are hard to find. Leaks in the cooling system should not be permitted to continue, since boiling and overheating will tend to occur, resulting in breaking down the oil film and possibly damaging the engine. Air will be drawn into the system if leaks are present between the radiator and water pump, causing foaming and loss of coolant, as well as accelerating rusting and corrosion. To check for such leaks, connect a hose to the overflow pipe and place the other end of the hose in a pail of water. If the system is full and the warmed-up engine is running, any air drawn into the

system will be indicated by bubbling in the pail of water. Air leaks are usually corrected by tightening the hose clamps of the hose connecting the radiator to the water pump or replacing the hose, if necessary. The trouble may also be caused by a leaking water pump or exhaust gas leakage.

Exhaust gas leaking into the cooling system, usually as a result of a leaking cylinder head gasket, will result in damage to the system due to the action of acids formed in the system. To check for exhaust gas leakage, remove the fan belt, upper radiator hose, and thermostat. Then drain out some coolant until its level is just above the top of the cylinder head. If the engine is accelerated quickly several times, exhaust gas leakage will generally reveal itself by bubbling at the thermostat outlet or by a rise in coolant level beyond that caused by normal coolant expansion.

A radiator pressure tester can also be used to check for leaks. The device is installed on the radiator filler neck in place of the pressure cap. Then air pressure is applied and the gauge observed for a pressure drop, which would indicate a leak. Pressure should not exceed that recommended by the manufacturer. On a system with a 14-pound pressure cap, for example, do not apply more than 15 psi. If the leak cannot be located externally, inspect the engine oil to determine whether coolant is leaking into the crankcase due to a cracked cylinder block or leaking head gasket.

To check for compression or combustion leakage, run the engine until it reaches normal operating temperature. Then pressurize the system with the engine running. Fluctuating pressure as the engine is accelerated indicates a combustion leak. In the case of a V-8 engine, you can determine which bank is at fault by disconnecting the spark plug leads from one bank and running the engine on the other. The combustion leak is in the bank furnishing the power when the pressure fluctuates. To determine which cylinder is leaking, disconnect the spark plug wires one at a time and observe the tester dial. When the plug wire is removed from the leaking cylinder, the indicator will stop fluctuating. If more than one cylinder leaks, removing the plug lead from an offending cylinder will cause the fluctuation to become less frequent. If tightening the cylinder head to specifications does not stop the leak, replace the head gasket and recheck for leakage.

You can use the radiator pressure tester to test the radiator pressure cap by using an adapter provided for this purpose. The adapter is screwed onto the lower end of the tester, and the pressure cap is installed on the

other end of the adapter. The cap rubber gasket should be wet to ensure an airtight seal. Then, by applying air pressure as specified for the particular cap, you can determine if it is capable of retaining the pressure as it should.

Another tester used with cooling systems is the antifreeze hydrometer, which is used to determine if adequate protection against freezing is afforded by the antifreeze solution in use. This hydrometer shows the specific gravity of the solution, thus giving you an indication of what percentage of the solution is water and what percentage is ethylene glycol. Then, by referring to a chart that corrects for the coolant temperature, you can determine if additional antifreeze should be added to the system. The accuracy of the tester can be checked by taking a test reading of a mixture containing one part antifreeze and two parts water, which should test to 0°F. The tester manufacturer's instructions should be followed for proper use and care of the hydrometer. Accurate readings are not possible if the float and the inside of the glass barrel are dirty.

Before reading the tester, you should fill and empty the hydrometer barrel several times to equalize the temperature of all parts. First, read the first number or letter on the float above the surface of the liquid, and then note the solution temperature from the first division or number above the top of the indicating column of the thermometer. These two readings should be made at the same time and as soon as possible after drawing the solution into the hydrometer. The freezing protection of the solution is determined by matching float and thermometer readings of the chart on the hydrometer. Tests will be inaccurate if made immediately after adding water or antifreeze. Most antifreeze hydrometers give the most accurate readings at solution temperatures around 110°F. Even with hydrometers designed to read at solution temperatures below 0°F, tests should always be made with the temperature of coolant above 60°F, if possible, because the solution is more viscous when cold. This condition prevents the float from finding its true level quickly and may result in a false float reading.

REPAIRING COOLING SYSTEM COMPONENTS

The individual components of the cooling system that require servicing and repair include the water jacket in the cylinder block and head, radiator, hoses, water pump, fan and fan belt, and thermostat.

Water Jacket

Some maintenance aspects in connection with the water jacket have already been discussed, including cleaning and preventing rust and corrosion. But where water jackets are badly clogged and do not respond to regular or reverse flushing, the engine can be directly flushed through the core holes, also referred to as freeze plugs. To do this, first remove some of the core hole plugs from the cylinder block and head. Then, with a suitable length of small copper tubing attached to the flushing gun nozzle, flush the water jacket through the openings. New plugs should then be installed. Any plugs that show signs of leaking or rusting must be replaced. All drain plugs should be kept free of rust and scale. Gaskets must be in good condition to prevent both internal and external leaks. If there are external leaks around gaskets, there may also be internal leaks into the engine. Proper tightening of the head bolts or cap screws with a torque wrench is essential for preventing leaks around the head gasket. If this fails to correct the difficulty, the gasket must be replaced.

Radiator

The radiator should be checked for leaks, particularly where the tanks are soldered to the core, since vibration and pulsation from pressure can cause fatigue of soldered joints or seams. Neglect of small leaks may result in excessive leakage, rust clogging, overheating difficulties, or complete radiator failure. Thus, it is extremely important to keep the radiator mounting properly adjusted and tight at all times and to detect and correct even the smallest leaks. A leak usually reveals its presence by scale marks or watermarks below the leak on the outside of the core. Contrary to popular belief, permanent antifreeze does not leak through spaces where water won't pass. What actually occurs is that the antifreeze leak is more noticeable, since it does not evaporate as quickly as water. Often, small leaks can be effectively mended by using one of several commercially available radiator sealers (powders or liquid-solder compounds), which harden upon contact with the air, thus sealing off any small openings. Leaks can also be repaired by ordinary soldering. When large leaks or considerable damage is present, removal of the radiator for extensive repair or replacement is usually required.

Bent fins should be straightened and the radiator core checked for any obstructions that could restrict the airflow. Radiator air passages can be cleaned by

blowing them out with an air hose in the direction opposite to the ordinary flow of air. Water can also be used to soften obstructions before applying the air blast. In any event, the cleaning gets rid of dirt, bugs, leaves, straw, and other debris that otherwise would clog the radiator and reduce its cooling efficiency. Sometimes screens are used in front of radiator cores to prevent this type of clogging.

The radiator can be checked for internal clogging by removing the hose connections and draining the radiator. Then, introduce a stream of water into the top from a garden hose and observe the flow coming out at the bottom. If the flow is sluggish, the radiator is partially clogged. Another way to check for this condition is to feel the radiator with your hand after the engine has been operated for some time. The radiator should be warm at the bottom and hot at the top, with the temperature increasing uniformly from bottom to top. Any clogged sections will feel cool.

WARNING

To avoid injury from the fan, do not make this test while the engine is running.

Where use of cleaning compounds and reverse flushing fails to relieve a clogged core, the radiator must be removed for mechanical cleaning. This requires the removal of upper and lower tanks and removing the accumulated rust and scale from the water passages of the core.

The radiator pressure cap should also be checked for condition and proper operation. If it is dirty, the cap can be cleaned with soap and water and then rinsed. The seating surfaces of the vacuum and pressure valves should be smooth and undamaged. The valves should operate freely when pressed against their spring pressures and should seal properly when closed. By using the pressure tester, you can quickly check the cap for proper operation.

Hoses

All hoses and tubing should be checked frequently for leakage and general condition. You can also correct the leakage by tightening or replacing the hose clamps. Deteriorated hoses should be replaced to preclude future troubles. For example, hoses sometimes rot on the inside, allowing tiny fragments to flow through the system and become lodged in the radiator, tending to clog it and cause overheating. Any restriction in the

radiator slows circulation so that the suction of the water pump creates a low-pressure pocket, which permits the water to convert immediately to steam and perhaps cause the engine coolant to boil over. Therefore, all old, cracked, or spongy hoses should be replaced as soon as the condition is discovered. The lower radiator hose is particular suspect because it is on the vacuum side of the pump. When this hose becomes soft with age, it tends to collapse, with the result just described. You can check such hoses as well as others by squeezing them; if they are “mushy,” they should be replaced. However, where spiral spring stiffeners are used to control the tendency to collapse, such a test will not work and the hose will need to be removed for inspection.

Water Pump

Normally, the water pump requires little in the way of maintenance in day-to-day operation. Nearly all water pumps use sealed bearings, so that even lubrication service has been eliminated. However, where provided, the air vent at the top of the housing and the drain hole at the bottom should be checked to make sure they are not plugged with grease or dirt. Pumping failures are most often caused by a broken or loose drive belt, which requires that the belt be replaced or adjusted. Leaks, which are also quite common, may sometimes be corrected by replacing the pump gasket. However, after long service, the pump may develop a leak around the shaft or become noisy due to worn bearings or other defects. It will then require replacement or rebuilding. Pumping capacity can be reduced as a result of edge wear of impeller blades and wear of the pump housing caused by abrasive action of sand or rust in the system. Sometimes a pump may cease to circulate coolant because of eroded impellers or vanes or a buildup of rust or mineral deposits on the impellers or vanes. The pump operation can be checked with the engine running by squeezing the upper radiator hose to ascertain the presence of a pressure surge.

Whether a defective pump is replaced or rebuilt depends on parts supply and cost. Repair kits are sometimes available for rebuilding water pumps. In most cases, however, it is more economical to simply replace the pump. In fact, there are some pumps for which repair kits are not made. In any event, the removal and installation procedures, as well as the rebuilding procedure (if applicable), will vary on different pumps. Therefore, the applicable shop manual must be consulted for the step-by-step

procedures and any specifications, clearances, or tolerances pertinent to the job.

When you replace a pump, install a new gasket. Make sure the mating surfaces are clean and smooth. The application of sealer to both sides of the gasket is often recommended. Then, after refilling the system, the pump should be checked for leaks, noise, and proper operation.

Fan and Belt

A bent or distorted fan or one with a loose blade should be replaced. Where the fan is merely loose on its mounting, you can tighten it. Loose fan belts can be adjusted for proper tension, usually by shifting the generator on its mounting. A common method for measuring belt tension is to press down on the belt at a point midway between the generator and fan pulley; then measure the amount of deflection. The amount of deflection will vary and should be set to the manufacturer's specification. The amount of deflection will depend on whether the belt is new or used and the distance between the pulleys. The normal adjustment of the belt is measured between the two pulleys furthest apart. The belt should have no more than one-half deflection between the two pulleys.

A belt adjustment that is just tight enough to prevent slipping may be considered correct. A belt that is too tight can cause the generator or alternator bearing to wear rapidly. A belt that is too loose may squeak when the engine is accelerating. When a belt is misaligned, a squeak may occur at idle speed. Correction can be made by using spacers on the accessories or by filing brackets. However, if the squeak is caused by a non-uniform groove or eccentric pulley, the pulley should be replaced.

Replacement of a defective belt is usually made by loosening the generator mounting bolts and the generator adjusting arm and moving the generator closer to the engine. The belt can then be removed over the fan and a new one installed and adjusted.

Thermostat

There are no repairs or adjustments to be made on the ordinary thermostat. The unit must be replaced if it fails to operate properly. The temperature at which the thermostat opens is very important and should be tested whenever the cooling system operating temperature indicates the need. To remove the thermostat, drain the coolant until its level is below the thermostat, remove the hose connecting the thermostat

outlet to the radiator if necessary, and remove the outlet retaining cap screws. The thermostat can then be removed and checked for condition and operation. If it is excessively rusted or bent, or if the valve is not tightly closed, the thermostat must be discarded.

If the thermostat appears to be in good condition, its operation can be tested, as shown in figure 5-11. The thermostat is suspended in a container of water together with a high-temperature thermometer. Then, by heating the container on a stove or hot plate, the temperature at which the thermostat begins to open, as well as the full-open temperature, can be determined. If the thermostat fails to respond at specified temperatures, it should be discarded. Specifications vary on different vehicles, but on one popular make, the opening temperature is 180° to 185°F, and the full-open temperature is 200° to 202°F. If the tests are satisfactory, the thermostat can be reinstalled. A new gasket, or gaskets in the case of some V-8 engines, should be used and the cap screws tightened to the specified torque. Then, the cooling system can be filled and the engine operated to check for leaks as well as proper thermostat action.

You should now have a good understanding of the service and repair requirements that pertain to cooling systems in general. However, it is good to remember that specific procedures or those peculiar to the system on a particular vehicle will require reference to the

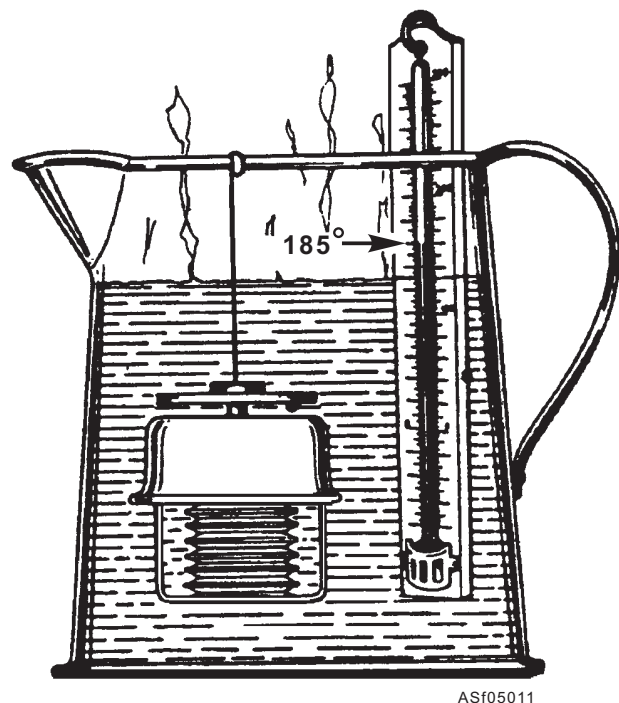

Figure 5-11.—Testing a thermometer.

applicable manufacturer's or other technical publications.

Q5-1. Which of the following components is NOT a component of an air-cooling system?

1. A shroud
2. A fins
3. A baffles
4. A blower

Q5-2. Which of the following components of a cooling system directs the flow of air over the engine to increase cooling efficiency?

1. The radiator
2. The fan
3. The shroud
4. The fins

Q5-3. An inner core is placed in a radiator on vehicles that contain which of the following components?

1. A diesel engine
2. An automatic transmission
3. A gasoline engine
4. A turbocharger

Q5-4. How many valves does a radiator pressure cap have?

1. One
2. Two
3. Three
4. Four

Q5-5. Which of the following components is located in the cylinder head outlet and designed to restrict coolant circulation?

1. A thermostat
2. A radiator
3. A check valve
4. A water jacket

Q5-6. To supplement the action of the thermostat and provide faster warm-up, stationary engines and large equipment are equipped with which of the following components?

1. A baffle
2. A shutter
3. A restriction orifices
4. An auxiliary water pump

Q5-7. Which of the following mixtures of ethylene glycol and water provides the engine with the maximum freezing protection?

1. 50-percent water and 50-percent ethylene glycol
2. 30-percent water and 70-percent ethylene glycol
3. 40-percent ethylene glycol and 60-percent water
4. 60-percent ethylene glycol and 40-percent water

Q5-8. When you perform a 0°F accuracy test on a hydrometer, which of the following ethylene glycol and water mixtures should you use?

1. One part ethylene glycol and one part water
2. Two parts ethylene glycol and one part water
3. One part ethylene glycol and two parts water
4. Two parts ethylene glycol and three parts water

ENGINE LUBRICATION SYSTEMS

LEARNING OBJECTIVES: Identify the components of gasoline and diesel engine lubrication systems. Identify procedures for inspecting, testing, and repairing lubrication system components. Identify troubleshooting procedures for gasoline and diesel lubrication systems. Identify procedures for repairing, removing, and replacing lubrication system components.

Almost all internal combustion engines are equipped with an internal lubrication system. Without lubrication, an engine would quickly overheat, and its working parts would seize or stick because of excessive friction. All the moving parts must be adequately lubricated to assure minimum wear and long engine life.

PURPOSES OF LUBRICATION

The primary function of engine lubrication is to reduce friction between moving parts. Lubrication

supplies a thin film of oil that prevents metal-to-metal contact, thus greatly reducing friction. The crankshaft, connecting rods, bearings, pistons, piston rings, valve stems, valve tappets, gears, drives, couplings, and bearings are the main parts that must be lubricated to guard against friction.

Helping to cool the engine is another function of the lubrication system. The oil goes through some very hot regions in the engine, and heat is absorbed by the oil, thus raising the oil temperature. The heat so absorbed is carried back to the oil pan, from which it is dissipated into the surrounding air.

Other purposes of lubricating oil are absorbing shocks between bearings and other engine parts, forming a seal between piston rings and cylinder walls, and helping to clean the engine parts.

As a shock-absorbing agent, oil around the piston bearings and journals acts as a cushion against the jars they receive from the hammer-like blows of the thrusts of the piston. A load of as much as one and a quarter tons is suddenly thrown upon the top of the piston when combustion takes place. This sudden thrust on the piston is carried through the piston pin and connecting rod bearings. Oil helps quiet the piston movement and reduces the wear of its parts.

Piston rings must form a gastight seal with the cylinder walls. The lubricating oil delivered to the cylinder walls helps in this respect. The oil film also provides lubrication of the rings so they can move

easily in the piston ring grooves and on the cylinder walls.

As oil circulates through the engine, it tends to wash off and carry away dirt, particles of carbon, and other foreign matter into the crankcase, where the larger particles drop to the bottom of the pan. The oil filter removes many of the smaller particles.

LUBRICATION SYSTEM COMPONENTS

All modern engines are lubricated under pressure. The oil supply is carried in the oil pan attached to the underside of the crankcase, from which it is drawn up and forced through a network of tubes, pipes, and drilled passages by the oil pump. The other main components of the system are the oil pressure gauge, the oil strainer, the oil filter, the oil level gauge, and the oil temperature regulator (oil cooler).

NOTE: Not all engines are equipped with oil coolers.

Oil Pump

The oil pump is the heart of the engine lubricating system. Depending on the type of engine, the pump will be mounted either inside or outside the crankcase. The two common types of oil pumps generally used in automotive engines are the gear and the rotary.

GEAR PUMP.—The gear pump (fig. 5-12) consists of two pump gears mounted within a close fitting housing. One of these two pump gears is driven

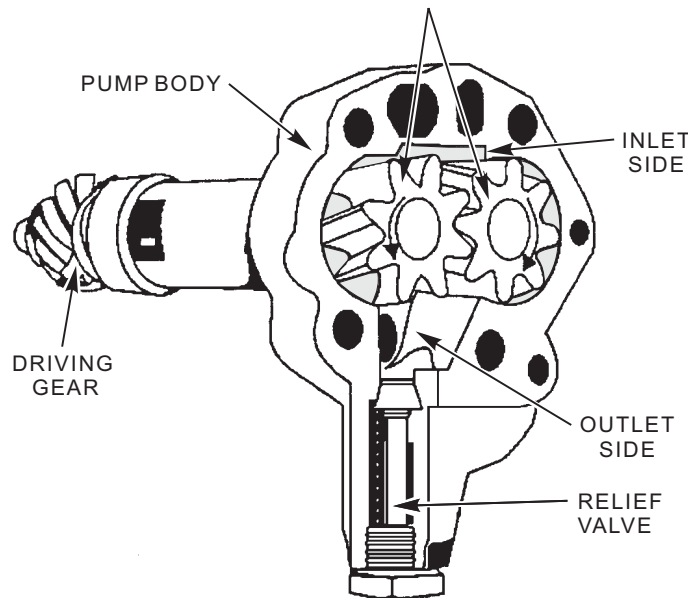

Figure 5-12.—Gear oil pump.

by the pump's drive shaft, which, in turn, actuates the other gear mounted on a stub shaft. The two gears are in mesh and rotate in opposite directions. Oil is picked up in the spaces between the gear teeth and the housing. This oil is then carried around to the pump outlet where it is discharged. Pressure is developed because of restrictions in the system caused by closely mated parts in the engine and pump. The gear pump may be driven directly from the camshaft or indirectly by the distributor.

ROTARY PUMP.—The rotary pump (fig. 5-13) has an inner rotor with lobes that match similar shaped depressions in the outer rotor. The inner rotor is off center from the outer rotor. As the inner rotor turns, it turns the outer rotor with it. As the two rotors turn, the openings between them are filled with oil. This oil is forced out from between the rotors as the inner rotor lobes enter the opening in the outer rotor. As you can see in figure 5-13, the inner rotor lobes have very little clearance as they approach the discharge. This allows the oil to be pressurized prior to discharge.

As a safety factor to assure sufficient oil delivery under extreme operating conditions, the oil pump is designed to supply a greater amount of oil than is normally needed for adequate lubrication. This requires that an oil pressure relief valve, usually incorporated in the pump, as shown in figures 5-12 and 5-13, be used in the system to prevent excessive oil pressure, especially at high speeds or when the oil is cold. The relief valve has a spring-loaded ball or plunger that is forced off its seat when the desired pressure, which ranges from 30 to 50 psi, is reached, allowing the excess oil to be delivered to the inlet side of the pump or to return to the crankcase through a drilled passage.

Oil Pressure Gauge

The oil pressure gauge is mounted on the instrument panel of the vehicle. Marked off on a dial in psi, the gauge indicates how regularly and evenly the oil is being delivered to all vital parts of the engine, and warns of any stoppages in this delivery. Pressure gauges may be mechanical or electrical. In the mechanical type, the gauge on the instrument panel is connected to an oil line tapped into the main oil supply passage leading from the pump. The pressure of the oil in the system acts on a diaphragm within the gauge, causing a needle to register on a dial. In the electrical type, the oil pressure operates a device on the engine that signals electrically to the pressure gauge, which indicates the oil pressure.

Some of the vehicles brought into the shop will not be equipped with an oil pressure gauge, but will have electrically operated warning lights on the instrument panel, which flash on and remain lighted to indicate low oil pressures.

Oil Strainers

Most engines use at least one oil strainer or screen in the lubrication system. The strainer must have a mesh suitable for straining out undesirable particles from the oil and yet pass a sufficient quantity of oil to the inlet side of the pump. The strainer is located so that all oil entering the pump from the oil pan must flow through it. Some screen assemblies also incorporate a safety valve, which opens in the event the screen becomes clogged, thus bypassing oil to the pump. Strainer assemblies may be either the floating or the fixed type.

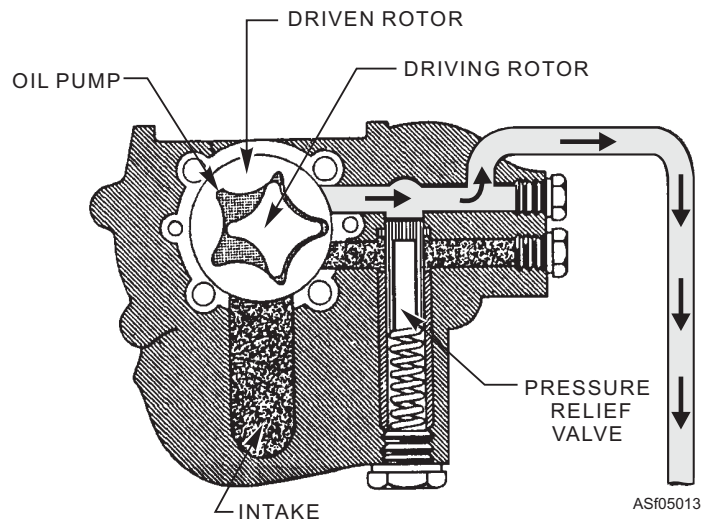

Figure 5-13.—Rotary oil pump.

FLOATING STRAINER.—The floating strainer has a sealed air chamber, is hinged to the oil pump inlet, and floats just below the top of the oil. As the oil level changes, the floating intake will rise or fall accordingly. Thus, all oil taken into the pump comes from the surface. This prevents the pump from drawing oil from the bottom of the oil pan, where dirt, water, and sludge are likely to collect. The strainer screen is held to the float by a holding clip, and the up or down movement of the float is limited by stops.

FIXED STRAINER.—The fixed strainer is simply an inverted funnel-like device, as shown in figure 5-14, placed about 1/2 inch to 1 inch from the bottom of the oil pan. Thus, any sludge or dirt accumulation in the bottom of the pan is prevented from circulating through the system. The assembly is attached solidly to the oil pump in a fixed position.

Oil Filters

The oil cleaner, or filter, is placed in the oil line beyond the pump and is usually mounted on the engine in an accessible location. The average automotive engine uses a single filter while larger engines, especially diesel, use banks of two or more filters.

The filter cleans the oil and removes most of the impurities that were picked up by the oil as it circulated through the engine. The filter is connected so that the oil passes through it each time the oil is circulated through the engine. Some oil filters have washable filter elements and some have replaceable elements or cartridges, while still others require replacement of the entire assembly.

The elements themselves may be either metallic or nonmetallic. The metallic elements are made of bronze and are more or less permanent, since they are washable. Nonmetallic filter elements are composed

of paper or a composition of paper and other materials, and must be replaced periodically.

FULL FLOW FILTERS.—Full flow filters (fig. 5-15) are designed to filter the full oil output of the pump. This type of filter strains all of the oil before it is distributed to the engine.

With the full flow type filter, a relief or bypass valve must be provided to allow the oil to flow around the filter in the event the filter becomes clogged. This valve opens when the back pressure caused by clogging becomes greater than the tension of the valve spring. The engine is thus assured an adequate supply of oil in case of filter failure. The bypass valve is incorporated in the filter assembly or located in the engine block near the filter.

PARTIAL FLOW FILTERS.—Partial flow filters (fig. 5-16) strain only a small amount of the oil being circulated by the pump. The oil from the main oil gallery enters the filter and flows through the filter element. It then passes into the metal perforated collector in the center of the filter. The filtered oil then flows out the outlet, which is restricted to prevent loss of pressure. After passing through the restriction, the oil either returns to the crankcase directly or by way of the timing gears, rocker arms, or other parts needing lubrication. Where the return oil is used for lubricating such parts, a bypass valve must be used to assure circulation in the event the filter becomes clogged. A drain plug is usually incorporated in the bottom of the filter case for sludge removal.

Oil Level Gauge

The oil level gauge, known also as a dipstick, is usually of the bayonet type. It consists of a long rod or blade that extends into the oil pan. It is marked to show EMPTY, LOW, and FULL, or sometimes just LOW and FULL or FULL and ADD. Readings are taken by

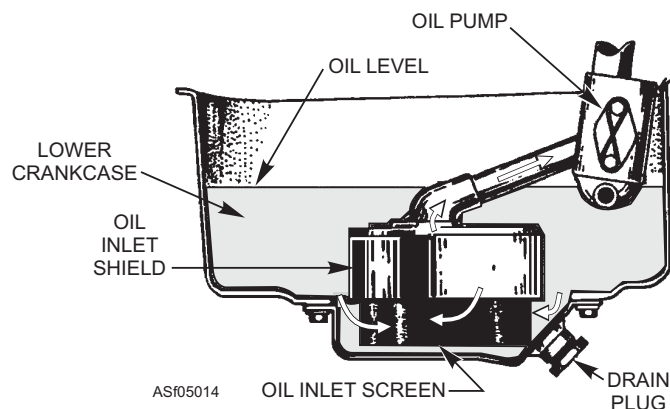
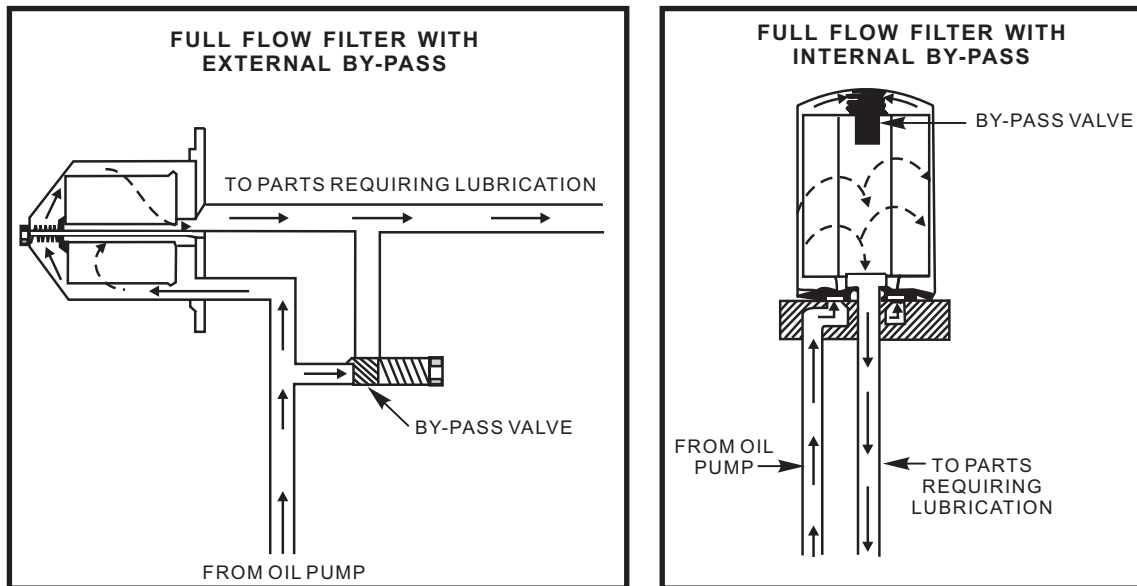
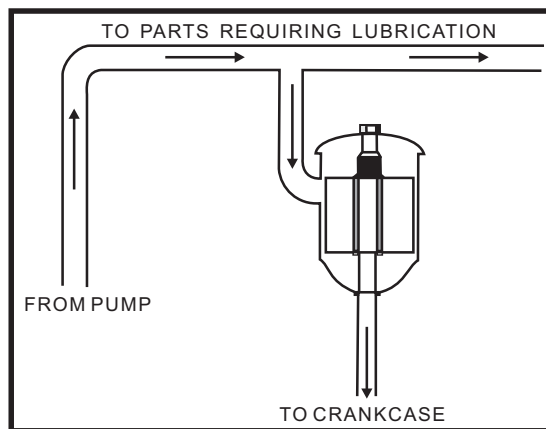

Figure 5-14.—Fixed oil strainer.



ASf05015

Figure 5-15.—Full flow filters.



ASf05016

Figure 5-16.—Partial flow filter.

pulling the rod out from its normal place in the crankcase, wiping it clean, replacing it, and again removing and noting the height of the oil on the lower or marked end. This should be done with the engine stopped unless the manufacturer recommends otherwise. It is very important that the oil level not drop below the LOW mark or rise above the FULL mark.

Oil Temperature Regulator

The oil temperature regulator, found mostly in diesel engine lubricating systems, prevents the temperature of the oil from rising too high in hot weather. The regulator unit (fig. 5-17), which makes use of the water in the cooling system, is made up of a core and a housing. The core, through which the oil circulates, is exposed to the water that circulates

through the housing. As the oil passes through the regulator, it is either cooled or heated, depending on the temperature of the water in the cooling system. From the regulator, the oil enters the oil passages that lead to the engine parts.

Some support equipment engines use an oil cooler that consists of a radiator through which air is circulated by movement of the vehicle and the cooling fan. This radiator, through which oil passes to and from the oil pan through the engine passages, acts only to cool the oil.

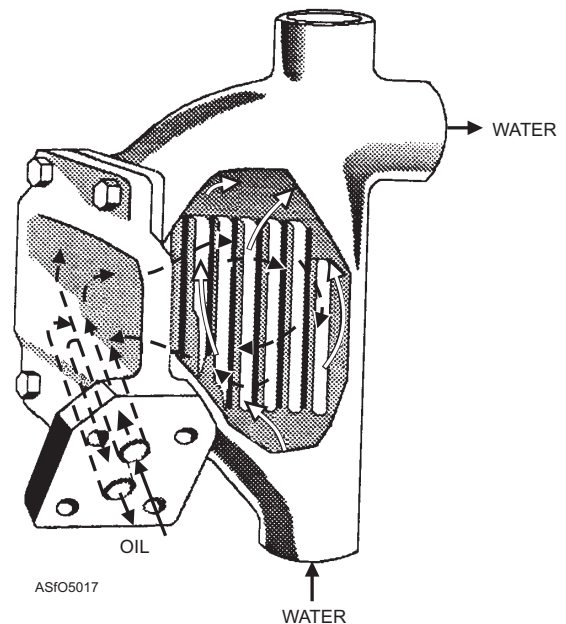

ASf05017

Figure 5-17.—Oil temperature regulator (cooler).

TYPES OF LUBRICATION SYSTEMS

Now that you are familiar with the lubrication system in general, you are ready to study the different methods used to circulate oil through the engine. The systems used to circulate oil are known as force-feed, full force-feed, splash, and combination splash force-feed.

Force-Feed

The force-feed (or pressure-feed) system (fig. 5-18) forces oil from the crankcase to the main bearings, camshaft bearings, and connecting rod bearings. The oil enters a line or a channel from the pump and then flows to the crankshaft bearings, which, in turn, feed the oil into drilled passages in the crankshaft. From these passages it flows through holes in the connecting rods. The cylinder walls, pistons, and piston pins are lubricated by the oil thrown off from the connecting rods.

Full Force-Feed

In the full force-feed system (fig. 5-19), all bearings, as well as the pistons and piston pins, are lubricated by oil under pressure from the pump. Oil enters the crankshaft oil passages, passes to the connecting rod bearings, enters holes drilled in the connecting rods, goes up through the rod passages to the piston pin bearings, and helps lubricate both the pistons and the cylinder walls.

Splash

In the splash system, dippers on the connecting rods enter the oil in the crankcase with each revolution

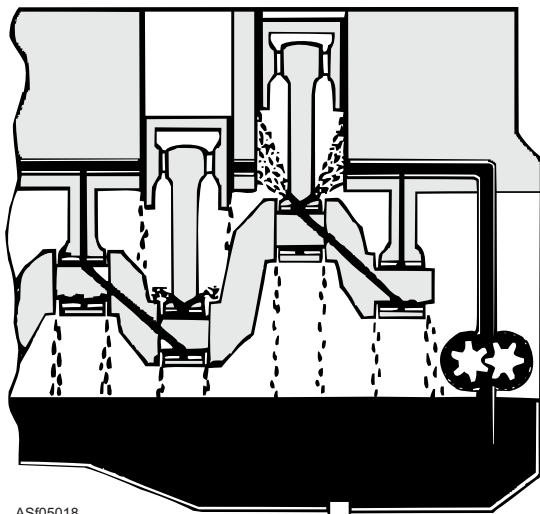

ASf05018

Figure 5-18.—Force-feed lubrication system.

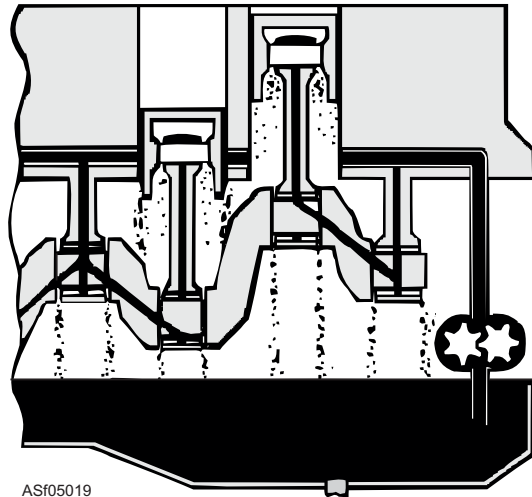

ASf05019

Figure 5-19.—Full force-feed lubrication system.

of the crankshaft and splash oil to the upper parts of the engine. The oil, thus thrown upward in droplets and mist, provides lubrication for the valve mechanisms, piston pins, and other moving parts. The splash system is rarely found on modern engines, because its lubricating effect is too uncertain to meet today's heavy operating demands. On a full crankcase, it could mean over lubrication and a waste of oil, while on a partly filled crankcase, it could cause inadequate lubrication and failure of the engine.

Combination Splash Force-Feed

The combination splash force-feed system (fig. 5-20), as the term implies, depends on oil splash and pressure to accomplish engine lubrication. The oil pump forces oil under pressure to the main and camshaft bearings and the valve mechanisms. The connecting rods, the pistons, piston pins, and cylinder walls are lubricated by dippers splashing oil into the

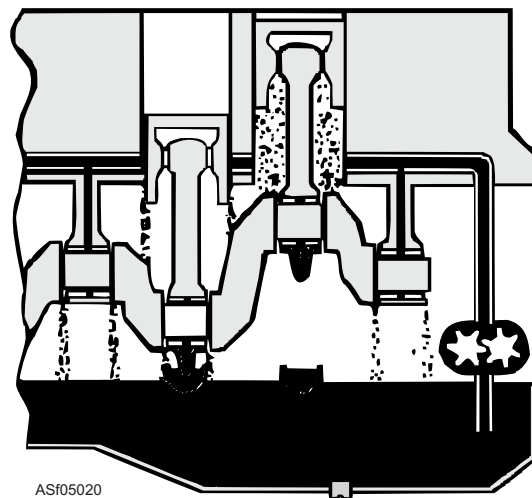

ASf05020

Figure 5-20.—Combination splash force-feed lubrication system.

troughs underneath the connecting rod bearing caps. These troughs are kept filled by the oil pump, which delivers the oil through nozzles.

CRANKCASE VENTILATION

There are two reasons for crankcase ventilation during normal operation. It removes gasoline and water that trickle into the crankcase during the normal process of combustion; such gas and water mixes with the oil and forms a pasty sludge if allowed to remain in the crankcase. Ventilation also allows the crankcase to breathe in order to eliminate excessive pressure in the crankcase.

There are two methods of eliminating gasoline and water from the crankcase—the non-positive method and the positive method. The non-positive method depends on a breather tube. Air flows past the open end of the tube, evaporating the water and the gasoline and removing the vapors from the crankcase. One end of the breather tube opens into the crankcase above the oil level. The other end extends down under the vehicle, where there is sufficient airflow to create a low pressure at the open end of the tube (fig. 5-21). The pressure differential between the crankcase and the open end of the tube is sufficient to force any vapors out of the crankcase. Some breather tubes are placed so that the cooling fan will increase the flow of air passing over them, increasing their ventilating abilities.

In the positive method, air is drawn through the engine by an intake manifold vacuum; or, in other words, the intake manifold vacuum draws air through the crankcase to sweep vapors out of it (fig. 5-22). After picking up these vapors as it circulates through the crankcase, the air is forced upward and out of the engine through an opening in the valve cover, and it is then drawn through a tube connected to the intake manifold.

To promote vaporization of volatile impurities and their removal from the crankcase, the operating temperature of the engine should be at least 140°F.

LUBRICATION SYSTEM MAINTENANCE

Lubrication system maintenance normally consists of changing the oil and filters. Occasionally you might be required to perform such maintenance tasks as replacing lines and fittings, servicing the oil pump and relief valve, and flushing the system.

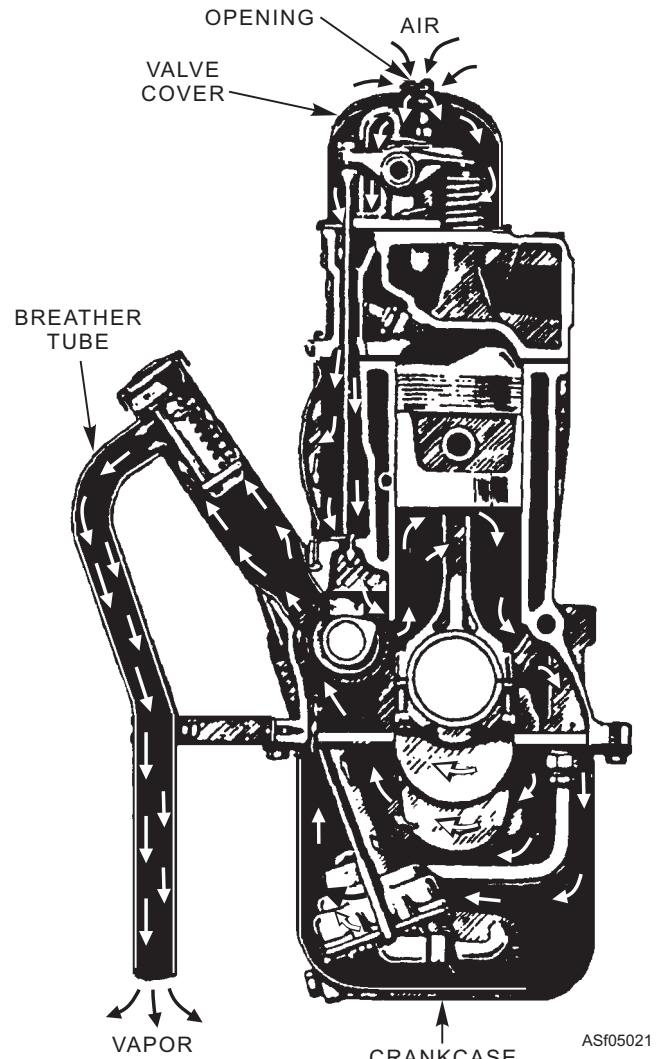

Figure 5-21.—Crankshaft breather tube.

Oil and Filter Change

Whenever the engine oil feels gritty when rubbed between your fingers or has no body, it has lost its lubricating qualities and should be changed. In any case, oil and filter changes are made in accordance with periodic maintenance (PM) schedules. On most of your equipment, the grade and quantity of the oil to be used can be found on the MRC or in the technical manual. The oil should be changed more frequently in cold weather and in vehicles operated under dusty or other very unfavorable conditions. Your chief or leading petty officer will give you specific directions about oil changes on such vehicles.

Drain the oil only after the engine has been run and is warmed up. This warm-up period will thin the oil and stir up the sludge and foreign matter in the oil pan. Cold oil is thick and will not drain readily, and

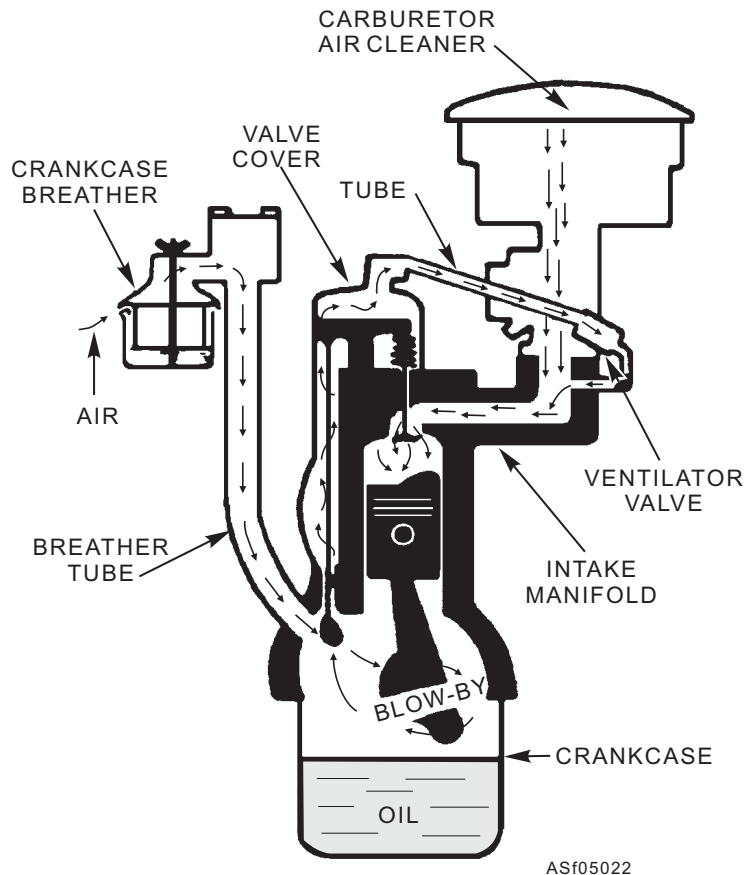

Figure 5-22.—Positive crankshaft ventilation.

foreign matter tends to stick to the sides of the oil pan when the engine is cold. Usually, the filter elements are changed at the time the oil is changed in the crankcase. On new engines, the oil may be changed after running the engine for only a short period of time. This ensures that the engine is broken in with the cleanest oil possible and that all contaminants are removed during break-in, according to the manufacturer's instructions or according to shop policy. The filter element should be replaced with the type recommended by the manufacturer. Be sure to remove the old gasket and make sure that the new gasket under the cover or in the crankcase is properly fitted.

In replacing the filter element, remove the drain plug from the bottom of the housing. Next, remove the cover by loosening the center bolt or clamp. Now lift out the old element, and wipe the inside of the housing with a clean cloth. Some filter housings do not have drain plugs. Therefore, you must first remove the cover. Next, remove the filter element and take out the dirty oil with a siphon gun, and then wipe the inside of the housing with a clean lint free cloth. Remove all traces of dirt or lint that remain inside. Install the new element. Finally, replace the drain plug and the cover,

using a new gasket, or just the gasket and cover on filter housings without drain plugs.

On the type of filter that does not have a replaceable element, disconnect the oil lines to the old filter, dismantle the filter, install the new one, and reconnect the oil lines.

The screw-on type of filter, which is disposable, has an integral gasket. Installation instructions are printed right on the filter or included in the carton. The greatest danger with this filter is installing it too tight.

After filling the oil pan with new oil, recheck the oil level to be certain that the oil column reaches the FULL marking on the dipstick. Then, run the engine for a few minutes to ensure no leaks exist, particularly around the oil filter housing and the oil drain plug. Get into the habit of looking at the ground or pavement over which a vehicle has been parked for any oil spots that may indicate leakage.

Ordinarily, low oil pressure readings may be due to thin or diluted oil, excessive heating, an improper grade of oil, or a low oil level in the oil pan. If no pressure shows, or if the pressure is erratic even after replacing the old oil with new of the proper grade, a defective oil gauge may be the cause. If so, it is usually

better to replace the entire gauge unit than attempt repairs.

Persistent low-pressure readings or a zero reading could point to trouble in the oil pump. While a complete failure of the oil pump is rare, any wear of its moving parts is likely to impair its efficiency.

High-pressure readings may be observed while the engine is warming up in cold weather, before the oil has reached operating temperature. After a brief warm-up period, the gauge indicator should return to normal. A persistent high-pressure reading points to the possibility of a clogged oil line or a poorly operating pressure relief valve.

Servicing Oil Lines, Fittings, and Strainers

Oil lines and fittings must be maintained so as to prevent leakage and loss of oil pressure. Where lines are leaking at connections, you can make corrections by tightening the fittings or couplings. Be sure to use two wrenches as with fuel lines. Leaks in a line, whether flexible or rigid, require replacement of the line. Lines showing evidence of cracks or deterioration should also be replaced.

It is essential that the oil strainer be kept clean to permit free flow of oil to the pump. The need for cleaning is sometimes indicated by lowered oil pressure. When cleaning a strainer, you should note any deposits, since they may furnish valuable clues as to the engine condition. Metal bearing particles, for example, indicate deterioration of some bearing or journal. To service the strainer, remove the oil pan; clean the fine-mesh bronze strainer by using solvent and a brush, and then dry with compressed air. If the screen is damaged, it must be replaced. In the case of the floating-type strainer, you should also make sure it is not binding.

Oil Pump and Relief Valve

Service on oil pumps and most relief valves is rather limited, since they are relatively trouble free. An oil pump will often still be operating effectively when the vehicle is ready for salvage. Thus, when low oil pressure or lack of oil pressure develops, you should not immediately assume that the pump is at fault. More commonly, the trouble is caused by an inaccurate or inoperative oil pressure gauge, oil of too low viscosity, high engine operating temperatures, cracked or clogged lines or screens, or a malfunctioning relief valve. However, where the oil pump is found to be at fault, it will be necessary to remove it and either repair

or replace it. Most often the pump is replaced with a new or factory rebuilt pump.

To replace the oil pump, it is first necessary to determine its location and method of drive. The pump may be located either in the oil pan or outside on the lower part of the crankcase, and driven either directly by the camshaft or indirectly via the distributor shaft. Those driven indirectly from the distributor shaft are easily replaced regardless of their location. The directly driven pumps, on the other hand, pose a problem, since they usually drive the distributor. The procedure for removing and replacing a pump of this type is outlined in the vehicle's maintenance manuals. The quickest way to find out how an engine's pump is driven is to check the manual. The next best and most expedient method is to lift the distributor and look at its shaft. If it has a gear, it drives the pump, and removal of the pump will not affect timing. On the other hand, if it has a slot or driving lug instead of a gear, it is driven by the pump shaft. The general procedure in the latter case is to remove the distributor cap and crank the engine until the rotor is aimed at the No. 1 cylinder. Align the timing marks (flywheel or crankshaft front pulley). Then proceed with the removal of the oil pump.

In replacing the pump, simply index its drive gear so that the clutch or driving lug on the distributor and pump shafts will align and mesh without movement of the distributor shaft (or at least with a minimum of movement). If it moves, the ignition must be re-timed. Under no circumstances should you ever drive or force an oil pump into or out of place. Instead, find out what is holding it; a safety pin or burr on a casting are the most frequent causes. Also, when replacing either the gear or rotary pump, you should always fill the pumping chamber with oil. The pumps need that oil to effect a positive seal and to prime them. A new gasket should be used and the retaining screws tightened as specified.

Cleaning and adjusting is all that is usually required on the relief valve, although some types are nonadjustable. A relief valve is cleaned to prevent or cure sticking. The plunger or valve must be free to move one way or the other under pressure from the oil or spring. A relief valve may be adjusted in one of two ways. It may be done with an adjusting screw (having a jam or locknut), which either adds or relieves pressure on the spring, or it may be done by adding or removing shims or by replacing the spring with one of a different strength. In either case, you should follow the manufacturer's recommendations.

Q5-9. What is the secondary purpose of the lubrication system?

- 1. To provide corrosion protection for internal components*
- 2. To assist in faster warm-up time of the engine*
- 3. To help cool the engine*
- 4. To remove dirt from the engine*

Q5-10. Which of the following components is the heart of the lubrication system?

- 1. The oil pan*
- 2. The oil rings*
- 3. The oil sump*
- 4. The oil pump*

Q5-11. What are the two types of pumps used in an engine lubrication system?

- 1. A rotary or gear pump*
- 2. A rotary or reciprocating pump*
- 3. A positive displacement or gear pump*
- 4. A direct drive or positive displacement pump*

Q5-12. Which of the following components, found mostly in diesel engines, prevent the oil temperature from rising too high in hot weather?

- 1. An oil pan with cooling fins*
- 2. An oil temperature regulator*
- 3. An oil temperature thermostat*
- 4. An oil pan with baffles*

Q5-13. What is the function of crankcase ventilation in a gasoline engine?

- 1. It provides a way for air to enter the intake manifold*
- 2. It eliminates excessive pressure in the crankcase*
- 3. It allows sufficient airflow to create a higher pressure at the open end of the breather tube.*
- 4. It creates a positive back pressure inside the crankcase.*

CHAPTER 6

AUTOMOTIVE ELECTRICAL SYSTEMS AND EQUIPMENT

INTRODUCTION

Support equipment (SE) technicians are required to maintain automotive electrical systems. For this reason, you are required to have a thorough understanding of automotive electrical systems and associated equipment. With this knowledge, you will be able to correctly diagnose electrical malfunctions and take the required corrective action. A lack of understanding on your part can result in wasted man-hours and additional damage to the equipment.

The electrical systems of most automotive equipment have two functions. One function is to supply the electrical energy that is required to crank and operate the engine. The other function is to supply power for lights, heaters, electrical accessories, instruments, and gauges.

You will be introduced to the full range of automotive electrical systems, which include batteries, charging systems, ignition systems, starting systems, generators, alternators, and auxiliary systems, such as lighting and instruments. However, this course does not cover basic electricity. If you require further study of electricity, refer to the Navy Electricity and Electronics Training Series (NEETS). These training courses (called modules) cover every aspect of electricity that you will need on the job. Although you are not required to complete the series to take the advancement exams, many of the modules are on your bibliography and are used by the exam writers in preparing your advancement exams. A well prepared candidate will study the NEETS modules extensively.

DRAWINGS AND DIAGRAMS

LEARNING OBJECTIVE: Identify basic automotive electrical circuits. Identify the schematic symbols used in electrical circuits. Recognize electrical safety precautions.

















To become proficient in your rating, you must be able to locate parts on equipment, trace circuits, and learn the operation of many systems and components. Drawings and diagrams are used to make this task

easier. Therefore, you must understand and use the drawings and diagrams that are a part of your job.

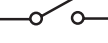
No one particular type of illustration is suitable for all applications, so you will encounter many different types. Additional information on drawings and diagrams may be found in *Blueprint Reading and Sketching*, NAVEDTRA 14040, and NEETS, Module 4, NAVEDTRA 14176.

SCHEMATIC DIAGRAMS

As an AS, your main aid in troubleshooting a circuit in a piece of equipment is the schematic diagram. The schematic diagram is a “picture” of a circuit that uses symbols to represent components in the circuit. Circuits that are physically large and complex can be shown on relatively small diagrams. You should be familiar with the basic schematic symbols shown in figure 6-1.

 WIRE	 LAMP INCANDESCENT
CONDUCTORS  CONNECTED  CONNECTED  NOT CONNECTED	 FUSE RESISTORS  FIXED  VARIABLE (POTENTIOMETER)  RHEOSTAT
 GROUND	 SWITCH
 CELL	 VOLTMETER
 BATTERY  OR	 AMMETER

ASF06001

Figure 6-1.—Symbols commonly used in electricity.

The major purpose of a schematic diagram (fig. 6-2) is to establish the electrical operation of a particular system. It is not drawn to scale and shows none of the actual construction details.

The schematic diagram is not your only tool in troubleshooting electrical circuits. Wiring diagrams are also available to help you better understand system operation.

WIRING DIAGRAMS

Wiring diagrams (fig. 6-3) present detailed circuitry information concerning electrical systems. A master-wiring diagram is a single diagram that shows all of the wiring in a complete system. In most cases, this diagram is too large to be usable. It is normally broken down into logical functional sections, each of

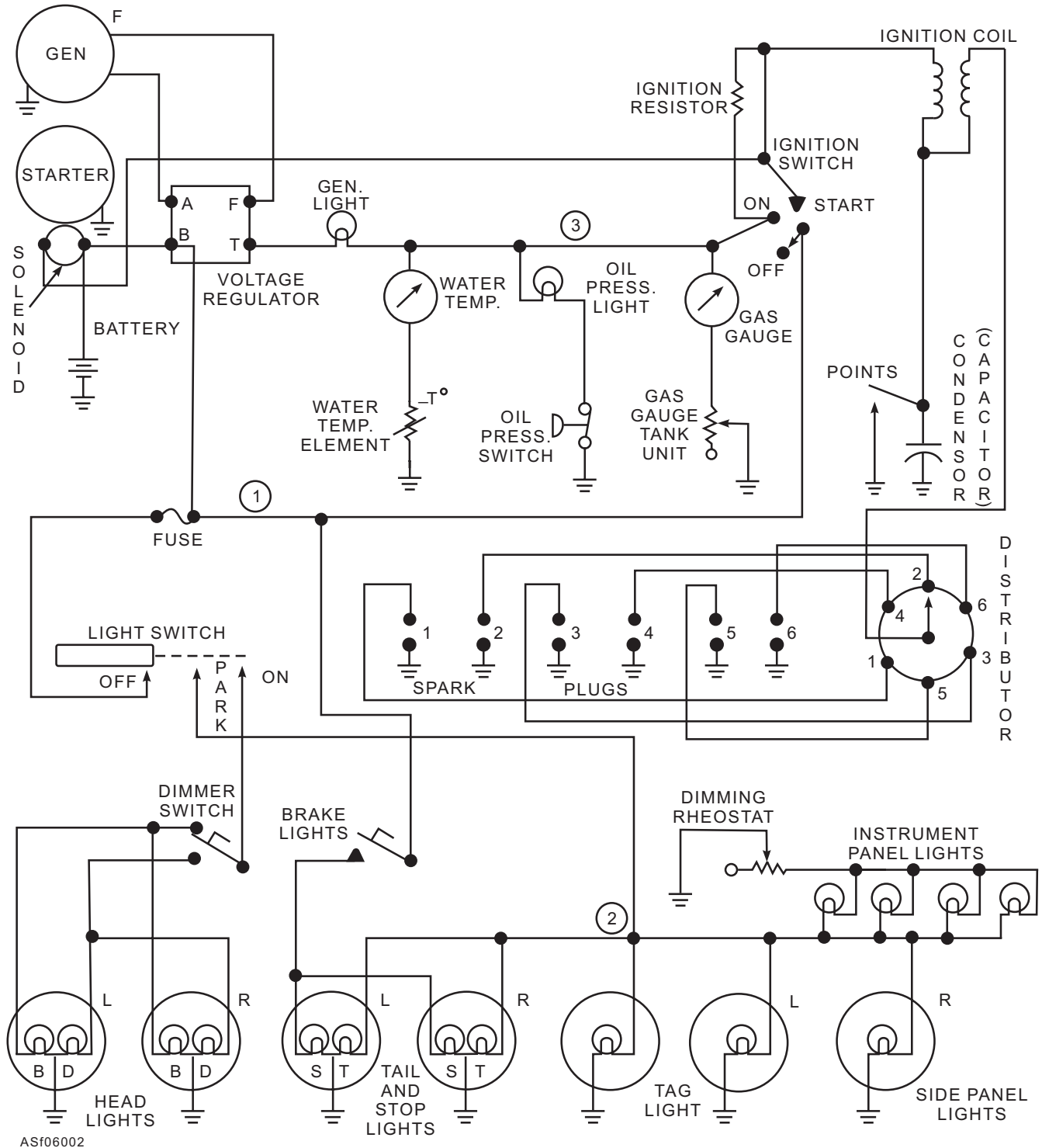
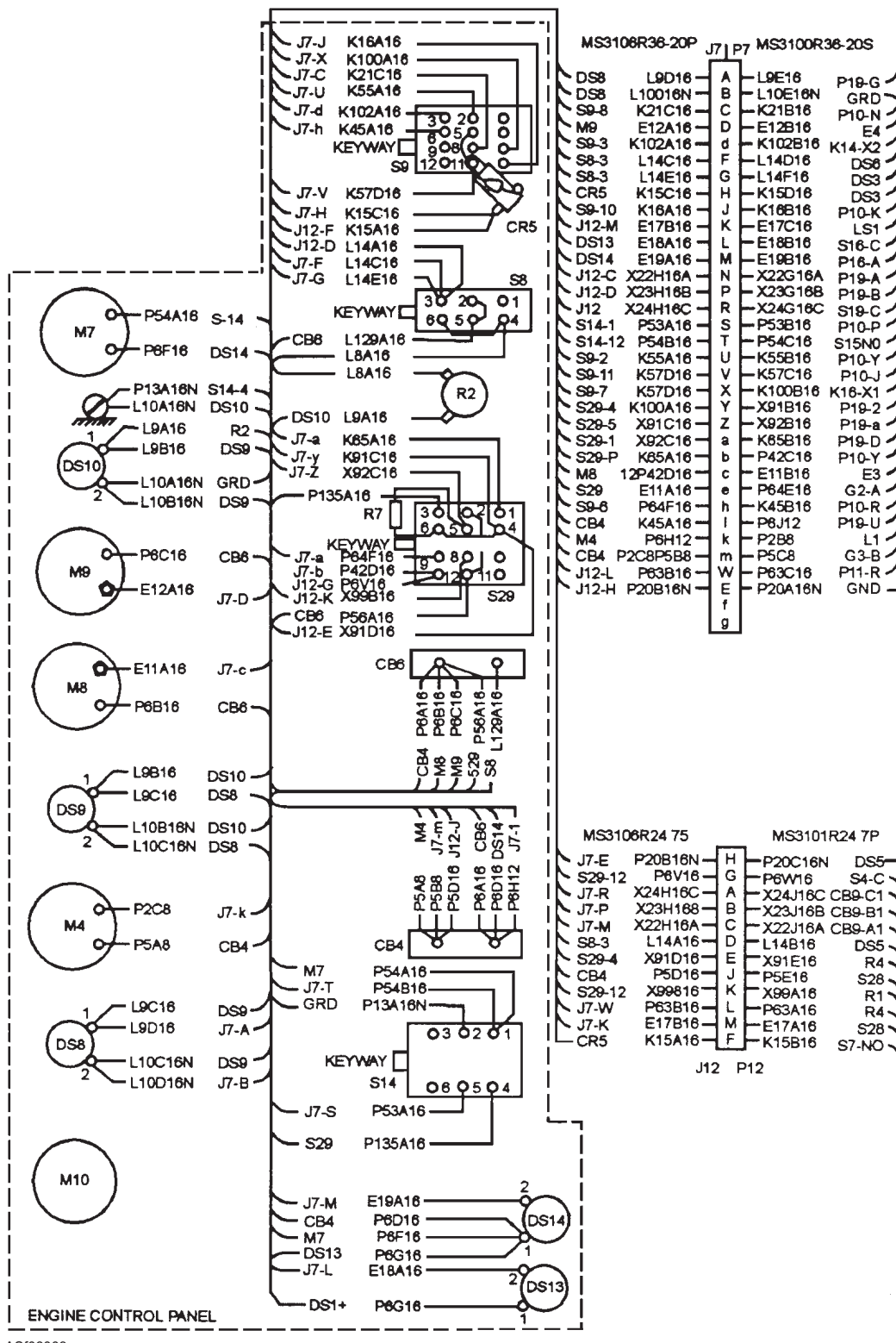

Figure 6-2.—Schematic diagram.



ASF06003

Figure 6-3.—Wiring diagram.

which may be further subdivided into circuit diagrams. By breaking a system into individual circuit diagrams, each individual circuit may be presented in greater detail. The increased detail provides for easier circuit tracing, testing, and maintenance.

The wiring diagram shows in detail how a wire is routed between components and the approximate physical location of the component. Each segment of the complete wire is shown, along with its identification number or color code, as well as each plug or terminal strip used.

The master-wiring diagram is normally consulted when replacing sections of wiring, when determining how the circuits are tied together, and when making drawings of systems or circuit wiring diagrams.

A system or circuit wiring diagram, similar to the one shown in figure 6-3, is used when testing or troubleshooting a circuit. The idea is to use the smallest diagram that provides the necessary information to perform the particular task.

Q6-1. Which of the following diagrams is designed to establish the electrical operation of a particular system?

1. A block diagram
2. A schematic diagram
3. A wiring diagram
4. An electrical diagram

Circuit function letter	Circuits
A	Armament
B	Photographic
C	Control surface
D	Instrument
E	Engine instrument
F	Flight instrument
G	Landing gear
H	Heating, ventilating, and deicing
J	Ignition
K	Engine control
L	Lighting
M	Miscellaneous
P	DC power Wiring in the DC power or power control system will be identified by the circuit function letter P.
Q	Fuel and oil
R	Radio (navigation and communication) RN-Navigation RP-Intercommunications RZ-Interphone, headphone
S	Radar SA-Altimeter SN-Navigation SQ-Track SR-Recorder SS-Search
T	Special electronic TE-Countermeasures TN-Navigation TR-Receivers TX-Television transmitters TZ-Computer
V	DC power and DC control wires for AC systems will be identified by the circuit function letter V.
W	Warning and emergency
X	AC power Wiring in the AC power system will be identified by the circuit function letter X.
Y	Armament special systems

AS06004

Figure 6-4.—Codes for wiring functions.

Q6-2. The primary purpose of a wiring diagram is to perform which of the following functions?

1. It shows basic component relationship and component location using geometric shapes and symbols
2. It shows, in detail, the electrical operation of a particular circuit
3. It shows electrical wire routing between components and the approximate physical location of the components
4. It shows how each component is electrically connected to other components in the system and how they electrically affect each other

ELECTRICAL WIRING

LEARNING OBJECTIVES: Identify basic electrical wiring diagrams and their symbols. Identify color-coding and numbering schemes for electrical wires.

Ground support equipment has to meet certain standards, but there are no set specifications or standards for identifying the wiring used in the equipment. The older, less complicated equipment had few markings, no markings, or was poorly marked. In the newer, more complex or special support equipment, the wiring is well marked.

Various methods of identification are used. Manufacturers are now using wiring identification codes similar to those used in aircraft.

COLOR CODES

Most automotive vehicle wiring is made up as a harness, with all leads coming out at the proper places and with the correct lengths to connect to the accessories. This simplifies the wiring of the automotive vehicle and serves to protect the wiring. To

permit easy identification of the various leads, a color code in the insulation is widely used. You should consult the applicable support equipment manual or handbook for the proper selection of wiring harness and the proper color code for the vehicle that you are maintaining. Examples of the automotive color codes are as follows:

RED LEAD. This color identifies wires that are connected to the battery (not fused), wires that are between the generator and the regulator, or wires that are between the ammeter and the circuit breaker/fuse.

RED LEAD WITH YELLOW TRACER. These colors identify the primary ignition lead.

RED LEAD WITH BLACK TRACER. These colors identify the wires between the ammeter and the battery.

YELLOW LEAD. This color identifies the horn and light circuits (fused).

BROWN LEAD WITH BLACK TRACER. These colors identify all ground connections except the battery ground.

BLACK LEAD. This color identifies the wires that connect the taillights to the light switch.

BLACK LEAD WITH RED TRACER. These colors identify the headlight circuit for high or bright beams.

GREEN LEAD. This color identifies the headlight circuit for low or dim beams.

ALPHANUMERIC CODE

The alphanumeric code consists of a combination of letters and numerals imprinted on each wire at prescribed intervals along its entire run. Figures 6-4 and 6-5 and the accompanying discussion explain the codes used in wiring installations. Complete details may be

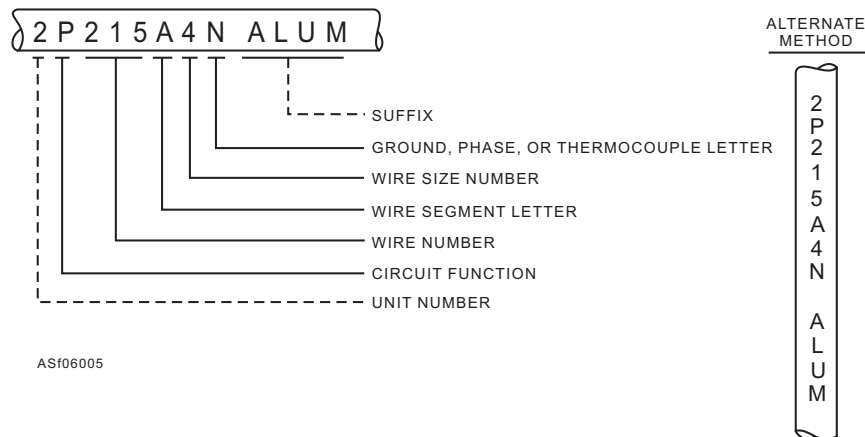

Figure 6-5.—Alphanumeric wire identification code.

found in Military Specifications, MIL-W-5088, which may be found in your technical library.

The first character in the alphanumeric code is a prefix (numeral), and is referred to as the unit number. The unit number is used only in those cases where more than one unit is installed in an identical manner in the same equipment. The wiring concerned with the first such unit bears the prefix 1, and corresponding wires for the second unit have exactly the same designation, except for the prefix 2. In the wire identification code shown in figure 6-5, the 2 denotes that it is the second of at least two identical systems in the equipment.

The letter following the prefix number identifies the circuit function. You are primarily concerned with function letters *D*, *E*, *L*, *P*, *V*, and *X*. The letter *D* denotes instruments; *E* denotes engine instruments; *L* denotes lighting; *P* denotes dc power; *V* denotes dc power and dc control for ac systems; and *X* denotes ac power. These are identified in the wiring circuit function code.

The wire number that follows the circuit function consists of one or more digits and differentiates between wires in a circuit/circuits. A different number is used for wires that do not have a common terminal or connection, such as through a circuit breaker, switching device, or load.

Wires that are segmented by the use of connectors or terminals are given different segment letters. Normally, the segment letters are in alphabetical sequence, beginning at the power source. The letters *I* and *O* are not used because they could be mistaken for the numerals 1 and 0. In the code shown in figure 6-5, the letter *A* signifies the first segment of wire 215. The number following the segment letter identifies the size of the wire or cable.

The ground, phase, or thermocouple letter following the wire size number is used only when the segment of wire pertains to one of these items. You are primarily concerned with the letters *N*, *A*, *B*, and *C*. The letter *N* denotes a neutral wire; *A*, *B*, and *C* denote the three separate phases of an ac power supply or source.

The suffix letters at the end of the code are an abbreviation of the material of which the wire is made. ALUM indicates the wire is made of aluminum.

Another method of wire and cable identification may use the complete wire identification coding or only the wire number and segment letter on the wiring in the equipment and on the diagrams for that equipment. If this method is used, the operation and service instruction section of the technical manual contains a

wiring list from which these wire numbers can be cross-referenced to obtain information on the wiring. This list contains valuable information that can be used in several different ways. For example, the wiring list may contain the following:

- Complete wire identification code or only the wire numbers and segment letters
- Wire gauge size of the wire
- Length of the wire in inches
- Component and terminal from which the wire leaves
- Component and terminal to which the wire is attached

Figure 6-6 shows an example of wiring identification code use.

WIRING HARNESS

The wiring harness is a number of insulated wires grouped together. They may be braid covered or secured in a nonmetallic tape. The wiring harness should be securely mounted to prevent chafing, loosening of wire terminals, and breakage due to vibration. The wires are color-coded or numbered and cut to the proper lengths to make connections with various electrical components.

Wire Support and Protection

Wires in the electrical systems should be supported by cleats, clamps, or brackets at various points about the vehicle. When you are installing a new wire, be sure to keep it away from hot engine parts, which could scorch or burn the insulation. Wires passing through holes in metal members of the frame or body should be protected by rubber grommets or several turns of friction tape to prevent chafing or cutting on sharp edges.

Ground Connections

Make certain the ground return connections made to the chassis frame or engine are clean and tight. Where the engine or body is mounted on rubber or other insulating material, use flexible bonding wires to connect the parts together. Pay particular attention to these areas because rust or corrosion may form at these connections, preventing the flow of current in the circuits even though the screws or bolts are tight.

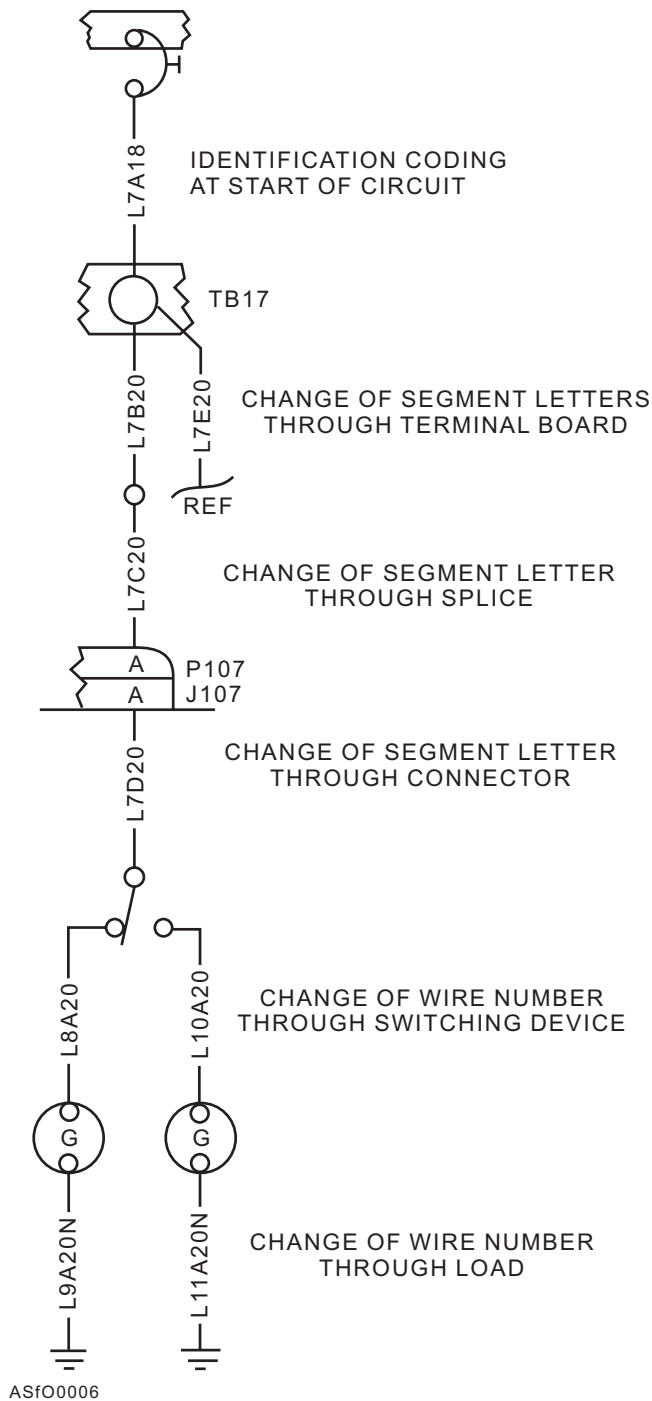

Figure 6-6.—Example of wire identification code use.

GROUNDING SYSTEMS

Almost all of the electrical and electronic circuits you work with are grounded. This means that one leg of the circuit is connected to a common conductor, such as a structural member (frame) of the equipment. When the grounded leg of the circuit is connected to a good electrical conductor, this conductor may serve as one leg of the circuit. No separate conductor is needed for this leg of the circuit.

Figure 6-7 shows a simple grounded system. Even though the grounds are shown at different points, the potentials at these points are essentially the same since they are connected to a common conductor.

Any wire that completes the circuit to the ground network for the equipment is designated with the letter *N*. Any wire so designated may come in contact with ground at any point without causing malfunctions to the equipment.

A grounded circuit has advantages since it reduces overall weight by using fewer conductors. This results in a reduction in cost and space requirements. Other advantages are that troubleshooting is simplified to some extent and the impedance of the ground return path is lower than that of a wire conductor. The grounded system also has disadvantages. Short circuits result when a bare spot on any ungrounded conductor touches ground.

UNGROUNDING SYSTEMS

The term *ungrounded system* means that the circuit is in no way connected to ground. All conductors are run from the power source to the loads. Circuits of this type are often referred to as being above ground. The ungrounded system has a number of advantages. It prevents one circuit from feeding into another. No malfunction of equipment occurs should one conductor become accidentally grounded. The circuits are completely insulated from each other. The system has the disadvantage of adding more weight because it requires more conductors than the grounded system. This results in added cost and space requirements.

ELECTRICAL SAFETY PRECAUTIONS

We do not normally do repair work on energized circuits. But, when repairs on operating equipment must be made, the work should be done only by experienced personnel under the supervision of the senior petty officer of the work center, if possible. Every known safety precaution should be carefully

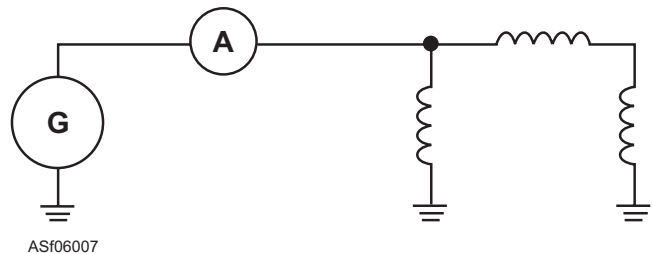

Figure 6-7.—Grounded system.

observed. Ample light for good illumination should be provided. The worker should be insulated from ground with a suitable nonconducting material, such as a rubber mat of approved construction. The worker should, if possible, use only one hand in accomplishing the necessary repairs. Helpers should be stationed near the main switch or the circuit breaker so the equipment can be de-energized immediately in case of emergency. A person qualified in first aid for electric shock should stand by during the entire period of the repair. Also, NAVOSH 29 CFR 1910 requires at least one CPR-qualified person in each work center that performs electrical repairs.

High-Voltage Precautions

Personnel should never work alone near high-voltage equipment. Tools and equipment containing metal parts should not be used within 4 feet of high-voltage circuits or electric wiring that have exposed surfaces. The handles of all metal tools, such as pliers and cutters, should be covered with rubber insulating tape. (The use of plastic or cambric sleeving or of friction tape alone for this purpose is prohibited.)

Before you touch a capacitor, short-circuit the terminals to make sure that the capacitor is completely discharged. Grounded shorting prods should be permanently attached to workbenches where electrical devices are regularly serviced.

Do not work on any type of electrical apparatus with wet hands or while you are wearing wet clothing. Do not wear loose or flapping clothing. The use of thin-soled shoes with metal plates or hobnails is prohibited. Wear safety shoes with nonconducting soles, if available. Do not wear flammable articles if at all possible.

When working on an electrical or electronic apparatus, you should first remove all rings, wristwatches, bracelets, and similar metal items. Make sure your clothing does not contain exposed zippers, metal buttons, or any type of metal fastener.

Warning signs and suitable guards should be provided to prevent personnel from coming into accidental contact with high voltages.

Low-Voltage Precautions

Most people never realize the dangers of low-voltage electric shock. These hazards are ever present; it is surprising how dangerous they can be. Defective hand tools and improper usage can be

corrected, but some hazards always exist. An awareness of their existence seems to be the answer. In general, beware of any voltage.

If any repair on a circuit card is required, you must first be certified as a microminiature repair technician in accordance with the Naval Aviation Maintenance Program (NAMP), OPNAVINST 4790.2 before attempting these repairs. If circuit card repair is required, normally it would be inducted into work center 690 at the Aircraft Intermediate Maintenance Department (AIMD).

The nonresident training course, *Airman*, NAVEDTRA 14014, addresses safety as it relates to naval aviation. The training manual, *Basic Military Requirements*, NAVEDTRA 12018, chapter 14, is a basic reference in the field of first aid. All naval personnel are required to possess knowledge of the principles of safety and first aid, and, for these purposes, these are excellent study references.

Q6-3. Which of the following types of SE are you most likely to find electrical wiring that is identified by color-coding?

- 1. The NC-8A Mobile Electric Power Plant*
- 2. The A/S32A-36A Crash Crane*
- 3. The MMG-1A Mobile Electric Power Plant*
- 4. The A/S32A-31A towing tractor*

Q6-4. What does the letter "N" signify in the wire number P15B2N?

- 1. The wire is a neutral wire*
- 2. The wire is at its termination point*
- 3. The wire has other connecting wires*
- 4. The wire has more than one function*

Q6-5. Which of the following is an advantage of using an ungrounded electrical system?

- 1. There are less wires used in the system*
- 2. An electrical grounding is not possible*
- 3. All wires are of a positive potential and troubleshooting is easier*
- 4. The negative wires are all connected to a central location on the unit*

Q6-6. When you perform work on electrical circuits, you should be insulated from ground by which of the following means?

- 1. A rubber mat*
- 2. Insulated gloves*
- 3. A protective apron*
- 4. Special protective clothing*

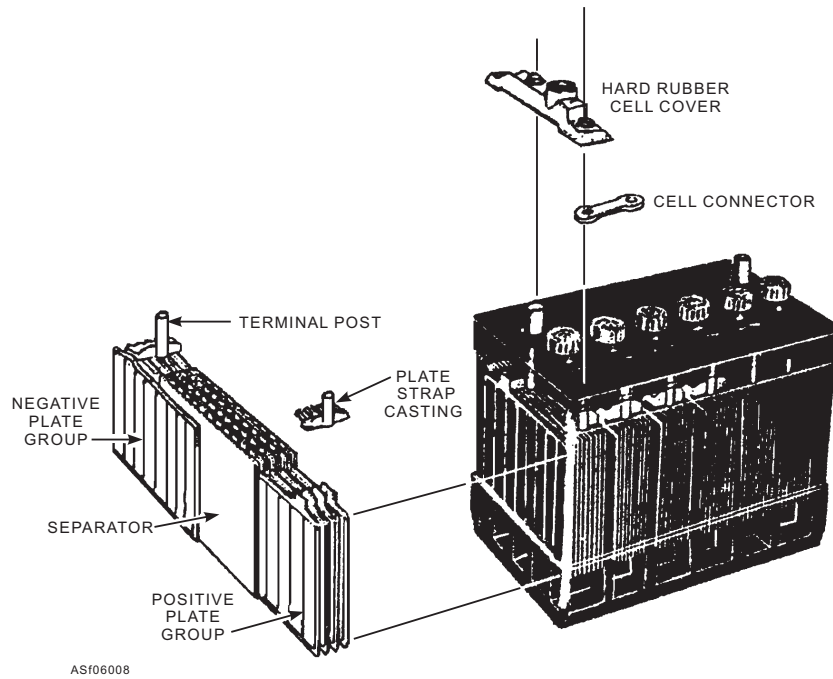

Figure 6-8.—Battery construction.

BATTERIES

LEARNING OBJECTIVES: Identify the types of SE batteries. Identify procedures for inspecting, testing, and servicing SE batteries. Identify the procedures for troubleshooting SE batteries. Identify the procedures for removing and replacing SE batteries.

The most commonly used batteries in support equipment are lead-acid batteries. The battery is used to start the engine, and it aids the generator in meeting the electrical system's power demands under low rpm and heavy load conditions. The battery can also supply a limited amount of power for a short time without operating the generator. Active materials within the battery react chemically to produce a flow of direct current whenever a load is connected. This current is produced by chemical reaction between the active materials of the lead plates and the sulfuric acid of the electrolyte.

CONSTRUCTION

A battery consists of a number of cells connected together. The number of cells depends on the voltage desired. Three cells connected in series make up what is commonly called a 6-volt battery. A 12-volt battery is made up of six cells connected in series, and a 24-volt battery has 12 cells connected in series. Most references on batteries state that each cell has a voltage of 2.0 volts. But each cell actually produces about 2.15 volts (no load) if a very accurate voltmeter is used and the cell is fully charged. When the cells are connected

in series to form a battery, it makes a noticeable difference in the battery voltage (6.45 volts for the 6-volt battery, 12.9 volts for the 12-volt battery, and 25.8 volts for the 24-volt battery). For purposes of discussion, however, we will refer to the cells as having a voltage of 2.0 volts.

Each cell contains positive lead plates and negative lead plates. As shown in figures 6-8 and 6-9, these

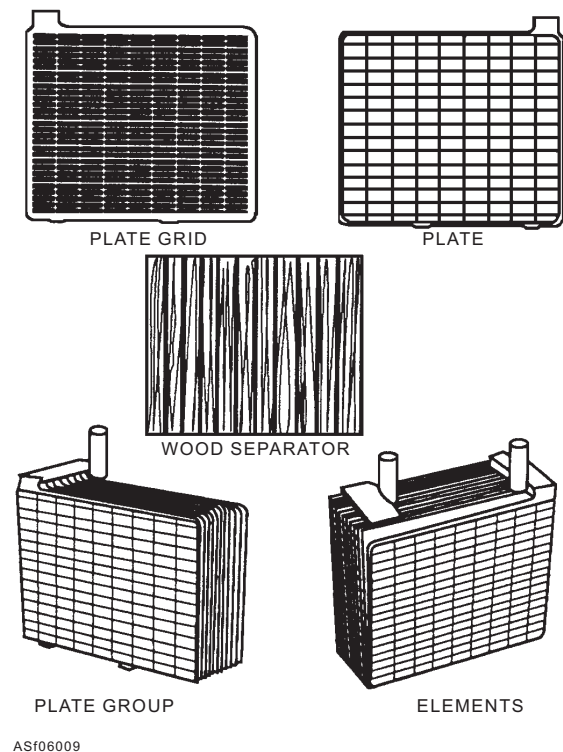

Figure 6-9.—Cell element construction.

plates are insulated from each other by suitable separators (wood, rubber, or glass) and are submerged in a sulfuric acid solution (electrolyte).

RATING

Lead-acid batteries are rated by their voltage and ampere-hour capacity. Standard automotive batteries have a 20-hour discharge rate, which is equal to the constant current in amperes that the battery can supply continuously for 20 hours before the voltage drops to a specified low-voltage level. For example, a battery rated by the manufacturer as 12-volts, 280-ampere-hours can discharge at a rate of 14 amperes for 20 hours before the voltage drops to its specified limiting voltage (280 ampere-hours ÷ 14 amperes = 20 hours). The voltage and ampere-hour rating of a battery is usually stamped on the battery case.

Table 6-1.—Specific Gravity of Lead-Acid Batteries

SPECIFIC GRAVITY	STATE OF CHARGE
1.265-1.290	Fully charged battery
1.235-1.260	3/4 charged
1.205-1.230	1/2 charged
1.170-1.200	1/4 charged
1.140-1.165	Barely operative
1.100-1.135	Completely discharged

As a lead-acid battery discharges, the sulfuric acid is absorbed by the plates and the electrolyte is gradually converted into water. This action provides a guide in determining the state of discharge of the lead-acid cell. All that is necessary to determine the state of charge of a battery is to determine the amount of sulfuric acid remaining in the electrolyte. This is easily done with a hydrometer. The hydrometer measures specific gravity, which is an accurate indication of the percentage of sulfuric acid remaining in the electrolyte. Table 6-1 lists specific gravity readings of lead-acid batteries in various states of charge.

In taking readings of specific gravity, the temperature must be taken into account. Specific gravity is a measure of the density of the electrolyte, and electrolyte becomes less dense as its temperature rises, and more dense as its temperature falls.

A hydrometer is marked (calibrated) to read specific gravity at a temperature of 80°F. Hydrometer readings taken on electrolyte that is warmer or colder than 80°F must be corrected to account for difference in

temperature. For every 10-degree difference in temperature above 80°F, you must add 0.004 to the specific gravity reading. For every 10-degree difference in temperature below 80°F, you must subtract 0.004. For example, suppose you get a hydrometer reading of 1.280 from a cell. Checking the temperature of the electrolyte with a thermometer, you get a reading of 60°F. This is a 20-degree difference from the normal temperature of 80°F. Therefore, you must subtract 0.008 from the hydrometer reading of 1.280 to get the true specific gravity of the battery, which is 1.272.

Note that a 20-degree difference in temperature did not make a significant difference in the specific gravity (less than 1 percent). From this you can see that it takes a relatively large difference in temperature to make a significant difference in specific gravity. Remember, however, that it is the temperature of the electrolyte that is important, not the temperature of the surrounding air. If the vehicle has been running, the battery is likely to be warmer than the surrounding air. Likewise, if the vehicle has not been running, the battery may be cooler than the surrounding air. In extremely hot or extremely cold conditions, readings may not be accurate even after correcting for differences in temperature.

A specific gravity correction chart, similar to the one shown in figure 6-10, is normally found on the

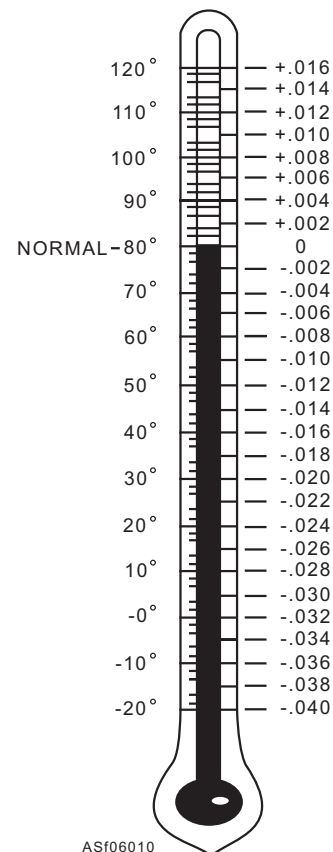

Figure 6-10.—Specific gravity temperature correction chart.

hydrometer, along with a thermometer and a table of correction values for making calculations.

CHARGING

When a discharged battery is brought to the battery shop, it should be recharged immediately. There are several methods for doing so, but the two principal methods are (1) constant potential charging and (2) constant current charging. With either method, you can charge a single battery or multiple batteries at the same time. In constant current charging, multiple batteries are connected in series. In constant potential charging, multiple batteries are connected in parallel. The constant potential method of charging is used most often because it is the simplest method, and because batteries do not require constant observation while being charged.

Constant Current Charging

In the constant current method, the battery is connected to a charging device that supplies a steady flow of dc current. A rheostat is built into the charger to adjust the current flow, and once the rheostat is set, the current remains constant. When using this method of charging a battery, check the battery frequently, particularly near the end of the charging period. When the battery is gassing freely and the specific gravity remains constant for 2 hours, the battery is fully charged.

NOTE: The term *gassing* refers to a condition that occurs while the battery is being charged. When a battery is being charged, a portion of the energy breaks down the water in the electrolyte. Hydrogen is released at the negative plates and oxygen at the positive plates. These gases bubble up through the electrolyte and collect in the air space at the top of the cell. If violent gassing occurs when the battery is first placed on charge, the charging rate is too high. If the rate is not too high, steady gassing develops as the charging proceeds, indicating that the battery is nearing a fully charged condition.

WARNING

A mixture of hydrogen and air can be dangerously explosive. No smoking, electric sparks, or open flames should be permitted near charging batteries.

The main disadvantage of constant current charging is that if the charging current is set too high, or if the battery is overcharged, the battery can overheat and possibly damage the plates.

Constant Potential (Voltage) Charging

Constant potential charging is done by a motor-generator set or a transformer-rectifier. With constant potential charging, the initial current flow to a discharged battery is high because of the difference between the battery voltage and the output voltage of the charger. As the state of charge of the battery increases, its voltage increases, reducing the difference in voltages between the charger and the battery. This decreasing voltage differential causes the charging current to gradually taper off to a very low value at the time the battery is fully charged.

Constant potential chargers are available in many designs and capacities—both stationary and portable. The one shown in figure 6-11 is portable. Constant potential chargers are common in support equipment work centers.

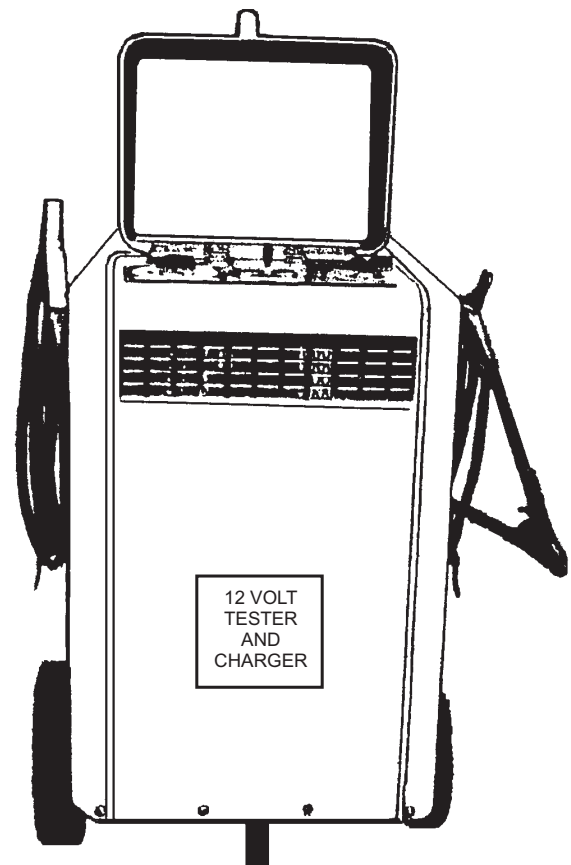

AS106011

Figure 6-11.—Portable constant potential battery charger.

Charging Procedures

Charging a battery is a simple task. You connect the charger cables to the proper terminals, turn the charger on, and set the timer. The charger will turn itself off at the proper time. Here is the procedure for charging a battery:

1. With the battery out of the vehicle, clean and inspect it thoroughly. Remove any corrosion present by using a solution of bicarbonate of soda and water. (Ensure that none of the solution enters the cells.) Check the case of the battery for cracks and breaks.

2. Remove the vent caps and inspect the battery internally. If the electrolyte level is low, add distilled water (or drinking water if distilled water is not available). Bring the level of the electrolyte to about three-eighths of an inch above the plates or to the level specified by the battery manufacturer. Place the vent caps in the cell openings, but do not tighten them down. (The vent caps keep electrolyte from spraying out of the cells during charging and keep foreign material out of the cells.)

3. Connect the battery to the charger. Ensure that the positive cable is connected to the positive terminal and the negative cable is connected to the negative terminal. Turn the charger on.

WARNING

Always connect the battery to the charger before turning on the charger, and disconnect the battery only after turning off the charger. This is to preclude the possibility of creating a spark, which could cause an explosion.

4. When the battery is fully charged, the charger will shut off. Remove the battery cables, tighten down the vent caps, and place the battery in storage or back in service.

Take frequent hydrometer and temperature readings of each cell and record them. The specific gravity can be expected to rise during the charge. If the specific gravity does not rise, the battery is bad and should be disposed of. Keep a constant watch for excessive gassing. This is especially important when you use the constant current method of charging. Be especially watchful at the very beginning of the charge when you use the constant voltage method. Reduce the charging current or voltage if excessive gassing takes place.

WARNING

Ensure that the charging area is well ventilated. Hydrogen gas released by batteries on charge is highly explosive. Do not allow smoking in the vicinity of batteries being charged.

SELF-DISCHARGE

Discharge takes place in batteries even when they are not in use. The rate of discharge varies with temperature and specific gravity of the electrolyte. Self-discharge changes the specific gravity of the electrolyte just as normal discharge does. Inactive, charged batteries should be stowed in a cool, dry place to reduce self-discharge. After a battery has been activated, the state of charge should be checked periodically (whether in use or not) and recharged when necessary. A battery is damaged if it is allowed to remain in a discharged condition. A good charge is especially important in cold weather to prevent freezing. A battery that is completely discharged freezes at about 18°F; a battery that has a specific gravity of 1.260 freezes at about -75°F.

PLACING IN SERVICE

New batteries may be received full of electrolyte and fully charged. In this case, all that is necessary to make them ready for service is to properly install them in the equipment. Most batteries, however, are received “dry and charged.”

Dry-charged batteries retain their state of full charge indefinitely so long as moisture is not allowed to enter the cells. Therefore, dry-charged batteries should be stowed in a cool, dry place. When moisture and air enter the cells, it causes the negative plates to oxidize and lose their charge. If dry-charged batteries are allowed to stay in this condition for a long period of time, damage results. Dry-charged batteries must be activated and recharged before you place them in service.

Activating a Dry-Charged Battery

To activate a dry-charged battery, remove the vent restrictors from the vent caps and remove the vent caps. Fill all the cells to the proper level with electrolyte that has a specific gravity of 1.275 or as specified by the battery manufacturer. Best results are obtained when the battery and the electrolyte are at a temperature between 60°F and 80°F, but in no case should the temperature of the electrolyte exceed 90°F. Some

gassing occurs while filling the battery, due to the release of carbon dioxide (a product of the drying process) or hydrogen sulfide (caused by the presence of free sulfur). These gases and odors are normal and are no cause for alarm.

Allow the battery to stand for at least 1 hour after filling it with electrolyte. If at the end of 1 hour the level of electrolyte has fallen, add more electrolyte to restore it, and replace the vent caps. If electrolyte is spilled on the battery, it should be removed. Use a solution of bicarbonate of soda and water, and be careful not to allow the solution to get into the cells. The exterior of the battery should then be flushed with fresh water.

Initial Charge

A new battery should be given an initial charge in accordance with the manufacturer's instructions. In the absence of instructions, the initial charge should be given at the rate of 1 ampere per positive plate per cell. Charging should continue until the specific gravity of all cells shows no increase over a period of 2 hours. If the temperature of the battery exceeds 100°F, stop the charge and allow the battery to cool.

Adjusting Specific Gravity

Usually, no adjustment of the specific gravity is necessary. However, if the specific gravity should exceed 1.300 in any cell, it should be reduced to some level between 1.275 and 1.300. You can reduce the specific gravity by removing a small amount of electrolyte with a hydrometer syringe and replacing it with distilled or drinking water.

Safe Handling of Electrolyte

Although a premixed electrolyte is usually available for servicing dry-charged batteries, you may be required to use concentrated sulfuric acid. If so, the sulfuric acid must be mixed with pure water to obtain the proper specific gravity for electrolyte.

Mixing electrolyte is dangerous. Concentrated sulfuric acid can burn clothing, and if it comes into contact with your skin or eyes, severe burns may result. You must observe the following safety precautions when working with concentrated sulfuric acid or electrolyte.

- Wear approved goggles, gloves, aprons, and boots.
- Use a lead-lined tank or a heavy plastic container to mix the electrolyte. Do not use materials

such as glass or earthenware because they may crack due to the heat generated during the mixing operation.

- Always pour acid into water slowly, stirring constantly but gently. Never pour water into concentrated acid. The resulting chemical reaction will generate heat so rapidly that the solution may boil and splash out of the container.

- Be alert for sprays and splashes when you open a container or during mixing. If acid spills, neutralize it with bicarbonate of soda or ammonia and flush with an abundance of water.

- If acid is spilled or splashed on any part of your body, neutralize it with a solution of bicarbonate of soda and water or ammonia and water. Immediately shower or flush the affected areas with large amounts of water. Should your eyes be affected, flush with an abundance of fresh water and seek medical attention immediately.

- Ensure that an adequate supply of first aid material is on hand at all times for neutralizing acid.

- Do not carry electrolyte in open-top containers, and ensure that glass containers are protected against breakage.

- Never allow containers of electrolyte to be placed near heating pipes or to stand in the sun for any length of time.

- Allow mixed electrolyte to cool to room temperature before adding it to battery cells. Do not add electrolyte to the battery if its temperature is above 90°F. Hot electrolyte can destroy the cell plates very quickly.

- After you fill the battery cells, allow the electrolyte to cool again. Remember that more heat is generated by its contact with the battery plates.

MAINTENANCE AND TESTING

Battery maintenance and testing should always begin with a thorough visual inspection. Look for signs of corrosion on or around the battery. Clean the top of the battery with a stiff bristle brush, being careful that particles brushed off do not get on your skin or clothing. Wipe the top of the battery with a cloth moistened with either ammonia or baking soda dissolved in water.

Remove the cables and inspect the terminal posts to see if they are deformed or broken. Clean the terminal posts, and clean the inside surfaces of the cable clamps before replacing them on the terminal posts. Inspect the

battery holder (cradle) and the battery hold-down device. Inspect the battery for a cracked or bulging case. Inspect the sealing compound on top of the battery for leaks or cracks.

Remove the vent cap from each cell and check the electrolyte level of the battery. Make sure the vents in the vent caps are free of any obstructions.

The state of charge and the ability of a battery to withstand loads must meet the manufacturer's specifications before you check any other part of an electrical system. The battery load test is recommended by most battery manufacturers. This test indicates how well the battery can perform under normal cranking load conditions. For example, take a 12-volt battery at 70°F. When a 300-amp load is applied for 15 seconds, the battery should produce 9.6 volts or better. If not, it should be charged or replaced.

For more information on servicing and maintenance of batteries, refer to *Naval Aircraft and Naval Aircraft Support Equipment Storage Batteries*, NAVAIR 17-15BAD-1.

Q6-7. How much voltage does each cell of a fully charged 12-volt battery produce?

1. 1.85 Vdc
2. 2.0 Vdc
3. 2.15 Vdc
4. 2.5 Vdc

Q6-8. What should the specific gravity reading be in a fully charged lead-acid battery?

1. 1.170 - 1.200
2. 1.205 - 1.230
3. 1.235 - 1.260
4. 1.265 - 1.290

Q6-9. Which of the following tools is used to measure the specific gravity of a lead acid battery?

1. A multimeter
2. An ammeter
3. A hydrometer
4. An electrometer

Q6-10. What type of gas is released from the negative plates of a lead acid battery when it is being charged?

1. Hydrogen
2. Oxygen
3. Nitrogen
4. Carbon monoxide

Q6-11. You can decrease the specific gravity of a lead-acid battery by performing which of the following functions?

1. By changing the number of negative plates in each cell
2. By removing a small amount of electrolyte and replacing with distilled water
3. By removing the vent caps to allow for evaporation of the electrolyte
4. By changing the number of positive plates in each cell

CHARGING SYSTEMS

LEARNING OBJECTIVES: Identify the components of SE electrical charging systems. Identify procedures for inspecting, checking, testing, and adjusting SE electrical charging system components. Identify procedures for troubleshooting SE electrical charging system components. Identify procedures for repairing, removing, and replacing SE electrical charging system components.

The electric generator is the heart of the automotive charging system. By using the principle of magnetic induction, the generator converts mechanical energy to electrical energy. The electrical energy produced by the generator recharges the battery and powers the entire electrical system while the engine is running. The output of the generator must be regulated to prevent system damage from overvoltage. A properly maintained charging system improves the reliability of support equipment.

Two types of generators are used in automotive systems: the direct current (dc) generator and the alternating current (ac) generator (alternator). The dc generator produces direct current to supply the electrical system's needs. It is controlled by a voltage and current regulator. The dc generator is limited in its output capability at lower engine speeds.

The alternator has the same function as the dc generator, but since the battery charging system requires dc, the ac output of the alternator must be converted to dc. The output of the alternator produces enough power to fulfill the system's needs at all engine speeds.

DIRECT CURRENT (DC) GENERATOR

The essential parts of a dc generator are the armature coil, the commutator with brushes, and a

stationary field coil. A simple dc generator is illustrated in figure 6-12. The commutator in basic generator is a ring split into two segments, which are insulated from each other. The two ends of the armature coil are connected to opposite commutator segments. The dial and pointer in figure 6-12 represent a galvanometer with zero in the middle of the scale. The pointer will move in either direction, measuring small amounts of current. Notice how the two brushes are mounted on opposite sides of the commutator to permit each brush to be in contact with a different segment as the armature turns.

In view A of figure 6-12, the armature is rotating clockwise; the black side of the armature coil is moving toward the North Pole, and the white side is moving toward the South Pole. At this very instant, both sides of the armature coil are parallel to the lines of flux. No lines are cut; therefore, no voltage or electromotive force (emf) is induced into the armature coil.

In view B, the armature coil has rotated 90 degrees. Both sides of the armature coil are cutting maximum lines of flux, so maximum voltage is induced into the armature coil, causing maximum current to flow as indicated by the galvanometer.

In views A and C (0 and 180 electrical degrees), no lines of flux are cut; therefore, no voltage is induced into the armature coil. There is no current flow, as indicated by the galvanometer. In views B and D, both sides of the armature coil are cutting maximum lines of flux, thereby inducing maximum voltage.

In studying figure 6-12, note carefully that when the black side of the armature coil is under the influence of the North Pole, the current flow is OUT. When the black side of the armature coil comes under the influence of the South Pole, shown in view D, the current flow is IN. As the armature rotates at certain positions (0 and 180 electrical degrees), the current flow will change direction within the armature coil. This changing direction of the current is referred to as alternating current (ac). When current was flowing OUT, the segment attached to the black side of the armature coil was making contact with the negative (-) brush, but when the current starts to flow IN, the segment switches to the positive (+) brush. This switching action of the commutator segments changes the ac within the armature coil to dc within the external circuit. Current always flows in the same direction through the galvanometer.

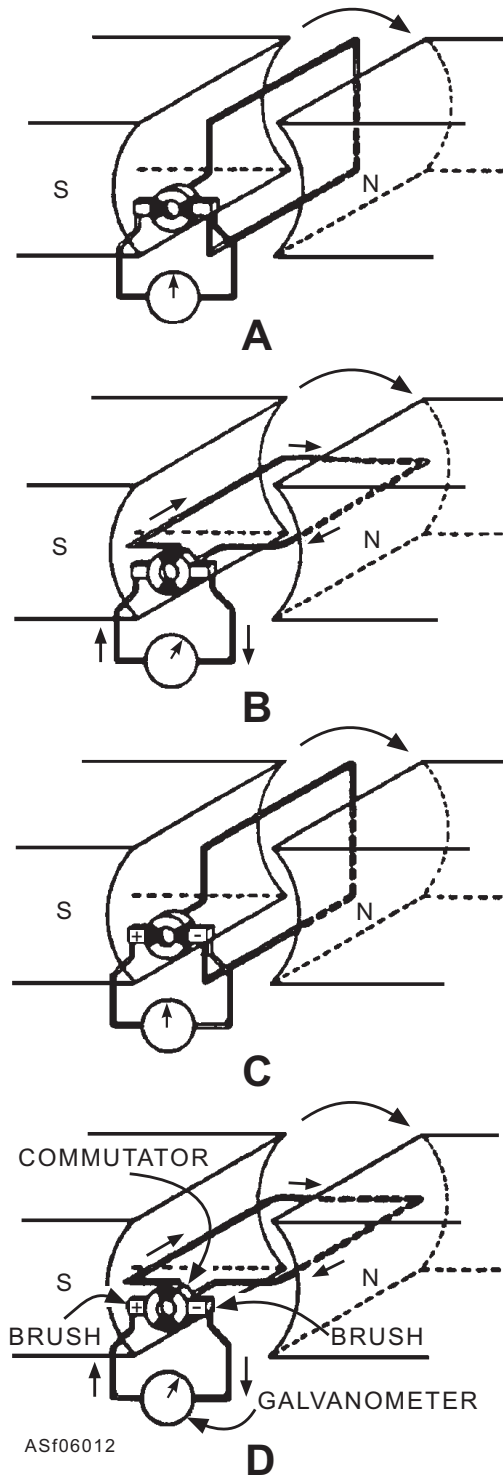

Figure 6-12.—Generating direct-current electrical energy.

The direction of current flow in the armature coil during rotation can be determined by using the left-hand rule for generators. The left-hand rule, illus-

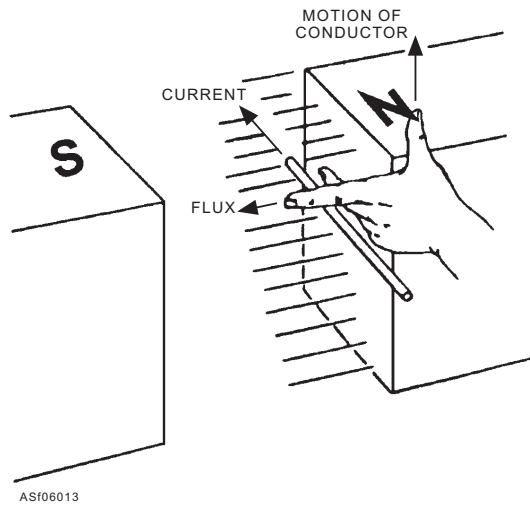

Figure 6-13.—Left-hand rule for generators.

trated in figure 6-13, is applied as follows: Extended the left hand so the THUMB points in the direction of conductor movement (side of armature coil), and the FOREFINGER points in the direction of magnetic flux (north to south). By pointing the MIDDLE FINGER 90 degrees from the forefinger, it will point in the direction of current flow within the conductor.

The simple generator circuit shown earlier in figure 6-12 was for explanation purposes only. The output of that generator would be a very low dc voltage. In reality, a generator must have several loops or turns of wire in each armature coil for sufficient voltage to be induced into the coil (fig. 6-14). Likewise, the armature must have several coils distributed evenly around the armature core. The coils or armature windings are

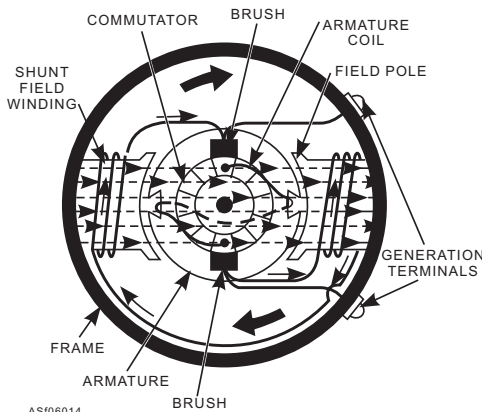
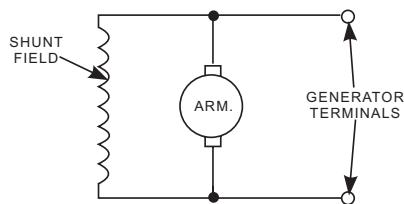

Figure 6-14.—A shunt-wound generator.

connected to each other and to the commutator segments in such a way that the voltage impulses overlap and produce a steady output voltage. This may be compared to the overlapping of power impulses in an automobile engine.

The armature core (fig. 6-14) on which the armature windings or coils are mounted is made of laminated soft iron. The core is laminated to reduce eddy currents, and is made of soft iron for permeability.

The purpose of the field windings (field core) (fig. 6-14) is to increase the strength of the magnetic field so more current will be induced in the armature windings as the armature rotates. In most generators the field windings are connected in parallel with the armature winding (that is, across the brushes); this arrangement is called a shunt-field winding. Figure 6-14 represents a shunt-wound generator with only one armature coil. About 8 to 12 percent of the total current generated by the armature is shunted through the field coils for producing the magnetic field under normal load conditions.

Dc generators (figs. 6-15 and 6-16) consist of four main subassemblies or components: the frame and field assembly, the armature, the commutator end head assembly, and the drive end head. The frame and field assembly consists of the pole shoe, the field coils, and the frame, which supports the remaining main components of the generator. The field coils supply the magnetic field, which is necessary to generate electricity. The pole shoes concentrate the magnetic lines of flux of the field coils and hold the field coils in place. The armature consists of a laminated iron core fixed to a shaft and the copper windings, which are wound in slots in the core. The ends of these windings are connected to the commutator, which consists of a number of copper segments that are insulated from each other and from the core and shaft.

The commutator end head is a cast-iron plate that closes one end of the frame and supports one of the armature bearings. The commutator end head also supports the brush holders and brushes that contact the commutator to carry the electricity from the rotating armature. The drive end head closes the drive end of the frame and also supports a bearing for the armature shaft.

Dc generators vary in design because of the different electrical and mechanical characteristics desired for particular installations. The size, type of mounting, type of drive, or the voltage and current output differ, but all dc generators include the four components just described.

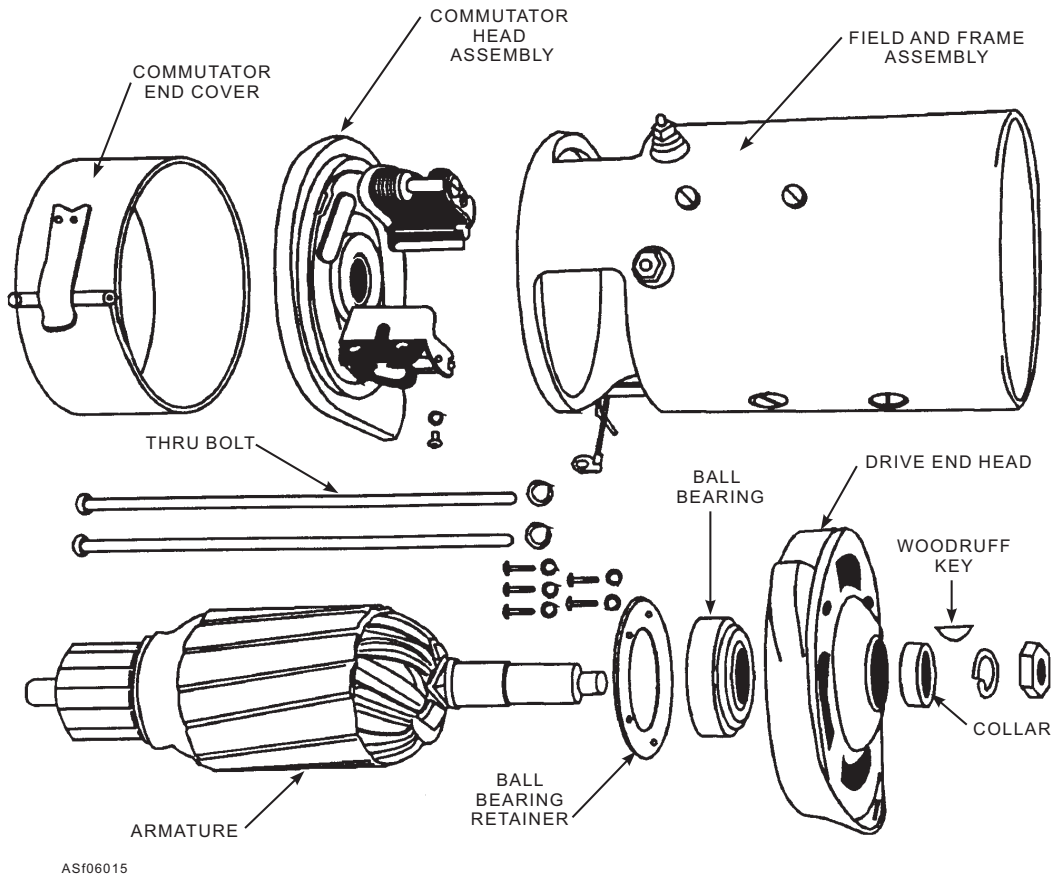

ASF06015

Figure 6-15.—Two-brush, dc generator.

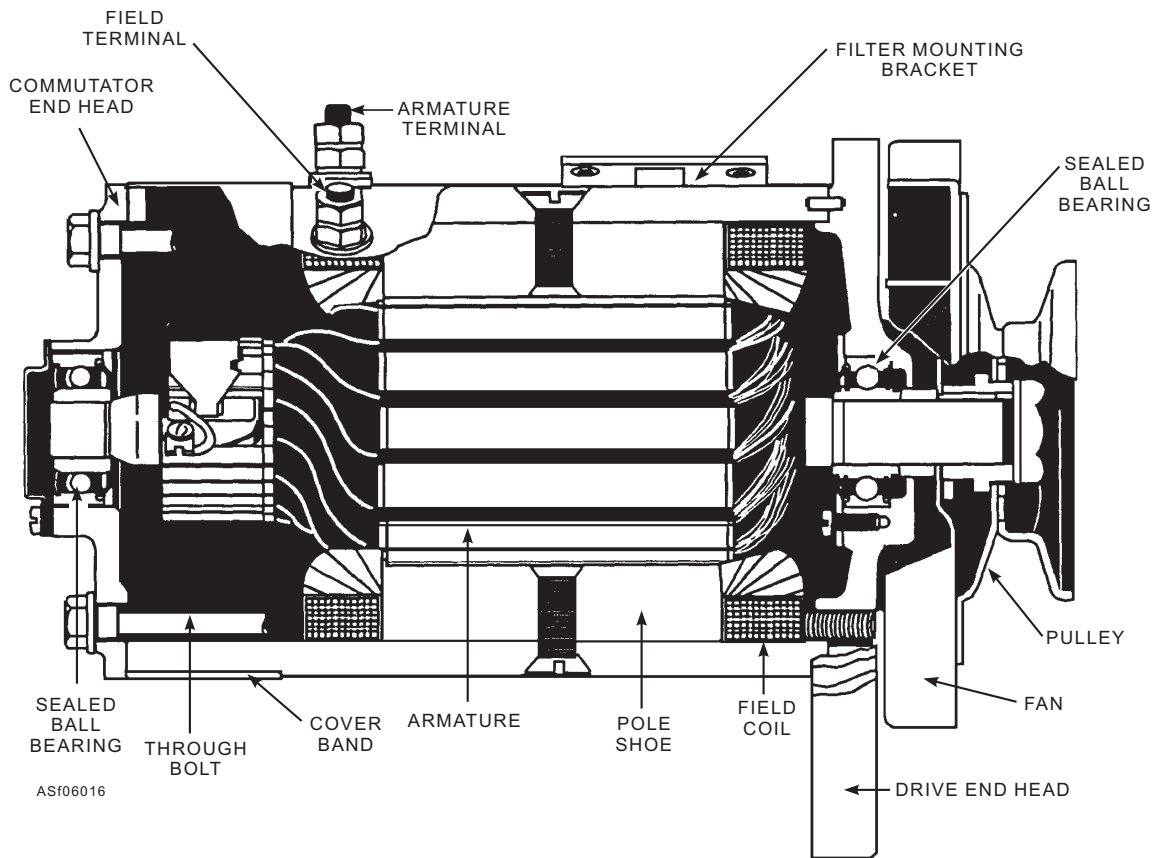

ASF06016

Figure 6-16.—Sectional view of dc generator.

Automotive generators are disassembled only when major repairs are to be made. Other than cleaning commutators and replacing worn brushes during periodic maintenance checks, automotive generators need few major repairs during normal service life. However, if neglected, generators will develop troubles that cannot be remedied in the field. In this case, the generator must be removed from the vehicle and taken to the shop for repairs.

ALTERNATING CURRENT (AC) GENERATOR (ALTERNATOR)

The output requirements of automotive electrical generators have increased considerably in recent years because of the growing popularity of power-consuming electrical accessories, such as heavy-duty heaters and air-conditioners.

A conventional dc generator that would produce the required amount of electricity at both a high- and low-speed range would be so large that its practical application would be limited. An ac generator (alternator), on the other hand, can produce enough power to fulfill almost any need over a speed range varying from idle to top engine speed.

Because of the small size of the alternator, it can be adapted to almost any piece of equipment. It is constructed to withstand vibrations and high speeds that are encountered in normal service.

The alternator and the conventional dc generator operate on the same theory. The field produces lines of force that are cut by the loops of the armature winding, inducing alternating current. Basically, the two generators are composed of the same functional parts—a rotor, a stator, and a device for extracting direct current from alternating current.

In the dc generator, the stator is the field, the rotor is the armature, and the commutator and brush assemblies are the devices for extracting direct current from alternating current.

The components of the alternator are the rotor, the stator, the brush assembly, and the rectifier. The rotor is a rotating magnetic field serving the same function as the fixed field in a dc generator, and the rotor current is provided through brushes and a slip ring assembly. The rotating field induces a current flow in the stator, which has three fixed coils of wire, physically located 120 degrees apart and connected to produce a three-phase output. The output of the stator is wired directly to the rectifier, which consists of six diodes mounted inside the alternator. The rectifier is full-wave, converting the ac output of the stator to direct current.

This arrangement has many advantages over a dc generator armature. All the current generated in a dc armature must be transferred to the system through brushes. Where the output is high, the brushes have to be very large to handle the power. In the alternator, this problem is eliminated because the stator windings are stationary. Only low voltage field current passes through the alternator's brushes. Since the stator windings are stationary, they are not affected by centrifugal force as are the loops in the armature of a dc generator.

The rotor consists of four parts—a coil, a core, and two rotor halves or spiders. The rotor is assembled by placing the coil on the core and then fitting the rotor halves around them. These are assembled on a shaft, and the coil leads are connected to slip rings.

Because of the rugged construction of the rotor halves, this unit can be rotated at very high speeds without damage. The limiting factor is the rpm rating of the bearings that hold the shaft in the housing.

A basic alternator (fig. 6-17) consists of one winding or loop in the stator and a single pair of poles in the rotor. When the rotor of this machine is turned through 360 degrees, it induces a single cycle of alternating current. If a rotor with six pairs of poles were put in the basic alternator (fig. 6-18), six cycles of alternating current would be generated every time the rotor made one complete revolution.

If two more windings were added to the stator (fig. 6-19), six cycles of alternating current would be generated in each loop for every revolution of the rotor. This type of machine is called a three-phase alternator.

The alternator is self-limiting in respect to the output current, which is about 130 percent of its rating. It is limited due to the impedance (caused by inductive

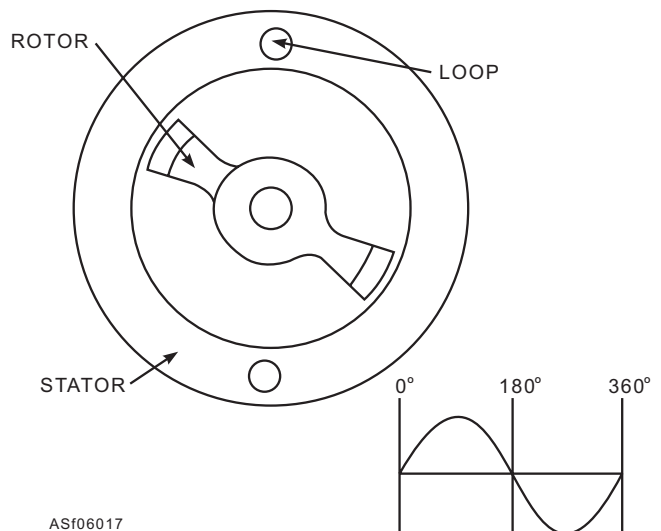

Figure 6-17.—A simple alternator.

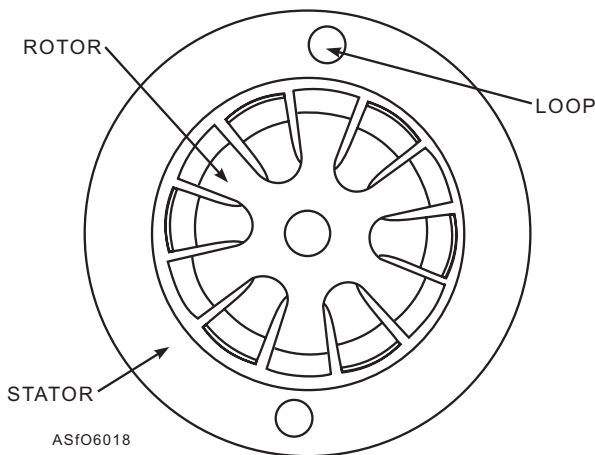

Figure 6-18.—A basic alternator with six pairs of poles in the rotor.

reactance) of the stator windings. The formula for inductive reactance is $X_L = 2\pi fL$, where f = frequency and L = inductance. As the speed of the rotor increases, the frequency of the output also increases. And, as the frequency increases, so does the impedance of the stator coils. Eventually, the stator impedance increases sufficiently to limit the output current.

Rectifiers

The battery and other electrical accessories in the automotive electrical system operate on current that flows in one direction only (direct current). For this reason it is necessary to change the alternating current to direct current. This function is performed by rectifiers. The type of rectifier used in automotive alternators is shown in figure 6-20—the semiconductor diode. The silicon diode is the type most commonly used. (Refer to NEETS, Module 7, for a more in-depth explanation of diodes and rectifiers.)

Alternators have semiconductor rectifiers (diodes) mounted within the alternator. The main advantages of diodes over the previously used metallic rectifiers are that they have a higher current-carrying capacity, are of more rugged construction, and are small in size.

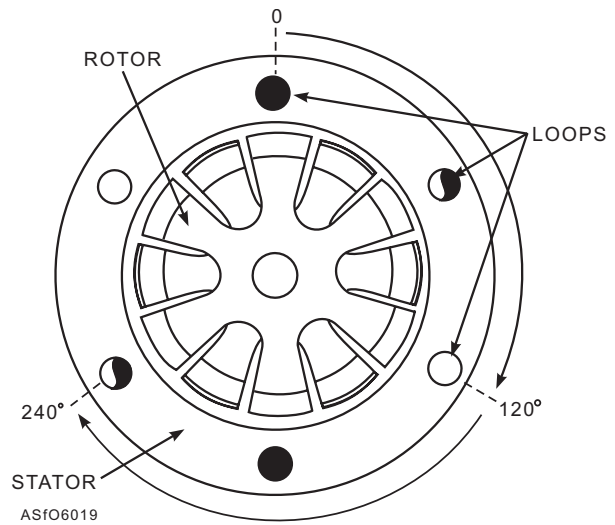

Figure 6-19.—A three-phase alternator.

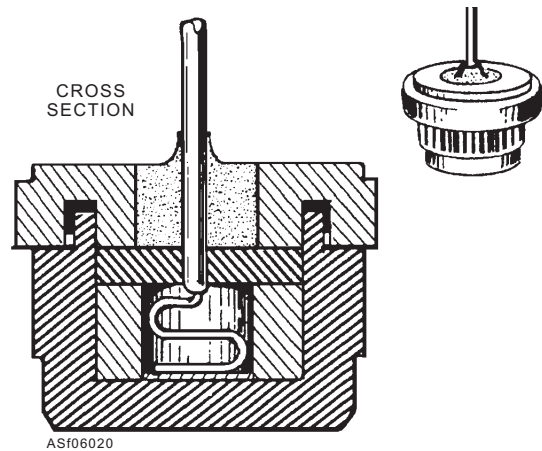

Figure 6-20.—A semiconductor (diode) rectifier.

Identification of diode polarity varies greatly with the alternator model and manufacturer. Some are plainly marked with a + or - sign, and some are marked with red and black lettering. Others are threaded to indicate polarity—left for positive, right for negative.

Automotive alternators use six diodes to provide full-wave rectification of the alternator's three-phase output, providing dc current at the output terminal. (See fig. 6-21.) These six diodes (three positive and three

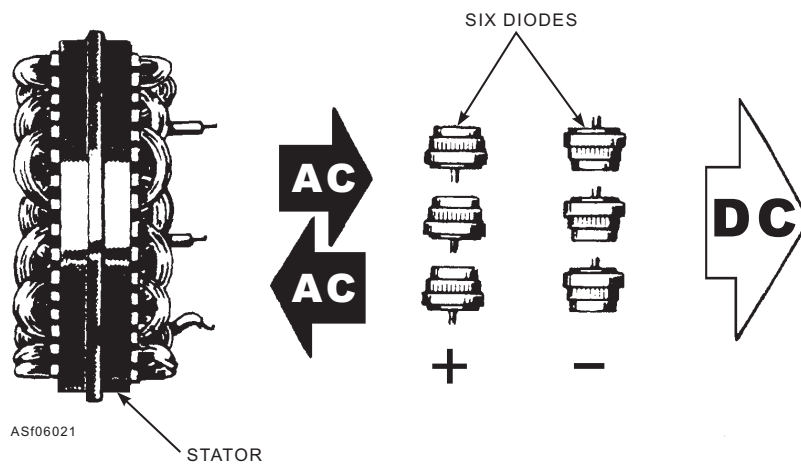

Figure 6-21.—Function of the alternator diode.

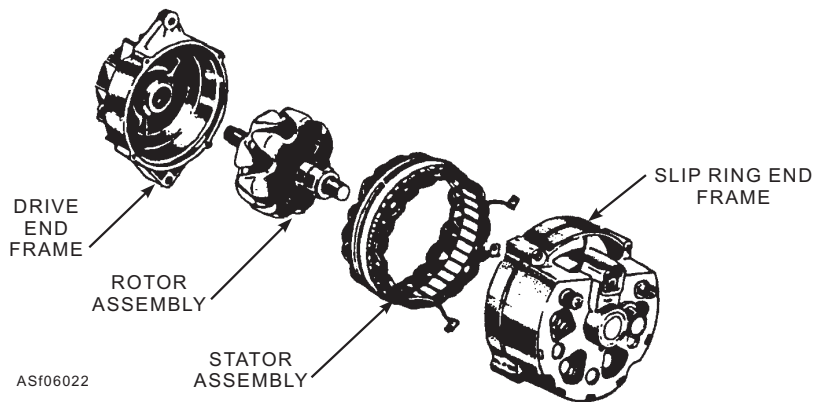

Figure 6-22.—A disassembled alternator.

negative) are mounted internally—three negative on the slip ring end frame and three positive on the heat sink mounted on the slip ring and frame.

AC Generator Subassemblies

The ac generator (alternator), shown in figures 6-22 and 6-23, consists of four main subassemblies or components—the slip ring end frame assembly, the stator assembly, the rotor assembly, and the drive end frame. The slip ring end frame assembly (fig. 6-24) holds the rear rotor shaft bearing, the diode rectifiers and heat sink, the brushes and brush holder, and a capacitor to limit voltage surges across the diodes. The stator assembly has a laminated iron frame, and the

windings for the three phases are wound through and around it. The rotor assembly (fig. 6-25) is composed of the slip rings, the field windings, the rotor shaft, and two rotor segments. The drive end frame mounts the front rotor shaft bearing and provides lugs for mounting the alternator to an engine.

Disassembling an AC Generator

The first step in disassembling an ac generator is to scribe a line across the area where the drive end frame, stator assembly, and slip ring end frame join. This will aid you in replacing these components in their original position during reassembly.

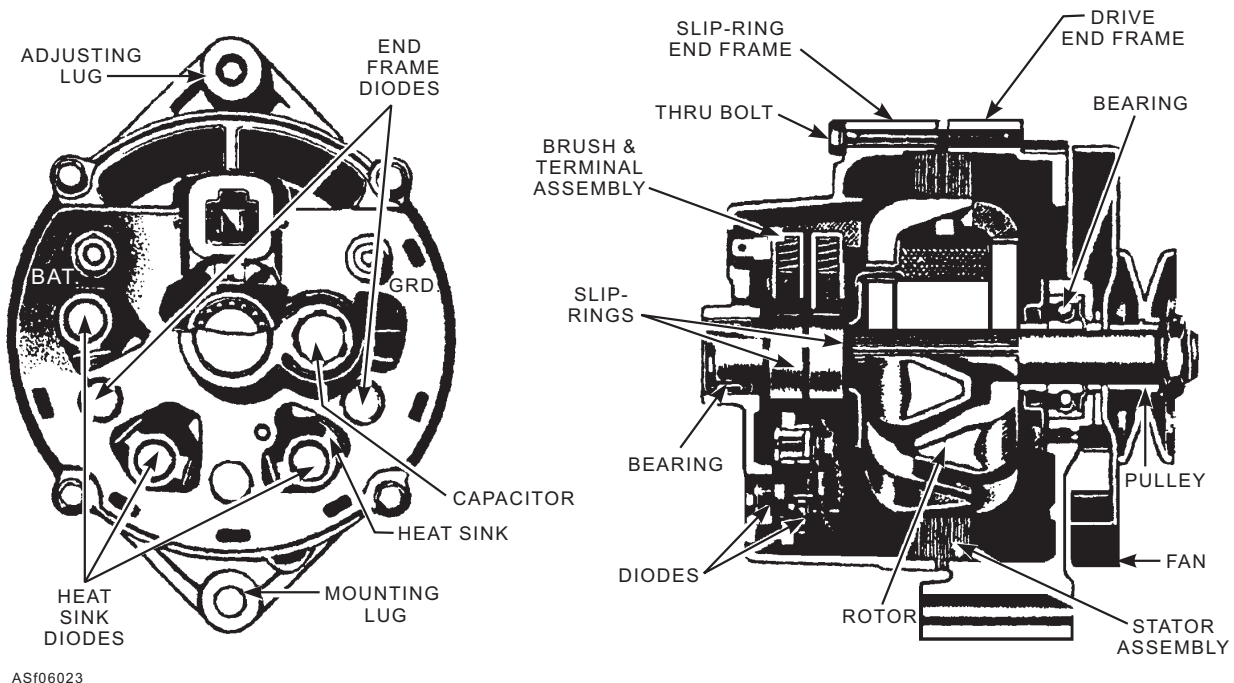

Figure 6-23.—An alternator.

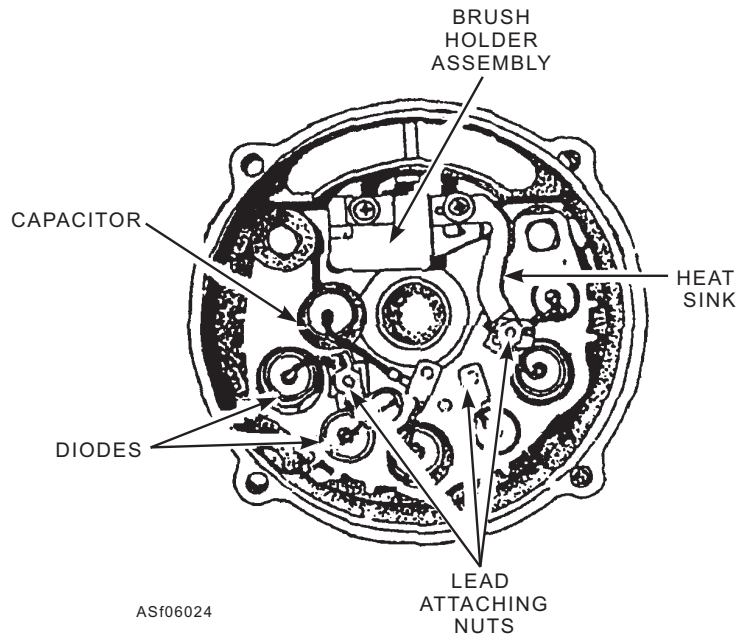

Figure 6-24.—View of an ac generator slip ring end frame assembly.

Remove the bolts and separate the drive end frame and rotor assembly from the stator assembly by inserting a flat tool in the stator frame slot. The separation is made between the stator frame and the drive end frame because the stator windings are connected to the diodes in the slip ring end frame assembly. Once the drive end frame and the rotor assembly are removed, tape the slip ring end frame assembly rotor shaft bearing to prevent entry of dirt, and also tape the bearing area of the rotor shaft on the slip ring end. Place the rotor assembly in a soft-jawed vise and tighten just enough to allow removal of the drive pulley retaining nut. Be careful not to damage the

pulley or the rotor shaft. Remove the pulley, fan, and collar. Then separate the drive end frame from the rotor assembly. Remove the three stator lead attaching nuts from the diodes, and remove the stator assembly from the slip ring end frame assembly.

No further disassembly is required to make electrical tests on the four major subassemblies and their components.

Testing the Rotor

The rotor is tested for grounds, shorts, and opens. To test for grounds, connect a test lamp or an ohmmeter

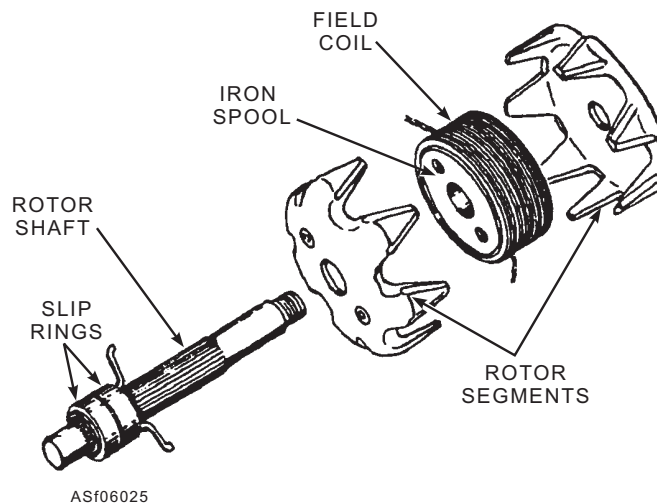

Figure 6-25.—Exploded view of an alternator rotor.

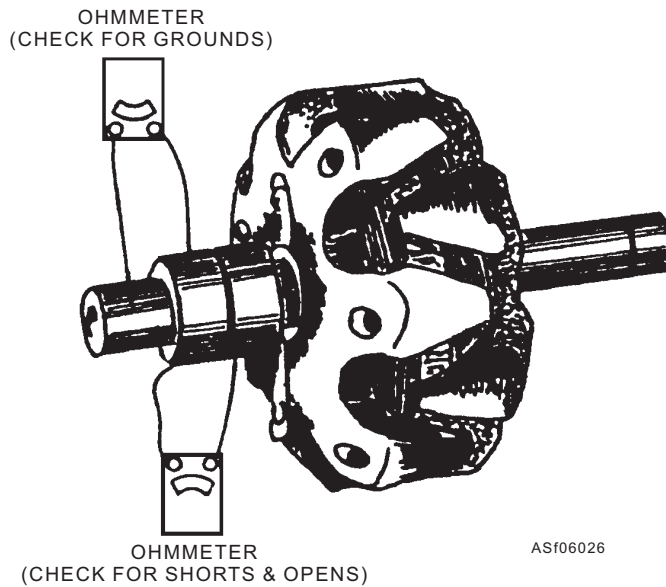

Figure 6-26.—Testing the rotor for grounds, shorts, and opens.

from either slip ring to the rotor shaft (fig. 6-26). A low ohmmeter reading or lighting of the test lamp indicates that the rotor winding is grounded and the rotor needs to be replaced. To test the rotor winding for opens and shorts, connect an ohmmeter or a test lamp to both slip rings, as shown in figure 6-26. An ohmmeter reading below the specified resistance value indicates a short, whereas a reading above the specified value indicates an open. If the test lamp does not light when connected to both slip rings, the winding is open, and the rotor needs to be replaced.

Testing the Stator

The stator windings are tested for opens and grounds after the stator has been removed from the slip ring end frame assembly. If the ohmmeter reading is low or if the test lamp lights when connected between each pair of stator leads (fig. 6-27), the stator winding is electrically good. A high ohmmeter reading or failure of the test lamp to light when connected between any two of the stator leads indicates an open winding. A low ohmmeter reading or lighting of the test lamp when

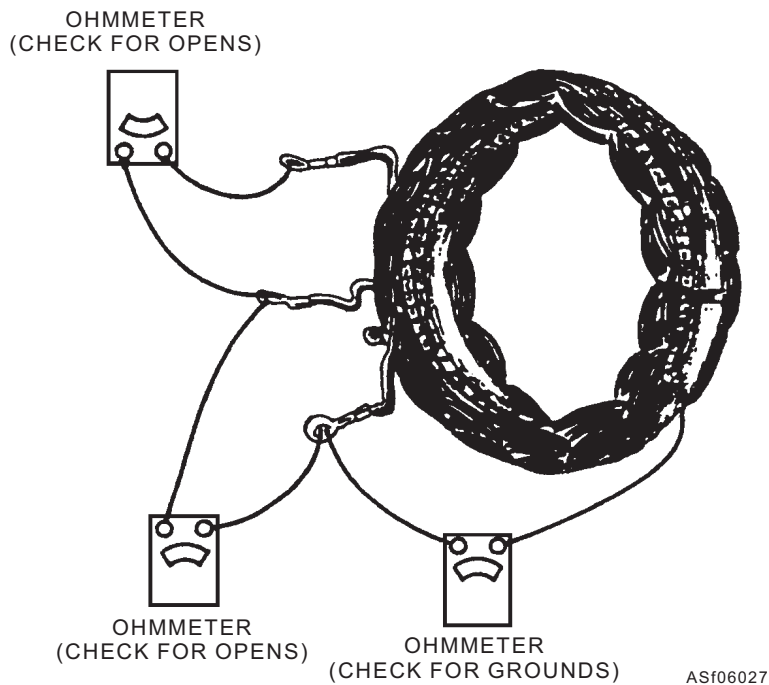

Figure 6-27.—Testing the stator for opens and grounds.

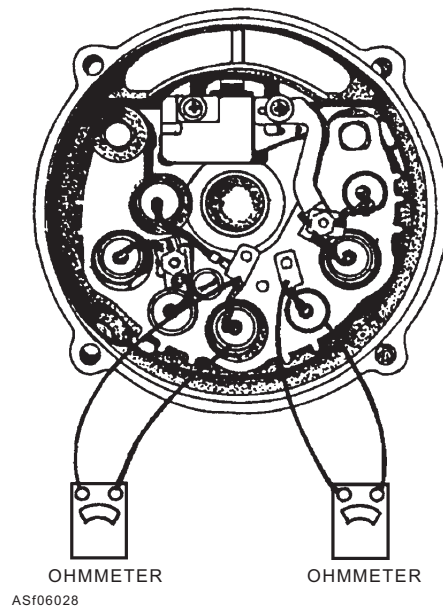

Figure 6-28.—Testing diodes with an ohmmeter.

connected between any of the stator leads and the stator frame indicates a grounded winding. It is not practical to test the stator windings for shorts because of the very low resistance of the windings. However, if all other test results are within specifications and the generator will not produce rated output, shorted stator windings are indicated.

Testing the Diodes

With the stator windings disconnected, each diode may be tested with an ohmmeter by connecting one test lead to the diode lead and the other to the diode case, as shown in figure 6-28. Note the reading. Then, reverse

the ohmmeter leads to the diode, and again note the reading. If both readings are very low or very high, the diode is defective. A good diode will give one low and one very high reading. An alternate method of testing each diode is to use a test lamp with a battery having a voltage no greater than that of the system being tested.

Connect one of the test leads to the diode lead, and the other test lead to the diode case, as shown in figure 6-29. Then, reverse the lead connections. If the lamp lights in both checks, the diode is defective. If the lamp fails to light in either direction, the diode is defective. When you are checking a good diode, the lamp will light in only one direction.

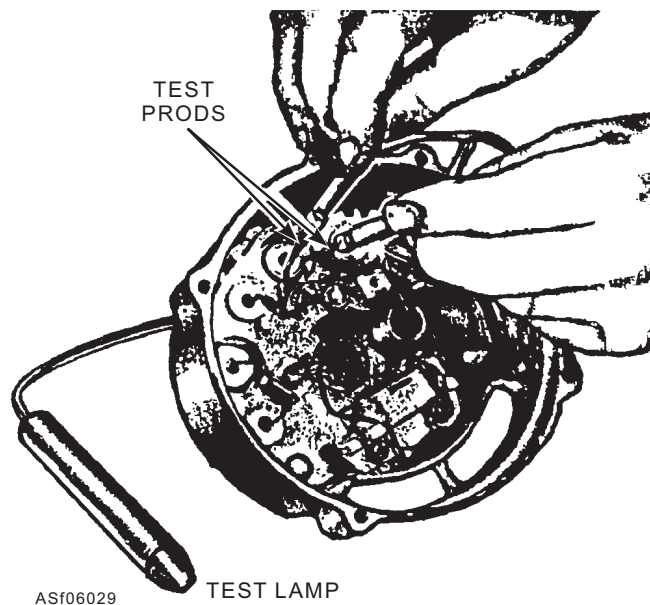

Figure 6-29.—Testing diodes with a test lamp.

Replacing the Diodes

Use the manufacture's specified tools, if available, and a press or vise to remove and install the diodes, as shown in figures 6-30 and 6-31. If the manufacture's tools are not available, suitable substitutes may be used, but you must exercise particular care to prevent damage to the diodes or the slip ring end frame assembly.

CAUTION

Do not strike any of the diodes while you are removing or installing them. The shock may cause damage to the diode being removed or installed as well as to others already installed.

Once you have replaced all the defective diodes, test them (as previously described) before reassembling the generator. This is to ensure they are still in satisfactory condition.

Slip Ring Servicing

If the slip rings are dirty, you may clean and finish them with 400-grit polishing paper or crocus cloth. Spin the rotor, in a lathe if possible, and hold the polishing material against the slip rings until they are clean.

CAUTION

The rotor must be rotated so the slip rings are cleaned evenly. Cleaning by hand without spinning the rotor will result in flat spots that will cause excessive brush wear and noise. Slip rings that are out-of-round, or very rough, must be turned in a lathe. Inspect the brushes for excessive wear. Replace them if they are worn to less than half the original length.

Bearing Replacement and Lubrication

Remove the bearing retainer plate and oil seal assembly and, using suitable adapters, press the bearing from the drive end frame. Clean the bearing with an approved cleaning solvent, and dry it with low-pressure compressed air. Cleaning solvents are toxic and should be used only in well-ventilated areas.

Inspect the bearing. If it is in satisfactory condition, it may be reused. However, if while you are turning the bearing by hand, you find rough spots or excessively worn balls, it must be replaced. If the bearing is to be reused, fill it one-quarter full with special grade ball bearing grease and reinstall it in the drive end frame. If the bearing retainer plate's felt oil seal is hardened or excessively worn, the retainer plate and seal assembly should be replaced.

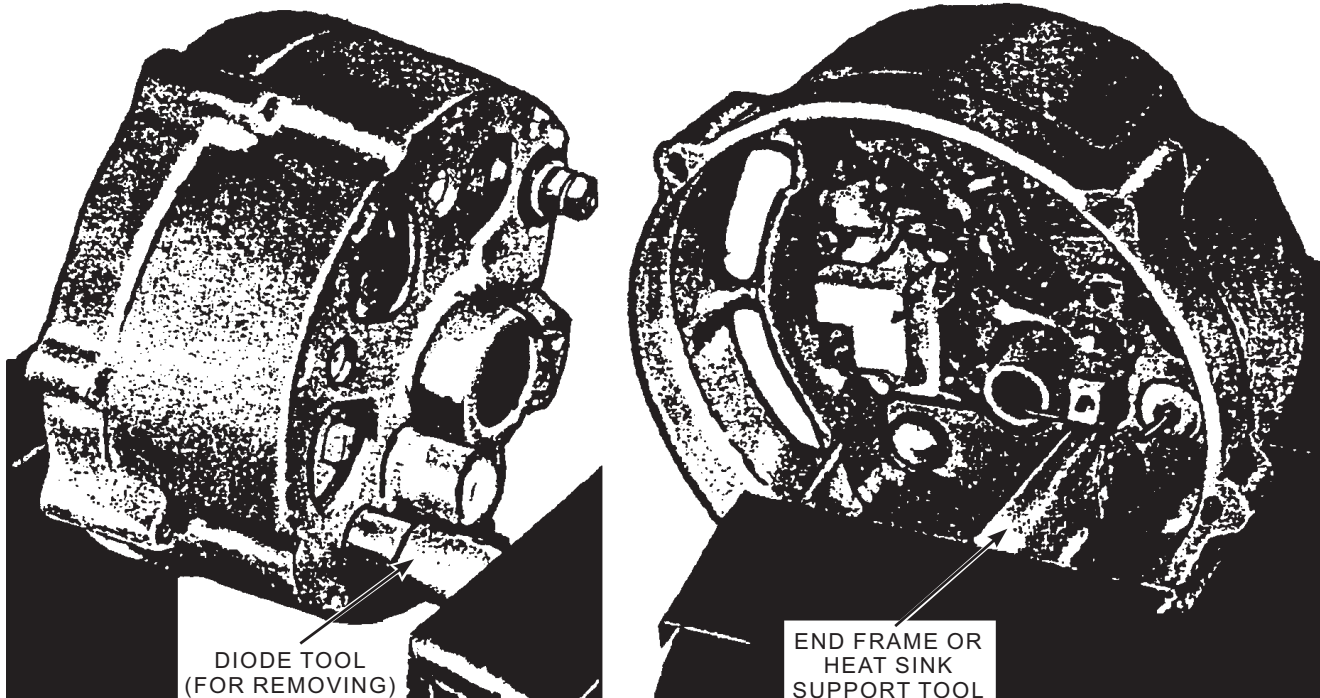

ASF06030

Figure 6-30.—Removing diodes.

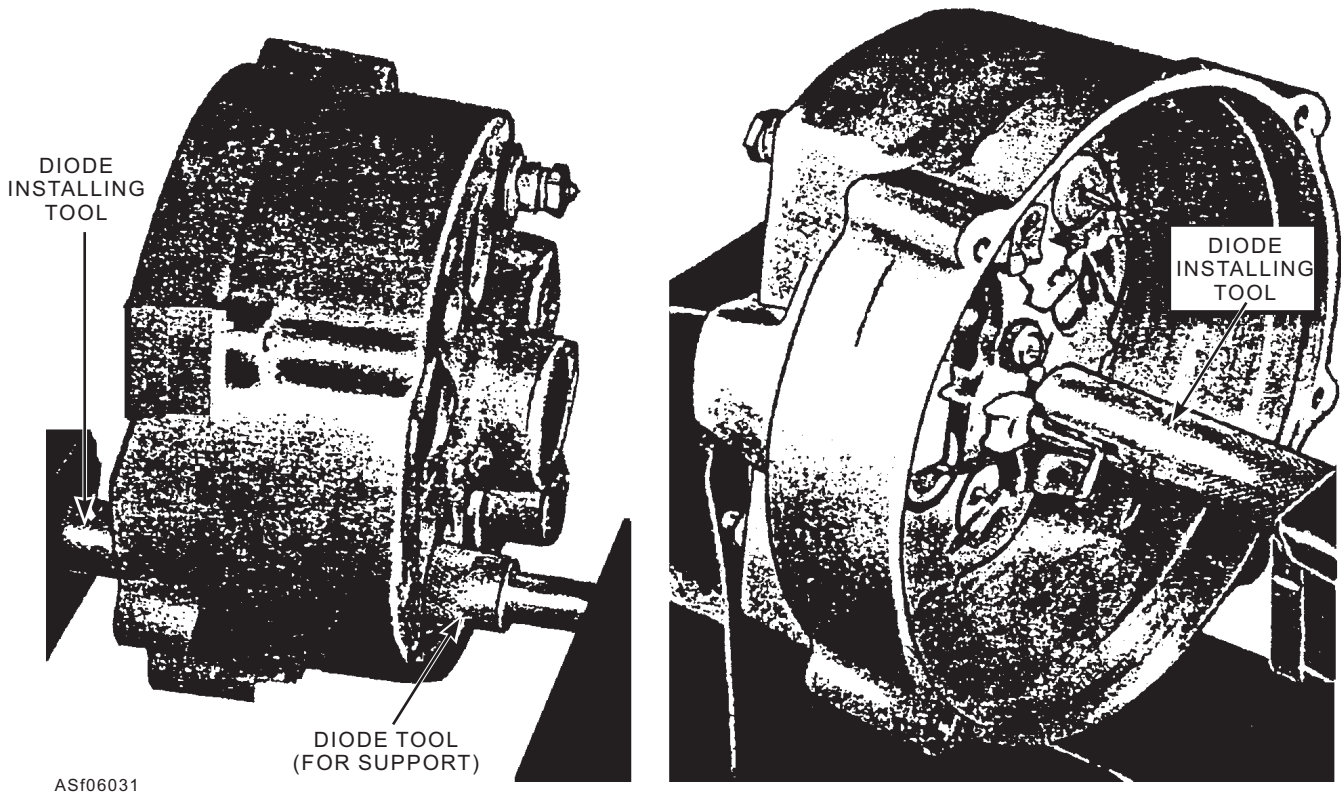

Figure 6-31.—Installing diodes.

The bearing in the slip ring end frame assembly must be replaced if its supply of grease is exhausted. You should not attempt to relubricate and reuse a bearing in this condition.

To replace a bearing, press the old one out of the slip ring end frame by using a tube or collar the same diameter as the outside of the bearing. Press from the outside while you support the inside with a hollow cylinder to prevent distortion and breakage of the slip ring end frame. Install the new bearing by placing a flat plate over the bearing and pressing it in from the outside until the bearing is flush with the outside of the slip ring end frame. Support the inside with a hollow cylinder to prevent distortion and breakage of the slip ring end frame.

Reassembly

Reassembly is essentially the reverse of the disassembly procedures given in the preceding section. However, there are a few points to remember.

- When you assemble the drive belt pulley to the rotor shaft, secure the rotor in a vise only tight enough to tighten the nut to the torque specified by the manufacturer.
- Ensure that the bearing areas of the rotor shaft are free of dirt or grime.

- When you install brushes, exercise care to prevent chipping or other damage to them.
- It is not necessary to polarize the alternator system.
- When you solder, use 60/40 rosin core. NEVER use acid core; it is corrosive and can lead to further damage.
- Brushes and brush springs must be set in the brush holder before assembly. They can be held in position by a retaining pin or a stiff wire inserted through the hole provided in the slip ring end plate. Be sure to remove the pin after assembly.

Q6-12. At what specific value will an alternator limit its current output?

1. At 100% of its rated output
2. At 110% of its rated output
3. At 125% of its rated output
4. At 130% of its rated output

Q6-13. How many diodes does an automotive alternator have?

1. Three
2. Four
3. Five
4. Six

Q6-14. When testing the diodes in an automotive alternator, which of the following multimeter reading, if any, is considered to be a good diode?

1. A high resistance reading in both directions
2. A high resistance reading in one direction and a low resistance reading in the other direction
3. A low resistance reading in both directions
4. None of the above

VOLTAGE REGULATION

LEARNING OBJECTIVES: Identify the components of SE voltage regulating systems. Identify procedures for inspecting, checking, testing, and adjusting SE voltage regulating system components. Identify procedures for troubleshooting SE voltage regulating system components. Identify procedures for repairing, removing, and replacing SE voltage regulating system components.

Regulation of a generator's output is necessary to prevent damage to the generator and the systems it supplies. Without regulation, the voltage achievable is limited only by the rpm of the driving engine.

Several types of regulators are in use in today's automotive systems. The basic regulators covered in this course are the three-unit vibrating-contact, the two-unit vibrating-contact, the two-unit transistorized, and the fully transistorized unit. Discussion of these units is intended only to familiarize you with their

operation. This manual is not to be used in lieu of the manufacturers' manuals.

THREE-UNIT VIBRATING-CONTACT DC REGULATOR

The vibrating-contact regulator (fig. 6-32) is the type most commonly used on dc generator-equipped vehicles. The regulator consists of a reverse current relay, a voltage regulator, a current regulator, and two resistors.

There are two types of circuits in use for systems using dc generators and vibrating-contact regulators. One is referred to as a type *A* or standard-duty circuit in which the generator field circuit is connected to the armature terminal inside the generator and is grounded externally through the regulator contacts. The other is referred to as a type *B* or heavy-duty circuit in which the generator field circuit is connected to the armature terminal inside the regulator and is grounded inside the generator.

Generally, testing either type is done in the same way, with these exceptions: the way the field control is connected for the reverse current relay check, and the way the generator is polarized.

The regulator shown in figure 6-33 controls voltage and current by automatically cutting resistance in or out of the field circuit of the generator. Varying the amount of resistance in the field circuit changes the amount of current passing through the generator fields. This, in turn, changes the strength of the magnetic field produced in the generator. Thus, generator output is regulated by controlling field current.

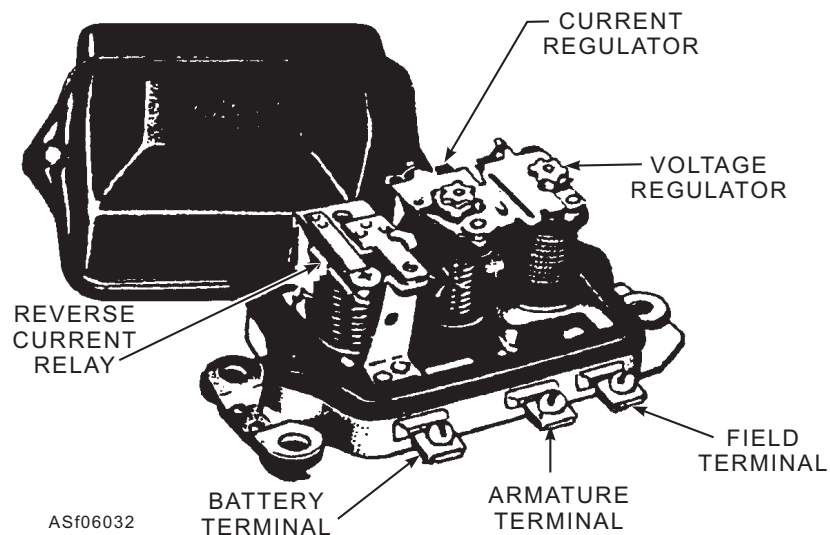

Figure 6-32.—Three-unit, vibrating contact, dc regulator.

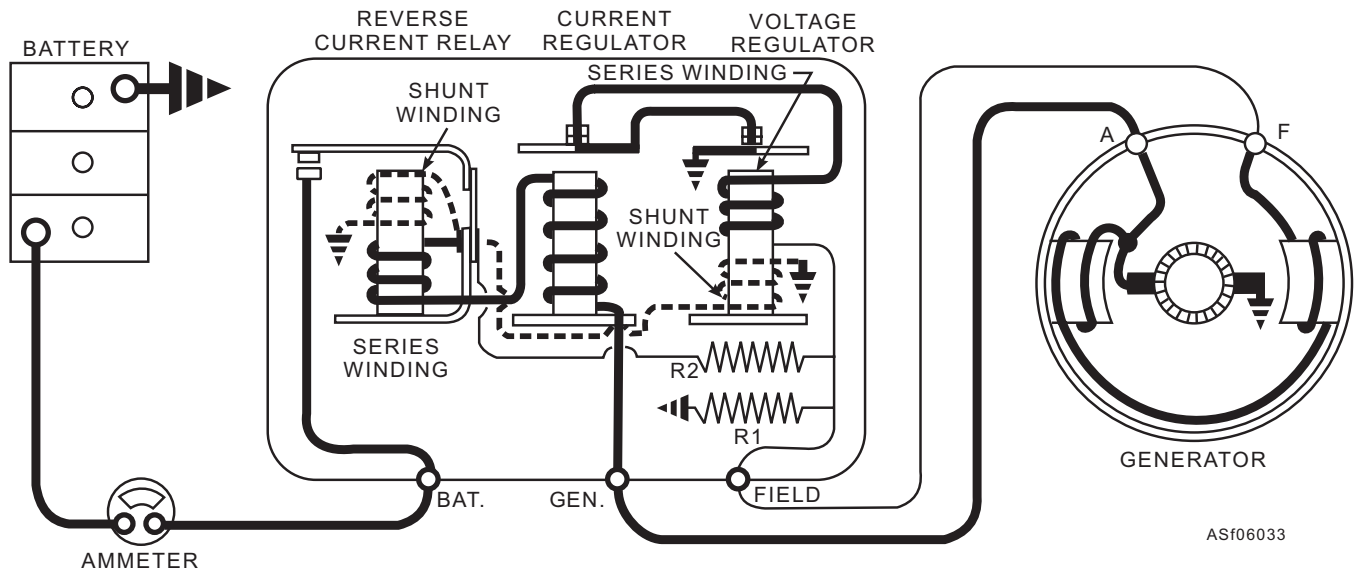

Figure 6-33.—Dc charging circuit with a vibrating-contact regulator.

Dc Reverse Current Relay

The reverse current relay prevents the battery from discharging through the generator when the engine is stopped or is running at slow speed. When the speed of the generator is increased and the output voltage of the generator becomes higher than that of the battery, the reverse current relay closes, completing the circuit from the generator to the battery. The generator powers the entire electrical system and charges the battery.

When the speed of the generator is decreased and the output voltage of the generator becomes lower than the voltage of the battery, the reverse current relay opens, which opens the circuit between the generator and the battery. At this point the generator is inoperative and the battery powers the entire electrical system.

The reverse current relay has two windings on a single core. One consists of a few turns of heavy wire in series with the charging circuit; the other consists of many turns of fine wire and is shunted across the generator.

The windings and core of the reverse current relay are assembled in a frame. A flat, steel armature with a contact point is attached to the frame by a hinge. A flat spring holds the contact points open when the battery voltage is higher than the output of the generator.

Voltage Regulator

The voltage regulator prevents circuit voltage from exceeding a preset value and maintains a constant voltage in the system. It has a series winding of many

turns of fine wire and is shunted across the generator. The shunt winding consists of a few turns of heavy wire.

The windings and core of the voltage regulator are assembled in a frame, and a flat, steel armature with a contact point is attached to the frame by a hinge. A coil spring (not shown) is attached between the armature and regulator base to hold the contact points in the closed position when the voltage regulator is not working.

Current Regulator

The current regulator protects the generator and charging circuit from overload by limiting current output to a preset value. The current regulator has a single winding of a few turns of heavy wire in series with the generator output. The entire output of the generator passes through this winding. Except for the single winding, the construction of the current regulator is the same as the voltage regulator.

Resistors

Current and voltage regulators use two common resistors mounted on the back of the regulator base; they are referred to here as R1 and R2 (fig. 6-33). R1 is connected between the regulator field terminal and ground at the regulator base. R2 is connected between the regulator field terminal and the reverse current relay frame.

R1 is connected in series with the generator field coils when either the voltage or the current regulator contacts open. R2 is connected in parallel with the

generator field coils and helps to dissipate the surge of induced voltage that occurs in the field coils when either the voltage or the current regulator operates. This induced voltage surge is due to the sudden drop of field current and the resultant decrease in strength of the magnetic field. Dissipation of this induced voltage surge reduces arcing at the voltage and current regulator contact points.

Operation

The charging system shown in figure 6-33 is in a static condition. Notice that the reverse current relay contacts are open. The current regulator and voltage regulator contacts are closed. With the contacts of the two regulators closed, the generator field circuit has minimum resistance. As the generator is driven and speed increases, the output voltage builds up because of the unrestricted increase of field voltage and current.

When the generator output voltage builds up higher than the battery voltage, the current through the shunt winding of the reverse current relay creates a magnetic field strong enough to overcome the tension of the armature spring and close the contacts. With the contacts closed, the generator is connected to the battery. The generator output flows through the battery, the series winding of the reverse current relay, and back to the generator armature, adding strength to the magnetic field created by the shunt winding.

Once the generator output voltage reaches the value for which the voltage regulator is adjusted, the magnetic field created by the winding of the voltage regulator overcomes the tension of the armature spring and pulls the armature down, opening the contacts. This inserts R1 in series with the generator field coil. The increased resistance in the field circuit lowers the field voltage and current. This results in a weaker magnetic field and a decrease in the generator output.

A surge of voltage is induced in the field winding by the collapsing magnetic field. This voltage is dissipated across R2. The reduction in generator output voltage is accompanied by a weakening of the magnetic field of the voltage regulator winding, which allows the contacts to close. When the contacts close, R1 is removed from the field circuit. Field voltage and current increase, and generator output voltage increases. This cycle may be repeated as many as 200 times per second (hence the name vibrating contact) to maintain a constant voltage in the charging system.

When electrical load requirements are high, the current regulator operates to keep the generator from

exceeding its rated maximum current output. When the generator current output reaches the value for which the current regulator is set, current flow through the series winding of the current regulator creates a magnetic field strong enough to overcome the tension of the armature spring.

When the armature is pulled down, the current regulator contacts open. This inserts R1 in series with the generator field coil circuit, thereby decreasing generator field voltage and current, and reducing the generator output current. This reduction is accompanied by a weakening of the magnetic field of the series winding of the current regulator, which allows the contact points to close. When the contact points close, R1 is removed from the field coil circuit. Field voltage and current will increase, and generator output current will increase. This cycle is repeated as many as 50 times per second to limit the generator output current to a set value.

When the generator speed decreases to a point where generator output voltage becomes less than that of the battery, current from the battery flows back to the generator, through the series winding of the reverse current relay. This opposes the magnetic field created by the shunt winding of the reverse current relay. This allows the armature to return to its original position, opening the contact points and breaking the circuit between the generator and the battery. The battery is the only source of power.

The regulator assembly provides control of the generator under all conditions. The current regulator or the voltage regulator may be operating at any one time, but in no case do they both operate at the same time.

TWO-UNIT VIBRATING-CONTACT AC REGULATOR

While the regulator for an ac generator (alternator) performs the same function as does the regulator for a dc generator, there are differences in its makeup just as there are differences between the alternator and the dc generator.

A reverse current relay is not required in an ac charging system. The one-way action of the diodes in the alternator prevents reverse current flow. The battery cannot discharge through the alternator. Also, a current regulator is not required. The design characteristics of the alternator maintain current within the limits of the alternator throughout its operating range. An alternator is sometimes referred to as a constant current machine.

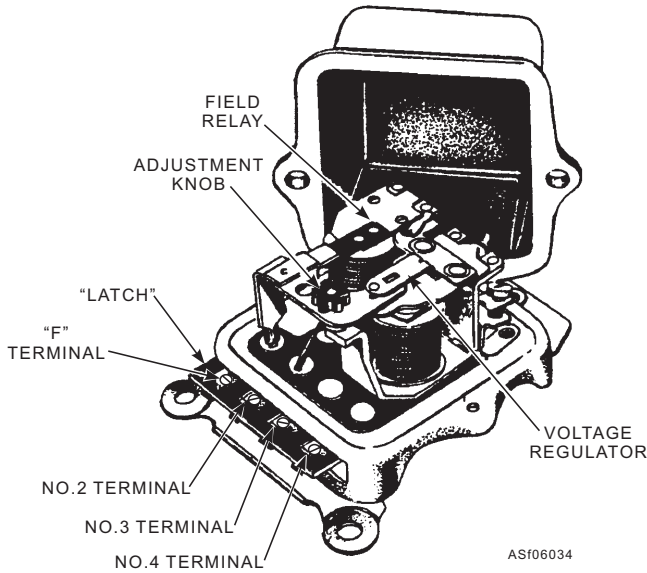

Figure 6-34.—Two-unit, vibrating-contact, ac regulator.

Although an alternator-equipped vehicle may use a number of types of regulators, the vibrating-contact regulator, shown in figure 6-34, is the one most commonly used. It consists of a field relay and a voltage regulator.

The two-unit, double-contact regulator is suitable for use in systems using either a warning light or an ammeter. The information presented here refers to a charging system that uses an ammeter.

The voltage regulator unit operates to limit alternator voltage to a preset value. The field relay unit operates to connect the rotor winding and regulator winding directly to the battery.

The operation of the double unit regulator is briefly discussed in the following paragraphs. Refer to figure 6-35 during this operational discussion.

NOTE: In some circuits, a condenser may be connected to the No. 4 terminal.

When the ignition switch is closed, the field relay winding in the regulator is connected directly to the battery. The magnetism created in the relay coil attracts the relay armature toward the core, causing the contacts to close. This connects the rotor winding directly to the battery. Current flows from the ground of the battery, through the rotor windings to the *F* terminals of the alternator and the regulator. Current continues to flow through the voltage regulator lower contacts, the field relay contacts to the regulator No. 3 terminal, and back to the battery.

When the alternator begins to operate, ac voltages are generated in the stator windings. These voltages are then changed or rectified to dc voltage, which appears at the output terminal of the alternator.

As the speed of the alternator increases, the voltage at the BAT terminal of the alternator also increases. This impresses a higher voltage through the field relay contacts and across the voltage regulator shunt

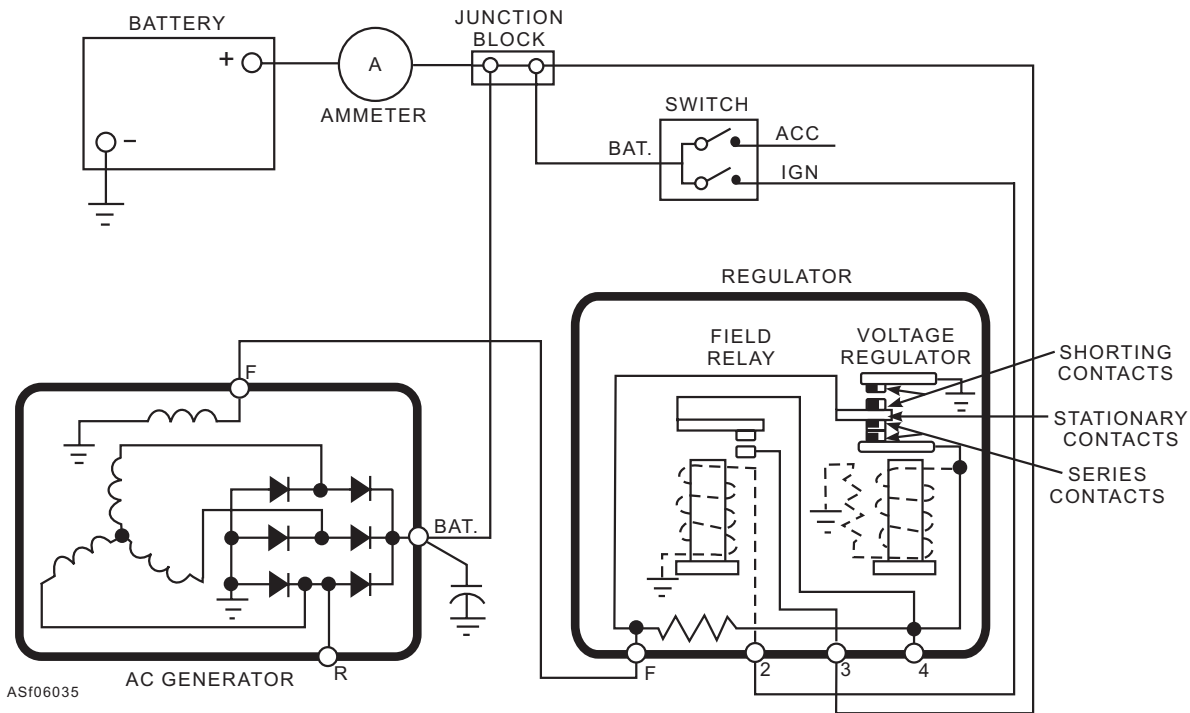

Figure 6-35.—Ac charging circuit using a vibrating-contact regulator.

winding. The increased magnetism created by the higher voltage across the winding causes the lower contacts to separate. Field current then flows through a resistor, resulting in reduced field current. This reduced field current causes the alternator voltage to decrease, which decreases the magnetic pull of the voltage regulator shunt winding. The spring causes the contacts to close, and the cycle then repeats many times per second to limit the generator voltage to a preset value.

As the alternator speed increases even further, the resistor connected across the contacts is not of sufficiently high value to maintain voltage control on the series (lower) contacts. Therefore, the voltage increases slightly, causing the upper or shorting contacts to close. When this happens, the alternator field winding is shorted and no current passes through the winding. With no current in the field winding, the alternator voltage decreases, which also decreases the magnetism in the shunt winding. The upper or shorting contacts open. With these contacts open, field current flows through the resistor and the field winding. As the voltage increases, the contacts close.

This cycle then repeats itself many times per second to limit the alternator voltage to a preset value during high speeds. The regulator controls the alternator output voltage throughout its operating speed range.

SEMITRANSISTORIZED, TWO-UNIT, VIBRATING-CONTACT REGULATOR

In the semitransistorized type of regulator, a single transistor works with a conventional voltage regulator unit that contains a vibrating-contact point to maintain the alternator voltage at a preset level. The rotor current passes through the emitter-collector of the transistor. The rotor current is turned on and off by opening and closing the emitter-base circuit through the regulator contact points. In this arrangement, current passing through the contact points is greatly reduced. The service life of this regulator is longer than that of a conventional vibrating-contact regulator.

NOTE: For a complete and detailed explanation of transistors and transistor theory, refer to NEETS, Module 7.

An example of this type of regulator is the four-terminal unit shown in figure 6-36. It consists of a field relay, a transistor, and a voltage regulator relay.

When the ignition switch is closed (fig. 6-37), the winding on the field relay is connected across the

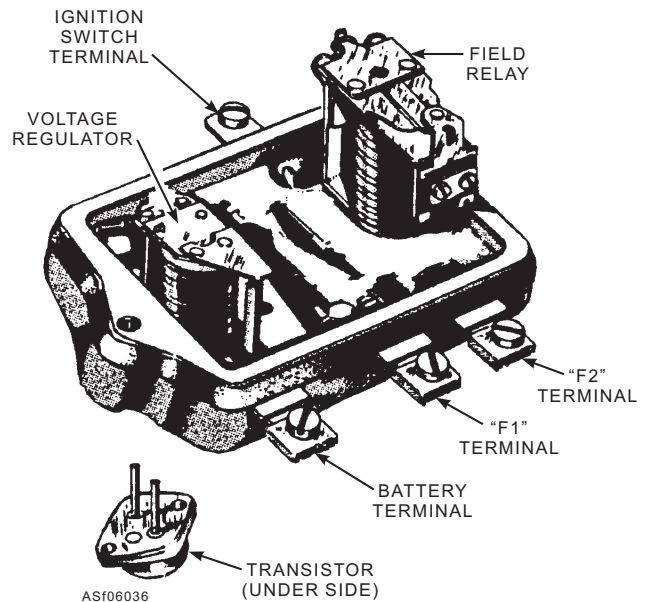

Figure 6-36.—Semitransistorized regulator.

battery. Current passing through the field relay winding creates magnetism that attracts the armature to the core, closing the field relay contacts. This connects generator field winding F2 to the battery. The field circuit is completed to ground through the emitter-collector of the transistor, the emitter-base of the transistor, and the voltage regulator contact points, which are normally held closed by the helical spring.

When the field relay contacts close, the two windings on the voltage regulator are also connected across the battery. The resulting magnetism is not strong enough, however, to overcome the adjusted tension of the helical spring, and causes the voltage regulator contacts to open. The alternator field circuit is, therefore, completed to ground as soon as the ignition switch is closed.

The alternator field windings carry full field current, producing a dc voltage at the BAT terminal on the alternator when it is in operation. When the alternator speed increases, the voltage increases. This voltage is impressed across the two windings on the voltage regulator unit. When the voltage reaches the value at which the magnetism created by both windings overcomes the spring tension, the armature is attracted toward the core and the contact points separate.

With the voltage regulator contact points open, there is no emitter-base current, and consequently no emitter-collector current. The alternator field current, therefore, is turned off when the voltage regulator contacts are open. With no field current, the generated voltage immediately decreases. This smaller voltage

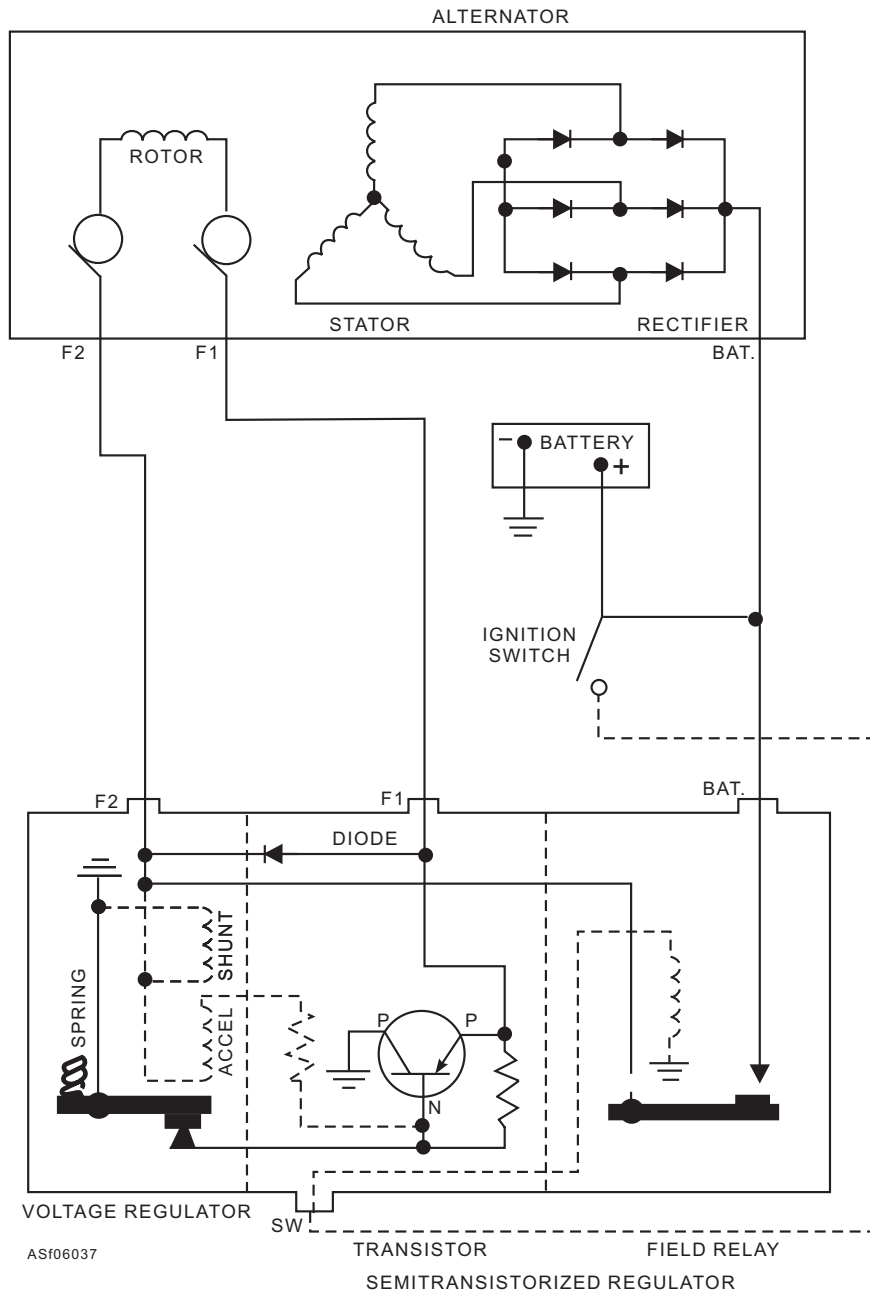
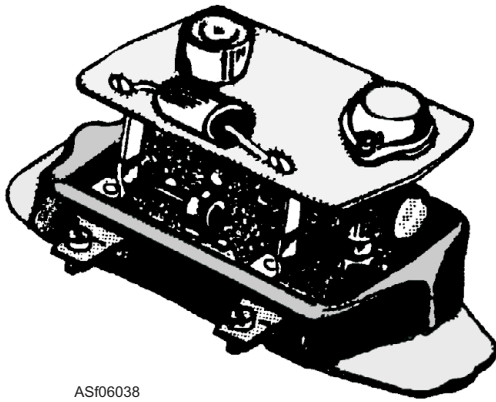

Figure 6-37.—Ac charging circuit using a semitransistorized regulator.

results in less current through the voltage regulator shunt winding, and consequently less magnetism. The weakened magnetic pull on the armature is then overcome by the spring, which pulls the armature away from the core and closes the contacts.

This cycle repeats many times per second, resulting in a constant generated voltage, which is determined by the adjusted spring tension. With higher spring tension, more magnetic pull will be required to open the contacts. Therefore, the voltage will rise to a higher value before the contacts will open, and a higher voltage setting results. Similarly, reduced spring tension gives a lower voltage setting.

Note in figure 6-37 that the voltage regulator accelerator winding (connected to the regulator F2 terminal and to ground through a resistor and the voltage regulator contacts) carries no current at all when the voltage regulator contacts are open. Thus, when the contacts open, the magnetic pull, created by the shunt winding connected directly to ground, allows the armature spring to close the contacts in a very short time interval. Once closed, the magnetic pull of the accelerator is restored and is added to the magnetic pull of the shunt winding. The contacts immediately reopen. Therefore, the accelerator winding speeds up or accelerates the frequency of vibration.



AS106038

Figure 6-38.—Fully transistorized regulator.

The resistor connected across the emitter and base of the transistor acts to prevent emitter-to-collector current leakage when the voltage regulator contacts are open during high temperatures, even though the contacts are open.

The diode (upper center) is connected directly across the rotor windings. When the voltage regulator contacts open, the sudden interruption of field current causes a voltage to be self-induced in the field coils of the rotor. The diode provides an alternate circuit in which the self-induced current can flow within the windings of the rotor. Without the diode, this voltage surge would damage the transistor.

When the ignition switch is opened, the field relay shunt winding is disconnected from the battery. A spring then pulls the armature away from the core, opening the contacts and disconnecting the rotor windings from the battery.

FULLY TRANSISTORIZED REGULATOR

The transistor regulator shown in figures 6-38 and 6-39 is a model used on some Navy equipment. It has only two terminals, contains no moving parts, and limits the alternator voltage through the combined action of the two transistors.

From the schematic diagram shown in figure 6-39, you can see that the charging circuit consists of the alternator, the regulator, the battery, the field relay, the junction block, the wiring, and either an ammeter or an indicator light.

When the ignition switch is closed, the winding in the field relay is connected to the battery. The resulting magnetism created in the core overcomes the relay spring tension and pulls the armature toward the core, closing the contacts. This completes the circuit from the battery to the POS terminal of the regulator. It also connects the winding of the indicator light relay to the battery.

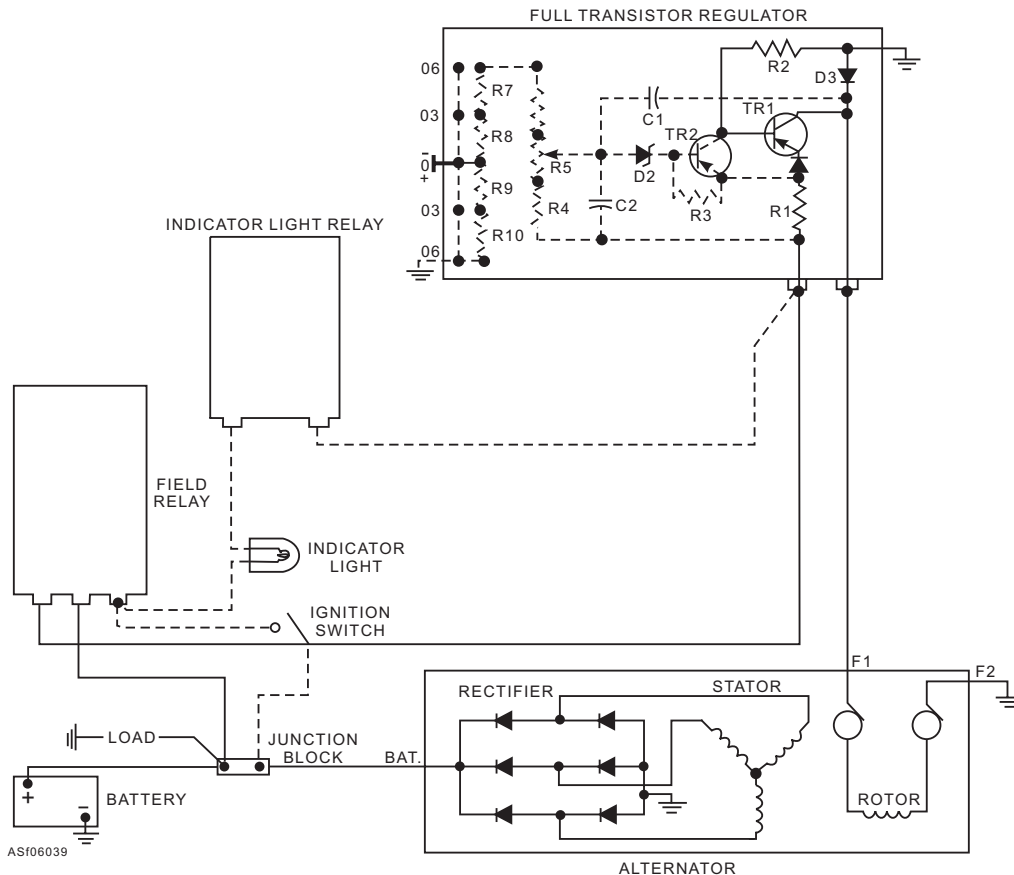

AS106039

Figure 6-39.—Ac circuit using a fully transistorized regulator.

The magnetism created in the core of the indicator light relay, because of the battery voltage, is insufficient to overcome the spring tension and open the normally closed contacts. The contacts open when the alternator voltage increases to a value greater than battery voltage. At this time the alternator is charging the battery, and the indicator light is turned off by opening the contacts.

The fully transistorized regulator performs one function only—to control the rotor current, limiting the alternator voltage to a preset value. The course voltage setting may be adjusted externally by relocating a screw in the base of the regulator. The screw contacts the series of resistors, marked R7 through R10 in figure 6-39, and makes a connection to ground at the point of contact. Internal fine voltage adjustment is accomplished by turning a slotted head screw on the potentiometer R5.

The operation of the fully transistorized regulator is similar to the semitransistorized two-unit regulator. TR1 and TR2 are PNP transistors. TR1 conducts the full battery voltage to the rotor windings to produce the rotating magnetic field. TR2 controls the operation of TR1 by sensing the output voltage of the alternator.

Internally, resistors R4 through R10 are connected in series, constituting a voltage divider circuit. R5 is a variable resistor. The voltage at the R5 tap is impressed upon the base of TR2. TR2 is operating in a forward-bias condition (turned on). The base voltage is negative in relation to the emitter voltage. While TR2 is operating in the forward-bias condition, voltage flows through the emitter-collector to provide the base voltage for TR1. With TR1 forward-biased, the battery voltage is provided to the rotor field. Diode D3 prevents the battery voltage from grounding inside the regulator.

As the alternator voltage increases, it is sensed at the voltage divider circuit. The higher potential at R5 is sensed by Zener diode D2. When the peak reverse voltage (PRV) of the Zener is exceeded, D2 conducts, placing a negative potential on the base of TR2. This will forward-bias (turn on) TR2. TR2 conducting, places the same potential on the base and emitter of TR1. This causes TR1 to stop conducting, opening the field circuit.

When the field circuit is opened, a reverse polarity voltage is induced in the rotor winding as the magnetic field collapses. This voltage is conducted to ground through D3 and back to the rotor, depleting its strength. No damage occurs to the voltage regulator circuit. With no rotor voltage, the alternator output is interrupted. The reduced voltage is sensed at Zener D2, which no

longer conducts because the voltage has now decreased below its PRV. DR2, not conducting, turns TR2 off. This allows TR1 to operate, returning current to the field circuit. The cycle repeats itself as many times as necessary to maintain the preset output.

MAINTENANCE AND REPAIR

Do not adopt a hit-or-miss approach to troubleshooting, maintenance, and repair of electrical systems. Hit-or-miss troubleshooting results in a great waste of time and may result in serious damage to one or more of the components of the electrical system. Wrong adjustments by maintenance personnel have ruined many regulators, alternators, and batteries. The technician can easily determine if a wire is “hot,” but to know the voltage and the amount of current flowing in the wire requires the use of instruments. A few quick checks with a properly connected voltmeter or ammeter will help you quickly identify and isolate electrical problems.

A good visual inspection should be made of the charging circuit before actual testing begins. Inspect the battery case for cracks and leaks. Make sure the battery posts, clamps, or cables are not broken and that the connections are not corroded or loose. Also check for insulation chaffing that could expose bare wire. The top of the battery should be clean and dry. Dirt and electrolyte on top of the battery cause excessive self-discharge. Be sure that the battery carrier is solidly mounted, in good condition, and properly secured. A loose battery carrier or battery hold-down will allow the battery to be damaged by vibration and jarring. An excessively tightened battery hold-down may buckle or crack the battery case.

Raised cell covers or a warped battery case may indicate that the battery has been overheated or overcharged. This may be important when the results of the electrical tests are analyzed. Check the level of the electrolyte in the battery. If, under normal conditions, distilled water has to be frequently added to the electrolyte, a high charging rate is indicated. These conditions require that the charging rate be checked and adjustments made if required. Likewise, if a battery has to be replaced, the charging rate should be checked to ensure the charging system is operating properly.

A variety of alternator regulators are used in automotive vehicles, and test and adjustment procedures may vary from type to type. The test procedures presented here are general in nature, and should not be substituted for the specific procedures outlined in the applicable maintenance manuals.

When the alternator charging circuit is serviced, the following precautions must be observed.

- Ensure that the polarity of the system being serviced is known so that the battery is connected properly. Reversed battery polarity will damage rectifiers and regulators.

- When using booster batteries for starting a vehicle, ensure they are connected properly to the vehicle battery. That is, connect the positive cable from the vehicle battery to the positive terminal on the booster battery, then connect the negative cable from the vehicle to the negative terminal of the booster battery. Failure to do this will result in damage to the rectifiers and regulators.

- Unless the system includes a load relay, grounding the alternator output terminal will damage the alternator and/or circuits. This is true even when the system is not in operation, because no circuit breaker is used and the battery is connected to the alternator output terminal at all times. The field or load relay acts as a circuit breaker in that it is controlled by the ignition switch.

- Ensure that you do not short the adjusting tool to the regulator base when making adjustments to the voltage regulator. To do so may result in damage to the regulator. The tool should be insulated by taping or by fitting with a plastic sleeve.

- When a vehicle battery is charged with a fast charger, ensure the vehicle battery cables are disconnected unless the fast charger is equipped with a special alternator protector, in which case the vehicle battery cables need not be disconnected. Also, the fast charger should never be used to start a vehicle, as damage to rectifiers will result.

- Ensure the alternator belt is adjusted to the proper tension.

- To prevent damage to the system, the ignition switch should be OFF and the battery ground cable disconnected before making any test connections.

- The vehicle battery must be fully charged or a fully charged battery should be installed for accurate test purposes.

- Do not attempt to polarize an alternator. Any attempt to do so will damage the alternator and the regulator.

Two-Unit Vibrating-Contact Regulator

Set up the voltampere tester (VAT) as shown in figure 6-40. With the engine off, remove the cable from the battery's positive post. Then, connect a switching device to the battery post, which will allow the circuit to be opened between the battery and the battery terminal of the alternator. Connect the positive cable of the battery (coming from the alternator) to the opposite side of the switching device. Connect the voltmeter's positive lead to the battery terminal of the alternator, and the negative lead to a good ground. Connect the negative lead of the ammeter to the battery cable on the switching device, and the positive lead of the ammeter to the battery's positive post.

Adjust engine speed to 1,500 rpm and operate for at least 15 minutes to stabilize system temperature. Cycle the system by bringing the engine back to idle, stopping, and restarting the engine. Adjust speed to 2,500 rpm and rotate the load control knob of the VAT to the VARIABLE LOAD position until the ammeter indicates about 15 amperes. The indication provided by the voltmeter is the voltage setting of the series (lower) contacts of the regulator. Make a note of the setting.

Rotate the load control knob to the 1/4-OHM POSITION and again check the voltmeter. The indication on the voltmeter is the voltage setting of the shorting (upper) contacts of the regulator. Then, refer to the manufacturer's specifications to determine if the readings are within limits. Bring the load control knob back to DIRECT and the engine back to idle.

If adjustments are necessary, they are made by changing spring tension, by adjustment screws, or by bending spring attachment bars.

Semitransistorized Regulator

The semitransistorized regulator is tested and adjusted in the same way as the vibrating contact regulator just described.

Fully Transistorized Regulator

With the VAT connected as shown in figure 6-40, adjust engine rpm to 1,500 and operate for at least 15 minutes to stabilize system temperature. Rotate the load control knob to the DIRECT position. The voltmeter will indicate the setting of the voltage regulator. Refer to the manufacturer's specifications to determine if this reading is within limits.

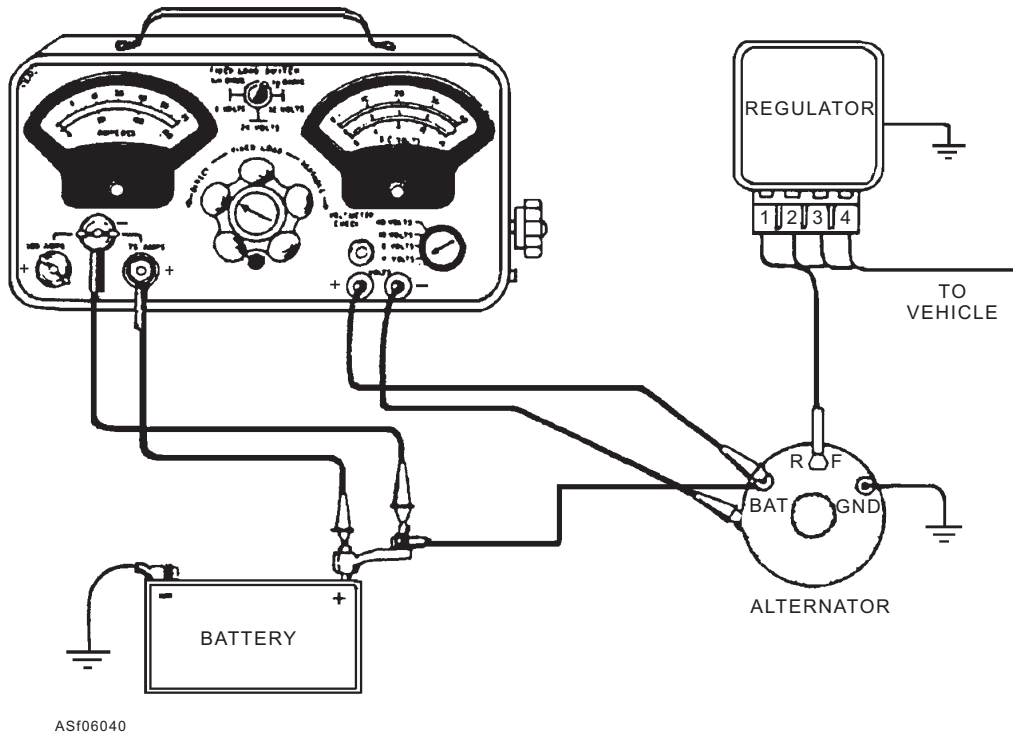

ASF06040

Figure 6-40.—Voltage regulator test.

If the regulator is adjustable, use the voltage adjustment screw to bring the regulator within the manufacturer's specifications. Regulators that are not adjustable, or regulators that cannot be adjusted within the manufacturer's specification, will need to be replaced.

Q6-15. What is the purpose of the reverse current relay in the three-unit vibrating-contact regulator?

1. To prevent the battery from discharging through the generator when the engine is not running
2. To prevent the generator from overcharging the battery through the regulator
3. To prevent the collapsed field voltage from damaging other circuit components
4. To prevent the field voltage from arcing across the contacts of the regulator

Q6-16. The voltage regulator has a series winding of many turns of fine wire and is shunted across the generator. This shunt winding consists of which of the following characteristics?

1. Many turns of fine wire
2. A few turns of fine wire
3. Many turns of heavy wire
4. A few turns of heavy wire

Q6-17. What is one purpose of the current regulator?

1. To protect the voltage regulator from an increased input voltage
2. To regulate the input voltage of the generator
3. To protect the generator and charging circuit from overload
4. To regulate the voltage regulator from decreased input voltage

Q6-18. What is one of the major differences between the voltage regulators for the alternator and the dc generator?

1. The regulator for the alternator has a greater output capability
2. The regulator for the dc generator has a greater output capability
3. The regulator for the alternator does not require a reverse current relay
4. The regulator for the dc generator does not require a reverse current relay

Q6-19. The only purpose of the fully transistorized regulator is to perform which of the following functions?

1. To control the current output of the alternator
2. To control the stator voltage
3. To control the rotor current
4. To control the armature voltage

Q6-20. *When performing maintenance on the charging system, which of the following tasks should be performed before the actual testing begins?*

1. *Perform a good visual inspection*
2. *Perform a good cleaning of the equipment*
3. *Perform a post-operational inspection*
4. *Perform a load-test on the equipment*

Q6-21. *Which of the following conditions will cause a battery excessive self-discharge?*

1. *Improperly secured battery*
2. *Dirt and electrolyte on top of the battery*
3. *Broken battery post*
4. *Warped battery case*

IGNITION SYSTEMS

LEARNING OBJECTIVES: Identify the components in an ignition system. Identify procedures for inspecting, testing, and troubleshooting ignition system components.

There are two methods used to ignite the fuel-air mixture in the cylinders of internal combustion engines. Heat of compression is one method, and it is used in diesel engines. The second method is the electric spark, and it is used in gasoline engines. This section of the chapter deals with electrical spark ignition systems. After completing this section, you should be familiar with the purpose and operation of electrical spark ignition systems.

Spark ignition may be subdivided into two classes—battery and magneto. With either, the fundamental job is to step up low voltage to a much higher value (15,000 to 20,000 volts) and to deliver the high voltage to the spark plugs at the proper time. The high voltage is capable of pushing current from one spark plug electrode to the other through the high resistance set up by the gas pressure in the combustion chamber.

BATTERY IGNITION SYSTEMS

The voltage of the vehicle battery is not high enough to force a current across the spark plug electrodes. To obtain the high voltage necessary (about 20,000 volts), a step-up pulse transformer (ignition coil) is used. The high voltage created is then delivered to the spark plug of the correct cylinder at the right time

by the distributor. The high voltage forces a current across the spark plug electrodes, creating a spark that ignites the air-fuel mixture in the cylinder.

A battery ignition system consists of two circuits—primary and secondary. The system may be conventional, contact-controlled, or transistor-controlled magnetic pulse. Some components of these circuits may differ, but in both cases the purpose is the same—to create the high voltage necessary to fire the spark plug and to deliver high voltage to the correct spark plug at the right time.

Conventional Ignition Systems

The conventional ignition system (fig. 6-41) was the only type available for many years. And, although it is gradually being replaced by the transistorized system, many are still in use.

IGNITION RESISTOR.—An ignition resistor (also known as a ballast resistor) is used in all conventional ignition systems to help control current. The ignition resistor limits current flow across the breaker points during low-speed operation, when less current is needed. This tends to prolong breaker point life.

During starting, the ignition resistor is bypassed to allow full current to the primary ignition circuit. This ensures a strong spark for starting. After the engine is started, the resistor circuit is energized.

IGNITION COIL.—The primary winding of the ignition coil consists of a few hundred turns of heavy wire wrapped around a laminated soft-iron core. When current flows in the primary circuit, a magnetic field sets up around this coil. The secondary winding consists of thousands of turns of very fine wire around the primary coil. The magnetic field from the primary coil surrounds or “links” the turns of wire on the secondary winding by induction.

If the flux linking a coil varies or changes in any way, an electromotive force is induced in the turns of the coil. This is the basic principle upon which the induction coil works. In an induction coil (such as an ignition coil), a magnetic field is set up by current from the battery flowing through the primary circuit. Unless this current flow is changing to vary the strength of the magnetic field, no voltage is induced in the secondary winding.

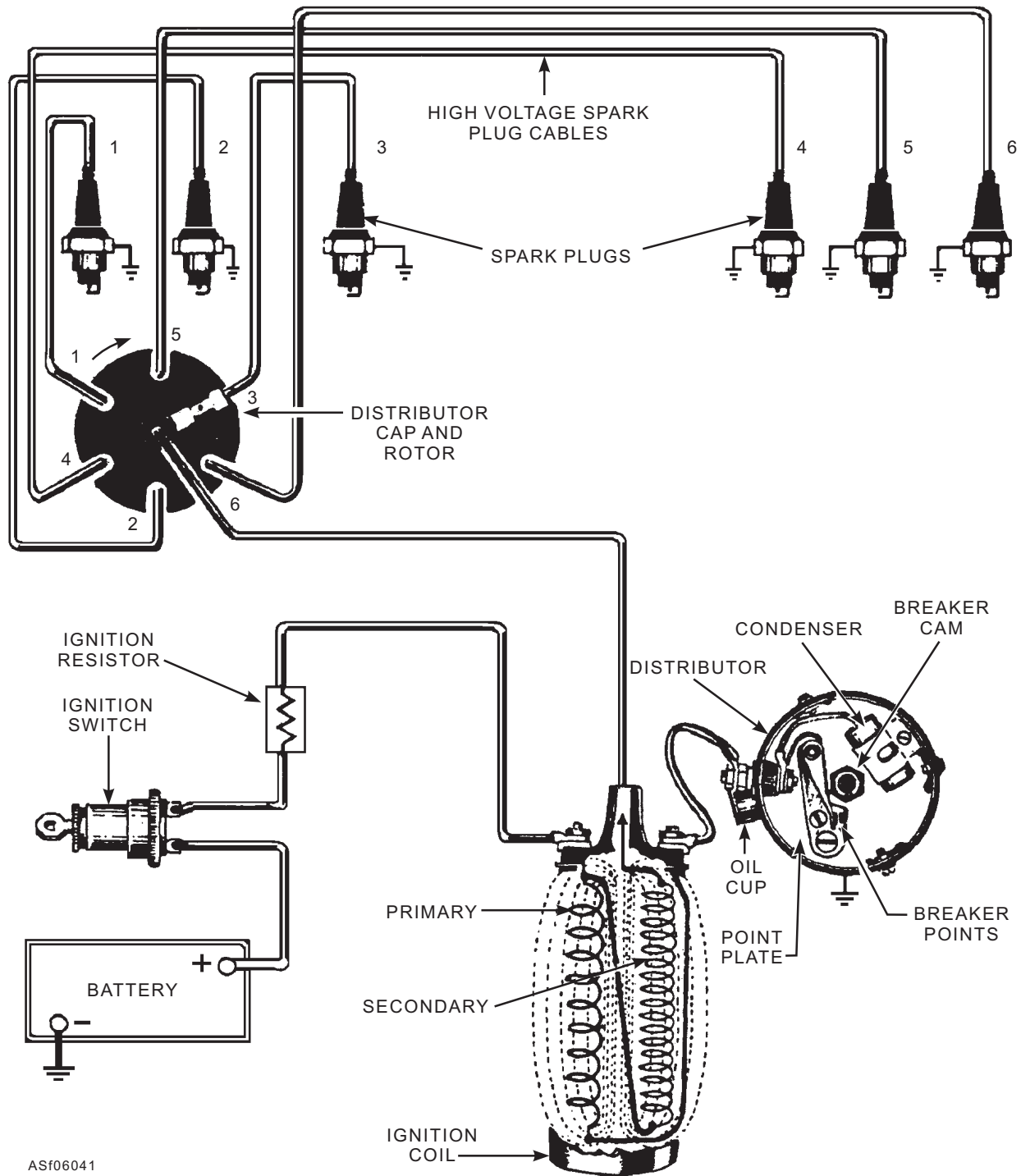

ASF06041

Figure 6-41.—Conventional battery ignition system.

Since the primary and secondary windings of an induction coil are stationary windings, some means other than movement of the windings is used to change the magnetic flux linking the coils. The effect is created by a make-and-break device (breaker points) in the primary circuit. When the breaker points are closed, current flows through the primary coil; the

magnetic field builds up around it. The magnetic lines of force link the primary and secondary windings and induce voltage in each winding. In the primary winding, the induced voltage opposes the battery voltage. For this reason, the magnetic field is not built up instantly; it requires a fraction of a second to reach full strength. This is called the saturation

time. A cutaway view of an ignition coil is shown in figure 6-42.

BREAKER POINTS.—The make-and-break device, which consists of a set of contact points and a spring, is located in the distributor. The purpose of this device is to open the primary circuit, causing the magnetic field to collapse. This collapse induces a high voltage in the secondary winding; it also causes a brief but strong flow of current in the secondary circuit. The flow of current in the secondary circuit causes a spark as it flows across the gap of the particular spark plug. This spark plug is connected into the secondary circuit by means of the distributor. The collapse of the magnetic field also induces a high voltage in the primary coil.

CAPACITOR.—If the flow of current through the primary circuit due to the collapsing field were allowed to continue, it would cause arcing across the breaker points. To reduce this arcing, a capacitor (condenser) is wired in parallel with the breaker points and grounded through the distributor housing. The capacitor takes up the current from the primary voltage. This allows the magnetic field to collapse very quickly and induces a high secondary voltage. The result is a good hot spark, which is required to ignite the fuel-air charge.

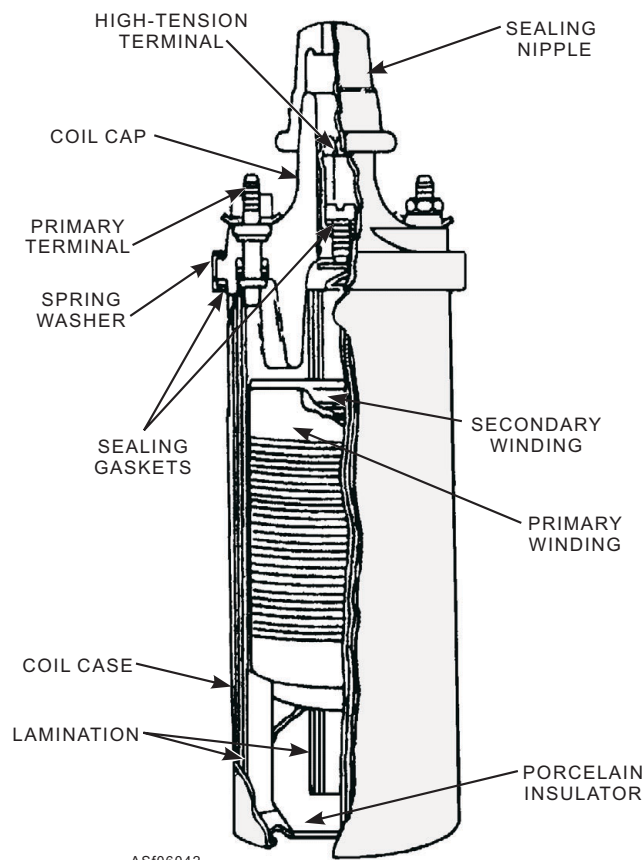

Figure 6-42.—Cutaway view of an ignition coil.

DISTRIBUTOR.—The distributor (fig. 6-43) is a mechanical device that times the ignition spark and delivers it to the right cylinder. The distributor houses the capacitor, rotor, breaker points, and breaker cam. The breaker cam and rotor turn at one-half engine speed. The distributor is driven by the camshaft. The rotor conducts the high voltage from the ignition secondary coil to the separate spark plug leads. The distributor cap is mounted on top of the distributor. It has a center terminal for the lead from the secondary coil and separate terminals for each spark plug. The breaker cam is timed so the rotor is adjacent to one of the spark plug terminals each time the primary circuit is broken (breaker points open). The leads from the distributor cap are arranged so the rotor will conduct current to the spark plugs in the firing order of the engine.

BREAKER CAM.—The breaker cam for a six-cylinder, four-stroke cycle engine is six-lobed. (An eight-cylinder cam would be eight-lobed.)

The breaker cam opens and closes the breaker points six times with each revolution of the distributor shaft. These breaker points close and open the primary circuit six times in each two revolutions of the engine crankshaft. This collapses the magnetic field and produces a high voltage in the secondary circuit. The breaker cam and rotor turn together. The rotor is aligned with the proper spark plug contact each time a cam lobe opens the primary circuit.

TIMING ADVANCE UNIT.—Timing advance is accomplished in the distributor. A short time is required to ignite and burn the fuel-air mixture and develop power. This time is practically the same at all engine speeds. At high speeds, the timing must advance so that the spark can occur earlier than at low engine speeds if combustion is to be completed at the most effective time in the operating cycle.

There are two types of automatic timing advance mechanisms. They are the centrifugal advance mechanism and the vacuum-advance mechanism. They may be used separately or together. The centrifugal advance mechanism operates by a pair of weights that are thrown out against spring tension by centrifugal force as the engine speed increases. Movement of the weights advances through a linkage to the breaker cam. This mechanism, usually found in the lower part of the distributor housing, provides a smooth advance and retard of the timing with changes in engine speed.

The vacuum-advance mechanism also advances and retards the timing according to engine load. It uses

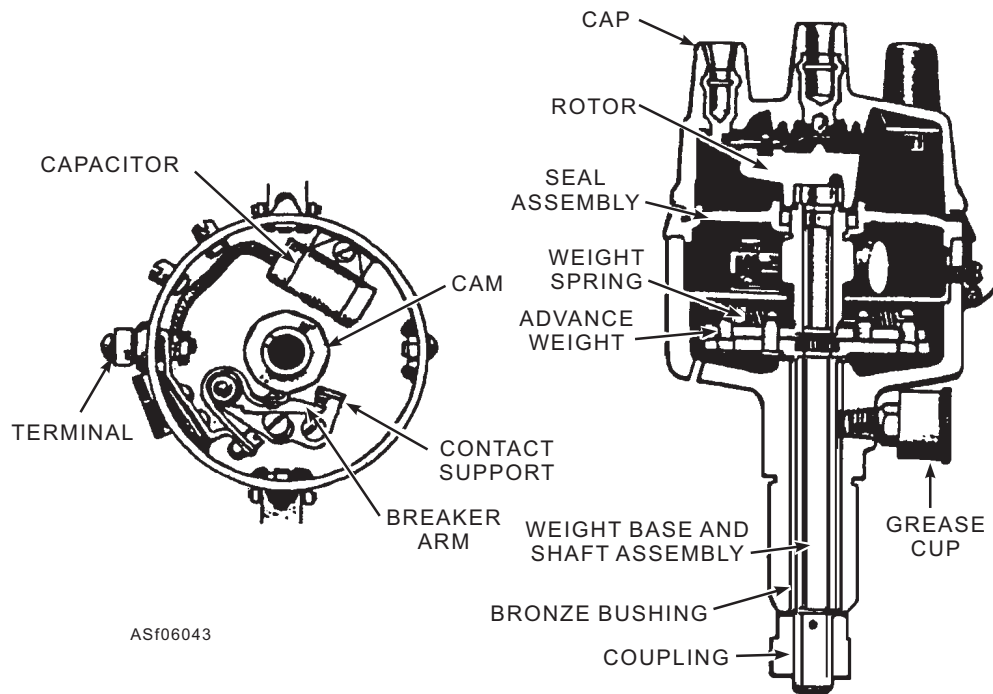

Figure 6-43.—Side and top view of a distributor.

a spring-loaded diaphragm connected by a linkage to the distributor and by a vacuum passage to the carburetor. The opening to the carburetor is on the atmospheric side of the throttle when the throttle is in the idling position. There is no advance in this position because the opening is under atmospheric pressure. As the throttle opens, it swings past the opening of the vacuum passage, exposing the advance mechanism diaphragm to intake manifold vacuum. The diaphragm operates the advance-mechanism linkage. It rotates the breaker plate and breaker points in the direction of distributor rotation. This causes the breaker points to open earlier, which advances the time that the spark occurs in the cylinder.

Transistor Ignition Systems

The transistor ignition system is designed to overcome some of the drawbacks of the conventional ignition system. The output of the conventional ignition system is limited to the amount of current in the primary circuit. Approximately 5 amperes of current can be carried in the primary circuit to maintain a reasonable breaker point life. Any increase in current shortens the breaker point life.

The transistor can switch large amounts of current through the action of a very small control current. The switching action involves no moving parts and is instantaneous when the circuit is designed properly. In

a contact-controlled system, conventional breaker points turn the transistor emitter-base circuit ON and OFF at the proper time in relation to the engine timing. Because of the low voltage controlled by the breaker points (one-half to three-fourths of an ampere), their life is greatly increased over that of the conventional ignition system.

There are several advantages offered by the transistorized ignition system. These are extended breaker point life, extended periods between engine tuneups, extended spark plug life, and higher available voltage at the spark plugs.

There are two basic types of transistorized ignition systems. They are the contact-controlled systems and the transistor-controlled magnetic pulse system. The basic difference between the two is the manner in which the emitter-base circuit within the transistor is controlled. This control can be exercised by either mechanical or electronic means.

NOTE: Transistors are discussed in NEETS, Module 7. You should review this module for a better understanding of transistors.

CONTACT-CONTROLLED SYSTEM.—In the conventional battery system, when the ignition switch is closed, current flows through the ignition coil primary winding and the breaker points. The breaker points carry the full primary current. Since the amount

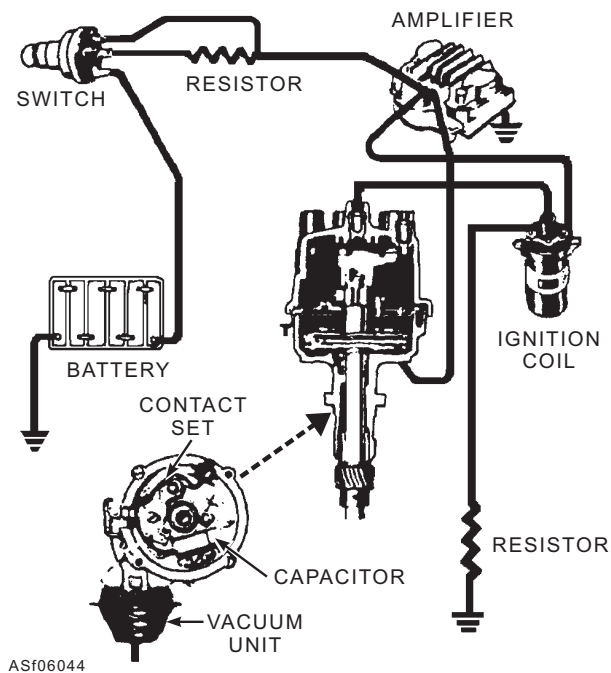

Figure 6-44.—Contact controlled transistor battery ignition system.

of current the breaker points can carry is limited, the output that can be obtained from the coil is also limited.

In the contact-controlled system (fig. 6-44), the breaker points carry only a very small emitter-base current of the transistor. The larger current of the coil primary is carried through the emitter-collector of the transistor. When the breaker points open, the

emitter-base current stops. With no emitter-base current, the emitter-collector current stops. The emitter-collector is the primary circuit. The resistor connected to the primary circuit establishes the proper amount of primary current. The use of a capacitor in the distributor is optional.

The contact-controlled system in figure 6-44 shows the ignition switch resistor bypass, which functions during cranking. On other systems, the resistor bypass may be connected to a terminal on the starter solenoid or a separate relay.

TRANSISTOR-CONTROLLED MAGNETIC PULSE SYSTEM.—A simplified wiring schematic for a transistor-controlled magnetic pulse ignition system is shown in figure 6-45. Many of the components in this system are essentially the same as those used in the conventional and contact-controlled systems. Note that in this type of ignition system, no contact points are used. The ignition coil is similar in appearance to the conventional ignition coil, but is quite different electrically. The ignition coil for the transistor-controlled magnetic pulse ignition system has a different number of wire turns in its primary and secondary windings. The two coils are not interchangeable.

The magnetic pulse distributor is similar in external appearance to the conventional distributor, and some internal features are the same. The centrifugal advance and vacuum advance mechanisms are the same in both units. However, the breaker cam, contact points, and

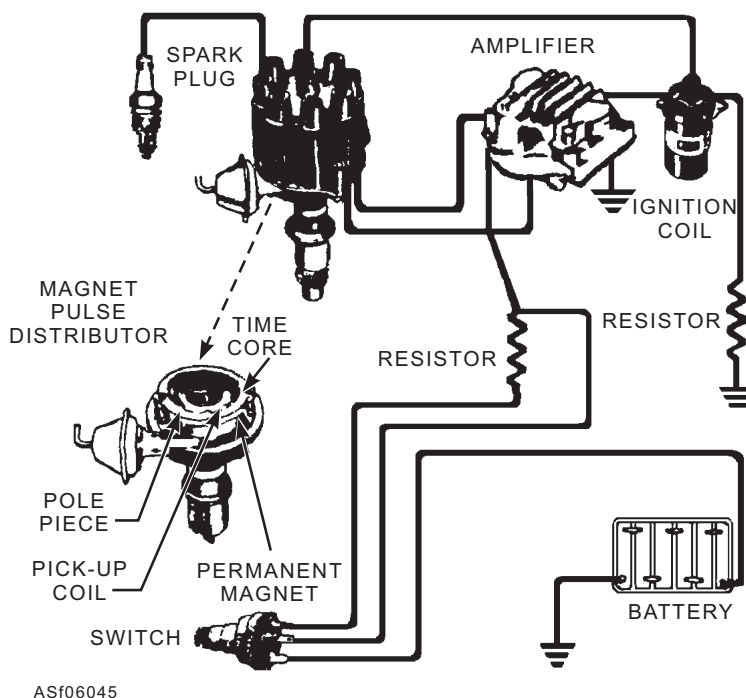

Figure 6-45.—Transistor controlled magnetic pulse battery ignition system.

condenser used in the conventional distributor are not used in the magnetic pulse distributor. The magnetic pulse distributor uses a permanent magnet, a timer core, and a pickup coil. These units produce an alternating voltage when the distributor is in operation. This voltage is transferred to the electrical control section of the ignition pulse amplifier.

The ignition pulse amplifier functions as a set of contact points to interrupt the current in the primary circuit. The voltage developed by the distributor is increased by the pulse amplifier and applied to the base of a transistor located in the control section. The control transistor acts as a switch and is controlled by the voltage supplied to its base circuit. Other electrical control devices for the transistor are also located in the control unit.

For ease of understanding, only the system's basic operation will be discussed. Assuming that the ignition switch is in the run position, current flows through the emitter-collector of the transistor and the primary winding of the ignition coil. Current flow in the primary winding builds a magnetic field in the primary and secondary windings, just as it does in the conventional system.

When the magnetic pulse distributor generates a voltage in its winding, the voltage is carries to the

electrical control portion of the ignition pulse amplifier. This voltage is amplified and used to increase the voltage on the base of the transistor to a value higher than that on the emitter. The current flow through the ignition coil primary windings stops.

With no current flow in the primary ignition winding, the magnetic field within the coil collapses about the windings. The higher voltage induced in the secondary winding is then impressed upon the secondary circuit to fire the spark plug. When the voltage reaches a sufficient value to jump the gap between the electrodes at the plug, a spark is created that ignites the fuel-air mixture in the cylinder of the engine.

The transistor acts as the trigger to interrupt the primary circuit to allow secondary voltage to be produced. Since the transistor is capable of carrying more current than the contact points, more secondary output voltage is available at all engine speeds.

The three basic ignition systems are compared in figure 6-46.

TROUBLESHOOTING IGNITION SYSTEMS

Before you make any test, conduct a thorough visual inspection of the ignition system. Check the

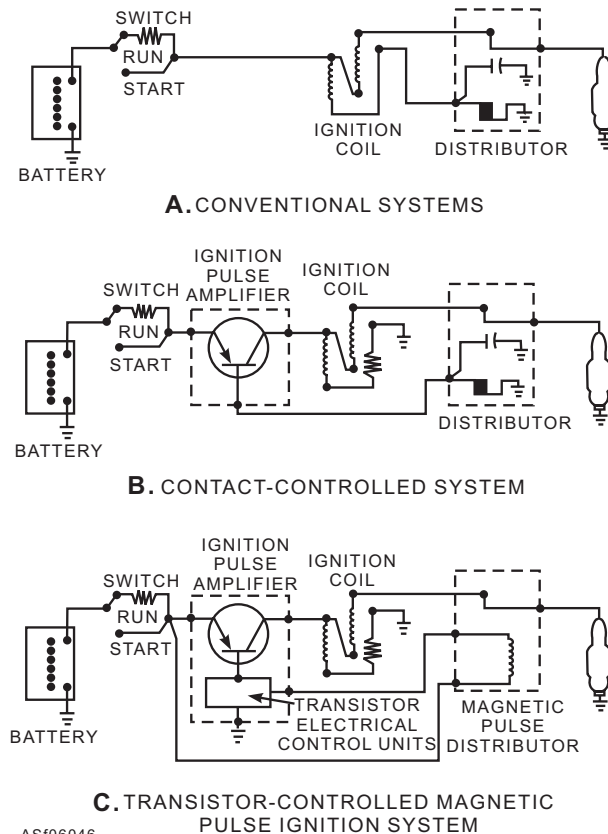

ASf06046

Figure 6-46.—Comparison of the three basic ignition systems.

battery's terminal posts and cables. Connections must be clean, tight, and free of corrosion. Check for obvious damage in the primary wiring, such as broken or loose wires, or frayed insulation. All connections must be clean and tight.

Pull the ignition coil's high voltage lead out of the coil tower. Check the tower for signs of corrosion or burning. If it is corroded, clean it with a round brush or sandpaper wound around a pencil. Examine the tower carefully for any sign of flashover (high-voltage current leaving the intended path and jumping down, or around, directly to ground). Flashover can be caused by moisture or dirt on the coil extender, a corroded tower interior, or by failing to have the high voltage lead pushed fully into the tower. If flashover has cracked the tower or left a burned path (carbon track), replace the coil. Check for correct coil polarity. The coil must be connected into the primary circuit so that the positive and negative markings of the coil correspond to the battery connections. In a negative grounded system, the negative terminal of the coil must be connected to the distributor where it is grounded through the breaker points. By connecting the coil in this manner, the center electrode of the spark plug assumes a negative polarity.

It takes less voltage to cause electrons to move from a hot to a cold surface. Since the center electrode of the plug is always hotter than the side (ground) electrode, current flow must be from the hot center electrode to the cooler side electrode. By giving the center electrode a negative polarity, current flows in this manner.

If the coil is connected so that polarity is reversed (spark plug center electrode positive), up to 40 percent more voltage is required to fire the plugs (fig. 6-47). This condition could result in hard starting, missing, and eventual coil failure.

System Tests

There is a quick test you can use to try to localize problems with the ignition system. First, remove the secondary coil lead from the distributor cap. Hold it approximately 3/16-inch from ground while you crank the engine and observe the spark. A bright blue spark indicates proper operation of the primary circuit and the secondary winding of the ignition coil. That means that troubleshooting can be limited to the distributor cap, rotor, spark plug leads, and spark plugs. A yellow spark, on the other hand, would indicate that the malfunction is in the primary circuit or the secondary winding of the ignition coil.

PRIMARY CIRCUIT TESTS.—Three basic voltmeter tests can be made to isolate high resistance areas or components in the primary circuit. They are shown in views A, B, and C of figure 6-48.

NOTE: The voltage readings and test connections used here are for a 12-volt, negative ground system. Always use the test specifications given by the manufacturer for any specific system.

Battery-to-Coil Test.—Connect the voltmeter as shown in figure 6-48, view A. Connect a jumper wire

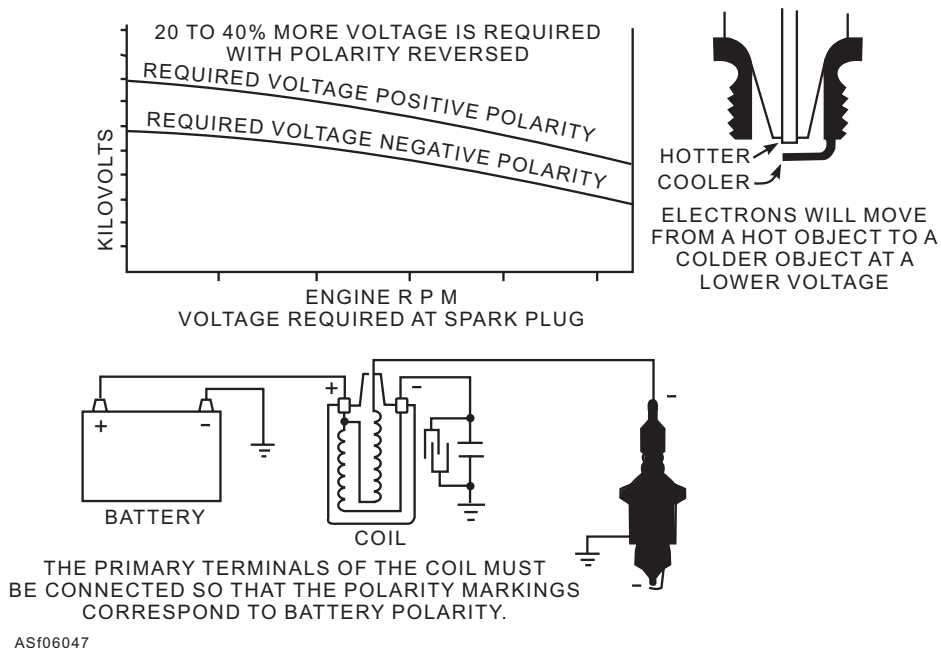

Figure 6-47.—Correct coil polarity and current flow for a negative grounded system.

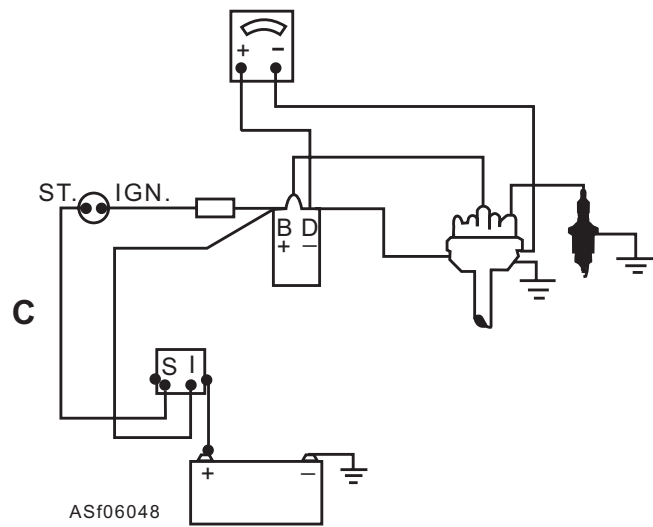
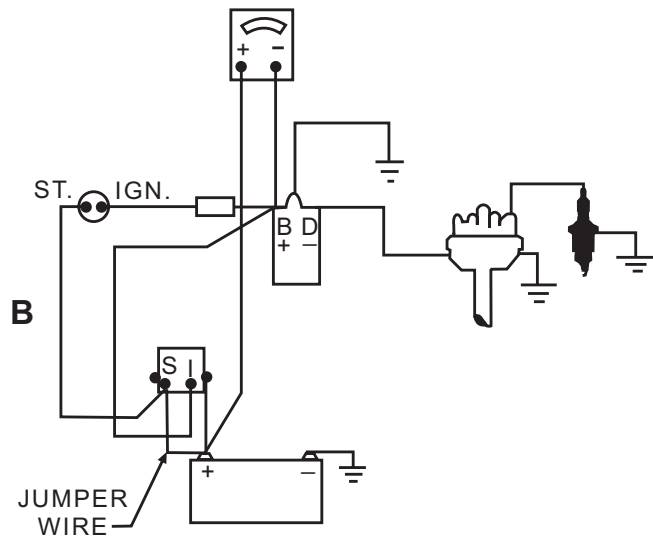
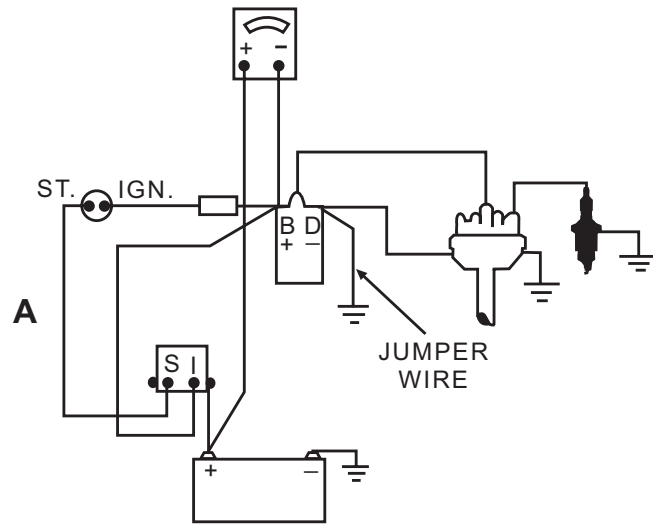

Figure 6-48.—Voltmeter connections for resistance tests of the primary circuit.

from the distributor connection of the coil to ground. With the ignition switch on and the points closed, voltage drop should not exceed 6.9 volts. If the drop exceeds 6.9 volts, a high resistance exists in the resistor, ignition switch, or the wiring between the battery and the coil. A drop of less than 4.5 volts indicates a shorted resistor.

Starting Ignition Circuit Test.—Connect the voltmeter as shown in figure 6-48, view B. Remove the secondary coil wire from the distributor cap and ground the wire. With the ignition switch off, crank the engine by placing a jumper wire from the battery positive post to the *S* terminal of the starter solenoid or relay. The voltage drop should not exceed 0.1 volt. If the drop exceeds 0.1 volt, a high resistance exists in the starter solenoid, relay contacts, or in the wiring between the starter solenoid or relay and the coil.

Coil-to-Ground Test.—Connect the voltmeter as shown in figure 6-48, view C. With the ignition switch on and the points closed, the voltage drop should not exceed 0.1 volt. If the drop exceeds 0.1 volt, a high resistance exists either in the coil-to-distributor wire, the engine-to-frame ground strap, the distributor-to-engine mounting, or in the breaker points. When you isolate the malfunction to one area, continue testing that area.

If you have not located the malfunction after you make these tests, remove the coil, resistor, and condenser and test them separately.

SECONDARY CIRCUIT TESTS.—If preliminary testing indicates that the malfunction is in the secondary circuit, the defect can be located by making the following tests.

Test 1.—Use a megger and follow the instructions provided with it. Test the distributor cam, rotor, and spark plug leads for insulation breakdown, cracks, or opens.

Test 2.—Remove and thoroughly examine the spark plugs. A plug that exhibits any of the conditions shown in figure 6-49 (except F, G, and H) may be reconditioned and reused. A plug exhibiting any of the conditions in F, G, or H must be replaced. The cause for the damage must also be corrected.

Repair and Adjustment

The repairs and adjustments required on a battery ignition system are comparatively simple to perform. To achieve good equipment performance and economic

operation, you must exercise care and follow correct procedures.

DISTRIBUTOR.—You can replace breaker points with the distributor installed. However, it is usually better to remove the distributor from the engine. This gives you easier access to the breaker points. It also enables you to inspect and repair other components in the distributor.

With the distributor cap removed, scribe a line across the junction of the distributor housing and the engine block. Scribe another line on the distributor housing in line with the center of the rotor contact strip. These lines mark the relative positions of the parts, which will facilitate reassembly.

Disconnect the primary lead and the vacuum advance vacuum line. Remove the distributor from the engine. Clamp the distributor in a soft-jawed vise. Take care not to damage the drive gear or housing.

Before you attempt to remove the breaker points (with the distributor on or off the engine), stuff small rags in any hole or opening in the breaker plate through which small screws or nuts may fall. Note the location and position of the primary lead-in and condenser wires before disconnecting them.

Remove the used points. Thoroughly clean the mounting area and the breaker cam, and install the replacement points.

The condenser is generally replaced at the same time the points are replaced. However, if the condenser is to be reused, it should be tested for capacity, resistance, and leakage. If a new condenser is used, it should also be tested. Compare the results to the manufacturer's specifications for the equipment at hand.

With the points and the condenser installed, rotate the breaker cam until the points close. Check the alignment of the contacts. If both contacts are flat, the entire surface should contact at the same time. If both contacts are convex or if one is flat and the other convex, contact should be in the center. If alignment is incorrect, bend the stationary contact bracket to provide correct alignment.

NOTE: Never attempt to align the points by bending the movable arm.

The point gap is the amount of opening between the contacts when the points are fully opened by the breaker cam. This is a critical area and must be closely set. If the gap is too small, the points arc and burn; if the

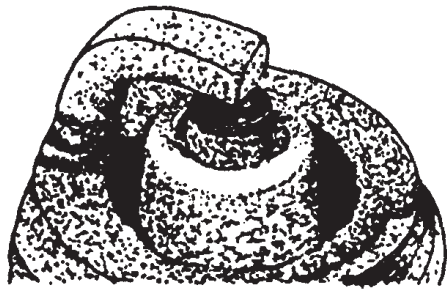

A. NORMAL

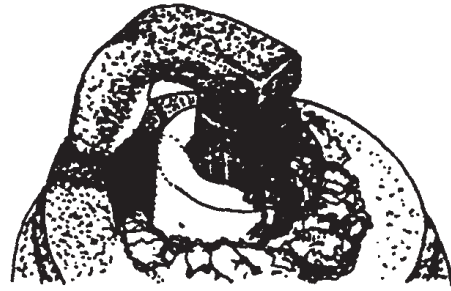

B. CORE BRIDGING



C. COLD FUELING (FUEL)

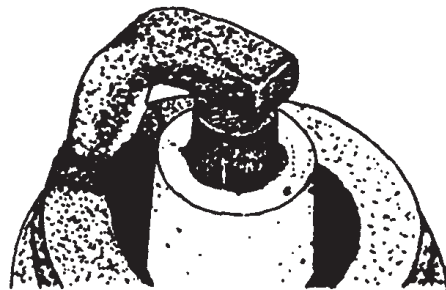

D. OVERHEATING



E. WET FOULING (OIL)



F. SUSTAINED PREIGNITION

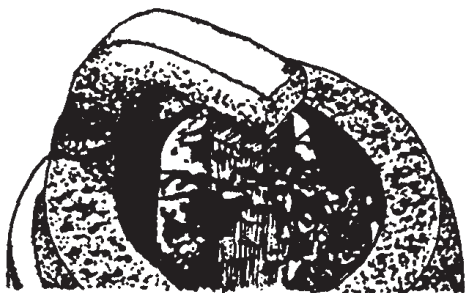

G. CHIPPED INSULATOR

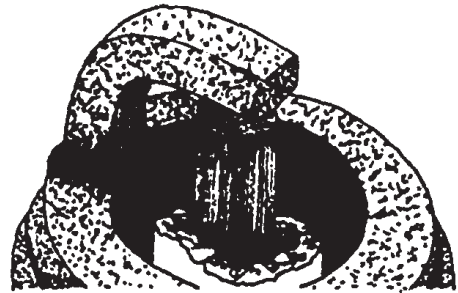

H. MECHANICAL DAMAGE

ASf06049

Figure 6-49.—Examples of spark plug appearances.

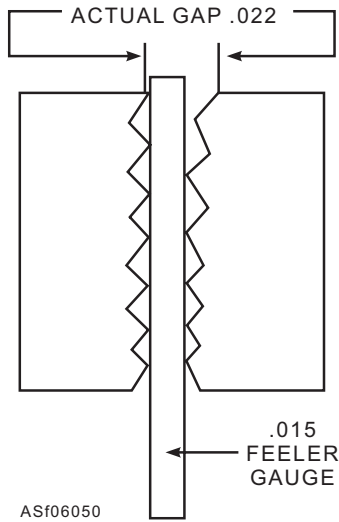

Figure 6-50.—False setting given by feeler gauge for used points.

gap is excessive, saturation time for the coil is reduced and high-speed missing occurs.

The gap for new points may be set initially with a feeler gauge. This is done by turning the breaker cam until the point rubbing block is on the highest point of the cam lobe, and then moving the stationary point plate until a feeler gauge of the correct thickness is a snug fit between the contacts. Refer to the manufacturer's specifications for the correct gap.

As shown in figure 6-50, however, used points cannot be gapped accurately with a feeler gauge. The gauge measures between the high spots while the actual point opening is much greater. Note that a .015 feeler gauge is a snug fit, but the actual gap is .022. The best method of obtaining the necessary accuracy for setting used points is the use of a dwell meter.

Dwell (often called cam-angle) refers to the distance in degrees of breaker cam rotation that the breaker cam revolves from the time the points close until they are opened again (fig. 6-51). The dwell for any given set of breaker points is controlled by the point gap, so the two must be considered together.

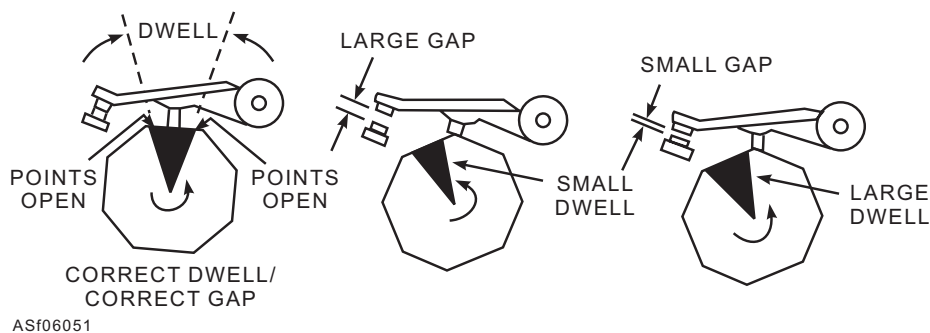

Figure 6-51.—Relationship of dwell and point gap.

If the point gap decreases, dwell increases; if point gap increases, dwell decreases. Point gap and dwell are inversely proportional.

Once the point gap has been set, the breaker arm spring tension should be checked. Use an accurate ounce scale. If the pressure is excessive, rapid wearing of the rubbing block can cause the point gap to narrow, retarding the engine timing and increasing the dwell. Too low a pressure can cause the points to bounce, creating a high-speed miss.

With the rubbing block positioned on the low point between cam lobes, hook the scale at the contact point edge. Pull at right angles to the moveable arm, and check the pressure just as the points separate. Compare to the manufacturer's specifications. If the pressure is incorrect, refer to the applicable maintenance manual for adjustment procedures. Ensure that all wires are correctly connected and clear of all moving parts. Remove rags that were used to plug openings.

Apply a thin coat of high-temperature grease to the breaker cam. Do not use engine oil or low-temperature grease as it will be thrown off and onto the points. On distributors equipped with a felt wick oiler under a lift-off rotor, moisten with engine oil (3 to 5 drops). Lubricate the point pivot pin and bushing, the centrifugal advance mechanism, and the breaker plate bearing surfaces very lightly with engine oil. If an outside oiler is provided, apply 5 to 7 drops of engine oil.

CAUTION

Lubricate distributor parts sparingly. Lubricant on the points may cause rapid burning.

If you have a distributor test machine, use it to check the distributor for dwell, vacuum and centrifugal advance, point bounce, bent shaft, worn bushings, worn breaker cam, etc.

If the distributor was marked before removal, as suggested, and the engine has not been cranked since the distributor was removed, installation is simple. Align the rotor with the scribe mark on the distributor housing, align the scribe marks on the housing and engine block, and insert the distributor. As the distributor drive gear meshes with the camshaft gear, the rotor turns a small amount. Pull the distributor up far enough to disengage the gear, and turn the rotor back far enough to compensate for the turning and push down again. When the housing is flush against the block, the scribe lines will be aligned. Install the hold-down bolt, clamp it, and lock the distributor in place.

If the distributor does not bottom, do not attempt to force it down. The distributor shaft is not aligned with the oil pump shaft slot or tang. Hold firm pressure on the distributor housing and crank the engine. When the shafts line up, the distributor drops into place.

If the engine was cranked while the distributor was out, remove the No. 1 spark plug, and crank the engine until compression can be felt. Continue to turn the engine until the timing marks are lined up with the stationary pointer. (The timing marks are located on the crankshaft vibration dampener or flywheel.) The engine is now ready to fire the No. 1 cylinder.

Align the housing-to-block scribe marks and turn the rotor to align with the No. 1 spark plug tower on the distributor cap. Note that the points are just starting to open. Insert the distributor. Allow for this rotor movement as the gears mesh. When the installation is correct, the distributor is fully bottomed, the points are just opening, and the rotor points to the No. 1 spark plug tower on the distributor cap. This initial timing setting will suffice for starting the engine.

NOTE: Refer to the manufacturer's manual for specific instructions on setting the timing.

To time the engine to manufacturer's specifications, clean all the grease and dirt from the timing mark and reference pointer. Draw a chalk line over the timing mark to make it more visible. Connect the timing light to the high-tension lead of the No. 1 spark plug and the power leads to the power supply. Connect a tachometer to the primary circuit of the distributor. Warm the engine to normal operating temperature and adjust the idle speed. Aim the timing light flashes at the timing mark and reference pointer. If the timing mark and pointer do not line up, loosen the distributor and turn it in its mounting until the timing mark does align with the pointer. Secure the distributor.

Also check to see if the automatic advance mechanism is working. This is done by keeping the timing light aimed at the timing mark and gradually increasing the engine speed. If the advance mechanism is working, the timing mark should gradually move away from the pointer. If the timing mark fails to move as you increase the engine speed or if it hesitates and then suddenly jumps, the advance mechanism is not functioning properly and must be repaired.

A quick simple check for correct coil polarity can be made by using an ordinary wooden pencil to prevent the possibility of electrical shock. Remove any one of the spark plug wires. Place the lead of the pencil between the spark plug wire and the plug. Start the engine and observe the spark (fig. 6-52). If it flares or has a yellow tinge on the wire side, polarity is reversed. If it flares or has a yellow tinge on the plug side, polarity is correct. Most ignition coil terminals are properly identified with a + or - marking.

Because changing the gap changes the timing, point gap, or dwell, must be set before you attempt to time the engine. If used points are to be reused, or the gap setting is to be checked with the distributor installed, connect a dwell meter (following instrument manufacturer's instructions). With the engine idling, check the dwell. Compare the dwell reading with the manufacturer's specifications. If the dwell reading is incorrect, adjust the point gap.

Remove the secondary coil lead from the distributor cap and ground it. Remove the distributor cap and rotor. With the dwell meter connected as before, crank the engine and adjust the points as necessary (while cranking) to obtain the correct dwell. Replace the rotor and distributor cap and reconnect the coil secondary lead. Start the engine and check the

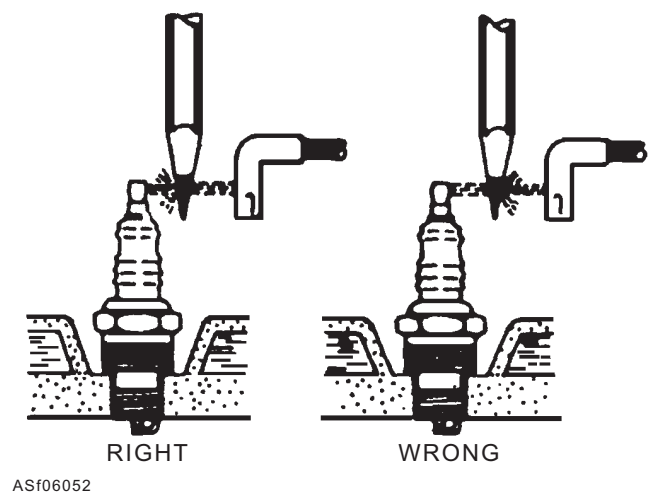

AS106052

Figure 6-52.—One method of checking coil polarity.

dwel. It should not have changed more than 3 degrees. If you note a greater change, the distributor has worn bearings or a worn cam and should be removed for repair.

SPARK PLUGS.—When plugs receive periodic cleaning and gapping, they will function better and last longer. Spark plug wires should be carefully removed by grasping them close to their terminals for the pull. Do not jerk them from the spark plug terminal. Loosen each plug one or two turns, and then use low-pressure compressed air to blow out any dirt around the spark plug hole. This prevents foreign matter from entering the cylinder.

WARNING

Always wear safety goggles when working with compressed air.

Remove the plugs and ensure that the gaskets (where used) are also removed. As you remove the plugs, keep them in order so that any peculiar condition of any plug can be related to a specific cylinder.

The plugs shown earlier in figure 6-49 illustrate some of the plug conditions that may be encountered. The cause for each is discussed below.

View (A) shows a plug from a mechanically sound engine, running at the correct temperature. Some deposits, light tan or gray in color, are present, but there is no evidence of burning. Some gap growth has occurred, but not in excessive amounts.

View (B) shows a plug from an engine having excessive combustion chamber deposits. This is most prevalent in engines operated at slow speeds and in start-stop driving.

View (C) shows a plug from a cold running engine. The deposits are unburned fuel.

View (D) shows a plug from an engine that was running too hot due to over-advanced timing or to cooling system blockage.

View (E) shows a plug from an engine using excessive amounts of oil. The plug is drowned in oil that was bypassed through the rings or valve guides.

View (F) shows a plug from an engine with severe preignition. Preignition can be caused by an overheated plug, a piece of glowing carbon, a hot valve edge, etc. The damage shown is a result of temperatures in the combustion chamber in excess of 2,700°F.

View (G) shows a plug from an engine that ran normally. The damage to the plug was caused by the mechanic attempting to bend the center electrode.

View (H) shows a plug from an engine that had a foreign object in the combustion chamber.

The plugs shown in views (F), (G), and (H) cannot be reused, but the others can be reconditioned.

Before you attempt to clean a plug, remove oily deposits with an approved solvent. This is to prevent the cleaning material from soaking and packing into the area around the center electrode insulator.

A machine of the type shown in figure 6-53 is used to clean (sand blast) and test spark plugs.

Following the manufacturer's operating instructions, clean the plugs, blasting only long enough to remove the deposits. Prolonged blasting damages the center electrode insulator.

Once cleaning is completed, the electrodes must be filed clean and square. The machine blast does not clean this area. If the electrodes are not filed clean, the required voltage remains high and the plug may misfire.

Use a fine cut point file to file the end of the center electrode flat. This produces clean, sharp edges that improve plug performance. Remove only enough metal to clean and square the electrodes.

Use a round wire gauge (not a feeler gauge). Set the gap to the manufacturer's specifications by bending the side electrode.

Testing spark plugs outside the engine can be very misleading. There is no true relationship between firing

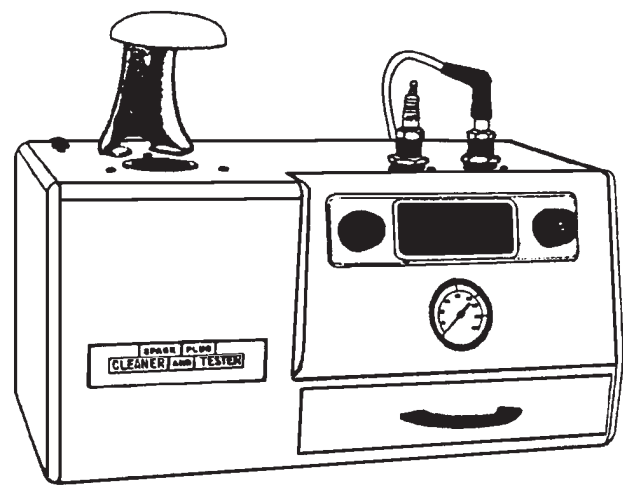

Figure 6-53.—Spark plug cleaning and testing machine.

a plug in compressed air at room temperature (which is the condition in the testing unit) and firing a plug in an operating engine. In the operating engine, voltages are higher, air-fuel mixtures are present, and the high temperatures in the cylinders aid ignition. If these factors are kept in mind, spark plugs can be successfully tested.

Do not discard plugs that show a bluish light just above the shell while they are being tested. This is a corona discharge caused by the presence of a high-tension field. It does not affect plug performance. Make sure the insulator is clean and dry before testing. If a spark comes through the insulator to the plug shell, it is an indication that the insulator is cracked. Sometimes this crack is hidden inside the shell where it cannot be seen. In many cases, movement of the insulator can be detected by hand pressure.

When you replace plugs, it is important that you select replacement plugs with the proper heat range. Check the manufacturer's manual to determine the most suitable spark plug heat range for the engine. In special cases (or when the proper plug cannot be obtained), check with your supervisor to determine which is the best plug available for the particular engine.

When you install spark plugs, always use new gaskets, if gaskets are required. A gasket performs two important functions. It maintains a gastight seal between the plug and its seat, and it conducts heat from the electrode tip to the engine block.

When you install spark plugs, use a torque wrench and tighten them to the torque specified by the engine manufacturer. If you do not seat the gasket tightly, the spark plug becomes overheated. If you flatten the

gasket too much, the shell may become distorted and damage the insulator.

ELECTRONIC IGNITION SYSTEMS.—As more modern and versatile SE is introduced into the fleet, electronic ignitions used in units employing gasoline engines have become more common. Most technicians will agree that the conventional (contact point/condenser) ignition system was the weakest link in the normally aspirated gasoline engine's dependability chain. And although transistorized ignition has been around for years, it has normally been limited to high-performance automobiles and civilian equipment. But the dependability of the electronic ignition has been proven, and it is becoming more common in support equipment.

Because conventional contact points burn easily and can handle only a limited supply of high voltages, there were disadvantages in the conventional system. If a higher primary current could be used without fear of burning the contact surfaces, then a higher secondary voltage could be induced. Early transistor ignition systems used the contact points to trigger the electronics within the module. With that design, the points were not required to carry the primary's high current flow, but they were subjected to rubbing block wear, which directly effected the saturation of the coil and the secondary ignition timing.

The transistor ignition system, shown in figures 6-54 and 6-55, is used in the JG40 shop tractor. The system is solid-state, which results in longer lasting plugs, less engine misfire under load, longer periods between tune-ups, easier starting in the fleet environment, and overall lower emissions. The ignition system is a Chrysler Corporation design, and a complete tester for the system is available through Chrysler representatives. However, the theory is relatively simple, as are the basic troubleshooting procedures.

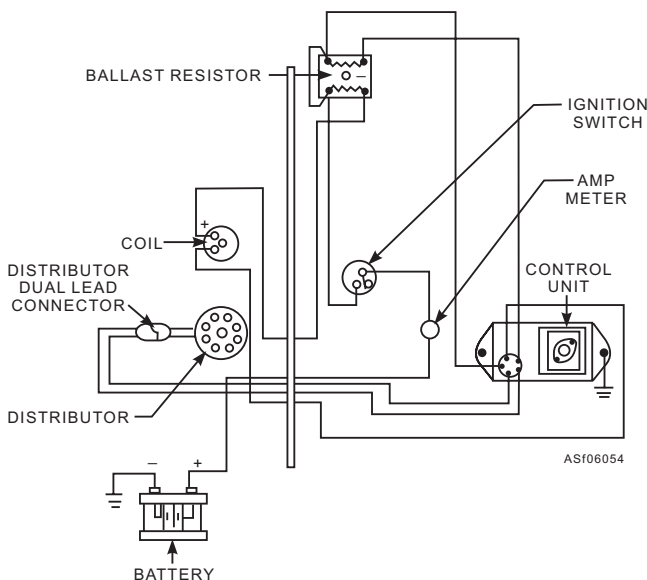

Figure 6-54.—Electronic ignition system.

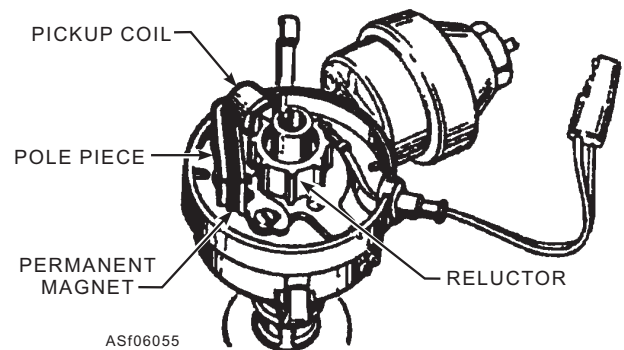

Figure 6-55.—Distributor used with transistorized ignition system.

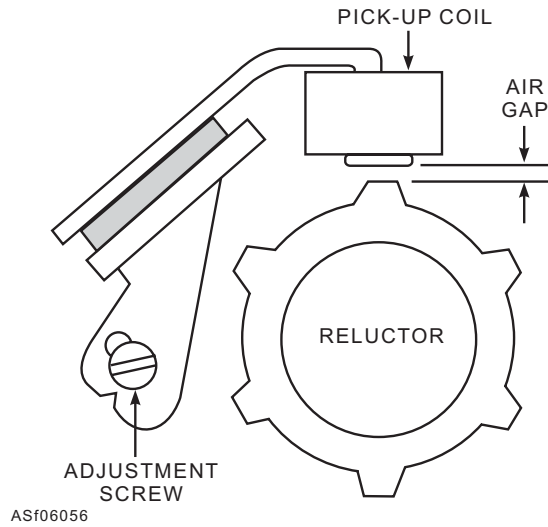

Figure 6-56.—Air gap adjustment.

You can substitute a 20,000-volt-ohmmeter that uses a 1 1/2-volt battery for the tester. To ensure your meter is in calibration, check the reluctor-to-pickup coil air gap with a .006 inch NONMAGNETIC feeler gauge. The gauge should fit snugly (fig. 6-56) without being forced. Adjust as required. Check the primary wire at the ignition coil and ballast resistor for tightness. If these checks do not alleviate the problem, the following procedures will determine if a component is faulty.

Check and note the battery reading, which should be at least 12 volts. Turn the ignition switch to the OFF position, and remove the multiwiring connector from the control unit. Turn the ignition switch to the ON position. Connect the negative lead of the voltmeter to a

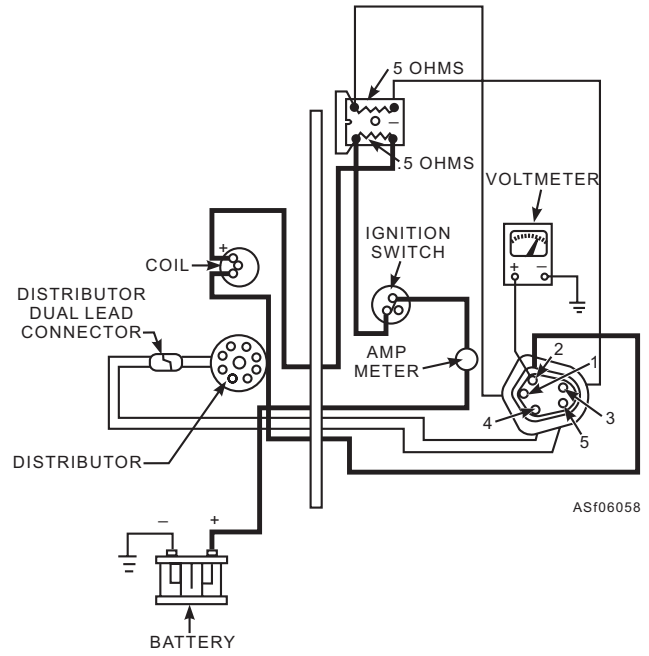

Figure 6-58.—Harness connector No. 2 test.

good ground. Connect the positive (+) lead of the voltmeter to the wiring harness connector, cavity 1 (fig. 6-57). Available voltage should be within 1 volt of battery voltage with the accessories off. If there is more than a 1-volt difference between the reading and the battery voltage, check circuit 1 (bold printed). Refer to the applicable technical manual for appropriate color-coding of wires.

Follow the same procedure when connecting positive (+) leads to cavities 2 and 3 (figs. 6-58 and 6-59). If more than a 1-volt difference occurs in either

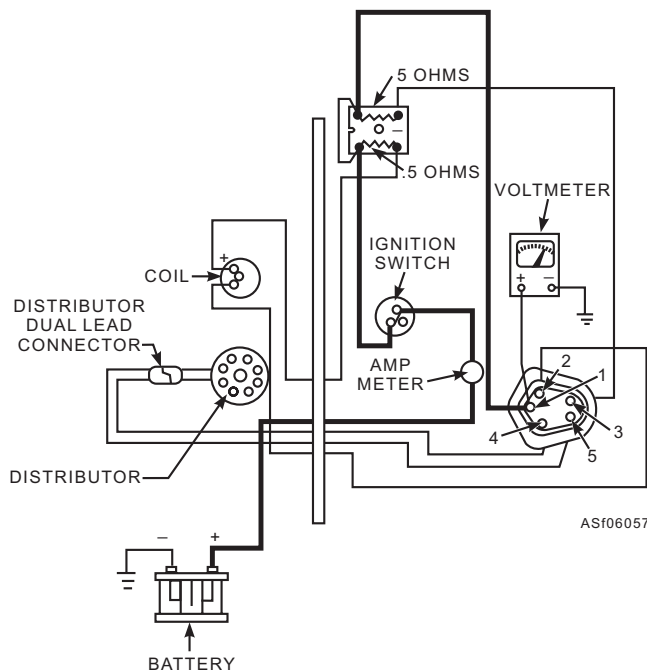

Figure 6-57.—Harness connector No. 1 test.

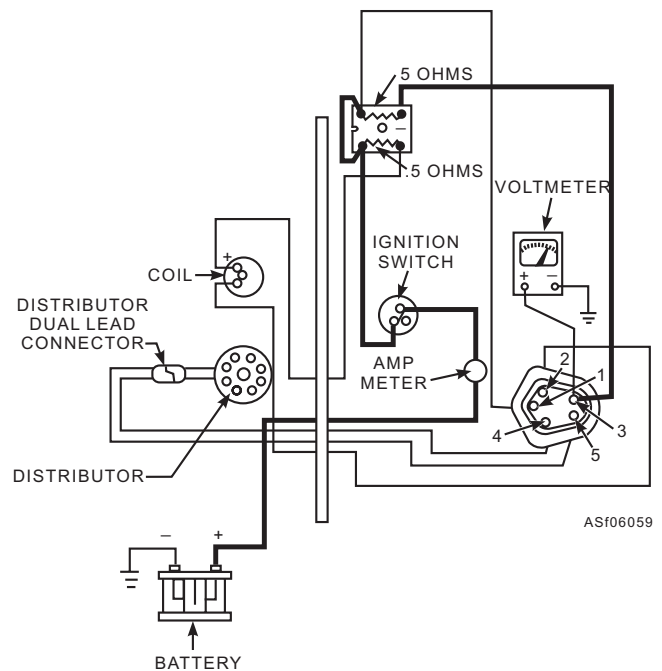

Figure 6-59.—Harness connector No. 3 test.

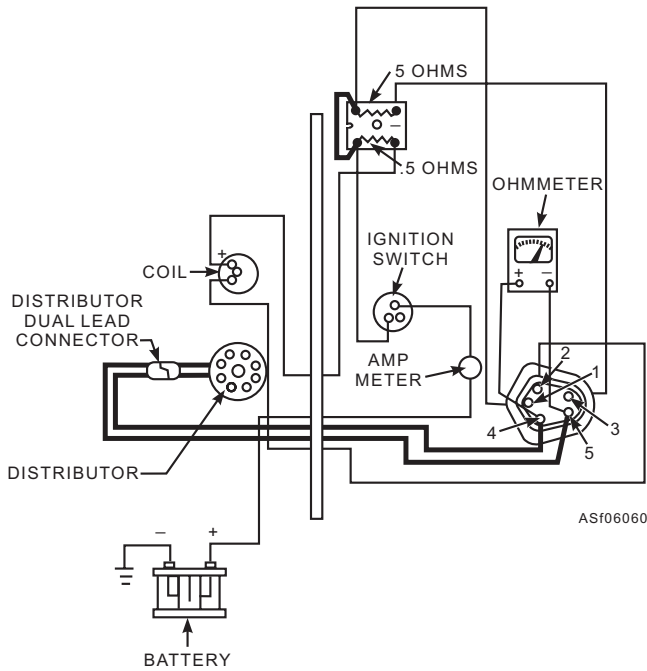

Figure 6-60.—Harness connector Nos. 4 and 5 tests.

of the tests, check the bold-printed circuit corresponding to the tested connector.

The Chrysler electronic ignition system used in tow tractors can be either a single ballast resistor/four-pin control unit or a dual ballast resistor/five-pin control unit. The dual ballast resistor/five-pin system is used here for troubleshooting even though the procedures (except the connector No. 3 test) are the same. The ballast resistor reading for the single resistor will be 1.2 ohms (instead of the 5 ohms and .5 ohm on the dual resistor).

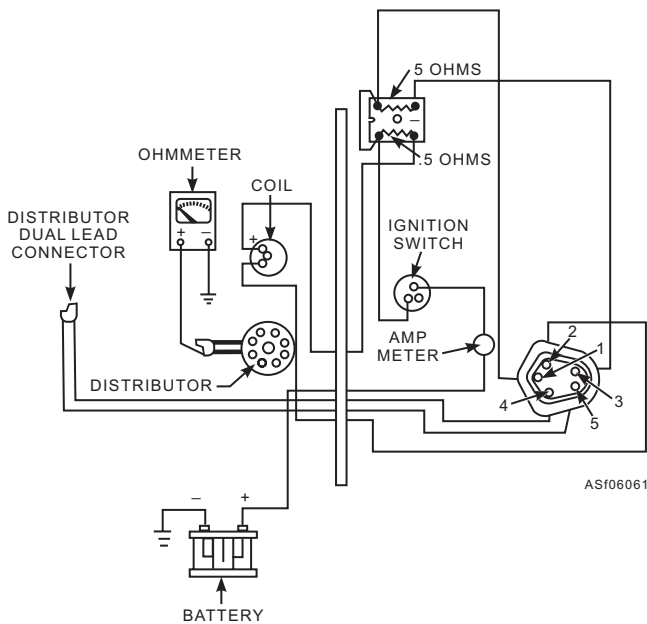

Figure 6-61.—Distributor dual lead test.

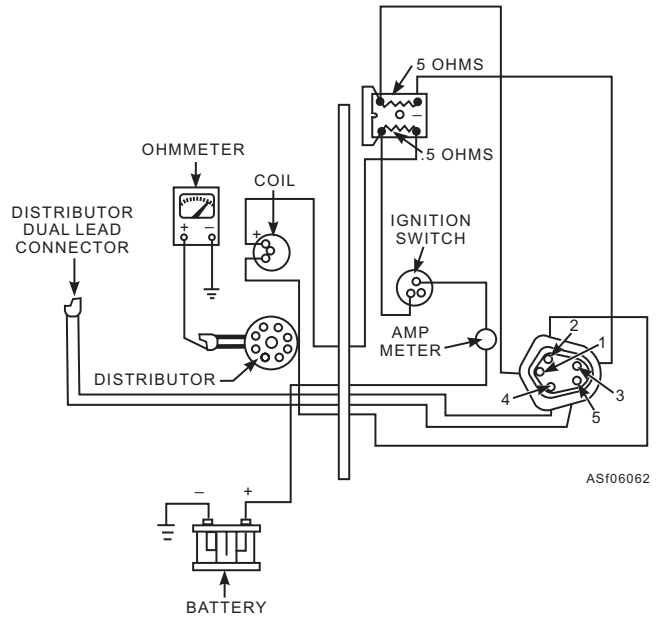

Figure 6-62.—Pickup coil ground test.

Turn the ignition off and check the distributor pickup coil by connecting an ohmmeter between wiring harness connectors Nos. 4 and 5 (fig. 6-60). The resistance should be between 150 and 900 ohms. If the reading fails, disconnect the distributor dual lead connector. Attach the ohmmeter to the connector coming from the distributor and check for resistance (fig. 6-61). If the reading is still not between 150 and 900 ohms, replace the pickup coil assembly in the distributor. Connect an ohmmeter lead to a good ground, and then take the other lead and connect it to either of the connectors on the distributor (fig. 6-62). The ohmmeter should show an open circuit. If the ohmmeter indicates a reading, replace the pickup coil in the distributor.

To check the electronic control unit ground circuit, connect one ohmmeter lead to a good ground and the other lead to the control unit's pin 5 (fig. 6-63). The

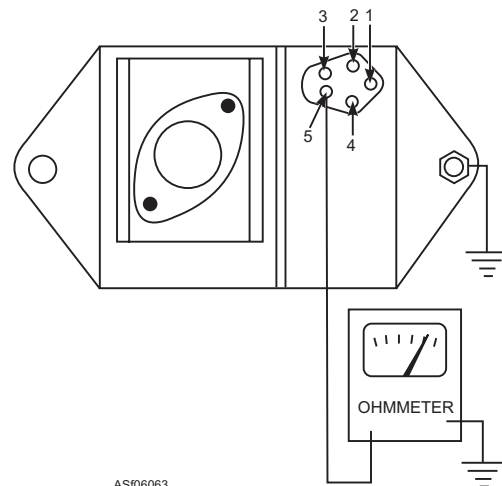

Figure 6-63.—Control unit No. 5 test.

ohmmeter should show continuity between the ground and the connector pin. If continuity does not exist, tighten the bolts holding the control unit to the firewall and recheck. If continuity still does not exist, replace the control unit. Reconnect the wiring harness to the control unit and distributor.

NOTE: When installing the wiring harness connector to the control unit, ensure the ignition switch is in the OFF position. Otherwise, the control unit could be damaged.

Check the ignition secondary system again; remove the high-voltage cable from the center tower of the distributor and hold the cable approximately 1/4 inch away from the engine (fig. 6-64). Crank the engine and check for spark. If there is no spark, replace the control unit. Crank the engine again, and if a spark still does not occur, replace the ignition coil.

SECONDARY ELECTRICAL SYSTEM TROUBLESHOOTING

The secondary system in the ignition system on modern SE consists of the high-tension lead from the coil tower to the center position in the distributor cap, the distributor cap and rotor button, the high-tension spark plug leads from their respective positions in the distributor cap to the spark plugs, and the spark plugs themselves. Troubleshooting procedures are the same for both conventional and electronic ignition systems.

Distributor Cap and Rotor

During initial troubleshooting, you have verified that the fuel system is operational, and the compression is ample for starting. A spark was observed at the coil's high-tension lead, but there was no combustion at the cylinders. If you can eliminate those factors, then the

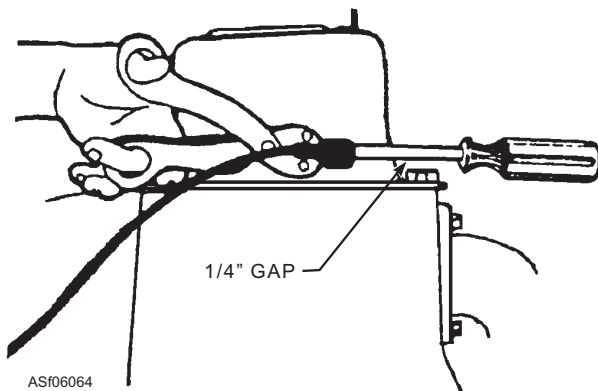

Figure 6-64.—Checking for spark at the plug.

fault must be in the spark plugs, the distributor cap, the rotor button, or the high-tension spark plug leads.

To determine where the fault lies, remove the distributor cap and inspect the metal segments that protrude through the cap from the high-tension spark plug leads and the carbon contact located directly below the cavity where the high-tension coil lead attaches. Inspect for excessively burnt or bent segments, a crack in the distributor cap, or a broken carbon contact. If observations indicate that the rotor button's contact has been hitting the distributor cap's metal segments, the distributor shaft should be checked to determine if the shaft bushings are worn. Additionally, the distributor cap should be inspected for "tracing," which is a metal powder residue running from segment to segment inside the cap.

Spark Plugs and Leads

If the distributor cap and rotor button seem to be in order, the individual high-tension spark plug leads must be checked for continuity. Since radio-resistant wires are used extensively in today's SE, the technical manuals should be consulted when checking resistance values on these high-carbon impregnated leads.

By following this "common sense" approach to troubleshooting, the secondary side of the ignition system and all problems will be covered, and the malfunction corrected.

Q6-22. What is the approximate output voltage of the ignition coil in a conventional ignition system?

1. 12 - 24 Vdc
2. 115 - 220 Vdc
3. 1000 - 1500 Vdc
4. 15,000 - 20,000 Vdc

Q6-23. The purpose to the ignition resistor (ballast resistor) is to perform which of the following functions?

1. To limit the current flow across the breaker points during low-speed operation
2. To prevent the discharge of the batteries through the primary circuit when the unit is shut off
3. To prevent arcing across the points in the primary circuit
4. To increase the current flow in the primary circuit during starting

STARTING SYSTEMS

Q6-24. Which of the following components in a conventional ignition system is designed to open the primary ignition circuit, causing the magnetic field to collapse?

1. The rotor
2. The breaker points
3. The capacitor
4. The ignition control unit

Q6-25. Which of the following components in a conventional ignition system is designed to prevent arcing across the breaker points?

1. The rotor
2. The breaker points
3. The capacitor
4. The ignition control unit

Q6-26. The timing advance is accomplished in which of the following components?

1. The breaker points
2. The capacitor
3. The distributor
4. The ignition coil

Q6-27. Which of the following is NOT an advantage of a transistorized ignition system?

1. Higher voltage at the spark plugs
2. Less battery voltage required for ignition
3. Extended breaker point life
4. Extended spark plug life

Q6-28. Which of the following is NOT a test that you can perform on the primary ignition circuit?

1. Battery-to-coil test
2. Starting ignition circuit test
3. Coil-to-ground test
4. Primary-to-secondary coil test

LEARNING OBJECTIVES: Identify the components of SE starting systems. Identify procedures for inspecting, checking, testing, and adjusting SE starting system components. Identify procedures for troubleshooting and repairing SE starting system components.

The major components of an electrical starting system are a battery, a starting motor, a switch for controlling the starter, essential wiring, and a drive unit. The drive unit transmits the power of the starting motor to the engine's flywheel ring gear.

The electrical starters used on support equipment are remotely controlled by a push-button switch or by an ignition switch that has a START position. An electric starting system that uses a remote control switch is illustrated in figure 6-65.

As a part of the drive unit, automotive equipment starters also incorporate a means of preventing the starter from being driven by the engine once the engine is started and is running under its own power.

STARTING MOTOR

A dc starting motor changes electrical energy into mechanical energy. In a motor, a current is sent through the armature and the field. The attraction and repulsion between the magnetic poles of the field and coil alternately push and pull the armature around. This rotation (mechanical energy) causes the engine to rotate.

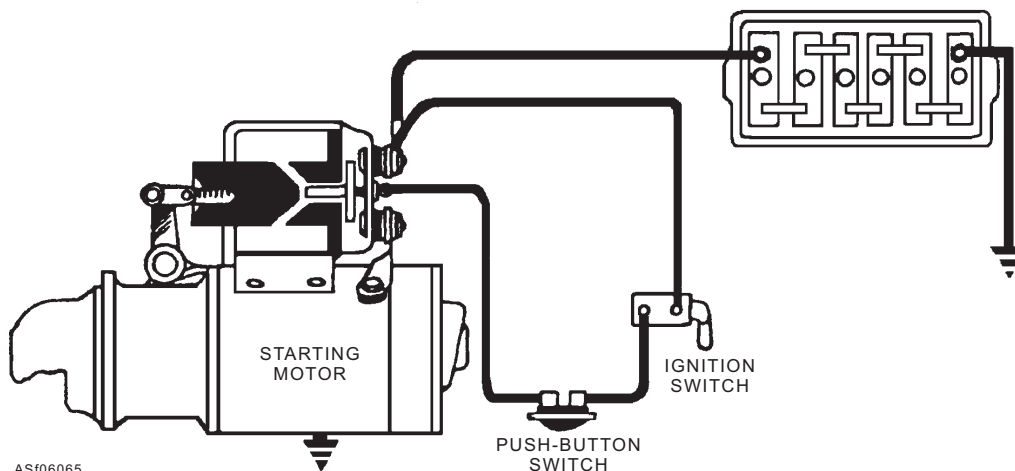

Figure 6-65.—Electric starting system.

Starting Motor Construction

A sectional view of a heavy-duty starting motor is shown in figure 6-66. This starter employs a magnetic switch to control the starter, a reduction gear driving head, and a Bendix drive. Except for the drive end and control mechanism, the general construction characteristics of the starting motor are similar to the dc generator.

The connections and arrangements of the armature coils are such that current is flowing in all the coils at the same time (series wound). This allows each coil to add its turning effort to the other coils. They work together to turn the motor armature.

The field windings are used to increase the strength of the magnetic field, and thereby increase the power of the motor. The field windings are connected in series with the brushes and armature windings. The current that flows through the field windings also flows through the armature windings. A heavy conductor is used in the field and the armature so the resistance of the motor windings is very low. This permits an extremely large current flow, and the motor develops high torque.

Types of Starter Drives

A starting motor uses a gear reduction to transmit its cranking power to the engine. The method most commonly used to obtain this gear reduction is a large diameter ring gear on the engine flywheel and a pinion gear of much smaller diameter on the starting motor armature shaft. In operation, the pinion engages and drives the ring gear, which turns the engine. The ratio between the pinion and ring gear is different on engines of different sizes and horsepower. It is usually between 10:1 and 16:1. The starting motor armature revolves 10 to 16 times for each revolution of the engine flywheel. When the pinion is engaged with the ring gear, the starting motor turns 2,000 to 3,000 rpm. This turns the engine at speeds up to 300 rpm. During operation, the engine may reach speeds of 3,000 to 4,000 rpm. If the pinion should fail to disengage from the ring gear after the engine is started, the starting motor could be rotated by the engine at speeds up to 64,000 rpm. This high a speed throws the windings from the slots in the armature and the segments from the commutator. To prevent this, various methods of engaging and disengaging the pinion with the ring gear have been devised.

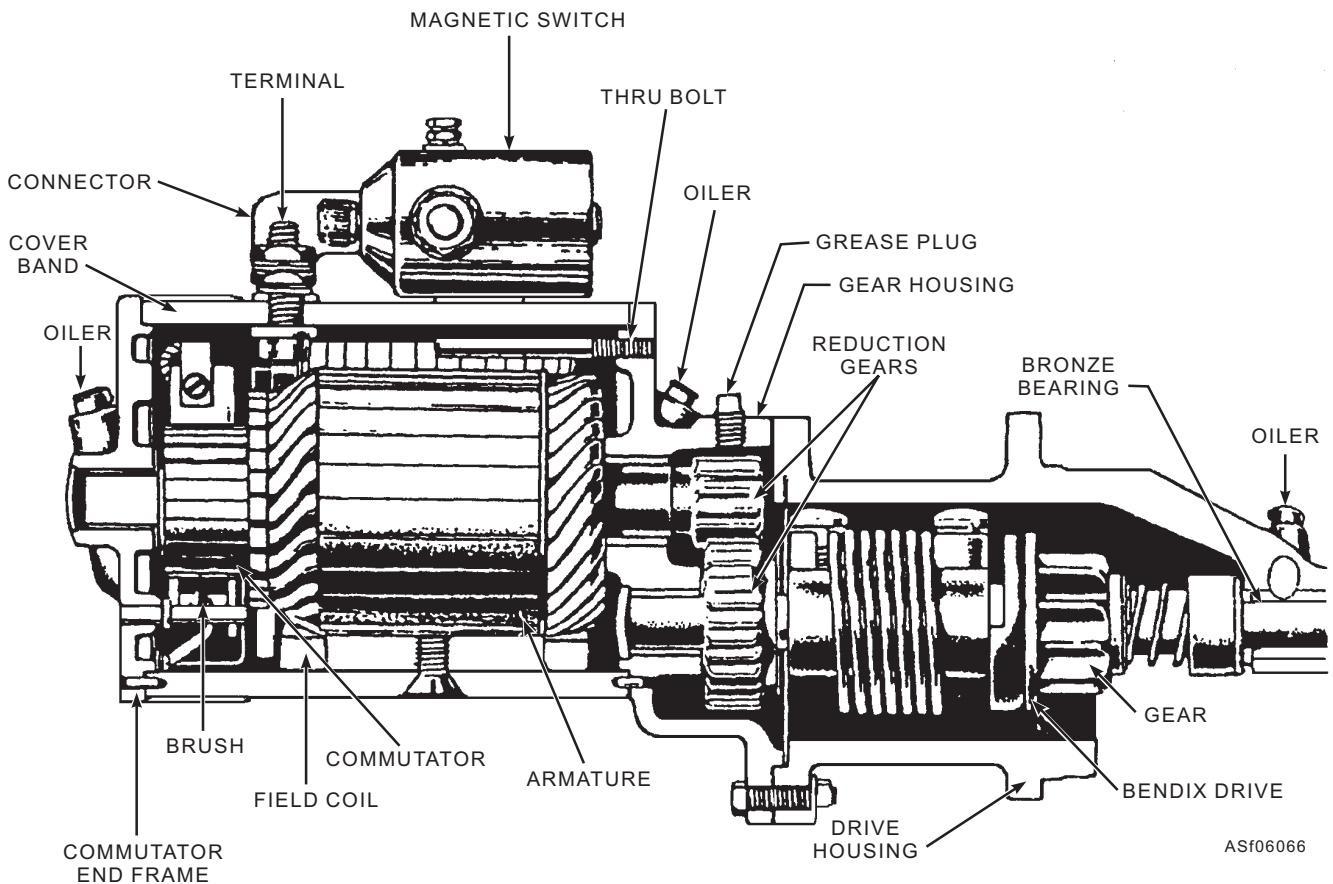

Figure 6-66.—Sectional view of a heavy-duty starter.

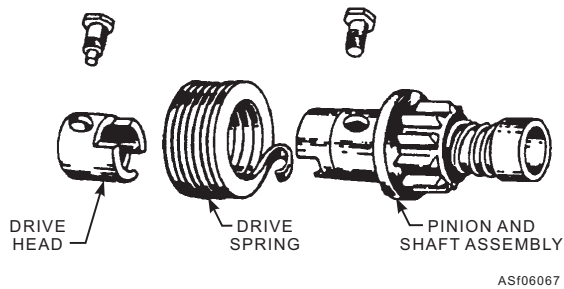

Figure 6-67.—Bendix drive construction.

BENDIX DRIVE.—This type of drive consists of a pinion and sleeve (shaft) assembly, a drive spring, and a drivehead (fig. 6-67). The pinion is counter weighted on one side and has internal spiral threads. The pinion is mounted on a sleeve and has external threads that match those of the pinion. The sleeve is a loose fit on the motor armature shaft. One end of the sleeve is bolted to the drive spring and the other end of the drive spring is bolted to the drivehead. The drivehead is keyed and bolted to the armature shaft by the shank of the same bolt that holds the drive spring to the drivehead.

When the starter is not operating, the pinion is disengaged and away from the ring gear. When the starting motor is energized, the armature immediately starts to rotate at high speed. The pinion does not rotate

immediately with the armature shaft. It remains stationary for a time because of the inertia of the counterweight, and then runs along the revolving threaded sleeve until it engages the ring gear. Should the pinion meet but not engage the ring gear, the drive spring is compressed. This allows the pinion to turn and engage the ring gear.

When the pinion and ring gear are engaged, the pinion is driven by the starting motor through the drive spring and turns the engine. The drive spring compresses to absorb the shock of initial pinion engagement and cushions the starter drive against the compression of the engine as the engine is being turned. When the engine fires and runs on its own power, the ring gear drives the pinion at a higher speed than the starting motor, and the pinion runs back along the threaded sleeve to its original, disengaged position. There are several other versions of Bendix drives in use, but they all operate on the same principle and have essentially the same construction.

OVERRUNNING CLUTCH.—The overrunning clutch drive consists of a shaft collar, a clutch spring, a shell and sleeve assembly, a pinion, a clutch rotor, and a set of rollers (fig. 6-68). The shell and sleeve assembly

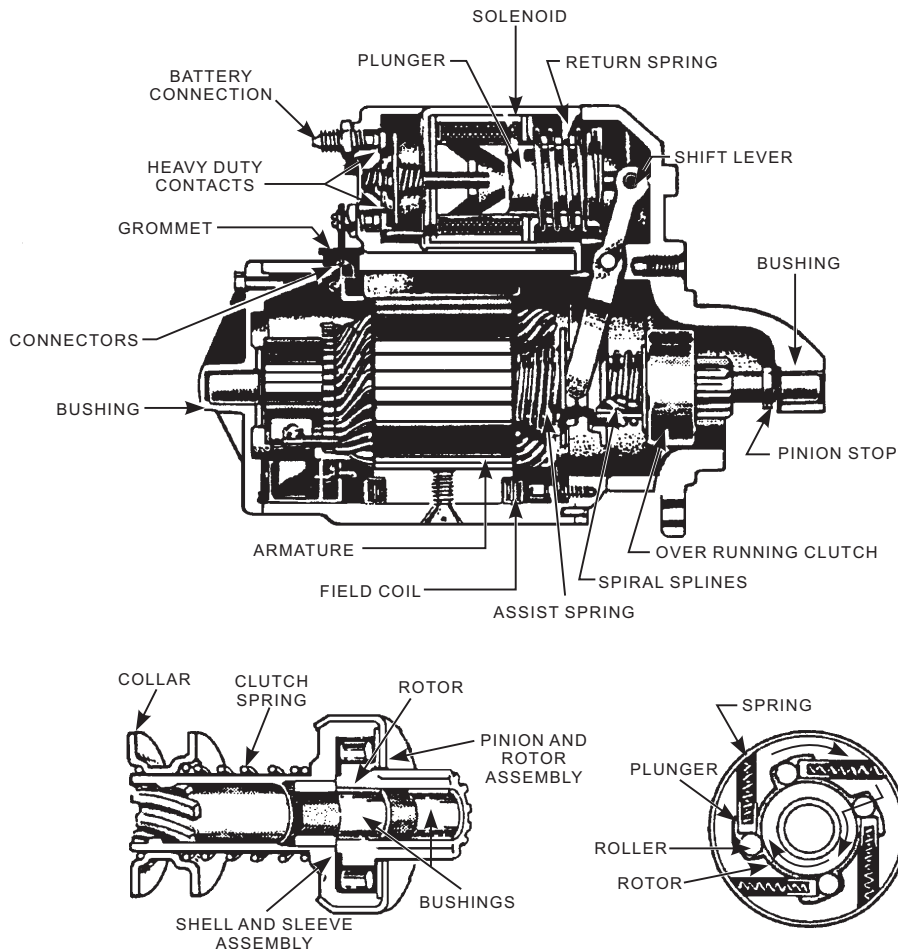

Figure 6-68.—Solenoid shift starter and overrunning clutch drive.

has internal splines and is a loose fit on the external splines of the starting motor armature shaft. The rotor is connected to the pinion and the steel rollers are located in tapered notches in the shell. Springs and plungers hold the rollers in the position shown in the illustration.

When the solenoid is energized, the drive unit is moved along the armature shaft, and the pinion engages the ring gear. Should the pinion meet the ring gear but not engage it, the clutch spring compresses; this allows the solenoid plunger to continue moving to close the contacts and energize the starting motor. As the starting motor starts to rotate, the pinion turns and is engaged with the ring gear by the action of the clutch spring expanding. The rotor is not stationary. As the starting motor rotates the shell, the rollers are forced tightly into the small end of the tapered notches to cause the shell and rotor to rotate together as a unit. The rotor is connected to the pinion, which turns the engine. After the engine begins to run, the ring gear drives the pinion at a higher speed than that of the starting motor and tends to work the rollers back toward the large end of the tapered notches against the springs and plungers. This frees the rotor from the shell and the pinion overruns the starting motor armature shaft, which prevents the starting motor from being driven by the engine even though the pinion is still engaged with the ring gear. When the solenoid de-energizes, a spring returns the drive unit back to its original position, disengaging the pinion from the ring gear.

GEAR REDUCTION DRIVEHEADS.—Gear reduction driveheads provide a greater gear reduction than that of a pinion and ring gear. They are used in conjunction with Bendix drive units on heavy-duty starters. The gear on the armature shaft does not engage directly with the ring gear. It engages an intermediate gear, which drives the starter pinion. This drive permits the use of a small starting motor, which runs at high speed to provide additional starting torque and greater cranking power. The armature of a starter of this type may turn as many as 40 times for each revolution of the flywheel when cranking an engine.

Starting Motor Controls

Starting motor controls can be divided into two groups: operating and safety. The operating controls provide the operator with the means to start the vehicle's engine. The safety controls prevent the starter from being operated under conditions that could damage the starter or vehicle.

Several types of operating and control systems exist. Those discussed in this course are widely used but none describes a specific support unit.

Solenoid

On starters that have overrunning clutch drives, a solenoid is used to shift the pinion into engagement with the ring gear (fig. 6-69). It also closes a set of heavy-duty contacts to complete the circuit from the battery to the starting motor. Mechanical linkage is used to connect the solenoid plunger to the shift lever, which moves the pinion. Remote control of the solenoid is achieved by a low current control circuit. Some systems use a push-button switch or an ignition switch with a start position. In some systems a relay is used to control current flow to the solenoid, and the remote control circuit is used to control the relay. When the control circuit to the solenoid is completed, a path for current flow is created through the pull-in and the hold-in windings. The combined magnetic fields of these windings pull the solenoid plunger in so that the pinion shifts engage the ring gear and close the heavy-duty contacts of the solenoid.

While different size wire is used for the two windings, they have approximately the same number of turns. The heavy pull-in winding is needed to pull the

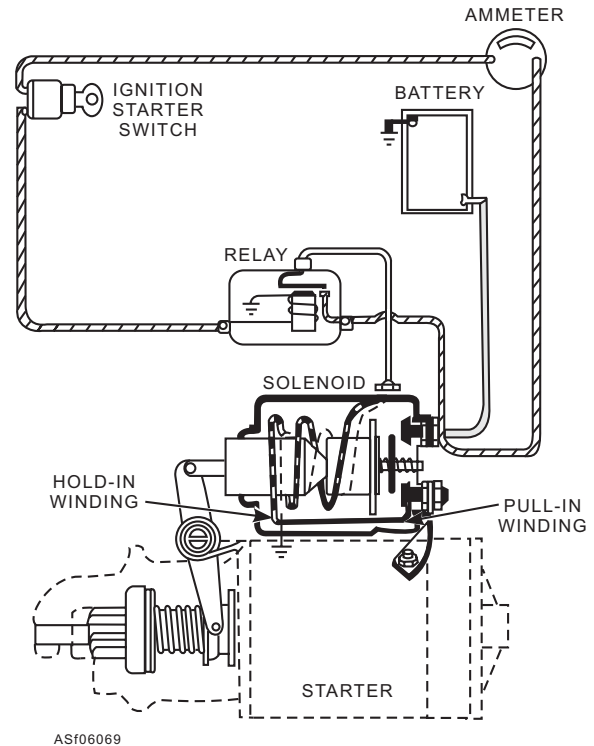

Figure 6-69.—Control system for a starter with overrunning clutch drive.

plunger in, but once the plunger movement is complete, the hold-in winding is sufficient to hold the plunger in. The pull-in winding is grounded through the very heavy winding of the starting motor. Closing the solenoid contacts completes the power circuit to the starting motor, and, at the same time, shorts out the pull-in winding.

When the ignition starter switch opens, current flow through the control circuit stops and opens the relay. However, the circuit through the hold-in winding is still completed through the pull-in winding and the closed heavy duty contacts. Current flow through the hold-in winding is in the same direction as when the control circuit was closed, but current flow through the pull-in winding is now in the opposite direction. With the same number of turns in both windings and the same current, the magnetic fields produced are equal but opposite and counteract each other. The plunger releases and returns by spring tension to its original position. This opens the heavy duty contacts and breaks the power circuit to the starting motor.

Relay

A heavy duty relay is used with a starter that has a Bendix drive (fig. 6-70). The purpose of the relay is to complete the power circuit between the battery and the starting motor. The relay is controlled by a low-current remote circuit, which has a push-button switch or an ignition switch with a start position.

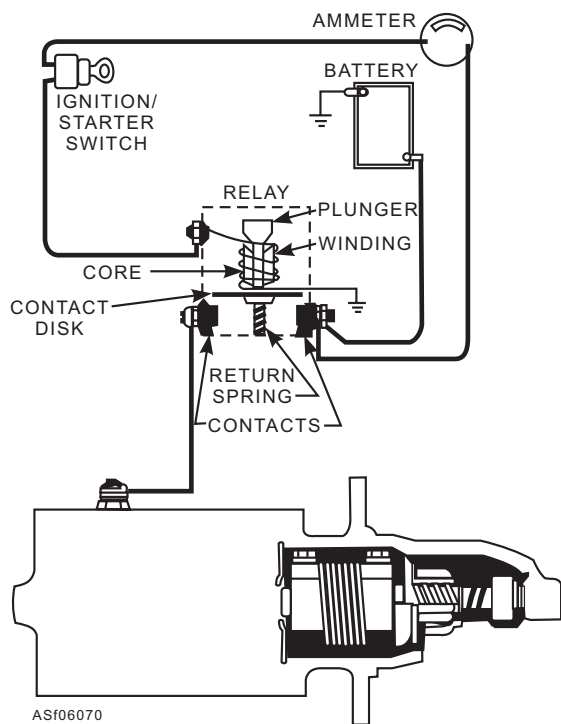

Figure 6-70.—Control system for a starter with a Bendix drive.

When the control circuit to the relay closes, it creates a path for the current flow through the relay winding. The magnetic field produced pulls the plunger in and closes the heavy duty contacts. This energizes the starting motor. When the control circuit opens, current flow through the relay winding stops and the magnetic field collapses. The plunger releases and returns to its original position by the return spring. This opens the contacts and breaks the power circuit to the starting motor.

Safety Controls

Safety controls are incorporated in support equipment starting systems to prevent engagement of the starter after the engine is running. On self-propelled equipment, a safety control prevents the vehicle's engine from starting unless the transmission shifter lever is in a nondrive position (neutral or park). Two examples are shown in figure 6-71.

The safety devices discussed here may be used in any combination desired by the manufacturer. Reference must be made to the applicable maintenance manuals for the particular unit before you attempt to troubleshoot or repair a starter control system.

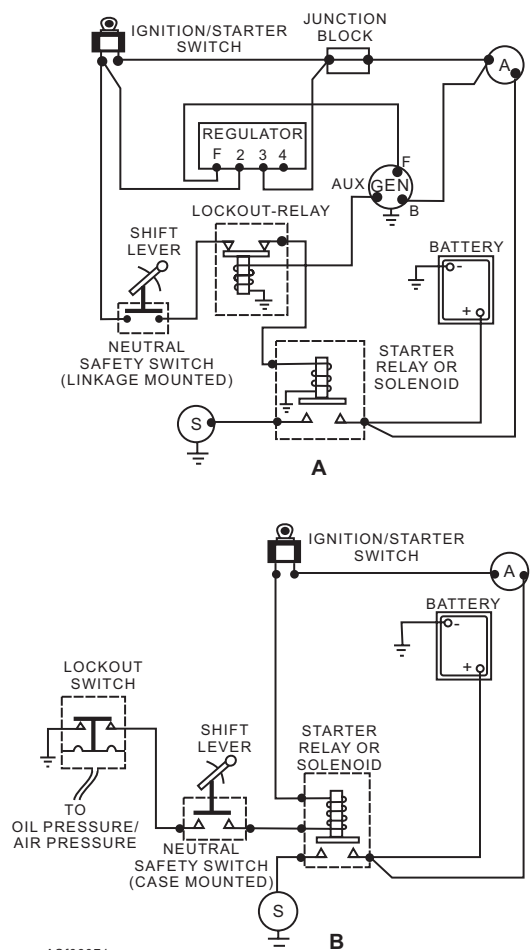

Figure 6-71.—Starter safety control combinations.

All support equipment with automatic transmissions have some form of a neutral safety switch to eliminate the possibility of the engine starting with the transmission selector lever in a position to drive the vehicle.

The switch is mounted on the transmission shift linkage or on the transmission case. When it is mounted on the transmission shift linkage, it is connected in series with the starter switch and the starter relay or solenoid windings. When it is mounted in the transmission case, it is connected in series with the starter relay or solenoid winding and ground.

The shift lever actuates the switch. The switch is open in all lever positions except neutral and park.

Starter Lockout Relay

This system is used to prevent the starter from being energized when the engine is running.

The normally closed contacts of the lockout relay connect in series with the starter switch and the starter relay or solenoid winding. One end of the lockout relay winding connects to the output of the generator; the other end is to ground. When the generator output voltage reaches a value great enough to energize the lockout relay, the lockout relay contacts open. This opens the control circuit to the starter relay or solenoid winding. The contacts of the lockout relay remain open as long as generator output voltage is equal to or above that required to energize the lockout relay. Connection to generator output voltage is made at the generator so that operation of the lockout relay is not dependent upon operation of the generator regulator.

When the engine is shut down, the contacts of the lockout relay return to the closed position as generator output voltage drops to a value below that required to energize the relay.

Starter Lockout Switch

This device is used for the same purpose as the starter lockout relay—to prevent the starter from being energized when the engine is running. The switch is actuated by engine oil pressure, except when used with a two-stroke cycle diesel engine, when it is actuated by air pressure from the collector box of the engine blower.

The diaphragm-operated lockout switch contacts are connected in series with the starter relay or solenoid winding and ground. After you start the engine, oil or air pressure builds up sufficiently to move the diaphragm (usually 10 to 15 psi of oil pressure or 2 to 3

inches of water gauge air pressure). The switch contacts open, interrupting the circuit between the winding of the starter relay or solenoid and ground.

When you shut the engine down, the contacts of the lockout switch return to the closed position as oil or air pressure decreases to a value below that required to actuate the lockout switch.

MAINTENANCE AND REPAIR

The starting system requires little maintenance if used properly. If a malfunction does occur, you must know how to troubleshoot the system and correct the malfunction.

When the starter cranks the engine slowly (or not at all), tests must be made to determine whether the malfunction is in the battery, starting motor, circuit wiring, or some other component of the system. Many conditions besides defects in the starting motor can result in poor starter performance.

Prior to making any test, visually inspect the complete system. Ensure that all connections are clean and tight, that the wiring is not frayed or otherwise damaged, and check to determine that the starter mounting bolts are tight.

There are many methods that can be used to test starting systems to determine their condition. Some of these methods require the use of test equipment that may not be available to you in fleet units. With this in mind, the tests presented here are such that they may be performed using a minimum of test equipment.

Battery Capacity Test

Remember that the starting system is completely dependent upon the battery for operation. Troubleshooting the starting system must begin with the battery. Specific gravity and open circuit voltage readings provide a general indication of battery condition. A more accurate indication can be obtained by making a capacity test. Use a battery-starter tester for this purpose.

NOTE: If the specific gravity of the battery is 1.220 or less, do not attempt to make a capacity test. The battery must be removed and slow-charged until fully charged before testing.

To make a capacity test, the ampere-hour rating of the battery must be known. This is generally stamped on the battery case. If it is not, refer to the manufacturer's instruction manual for the particular equipment.

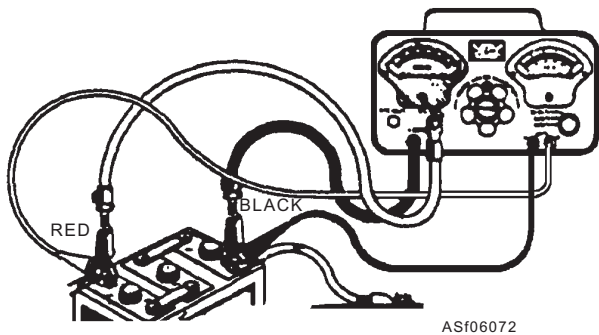

Figure 6-72.—Tester connections for a battery capacity test.

Set the tester voltmeter scale selector switch to a scale position higher than the voltage of the battery to be tested; set the load control knob of the tester to the OFF position.

WARNING

If connection to the battery is made with the load control in any position other than OFF, severe arcing may occur at the battery posts. If this happens, a battery explosion with injury to personnel is a possibility.

Connect the battery-starter tester as shown in figure 6-72. Turn the load control knob clockwise until the

ammeter reading is three times the ampere-hour rating of the battery. An example is 180 amperes for a 60-ampere-hour battery. With the tester ammeter reading the specified load for 15 seconds, note the voltmeter reading. A reading of 9.5 volts or more for a 12-volt battery and 18.5 volts for a 24-volt battery indicates ample capacity.

Voltage Drop (Resistance) Tests

High resistance or an open circuit in the starting system can be located by using an accurate, expanded-scale voltmeter to check the voltage drop across various points.

If the vehicle to be tested is gasoline powered, remove the ignition coil high-tension lead from the distributor and ground it (standard ignition), or ground the primary distributor terminal of the coil (transistorized ignition) to prevent the engine from starting while you are making the voltage drop tests.

NOTE: The voltage readings (drops) used here are general averages and are not to be used in place of the vehicle manufacturer's specifications.

The following six tests are used to test starting systems equipped with solenoid-operated overrunning clutch-type starters (fig. 6-73).

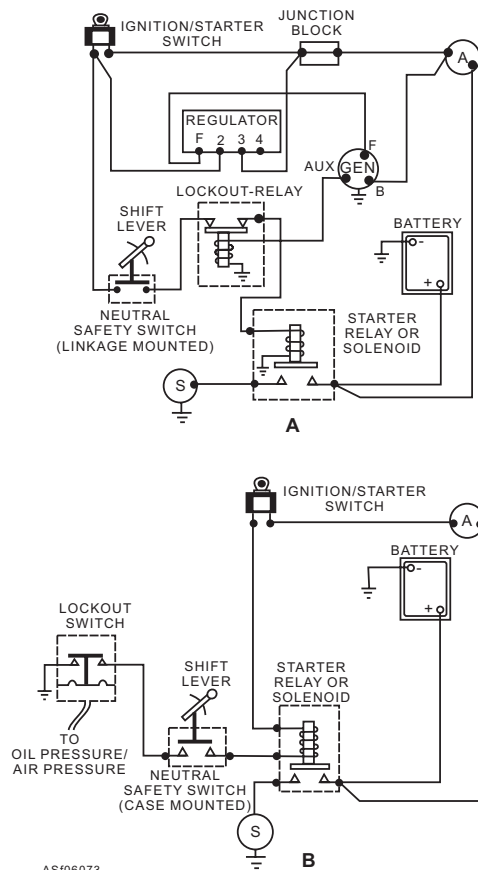

Figure 6-73.—Voltmeter connections for checking starting system circuit resistance.

CAUTION

Do not operate the starting motor for an extended length of time, as it can be severely damaged by overheating. Operate the starter for a maximum of 30 seconds, and then allow it to cool for 2 minutes before you resume cranking.

TEST 1.—With the voltmeter leads connected between the battery's positive post and the starting motor terminal, attempt to crank the engine. Voltage reading (drop) should not exceed 0.5 volt. If the drop exceeds 0.5 volt, the high resistance is in the starting system rather than the starting motor. If the drop does not exceed 0.5 volt, perform test 4 to determine if the high resistance is in the starting motor or in the starting motor ground circuit.

TEST 2.—With the voltmeter leads connected between the battery's positive post and the battery terminal of the solenoid, attempt to crank the engine. Voltage drop should not exceed 0.1 volt. If the drop exceeds 0.1 volt, the high resistance is in either the battery cable connections or the battery cable between these test points.

TEST 3.—With the voltmeter leads connected between the battery's positive post and the starting motor terminal of the solenoid, attempt to crank the engine. Voltage drop should not exceed 0.5 volt. If the drop should exceed 0.5, the high resistance is in the solenoid. Either its contacts are burned or they are not closing.

TEST 4.—With the voltmeter leads connected between the battery's negative post and the starting motor frame, attempt to crank the engine. Voltage drop should not exceed 0.1 volt. If the drop exceeds 0.1 volt, the high resistance is in the ground circuit between the battery and the starting motor (ground cable, cable connections, or starter mountings). If the voltage drop does not exceed 0.1 volt, the starter must be removed for further testing.

TEST 5.—With the voltmeter leads connected between the battery's negative post and the solenoid switch terminal, attempt to crank the engine. Available voltage should not be less than battery voltage. If a reading lower than this is obtained, the high resistance is in the starter switch circuit (neutral safety switch, connections, or wiring). If correct voltage is indicated and the solenoid does not operate, perform test 6. If the solenoid is grounded internally, the starter must be removed for further testing.

CAUTION

Before performing test 5, the voltmeter scale selector switch must be set to a scale position above battery voltage to prevent damage to the voltmeter.

TEST 6.—With the voltmeter leads connected between the battery's negative post and the ground terminal of the solenoid, attempt to crank the engine. Voltage drop should not exceed 0.1 volt. If the drop exceeds 0.1 volt, the high resistance is in the solenoid ground circuit (wiring, connections, neutral safety switch, or starter lockout devices).

If the results of tests 5 and 6 on a solenoid-operated, overrunning-clutch starter system are within limits and the solenoid does not operate, the starter must be removed for further testing. The test procedure and the maximum allowable voltage drop is the same for the relay-operated starter system.

Q6-29. What is the purpose of the starter motor?

1. To rotate the cam shaft
2. To convert ac alternator output to dc current for engine cranking
3. To change electrical energy to mechanical energy
4. To change mechanical energy to electrical energy

Q6-30. Which of the following methods does a starter motor use to transmit its cranking power to the engine?

1. Electromotive force
2. Electromechanical force
3. Gear compensation
4. Gear reduction

Q6-31. Which of the following components is designed to prevent the starter motor from being driven by the engine after the engine has been started?

1. The starter lock-out relay
2. The overrunning clutch
3. The overspeed clutch
4. The kick-out gears

Q6-32. On starters that have overrunning clutch drives, what purpose does a solenoid serve?

1. To prevent excessive current flow to the starter
2. To shift the starter pinion into engagement with the ring gear
3. To boost current flow for turning the starter.
4. To disengage the starter pinion from the ring gear

Q6-33. In an item of SE with an automatic transmission, which of the following components, will prevent the engine from starting with the transmission select lever in a position to drive the vehicle?

1. The neutral safety switch
2. The shifter safety switch
3. The forward/reverse safety switch
4. The park/drive safety switch

Q6-34. When used with a two-stroke cycle diesel engine, which of the following components actuates the starter lockout switch?

1. Engine oil pressure
2. Engine fuel pressure
3. Engine water temperature
4. Engine blower air pressure

Q6-35. You should not attempt to make a capacity test if the specific gravity reading is less than which of the following readings?

1. 1.220 or less
2. 1.120 or less
3. 1.100 or less
4. 1.000 or less

ACCESSORIES

LEARNING OBJECTIVES: Identify procedures for inspecting, checking, testing, and adjusting SE electrical accessories. Identify procedures for troubleshooting SE electrical accessories. Identify procedures for repairing, removing, and replacing SE electrical accessories.

What is an automotive accessory? On support equipment it is not an AM/FM stereo radio or electric

windows, as on your car. Here we refer to gauges and meters that relay vital information. Support equipment accessories also include safety and comfort accessories, such as turn signals, horns, windshield wipers, and electric fans. All of this equipment is electrically operated.

The need for automotive accessories has increased dramatically over the last decade. Accessories allow you to monitor the operation of a unit. The readings taken from the gauges and meters can warn you of malfunctions or impending failure. Some required preventive maintenance is scheduled according to the readings on hour meters and start meters.

As a Support Equipment Technician, you are responsible for maintenance and repair of the automotive accessories. On some vehicles, this may seem to be a difficult task; but the mystique is easily removed by referring to the manufacturers' manuals. The schematics and narratives on each system are written in sufficient detail so you can easily understand them.

INSTRUMENT ACCESSORIES

The instrument accessories are usually placed on a panel so they can be easily read by the operator. They inform the operator of the approximate speed, engine temperature, oil pressure, rate of charge or discharge of the battery, amount of fuel in the fuel tank, distance traveled, and the time. Certain controls are frequently mounted on the instrument panel, such as the throttle, choke, starter switch, heater, and windshield wipers.

Ammeter

The typical automotive ammeter (fig. 6-74, view A) contains a steel armature mounted on the same shaft

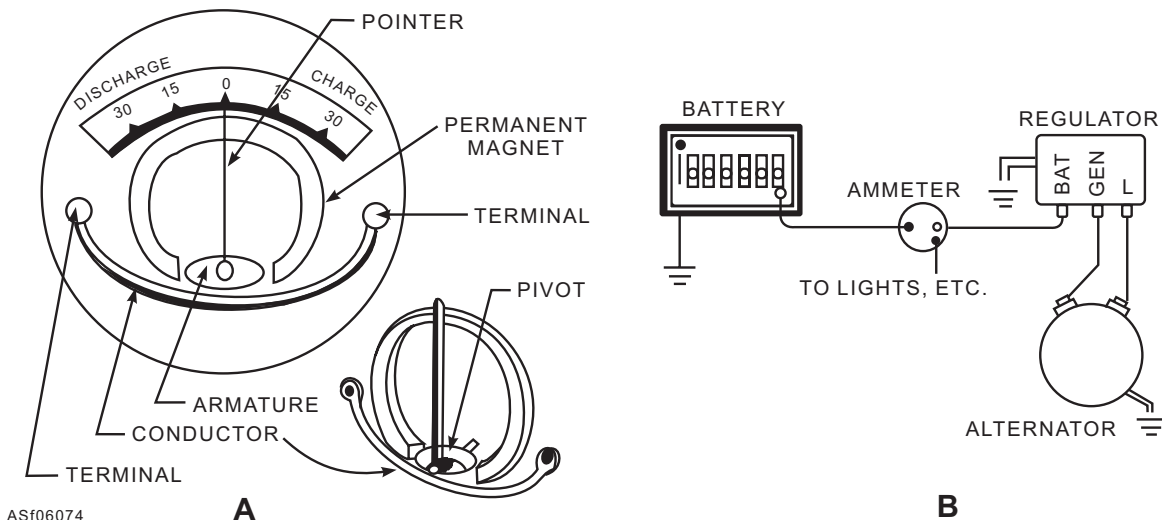

ASf06074

Figure 6-74.—(A) Simplified automotive ammeter; (B) Wiring diagram showing ammeter in the charging circuit.

as the pointer. With no current flowing through the ammeter, the permanent magnet holds the armature so that the pointer indicates zero.

When current flows, it produces a secondary magnetic field that opposes the magnetic field of the permanent magnet. Therefore, the secondary magnetic field acts on the pointer shaft, causing it to deflect so that the pointer moves away from zero.

The amount of deflection is determined by the strength of the secondary field, which is determined by the strength of the current flow through the ammeter. When the current flow in figure 6-74, view B, is from the battery to the lights, a discharge will show on the ammeter. When the generator output voltage exceeds that of the battery, the generator will provide the current to operate the lights. It will also be charging the battery. The charging current will cause the ammeter indicator needle to deflect toward the charge scale.

NOTE: The ammeter is connected so that current from the battery to the starting motor does not flow through the ammeter when the vehicle engine is started. The starting motor may draw several hundred amperes during starting, and the range of the ammeter would be greatly exceeded.

Fuel Gauge

Most fuel gauges are electrically operated and are composed of two units—the gauge mounted on the instrument panel and the sending unit mounted in the fuel tank. The ignition switch is included in the fuel

gauge circuit so that the electrical fuel gauge operates only when the ignition switch is on. Operation of the electrical fuel gauges depends on coil (magnetic) or thermostatic (bimetallic) action.

COIL-OPERATED FUEL GAUGE.—The electrical circuit for a coil-type fuel gauge is shown in figure 6-75.

Current from the battery has parallel paths of flow through the rheostat of the sending unit and the operating coil of the gauge. The parallel paths join at the common connection between the two coils of the gauge. Current flows through the limiting coil, ignition switch, ammeter, and back to the battery.

Fuel level indications result from variations in the magnetic fields of two coils. The rising or falling float in the fuel tank moves the arm of a rheostat (variable resistor), causing the magnetic fields to vary in the coils when the tank is full, and the sending unit float will be at the upper position. This will present maximum resistance at the top between the limiting coil and the operating coil. Maximum current flow will be through both coils. The operating coil becomes dominant, which draws the pointer to the “full” position.

As the fuel level drops, the sending unit float level also drops. This lowers the resistance of the sending unit. With less resistance, more current flows through the limiting coil and less through the operating coil. The magnetic attraction of the limiting coil is becoming dominant, drawing the pointer toward the “empty” side of the scale. The further the float falls, the less

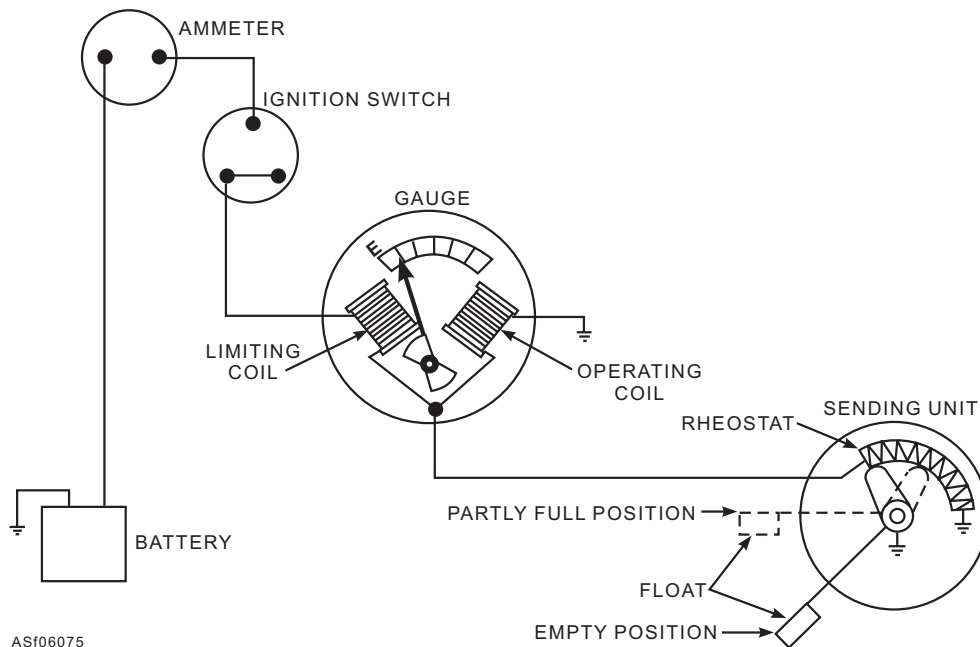

Figure 6-75.—Coil operated fuel gauge circuit.

resistance in the sending unit. When the float reaches the bottom, the sending unit presents a near zero resistance. This provides a maximum current flow through the limiting coil and little through the operating coil. The limiting coil draws the pointer to the totally empty position.

This type of gauge consumes very little current, about one-eighth of an ampere. Since the operation of this gauge depends on the difference in the magnetic effect between two coils, variations in the battery voltage will not cause an error in the gauge reading.

THERMOSTATIC FUEL GAUGE.—The thermostatic electrical fuel gauge has bimetal blades in the gauge and the sending unit. This type of gauge may also be used as a temperature or oil pressure gauge by using changes in temperature or pressure to operate the movable grounded contact in the sending unit.

When the tank is empty and the float is down, as shown in view A of figure 6-76, the two contacts in the sending unit are just touching. Current flows through the resistance heater wires of both gauge and sending units, causing the bimetal blades to bend. Bending of the bimetal blade in the sending unit separates the contacts to break the circuit. The heater wire cools when the current stops flowing, and the bimetal blades return to their original position. Contact is again made, and the cycle of operation is repeated approximately every second. Opening and closing of the contacts produces an intermittent flow of current, which does

not heat the gauge blade sufficiently to bend it, and the blade holds the pointer at the empty reading.

When the tank is full, the float is at the top and the cam takes the position shown in view B of figure 6-76. In this position, the cam pushes the grounded contact against the insulated bimetal contact, bending the bimetal blade in the sending unit. Since the bimetal is then under a strain, the current must flow longer to bend it sufficiently to open the contacts. The longer flow of current causes a bending of the bimetal blade in the gauge unit, pushing the pointer over to the full position.

The contacts open and close fast enough to give a steady reading by the pointer. The maximum current requirement for a full reading is less than one-fourth ampere. This type of gauge is not affected by variations of battery voltage, and is compensated for outside air temperature variations.

Oil Pressure Gauge

The oil pressure gauge indicates the oil pressure in the system. Usually, such gauges are mounted on the instrument panel and are calibrated to read oil pressure in pounds per square inch.

BOURDON TUBE OIL PRESSURE GAUGE.— Bourdon tube oil pressure gauges are actuated by the pressure of air trapped above the oil in a very small copper tube connected from the gauge to the lubricating system. Air pressure in the connecting tube

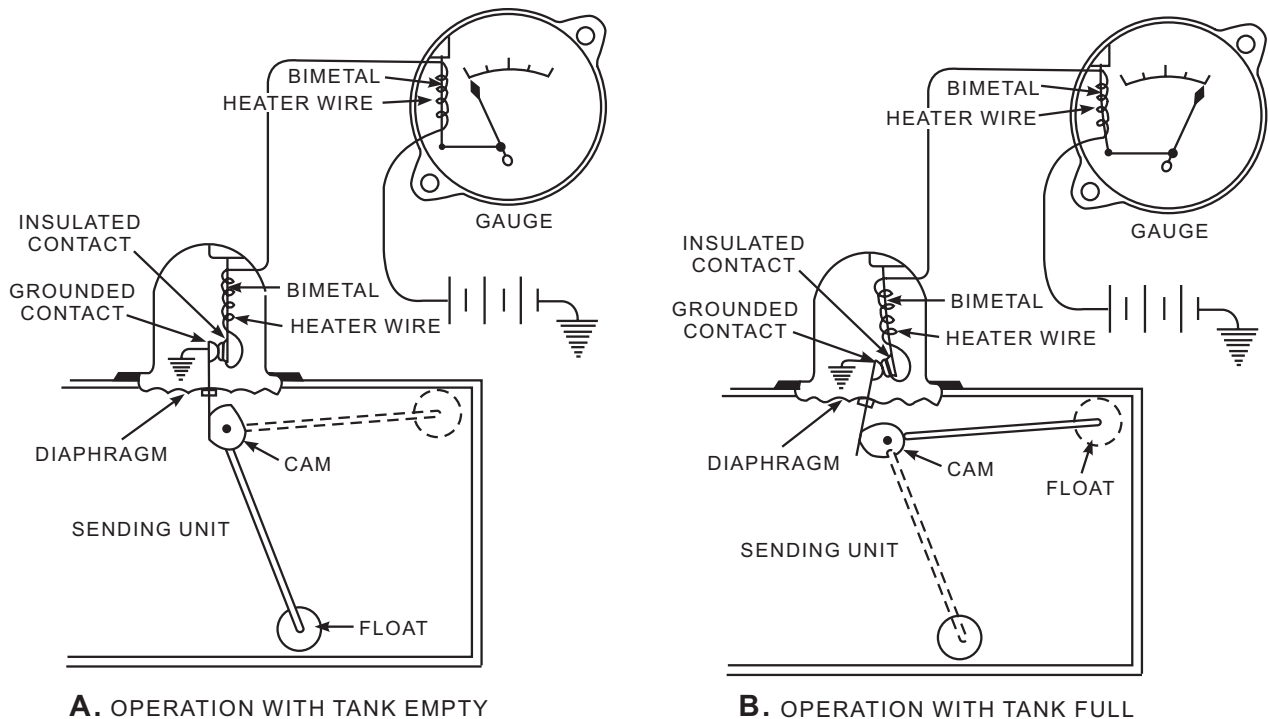

ASF06076

Figure 6-76.—Thermostatic fuel gauge circuit.

is maintained by the oil pressure in the system. Operation of the gauge itself is based on the use of the Bourdon tube (fig. 6-77), which is a flexible, semicircular metal tube, elliptically shaped in cross section, with one sealed end and one open end. The open end is connected to the pressure system. As the pressure of gas or liquid within the tube increases, the tube tends to straighten. As the pressure decreases, the tube resumes its normal semicircular shape. By fixing the open end and allowing the sealed end to move freely, the “straightening” movement of the tube can be used to move a needle across a dial. A simple spring, gear, and lever arrangement serves to return the needle as the pressure is reduced and the tube resumes its shape.

ELECTRICAL OIL PRESSURE GAUGE.—

Some automotive vehicles are equipped with electrical oil pressure gauges. These gauges may be either the balancing coil type (fig. 6-78) or the thermostatic type. The thermostatic oil pressure gauge operates very similarly to the thermostatic fuel gauge.

In the balancing coil type system, a variable resistor is incorporated in the engine sending unit to become the diaphragm of the engine sending unit (fig. 6-78, view A). Increasing oil pressure causes the diaphragm of the sending unit to become displaced (fig. 6-78, view B). This increases the resistance, causing the right coil of the pressure gauge to become stronger than the left coil. As a result, the armature and pointer swing to the right, indicating an increase in oil pressure. The opposite takes place with a decrease in oil pressure.

An absence of oil pressure during engine operation indicates a faulty oil system or inoperative oil pressure indicating system, and the engine should be stopped

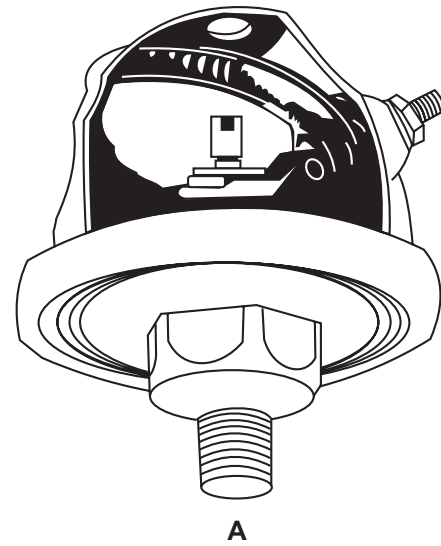

A

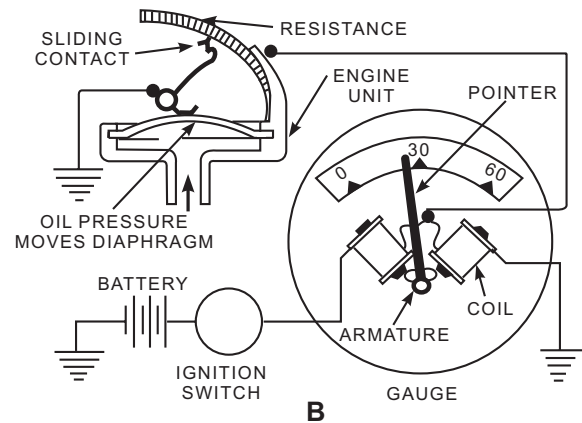

AS106078

Figure 6-78.—(A) Oil pressure sending unit; (B) Schematic diagram of balancing coil oil pressure indicating system.

immediately. The trouble must be located and repairs made before the engine is restarted.

Temperature Gauge

Temperature gauges, usually mounted on the instrument panel, are used to indicate the temperature of engine coolant, engine oil, transmission fluid, etc. Temperature gauges are operated electrically or by the Bourdon tube. The gauges discussed in the following paragraphs were designed to indicate the temperature of engine coolant.

BOURDON TUBE TEMPERATURE GAUGE.—

When the temperature gauge is a Bourdon tube (previously described), it is actuated by pressure conducted to it from a bulb that is screwed into the water jacket of the engine. The heat of the water affects the liquid in the bulb. The liquid vaporizes at a very low

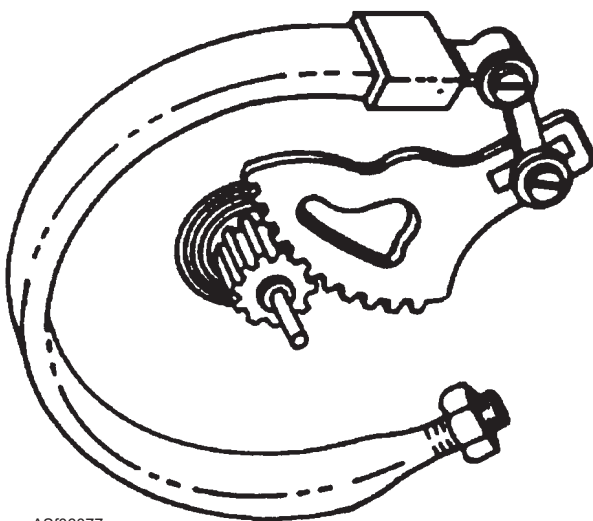

AS106077

Figure 6-77.—Bourdon tube.

temperature and the gas flows through the capillary, a very small tube connecting the bulb to the gauge. The greater the heat, the more vapor is given off and the greater the pressure; thus, higher temperature is indicated on the gauge.

ELECTRICAL TEMPERATURE GAUGE.—

The electrical temperature gauge (fig. 6-79) functions on much the same principle as the balancing coil fuel gauge and oil pressure gauge.

The temperature gauge consists of two coils at right angles to each other with an armature at the intersection of the coil axes. Connected to the armature is a pointer. The sending unit is a resistor whose resistance varies inversely with the temperature of the engine. When the engine temperature is high, the sender's resistance is low; when the temperature is low, the resistance is high. On the low-temperature side of the gauge unit, the coil is connected directly across the battery. Thus, there exists a constant magnetic strength in that coil, which attracts the armature and pointer to the low-temperature side. However, the coil on the high-temperature side is connected in series with the resistance of the sending unit and across the battery. Since the sender's resistance varies with temperature, the coil's magnetic strength varies. More current flows when the resistance is low (high engine temperature), and so a stronger magnetic field is created. As engine temperature increases, the greater magnetic strength of the high-temperature coil attracts the armature and pointer to a point of balance between the two sides. The scale is calibrated to the pointer movement.

Warning Lights

Some automotive manufacturers prefer a warning light system that indicates certain operating conditions,

rather than a gauge indicating system. The warning light is usually controlled by switches that may be operated by pressure, temperature, or mechanical linkage. You will encounter vehicles that use either a warning light system or a combination of warning light and gauge systems.

NOTE: To provide a means of testing the warning lights, they are usually wired so that they illuminate when the ignition switch is placed in the starting position.

TEMPERATURE LIGHT.—Most late model vehicles use an engine temperature warning light (located on the instrument panel) in place of the conventional engine temperature gauge. The warning light is wired in series with the ignition switch and the engine temperature sending unit. The sending unit provides ground for the warning lights when its contacts are closed. There are two systems for the temperature warning lights that are commonly used.

One of the systems contains a cold light (green) and a hot light (red). These lights are controlled by the engine temperature sending unit, which has two sets of contacts, one set being normally closed for the cold light and one set being normally open for the hot light. The contacts are mounted on bimetal strips, which cause them to open and close at predetermined temperatures. For example, when the engine is first started, the cold light comes on until the engine reaches normal operating temperature. Then, the cold light switch contacts open and the light goes off. This lets the operator know that it is safe to apply load to the engine, which is then at normal operating temperature. Likewise, if the engine overheats, the hot light switch contacts close and the hot light comes on, warning the operator of the overheating condition.

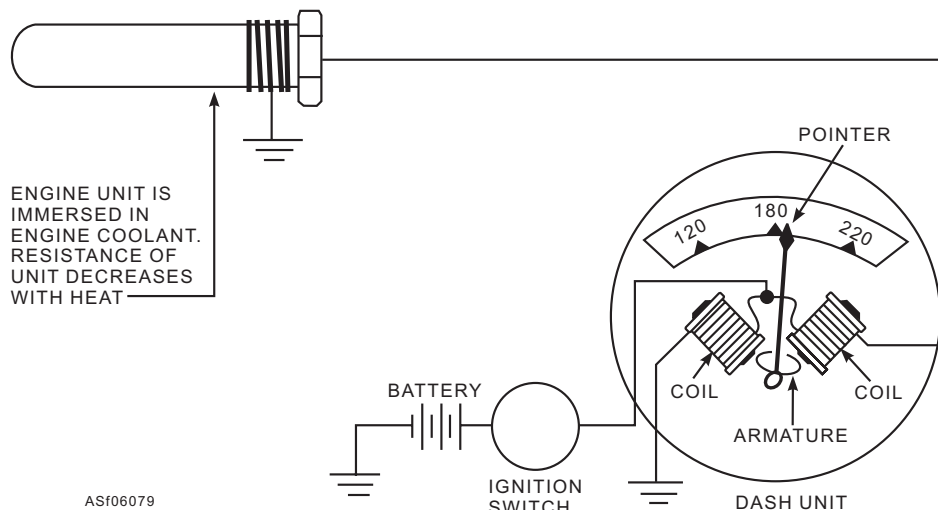

Figure 6-79.—Electrical temperature gauge.

The other system mentioned operates on the same principles but does not have a cold warning light. It has the hot warning light and an engine temperature sending unit with a single set of normally open contacts. If the engine overheats, the contacts close and turn on the hot warning light.

OIL PRESSURE LIGHT.—The oil pressure warning light installed on some vehicles is also located on the instrument panel to indicate when the oil pressure is very low. The warning light is wired in series with the ignition switch. The oil pressure switch is located on the automotive engine.

The oil pressure switch contains a diaphragm and a set of contacts. When the ignition is turned on, the warning light should illuminate, because the light circuit is energized through the closed contacts in the oil pressure switch. When the engine is started, built-up oil pressure compresses the diaphragm, opening the contacts, and thereby opening the circuit and causing the warning light to go out. The warning light is usually red and indicates a bright “Oil” on the instrument panel.

ALTERNATOR LIGHT.—Some vehicles use an alternator warning light mounted on the instrument panel in place of the ammeter. The light indicates to the operator when the alternator is not charging the battery. The warning element is a panel-mounted window (usually red) behind which is mounted a small light bulb. The light comes on when the ignition is turned on and the alternator is not charging. The circuit is completed from the ignition switch, through the light, to a terminal on the indicator light relay.

When the engine is running, the alternator speed is sufficient to provide a voltage higher than that of the battery. The operating coil of the indicator light relay will be energized, opening the circuit between the indicator light and the battery.

Hour Meter

Some support equipment requires servicing or maintenance after operating a certain amount of time. Hour meters (fig. 6-80) provide maintenance personnel a means of determining the specific amount of time the equipment has operated. With the information from the hour meters and maintenance instructions, maintenance personnel can determine what maintenance is required and when to perform it.

There are two types of hour meters commonly used on support equipment. These are the electrically driven (most common) and the mechanically driven types. The

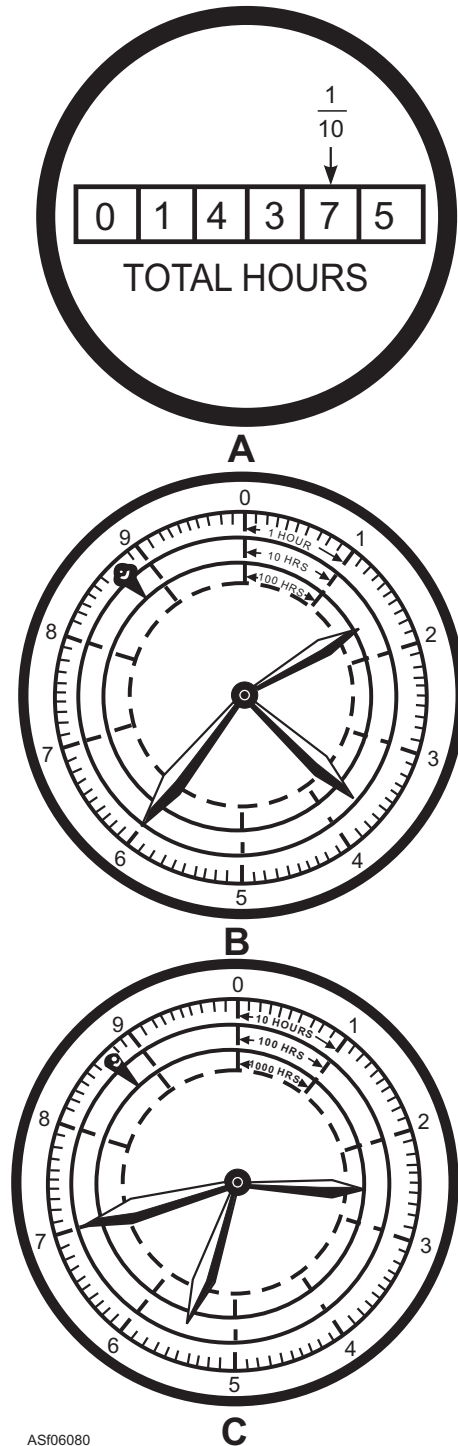

Figure 6-80.—Hour meters.

electrically driven type records elapsed time (clock hours). The mechanically driven type records time after a certain number of functions have taken place. For example, the hour meter may be designed to advance an hour after the crankshaft of an engine has completed as many revolutions as it normally would during an hour's operation.

Hour meters may have a counter dial, as shown in figure 6-80, view A, or a radial dial, as shown in views B and C. The use of different dial configurations on hour meters causes a great deal of confusion for many of the personnel who are responsible for reading the meters. (Compare the three dial configurations shown in figure 6-80.) The meters are easy to read, but each must be observed very closely and considered individually. The second number from the right on the meter in view A is in tenths; therefore, the meter indicates 143.75 hours. On many meters with this type of dial, the first number on the right is in tenths (indicated on the dial of the meter); and if this were the case, this particular meter would be indicating 1,437.5 hours.

The fractional numbers (tenths and hundredths) are usually a different color. When the primary numbers are black, the fractional numbers are red.

At a quick glance, the hour meters shown in views B and C look the same, but from a closer examination, you can see that identical hands traveling the same distance indicate different amounts of time. For example, on the meter shown in view B, when the large hand (outer scale) has traveled from “zero to one,” 1 hour has passed, but on the meter in view C, 10 hours would have passed. Therefore, determine how each dial is calibrated before taking a reading. Always read the scales in descending order. For example, on the meters shown in views B and C, read the inner scale first, middle scale second, and the outer scale last. On the meter shown in view B, the inner scale indicates 100 hours, the middle scale 30 hours, the outer scale 6 hours, and, putting them all together, the meter indicates 136 hours. The meter in view C indicates 2,570 hours.

The purpose of the small hand located below the 9 on the meters shown in views B and C is to indicate whether or not the meter is operating. Movement of the large hands cannot be detected by looking at the meter, but movement of the small hand can be detected easily with the eye.

Start Counter Meter

The start counter (fig. 6-81) is an electrically operated additive meter, which is normally used to record the total number of complete starts of an engine since initial or overhaul installation. The start counter is only used on a few items of support equipment; however, it does provide valuable information on such

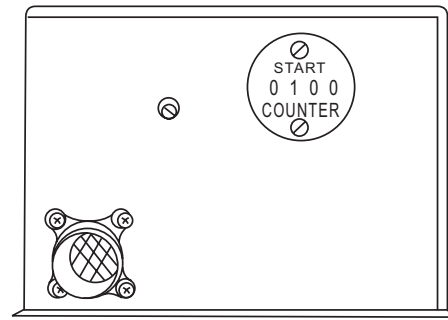

AST06081

Figure 6-81.—Start counter meter.

items of equipment as gas turbine compressors on which the number of starts is of vital importance.

The start counter in figure 6-81 is shown mounted in the electrical control box of a GTC 85-73. It is also used on other items of support equipment. This start counter is provided with a plate incorporating four windows with dials showing through. The first dial on the right records starts in increments of even numbers, zero through eight, and any odd number between is indicated when the numbers stop at any intermediate point between any two even numbers. The second dial from the right records starts in tens, the third dial from the right records starts in hundreds, and the fourth dial from the right records starts in thousands. The dials that record starts in tens, hundreds, and thousands show both odd and even numbers.

Speedometer and Tachometer

A speedometer (fig. 6-82, view A) is used to indicate vehicle speed in miles per hour. An odometer

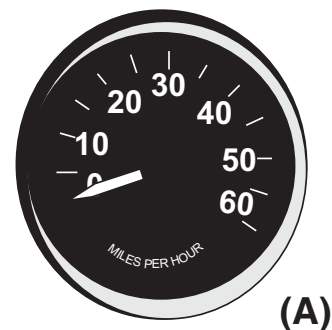

(A)

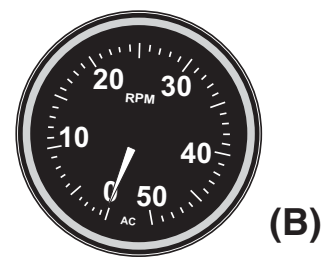

(B)

AST06082

Figure 6-82.—(A) Speedometer; (B) Tachometer.

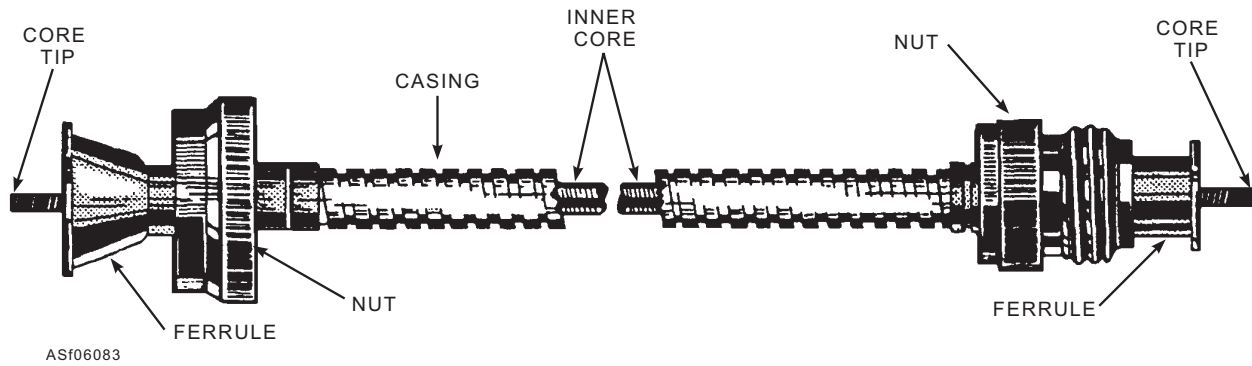

Figure 6-83.—Speedometer and tachometer drive shaft.

(frequently on the same instrument) records distance traveled. The speedometer may be driven either by a flexible shaft or by electrical input. The type that uses a flexible shaft has a set of gears in the vehicle transmission. This set of gears drives the flexible shaft, and the flexible shaft, in turn, drives the rotating part of the speedometer and the gears of the odometer. The gears are designed for the particular vehicle model and take into consideration the tire size and rear axle ratio. The flexible shaft consists of an outer casing and an inner drive core (fig. 6-83). The speedometer driven by electrical means is comprised of two separate units, a generator (or transmitter) and an indicator, connected by electrical wires.

The tachometer (fig. 6-82, view B) is ordinarily used to indicate vehicle engine speed. It is similar to the speedometer, except that the face dial indicates revolutions per minute instead of miles per hour. The

tachometer may be driven either by a flexible shaft or by electrical means. The type that uses a flexible shaft is driven, through the shaft, from the vehicle generator, camshaft, or distributor shaft. The tachometer driven by electrical means is comprised of two separate units, a generator (or transmitter) and an indicator, connected by electrical wires. Many tachometers are self-contained units operated by voltages from the negative side of the ignition coil. An hour meter is often incorporated in the tachometer to record operating time.

Even though the internal parts of the various instruments differ in construction and appearance, they all incorporate the same basic components and operate on the same principles.

SPEED INDICATOR.—The speed-indicating portion of a speedometer (fig. 6-84) or tachometer of

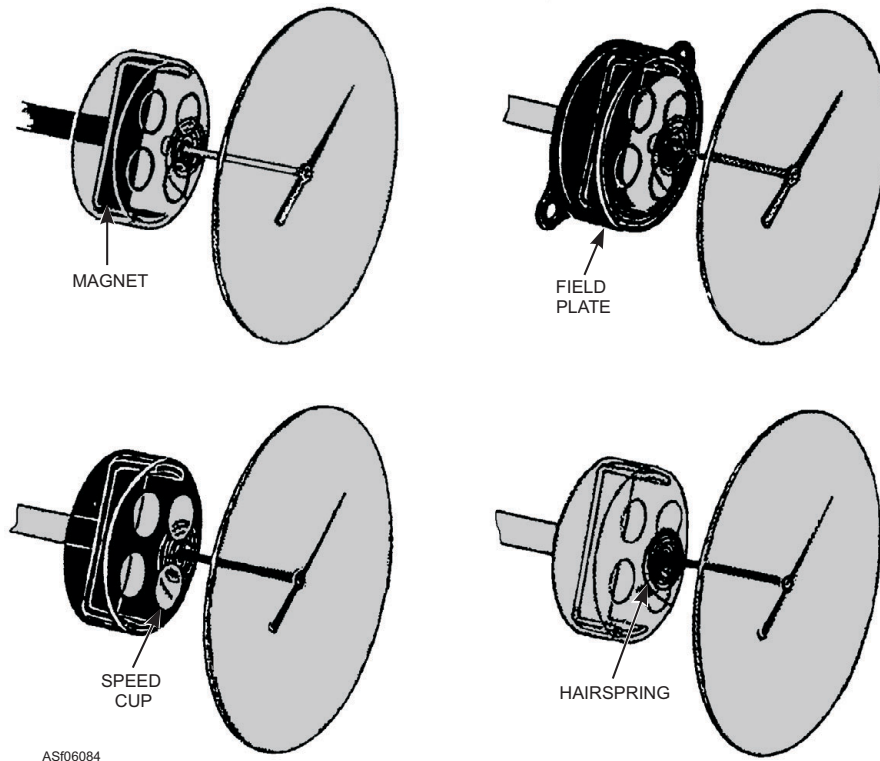

Figure 6-84.—Sectional view of indicating portion of the speedometer.

the magnetic type is operated by a permanent magnet, which is driven by a flexible shaft. Around this revolving permanent magnet is a stationary field plate. (Some instruments have a revolving field plate.) A movable speed cup is located between the magnet and field plate, with the indicating pointer attached to the end of the speed cup staff.

As the magnet revolves within the speed cup, it sets up a rotating magnetic field, which exerts a pull, or magnetic drag, on the speed cup, making it revolve in the same direction. Movement of the speed cup is retarded and held steady by a hairspring attached to the speed cup staff. The speed cup comes to rest at a point where the magnetic drag is balanced by the retarding force created by the hairspring. An additional function of the hairspring is to pull the pointer back to zero when the vehicle or engine stops.

There is no mechanical connection between the revolving magnet and the speed cup. As the speed of the magnet increases due to vehicle acceleration or (as in the case of a tachometer) to an increase in engine speed, the magnetic drag on the speed cup also increases and pulls the speed cup farther around, thus registering a faster speed by the pointer and face dial. The magnet's

magnetic field is constant, and the amount of speed cup deflection is at all times proportional to the speed at which the magnet is being revolved.

TOTAL ODOMETER.—The total odometer (fig. 6-85, view A) is driven through a series of gears originating at a spiral gear out on the magnet shaft. This gear, known as the first gear, drives an intermediate second gear and a third gear, which is connected to a fourth gear at the odometer. The fourth gear turns the odometer through a series of star pinion gears inside the odometer dials, or wheels. The total odometer usually has five figure wheels, or dials, and is so constructed and geared that as any one wheel finishes a complete revolution, it turns the next figure wheel to the left one-tenth of a revolution. Most models record to 99,999 miles, and then automatically zero themselves.

TRIP ODOMETER.—The trip odometer (fig. 6-85, view B) is also driven by the third gear, through the trip odometer drive gear and another gear at the trip odometer. The trip odometer usually has four wheels, and is so constructed that as any one finishes a complete revolution, it turns the next wheel to the left one-tenth of a revolution. The wheel on the extreme right registers in tenths of a mile. Most models record to 999.9 miles,

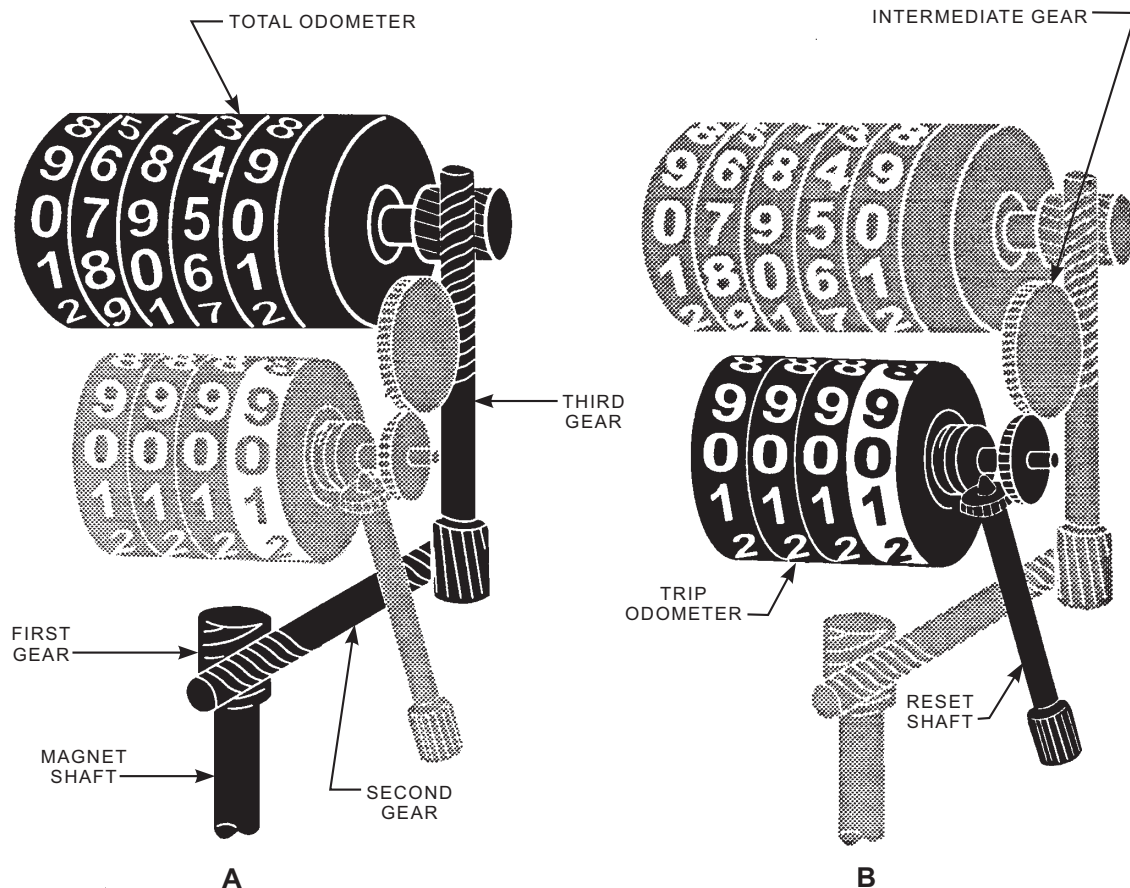

ASf06085

Figure 6-85.—(A) Total odometer; (B) Trip odometer.

then automatically zero themselves. Also, they are usually equipped with a reset mechanism so that the mileage on the trip odometer can be reset as desired.

ELECTRICAL SPEEDOMETERS AND TACHOMETERS.—Electrical speedometers and tachometers use a small generator (transmitter) that is mechanically driven. The voltage produced causes a synchronous motor (receiver) in the indicator assembly to operate, thereby indicating vehicle and engine speed.

There may be several different arrangements or combinations of the electrical speedometer and tachometer. For instance, the speedometer and tachometer may be two completely independent systems, or there may be one transmitter and one receiver with a dual face, as shown in figure 6-86. If this instrument is used on a vehicle and driven by gears in the transmission, the tachometer will be inaccurate until a certain gear, normally high gear, is reached. Another arrangement involves two transmitters—one driven by the transmission for vehicle speed, and one driven by the engine for engine rpm. This type of arrangement uses one indicator containing two receivers with independent pointers and dials. With this arrangement, both the speedometer and the tachometer are accurate in any gear.

The speedometer transmitter is driven from the final drive of the vehicle, usually the output shaft of the

transmission. The tachometer transmitter is usually driven from an engine accessory drive, such as the ignition distributor drive. The output voltage of a transmitter is proportional to the speed at which it is driven; likewise, the speed of a receiver is proportional to the output voltage of the transmitter. The receiver speed determines the position of the pointer on the face of the indicator.

HORNS

The horn installed on support equipment is used as a warning device to pedestrians or crew members of a moving vehicle. The horn is a magnetic switch (somewhat like a vibrating voltage regulator relay), which sets a diaphragm into rapid vibration when connected to the battery. Horns may be used in matched pairs so that a blended and more resonant signal is produced.

Operation

The most common type of horn (fig. 6-87) is the vibrator type. A winding is connected in series with a set of contacts within the horn. The contacts are closed when the horn is not energized.

When the external circuit to the battery is closed (by the horn push button or horn relay), current flows through the contacts and winding. This causes the

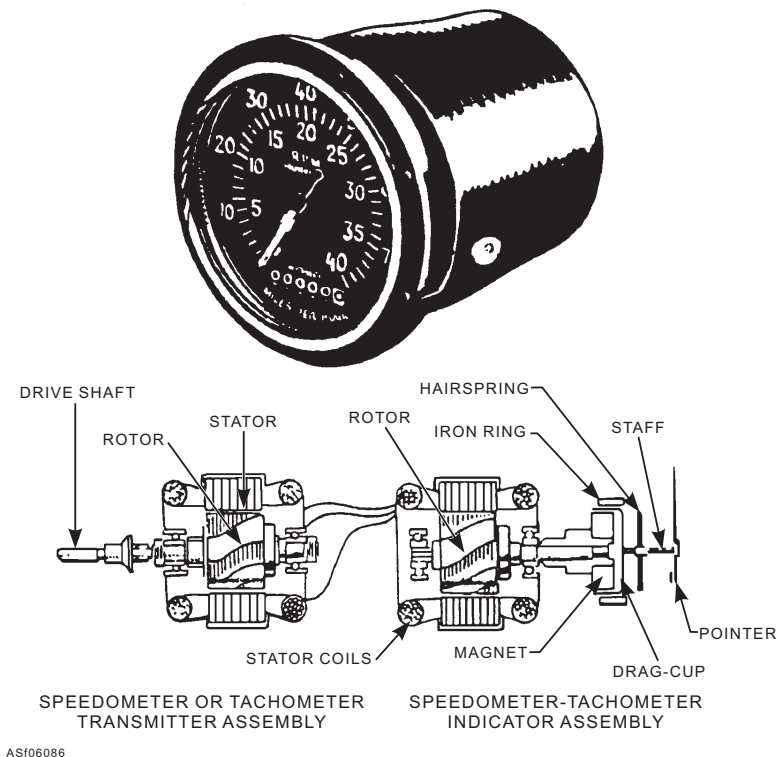

Figure 6-86.—Electrical speedometer-tachometer.

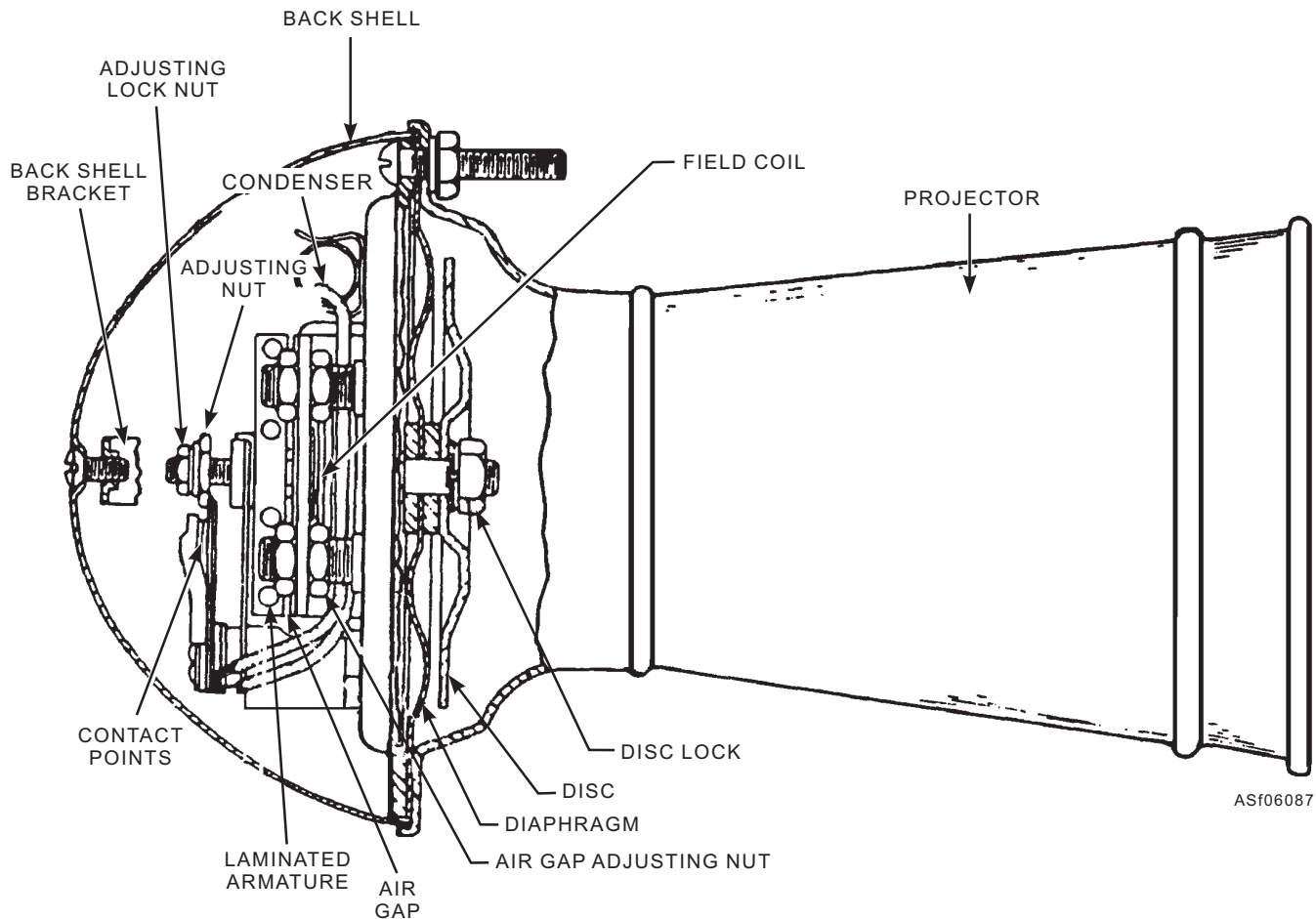

Figure 6-87.—Electrical vibrator-type horn.

magnetic field to attract the armature of the coil to the winding core. The armature is mounted to the horn diaphragm so that movement of the armature causes a distortion of the diaphragm. The armature movement also operates the horn contact points that break the circuit.

When the contact points open, the magnetic field of the winding collapses, and the armature returns to its normal position as the distortion of the diaphragm is relieved.

When the contacts are closed again, a new surge of current induces magnetism in the coil and starts a second movement of the diaphragm. This cycle is repeated rapidly. Vibrations of the diaphragm within an air column produce the note of the horn.

Adjustment

Before making any adjustment, ensure that the horn is properly grounded and there is correct voltage at the horn. To obtain a good sound from a horn, a minimum

of 11 volts is required for the 12-volt horn, and a minimum of 22 volts is required for the 24-volt horn.

Tone and volume adjustments are made by loosening the adjusting locknut and turning the adjusting nut. This very sensitive adjustment controls the current consumed by the horn. Increasing the current increases the volume; however, too much current will make the horn sputter, and may lock the diaphragm.

Dual Horns

In dual horns, one horn having a low pitch is blended with another horn having a high pitch. These horns, although operated electrically, produce a sound closely resembling that of an air horn. The sound frequency of the low-pitch horn is controlled by a long air column, and that of the high-pitch horn by a short air column. The air column is formed by the projector and by a spiral passage cast into the base of the horn.

Most horns draw enough current to necessitate having a relay in the circuit. A horn circuit that has a

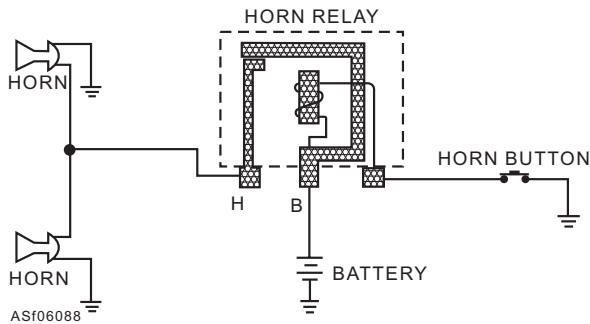

Figure 6-88.—Dual horns and relay circuit.

relay is shown in figure 6-88. By having a relay in the horn circuit, the contacts of the horn button (switch) are protected, and many more hours of trouble-free service are obtained than with a horn circuit that does not have a relay.

DIRECTIONAL (TURN) SIGNALS

The directional signals (fig. 6-89) permit the operator to signal his intention to make a right or left turn. The direction of turn is indicated by flashing lights on the front and rear, and sometimes on the side of the vehicle. The rear lights are red in color and part of the stoplight system. The front directional signals are usually white or amber in color. Both the front and rear lamps (bulbs) of the directional signal system normally

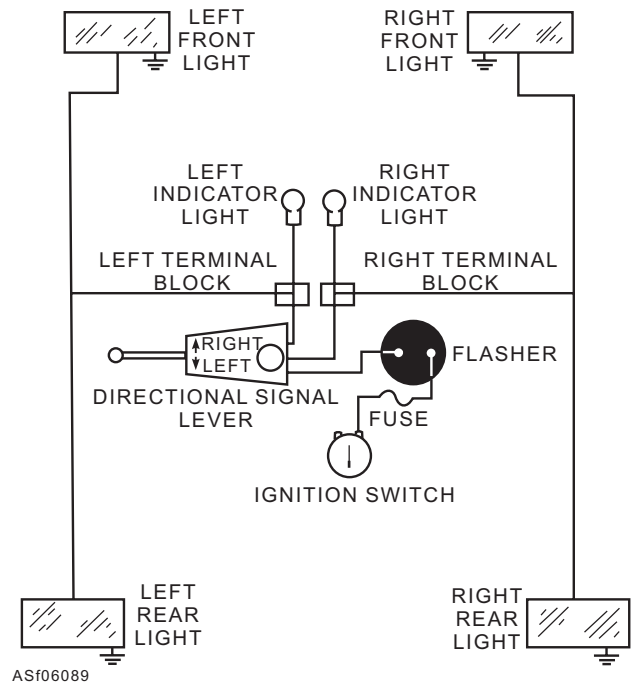

Figure 6-89.—Pictorial diagram of a directional signal system.

contain a second filament, which is used in the parking light system. Indicator lights are installed on the instrument panel of the vehicle to provide the operator with the following indications:

- The direction of the turn.

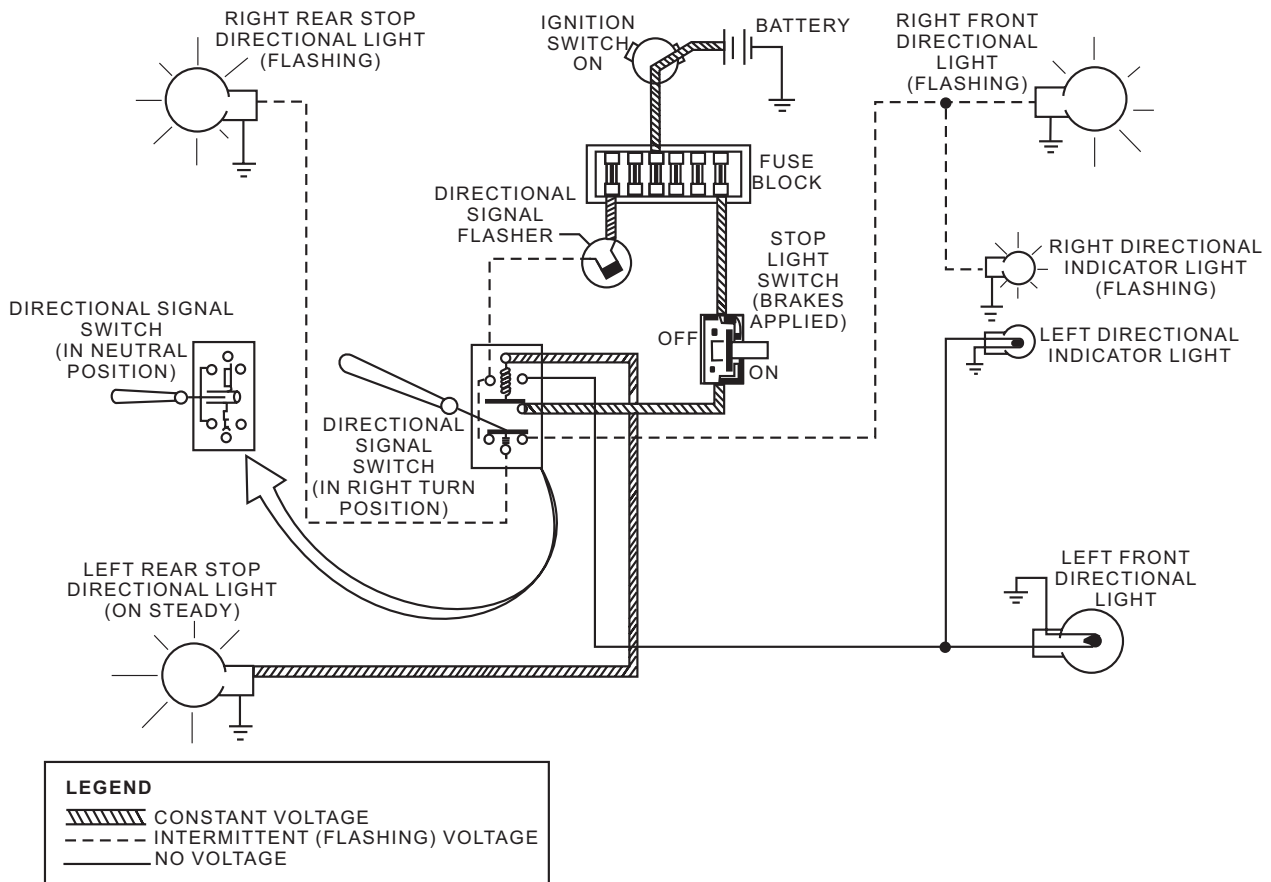
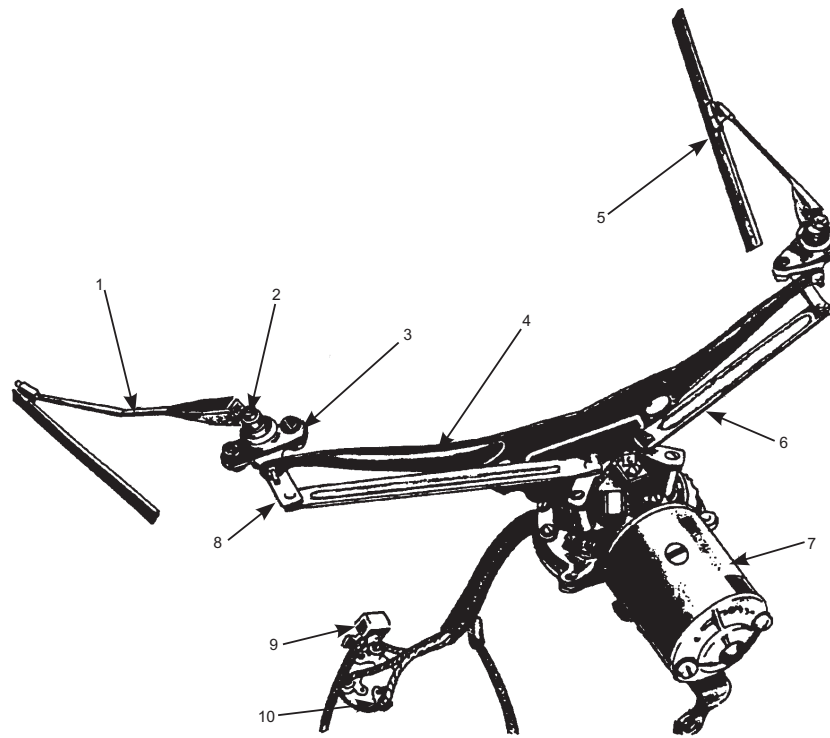

Figure 6-90.—A representative stop-directional light system.



- | | | | | |
|------------------|---------------------|----------------|----------|--------------------|
| 1. Wiper arm | 3. Pivot cover | 5. Wiper blade | 7. Motor | 9. Circuit breaker |
| 2. Wiper arm nut | 4. Mounting bracket | 6. Linkage | 8. Pivot | 10. Wiper switch |

Figure 6-91.—Electrically operated windshield wipers.

- Whether or not the directional signal switch lever has returned to the neutral position after completion of a turn.
- Whether the system is operating properly or improperly.

When the signal switch lever is moved in one direction or the other, a circuit is completed between the battery and the proper indicating lights. The connections are completed through a flasher, a device that opens and closes the circuit at proper intervals, providing a flashing signal. The flashing action is a result of heating a thermostatic element within the flasher. The wiring circuit of a representative stop-directional light signal system indicating a right turn with the brakes applied is shown in figure 6-90.

WINDSHIELD WIPERS

Windshield wipers usually consist of a metal strip with a rubber insert attached to a rod that swings in an arc across the windshield. The necessary mechanical linkage is driven by an electric motor. Windshield wipers are not a common support equipment accessory. However, they must be installed when the operator is situated in an enclosure. Examples are the crash cranes, some types of fire trucks, and enclosure-equipped tow tractors.

Electrical windshield wipers (fig. 6-91) are usually driven by shunt or compound wound motors. The wipers may be driven in three different speeds—slow, medium, and fast.

To obtain satisfactory operation from electrical windshield wipers, it is essential that the motor, linkage, and drive pivots operate freely. Otherwise operation may be noisy or complete failure may result.

A modern three-speed windshield wiper schematic is shown in figure 6-92. The system contains a compound-type motor, a gearbox, and a relay.

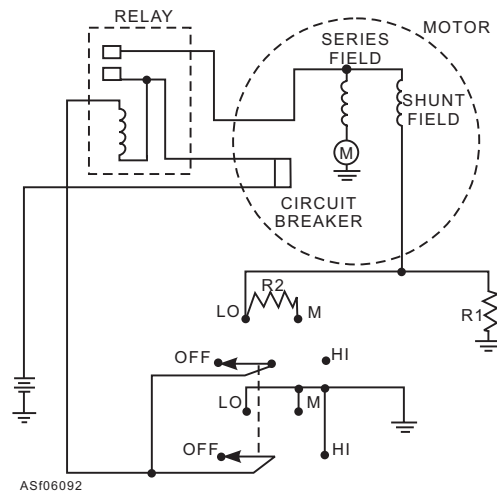

Figure 6-92.—Schematic diagram of a three-speed windshield wiper.

The control switch has four positions—OFF, LO, MED, and HI. Wiper speed is controlled by increasing or decreasing the amount of current in the shunt field. At low speed, the motor has no external shunt field resistance, and maximum shunt field current flows. For medium speed, resistors R1 and R2 are connected in parallel with each other and in series with the shunt winding, thereby reducing the shunt field current. In high speed, only R1 is in series with the shunt field, resulting in maximum shunt field resistance, minimum shunt field current, and the least opposition to the series field. When the switch is placed in the “OFF” position, the motor continues to operate until a cam on the crank arm strikes a switch button (not shown), opening the circuit and placing the wiper in the park position.

Some windshield wiper systems have a windshield washing unit. The washers are energized by depressing a button, which is part of the control switch. When the button is depressed, the washer relay coil is energized, placing the pump in operation.

NOTE: Electrical windshield wipers, heater fans, defroster fans, and other accessories are driven by small electrical motors. The amount of current drawn will depend on the particular motor and the load placed on it. The motors, with the exception of the starting motor, should be connected to the ammeter so that any battery current used to run them is indicated by the ammeter. The construction and theory of operation of ac and dc motors are covered in detail in NEETS, Module 5.

HEATERS AND DEFROSTERS

Hot water heaters are part of the engine cooling system, since they circulate the cooling liquid from the engine through the heater radiator. The heater has an electrically driven fan, which circulates air through the heater radiator so that the output air is warmed.

The defroster operates in a manner similar to the heater, usually deriving heat from the same heater radiator. The defroster, however, directs the flow of warm air against the windshield to prevent condensation or freezing of moisture.

The only service the heater will normally require is a periodic flushing out when the engine radiator is flushed. A defective heater fan motor is usually replaced with a new one. However, it is possible to replace bearings, armature, brushes, and certain other small parts under emergency conditions.

AUXILIARY POWER RECEPTACLES

Auxiliary power receptacles vary from vehicle to vehicle. In some applications, the auxiliary power receptacle is mounted near the equipment battery. The receptacle has two large pins; one pin is connected to the positive terminal of the battery, and the other pin is connected to the negative terminal.

The auxiliary power receptacle is used to obtain power from an external source for charging batteries, engine starting, and for operating other components on the vehicle.

The NC-8 and a few other power units provide convenience outlets (power receptacles) of ac and dc for use by the maintenance crews in performing their duties. In this application, the power generating system of the vehicle provides power to the outlets. Through proper placement of switches, power can be obtained for test equipment, soldering irons, etc., so tests and repairs can be made without having to move to shop or hangar spaces.

LIGHTING SYSTEM

The lighting system consists of all the lights, control devices, protection devices, and wiring harnesses necessary for a piece of equipment to do its assigned job. The following paragraphs describe the components of the lighting system and suggested maintenance procedures.

Headlights

A cutaway view of a sealed beam headlight is shown in figure 6-93. In this type of light, the filament, reflector, and lens form a single unit. The unit is completely sealed so the reflector does not become tarnished and the light output is not seriously affected by age. The filament is correctly focused in relation to the lens and reflector by the manufacturer, and the alignment (aiming) is the only adjustment that can be made. Connection into the circuit is made by blade-type connectors and a bayonet plug.

Two filaments are provided in the sealed beam unit. One provides an upper or high beam; the other provides a depressed or low beam. When either filament burns out, corrective action requires that the whole unit be replaced. However, the sealed beam unit has a greater filament life expectancy than other types of bulbs and requires no maintenance during its lifetime.

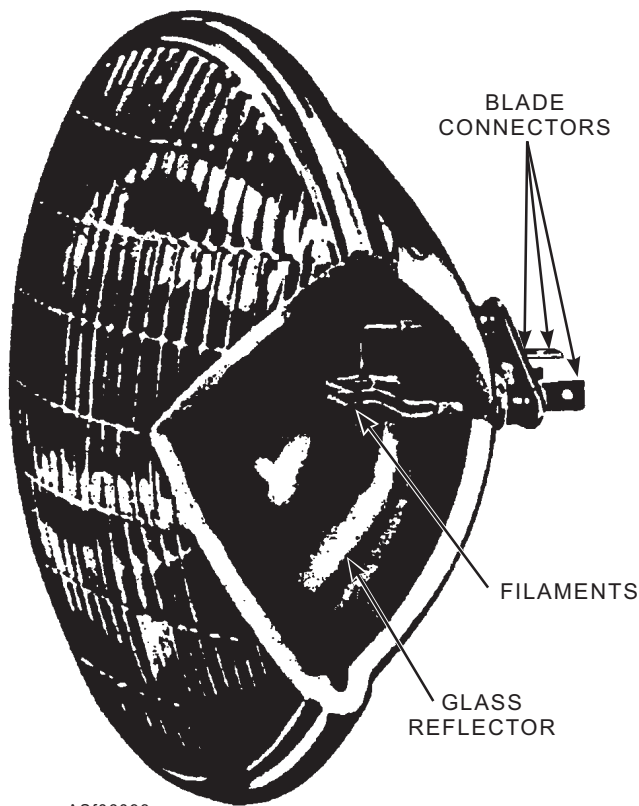

ASf06093

Figure 6-93.—Cutaway view of a sealed beam headlight.

On some units of support equipment, the headlights have only one filament; instead of blade connectors for a bayonet plug, they have screws for connection of the leads.

Four headlights (two on each side) are used on some modern equipment. The inboard units have the numeral 1 embossed on the lens; the outboard units have the numeral 2 embossed on the lens. The No. 1 unit has only one filament and a two-blade connector. The No. 2 unit has two filaments (as in the single unit described above) and a three-blade connector. When a high beam is selected, the inboard unit provides a high intensity, far-reaching beam, while the off-focus of the outboard units illuminates the area directly in front of the vehicle. When the lights are switched to low beam (dimmed), the inboard units turn off and use only the low-beam filaments of the outboard units.

To align the headlights, various types of special alignment equipment may be used. Always follow the equipment manufacturer's instructions for their use. Some models will provide details on aiming headlights manually.

When it becomes necessary to replace a sealed beam unit, remove only the screws or springs holding the unit's retainer ring. Do not move the alignment screws (fig. 6-94).

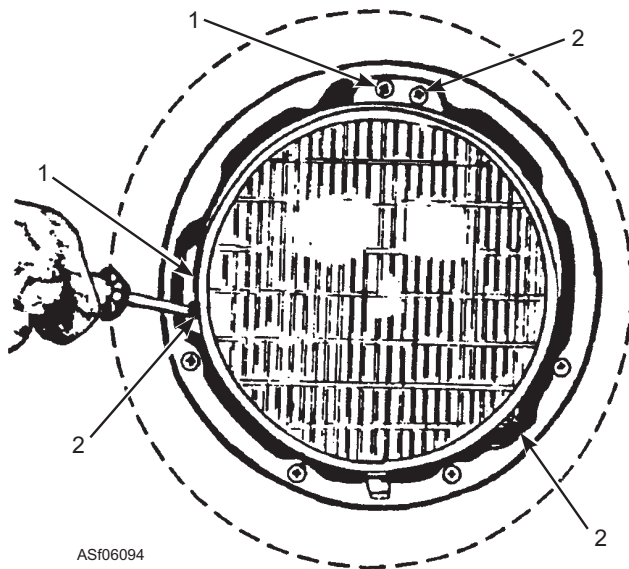

ASf06094

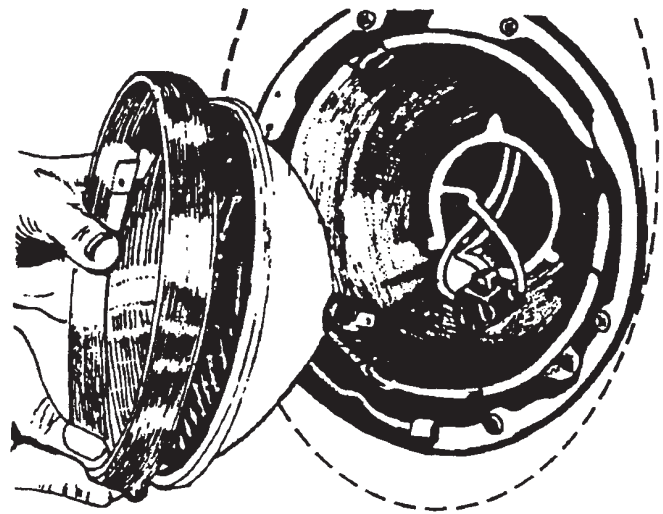

- 1. ALIGNING SCREWS
- 2. RETAINING SCREWS

Figure 6-94.—Sealed beam headlight installation.

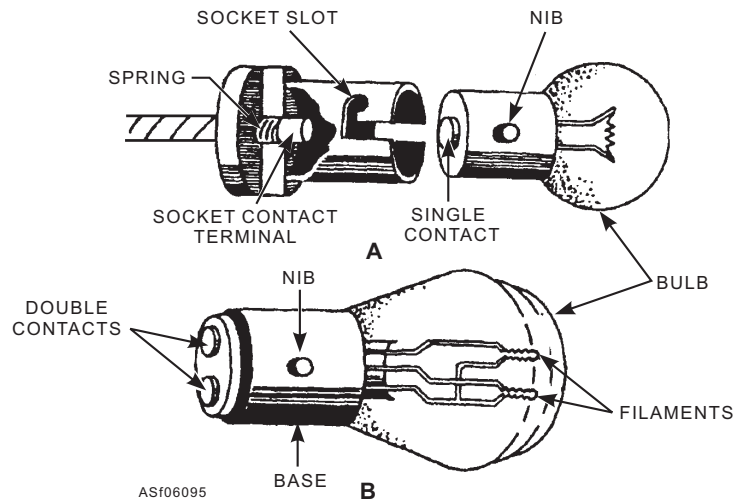

Figure 6-95.—Commonly used light bulbs.

The bulbs (lamps) used in these lights are generally single contact, single filament; also used are double-contact, double-filament bulbs (fig. 6-95). Both types are provided with nibs to lock into bayonet sockets. Always replace a light bulb with one of the same type. If there is any doubt as to the type to be used, refer to the applicable maintenance manual to obtain the correct type.

Instrument Lights

Ordinarily, indirect lighting is used for the instrument lights, which are on whenever the light

switch is in any of the ON positions. Many vehicles are equipped with an instrument panel light switch so that the instrument panel lights can be dimmed or turned off when desired.

Parking Lights

The smaller lights used for parking are sometimes located immediately above or below the main headlights. Side lights sometimes serve as parking lights. The parking light switch is incorporated into the main light switch.

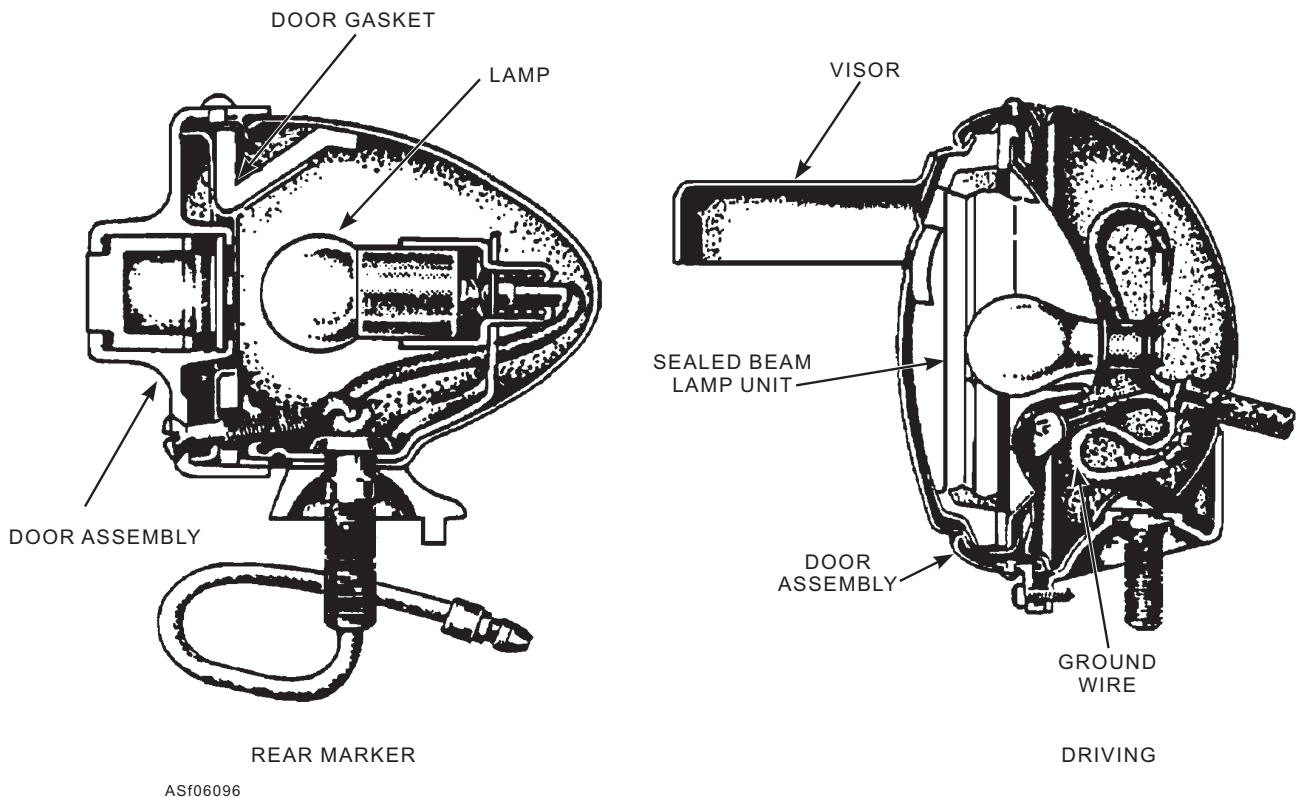

Figure 6-96.—Rear marker and blackout driving lights.

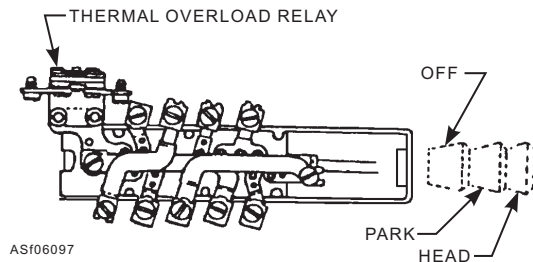

Figure 6-97.—Main light switch.

Taillights and Stoplights

Taillights and stoplights are ordinarily combined, with two light bulbs contained in a single housing with a red lens. A larger light bulb (about 15 candlepower) is used for the stoplight; a smaller light bulb (about 3 candlepower) is used for the taillight. Taillights and stoplights are sometimes enclosed in a single light bulb that has a double filament. Taillights are on whenever the light switch is in any of the ON positions.

Backup Lights

When a backup light is used, it is mounted so as to direct light to the rear of the vehicle. It is arranged and wired so that a switch turns it on when the gearshift lever is put into reverse position.

Blackout Lights

Blackout lights are used to enable a vehicle to move at night without being observed from the air. These

lights provide sufficient illumination to enable units in a convoy to keep in line while progressing at slow speeds. Two blackout headlights, two blackout taillights, and a blackout stoplight are provided for this illumination. All other lights in the vehicle are off when the blackout lights are on. Blackout driving and rear marker lights are illustrated in figure 6-96.

SWITCHES

In most vehicle installations, the lighting circuits are arranged so that the headlights, parking lights, taillights, and instrument lights are controlled by one switch (main light switch). The switch is a push-pull type or a push-pull with a rotary contact. The rotary contact is a rheostat used to control the intensity of the instrument lights. It is actuated by rotating the switch knob. These switches have three positions—OFF, PARK LIGHTS, and HEADLIGHTS. The light switch is located on the instrument/control panel within easy reach of the operator (fig. 6-97). Most types of current support equipment used aboard ship and on flight lines use a single toggle switch to operate lights.

Vehicles provided with blackout lights have a special blackout light switch, which incorporates the service lights and blackout lights in one unit. This switch is shown in figure 6-98, with its connections to the various units in the lighting system. The plunger knob has three positions—OFF, BLACKOUT LIGHTS, and SERVICE LIGHTS. In its second or middle position, the switch turns the blackout lights on

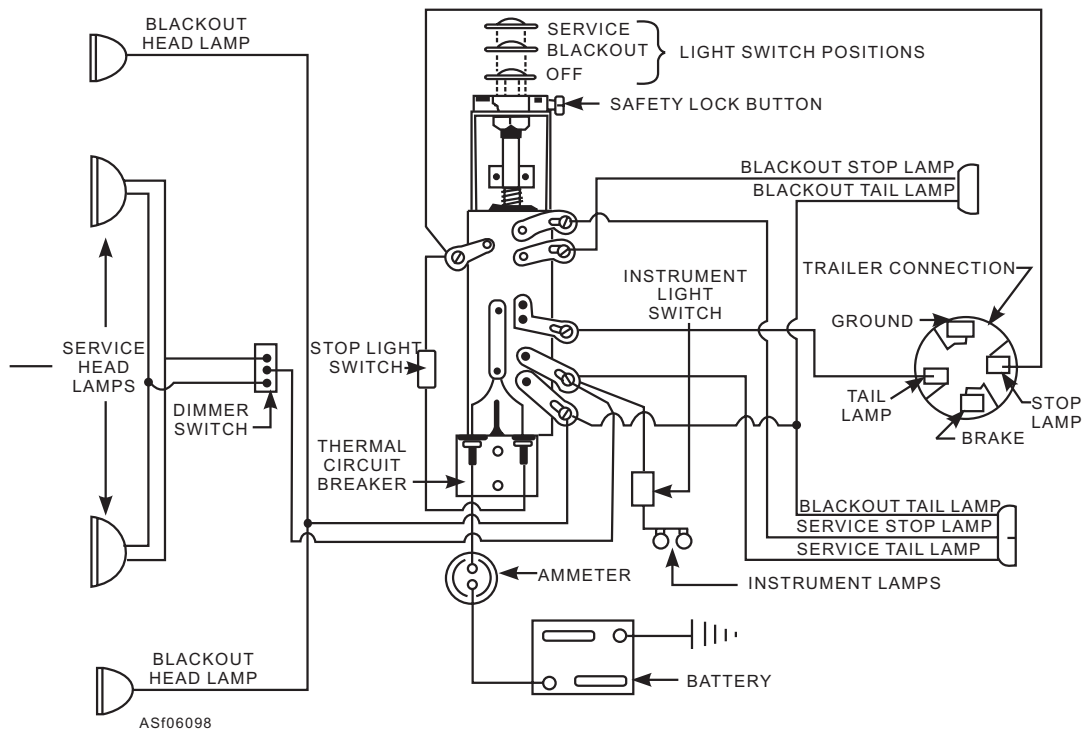

Figure 6-98.—Blackout light switch and connection.

and keeps all other lights off. The plunger knob cannot be pulled out to its third position until the safety lock button is pushed in. This safety feature prevents any lights visible from above being accidentally turned on during a blackout. In the third position, with the plunger knob pulled all the way out, the service lights are on and operate normally. A trailer connection is provided to operate taillights on the rear of the trailer. These are on when the switch is in either the second or third position.

Vehicles that are equipped with dual filament headlights have a switch that allows the operator to select high or low beams (dimmer switch). It is a foot-operated push button located on the floorboard. In newer vehicles, the dimmer switch may be combined with the directional switch on the steering column.

The stoplights are controlled by a switch that is actuated whenever the vehicle's service brakes are applied. It may be located on the master cylinder mount brackets. It is actuated by mechanical linkage; in the hydraulic system, it is actuated by hydraulic pressure.

RELAYS

Because of the limited voltage available to automotive lighting circuits, resistance of the wiring must be kept to a minimum to provide lighting of sufficient intensity. Some systems do this by using heavy gauge wire; others use relays.

To reduce voltage loss in the wiring, the relays are placed in such a position that only short lengths of heavy gauge wire is necessary to connect them. Since the main light switch and dimmer switch carry only low control current, voltage loss due to burned switch contacts is eliminated. Figure 6-99 shows a wiring diagram for a system using two relays—one for high beam and one for low beam. In some systems, these two relays are incorporated into one unit.

Another type of relay used in some automotive lighting systems is the current limiting relay. These are sometimes referred to as overload relays or circuit breakers. They can be found in two types. The thermal overload relay is incorporated as part of the main light switch; the solenoid relay is mounted separately on the vehicle fire wall.

FUSES AND CIRCUIT BREAKERS

Fuse boxes contain fuses and/or circuit breakers that protect the electrical circuits. When an overload condition exists, the fuse element melts or the circuit breaker opens to relieve the overload condition. When this happens, do not automatically replace the fuse or reset the circuit breaker. It is important to first correct the condition that caused the overload. Otherwise, the situation will repeat itself; or worse, the circuit will be damaged. When replacing a fuse or circuit breaker, be sure that the rating of the replacement component is no larger than that specified in the technical manual for that circuit.

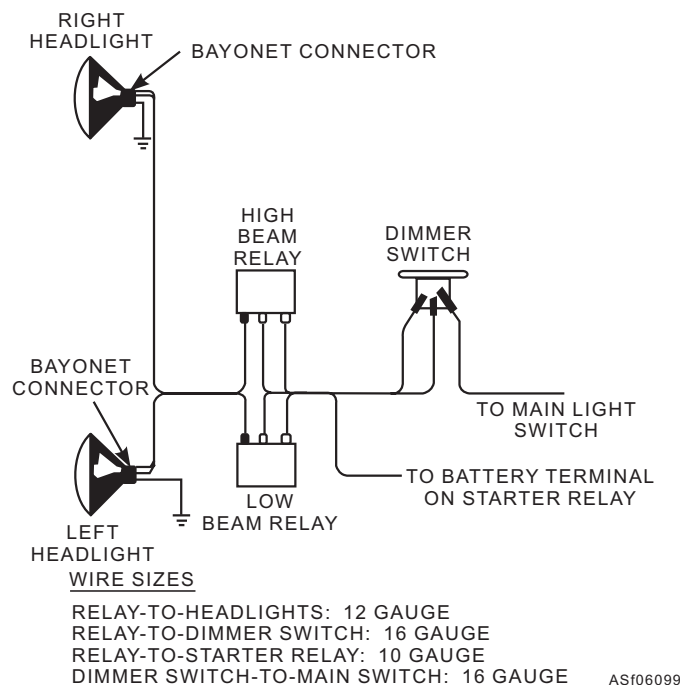

Figure 6-99.—Light relay wiring diagram.

- Q6-36. Which of the following items would be considered an accessory on support equipment?
1. AM/FM radio
 2. Electric windows
 3. Gauges
 4. Power seats
- Q6-37. Most fuel gauges are composed of two units and operated by what method?
1. Mechanically
 2. Automatically
 3. Manually
 4. Electrically
- Q6-38. Which of the following types of oil pressure gauges are most commonly used in SE?
1. Thermostatic and bourdon tube
 2. Bourdon tube and electrical
 3. Thermostatic and mechanical coil
 4. Electrical and mechanical coil
- Q6-39. Warning lights are usually controlled by which of the following devices?
1. Relays
 2. Switches
 3. Circuit Breakers
 4. Generators
- Q6-40. The oil pressure warning light is wired in what manner, if any, to the ignition switch?
1. In parallel
 2. In series-parallel
 3. In series
 4. It is not wired to the ignition switch
- Q6-41. Which of the following items of support equipment uses the start counter?
1. GTC-85
 2. MMG-1A
 3. NC-10C
 4. A/M32C-17
- Q6-42. What is the most common type of horn used in SE?
1. An air powered horn
 2. A diaphragm controlled horn
 3. A magnetic impulse horn
 4. A vibrator-type horn
- Q6-43. Which of the following components are used to prevent an item of SE from being seen from the air at night?
1. A low gloss paint scheme
 2. Blackout lights
 3. Low intensity headlights
 4. A light absorbing epoxy paint
- Q6-44. Which of the following locations would you normally find the stoplight switch?
1. Below the brake pedal
 2. Above the brake pedal
 3. On the master cylinder mounting bracket
 4. On the wheel cylinder mounting bracket

CHAPTER 7

POWER GENERATING SYSTEMS

INTRODUCTION

Power generating equipment is the mainstay of aircraft maintenance. In general, mobile power-generating systems are used for starting aircraft and for supplying power during maintenance procedures.

The systems described in this course are the NC-2A, NC-8A, NC-10C, and MMG-1A. These systems often differ greatly.

- The NC-2A has two generators—one ac and one dc.
- The NC-8A has one dual-purpose generator that produces ac and dc.
- The NC-10C and MMG-1A have one generator that produces ac only.

In the case of the MMG-1A, the dc output is derived from the ac input power that drives the motor generator. The input power is stepped down by a transformer and rectified for dc output. The NC-10C also uses ac power from its generator, and uses transformers and a rectifier type power supply to produce dc power.

Some basic electrical theory is presented in this course; however, to be prepared for advancement, you should review the Navy Electricity and Electronics Training Series (NEETS) modules for more detailed coverage of the topics covered here.

WARNING

Electrical equipment designed for aircraft servicing can provide sufficient voltage to be dangerous to human life.

SOLID-STATE ELECTRONICS

LEARNING OBJECTIVE: Identify the operating characteristics of solid-state components used in power-generating equipment.

Electronic devices, controls, and outputs are covered here. For in-depth details, refer to NEETS, Module 7.

SEMICONDUCTORS

A semiconductor is a device that ordinarily acts as an insulator, but under certain specific electrical conditions, it will become conductive. Figure 7-1 shows the resistance values of basic material in the three general groups used in electronics (conductors, semiconductors, and insulators).

Semiconductor Materials

Silicon and germanium are the most common types of materials used to make semiconductors. The greater availability of silicon gives it an advantage over germanium. Silicon is also electrically superior in some respects.

N-TYPE MATERIAL.—Generally, silicon and germanium do not conduct electricity. But by a process called *doping* (which is to add selected impurities), the electrical properties of silicon and germanium are altered. Silicon is doped with phosphorus—germanium with arsenic or antimony. When a semiconductor is doped in this way, it is called *N material*. Doping N material is the insertion of additional negative charges.

P-TYPE MATERIAL.—When silicon or germanium is doped with boron, conductivity increases. Semiconductor material doped in this way is called *P material*. It is the insertion of positive charges.

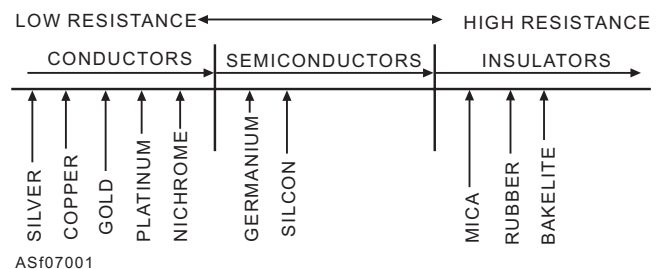

Figure 7-1.—Resistance chart of common conductors, semiconductors, and insulators.

CARRIERS.—Electrons in N materials are called *majority carriers* because they are primarily responsible for the current flow. Holes are called *minority carriers* because they conduct a much smaller current.

In P materials the opposite is true. Holes (or positive charges) are the primary current carriers. Electrons are minority carriers, conducting a much smaller current flow.

Semiconductor Devices

As the application of semiconductor devices expands throughout the support equipment field, the requirement for a working knowledge of these devices becomes increasingly important. Because NEETS, Module 7, describes in detail the theory and application of many devices, only the diode, Zener diode, transistor, and the silicon-controlled rectifier (SCR) are covered here.

DIODES.—The basic function of the diode is to act as a rectifier (one-way valve for electricity). The diode is the simplest kind of semiconductor. Figure 7-2 shows how a diode conducts; view A shows the P junction and N junction mated together, and view B shows current flow from the battery to the N section of the diode. These negatively charged electrons repel the free negative electrons already there, forcing them toward the PN junction. At the same time, electrons are being withdrawn from the P section, creating new holes. The new holes repel the old ones, moving them toward the PN junction. The holes in the P section and the electrons in the N section move toward each other. As the holes and electrons meet at the junction, the electrons fall into the holes. This action continues as

long as the battery is pumping out. Notice that the ammeter is showing current flow.

In view C the battery has been reversed to show how a diode blocks current flow. The electrons are trying to enter the P section; the electrons in the N section move in the direction of current flow. Looking at view C, you can see there are no holes or electrons near the PN junction. Therefore, there can be no current flow. The holes move in the opposite direction away from the PN junction. No reading is shown on the meter. Remember that electrons can flow from N to P, but not from P to N.

The most important point to remember about the PN junction diode is its ability to offer very little resistance to current flow in the forward-bias direction, but maximum resistance to current flow when reverse biased. A good way of illustrating this point is by plotting a graph of the applied voltage versus the measured current. Figure 7-3 shows a plot of this voltage-current relationship (characteristic curve) for a typical PN junction diode.

To determine the resistance from the curve in this figure, you can use Ohm's law, where $R = E \div I$. For example, at point A the forward-bias voltage is 1 volt and the forward-bias current is 5 milliamperes. This represents 200 ohms of resistance ($1 \text{ volt} \div 5 \text{ mA} = 200 \text{ ohms}$). However, at point B the voltage is 3 volts and the current is 50 milliamperes. This results in 60 ohms of resistance for the diode. Notice that when the forward-bias voltage was tripled (1 volt to 3 volts), the current increased 10 times (5 mA to 50 mA). At the same time the forward-bias voltage increased, the resistance decreased from 200 ohms to 60 ohms. In other words, when forward bias increases, the junction

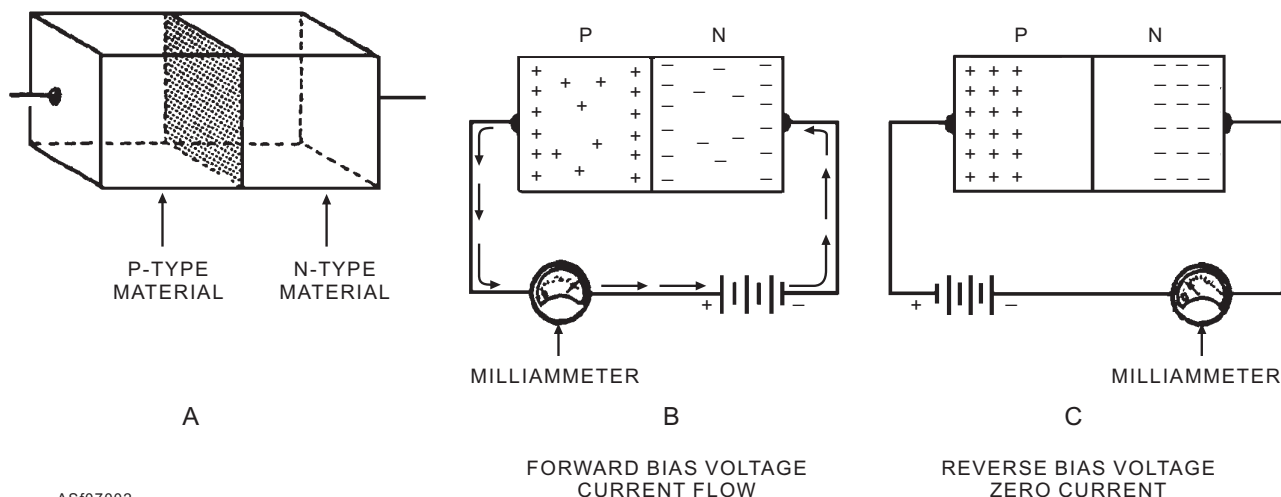

Figure 7-2.—Junction diode.

AS107002

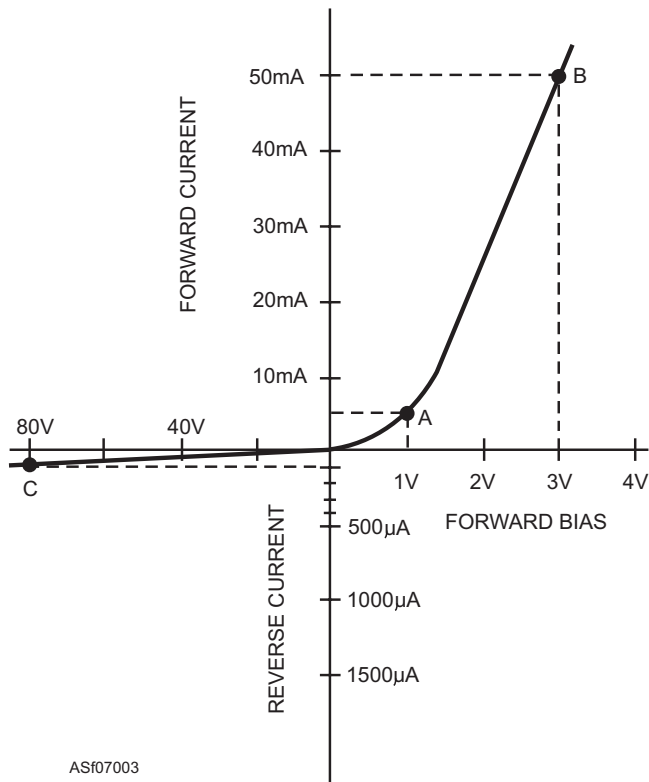

Figure 7-3.—PN junction diode characteristic curve.

barrier gets smaller, and its resistance to current flow decreases.

On the other hand, the diode conducts very little when reverse biased. Notice at point C the reverse bias voltage is 80 volts and the current is only 100 µA. This results in 800 kilohms of resistance, which is considerably larger than the resistance of the junction with forward bias. Because of these unusual features, the PN junction diode is often used to convert alternating current into direct current (rectification). Figure 7-4 illustrates various styles of PN diodes.

To test a diode, you use a multimeter or ohmmeter. Disconnect one of the diode leads from the circuit. Connect the meter to the diode's pigtailed. Figure 7-5 illustrates the test. You may or may not get a reading. Reverse the leads. If you had a low reading the first time, you should now have no reading or a high reading. A second low reading means the diode is shorted. Two high readings after reversing the leads means the diode is open. A low reading and high reading means the diode is good. One thing you should keep in mind about the ohmmeter check—it is not conclusive. It is still possible for a diode to check good under this test, but break down (temporarily fail) when replaced in the circuit. This can occur because the meter used to check the diode does not load the device as though it was in its operating circuit.

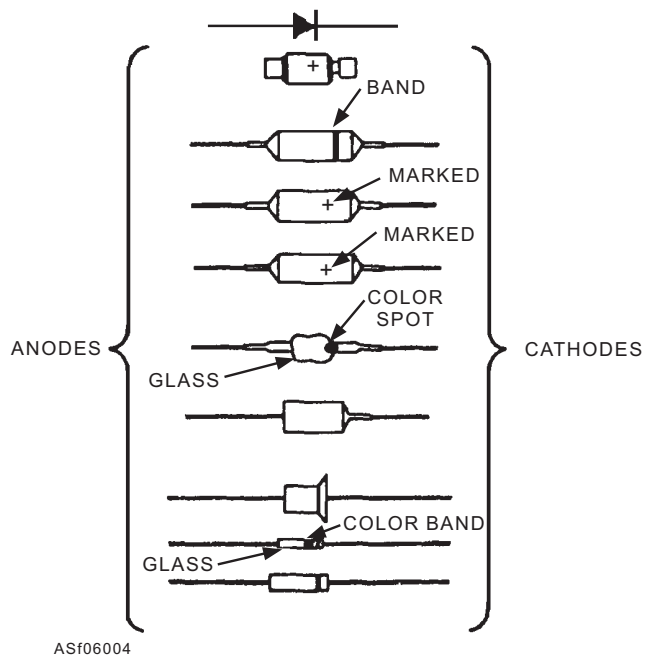
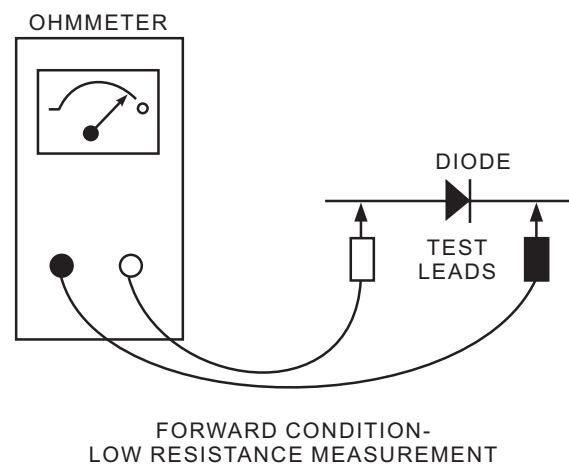
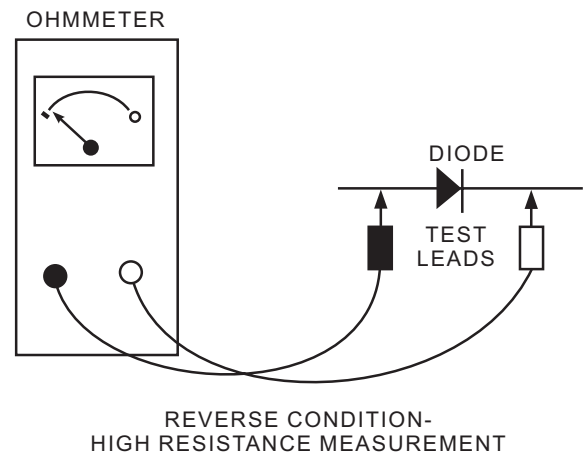

Figure 7-4.—PN diode identification.



ASF07005

Figure 7-5.—Checking a diode with an ohmmeter.

ZENER DIODES.—Zener diodes are special diodes, commonly referred to as voltage reference diodes. They are normally silicon rectifiers in which the reverse current remains small until the breakdown voltage is reached; it then increases rapidly without further increase in voltage. Each Zener diode is designed for a specific breakdown voltage. The breakdown voltage varies from a few volts to several hundred volts with different Zener diodes. A stabilized Zener diode output (voltage or current) can be supplied that is unaffected by temperature, output load, or input voltage within given limits. The stability of the Zener diode makes it very useful as a voltage reference.

Figure 7-6 shows a basic Zener diode dc voltage regulating circuit. A diode is selected that has a breakdown voltage equal to the desired regulated output voltage. A limiting resistor is then chosen. This resistor must drop the voltage difference between E_{IN} and E_{OUT} and maintain the Zener diode current at the correct operating value. When the input voltage rises or the load current decreases, current through the diode increases, and the voltage drop across R_1 increases so that the output voltage remains constant. Conversely, when the input voltage decreases or the load current increases, the diode current decreases and the voltage drop across R_1 decreases to maintain a constant output voltage.

A Zener diode is checked the same way a PN junction diode is checked.

TRANSISTORS.—Transistors are layers of N and P materials bound together. The NPN transistor is prepared by placing a narrow strip of P material between two wide strips of N material. One N section is called the *emitter* because electrons are extracted from the base; this section can emit electrons across the base. The other N section is called the *collector*, which is where the electrons are collected and passed down the circuit. The base is the area electrons are drawn from to permit current flow from one N section to another. Figure 7-7 shows an NPN transistor and its electronic symbol.

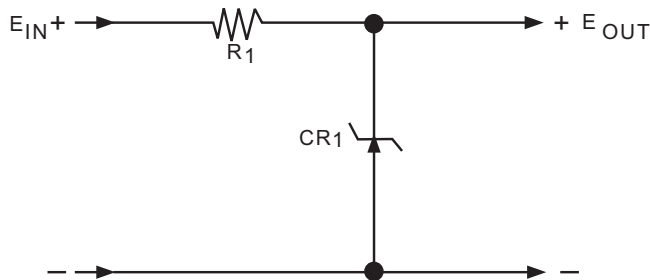
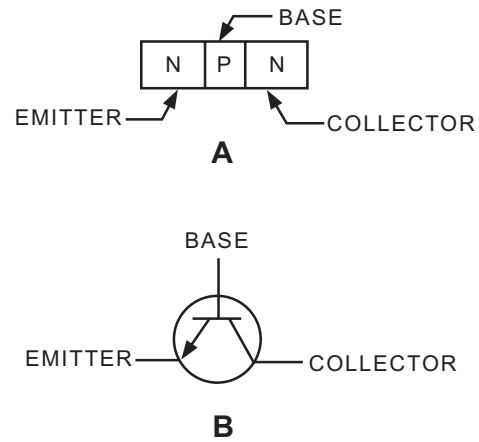

Figure 7-6.—Zener diode voltage regulating circuit.



ASf07007
Figure 7-7.—NPN transistor—(A) NPN diagram; (B) schematic symbol.

PNP transistors are just the opposite of NPN transistors. The N material is sandwiched between two strips of P material. Figure 7-8 shows the symbol for a PNP transistor. Notice that the emitter, base, and collector connections remain the same, but the arrow now points toward the base. An important point to remember on the schematic symbols for transistors is that the arrows point toward the N material.

In a PNP transistor, the emitter and collector (P material) are in positive holes, and the base (N material) has an excess of negative electrons.

How a Transistor Works.—Generally speaking, transistors do one of two things—they act as a amplifier or as a switching device. Although a transistor can either switch or amplify, normally it is made to do one job better than the other. For example, amplifiers have a stable, moderate current gain (degree of amplification). Most switching applications require fast turn-on and turn-off speeds and low leakage.

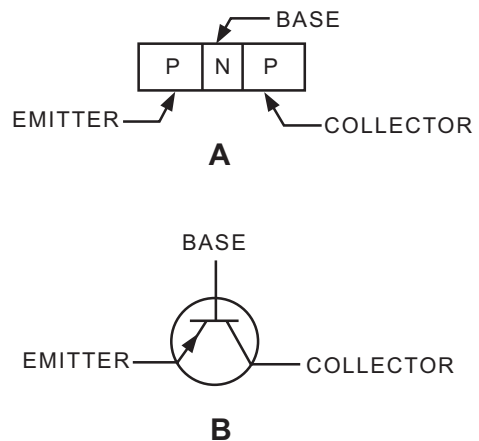

ASf07008
Figure 7-8.—PNP transistor—(A) PNP diagram; (B) schematic symbol.

Actually, what determines if the transistor acts as an amplifier or switch is the controlling circuit.

Figure 7-9 shows a circuit constructed by using an NPN transistor to amplify. The electrical control is provided by a microphone; a device that produces fluctuating electrical current corresponding to fluctuating sound waves. The microphone can produce only a small amount of power, and if hooked directly to the loudspeaker, you probably wouldn't hear a sound. But with the simple circuit you see in this figure, the power is amplified at least 100 fold.

In the example, the microphone produces a maximum of 0.5 milliwatt of power (1 milliwatt = 1/1000 watt). The power in the main circuit produced by the battery, however, ranges from 0 to 500 milliwatts.

Suppose you create a sound wave that hits the microphone and produces an output of 3 milliwatts. The microphone pumps a surge of electrons from a lower voltage (the base) to a higher voltage (the emitter). As a result of the base current, a relatively large current then flows across the base region from the emitter to the collector, down the line and through the coil of the speaker. In this way the current flow through the speaker is controlled (or amplified) in exact proportion to the smaller microphone signal. The signal through the speaker might be 300 milliwatts. This means that the 3 milliwatts produced by the microphone has been amplified 100 times.

Consider a microphone with a 2-milliwatt sound wave. Fewer electrons flow in the control circuit, so fewer are drawn from the base region; the speaker output is only 200 milliwatts. Notice that the output is still amplified 100 times. At all times, almost precise proportions are maintained between the control circuit and the working circuit. In other words, the power in the working circuit is always an essential duplicate of the power in the control circuit, but greatly amplified.

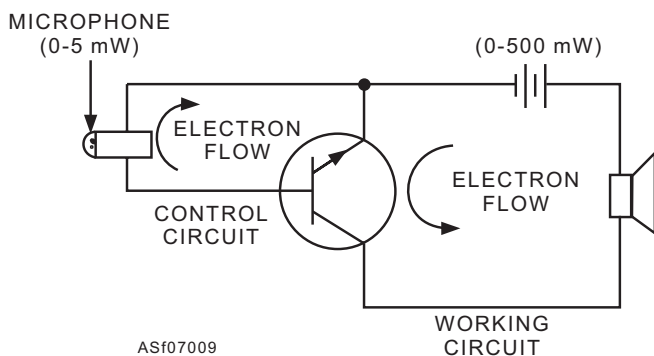

Figure 7-9.—Basic amplifying circuit.

Figure 7-10 shows a circuit designed as a switch. To make this circuit realistic, the buzzer is located a great distance from the switch. Since the switch (unlike our microphone) produces no power, a battery has been added to the control circuit. Because of the distance to the buzzer and the resistance in the connecting wires, the battery power in the controlling circuit is not great enough to activate the buzzer. But the surviving power does provide enough energy to operate a transistor.

When the switch is closed, a small current of electrons is withdrawn from the transistor base, a much greater current flows in the working circuit, and the buzzer sounds. This transistor is acting as a switch in the working circuit.

Transistor Testing.—There are several different ways of testing transistors. They can be tested while in the circuit with a transistor tester or an ohmmeter.

Transistor testers are nothing more than the solid-state equivalent of electron-tube testers (although they do not operate on the same principle). With most transistor testers, it is possible to test the transistor in or out of the circuit.

Because it is impractical to cover all of the different types of transistor testers and since each tester comes with its own operator's manual, we will move on to something you use more frequently for testing transistors—the ohmmeter.

There are four basic tests required for transistors in practical troubleshooting: gain, leakage, breakdown, and switching time. For maintenance and repair, however, it is usually not necessary to check all of these parameters. A check of two or three parameters is usually sufficient to determine whether a transistor needs to be replaced. Two of the most important parameters used for testing are gain and leakage.

A basic transistor gain test can be made by using an ohmmeter and a simple test circuit. The test circuit can be made with just a couple of resistors and a switch, as shown in figure 7-11. The principle behind

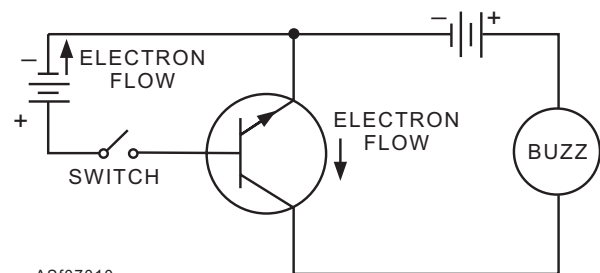

Figure 7-10.—Simple circuit using a transistor as a switch.

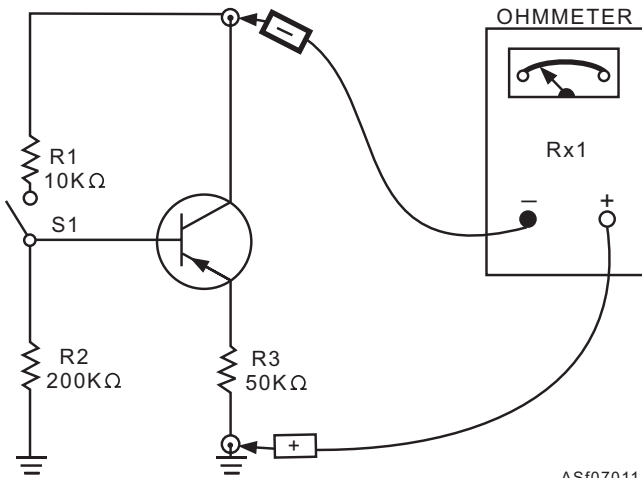

Figure 7-11.—Testing a transistor's gain with an ohmmeter.

the test lies in the fact that little or no current flows in a transistor between emitter and collector until the emitter-base junction is forward biased.

CAUTION

Ensure that the output of the tester does not exceed the maximum collector-emitter breakdown voltage of the transistor.

With the switch in the open position, as shown in figure 7-11, no voltage is applied to the PNP transistor's base; thus, the emitter-base junction is not forward biased. Therefore, the ohmmeter should read a high resistance, as indicated on the meter. When the switch is closed, the emitter-base circuit is forward biased by the voltage across R1 and R2. Current now flows in the emitter-collector circuit. This causes a lower resistance reading on the ohmmeter. A 10 to 1 resistance ratio in this test between meter readings indicates a normal gain for an audio-frequency transistor.

To test an NPN transistor by using this circuit, simply reverse the ohmmeter leads and carry out the procedure described earlier.

An ohmmeter can be used to test for transistor leakage (an undesirable flow of current) by measuring the base-emitter, base-collector, and collector-emitter forward and reverse resistances.

In each view of figure 7-12, consider the transistor under test as two diodes connected back to back. Each diode has a low-forward resistance and a high-reverse resistance. By measuring these resistances with an ohmmeter, as shown in the figure, you can determine if the transistor is leaking current through its junctions.

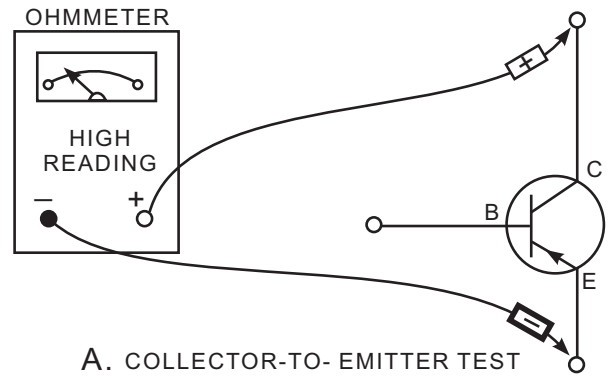

A. COLLECTOR-TO-EMITTER TEST

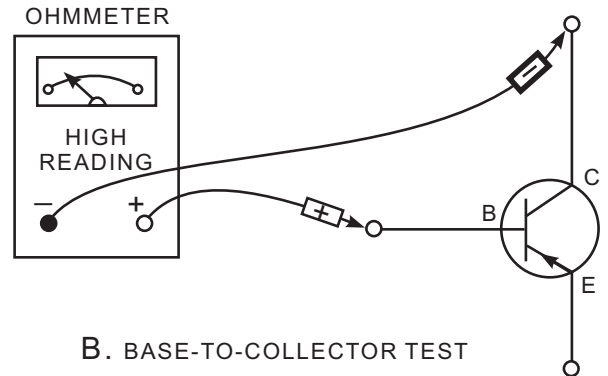

B. BASE-TO-COLLECTOR TEST

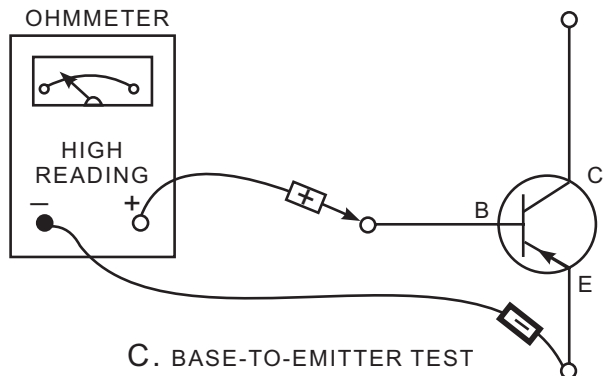

C. BASE-TO-EMITTER TEST

NOTE: REVERSING THE METER LEADS GIVES A LOW READING

ASf07012

Figure 7-12.—Testing a transistor's leakage with an ohmmeter.

CAUTION

When making these measurements, avoid using the R × 1 scale on the meter or a meter with a high internal battery voltage. Either of these conditions can damage a low-power transistor.

Now consider the possible transistor problems that could exist if the indicated readings are not obtained. A list of these problems is shown in table 7-1.

Table 7-1.—Transistor Problems

RESISTANCE READING		PROBLEM
FORWARD	REVERSE	The transistor is:
	Low (not shorted)	Leaking
Low (shorted)	Low (shorted)	Shorted
High	High	Open
Nearly Equal	Nearly Equal	Defective

By now, you should recognize that the transistor used in figure 7-12 is a PNP transistor. If you wish to test an NPN transistor for leakage, the procedure is identical to that used for testing the PNP, except the readings obtained are reversed.

When testing transistors (PNP or NPN), you should remember that the actual resistance values depend on the ohmmeter scale and the battery voltage. Typical forward and reverse resistances are insignificant. The best indicator for showing whether a transistor is good or bad is the ratio of forward-to-reverse resistance. If the transistor you are testing shows a ratio of at least 30 to 1, it is probably good. Many transistors show ratios of 100 to 1 or greater.

SILICON-CONTROLLED RECTIFIERS.—

The silicon-controlled rectifier (SCR) is a PNPN semiconductor switch, whose bi-stable action depends on regenerative internal feedback. Once this rectifier is turned on by a trigger voltage, it remains on until the supply voltage is removed. (See figure 7-13.)

The heart of a PNPN (SCR) device is its four-layer structure, which consists of alternate P- and N-type semiconductor material (fig. 7-13, view A). A PNPN structure is best visualized as consisting of two transistors, a PNP, and an NPN interconnected to form a regenerative feedback pair, as shown in view B of figure 7-13. The overall gain of the SCR is equal to the product of the gains of the two transistors. With proper voltage applied, the overall gain is less than one (unity). Under this condition, the SCR is said to be in its forward blocking or “off” state, and the only current flow in the device is leakage current. The “on” or conducting state of the SCR is initiated simply by raising the overall gain to one (unity). This gain increase is caused by applying a voltage (which may be a short duration voltage pulse) to the base of one of the transistors or “gate connection.” (See view C of figure

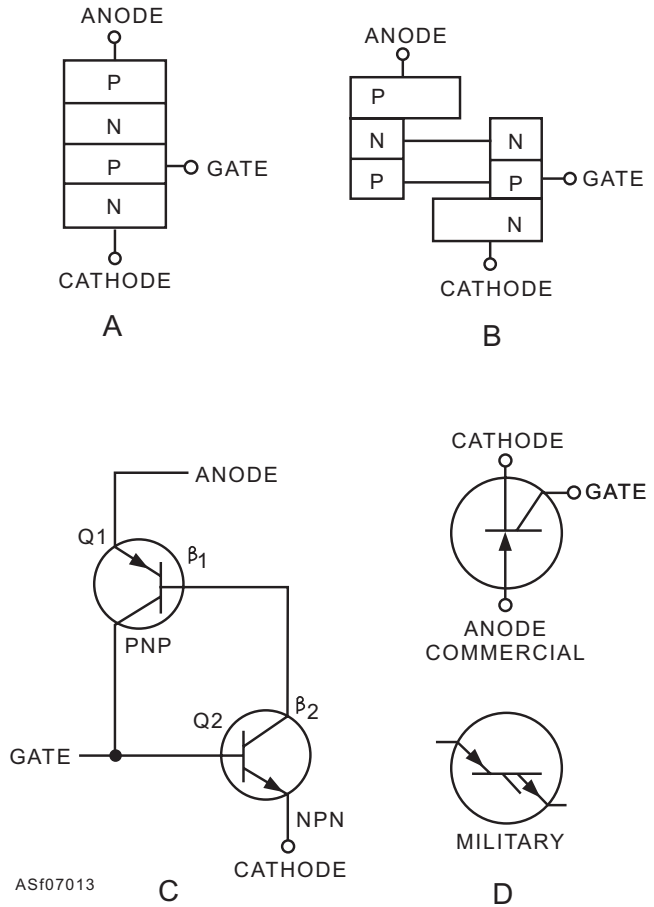

Figure 7-13.—Silicon-controlled rectifier—(A) physical PNPN structure; (B) two transistor analogy; (C) SCR internal circuitry; (D) SCR symbols.

7-13.) As the overall gain approaches one and the SCR starts to regenerate, each transistor drives its mate into saturation. Once in saturation, all junctions assume forward bias, and the voltage drop across the device becomes very low.

This type of device is used in applications where a very small “gate” voltage can be used to control high power requirements, such as main line power-contactor relays. The symbol for the SCR is shown in view D of figure 7-13.

MAGNETIC AMPLIFIERS

The advantage of the magnetic amplifier is that it is a completely static device. With the exception of the rectifiers normally used, its mechanical construction is comparable to that of an iron-core transformer. There are no moving contacts, moving parts, filaments, or other features that account for most of the failures associated with other types of amplifiers (except for those using transistors). A magnetic amplifier is essentially a device that controls the inductive reactance of a coil by using a dc signal voltage to

change the permeability of the magnetic material upon which the coil is wound.

Theory

To understand the theory of magnetic amplifiers, a knowledge of magnetism and magnetic circuits is necessary. To provide this knowledge, inductance and permeability are discussed in the following paragraphs, but only to the depth necessary to understand magnetic amplifiers.

INDUCTANCE.—Inductance is the property of an electric circuit that opposes any CHANGE IN THE CURRENT through a circuit. That is, if the current increases, a self-induced voltage opposes this change and delays the increase. If current decreases, a self-induced voltage tends to aid or prolong the current flow and delays the decrease. Inductance is caused by the buildup or collapse of a magnetic field around a conductor (fig. 7-14).

The current flow through a conductor always produces a magnetic field that surrounds the conductor. Therefore, even a perfectly straight conductor has some inductance. When the current flow changes, the magnetic field changes; an emf (electromotive force) or voltage is induced in the conductor to oppose the current change. These effects are summarized by Lenz's Law, which states that THE INDUCED EMF IN ANY CIRCUIT IS ALWAYS IN SUCH A DIRECTION AS TO OPPOSE THE EFFECT THAT PRODUCED IT. For all practical purposes, inductance has no effect on STEADY CURRENT (dc).

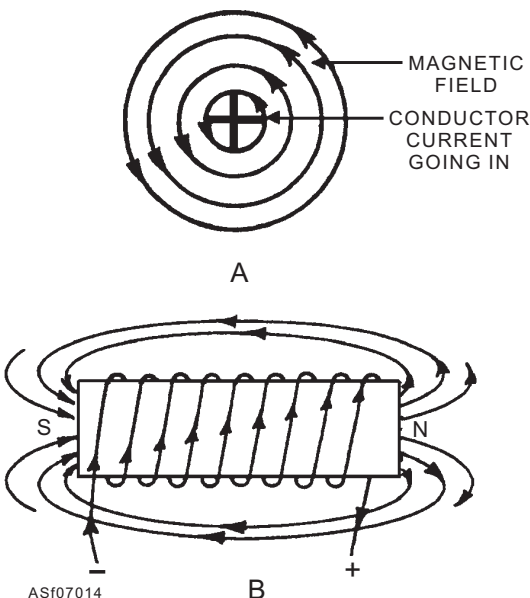

Figure 7-14.—Magnetic field of a current-carrying conductor.

The value of inductance that an inductor (coil) has depends on many things. Among them is the number of turns of wire, the ratio of the length of inductor to its diameter, and the material used in the core. Various formulas have been developed for calculating the self-inductance of inductors. The following formula is essentially correct and can be used to calculate self-inductance:

$$\frac{L + 1.256N^2 A\mu 0-8}{1}$$

where

L = inductance in henries

N = number of turns

A = area of the core in square centimeters

μ = permeability of the core material

l = length of the core in centimeters

From the foregoing formula, you can see that the permeability of the core of the inductor affects the inductance (opposition to current change) of the coil. A change in the permeability of the core is of concern to you as you study the magnetic amplifier.

PERMEABILITY.—The permeability (μ) of a substance is a measure of the ease with which it conducts magnetic lines of force when compared with air. When air is taken as the standard, its permeability is 1. On this basis, the permeability values of ferromagnetic materials, such as iron and steel, range from approximately 60 to 6,000.

Table 7-2 shows B, H, and μ for four common magnetic materials.

Permeability of magnetic materials decrease to nearly that of air if the current flow through the inductor is sufficient to saturate (completely magnetize) the core material. The relationship of permeability to magnetization can be seen in view A and B of figure 7-15.

Basic Magnetic Amplifier

A magnetic amplifier consists of a controlled variable inductance in series with an ac power supply and the load. The control action involves changes in the magnetic permeability of the inductance coil with resulting changes in inductance, inductive reactance, and impedance of the load circuit. As a result, changes are made in the current flowing in the load and the voltage available from the output.

Table 7-2.—B, H, and μ for Common Magnetic Materials

B	Sheet steel		Cast steel		Wrought iron		Cast iron	
	H		H		H		H	
3,000	1.3	2,310	2.8	1,070	2.0	1,500	5.0	600
4,000	1.6	2,500	3.4	1,177	2.5	1,600	8.5	471
5,000	1.9	2,630	3.9	1,281	3.0	1,666	14.5	347
6,000	2.3	2,605	4.5	1,332	3.5	1,716	24.0	250
7,000	2.6	2,700	5.1	1,371	4.0	1,750	38.5	182
8,000	3.0	2,666	5.8	1,380	4.5	1,778	60.0	133
9,000	3.5	2,570	6.5	1,382	5.0	1,800	89.0	101
10,000	3.9	2,560	7.5	1,332	5.6	1,782	124.0	80.6
11,000	4.4	2,500	9.0	1,222	6.5	1,692	166.0	66.4
12,000	5.0	2,400	11.5	1,042	7.9	1,520	222.0	54.1
13,000	6.0	2,166	16.0	813	10.0	1,300	290.0	44.8
14,000	9.0	1,558	21.5	651	15.0	934	369.0	38.0
15,000	15.5	970	32.0	469	25.0	600
16,000	27.0	594	49.0	327	49.0	327
17,000	52.0	324	74.0	230	93.0	183
18,000	92.0	196	115.0	156	152.0	118
19,000	149.0	127	175.0	108	229.0	83
20,000	232.0	86	285.0	70

You can see that inductance of an air-core winding can be increased enormously by inserting a core made of ferromagnetic material. A very simple circuit is shown in figure 7-16 to illustrate the fundamental process of the magnetic amplifier. The iron core is moved in and out of the winding to alternately increase and decrease the effective permeability. This varies the inductance, and hence the inductive reactance in series with the load resistor. Inductive reactance is in opposition to current flow (comparable to resistance in a dc circuit). When the core is completely within the winding, the inductive reactance is maximum, and the voltage drop across the coil is a large fraction of the applied voltage. As a result, the load voltage is low and the current flow is minimum; remove the core from the coil and just the opposite takes place in the circuit.

Basic Circuit

The simple circuit shown in figure 7-16 has obvious deficiencies as a magnetic amplifier. It does show you that changing the permeability of the coil in series with the load affected both the current and voltage available to the load.

From your study of inductance and permeability, you will recall that permeability can be changed by magnetizing the core material. Therefore, you can replace the movable core with a fixed core and a control winding and achieve the same results.

The basic arrangement of components for controlling ac load power by means of a control winding is shown in figure 7-17. Two windings are required, both of which are wrapped on a common core. The control winding shown on the left is supplied from a dc source; the control current is adjusted by a potentiometer. It is the purpose of the control current to establish a flux in the core. The second coil, the load winding, is connected in series with an ac power source and the load resistance (in this case, a lamp).

With the circuit (fig. 7-17) operating on the knee of the magnetization curve (view A of figure 7-15) for that particular core material, a small increase in control current lowers the inductance of the load winding. This occurs because the degree of magnetization is shifted to a point on the curve where the slope approaches the horizontal. The permeability of the core material is thereby decreased (view B of fig. 7-15). This causes the inductive reactance of the load winding to decrease; the total load-circuit impedance falls off; and

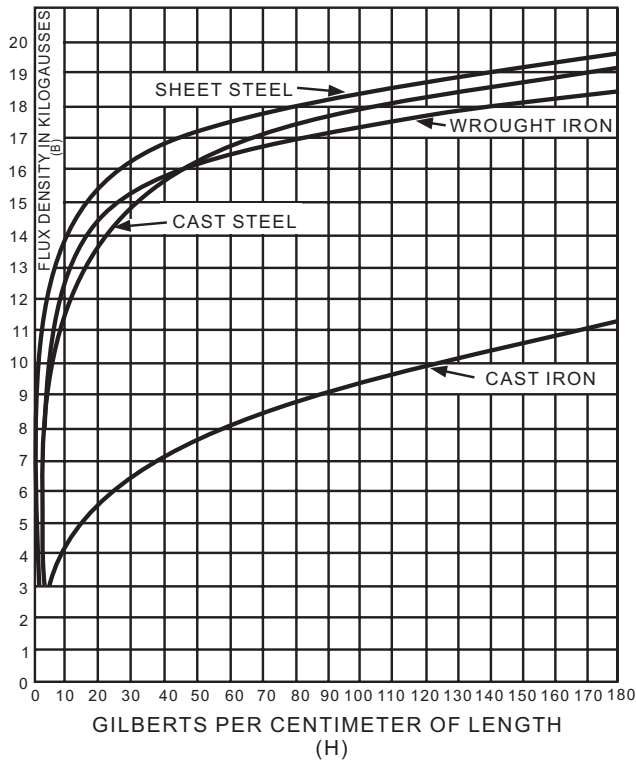

A

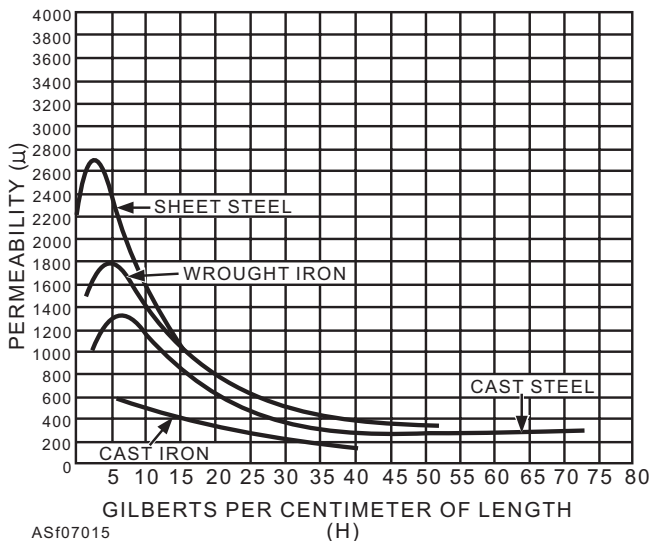

B

Figure 7-15.—Graph of four magnetic materials—(A) magnetization curves; (B) permeability curves.

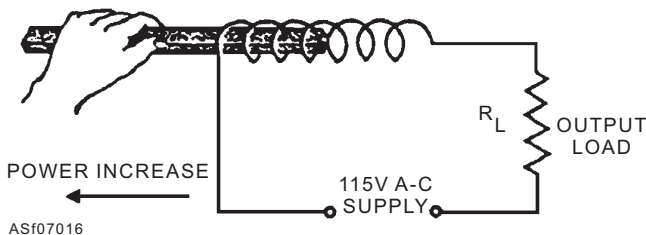

Figure 7-16.—Varying coil inductance mechanically.

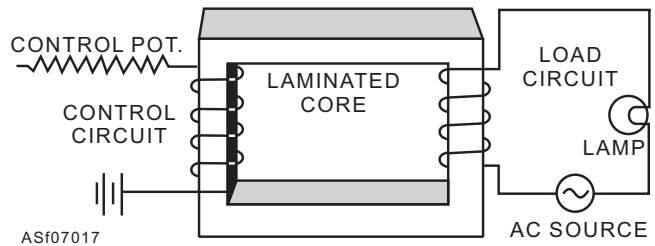

Figure 7-17.—A basic magnetic amplifier.

the load current increases, causing the power developed in the load to increase.

If control current increases enough to saturate the core completely, the load winding reactance drops nearly to zero. The resistances of the winding and of the load are the principal current limiting elements. In this condition, maximum voltage is applied to the load and the lamp glows at maximum brightness.

On the other hand, decreasing the control current causes an increase in the reactance of the load winding since the operating point is moved toward the steep part of the curve, increasing the permeability. This places the coil at a maximum value of load current and the minimum load power. Thus, for a small change in power, the magnetic action produces a large change in load power. This action causes the device to function as an amplifier.

Although the explanation just given illustrates a basic magnetic amplifier and the method of electrically controlling permeability, it is seldom used because it is a very inefficient magnetic amplifier. The problems of this amplifier are primarily caused by transformer action. Transformer action causes energy to be coupled from one winding to the other. The alternating flux, which results from load current, induces voltage into the control winding (refer back to figure 7-17). If the control winding has a large number of turns, the induced voltage may become excessive and may even break down the insulation. Even if the coupled voltage is small, the control circuit acts as a low-resistance winding and dissipates a considerable amount of energy that would normally be applied to the output.

Improved Magnetic Amplifier

A more satisfactory circuit arrangement results when the basic amplifier is modified, as shown in figure 7-18. This device is often employed for controlling large amounts of alternating current. It contains a three-legged core with an ac winding on each outer leg and a dc control winding on the center leg. The chief advantage of this core structure is that alternating flux components produced by currents in

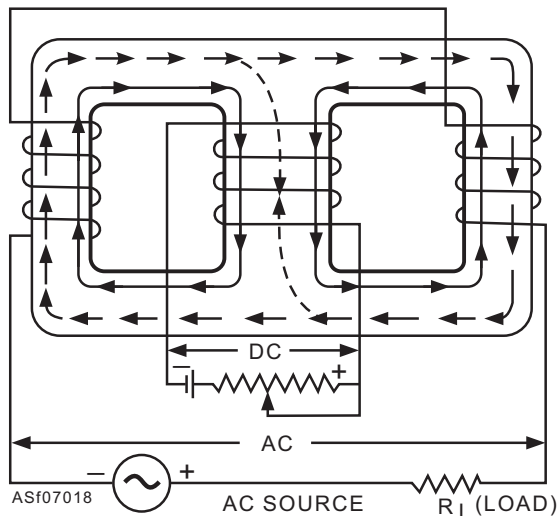

Figure 7-18.—Magnetic amplifier with three-legged core.

the load windings are balanced out in the center leg and do not affect the control circuit.

While alternating flux does not pass effectively through the center leg, the two components add along the path through the outer legs of the core, as indicated by the broken lines. The drawing also shows that the control current produces a magnetic flux (represented by solid lines) that magnetizes the entire core of each load winding. In this arrangement, the dc coil can influence the operation of the load circuit. There is no coupling of energy by transformer action from the load circuit to the control winding.

During normal operation, variations of the control current result in corresponding changes in core permeability; this readjusts the inductive reactance in series with the load. The operational control process of this amplifier is very similar to that of the basic magnetic amplifier.

The efficiency of this magnetic amplifier can be further improved by the use of rectifiers and bias windings. The rectifiers are used to eliminate the alternating flux in the core caused by the load current. The bias winding is used to preset a magnetic flux in the core material. This aids the control winding in controlling the permeability of the core.

APPLICATION OF SEMICONDUCTOR DEVICES AND MAGNETIC AMPLIFIERS

The magnetic amplifier and semiconductor devices have found widespread use in many different types of circuits. Circuits using these components may be found in voltage regulators, servo amplifiers, and audio amplifiers. You are mainly concerned with their application in voltage regulators.

Figure 7-19 shows a typical solid-state voltage regulator, using diodes, Zener diodes for voltage sensors, and the magnetic amplifier.

At the start, generator voltage is zero and relays K1 and K2 are in the positions shown. During the initial buildup of voltage, the residual dc output of the exciter armature is connected directly to the exciter control field through terminal A+ and K2, through the lower winding of stabilizer transformer T4, and then through F+ to the field. This causes a rapid buildup of ac output voltage through T1, T2, T3, and through the primary winding of T6. When line voltage rises to a near-normal level, the output of CR1 is sufficient to actuate relays K1 and K2. With the contacts of K2 pulled down, exciter output no longer goes directly to the exciter control field, but instead goes through a current limiting resistor, T5 to A-. It is used thereafter as a stabilizer reference for normal operation. With the contacts of K1 pulled down, the output of T6's secondary is routed through the load windings 3-4 of the magnetic amplifier L1 to rectifier CR2. The output

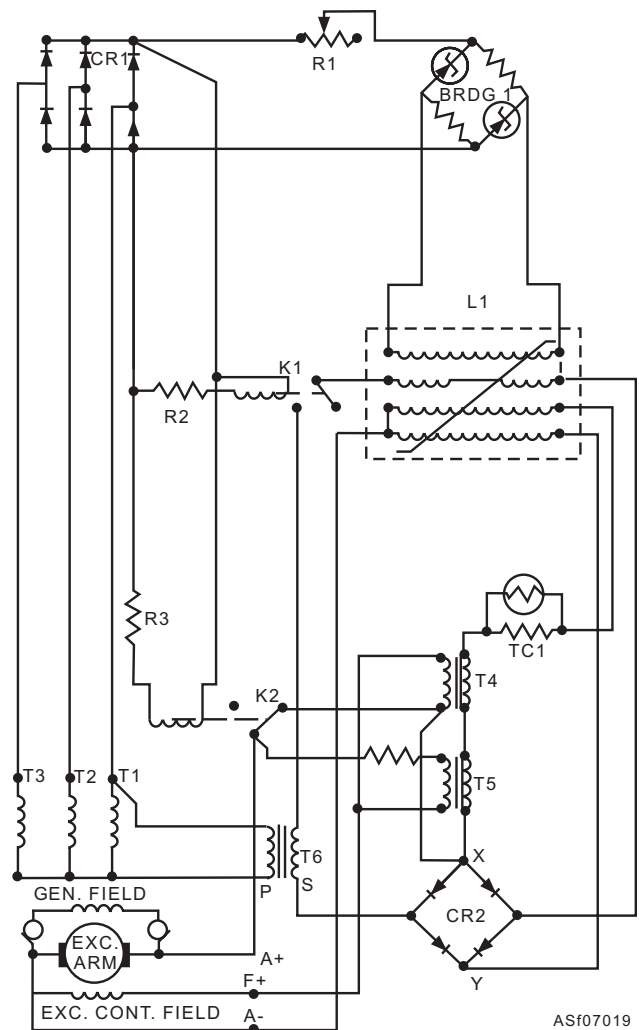

Figure 7-19.—Typical solid-state regulator.

of T6 is rectified by CR2; the dc is routed from terminal X on CR2 through the lower winding of T4 to F+ and the field.

The amount of power T6 may provide to the exciter field is governed by the impedance of the series load windings 3-4 in L1. The impedance of load windings 3-4 is, in turn, regulated by the bridge-powered dc control winding 1-2 in L1.

The complete voltage regulating loop can now be seen. AC line voltage at T1, T2, and T3 acts through CR1 and BRDG 1 into the control field of the magnetic amplifier. This governs the output of T6 through L1, CR2, and lower winding T4 into the exciter control field. The exciter control field then regulates the exciter armature voltage, thereby controlling generator field strength, and finally the ac output at T1, T2, and T3.

The other path for dc from terminal X of CR2 is through T4, T5, temperature-compensator TC1, down through L1's winding 5-6, upward through winding 8-7, and back to the rectifier source, terminal Y. This circuit is used to bias the magnetic amplifier at the proper operating level.

Voltage adjustment of this regulator is done by positioning R1. This sets the bridge circuit BRDG 1, and, in turn, sets the ac line output voltage to 120, 117, etc. To understand the function of R1 and BRDG 1, refer to figure 7-20.

Figure 7-20 illustrates the primary features of a voltage-sensing bridge circuit. The line ac voltage is rectified to a nominal value of 200 volts dc and applied across a bridge consisting of R1, VR1, R2, and VR2. Resistors R1 and R2 are fixed resistors. Zener diodes VR1 and VR2 are used as the voltage reference points. They maintain a constant voltage drop across themselves of 100 volts. When line voltage is at the proper value, the dc bridge voltage is 200 volts. The ohmic value of R1 and R2 is such that their voltage drops are the same as the voltage drops of the Zener

diodes. Under these conditions, the bridge is balanced and no current flows between points X and Y through the control winding (CW). In view B, line voltage has risen to 210 volts. Since the voltage drop across VR1 and VR2 cannot change, the increase of applied voltage alone has caused an imbalance to the bridge; current flows from X to Y through CW. In view C, where line voltage drops to 190 volts, the Zener diodes continue to have voltage drops of 100 volts. The decrease of applied voltage appears across R1 and R2; the bridge is again unbalanced but in the opposite direction. This causes current to flow from Y to X through CW.

You can see that the essential function of the bridge is to translate a variation of line voltage into a current through the control winding.

Q7-1. What are the two types of materials used to make semiconductors?

1. Silicon and Titanium
2. Titanium and plastic
3. Germanium and Silicone
4. Germanium and plastic

Q7-2. Which of the following components is considered to be the simplest kind of semiconductor?

1. A transistor
2. A diode
3. A Zener diode
4. A silicone-controlled rectifier

Q7-3. Which of the following components is commonly referred to as a voltage reference diode?

1. A Zener diode
2. A regulator diode
3. A NPN diode
4. A PNP diode

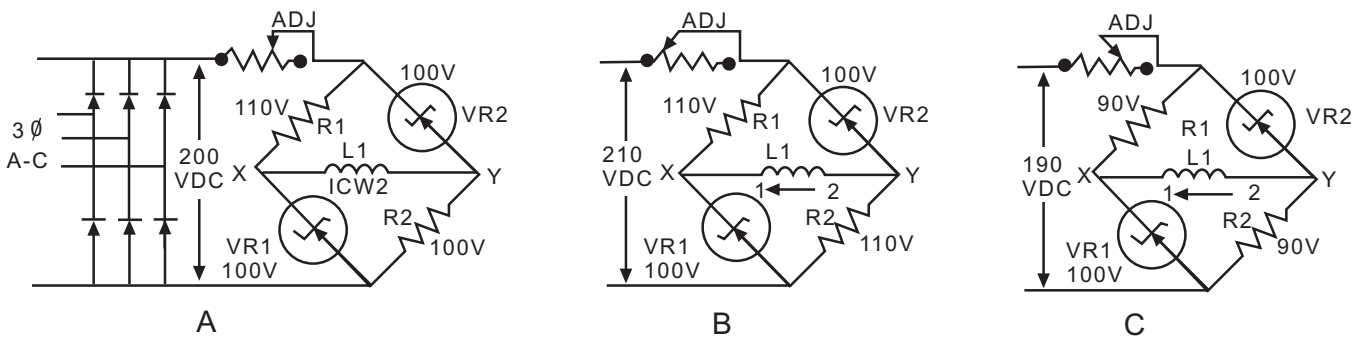

Figure 7-20.—Views of line voltage-sensing bridge (BRDG).

Q7-4. Which of the following components can act as a amplifier or a switching device?

1. A silicone-controlled rectifier
2. A Zener diode
3. A bridge rectifier
4. A transistor

Q7-5. Which of the following statement best describes a silicon-controlled rectifier?

1. It will stop conducting when the gate voltage is removed
2. It will begin to conduct when a voltage is applied to the emitter
3. A very small gate voltage can be used to control high-power requirements
4. A difference in potential is required between the base and emitter for it to conduct

Q7-6. A magnetic amplifier uses what type of voltage to change the permeability of the magnetic material upon which the coil is wound?

1. A pulsating ac voltage
2. A dc signal voltage
3. A rectified ac voltage
4. A pulsating dc voltage

Q7-7. Which of the following statements best describes the term permeability?

1. The ability of a substance to allow current flow
2. The ease with which a substance will conduct voltage
3. The ability of a substance to become saturated with magnetic lines of force
4. The ease with which a substance conducts lines of force when compared with air

GENERATORS

LEARNING OBJECTIVE: Recognize the operating characteristics of ac and dc generators used in power generating equipment.

A generator is a machine that converts mechanical energy into electrical energy by using the principle of magnetic induction. The principle of magnetic induction is based on the theory that whenever a conductor is moved within a magnetic field in such a

way that the conductor cuts across magnetic lines of force, voltage is generated in the conductor. The amount of voltage generated depends on the following:

- The strength of the magnetic field
- The angle at which the conductor cuts the magnetic field
- The speed at which the conductor is moved
- The length of the conductor within the magnetic field

The POLARITY of the voltage depends on the direction of the magnetic lines of flux and the direction of movement of the conductor. To determine the direction of current in a given situation, use the LEFT-HAND RULE FOR GENERATORS.

Extend the thumb, forefinger, and middle finger of your left hand at right angles to one another, as shown in figure 7-21. Point your thumb in the direction the conductor is being moved. Point your forefinger in the direction of magnetic flux (from north to south). Your middle finger will then point in the direction of current flow in an external circuit to which the voltage is applied.

In figure 7-22 assume the conductor between A and B, when moved, cuts the lines of force. This motion induces a voltage between A and B. Because the conductor completes the circuit, current flows, and a voltage shows on the voltmeter. The voltage amount depends on the following three factors:

- The strength of the magnetic field

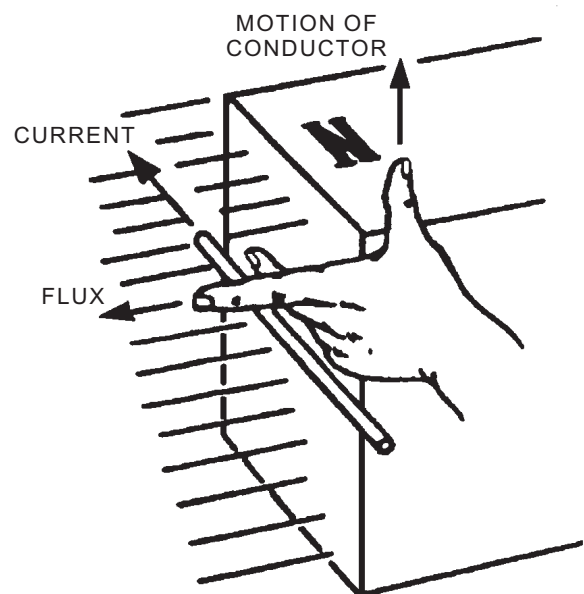

ASf07021

Figure 7-21.—Left-hand rule for generators.

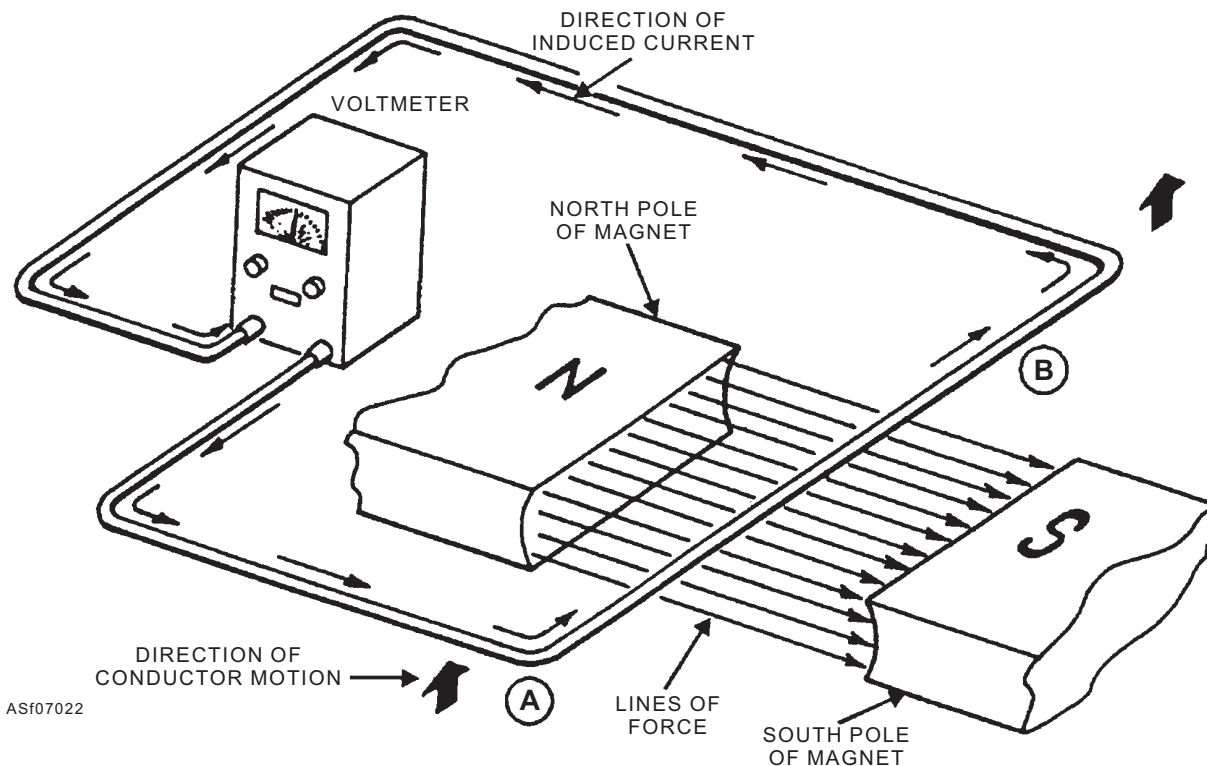

ASf07022

Figure 7-22.—Electromagnetic induction principles.

- The speed the conductor is moved
- The length of the conductor

The increase of any of these factors causes the induced voltage to increase. Also, remember that the voltage induced is greater when the conductor moves at right angles to the force lines.

In figure 7-23 various angles are shown along with the induced voltage produced. The armature loop is rotated in a clockwise direction. Its initial or starting position is shown in part A. (This is considered the zero-degree position.) At 0° the armature loop is perpendicular to the magnetic field. The black and white conductors of the loop are moving parallel to the

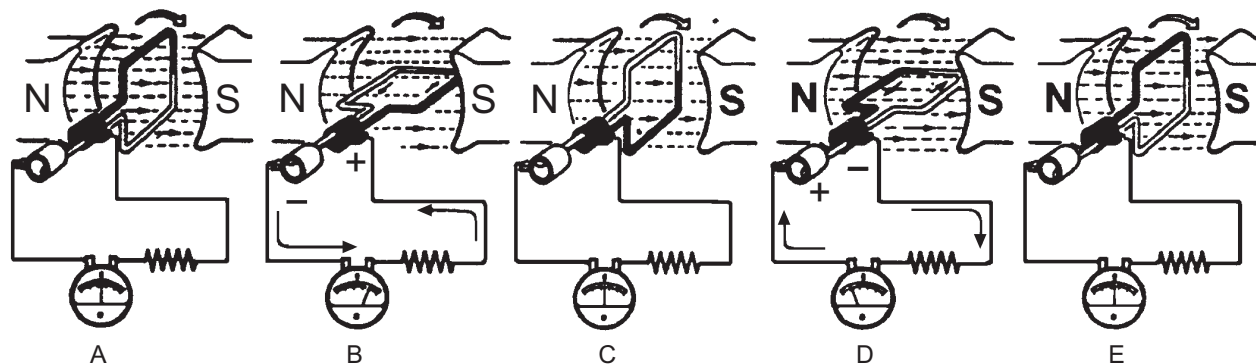

ASf07023

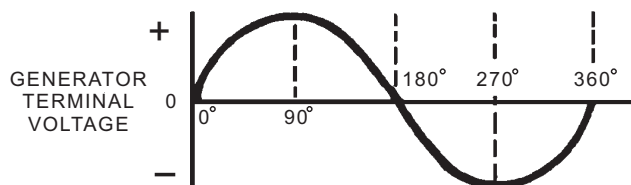

Figure 7-23.—Output voltage of an elementary generator during one revolution.

field. At the instant the conductors are moving parallel to the magnetic field, they do not cut any lines of force. Therefore, no electromotive force (emf) is induced in the conductors; the meter in part A indicates zero. This position is called the *NEUTRAL PLANE*. As the armature loop rotates from position A to position B, the conductors cut through more and more lines of force at a continually increasing angle. At 90° (position B), they are cutting through a maximum number of lines of force and at a maximum angle. The result is that between 0° and 90° , the induced emf in the conductor builds up from zero to a maximum value. Observe that from 0° to 90° the black conductor cuts DOWN through the field. At the same time the white conductor cuts UP through the field. The induced emf in the conductors are series-adding. This means the resultant voltage across the brushes (the terminal voltage) is the sum of the two induced voltages. The meter at position B reads maximum value.

As the armature loop continues to rotate from position B (90°) to position C (180°), the conductors that were cutting through a maximum number of lines of force at position B now cut through fewer lines. At position C they are again moving parallel to the magnetic field. They no longer cut through any lines of force. As the armature rotates from 90° to 180° , the induced voltage decreases to zero in the same manner as it increased from 0° to 90° . The meter again reads zero. From 0° to 180° , the conductors of the armature loop moved in the same direction through the magnetic field. Therefore, the polarity of the induced voltage remained the same. This is shown by positions A through C. As the loop starts rotating beyond 180° , from position C, through D, to position A, the direction of the cutting action of the conductors through the magnetic field reverses. Now the black conductor cuts UP through the field. The white conductor cuts DOWN through the field. As a result, the polarity of the induced voltage reverses. If you follow the sequence shown in positions C through D and back to position A, the voltage is in the direction opposite to that shown from positions A, B, and C. The terminal voltage is the same as it was from A to C, except for its reversed polarity (as shown by meter deflection in D). The voltage output waveform for the complete revolution of the loop is as shown on the graph.

Regardless of size, all electrical generators, whether dc or ac, depend upon the principle of

magnetic induction. An emf is induced in a coil as a result of

- A coil cutting through a magnetic field, or
- A magnetic field cutting through a coil.

As long as there is relative motion between a conductor and a magnetic field, a voltage is induced in the conductor. That part of a generator that produces the magnetic field is called the *field*. That part in which the voltage is induced is called the *armature*. For relative motion to take place between the conductor and the magnetic field, all generators must have two mechanical parts—a rotor and a stator. The rotor is the part that rotates; the stator is the part that remains stationary. In a dc generator, the armature is always the rotor. In ac generators, the armature may be either the rotor or stator.

A generator that produces alternating current is called an *ac generator* (alternator). One that produces a direct current is called a *dc generator*. However, both types operate by the induction of an ac voltage in the coils (conductors). The major difference between an ac generator and a dc generator is in the method by which the electrical energy is connected and applied to the external circuit.

Automotive ac generators are normally called *alternators*. But, when used to supply external power on the MEPPs, they are usually called *ac generators*. The ac generators used on the MEPP are usually larger in size, heavier in weight, and have a heavier power output than the automotive type.

DC GENERATORS

A dc generator is similar to an ac generator with one major exception. An ac generator has slip rings, while a dc generator has commutator segments.

The purpose of the commutator is to rectify the ac waveform. The segments of the commutator are insulated from each other and the armature shaft. Wires from the armature are connected to the commutator segments. Armature current is conducted from the commutator to the load by carbon brushes.

Figure 7-24 shows a graph of the output of a simple dc generator. This waveform is for a simple dc generator, one that has only a single coil armature and a two-section commutator. It is not the waveform generated by a practical dc generator, which should produce output with very little fluctuation. To help produce a smoother dc output, more coils and

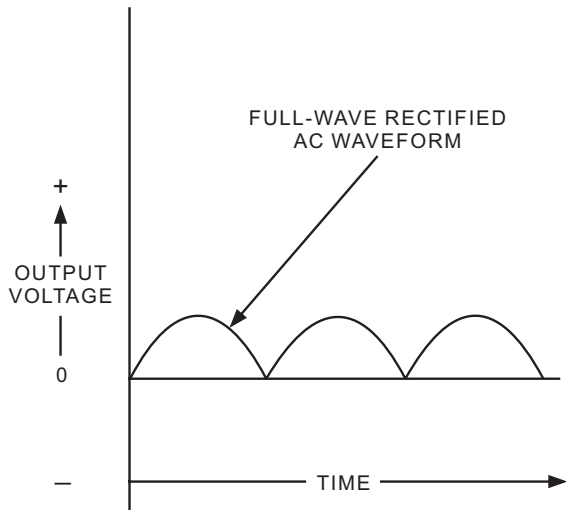

ASf07024

Figure 7-24.—Graph of the output of a simple dc generator.

commutator segments are used. The coils are insulated from each other, the same as the commutator segments. Figure 7-25 shows the output of a two-coil generator. This output is the combination of the two individual outputs produced by the individual coils. Note that the waveform is smoother but still fluctuates. To get the waveform still smoother, more coils must be added. In some cases filters are used to smooth out the voltage. These include capacitors and inductors.

Field Excitation

When a dc voltage is applied to the field windings of a dc generator, current flows through the windings and sets up a steady magnetic field. This is called *FIELD EXCITATION*.

This excitation voltage can be produced by the generator itself or it can be supplied by an outside source, such as a battery. A generator that supplies its own field excitation is called a *SELF-EXCITED GENERATOR*. Self-excitation is possible only if

the field pole pieces have retained a slight amount of permanent magnetism called *RESIDUAL MAGNETISM*. When the generator is put in motion, the weak residual magnetism causes a small voltage to be generated in the armature. This small voltage applied to the field coils causes a small field current. Although small, this field current strengthens the magnetic field and allows the armature to generate a higher voltage. The higher voltage increases the field strength, and so on. This process continues until the output voltage reaches the rated output of the generator.

Classification of Self-Excited Generators

Self-excited generators are classified according to the type of field connection they use. There are three general types of field connections—*SERIES-WOUND*, *SHUNT-WOUND* (parallel), and *COMPOUND-WOUND*. Compound generators are further classified as *cumulative-compound* and *differential-compound*; however, these last two classifications are not discussed in this course.

SERIES-WOUND GENERATORS.—In the series-wound generator, view A of figure 7-26, the field windings are connected in series with the armature. Current that flows in the armature flows through the external circuit and through the field windings. The external circuit connected to the generator is called the *load circuit*.

A series-wound generator uses very low-resistance field coils, which consist of a few turns of large diameter wire.

The voltage output increases as the load circuit starts drawing more current. Under low-load current conditions, the current that flows in the load and through the generator is small. Since small current

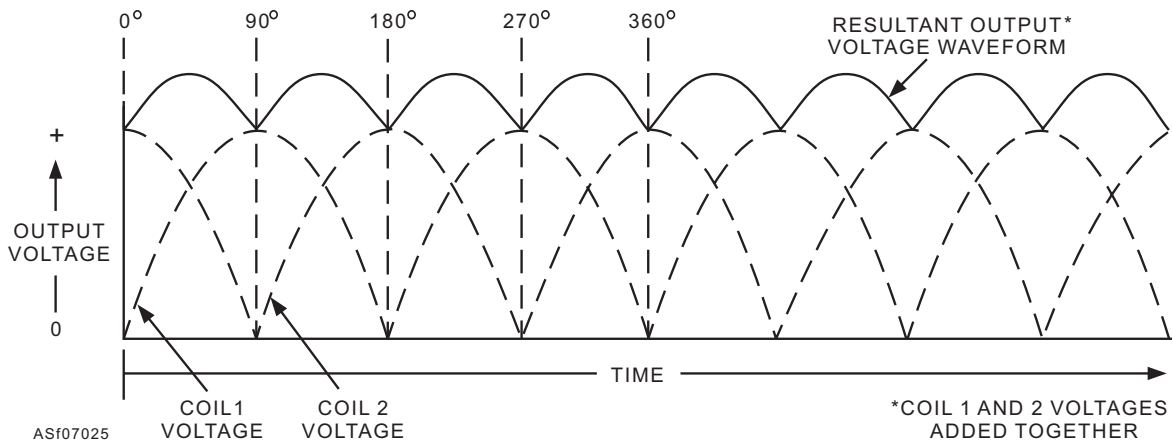

ASf07025

Figure 7-25.—Results of additional coil.

means that a small magnetic field is set up by the field poles, only a small voltage is induced in the armature. If the resistance of the load decreases, the load current increases. Under this condition, more current flows through the field. This increases the magnetic field and increases the output voltage. In a series-wound dc generator, the output voltage varies with load current. This is undesirable in most applications. For this reason, this type of generator is rarely used in everyday practice.

SHUNT-WOUND GENERATORS.—In a shunt-wound generator, like the one shown in view B of figure 7-26, the field coils consist of many turns of small wire. They are connected in parallel with the load. In other words, they are connected across the output voltage of the armature.

Current in the field windings of a shunt-wound generator is independent of the load current (currents

in parallel branches are independent of each other). Since field current, and therefore field strength, is not affected by load current, the output voltage remains more nearly constant than does the output voltage of the series-wound generator.

In actual use, the output voltage in a dc shunt-wound generator varies inversely as load current varies. The output voltage decreases as load current increases because the voltage drop across the armature resistance increases ($E = IR$).

As you have seen, the effect of load current variation of field strength does not cause voltage variation in the shunt-wound generator. However, voltage across the armature varies inversely with the current.

In a series-wound generator, output voltage varies directly with load current. In the shunt-wound generator, output voltage varies inversely with load

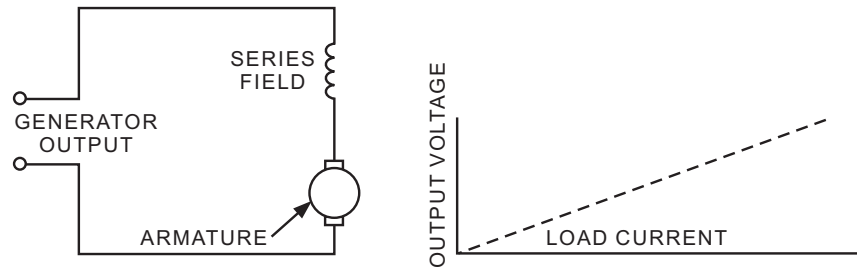

A. SERIES-WOUND DC GENERATOR

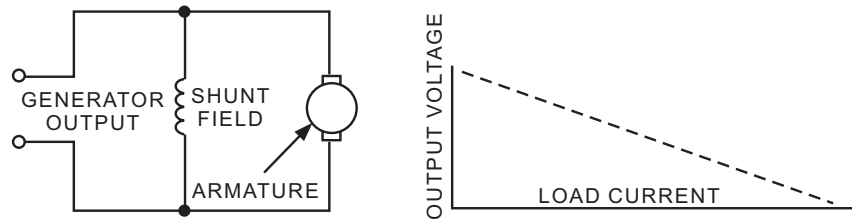

B. SHUNT-WOUND DC GENERATOR

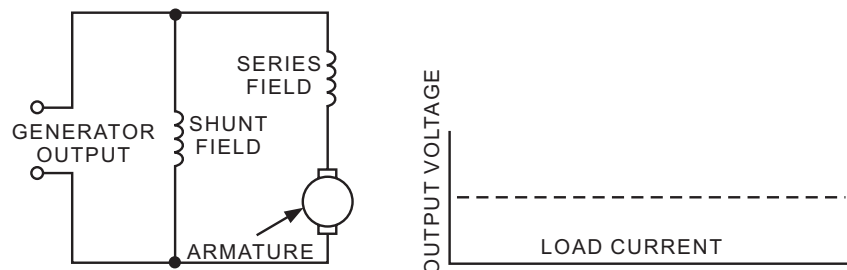

C. COMPOUND-WOUND DC GENERATOR

ASf07026

Figure 7-26.—Voltage output characteristics of the series, shunt, and compound-wound generators.

current. A combination of the two types can overcome the disadvantages of both. This combination of windings is called the *compound-wound dc generator*.

COMPOUND-WOUND GENERATORS.—

Compound-wound generators have a series-field winding in addition to a shunt-field winding, as shown in view C of figure 7-26. The shunt and series windings are wound on the same pole pieces.

When load current increases in the compound-wound generator, the armature voltage decreases just as in the shunt-wound generator. This causes the voltage applied to the shunt-field winding to decrease, which results in a decrease in the magnetic field. This same increase in load current, since it flows through the series winding, causes an increase in the magnetic field produced by that winding.

By proportioning the two fields so that the decrease in the shunt field is just compensated by the increase in the series field, the output voltage remains constant. As you can see, by proportioning the effects of the two fields (series and shunt), a compound-wound generator provides a constant output voltage under varying load conditions. Actual curves are seldom, if ever, as gradual as shown.

DC Voltage Regulators

Dc voltage regulators are used to maintain a constant generator voltage output despite variations in generator speed and load conditions. The voltage

regulators used in current dc systems are solid-state electronic units. The voltage regulator governs the generator by sampling the output voltage and supplying the proper field excitation to maintain a constant 28-volt dc output. The following paragraphs explain the operation of a typical solid-state regulator.

Transistorized voltage regulators are rapidly replacing the older systems that use carbon pile and magnetic amplifiers. Solid-state regulators are more economical in original cost and repair. They are only a fraction of the weight of the older units.

The solid-state regulator, shown in figure 7-27, is a very basic system. It is designed to control the field voltage by using no mechanical components. This system uses an externally mounted voltage adjusting potentiometer. It is located on the generator instrument panel, in full vision of the operator. The voltage adjusting potentiometer can be used to increase the generator output, compensating for voltage drops during load conditions.

During normal operation, the voltage adjusting potentiometer is set for 28 volts. The generator output voltage is sensed at terminal A. The sensed voltage of the generator output is supplied through a voltage divider circuit. The voltage divider circuit includes R1, the external voltage adjusting potentiometer, and R7. The external voltage adjusting potentiometer is a variable resistor. The setting of this resistor determines the proportion of the generator voltage that can bias the base of transistor Q4. As the generator output voltage varies, the bias voltage from the external voltage

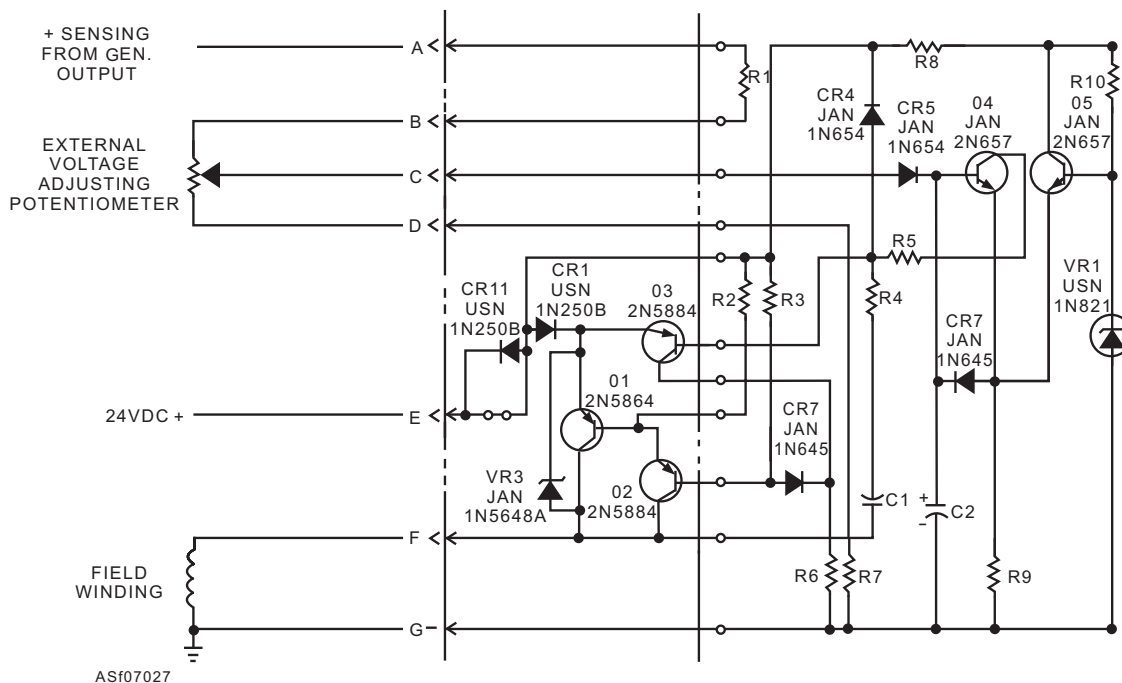

Figure 7-27.—Simplified solid-state dc voltage regulator.

adjusting potentiometer also varies. The divided generator voltage is applied to the base of Q4 and to capacitor C2. Diode CR5 blocks the capacitor's discharge. Q4 regulates the operation of transistor Q3 by varying its base voltage. The degree of conduction of transistor Q4 is determined by its base voltage and the difference in potential between that voltage and the reference voltage across R9. Transistor Q5 and the temperature compensated Zener diode VR1 provide the reference voltage across R9. CR7 links this reference voltage to capacitor C2 and the base of transistor Q4 when the reference voltage is higher than the sensed input. This limits the emitter to base potential during varying inputs.

Q4 controls the bias of Q3 by varying the base potential. When Q3 is cut off, maximum battery voltage is applied to the field winding by Q1 and Q2, a Darlington stage amplifier. When Q3 is saturated, a minimum voltage is applied to the field. The battery voltage is then dropped across the emitter-collector junction of Q3 and the collector resistor R6.

Now that the function of each major component has been explained, visualize their actions during a varying generator output.

As the generator output increases, sensed voltage applied to the base of Q4 by the voltage divider circuit also increases. This causes Q4 to conduct more. Q3 is driven into a higher conducting state. The voltage drop across the emitter and collector of Q3 biases the Darlington stages Q1 and Q2. The Darlington stage is then less conductive. This decreases the field voltage. As a result of a weaker field voltage, the generator's output is decreased. This decreasing action continues until the sensed voltage is reduced to the Zener reference potential.

When the generator voltage decreases, the base voltage of Q4 decreases. Q4 conducts less and causes Q3 to conduct less. The emitter voltage of Q3 becomes more positive, causing Q1 and Q2 to be more conductive. This increases the field voltages and current until the sensed voltage reaches the Zener reference potential. This action is repeated many times each second, providing a seemingly constant generator output.

AC GENERATORS

Many of the terms and principles covered in the following paragraphs are familiar to you. They are basically the same as those covered in the dc generator section.

There are two types of ac generators—rotating-armature and rotating-field.

Rotating-Armature Generators

The rotating-armature ac generator (alternator) is similar in construction to the dc generator in that the armature rotates in a stationary magnetic field, as shown in view A of figure 7-28. In the dc generator, the emf generated in the armature windings is converted from ac to dc by means of the commutator. In the ac generator, the generated ac is brought to the load unchanged by means of slip rings. The rotating armature is found only in generators of low power rating and generally is not used to supply electric power in large quantities.

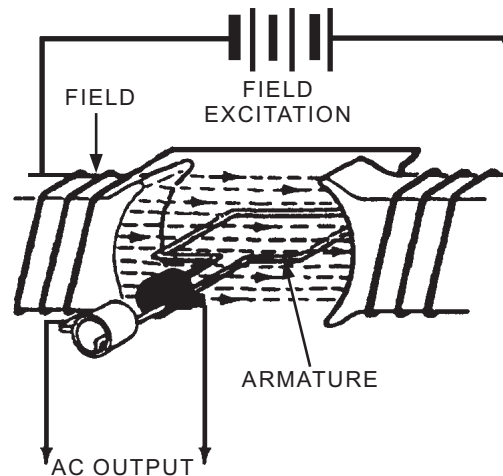

ROTATION ARMATURE AC GENERATOR (ALTERNATOR)

A

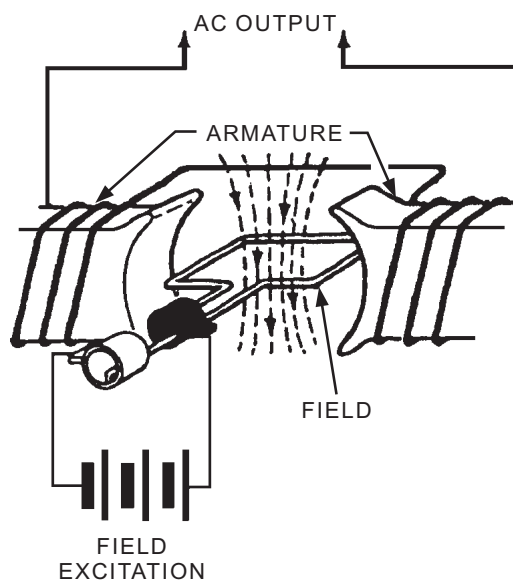

ROTATION FIELD AC GENERATOR (ALTERNATOR)

B

ASf07028

Figure 7-28.—Types of ac generators.

Rotating-Field Generators

The rotating-field generator has a stationary armature winding and a rotating-field winding, as shown in view B of figure 7-28. The advantage of having a stationary armature winding is that the generated voltage can be connected directly to the load. That is, a rotating armature requires slip rings and brushes to conduct the current from the armature to the load. The armature, brushes, and slip rings are difficult to insulate; arc-overs and short circuits can result at high voltages. For this reason, high-voltage generators are usually of the rotating-field type. Since the voltage applied to the rotating field is low-voltage dc, the problem of high-voltage arc-over at the slip rings does not exist.

The stationary armature, or stator, of this type of generator holds the windings that are cut by the rotating magnetic field. The voltage generated in the armature as a result of this cutting action is the ac power that is applied to the load.

The stators of all rotating-field generators are about the same. The stator consists of a laminated iron

core with the armature windings embedded in this core, which is secured to the stator frame.

Rotating field generators are used in power-generating support equipment. The rotating field ac generators used in support equipment are actually two generators mounted on a single shaft. Figure 7-29 shows a pictorial of an ac generator. The only purpose for the dc exciter generator is to supply the direct current required to maintain the ac generator's magnetic field.

Refer to view A of figure 7-30 during the following explanation. The exciter is a dc, shunt-wound, self-excited generator. The exciter shunt field creates an area of intense magnetic flux between its poles. When you rotate the exciter armature in the exciter-field flux, voltage is induced in the exciter armature windings. The output from the exciter commutator is connected through brushes and slip rings to the generator field. Since this is direct current, already converted by the exciter commutator, the current always flows in one direction through the generating field. Thus, a fixed-polarity magnetic field is maintained at all times in the generating field

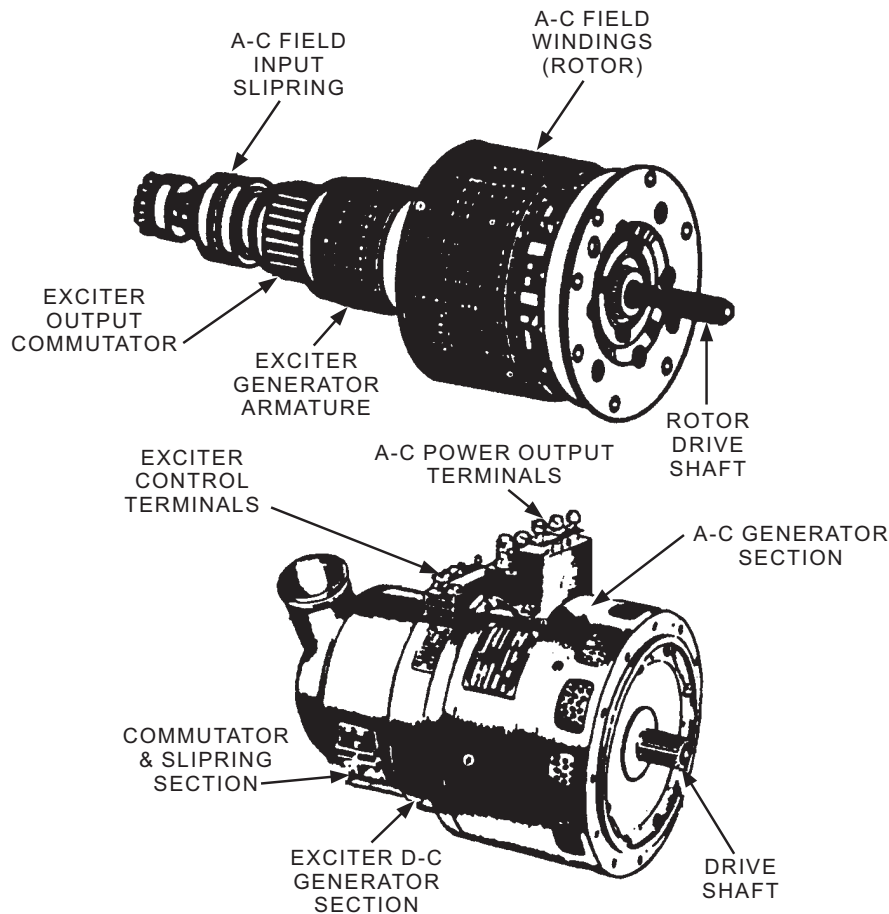

ASf07029

Figure 7-29.—An ac generator pictorial.

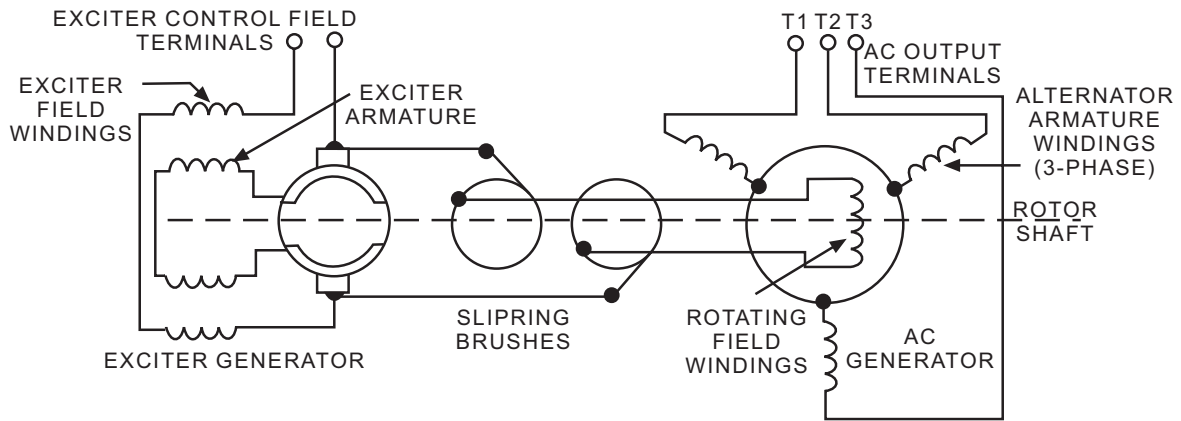

A TYPICAL AC GENERATOR (SCHEMATIC)

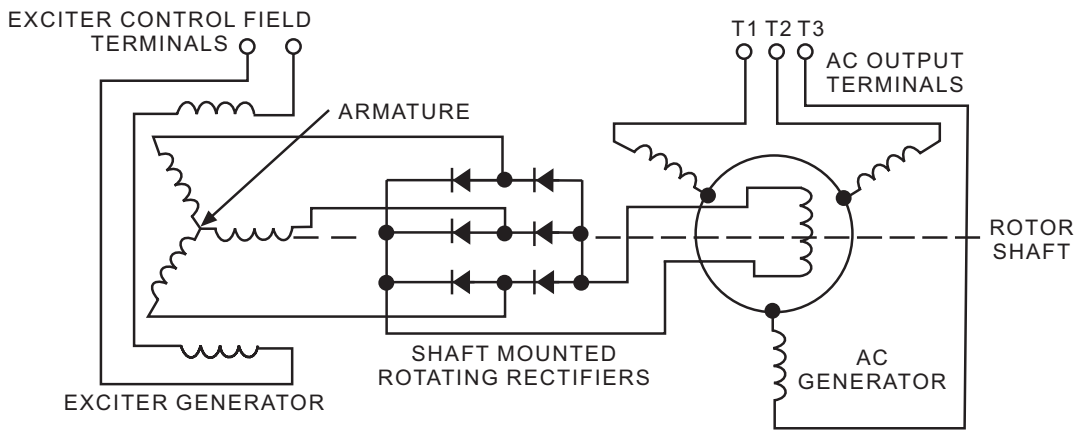

B BRUSHLESS GENERATOR (SCHEMATIC)

ASf07030

Figure 7-30.—Ac generator schematic drawings.

windings. When the generating field is rotated, its magnetic flux is passed through and across the generator armature windings.

The armature illustrated is wound for a three-phase output. Remember, a voltage is induced in a conductor if it is stationary and a magnetic field is passed across the conductor, the same as if the field is stationary and the conductor is moved. The alternating voltage in the ac generator armature windings is connected through fixed terminals to the ac load. View B is a simplified schematic of a brushless generator using diodes instead of brushes and slip rings.

AC VOLTAGE REGULATION.—The amount of voltage induced into the ac generator windings depends mainly on three things—the number of conductors in series per winding, the speed of the generator, and the strength of the magnetic field. Any of these could be used to control the generator output voltage.

The number of windings is fixed, and the demand is for constant frequency; therefore, a constant speed. Thus, the only practical remaining method for voltage control is to control the strength of the rotating magnetic field. In views A and B of figure 7-30, you can see that by varying the exciter armature dc output voltage, the ac generator field strength is also varied.

The ac generator voltage regulation is obtained by controlling the output of the exciter. The exciter output is controlled by varying the current flow through the exciter field windings. Therefore, the essential function of the voltage regulator is to use the ac generator output (which it is designed to control) as a sensing influence to control the amount of current the exciter supplies to its own field. The most widely used ac regulator is the solid-state voltage regulator.

PHASE SEQUENCE CONTROL.—When high-capacity ac power systems became a part of naval aircraft, accompanying problems developed in both the aircraft and the ac system in the form of electrical

fault conditions. Two faults that occur (which support equipment could cause) are voltage and frequency faults. Voltage control was discussed in the preceding paragraphs; however, you need to know more about an ac voltage fault that could be a problem—improper phase sequencing of the MEPP's ac generator output. The normal phase sequence of the MEPP's and aircraft's ac generator is A-B-C; therefore, if the sequence of the MEPP's ac power was B-A-C, it must not be allowed to enter the aircraft's electrical circuitry. Improperly phased voltages applied to the aircraft electrical systems could cause serious damage to the three-phase instruments, motors, and servomechanisms by trying to reverse their rotation. This damage, aside from twisting, breaking, and binding, could result in overheating and fire.

A phase sequencing protector, normally located in the aircraft, contains a phase sequence-sensitive relay

that does not allow external ac power from a MEPP to be applied to the aircraft's electrical system unless it is of the proper phase sequence.

The most common cause of improper phase sequencing of MEPP equipment is incorrect connection of the MEPP's ac power output cable. If the output cable leads are not properly connected at the unit's ac output terminals, the phase sequence will not be A-B-C. Therefore, any time the ac power from a MEPP is rejected by an aircraft, the receptacle end of the power cable should be checked with a phase sequence indicator, especially if the power cable has just been replaced. The AN/USM 128 (fig. 7-31), when used with an adapter or an ac electrical load bank, can test for proper phase sequence at the cable end.

When correcting a problem of improper phase sequence, keep in mind that a generator does not

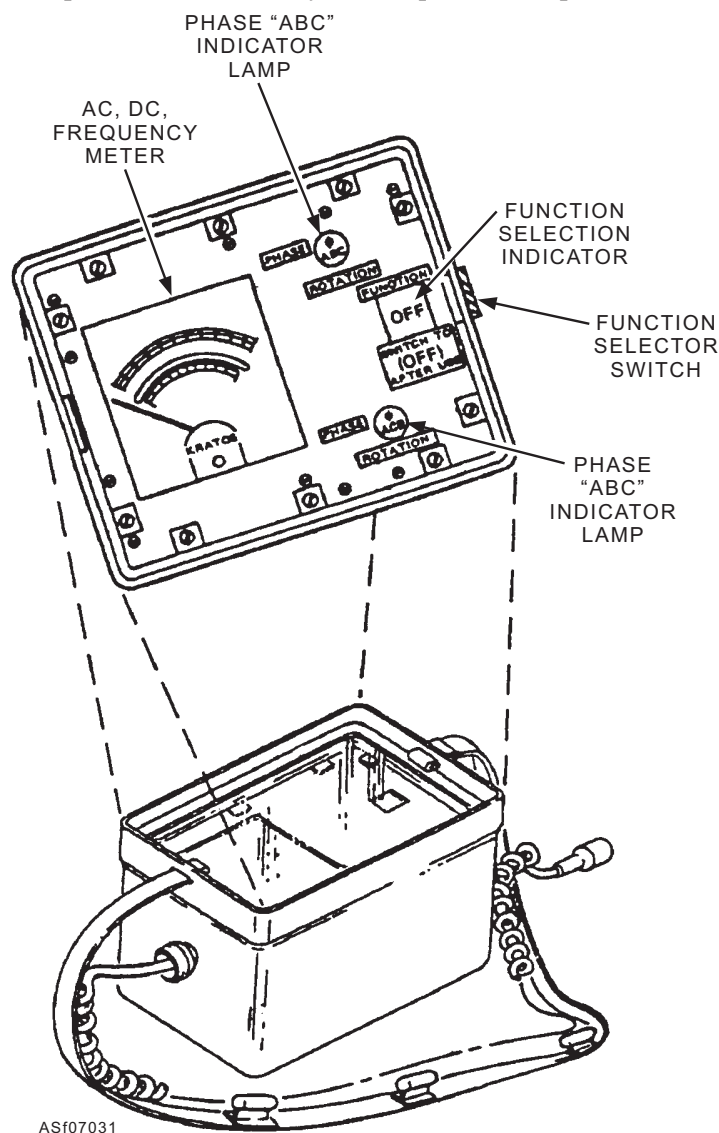

ASf07031

Figure 7-31.—AN/USM-128A electrical test set.

arbitrarily change phasing. The phase sequence gets changed when maintenance is performed on the unit and the cables are not reinstalled on the proper output terminals. Review records to determine how the phasing might have been changed; if the cable was replaced, do not attempt to correct the problem by changing the cables at the generator (or vice versa). Yes, it will remedy the problem for the aircraft power rejection, but it will create further problems later when tracing out wire numbers for other non-related problems.

FREQUENCY CONTROL.—During certain phases of ac generator operation, it is necessary to prevent its output from being connected to the aircraft electrical system. One of the most common times is during a low-frequency output condition; this occurs when the generator has been started but has not reached

full output speed. Another is when the generator has been shut down and/or slows below a safe output frequency. The generator may be connected or disconnected, as needed, through the use of any number of frequency-sensitive devices.

The simplest of frequency-sensitive devices employs a speed switch, which closes when the ac generator's prime mover reaches a safe speed (frequency). This speed switch simply opens or closes the circuit to the main ac power contactor relay. The disadvantage of this speed switch is its sensitivity.

Where frequency protection must be limited to a narrower range of generator speed (frequency), the electrical-type frequency-sensitive device is generally used. The operating principles of a commonly used type of electrical frequency control device are similar to those of the circuits shown in figure 7-32. The

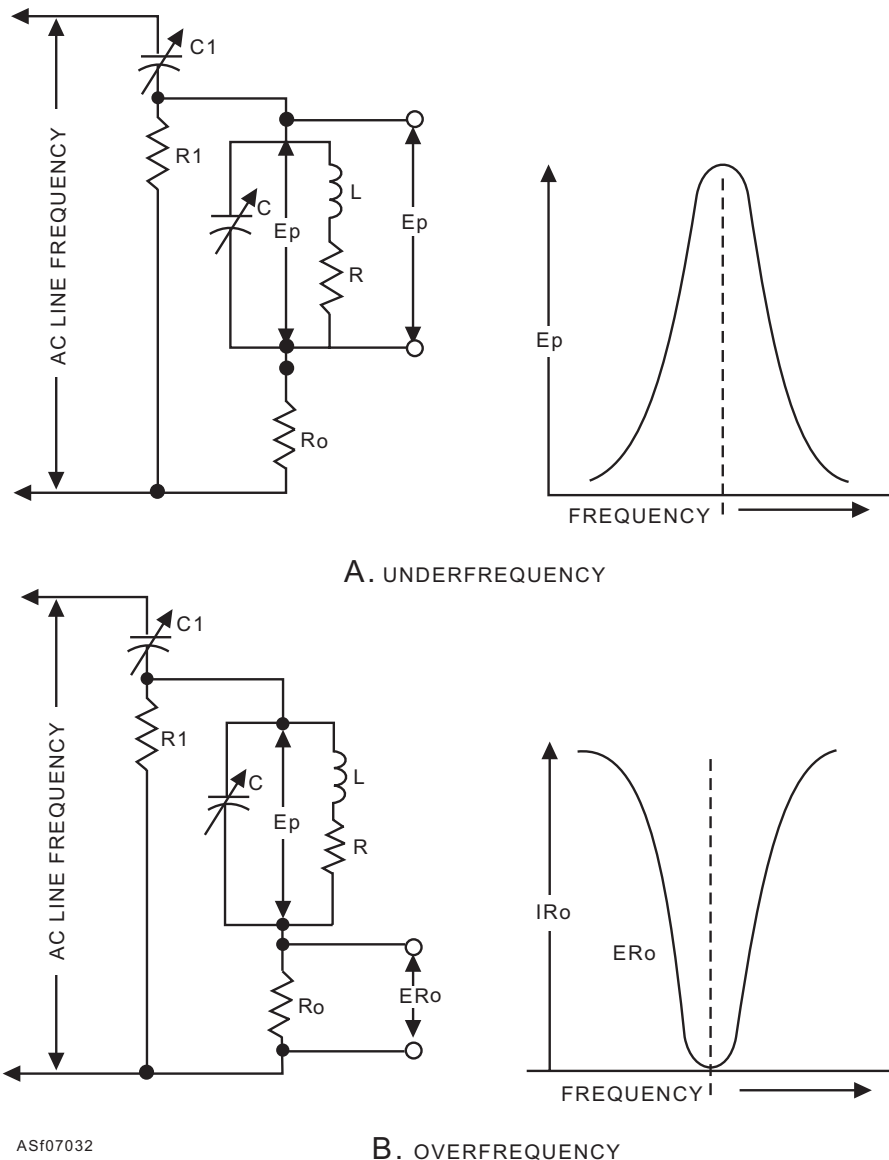

Figure 7-32.—Electrical frequency control circuits.

circuit, illustrated in view A, is for controlling underfrequency, and the circuit in view B is for controlling overfrequency; however, both circuits are very similar in design since they work on varying the frequency from a preset resonant frequency.

In both circuits, line voltage is applied through C1 and R1, so that a specific voltage appears across each when line frequency is correct. Keep in mind that as frequency goes up or down, the capacitive reactance of C1 varies. Therefore, with a frequency change there is more or less voltage drop across C1, and this results in a voltage change across R1.

The voltage of R1 is applied through a parallel tuned L-C-R (inductance-capacitance-resistance) circuit and a resistor (R_o). Because of the characteristics of a resonant parallel circuit, the impedance of the tuned circuit is maximum and line current is minimum. Therefore, the current through R_o is minimum.

Since the impedance of the tuned parallel circuit is maximum at resonance, its voltage drop (E_p) is maximum; the voltage drop (E_{Ro}) across R_o is minimum. With an off-resonance to either side (increased or decreased frequency), the impedance of the tuned circuit decreases, and accordingly, the voltage (E_p) across it decreases. At the same time, the voltage (E_{Ro}) across R_o increases because the current through the line increases. The rise of E_p is shown by the graph in view A.

The circuit shown is used for underfrequency control. The parallel tuned circuit is set for resonance at a frequency of 400 hertz. When the ac generator output frequency is 400 hertz, a specific voltage develops across C1 and R1. The voltage of R1 applies across the resistor R_o and the tuned circuit. At this time the voltage drop across the tuned circuit is maximum and can be used to trigger a silicon-controlled rectifier, bias transistor, or directly control a relay. For purposes of discussion, assume voltage E_p is directly applied to a relay coil, and that at about 400 hertz, E_p is great enough to energize the relay, thereby connecting the ac generator to the load.

When line frequency decreases, more voltage will be dropped across C1 (decrease in frequency causes C1 reactance to increase) so less voltage is dropped across R1; therefore, less voltage is impressed across the tuned circuit and resistor R_o. In addition, the tuned circuit goes off resonance with the change in frequency. Its impedance decreases, and accordingly, the voltage (E_p) decreases (see the graph). As a result,

two effects have combined to reduce the voltage (E_p) to the relay coil with a decrease in frequency. When the decrease of line frequency is great enough, the resultant decrease of voltage (E_p) to the relay causes it to become de-energized. This, in turn, controls the ac generator output circuit by disconnecting it from the load.

In view B of figure 7-32, the same circuit is shown except that the output terminals are across resistor R_o instead of the tuned circuit. This circuit, as illustrated, can be used for overfrequency control. Like the underfrequency circuit, view A, this circuit is resonant at 400 hertz, has a specific voltage developed across C1 and R1, and the voltage of R1 is applied across the tuned circuit and resistor R_o. The graph in figure 7-32 illustrates the decrease of voltage across R_o when the tuned circuit is resonant.

When line frequency increases, less voltage drops across C1, so more voltage drops across R1. Therefore, more voltage impresses across the tuned circuit and resistor R_o. In addition, the tuned circuit goes off resonance; its impedance decreases; its voltage drop decreases; line current increases, and thereby increases the voltage (E_{Ro}) drop across R_o. As a result, two effects combine to increase the voltage (E_{Ro}) to the relay coil with an increase in frequency. When the increase of line frequency is great enough, the resultant increase of voltage (E_{Ro}) causes the relay to energize. This, in turn, opens the MEPP's ac generator output circuit, disconnecting it from the load.

Types of AC Generators

Ac generators range in size from the automotive alternator to the 90,000 volt-ampere machines used on the NC-10C. All ac generators have certain characteristics in common, regardless of size, shape, or rating.

- The ac output is taken from a set of stationary windings (stator).
- The ac generator field (rotor) is a rotating magnetic field with a fixed polarity.
- The output voltage is controlled by varying the strength of the rotating field.
- The output frequency is controlled by the speed of the magnetic field rotation.
- A prime mover is required to turn the rotor.

THREE-PHASE AC GENERATORS.— Current military specifications require that the basic ac

power generating systems for servicing aircraft have outputs of 120 and 208 volts. These voltages are obtained by designing the generator to produce 120 volts per winding and connecting them in a wye system, as shown in view A of figure 7-33. The voltage between the neutral wire and any one phase is 120 volts. The phase-to-phase voltages are 208 volts. When a load is connected phase to phase, two windings are in series across it. The vector sum of the two generated voltages is 1.73 times the voltage of a single phase.

The line-to-line voltage found in a three-phase, wye-connected system is the vector sum of the voltages generated by two separate phase windings. Because a phase difference of 120 degrees exists between the two generated voltages, they reach their peak amplitudes at different times; consequently, they must be added vectorially, not directly. The power is proportional to the product of current and voltage. The higher voltage requires less current for the delivery of an equal amount of power. Increasing voltage instead of current allows the use of smaller current-carrying conductors in the distribution system and the generator. This makes the system lighter in weight, less costly, and more adaptable for supplying power to a wide variety of loads.

WYE, DELTA, AND OPEN-DELTA SYSTEMS.—Most three-phase distribution systems use the wye or delta connection. Compare the two circuits in views A and B of figure 7-33. The wye system has a distinct advantage over the delta system. The wye system has two voltages available. The lower voltage (120 volts) is extracted from the phase-to-neutral connection. The higher voltage (208 volts) is available from the phase-to-phase connection.

In the four-wire, grounded neutral system, the neutral wire is connected to the frame. This constitutes a ground. The three-phase wires are then connected to the three-phase power receptacle. The convenience

outlets are connected phase to neutral. They supply single-phase power for such items as test equipment and soldering irons.

An advantage of a delta-connected system is that if one winding of the power source becomes inoperative, it can be disconnected. The system still operates, but at a reduced capacity. When power is distributed in this manner, it is known as an *open-delta operation*. If one winding in a wye-connected system fails, it is not possible to operate the system.

BRUSHLESS AC GENERATORS.—The theory of the brushless generator is not new. But, the lack of a small rectifier that could withstand the electric current and rotational stresses produced in the generation of ac caused a delay between the drawing board and the production of a brushless generator. However, with the development of a silicon diode that is small, rugged, and has sufficient current capabilities, the development of a practical brushless generator was possible. The use of brushless generators in MEPPs now greatly increases the time between scheduled maintenance.

Brushless Generator Theory.—A brushless generator is shown in schematic form in figure 7-34. It consists of three main sections: the permanent magnet generator (PMG), the exciter-and-rectifier assembly, and the main ac generator. Each of these sections has rotating and stationary parts. The only connections between the rotating and stationary parts are working air gaps in each of the three sections (no brushes).

The speed of operation of the brushless generator is limited to a narrow range (plus or minus 5 percent). The newer electrical ac generators are driven by constant-speed drive units or constant-speed engines. In most of the newer MEPPs, the generator's operating speed is held to within 1 or 2 percent of the generator's nominal speed. Brushless generators are driven at a speed to produce a 400-Hz output.

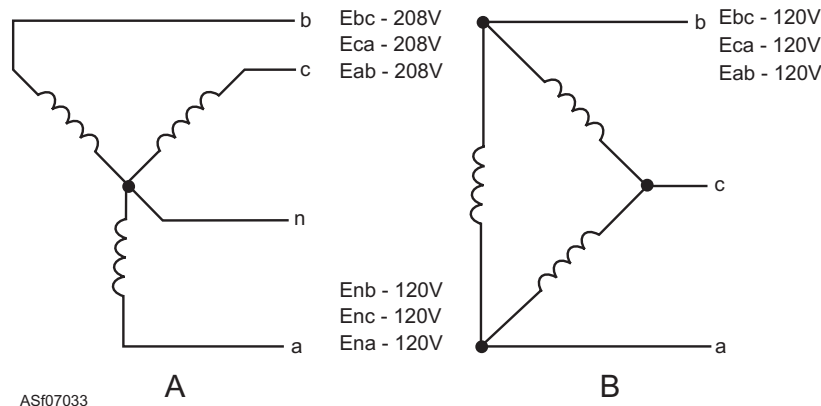

Figure 7-33.—Wye-delta voltage relationships.

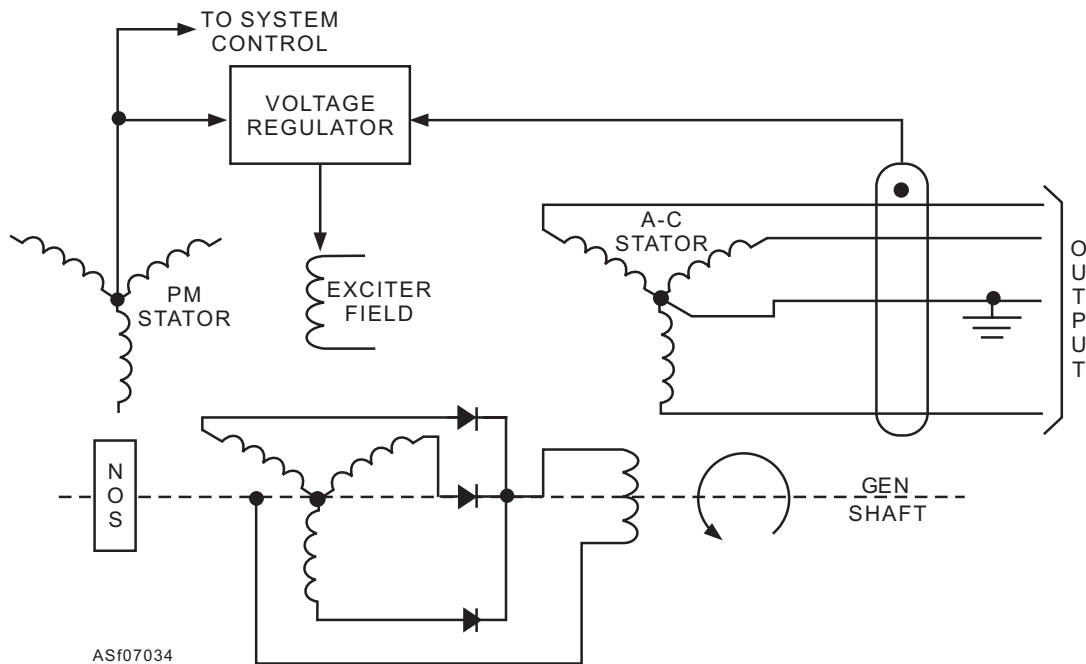

Figure 7-34.—Diagram of a brushless ac generator excitation system.

Permanent Magnet Generator.—The permanent magnet generator (PMG) section consists of a permanent magnet rotor and a three-phase or single-phase stator, depending on the particular model. The PMG is a simple, highly reliable source of power. The power generated by the PMG is used for excitation, for operation of the electrical power control relays, and for operation of the electrical protective system. Since the PMG operates at a constant speed, its output voltage is constant and completely independent of the main generator's output. The PMG continues to deliver power during a failure of the main generator. This arrangement provides positive control of the main generator. The PMG ensures that a source of power is available for buildup of the exciter and main generator. Excitation is not dependent on a residual flux being present in the generator or exciter. The PMG excitation system is designed to operate transistors at their optimum voltage. This prevents exposure of the transistors to the harmful transient voltages present during fault or load-switching conditions of the main generator system.

The PMG section of a brushless generator is a simple, reliable source of power. The PMG makes the brushless generator a completely self-contained unit that does not depend on an external source of power for buildup or excitation during operation.

AC Voltage Regulators

The essential function of the voltage regulator is to use the ac output voltage as a sensing influence to

control the amount of current the exciter may supply to its control field. A decrease in the output ac voltage causes an increase in the exciter control field current. An increase in the output ac voltage causes a decrease in the exciter control field current. The speed of the generator must be maintained to provide 400 Hz. All types of regulators perform the same functions, but accomplish them through different operating principles.

The ac voltage regulator is usually a complicated design. The schematic shown in figure 7-35 is a simplified basic circuit. It is used as a matter of simplicity in explaining the principles of ac voltage regulating.

The voltage regulator is a static unit that samples one phase of the generator output. It is compared to a reference voltage and biases an output amplifier with the differential signal. Varying the gain of the output amplifier varies the dc current passing through the windings of the exciter. The exciter applies a varying current to the generator field coils. This simultaneous action varies the generator voltage output.

One phase of voltage is taken from the generator and applied across the primary side of transformer T1 and resistor R1. The secondary output of T1 is applied to full-wave rectifiers, CR1 and CR2. The ripple component of the output is reduced by the LC filter network consisting of L1 and C4. The output of T1 is dropped by R2 and Zener diode VR2. This provides a reference voltage for R14 and the base of Q3. The output of T1 is also applied to the voltage divider

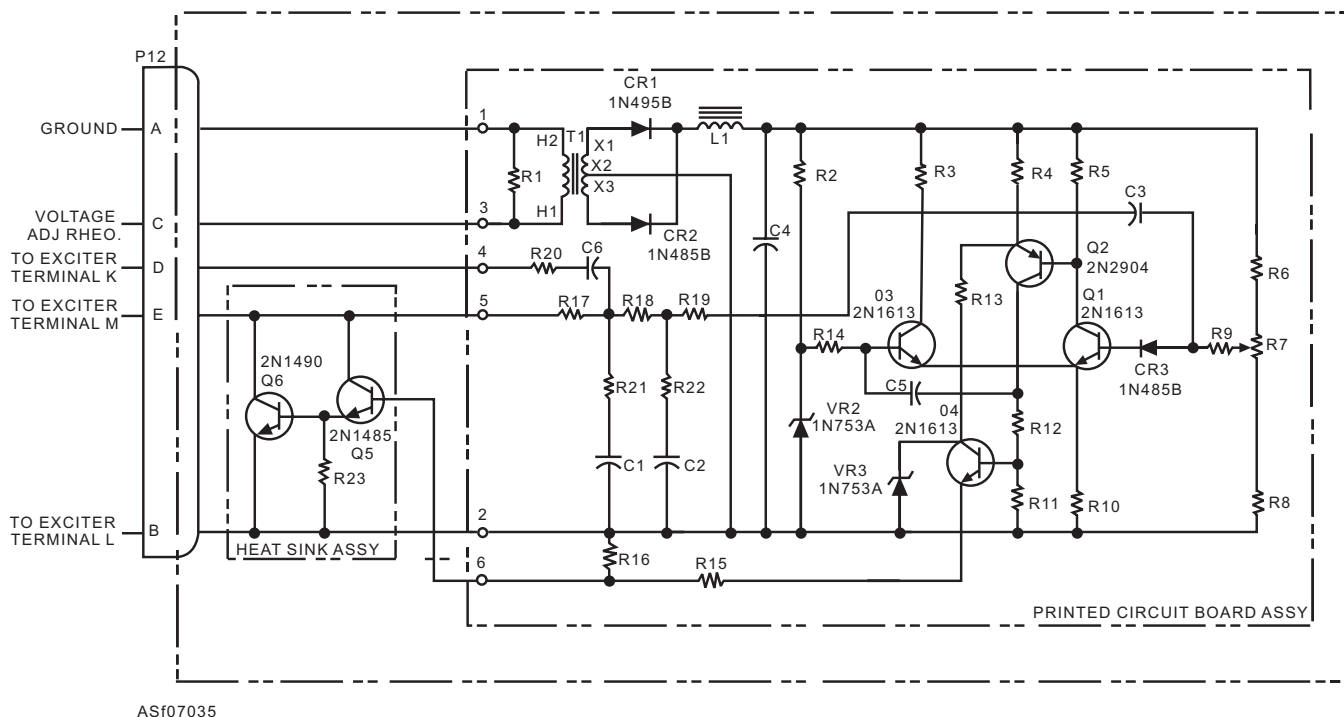

Figure 7-35.—An ac voltage regulator (VR2) simplified schematic.

circuits R6, R7, and R8. The voltage tapped at R7, a variable resistor, is applied to the base of Q1 through R9 and CR3. Transistors Q1 and Q3 are arranged in a differential amplifier circuit. This arrangement amplifies the difference between the reference voltage and the voltage signal of the generator output. The output of Q1 is an error signal. It biases the base of Q2 for further amplification. The collector output of transistor Q2 drives the base of the emitter follower stage Q4. The emitter follower stage Q4 drives the Darlington amplifier Q5 and Q6.

The Darlington stage Q5 and Q6 controls the amount of dc current that flows to the exciter fields. If the generator's output voltage rises above the desired value, the differential amplifier amplifies the increased difference between the dc circuit voltage and the reference voltage. The series of amplifiers are then driven by transistor Q1. All amplifiers respond with a high output current. This causes the Darlington amplifier to produce a higher current output to the exciter. This increases the field strength of the exciter, resulting in a lower generator field excitation. This causes a reduced generator output. When the generator output falls below the desired level, the preceding sequence reverses, producing more field excitation.

A change in load conditions can result in transient voltage changes that could cause the generator voltage to oscillate around its nominal value. To prevent such instability, a rate-controlled feedback circuit is used.

The circuit consists of resistors R17 through R22 and capacitors C1, C2, and C6. Combined, they develop a single voltage to the base of transistor Q1. This causes the differential amplifier to react faster to transient voltage changes. Diode CR3, in series with the base of Q1, improves the temperature stability of the circuit. Capacitor C5 reduces ripple voltages and prevents high-frequency oscillation. Zener diode VR3 prevents the varying collector current of Q4 from causing a varying load on the voltage sensing circuitry.

AC Circuit Protection

High capacity power generating equipment must have a system for sensing fault conditions in voltage and frequency. The sensors used to detect fault conditions are located in a PROTECTIVE PACKAGE. The sensors in the circuits sense overvoltage, undervoltage, overfrequency, underfrequency, and phase sequence. When one or more of these conditions occur, control relays are energized to cut off the output voltage supply. The operating limits for ac voltage are 105 to 125 volts. The phase sequence must be in proper order, A-B-C.

Mobile electric power plants (MEPPs) that are driven by electric motors usually do not have dc generators. As in the case of the MMG-1A, the three-phase ac input voltage is stepped down by a transformer and rectified to dc. Figure 7-36 shows a simplified schematic of a similar circuit.

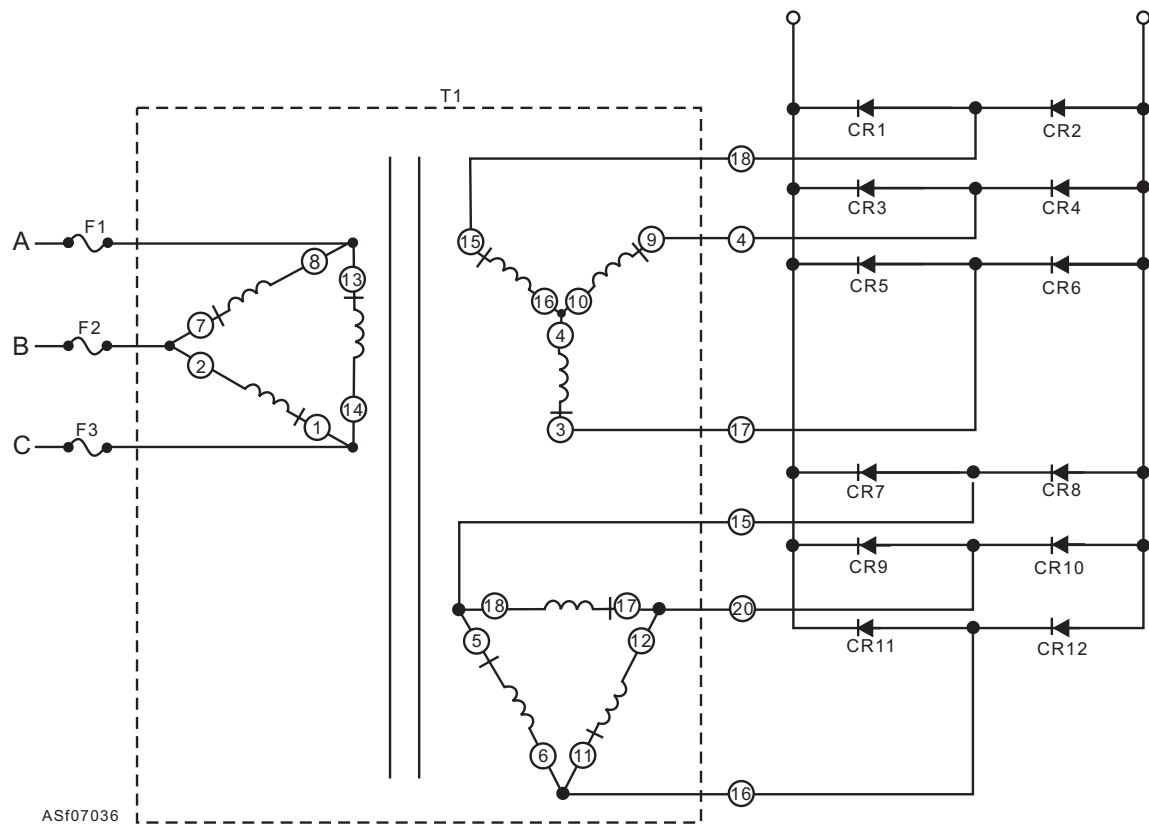

Figure 7-36.—A dc power supply circuit.

The three phases of the input voltage are applied to the primary winding of transformer T1. The input voltage is stepped down by mutual induction. The adjustable output of the secondary winding is 22 to 39 Vac. The output is controlled by a dc voltage regulator and a magnetic amplifier. The six-phase output must be rectified to dc. This is done by the full-wave rectifier network of CR1 through CR12. Each phase has a full-wave rectifier.

The maximum output of the rectifier circuit can be as high as 750 amperes. A detailed description of the circuit operation is found in the intermediate maintenance section of the applicable manufacturer's manual.

CURRENT RANGE

The generators on MEPPs are designed for a wide range of current applications. Large units, such as the NC-2A and NC-8A, use dc generators rated as high as 500 amperes continuous duty. They may supply as much as 750 amperes intermittently. Consult the applicable technical manual for the maximum current range. Exercise caution when you operate a generator at a high current level. Specific procedures are established by the manufacturer. Usually, the use of 750 amperes must not exceed 20 seconds ON and 40

seconds OFF. If this is practiced for 30 minutes, operate the unit for 30 minutes at no load to allow the generator to cool.

The operating speed of a generator must be maintained to produce the rated voltage and current output. The required operating speeds vary widely. The speed range of the NC-2A is 6,000 rpm; the NC-8A is 2,400 rpm. The high-speed generator can produce more power than a low-speed generator of the same size. This is possible because less wire in series is required to produce a given voltage in the high-speed generator. Since a shorter wire is required, you can use a larger wire. This greatly improves the current-producing capability of a generator.

The large amounts of current delivered create a heat problem. Most MEPP generators are cooled by internal fans (fig. 7-37). You must be sure the airflow is not restricted and the generator is not overheating. The amount of heat that can be removed by air is determined by the volume and density of the air. The warmer the air becomes, the less dense it becomes and the less heat it can remove. If the temperature of a generator is allowed to rise too high, the insulation may be damaged. The nameplate attached to a generator identifies the voltage, current rating, speed range, and temperature rise. If the plate cannot be found, refer to the manufacturer's manual.

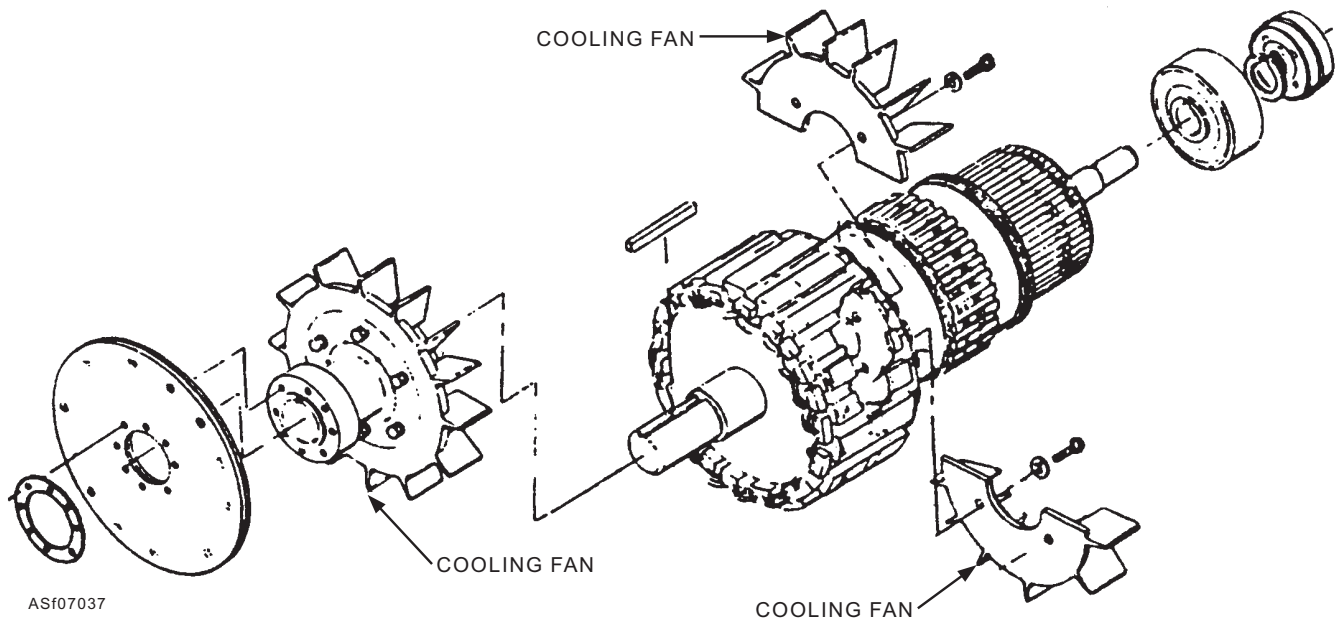

Figure 7-37.—Internal cooling fans of a typical generator.

POWER AND POWER FACTOR

In a dc circuit, power is computed by the equation $P = EI$ (watts equal volts times amperes). If 1 ampere flows in a circuit at a pressure of 208 volts, the power is 208 watts. The product of the volts and the amperes is the **TRUE POWER** in the circuit.

In an ac circuit, a voltmeter indicates the effective voltage, and an ammeter indicates the effective current. The product of these two readings is called the **APPARENT POWER**. Only when the ac circuit is made up of pure resistance is the apparent power equal to the true power. When the impedance of the circuit is either inductive or capacitive, the current and voltage are not exactly in phase. The true power is less than the apparent power. The true power may be obtained by a wattmeter reading. The ratio of the true power to the apparent power is called the **POWER FACTOR**, and is equal to true power divided by apparent power.

It is desirable that equipments using ac power have as near a unity power factor load as practicable. This improves the efficiency of power distribution by reducing the line current and I^2R losses. Most ac loads are somewhat inductive, resulting in a lagging power factor. You may obtain power factor correction by connecting a capacitor of the proper value in parallel with the circuit. The connection should be made as close to the inductance load as possible.

The nonenergy component of the current in the inductive branch is 180 degrees out of phase with the capacitive current. These currents circulate between the capacitor and inductive load and do not enter the

line. The vector sum of capacitor current and total inductive load current is equal to line current. The line current is now in phase with the applied voltage to the parallel combination of the inductive load and capacitor. This reduction in line current reduces line loss and increases the efficiency of transmission.

Information on power factor and power factor correction may be found in NEETS, Module 8, *Introduction to Amplifiers*.

GROUNDED SYSTEMS

Almost all of the electrical and electronic circuits you work with are grounded. This means that one leg of the circuit is connected to a common conductor, such as a structural member (frame) of the power plant. When the grounded leg of the circuit is connected to a good electrical conductor, this conductor may serve as one leg of the circuit. No separate conductor is needed for this leg of the circuit.

Figure 7-38 shows a simple grounded system. Even though the grounds are shown at different points, the potentials at these points are essentially the same since they are connected to a common conductor.

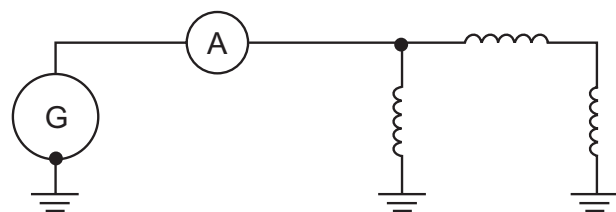

Figure 7-38.—Grounded system.

The three-phase ac generator is most commonly connected in what is called a *FOUR-WIRE WYE*. In this system the common connection for the phases, called *NEUTRAL*, is connected to ground. There is also a *THREE-WIRE WYE*, accomplished by connecting one of the phases to ground, usually the B phase. If this system is used, care must be taken to ensure that all three-phase equipment have the same phase grounded. Another method of connecting the phases is called *DELTA*. In this system, a common connection of two of the phases is grounded. Figure 7-33 shows the grounding of the three-phase systems.

In the dc systems, the negative (-) side of the circuit is usually connected to ground (determined by the way the power supply is connected).

Any wire that completes the circuit to the ground network for an equipment is designated with the letter N. Any wire so designated may come in contact with ground at any point without causing malfunction of the equipment.

A grounded circuit has advantages since it reduces overall weight by using fewer conductors. This results in a reduction in cost and space requirements. Other advantages are that troubleshooting is simplified to some extent and the impedance of the ground return path is lower than that of a wire conductor. The grounded system also has disadvantages. Short circuits result when a bare spot on any ungrounded conductor touches ground.

UNGROUNDING SYSTEMS

The term *ungrounded system* means that the circuit is in no way connected to ground. All conductors are run from the power source to the loads. Circuits of this type are often referred to as being above ground. The ungrounded system has a number of advantages. It prevents one circuit from feeding into another. No malfunction of equipment occurs should one conductor become accidentally grounded. The circuits are completely insulated from each other. The system has the disadvantage of adding more weight because it requires more conductors than the grounded system. This results in added cost and space requirements.

Q7-8. Which of the following is NOT a method of increasing the output of a generator?

1. Increase the strength of the magnetic field
2. Increase the speed of the conductor
3. Increase the number of brushes
4. Increase the length of the conductor

Q7-9. All generators, regardless of the size or whether they are ac or dc, work on the principle of magnetic induction?

1. True
2. False

Q7-10. What is the one major difference between an ac generator and a dc generator?

1. The ac generator has brushes and the dc generator does not
2. The ac generator has several brushes and the dc generator has only one brush
3. The ac generator has slip rings and the dc generator has a commutator
4. The ac generator has a rotating field and the dc generator has a stationary field

Q7-11. A generator that supplies its own field excitation is referred to as what type of generator?

1. An ac generator
2. A dc generator
3. A self-contained generator
4. A self-excited generator

Q7-12. Which of the following parts of the generator does the regulator control to control the generator output?

1. The armature voltage
2. The field excitation
3. The stator voltage
4. The winding voltage

Q7-13. The two types of ac generators are rotating-field and rotating-armature?

1. True
2. False

Q7-14. The ac generator voltage regulation is obtained by controlling the output of which of the following components?

1. The exciter
2. The regulator
3. The stator
4. The rotor

Q7-15. What is the ac phase-to-phase voltage of a support equipment power generator?

1. 115 Vac
2. 120 Vac
3. 208 Vac
4. 220 Vac

Q7-16. Which of the following is NOT a voltage protection function of a mobile electric power plant?

1. AC overvoltage
2. DC undervoltage
3. Underfrequency
4. Phase sequence

MOBILE ELECTRIC POWER PLANTS (MEPP)

LEARNING OBJECTIVE: Identify the components of mobile electrical power plants (MEPP).

A mobile electric power plant (MEPP) is a power generating unit. Some models can be driven under their own power; others must be towed. An operator's license is required to drive a MEPP and to operate the generators.

There are many types of MEPPs available. Some are designed for universal use, while others can be used only on specific aircraft.

NC-2A MOBILE ELECTRIC POWER PLANT

The NC-2A (fig. 7-39) is a self-propelled, diesel engine-powered service unit. It is front-axle driven, steered by the two rear wheels, and readily maneuverable in congested areas. The front axle is driven by a 28-volt dc, reversible, variable-speed motor that is capable of propelling the unit up to 14 mph on level terrain. The unit has a turning radius of approximately 11 feet.

The primary source of power is a three-cylinder, water-cooled diesel engine, which drives the ac and dc generators through a speed-increasing transmission. All propulsion and electrical power controls are available to the operator on three panels located in the front and to the right of the operator's seat.

The power plant is designed for air transport; it is provided with two tie-down rings each on the front and the rear bumpers. Forklift channels are located between the front and rear axles, providing safe lifting points for the unit.

The ac generator is an aircraft-type, single-bearing, synchronous, 115/200 volt, 400-hertz, three-phase, four-wire wye, brushless generator with an output of 30-kVA at 6,000 rpm.

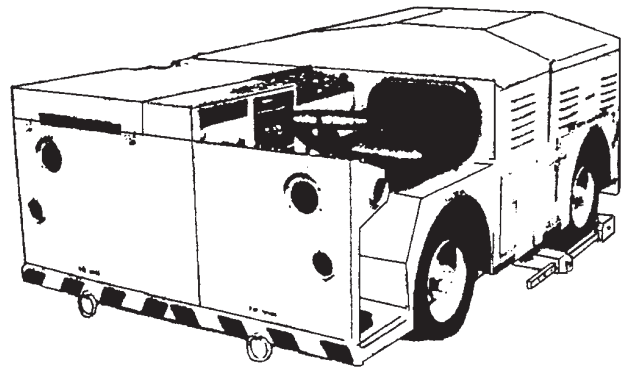

A

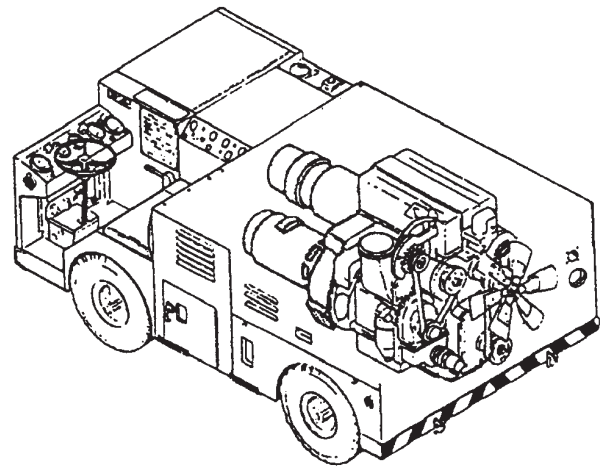

B

ASf07039

Figure 7-39.—NC-2A mobile electric power plant.

The dc generator is an aircraft generator with an output of 28 volts and up to 500 amperes at a maximum speed of 6,300 rpm. Table 7-3 lists the leading particulars for the NC-2A.

Governors

When an electrical load is placed on a generator, the prime mover speed decreases. When the load is removed, the prime mover speed increases. In a dc generating system, the prime mover has to drive the generator within a certain speed range (depending on the particular generator) to maintain the required voltage, even though the system has a voltage regulator. In an ac generating system, speed is far more critical because it also determines the output frequency. Unless some means is used to regulate the speed, engines will over speed. A manual throttle is

Table 7-3.—Leading Particulars for the NC-2A

1. GENERAL	
Nomenclature.	Mobile Electric Power Plant
Type designation.	NC-2A
Manufacture.	Consolidated Diesel Electric Company
Maximum self-propelled speed.	14 mph
Turning radius.	130 inches
Ground clearance.	7 inches
2. DIESEL ENGINE	
Manufacturer	Detroit Diesel Engine Division of General Motors Corporation
Series.53 diesel
Model.5033-7201
Number of cylinders.	3
Cooling.	Water-cooled
Governed Speed.	2550 rpm (approximately)
Bore.	3.875 inch
Stroke.	4.5 inch
Displacement	159.3 cubic inches
3. DRIVE MOTOR	
Manufacturer.	H. K. Porter Company, Inc.
Model.	E-1127
Voltage.28 Vdc
Speed.950 rpm
Horsepower rating.1.8 hp
4. AC GENERATOR	
Manufacturer.	DC Motor and Generator Division of General Electric Company
Model.	2CM353F1
Capacity.30 KVA
Output.115/200 Vac, 3-phase, 4-wire
Power factor.0.8
Frequency.	400 Hz
5. DC GENERATOR	
Manufacturer.	DC Motor and Generator Division of General Electric Company
Model.2CM247A2
Voltage.28 Vdc
Amperage.	500 A
Minimum speed.5,700 rpm
Maximum speed.6,300 rpm

ineffective because of the varying electrical loads. For these reasons all MEPPs use some type of automatic governor. The NC-2A power plant uses two electronic governors—the drive control module assembly and the engine governor assembly.

Control of the engine speed is accomplished by an electric torque motor that adjusts the fuel flow to the engine. The movement of the torque motor shaft is controlled by the selected governor assembly. The operation of the NC-2A is selected by positioning the mode selector switch. With the mode selector switch in the START/DRIVE position, the drive module assembly controls the torque motor and the speed of the dc generator.

The engine governor assembly takes control of the torque motor when the mode selector switch is turned to the output power position. The engine governor monitors the output frequency of the ac generator, maintaining it at 400 hertz, plus or minus 10 hertz.

System Operation

The NC-2A system is broken down into four major interrelated circuits for ease of explanation. Those circuits are:

- The engine starting circuit
- The vehicle propulsion circuit
- The dc power control and distribution circuit
- The ac power control and distribution circuit

ENGINE STARTING CIRCUIT.—Figure 7-40 is a simplified schematic of the NC-2A starting circuit, and figure 7-41 is a picture of the NC-2A control panel.

Prior to starting the engine, MASTER SWITCH CB4 (fig. 7-40) must be closed, start cutout relay K21 must be energized (closing contacts B1 and B2), and START/DRIVE-SERVICE POWER switch S29 must be in the START/DRIVE position.

Holding ENGINE START switch S14 in the start position energizes auxiliary start relay K20. Start solenoid L1 is now energized through the closed contacts of relay K20 and in turn cranking motor B3 is energized through the closed contacts of solenoid L1. Fuel shutoff solenoid L3 is also energized permitting free flow of fuel to the engine and is held energized during unit operation through water temperature switch S11 and engine oil pressure switch S15.

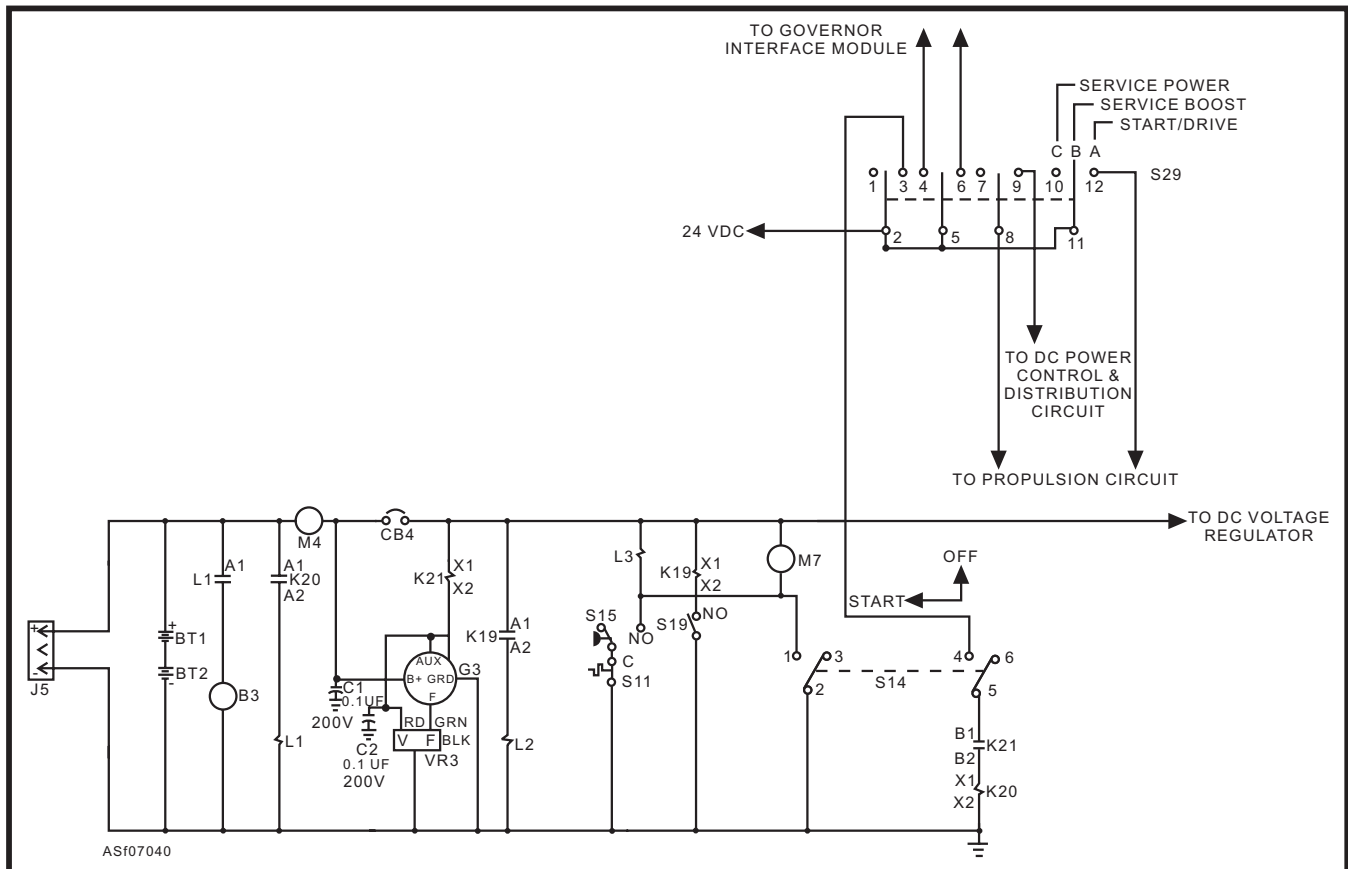
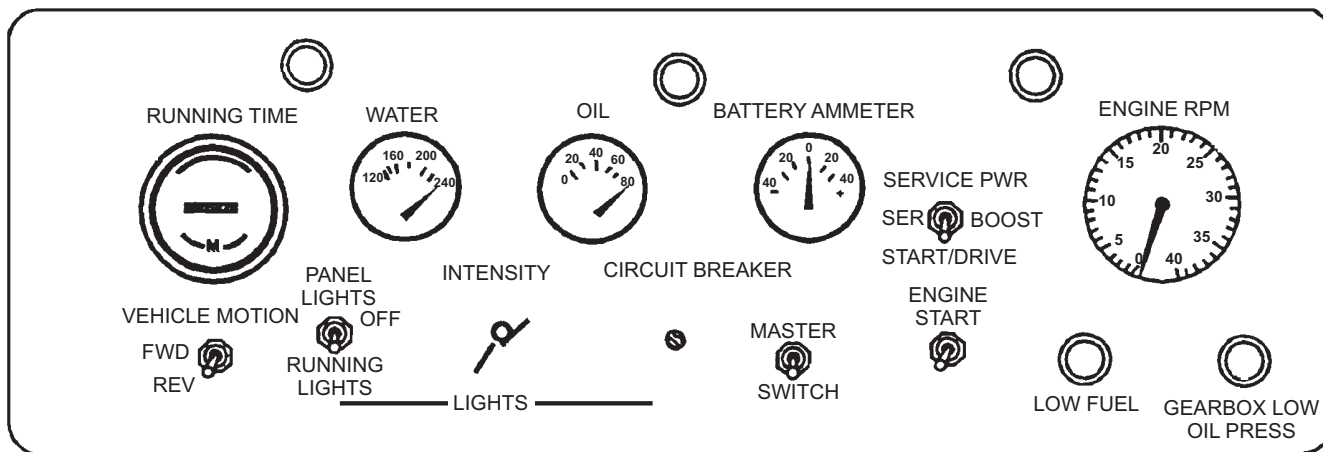

Figure 7-40.—Engine starting circuit.



ASFO7041

Figure 7-41.—Engine control panel.

After the engine fires, releasing ENGINE START switch S14 de-energizes relay K20, solenoid L1 and starting motor B3. Start cutout relay K21 is de-energized by voltage regulator VR3 when the engine reaches approximately 500 rpm. With the engine operating, control of the engine rpm is maintained by the governor.

Should an over speed condition occur (approximately 2,800 rpm) during starting or unit operation over speed switch S19 will close and energize air lockout relay K19. Air shutoff solenoid L2 is now energized through the closed contacts A1 and A2 of relay K19. After an over speed shutdown air shutoff solenoid L2 must be manually reset before engine restart can be accomplished.

Should a high engine temperature condition occur (approximately 200°F), switch S11 will actuate and remove electrical power from fuel solenoid L3 causing the engine to shut down.

Should a low oil pressure condition occur (approximately 10 psi), engine oil pressure switch S15 will actuate and remove electrical power from fuel solenoid L3 causing engine to shut down.

VEHICLE PROPULSION CIRCUIT.—For the discussion of the vehicle propulsion circuit, refer to figure 7-42, a simplified schematic of the propulsion circuit.

Prior to vehicle propulsion, the engine must be operating, the dc power must be on, and the START/DRIVE-SERVICE POWER switch S29 must be in the START/DRIVE position.

For forward operation drive motor lockout relay K17 and forward control relays K13 and K14 must be energized. This is accomplished by placing VEHICLE

MOTION switch S9 in the FWD position and depressing brake switch S7. Drive motor lockout relay K17 is now energized by battery voltage through limit switch S4, brake switch S7, and blocking diode CR5. Relay K17 is held energized during forward operation by battery voltage through START/DRIVE-SERVICE POWER switch S29, and its own closed contacts B1 and B2. Relays K13 and K14 are now energized by battery voltage through switch S29, closed contacts K17, C1, and C2, and K18, A2 and A3, closing their contacts A1 and A2 across the drive motor.

For reverse operation the VEHICLE MOTION switch S9 is placed in the REV position and brake switch S7 is again depressed permitting reverse control auxiliary relay K18 and reverse control relays K15 and K16 to be energized. Contacts A1 and A2 of relays K15 and K16 are closed directing dc generator output voltage through drive motor B1 in the reverse direction. Relay K18 is held energized during reverse operation by its own closed contacts B1 and B2.

Figure 7-43 is a simplified schematic of the engine governor and dc power control circuit, and figure 7-44 is a picture of the dc control panel.

Control of the MEPP speed during propulsion is the same for forward or reverse operation. Safety switch S27 (fig. 7-42) must be held closed and the accelerator pedal depressed for motion. With the dc voltage regulator VR2 (fig. 7-43) isolated from the propulsion circuit, a control or biasing voltage must be induced across the field of the dc generator to permit generator output. This is accomplished by depressing the accelerator pedal and closing limit switch S4 (fig. 7-42). Battery voltage, reduced by speed regulating resistor R1 (fig. 7-42) is induced across the dc generator field through switch S29 (fig. 7-43).

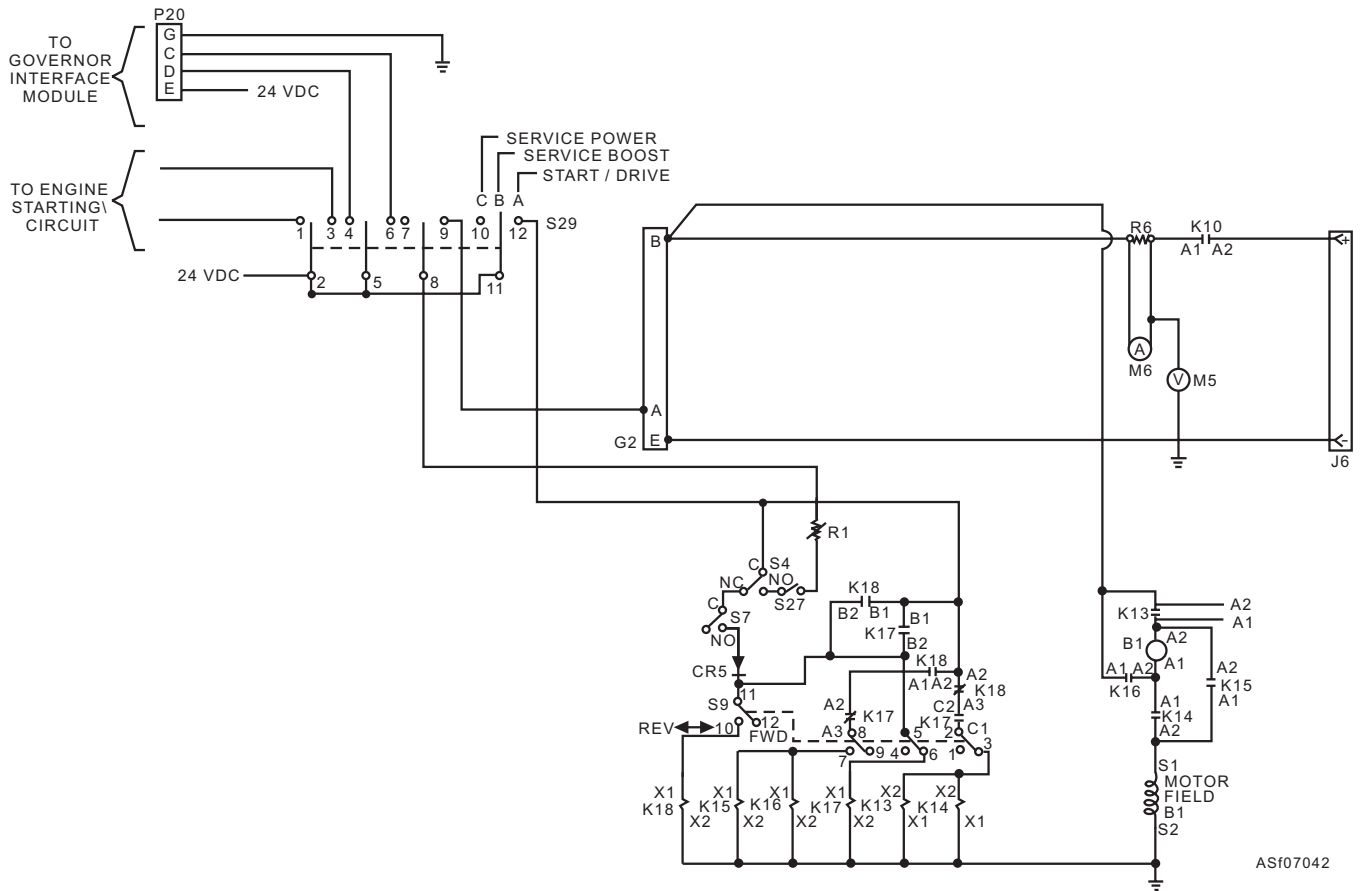

Figure 7-42.—Vehicle propulsion system.

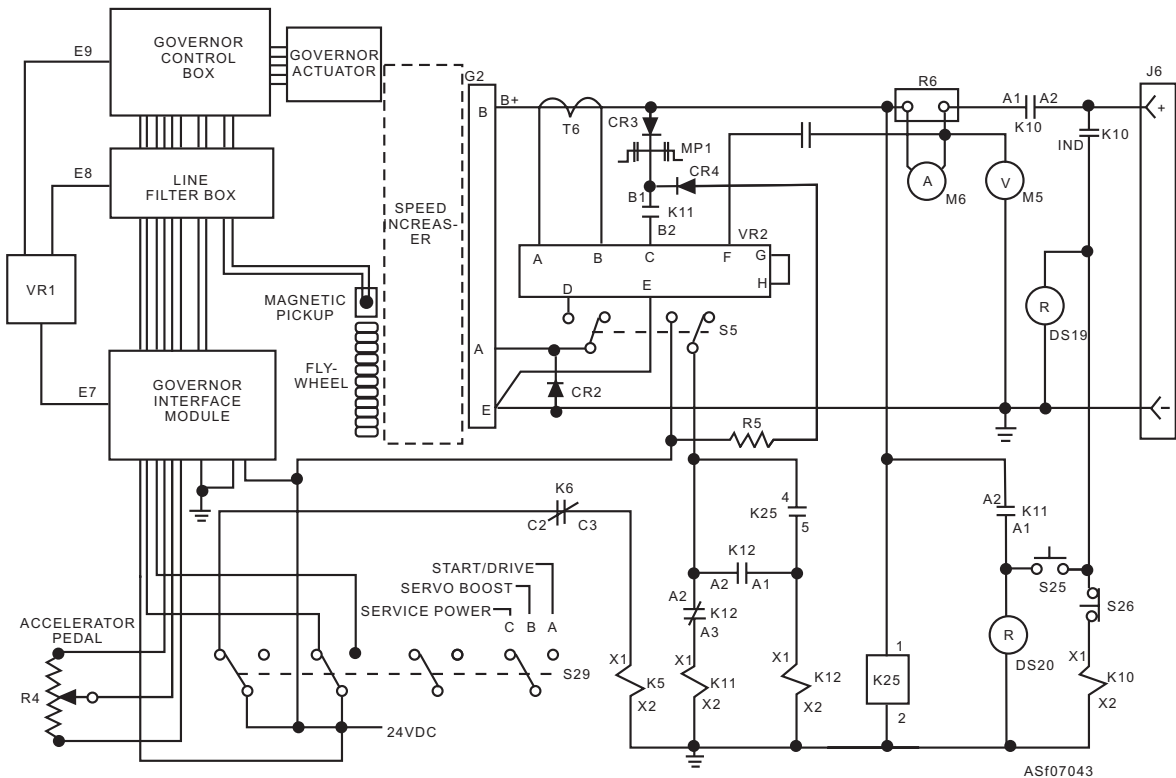
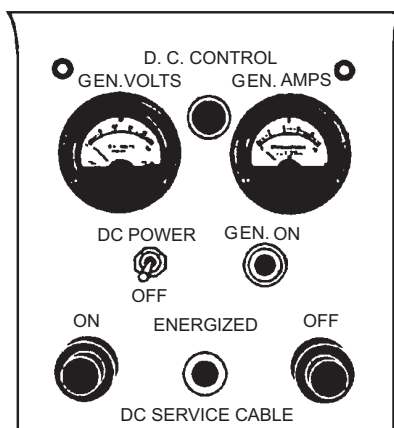

Figure 7-43.—Engine governor and dc power control.



ASF07044

Figure 7-44.—Dc control panel.

The remainder of the discussion of vehicle propulsion refers exclusively to figures 7-43 and 7-44.

The dc generator output voltage, which energizes the drive motor, is now controlled by engine speed using accelerator rheostat R4, governor interface control module E7, line filter E8, and governor control box/actuator E9. The higher the output voltage, the faster the power plant moves. Accelerator rheostat R4 and switch S29 are connected to governor interface module E7. The governor interface module routes the signals from R4 and S29 through line filter E8 to governor control box/actuator E9.

The governor control box/actuator houses a proportional-integral-differential (PID) control circuit which is used to control the actuator output. The governor control box/actuator receives signals filtered by line filter E8 from accelerator rheostat R4, the magnetic pickup mounted on the flywheel housing, and interface module reference speed pot R4. These signals are processed and compared, resulting in an error signal, which is amplified through a gain circuit; the output of the gain circuit is sent to the actuator shaft through the PID control circuit. This causes the actuator shaft to rotate—the actuator converts the electrical signal received from the control box to an angular mechanical output, which is translated along the control rod to the engine fuel control rack. This adjusts engine speed by controlling the amount of fuel injected into the engine.

The actuator returns a feedback signal to the control box, which compares the current output to the input from the magnetic pickup and the reference speed setting. Once accelerator rheostat R4 changes value (i.e., the accelerator pedal is pressed), the magnetic pickup senses the change in flywheel rotation, and the output of the actuator is adjusted by

the PID circuit to change engine fuel flow to correspond to increased or decreased acceleration.

DC POWER CONTROL AND DISTRIBUTION.—The dc generator is an aircraft generator with an output of 28 volts dc and 500 amperes at a minimum speed of 5,700 rpm and a maximum speed of 6,300 rpm. The dc generator is located on the right side of the speed increaser gearbox next to the ac generator. The dc generator supplies the voltage necessary to excite the drive motor, which propels the power plant as well as the voltage required for aircraft servicing.

The transistorized dc voltage regulator, with current limit and line drop compensation, regulates the voltage of the 28-volt, 500-ampere dc generator by statically switching the full generator output voltage back to its own field often enough and for long enough periods of time to maintain required excitation current. The inductive effect of the generator field causes the excitation current to remain virtually constant through any given cycle, even during the time when no voltage is applied.

Prior to dc power distribution, the engine must be operating, the START/DRIVE-SERVICE POWER switch S29 (fig. 7-43) must be in the SERVICE POWER position, and the DC POWER switch S5 must be in the dc POWER position. The following is a step-by-step explanation of how the dc distribution circuit works.

The coil of the power control relay (within the governor interface module) and the coil for the ac generator control relay K5 are energized by battery voltage when S-29 is placed in the SERVICE POWER position. The electronic governor is receiving engine rpm feedback from the magnetic pickup at the flywheel, and holding the diesel engine at approximately 2,550 rpm. This prime mover rpm equates to 6,000 generator rpm (400 hertz). The field of the ac generator is connected to the ac voltage regulator VR1 through the closed contacts of generator control relay K5.

Placing the dc POWER switch S5 in the dc POWER position energizes field control relay K11. B1 and B2 contacts of K11 close. The circuit between dc voltage regulator VR2 and the field of dc generator G2 is now complete. Battery voltage, reduced to approximately 1 Vdc by resistor R5, is fed through diode CR4 into the dc voltage regulator at pin C to boost the residual magnetism of the generator and ensure buildup of output voltage. After the generator

voltage has built up, GEN ON light DS20 illuminates and a 28-volt dc signal is fed through diode CR3 into the voltage regulator at pin C. A loss of this signal can cause a dc voltage shutdown.

With the dc output cable connected to the aircraft, distribution is accomplished by pressing the dc SERVICE CABLE ON button S25. This energizes the dc output power relay K10, completing the circuit to dc service output jack J6. The dc SERVICE ENERGIZED light DS19 illuminates, indicating that relay K10 has energized and dc power is available for distribution.

Overvoltage relay K25 is connected to the B+ output of the dc generator G2. It senses any overvoltage not corrected by the dc voltage regulator VR2. When energized it, in turn, energizes lockout relay K12. Lockout relay K12 then de-energizes field control relay K11, removing the 28-volt dc signal from the voltage regulator's pin C and stopping generator output. Output power relay K10 de-energizes if dc servicing is in progress. After an overvoltage shutdown, the lockout relay K12 remains energized until you place the dc POWER switch S5 in the OFF (shown) position.

AC POWER CONTROL AND DISTRIBUTION.—For the discussion of the ac power control and distribution, refer to figure 7-45, a simplified schematic of the ac power control and distribution circuit, and figure 7-46, a picture of the ac control panel.

Prior to ac power distribution, the engine must be operating and the mode selector switch S29 must be in the SERVICE POWER position. The engine is controlled in the same way that it is under dc power control and distribution.

The ac generator output is controlled by the voltage regulator VR1. It is protected from malfunction by the time delay relay K3, over/under voltage relay K7, and the over/under frequency relay K8. Other protective devices are the phase sequence relay K9, the fault lockout relay K6, and the circuit breakers CB1, CB2, and CB3.

Relay K3 is a thermal time-delay relay set to energize 5 to 10 seconds after voltage is applied to the coil. This time delay allows the ac generator to stabilize at the rated voltage and frequency. When K3

is activated, contacts 5 and 7 close, arming the fault relay K6.

CAUTION

Approximately 30 seconds are required to cool the thermal control circuit within relay K3. Therefore, in the event of a fault, the mode selector switch S29 should be placed in the SERVO BOOST or the START/DRIVE position and the engine permitted to idle. If the unit is operating properly, this amount of time is required prior to going into the SERVICE POWER position again.

With switch S29 in the SERVICE POWER position, the ac generator field control relay K5 energizes through the normally closed contacts C2 and C3 of relay K6. The field flash voltage is provided by the permanent magnet generator (PMG) located inside G1. This completes the field circuit and the voltage regulator VR1 circuit. The engine accelerates and stabilizes at approximately 2,400 rpm by the engine governor.

Relay K3 does not energize for 5 seconds. This time delay allows the ac generator to reach its rated voltage and frequency and prevents the inadvertent tripping of fault relay K6.

At the rated voltage and frequency, relays K7 and K8 energize. This opens circuits to relay K6 and closes circuits to the ac SERVICE ON button S23 and ac GEN ON light DS1. The ac generator is now ready for use.

After the ac cable is connected to the aircraft, pressing ac SERVICE ON button S23 energizes relay K2, completing the circuit to ac service output connector J2. The ac SERVICE ENERGIZED ON light DS2 lights, indicating that relay K2 is energized and ac power is available for distribution. K2 is battery operated. Contacts No. 1 and No. 2 close to complete a holding circuit. K2 remains energized until the ac SERVICE OFF button is pressed or a fault occurs.

The phase sequence relay K9 is attached to the three output phases of the ac generator. The phases must be in the proper sequence—A, B, and C. If two phases are reversed, K9 will not energize and close the normally open contacts 5 and 6. This prevents the use of the output circuits, although 115 volts are available on each phase.

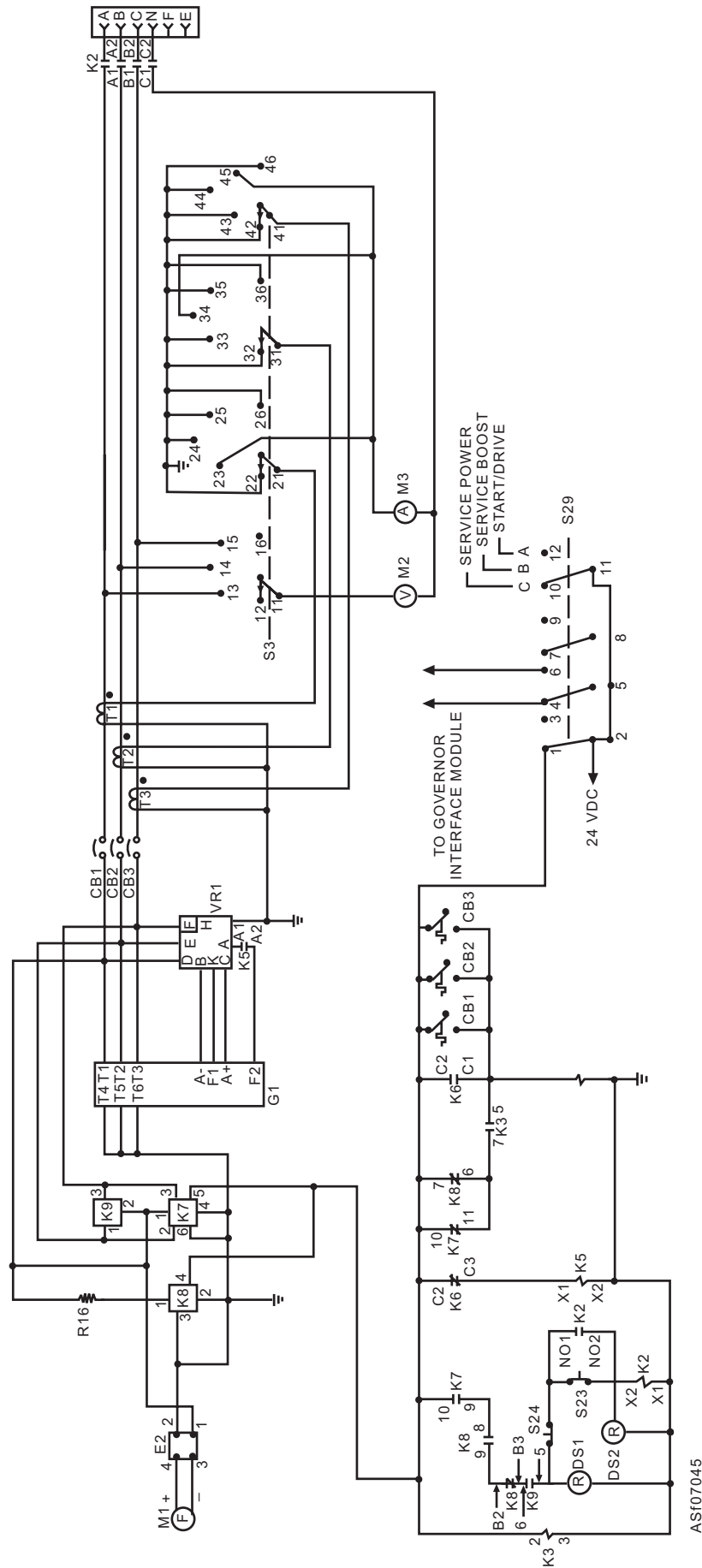
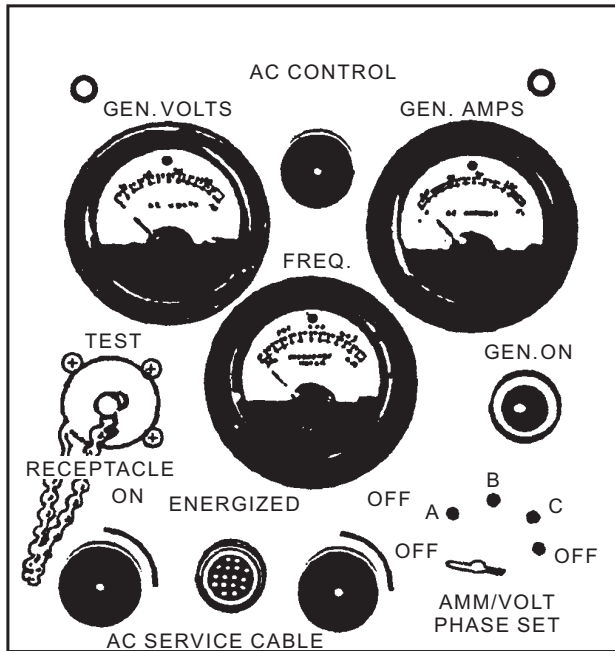

Figure 7-45.—AC power control and distribution circuit.



ASf07046

Figure 7-46.—AC Control panel.

The over/under relay K7 samples the voltage of the three phases. As long as the output of each phase remains between 104-122 Vac, K7 remains energized. Should the voltage exceed either limit, K7 de-energizes and contacts 10 and 11 close. This provides a path for current flow in the fault relay circuit, and K6 energizes. The generator field relay K5, the governor control relay (not shown), and the output service relay K2 are turned off simultaneously. The output cable is also turned off, the generator output is interrupted, and the engine speed returns to idle.

The over/under frequency relay K8 is designed to operate at 400 hertz \pm 10 hertz. If the generator exceeds either limit, K8 de-energizes and contacts 6 and 7 close. This energizes the fault relay K6 as described above. An excessive service load can trip the circuit breakers CB1, CB2, or CB3 with the same result.

NC-8A MOBILE ELECTRONIC POWER PLANT

The NC-8A is a mobile electric power plant that is used to service and start rotary or fixed-wing aircraft (fig. 7-47). The prime mover is a four-cylinder, two-stroke cycle diesel engine controlled by an electrohydraulic governor. The NC-8A is capable of providing 400-hertz, three-phase, 115/200 Vac, 60-kVA power and 28 Vdc at 500 amperes continuously. It can provide 28 Vdc at 750 amperes intermittently. The ac and dc power may be supplied

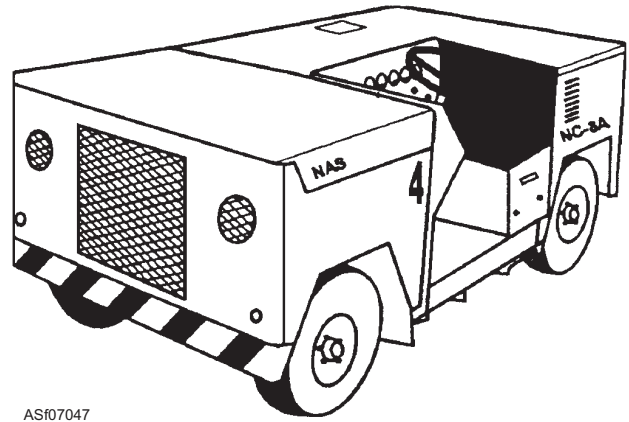

ASf07047

Figure 7-47.—NC-8A mobile electric power plant.

simultaneously, provided the total output power does not exceed 48 kilowatts.

The unit is capable of attaining a speed of 20 mph on smooth level terrain. It can operate at the same speed forward or reverse. Propulsion is provided through a 7.7 horsepower electric motor. The propulsion motor is a reversible, variable-speed, 28-volt dc motor. The motor drives the rear wheels through an automotive-type differential. The speed is controlled by a foot-operated accelerator pedal. The direction of travel is controlled by a switch mounted on the instrument panel.

Electrical Power System

The generator is a combination ac and dc unit (fig. 7-48). It has a single main shaft connected to the power plant by a driving disc. The main shaft turns at the same speed as the power plant. This provides relative motion for the ac and dc sections of the generator. The dc section of the generator contains a stationary field and a rotating armature. The output of the armature is delivered through a commutator and brushes. Access plates allow easy access to the brushes. The output of the dc generator is controlled by a solid-state electronic voltage regulator. It is protected from overvoltage by an overvoltage relay. An overvoltage condition activates the fault circuit, which causes the power plant to release from governed speed and return to idle.

The ac section of the generator converts mechanical power to electrical power by induction. It has a rotating field and stationary output windings. Induction occurs as a result of the relative motion of the rotating field. The electromagnetic field is caused by a dc current passing through the field windings. The rotation of the field induces the alternating current in the stator coils. The three-phase stator is

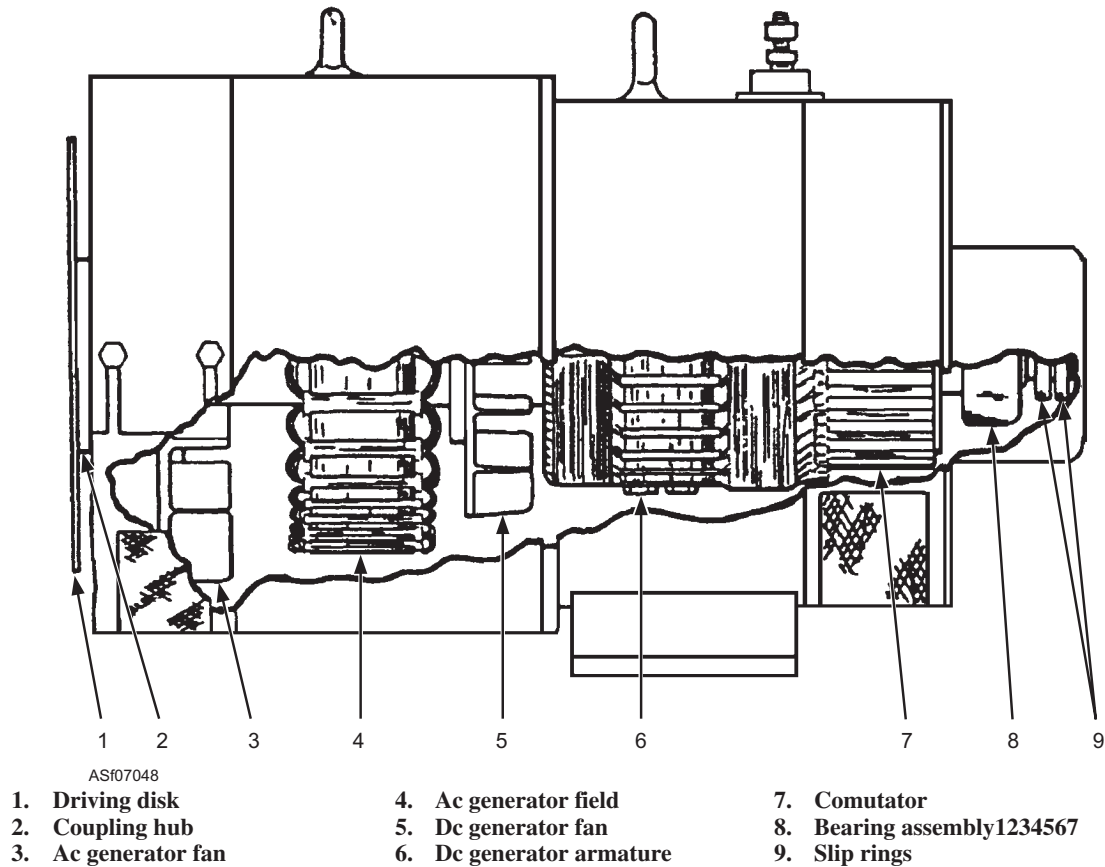

Figure 7-48.—Cutaway view of an NC-8A generator.

wye-connected to produce 115/200 Vac. The maximum output of the alternator is 168 amperes, 60 kVA. It is electronically protected from improper voltage and frequency.

Protective System

The protective system is designed to prevent damage to the engine, generator, propulsion system, and electrical systems as a result of a fault condition.

Circuit breakers provide overload protection for the ac and dc generators.

An integral part of the protective system is the fault locator with its associated relays and fault-sensitive devices. The fault locator automatically shuts down or idles the engine, deactivates the generator, opens the load contactors, and/or deactivates the propulsion system if a fault occurs. It is positioned on the generator control panel; it enables you to determine which of the following conditions activates the fault locator's protective circuitry:

- The ac over/undervoltage
- The over/underfrequency
- The dc overvoltage

- The high engine coolant temperature
- The low fuel supply
- The low engine oil pressure

A reset button is provided to return the fault locator circuitry to the operating condition after the malfunction has been corrected.

Overvoltage Relay

The overvoltage relay is located in the electrical control box. It is a sealed electronic unit designed to protect the generator and the unit being serviced from damage due to excessive voltage. It is connected to each of the three phases of the generator output (K10, fig. 7-49). The overvoltage relay works in conjunction with the fault indicator assembly and the generator fault relay. If an overvoltage fault occurs, the relay contacts close. This signals the malfunction to the fault indicator assembly. The fault indicator energizes the coil of generator fault relay K9. This causes the engine to return to idle, and opens the ac output relay.

The overvoltage relay (fig. 7-50) continually samples all three phases of the ac generator output. The outputs are connected to terminals A, B, C, and N of the

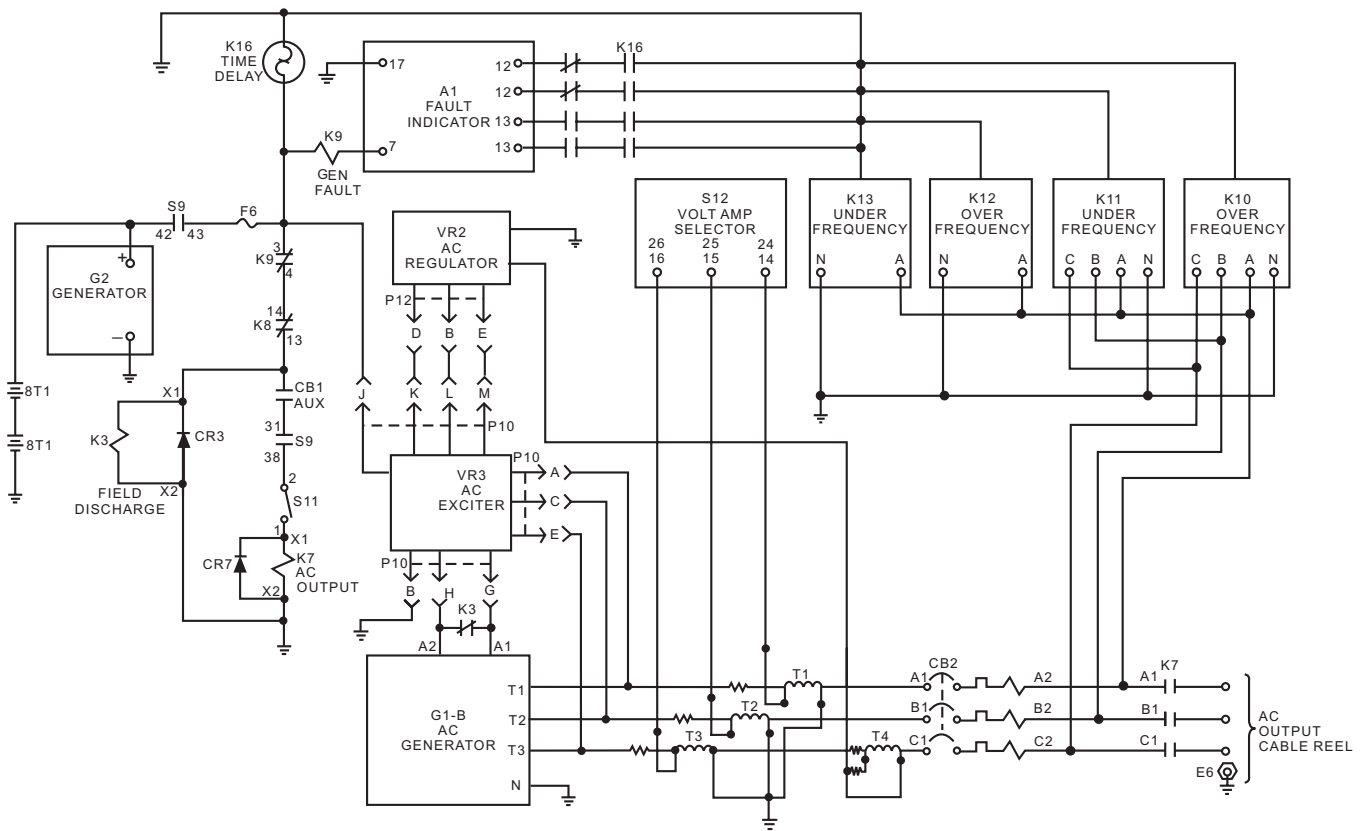

	14-15	22-23	27-28	31-38	34-35	42-43	46-47
OFF							
PROPULSION							
START/IDLE							
OUTPUT POWER							

ASf07049

Figure 7-49.—AC power output system, simplified schematic.

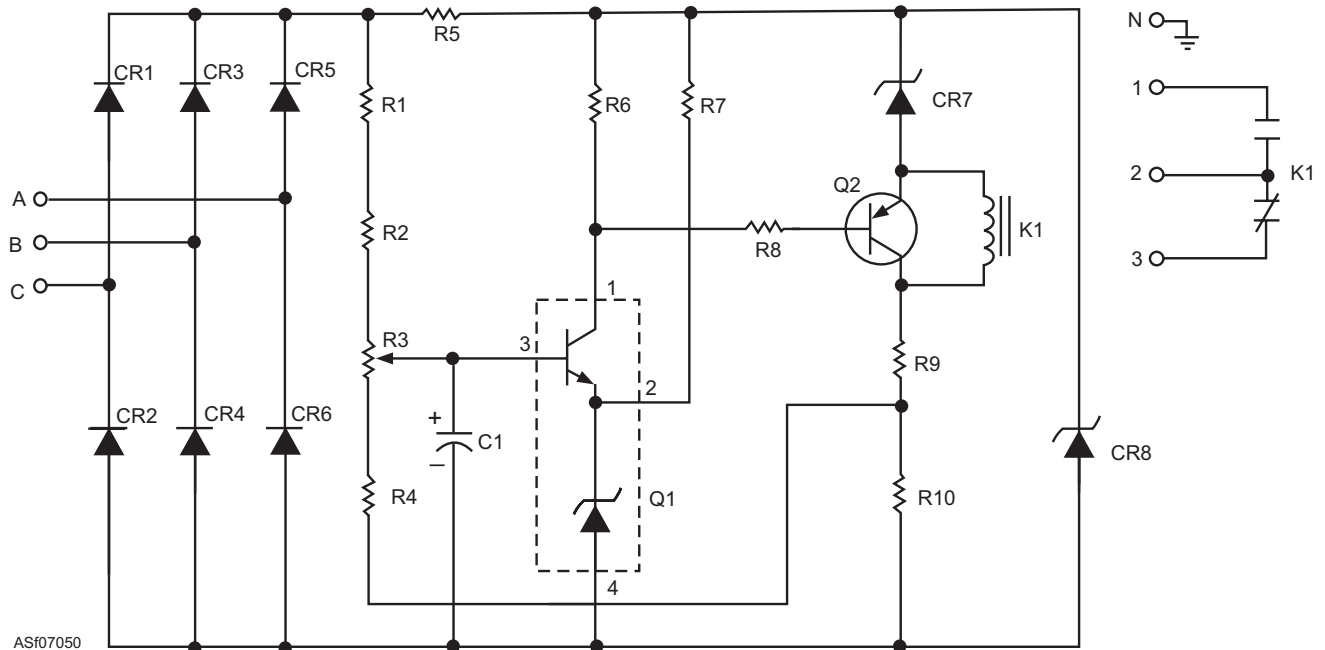

ASf07050

Figure 7-50.—Ac overvoltage relay, simplified schematic.

module. This three-phase alternating voltage is rectified by a full-wave, three-phase bridge network consisting of diodes CR1 through CR6.

The magnitude of this rectified voltage is directly proportional to the ac input voltage. Simply stated, if the ac input voltage at terminals A, B, or C is increased, the rectified voltage increases. The rectified voltage is impressed across the self-bias circuit of transistor Q1. The base voltage of Q1 is provided by the voltage divider circuit consisting of R1, R2, R3, R4, and R10. R3 is a potentiometer. The setting of R3 determines the voltage divider ratio and the voltage at which Q1 saturates. Capacitor C1 reduces the ripple component of the rectified voltage and maintains a more stable base voltage.

Resistor R5 drops a proportionate amount of the rectified voltage, and Zener diode CR8 regulates the resultant voltage rise to a fixed value. This determines the collector supply voltage of Q1 and the emitter supply voltage of Q2. The base voltage for Q2 is provided through resistor R8 when Q1 is conducting. Transistor Q2 is connected in parallel with the operating coil of relay K1. When Q2 is not operating, K1 energizes.

During normal operation the ac input voltage is not sufficient to forward bias Q1. This causes Q2 to turn off and relay K1 to energize. This opens contacts 2 and 3, which are in series with the fault locator (fig. 7-49). When the ac input increases to 130 ± 2.6 Vac or greater, the voltage at R3 increases sufficiently to forward bias

Q1. With Q1 conducting, the proper base voltage for Q2 is provided. Transistor Q2 is forward biased, which shorts the voltage for K1. Relay K1 de-energizes and contacts 2 and 3 close. The closed contacts signal an overvoltage fault to the fault locator board. The fault locator energizes the generator fault relay K9, which causes the generator to turn off and the engine to idle.

The following paragraphs describe the operation of the fault locator when the overvoltage signal is received. (Refer to figure 7-51, the simplified schematic of the fault locator board, and figure 7-52, the fault indicator switch circuit.)

When the fault indicator switch is in the RUN position and the reset switch closed, +24 Vdc is impressed on terminals 5 and 7 (fig. 7-51). The silicon-controlled rectifiers (SCR) Q1 through Q6 are in an OFF condition. To be turned on, an SCR must have a positive potential available at the anode, a negative potential at the cathode, and a positive potential at the gate. The gate voltage must be positive in relation to the cathode voltage. Once the SCR is turned on, it continues to conduct until the anode potential is broken.

When an overvoltage occurs at K10 (fig. 7-52), contacts 2 and 3 close. This presents the full battery/voltage to terminal 12 of the fault locator (fig. 7-51). The 24 Vdc is impressed across the voltage divider circuit from terminal 17 (ground), R15, R9, and R2. The positive gate voltage for Q2 is taken from a point between R15 and R9. This voltage is more

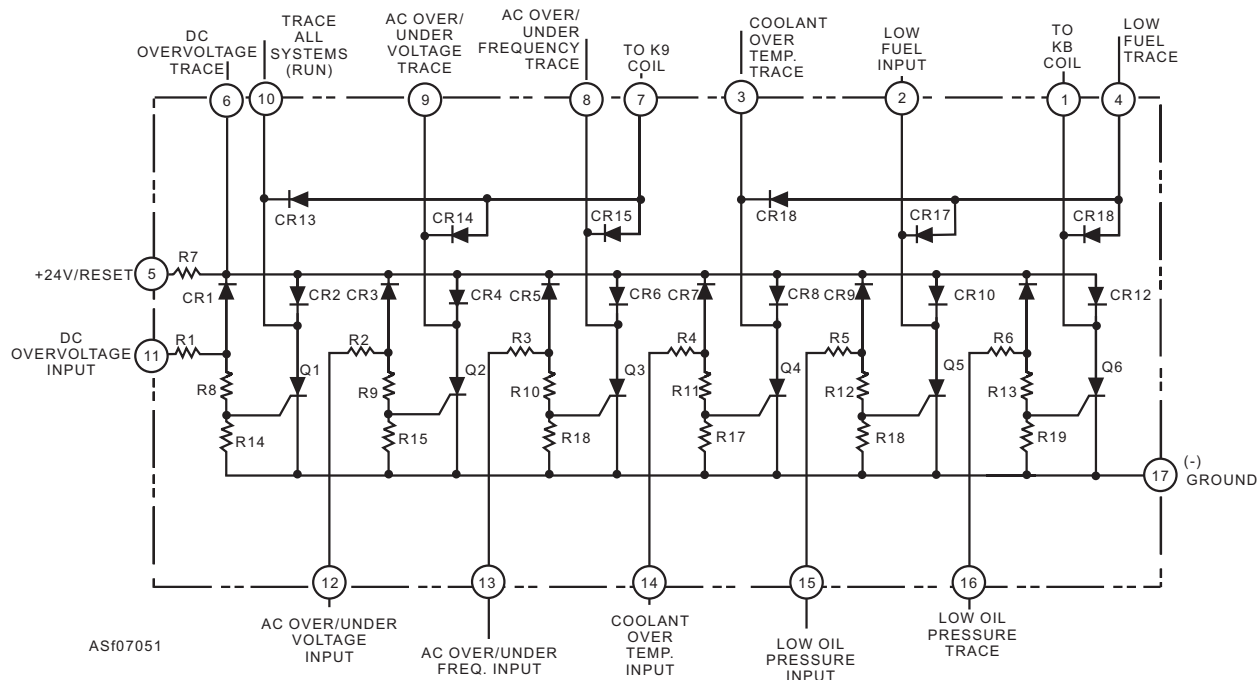
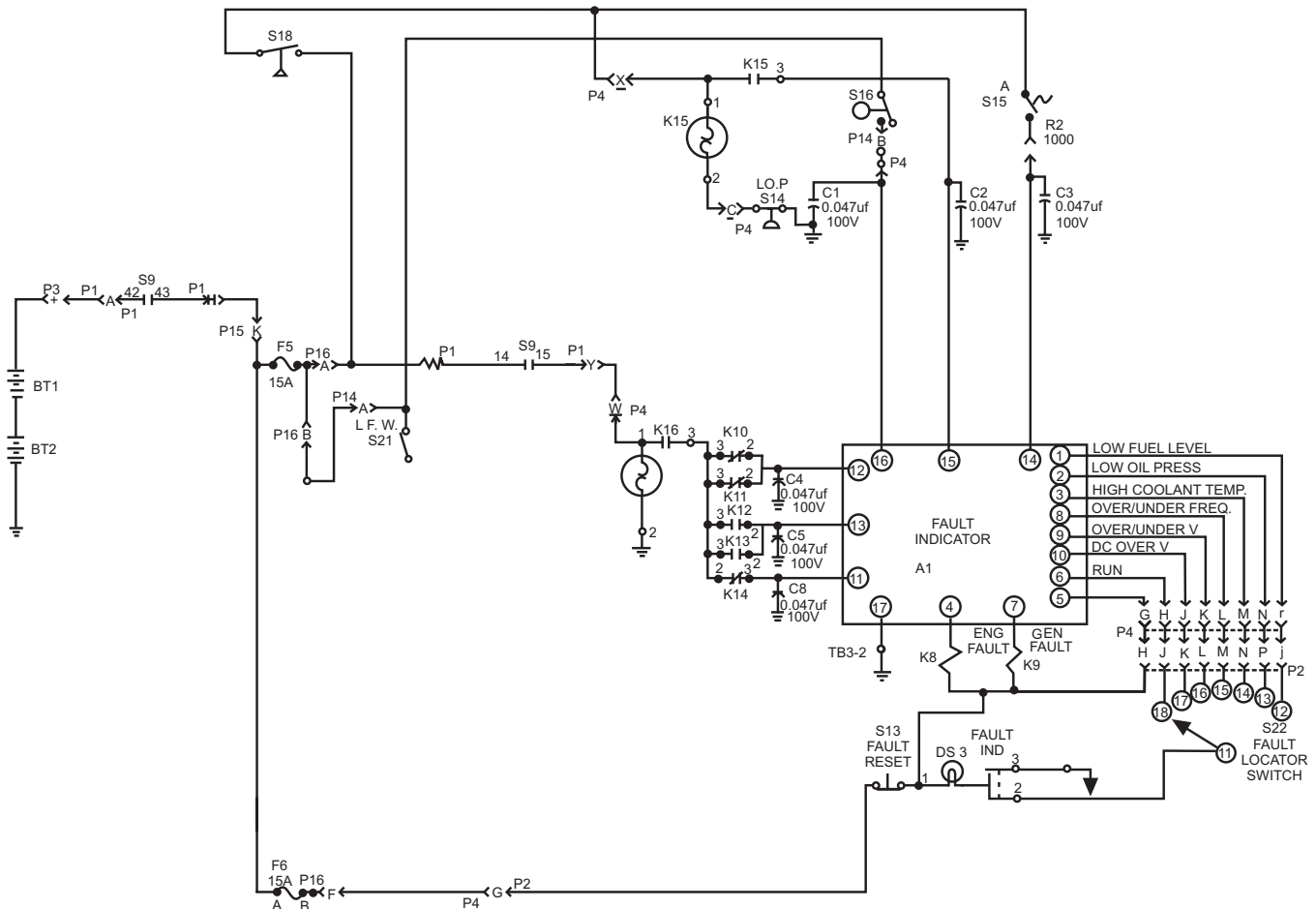

Figure 7-51.—NC-8A fault board.



ASf07052

Figure 7-52.—Simplified schematic for fault locator switch.

positive than the cathode voltage. The SCR Q2 is then turned on. A path for current flow is created from the ground potential (terminal 17) through Q2 and CR14 to energize the generator fault relay K9 (fig. 7-52). A path for current flow is also created through Q2 to CR4 (fig. 7-51) and to terminal 6. The negative path provided here completes the circuit for the fault locator switch and fault indicator light. The fault light comes on, indicating that a fault has occurred. You can identify the type of fault by turning the fault locator switch. The fault light will go out until the switch is turned to the OVER/UNDER VOLTAGE position. Then the fault light comes on.

Vehicle Propulsion and Control System

A dc series traction motor converts the dc generator output into mechanical power to drive the vehicle (fig. 7-53). With the mode selector switch set to the PROPULSION position, excitation to the dc generator is kept constant at battery voltage level. Variations of vehicle speed are obtained by varying the input voltage to the motor. The vehicle operator

depresses the accelerator pedal to vary the speed reference signal to the electrohydraulic governor. Varying this reference signal causes the governor to change engine speed, which changes the generator output. The vehicle's direction is controlled by a relay circuit that reverses the polarity of the voltage delivered to the traction motor. A speed-sensitive switch prevents changing the direction of travel if speeds are greater than 3 miles per hour.

NC-10C MOBILE ELECTRIC POWER PLANT

The NC-10C (fig. 7-54) is a diesel engine-driven unit designed for shore station use. This unit supplies 90 kVA at 0.8 PF, 115/200 volts, three-phase, 400-Hz power for servicing, starting, and maintaining helicopters and jet aircraft. A portion of the electrical power generated is rectified to supply 28 volts dc at 750 amperes (1,000 amperes intermittent) for aircraft starting.

The power plant is self-contained, requiring no external electrical or mechanical source of power. It

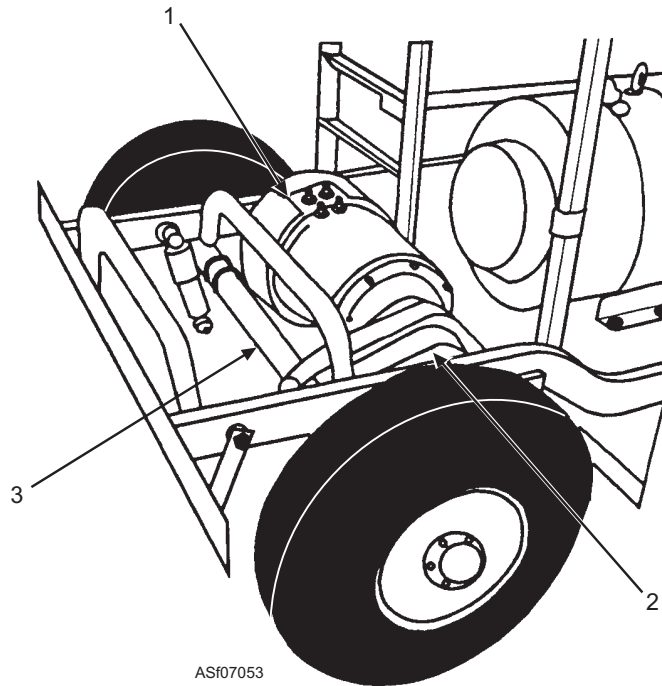

ASf07053

1. Dc drive motor
2. Differential and gear drive
3. Rear axle

Figure 7-53.—NC-8A self-propulsion package.

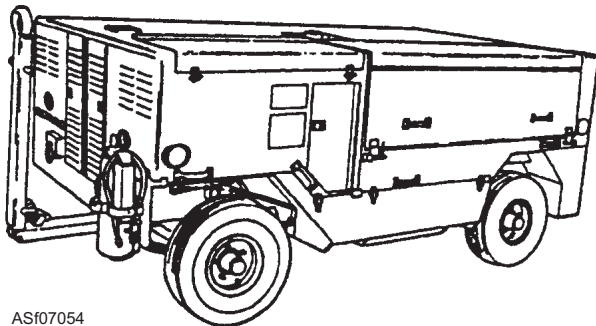

ASf07054

Figure 7-54.—NC-10C mobile electric power plant.

operates efficiently at altitudes ranging from sea level to 8,000 feet.

The power plant is enclosed in a steel housing. The housing is fabricated in two sections, which are easily removed to service the unit. Operating components are mounted on a four-wheel trailer, which is equipped with mechanical internal expanding wheel brakes. The brakes may be set by a hand lever.

Double-hinged doors provide access to the control panel, starting components, and three output power cables.

The plant's electrical system is protected from overload by output circuit contactors, circuit breakers, overvoltage and undervoltage relays, overfrequency

and underfrequency relays, thermal overload relays, and fuses.

Power generation, both dc and ac, is controlled by the operator from the control panel located at the left front of the unit. The control panel contains four functional groups of instruments—the electrical receptacles and adjustable resistors, the ac controls, the dc controls, and the engine controls.

DC Power System

The dc power supply of the NC-10C is obtained from a six-phase, full-wave transformer-rectifier, by using three-phase, 400-Hz, 115/200-volt generator output as a power source. The dc output voltage is regulated by a two-stage magnetic amplifier circuit. The output dc voltage range is 22 to 39 volts. The voltage is regulated within ± 0.5 volt at no load up to full load (750 amperes). The maximum output is 28 Vdc at 750 amperes continuous duty, or 1,000 amperes intermittent (15 second on and 45 second off) for 8 consecutive cycles applied to the dc cable).

Protective relays protect the power supply from current and voltage overloads. A cable is provided for connection of dc power to aircraft. A cable reel is provided for cable stowage.

AC Power System

The NC-10C is equipped with an ac generator that develops 90 kVA at 0.8 PF, 115/200 volt, three-phase, four-wire, 400-Hz power when driven at 1,846 rpm. Generator field flashing and excitation are provided by a 24-volt battery. When the engine is running, excitation is supplied by a magnetic amplifier-type voltage regulator.

The ac voltage regulator is also a two-stage magnetic amplifier type. The regulator supplies total power to the ac generator field circuit and regulates the output voltage within 1 percent no load to full load. The input to the voltage regulator is 200 volts, three-phase, 400-Hz power. The ac power system is protected from overload, overvoltage, undervoltage, and frequency variations by appropriate protective devices.

The ac output voltage is applied to aircraft through two 30-foot cables, which are contained on separate return reels that have automatic ratchet stops. Collector rings and brushes within the reel hubs provide continuous electrical contact through the cable.

Q7-17. Which of the following statements best describes the propulsion system of the NC-2A mobile electric power plant?

- 1. It is a 28 Vac, front axle, reversible, variable-speed motor*
- 2. It is a 28 Vdc, rear axle, reversible, variable-speed motor*
- 3. It is a 28 Vdc, rear axle, reversible, fixed-speed motor*
- 4. It is a 28 Vdc, front axle, reversible, variable-speed motor*

Q7-18. What is the total number of generators located on the NC-2A mobile electric power plant?

- 1. One*
- 2. Two*
- 3. Three*
- 4. Four*

Q7-19. What is the ac output of the NC-2A mobile electric power plant?

- 1. 115/200 Vac, 3-phase, 4-wire, 400 Hz*
- 2. 220/440 Vac, 3-phase, 3-wire, 60 Hz*
- 3. 115/220 Vac, single-phase, 3-wire, 400 Hz*
- 4. 220/440 Vac, 3-phase, 4-wire, 60 Hz*

Q7-20. What is the maximum dc amperage output of the NC-2A mobile electric power plant?

- 1. 100 amps*
- 2. 350 amps*
- 3. 500 amps*
- 4. 750 amps*

Q7-21. Which of the following switches is used to energize relay K-5 in the dc power control circuit?

- 1. S-5*
- 2. S-25*
- 3. S-26*
- 4. S-29*

Q7-22. Relay K-3 in the ac power control and distribution circuit of the NC-2A mobile electric power plant is what type of relay?

- 1. A power distribution relay*
- 2. A thermal time-delay relay*
- 3. A circuit control relay*
- 4. A fault protection relay*

Q7-23. Which of the following components provides overload protection for the ac and dc generators in the NC-8A mobile electric power plant?

- 1. The fault board*
- 2. The circuit breakers*
- 3. The fault relays*
- 4. The fuses*

MMG-1A MOBILE MOTOR-GENERATOR SET

LEARNING OBJECTIVE: Identify the components of mobile motor-generator sets (MMGs).

Mobile motor-generator sets (MMGs) perform the same function as the MEPPs, but they are not self-contained and require an external source of electrical power for operation. The MMGs are used primarily in hangars on shore stations or on the hangar decks of aircraft carriers where the running of an internal combustion engine would be objectionable and where external power is readily available.

The MMG-1A is a mobile motor generator (figs. 7-55 and 7-56). It is mounted on a mobile chassis assembly and steered by a tow bar that is mechanically attached to the front wheels. It is easily maneuvered by hand or by a tow tractor. The maximum towing speed is

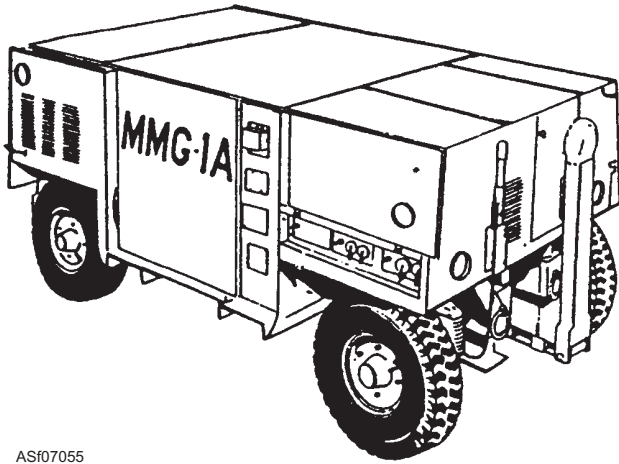

ASf07055

Figure 7-55.—MMG-1A mobile motor-generator set (external view).

5 mph. The power plant may be positioned on any flat surface where 220/440-Vac, three-phase, 60-hertz power is available. Approximately 3 feet of clear space should be maintained on all sides of the unit for easy access during operation and maintenance. Ample clearance is also required for adequate cooling and air circulation. Hinged doors and removable panels are

provided for easy access to all major systems for maintenance. They must maintain a watertight seal.

The MMG-1A operates on 220 Vac or 440 Vac by changing the strapping on the two-change boards. You must check the change boards before using the unit. The ac input change board (fig. 7-57) and the dc input board (fig. 7-58) must be properly configured to receive the input voltage. As shown, when the 440-volt input is used, double strapping bars must be used. If the input cable connector plug has to be changed, be sure it is wired correctly. The motor generator circuit is equipped with a reverse-phase sequence relay. This relay prevents the motor start circuit from energizing if the phases are reversed.

Be sure the input cable is disconnected before you attempt to change the board. When the power plant is to be used aboard an aircraft carrier, the ground wire on the power transformer must be removed and well insulated. This is necessary because of the floating ground of the ship's power supply. This prevents the dc power supply from arcing to the power plant chassis. The wire must be reinstalled before you return the unit to a shore-based facility.

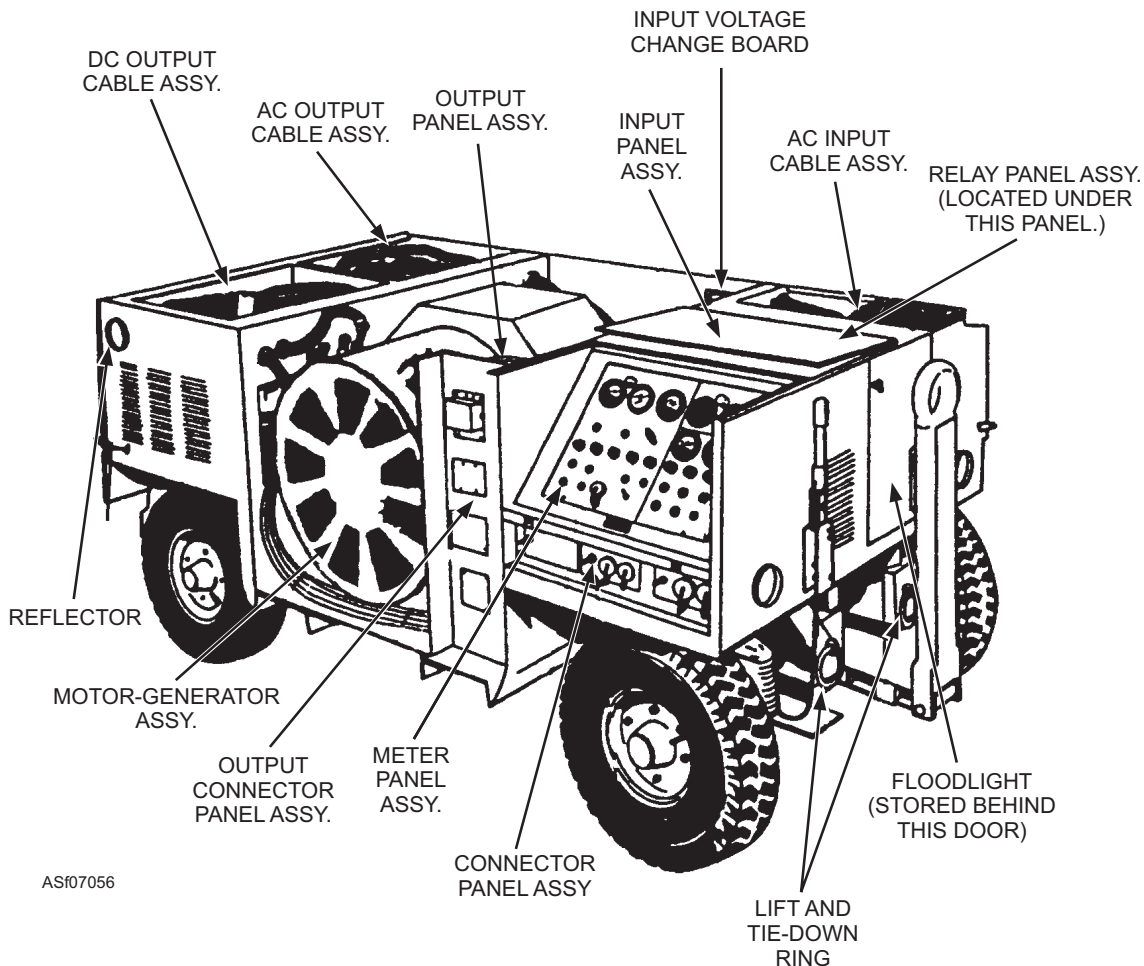

ASf07056

Figure 7-56.—MMG-1A mobile motor-generator set (internal view).

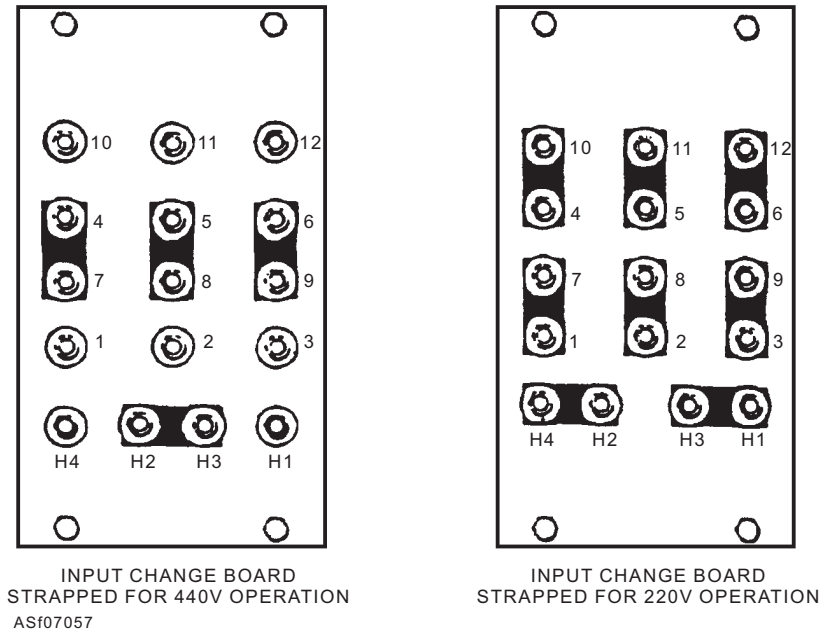
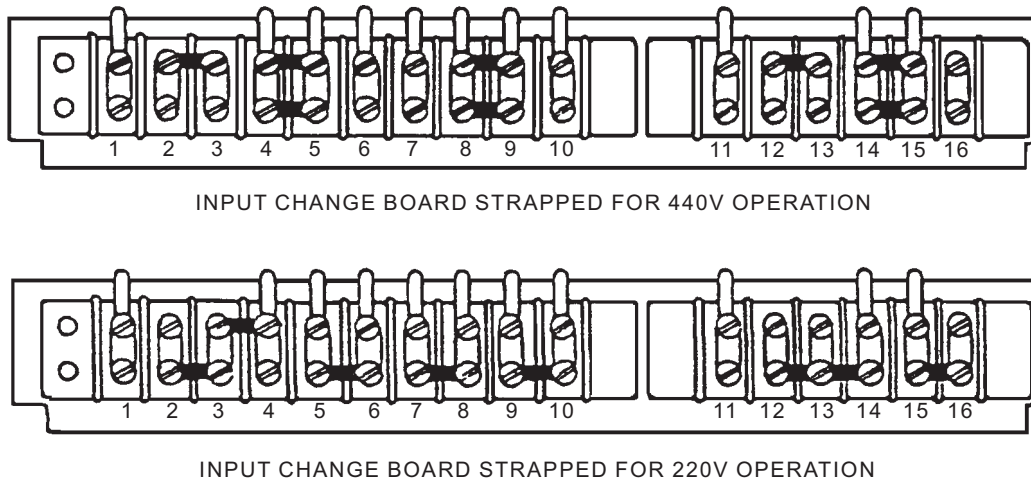

Figure 7-57.—AC input change board.



ASf07058

Figure 7-58.—DC input change board.

An 80-horsepower electric motor drives the ac generator. The generator output is rated 115/200 Vac at 60 kVA. One phase of the input voltage is stepped down to 28 volts by a transformer and rectified for direct current. It is capable of supplying 500 amperes continuously and 1,000 amperes intermittently for starting only. The ac and dc outputs are monitored and controlled by an electronic voltage regulator and fault protection module. The module consists of a motherboard assembly and four removable printed circuit board inserts. The module ensures a stable generator output. If the output deviates, it energizes a fault relay to protect the generator and the unit being serviced.

Q7-24. In which of the following locations is the MMG-1A primarily used?

1. In the hanger bays of shore stations and aircraft carriers
2. On the flight line of shore stations
3. On the flight deck of an aircraft carrier
4. On the flight deck and hanger bays of aircraft carriers

Q7-25. What is the input voltage required to run the MMG-1A?

1. 115 Vac, 400 Hz
2. 220 Vac, 400 Hz
3. 15/200 Vac, 60 Hz
4. 220/440 Vac, 60 Hz

ELECTRICAL SYSTEM MAINTENANCE

LEARNING OBJECTIVE: Recognize procedures for troubleshooting and maintaining MEPP and MMGs.

MEPPs and MMGs, like most complex support equipment, are inspected prior to each use and periodically as required by the equipment manuals and the periodic maintenance requirements cards (MRCs). In some cases, local conditions may require more frequent inspections than the MRCs. But, in no instance should the interval between inspections exceed the time specified on the MRCs.

Generally speaking, whenever troubles or irregular operating characteristics are observed in this equipment, you can trace it to improper maintenance and operation or to a malfunctioning component. Efficient maintenance of any system depends upon the skill and proficiency of the operating and maintenance personnel. This MEPP offers no exception to this rule.

The check, test, and repair of this unit require the use of different kinds of test equipment and general tools. Most technical manuals give a list of all special tools required for repairing the equipment.

NOTE: The troubleshooting and maintenance procedures addressed in this text are very general in nature, and may apply to any of the MEPPs discussed in this course.

TESTING

Performance and calibration tests must be completed on this unit to determine its ability to operate within prescribed limits under both no-load and full-load conditions.

The calibration tests for this MEPP require the extensive use of test equipment. The use of this equipment and the procedures for calibrating such units as voltage regulators, meters, protective packages, and checking harmonic distortions are beyond the scope of this NRTC. To perform calibration tests, or any other type of maintenance, always refer to the appropriate technical manual. This NRTC is not to be used as a technical manual for any piece of support equipment.

Operational testing of dc generators is required when a generator is replaced or repaired. This includes brush replacement, disassembly, and reassembly.

Generally, after reassembly, the generator is reinstalled in the unit it was taken from to seat the brushes and perform operational tests.

Typical testing procedures are as follows:

1. If you install new brushes, run the generator for 20 to 30 minutes with no load to permit the brushes to seat.
2. Place an external load on the generator, not to exceed its rating.
3. If operation is satisfactory, stop the engine and replace the generator brush covers.
4. Reposition the dc shunts.
5. Replace all panels and door assemblies and secure them properly.
6. Adjust the generator to its rated output.

Testing procedures vary, and it is beyond the scope of this course to discuss all methods used for testing dc generators. You should consult the applicable manuals to determine the correct procedures for specific generators.

TROUBLESHOOTING

A large portion of your time is spent troubleshooting or supervising the troubleshooting procedures of others in maintaining assigned support equipment.

Generator failures or apparent failures are due to a variety of causes. Before you remove a generator, take the time to diagnose it properly. An apparent failure can be caused by a malfunctioning control or regulating system. Troubleshooting charts similar to table 7-4 are located in the manufacturers' manuals. They contain many probable causes and remedies for troubles found in dc generating systems.

Procedures performed at the intermediate level include normal maintenance, replacement of brushes, diodes, and engine and generator control components. Major repairs, such as rewinding armatures and field coils, are done at the depot maintenance activity.

“Troubleshooting” refers to the detection and location of a malfunction by an orderly and systematic procedure. To troubleshoot efficiently or supervise effectively, a minimum of the following information must be known:

- What the system is supposed to do in normal operation and how to operate it.

Table 7-4.—DC Generator Troubleshooting Chart

Probable Cause	Remedy
Failure to Build Up Voltage	
Open field resistor	Repair or replace resistor.
Open field circuit	Check coils for open and loose connections. Replace the defective coil or coils. Tighten or solder loose connections.
Absence of residual magnetism in a self-excited generator	Flash the field.
Dirty commutator	Clean or dress commutator.
High mica	Undercut mica.
Brushes not making proper contact	Free, if binding in holders. Replace and reseal if worn.
Newly seated brushes not contacting sufficient area on the commutator	Run in by reducing load and using a brush-seating stone.
Armature shorted internally, or to ground	Remove, test, and repair or replace.
Grounded or shorted field coil	Test, and repair or replace.
Shorted filtering capacitor	Replace.
Open filter choke	Replace.
Broken brush shunts or pigtails	Replace brushes.
Output Voltage Too Low	
Prime mover speed too low	Check speed with tachometer. Adjust governor on prime mover.
Brushes not seated properly	Run in with partial load, use brush-seating stone.
Commutator is dirty or film is too heavy	Clean, or if film is too heavy, replace brushes with a complete set of proper grade.
Field resistor not properly adjusted	Adjust field strength. Tighten all connections. Make shim adjustment.
Reversed field coil or armature connection	Check and connect properly.
Output Voltage Too High	
Prime mover speed too high	Check speed with tachometer. Adjust governor on prime mover.
Faulty voltage regulator	Adjust or replace.
Armature Overheats	
Overloaded	Check meter readings against nameplate ratings. Reduce load.
Excessive brush pressure	Adjust pressure or replace tension springs.
Couplings not aligned	Align units properly.
End bells improperly positioned	Assemble correctly.
Bent shaft	Straighten or replace.

Table 7-4.—DC Generator Troubleshooting Chart—Continued

Probable Cause	Remedy
Armature Overheats—Continued	
Armature coil shorted	Repair or replace armature.
Armature rubbing or striking poles	Check for bent shaft, loose or worn bearings. Straighten and realign shaft. Replace bearings, tighten pole pieces, or replace armature.
Clogged air passages (poor ventilation)	Clean equipment.
Repeated changes in load of great magnitude. (Improper design for the application)	Generator should be used with a steady load application.
Unequal brush tension	Equalize brush tension.
Broken shunts or pigtails	Replace brushes.
Open in field rheostat	Repair or replace rheostat.
Field Coils Overheat	
Shorted or grounded coils	Repair or replace.
Clogged air passages (poor ventilation)	Clean equipment.
Overload (compound generator)	Check meter reading against nameplate rating. Reduce load.
Sparking at Brushes	
Overload	Check meter readings against nameplate ratings. Reduce load.
Brushes off neutral plane	Adjust brush rigging.
Dirty brushes and commutator	Clean brushes and commutator.
High mica	Undercut mica.
Rough or eccentric commutator	Resurface commutator.
Open circuit in the armature	Repair or replace armature.
Grounded, open- or short-circuited field winding	Repair or replace defective coil or coils.
Insufficient brush pressure	Adjust or replace tension springs.
Brushes sticking in the holders	Clean holders. Sand brushes.

- What each part or piece of equipment in the system contributes and how each functions.
- The location of all system components.
- The most likely cause of any given malfunction.
- The best places to “get into” the system for making tests. This information is available in the appropriate technical manuals.

The appropriate maintenance instruction manuals provide troubleshooting procedures that include the malfunction, probable cause, and the repair step. Troubleshooting tables, such as table 7-4, used in

conjunction with the applicable technical repair manuals and electrical wiring diagrams aid greatly in correcting system malfunctions.

GENERAL REPAIRS

In repairing MEPP support equipment, no components or equipments should be rejected until every effort has been made to effect repairs or correct the malfunction at the lowest maintenance level. As the mechanic, you will be the most instrumental person in making such decisions. Your decisions should be influenced by the availability of personnel, availability

of tools and material, location of next higher level of maintenance, and operational needs. To the extent possible, all repairs should be made locally.

REPAIRING POWER CABLES

The power output cables that carry current to start or service aircraft can only function if they are properly constructed and maintained. Improper and nonstandard procedures used in the assembly or repair of cable assemblies and attachable plugs can lead to premature failure and possible safety hazards.

At the local level, repair is limited to the attachable plugs (fig. 7-59). Such procedures include cleaning, torquing, and repairing or installing new conductors and contacts. If the cable itself is cut or worn, it must be replaced. You are not authorized to tape or splice a damaged cable.

Cleaning is accomplished by the use of a .38 caliber wire bore brush and a small amount of Neats® or Vaseline®. After using the wire brush to remove dirt and corrosion in the contacts, wipe them clean with a rag. To ensure all dirt and corrosion have been removed and that no parts of the rag remain in the contacts, inspect each contact after wiping.

Special tools for working on cables are shown in figure 7-60. The rod is used to pull the conductor so it will be properly seated in the plug. The contact holding key allows the hex rod to turn without twisting the contact. Torque of the contacts to the conductors is 70 in-lb. and 50 in-lb for control contacts.

As noted, proper tools and standardized procedures are a must for this job. Correct tinning and crimping procedures are outlined in *Intermediate Maintenance Instructions for Repair and Assembly of External Power Cables and Attachable Plugs*, NAVAIR 17-1-116, as well as the proper steps for replacing a damaged plug.

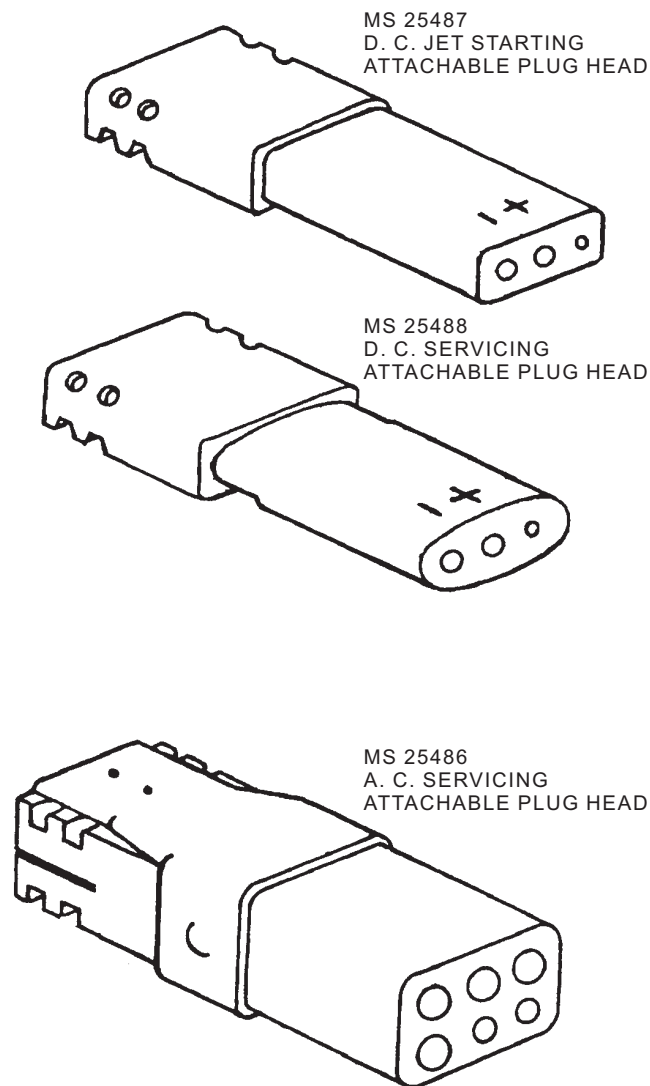

AS107059

Figure 7-59.—Models of attachable head plugs.

Q7-26. What action should you take for repairing a cut or worn power cable?

1. Tape it with electrical tape
2. Splice the damaged area
3. Replace the worn cable
4. Solder a connector over the worn area and insulate it with heat shrink

Q7-27. Which of the following manuals should you use to repair an external power cable?

1. NAVAIR 17-1-110
2. NAVAIR 17-1-116
3. NAVAIR 17-1-125
4. NAVAIR 17-1-129

ELECTRICAL LOAD BANK

LEARNING OBJECTIVES: Identify the components of electrical load banks. Identify procedures for troubleshooting and maintaining electrical load banks.

The electrical load bank or dummy load, as it is often referred to in the fleet, is designed to apply ac and dc test loads to all types of 400-Hz and 28-volt dc power plants. The load bank can also test a motor generator set like the MMG-1A. It is designed for shore-based or shipboard use. Most AS personnel probably recognize this unit as the MLB-1A. With a new manufacturer, however, the designation has

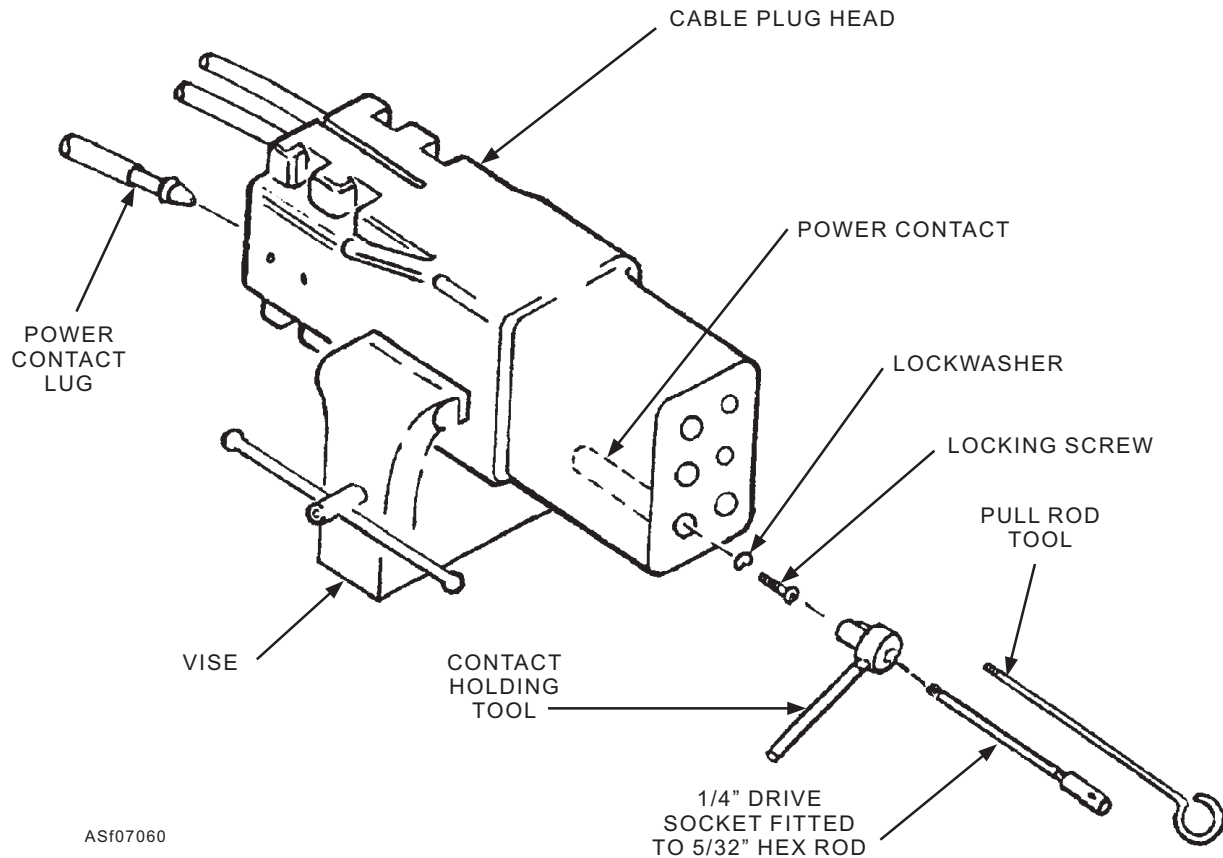

Figure 7-60.—Special tools.

been changed, and it is now known as the DA-675/MSM. There is very little difference between the two units. Table 7-5 lists the basic physical, electrical, and environmental specifications for the load bank.

OPERATING INSTRUCTIONS

The load bank is designed to perform electrical loading tests on power plants rated at either 28 volts dc or 115/200 volts, three-phase, four-wire, 400-Hz. Both

load bank sections (ac and dc) may be operated individually or simultaneously without influencing each other's loading capabilities. A control power circuit in the load bank for supplying power to the cooling fans, lights, and load control relays and contactors is common to both sections. Power for this control power circuit may be taken from either the ac or dc section inputs. When taken from the ac input, the control power is indicated by the ac load meters as part of the total ac load. When taken from the dc input, the control power is indicated as part of the total dc load.

Table 7-5.—Leading Particulars for the DA-675/MSM Load Bank

TRAILER	
Chassis and Running Gear	Welded steel construction; leaf-spring type suspension. Equipped with pintle hook, lifting and tie-down rings, and forklift channels. Travels on four steel wheels, each mounting 6:90 9, 10-ply pneumatic tires and tubes. Normal inflated pressure is 40 pounds.
Towbar	Reinforced steel elliptical construction with welded lunette eye. Removable pivot pin and latch to maintain in vertical position.
Brakes	Mechanical: adjustable, expanding-shoe type acting on two rear wheels. Applied by hand lever.
Enclosure	Removable welded steel weatherproof housing. Hinged doors for operating and servicing accessibility.

Table 7-5.—Leading Particulars for the DA-675/MSM Load Bank—Continued

OPERATING CAPABILITIES	
Ambient Temperatures	-67°F to +160°F (-55°C to +71°C).
Relative Humidity	100 percent.
Altitude	Sea level to 6,000 ft.
Mobility	Maximum towing speed on improved surfaces: 20 mph.
Air Transportability	To 50,000 ft.
Emergency Landing	Horizontal: 8 g
g Force Limits	Vertical: 6 g
ELECTRICAL SYSTEMS CHARACTERISTICS	
28 Vdc, Aircraft Servicing	0 to 1,500 A, continuous resistive loading.
Loading Increments	Variable: 0 to 55 A; Fixed: 50-100-100-200-200-450-450 A
28 Vdc, Jet Starting	0 to 1,500 A, continuous resistive loading.
Loading Increments	Variable: 0 to 55 A; Fixed: 50-100-200-200-450-450 A
28 Vdc, Common Bus	0 to 3,000 A, continuous resistive loading. Aircraft Servicing and Jet Starting sections internally paralleled.
120/208 V, 3-phase, 4-wire, 400 cycles, resistive-reactive loading	0 to 187.5 KVA continuous 1.0 to 0.2 Power Factor Lag (375 KW, 183.7 KVAR).
Loading Increments, Resistive	Variable: 0 to 3.5 KW; Fixed: 3-6-12-24-45-47-47 KW. 187.5 KW total.
Loading Increments, Reactive	Variable: 0 to 3.0 KVAR; Fixed: 3-6-12-15-30-30-30-30 KVAR. 189 KVAR total.
LOAD PROGRAMMING	
28 Vdc, Common Bus	0 to 3,000 A for 5 min. 0 to 3,000 A for 5 sec.
28 Vdc, Split Bus, Hard Start	0 to 1,500 A for 20 sec.
5/28 Vdc, Split Bus, Soft Start	1,000 A for 10 sec followed by 200 A for 10 sec.
120/208 V, ac, 3-phase, 4-wire, 400 cycle, resistive-reactive loading	0 to 281.25 KVA for 5 min, 1.0 to 0.47 P.F. lag 0 to 375.0 KVA for 5 sec, 1.0 to 0.57 P.F. lag.
POWER REQUIREMENTS	
Load Element Cooling Fans	26 to 28 Vdc from input power to dc sections or from ac input power through transformer-rectifier module.
Control Circuit	28 Vdc from input power to dc sections or from ac input power through transformer-rectifier module.
Panel Lights	28 Vdc from input power to dc sections or from ac input power through transformer-rectifier module. Intensity is adjustable.
Extension Light	28 Vdc from input power to dc sections or from ac input power through transformer-rectifier module.
INSTRUMENT SCALES AND NOMINAL ACCURACIES	
DC Voltmeter, 0 to 150 V	Meter: ±1% of full scale. System: ±1% of full scale.

Table 7-5.—Leading Particulars for the DA-675/MSM Load Bank—Continued

INSTRUMENT SCALES AND NOMINAL ACCURACIES—Continued	
DC Ammeter, 0 to 200/400/1000/2000 A	Meter: $\pm 1\%$ of full scale System: $\pm 1\ 1/2\%$ of full scale.
AC Voltmeter, 0 to 150 V	Meter: $\pm 1\%$ of full scale. System: $\pm 1\%$ of full scale.
AC Ammeter, 0 to 200/400/800/1600 A	Meter: $\pm 1\%$ of full scale. System: $\pm 1\ 1/4\%$ of full scale.
AC Single Phase Kilowatt Meter with transducer, 0 to 20/40/80/160 KW	Meter: $\pm 2\%$ of full scale. System: $\pm 2\ 1/4\%$ of full scale.
AC Power Factor Meter with Transducer Unity to 0.20	Meter: $\pm 2\%$ of full scale. System: $\pm 2\ 1/2\%$ of full scale.
AC Frequency Meter with Transducer 350/400/450 cps	Meter: ± 2 cycles at mid-scale (400 cps) and ± 4 cycles at scale extremities. System: ± 2 cycles at mid-scale (400 cps) and ± 4 cycles at scale extremities.

Both ac and dc sections may be continuously operated at full load simultaneously. The 5-minute and 5-second overload tests may be programmed on only one section at a time. However, the section not programmed for timed overload may be operated at full load continuously during overload testing of the other section.

CONTROLS, INDICATORS, AND EXTERNAL CONNECTION FACILITIES

All operating controls, indicators, connectors, and terminal blocks of the MLB-1A are illustrated in figures 7-61 through 7-64 and described in tables 7-6, 7-7, and 7-8.

PREOPERATIONAL PROCEDURE

There are two parts to preparing the load bank for operation, setting up, and connecting to the power source.

Setting Up the Load Bank

To prepare the load bank for operation, proceed as follows:

1. Position the load bank within convenient cable length for connection to the power plant, and then set the parking brake (6, fig. 7-61).

CAUTION

Select an area where the flow of cooling air under and around the unit is assured. The unit dissipates a considerable amount of heat when loads are applied to the power plant under test.

2. Open the two air exhaust doors (1, fig. 7-61).
3. Open the control console cover (7, fig. 7-61).
4. Open the dc panel cover (5, fig. 7-61) and/or the ac input panel cover (4, fig. 7-61) as required.
5. Verify that all toggle switches on the control panels, shown in figures 7-62, 7-63, and 7-64, are in the OFF position.
6. Connect cables from the power plant to receptacles or terminals on the ac or dc input panel (2 or 3, figure 7-61), depending on the power plant to be tested or used.

WARNING

NEVER connect a power plant output cable to the load bank receptacles or terminal blocks while the cable is energized.

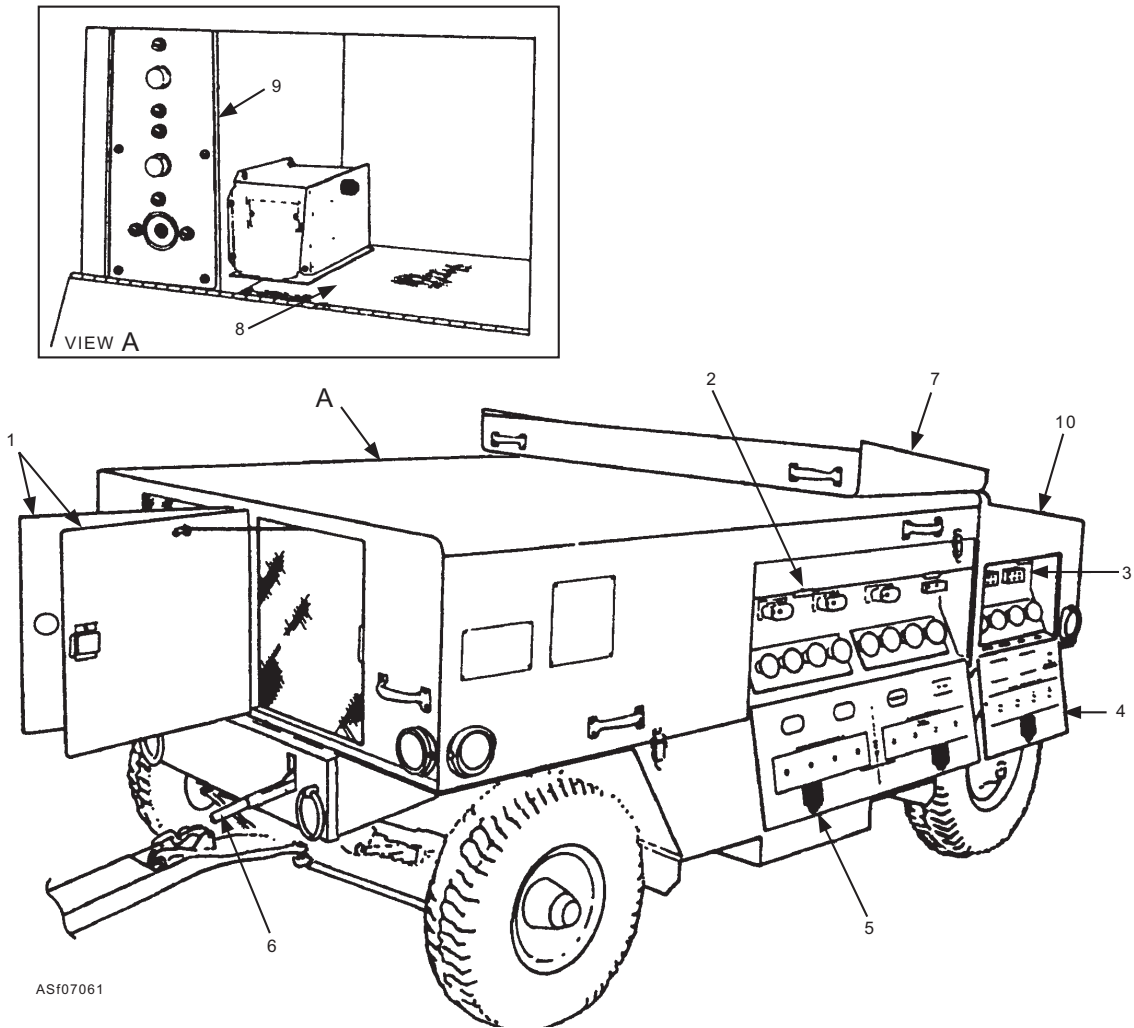

ASf07061

- | | |
|------------------------------|--------------------------------|
| 1. Forward door, air exhaust | 6. Parking brake control lever |
| 2. Dc input panel | 7. Cover, control console |
| 3. Ac input panel | 8. Storage compartment |
| 4. Cover, ac input panel | 9. Circuit breaker panel |
| 5. Cover, dc input panel | 10. Control console |

Figure 7-61.—Load bank with access doors open.

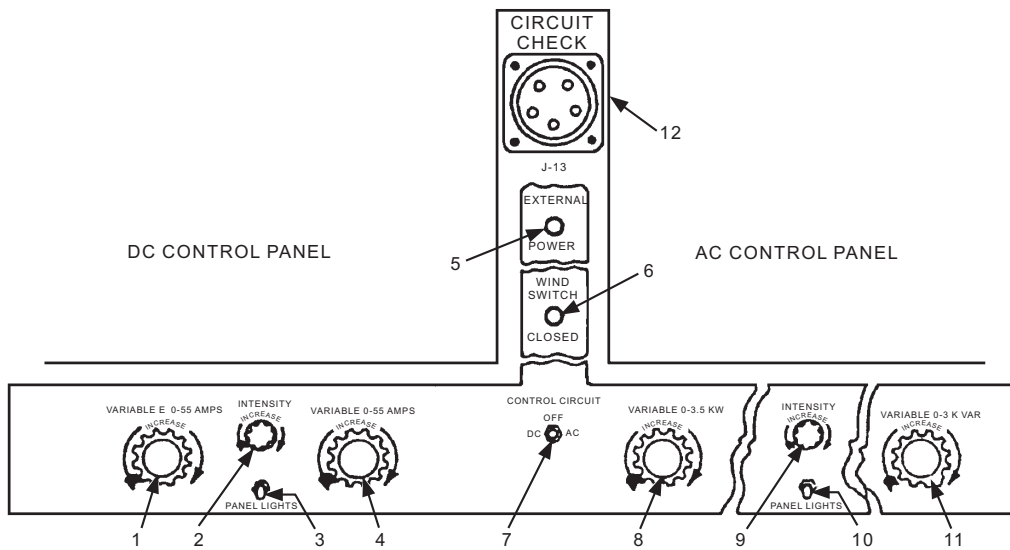

ASf07062

Figure 7-62.—Master control panel.

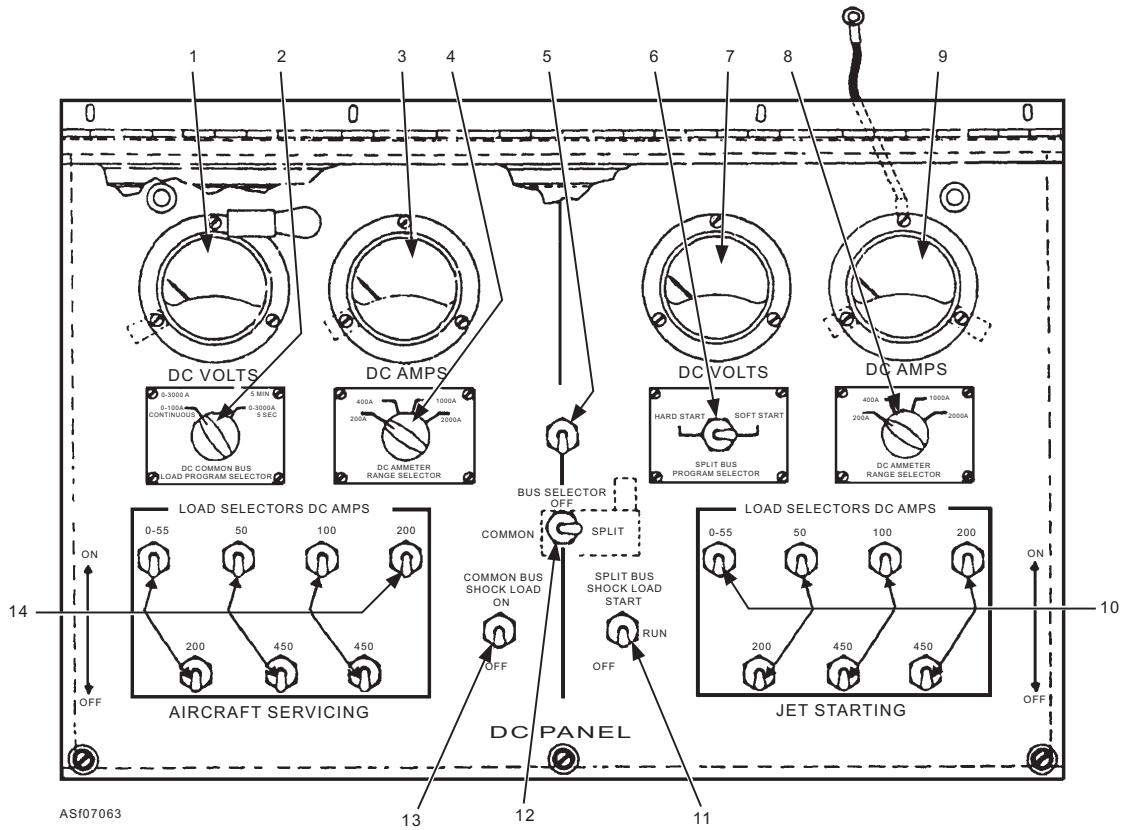

Figure 7-63.—DC control panel.

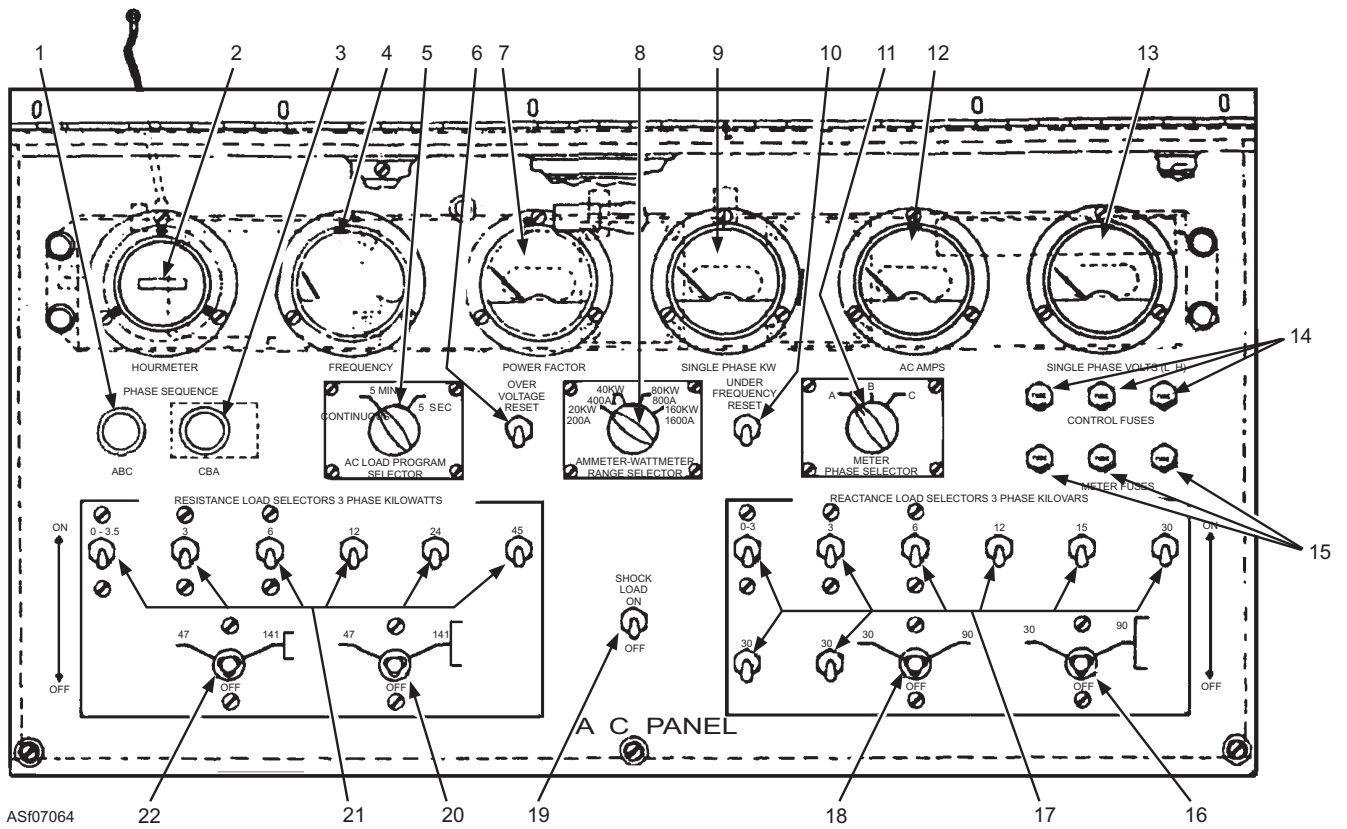

Figure 7-64.—AC control panel.

Table 7-6.—Controls and Indicators for the master Control Panel

No.	NOMENCLATURE	DESCRIPTION	FUNCTION
1	VARIABLE 0-55 AMPS	Variable carbon-pile resistor	Controls variable load applied to aircraft servicing bus from 0-55 A. Operates in conjunction with AIRCRAFT SERVICING LOAD SELECTOR DC AMPS toggle switch 0-55 on the dc control panel (fig. 7-64).
2	INTENSITY	Variable resistor	Controls intensity of dc control panel lights and dc cable input lights.
3	DC PANEL LIGHTS	2-position toggle switch	Controls dc control panel lights, dc cable input lights, and placard lights.
4	VARIABLE 0-55 AMPS	Variable carbon-pile resistor	Controls variable load applied to jet starting bus from 0 to 55 A. Operates in conjunction with JET STARTING LOAD SELECTOR DC AMPS toggle switch 0-55 on the dc control panel (fig. 7-64).
5	EXTERNAL POWER	Indicating light with red lens	Illuminates only when the CONTROL POWER switch (not shown) is ON, and the AC external power cable is fully plugged in, which provides continuity between pins E and F of the plug.
6	WIND SWITCH CLOSED	Indicating light with green lens	Illuminates when cooling fans are operating properly.
7	CONTROL CIRCUIT DC OFF AC	3-position toggle switch	In DC position, selects control circuit power directly from aircraft servicing dc input. In AC position, selects control circuit power from stepped-down and rectified ac input. In OFF position, deenergizes all control circuits.
8	VARIABLE 0-3.5 KW	Variable 3-phase autotransformer	Controls variable resistive load applied to ac input lines from 0 to 3.5 KW. Operates in conjunction with RESISTANCE LOAD SELECTORS 3 PHASE KILOWATTS toggle switch 0-3.5 on the ac control panel (fig. 7-65).
9	INTENSITY	Variable resistor	Controls intensity of ac control panel lights.
10	AC PANEL LIGHTS	2-position toggle switch	Controls ac panel lights and placard lights.
11	VARIABLE 0-3 KVAR	Variable 3-phase autotransformer	Controls variable reactive load applied to ac input lines from 0 to 3 KVAR. Operates in conjunction with REACTANCE LOAD SELECTORS 3 PHASE KILOWATTS toggle switch 0-3 on the ac control panel (fig. 7-65).
12	CIRCUIT CHECK	Cannon Plug	Provides receptacle for using an AN/USM-128 Generator Test Set to verify ac, dc, and frequency gauges.

Table 7-7.—Controls and Indicators for the DC Control Panel

No.	NOMENCLATURE	DESCRIPTION	FUNCTION
1	DC VOLTS	DC voltmeter	Indicates dc voltage at aircraft servicing input terminals and receptacles.
2	DC COMMON BUS LOAD PROGRAM SELECTOR	3-position rotary switch	Selects dc common bus loading program: continuous, 5-min timed, or 5-sec timed.
3	DC AMPS	DC ammeter	Indicates direct current loading of aircraft servicing input in four ranges as determined by DC AMMETER RANGE SELECTOR switch (4)
4	DC AMMETER RANGE SELECTOR	4-position rotary switch	Selects current range indicated by DC AMPS meter (3). Ranges are: 0 to 200A, 0 to 400A, 0-1000A, and 0 to 2000A.
5	OVERVOLTAGE RESET	Spring-loaded, 2-position toggle switch	Manually resets dc control circuit after an overvoltage cutout.
6	SPLIT BUS PROGRAM SELECTOR	2-position toggle switch	Selects split load bus operation for either hard start or soft start jet engine starting.
7	DC VOLTS	DC voltmeter	Indicates dc voltage at jet starting input terminals and receptacles.
8	DC AMMETER RANGE SELECTOR	4-position rotary switch	Selects current range indicated by DC AMPS meter (9). Ranges are: 0 to 200A, 0 to 400A, 0 to 1000A, and 0 to 2000A.
9	DC AMPS	DC AMMETER	Indicates direct current loading of jet starting input in four ranges as determined by DC AMMETER RANGE SELECTOR switch (8).
10	LOAD SELECTOR DC AMPS 0-55, 50, 100, 200, 200, 450, 450	Seven 2-position toggle switches	Apply dc resistive loads to Aircraft servicing input in common bus mode, or to jet starting input in split bus and hard start modes. Load increments are in amperes, as marked.
11	SPLIT BUS SHOCK LOAD	Spring-loaded, 3-position toggle switch	Applies split bus resistive load to jet starting input for time intervals determined by SPLIT BUS PROGRAM SELECTOR switch (6). Momentary START position initiates timed test. OFF position aborts timed test.
12	BUS SELECTOR	3-position toggle switch	Selects either common bus or split bus dc loading configuration. OFF position disables all dc loading.
13	COMMON BUS SHOCK LOAD	2-position toggle switch	Applies common bus resistive load to aircraft servicing input for continuous or timed intervals determined by DC COMMON BUS LOAD PROGRAM SELECTOR switch (2). ON position initiates timed test. OFF position aborts timed test.
14	LOAD SELECTORS DC AMPS 0-55, 50, 100, 200, 200, 450, 450	Seven 2-position toggle switches	Apply dc resistive loads to aircraft servicing input in either common bus or split bus mode. Load increments are in amperes, as marked.

Table 7-8.—Controls and Indicators for the AC Control Panel

No.	NOMENCLATURE	DESCRIPTION	FUNCTION
1	PHASE SEQUENCE ABC	Indicating light with white lens	Glows brightly if phase sequence of ac input is A to B to C.
2	HOUR METER	Elapsed time totalizing counter	Indicates accumulated time during which control power is active in load bank.
3	PHASE SEQUENCE CBA	Indicating light with white lens	Glows brightly if phase sequence of ac input is C to B to A.
4	FREQUENCY	Frequency meter	Indicates frequency of ac input.
5	AC LOAD PROGRAM SELECTOR	3-position rotary switch	Selects ac loading program: continuous, 5-min timed, or 5-sec timed.
6	OVERVOLTAGE RESET	Spring-loaded, 2-position toggle switch	Manually resets control circuits and ac loading circuits after an ac overvoltage cutout, provided that phase A to neutral voltage is 125 V or less.
7	POWER FACTOR	Power factor meter	Indicates power factor of applied load in phase determined by METER PHASE SELECTOR switch.
8	AMMETER-WATTMETER RANGE SELECTOR	4-position rotary switch	Selects current range indicated by AC AMPS meter and power range indicated by SINGLE PHASE KW meter. Ranges are: <ul style="list-style-type: none"> • 0 to 200A and 0 to 20 KW, • 0 to 400A and 0 to 40 KW, • 0 to 800A and 0 to 80 KW, • 0 to 1600A and 0 to 160 KW.
9	SINGLE PHASE KW	AC wattmeter	Indicates single phase wattage of ac load applied to phase selected by METER PHASE SELECTOR switch in four ranges as determined by AMMETER-WATTMETER RANGE SELECTOR switch.
10	UNDERFREQUENCY RESET	Spring-loaded, 2-position toggle switch	Manually resets control circuit and ac loading circuit after an underfrequency cutout, provided that phase A frequency is 377 Hz or greater.
11	METER PHASE SELECTOR	3-position rotary switch	Selects phase of ac input for indication by all meters on ac control panel except HOURMETER.
12	AC AMPS	AC ammeter	Indicates ac loading of ac input phase selected by METER PHASE SELECTOR switch in four ranges as determined by AMMETER-WATTMETER RANGE SELECTOR switch.
13	SINGLE PHASE VOLTS (L-N)	AC voltmeter	Indicates line-to-neutral voltage of ac input phase selected by METER PHASE SELECTOR switch.
14	CONTROL FUSES	Three 10A fuses	Protect three phases of ac control circuits.
15	METER FUSES	Three 1A fuses	Protect PHASE SEQUENCE lights ABC and CBA and SINGLE PHASE VOLTS (L-N) meter.

Table 7-8.—Controls and Indicators for the AC Control Panel—Continued

No.	NOMENCLATURE	DESCRIPTION	FUNCTION
16	30 90 OFF	3-position toggle switch	In 30 position, applies continuous or timed 30 KVAR reactance load to ac input as determined by AC LOAD PROGRAM SELECTOR switch. In 90 position, applies 5-min or 5-sec timed 90 KVAR reactance load as determined by AC LOAD PROGRAM SELECTOR switch.
17	REACTANCE LOAD SELECTORS 3-PHASE KILOVARS 0-3 3 6 12 15 30 30 30	Eight 2-position toggle switches	Apply reactive loads to ac input. Load increments are in KVAR, as marked
18	30 90 OFF	3-position toggle switches	In 30 position, applies continuous or timed 30 KVAR reactance load to ac input as determined by AC LOAD PROGRAM SELECTOR switch. In 90 position, applies 5-sec timed 90 KVAR reactance load with AC LOAD PROGRAM SELECTOR switch in 5 SEC position.
19	SHOCK LOAD	2-position toggle switch	Applies resistive and reactive loads to ac input for time intervals determined by AC LOAD PROGRAM SELECTOR switch. OFF position aborts timed test.
20	47 141 OFF	3-position toggle switch	In 47 position, applies continuous or timed 47 KW resistance load to AC LOAD PROGRAM SELECTOR switch. In 141 position, applies 5-min or 5-sec timed 141 KW resistance load, as determined by AC LOAD PROGRAM SELECTOR switch.
21	RESISTANCE LOAD SELECTORS 3-PHASE KILOWATTS 0-3.5 3 6 12 24 45	Six 2-position toggle switches	Apply resistive loads to ac input. Load increments are in KW, as marked.
22	47 141 OFF	3-position toggle switch	In 47 position, applies continuous or timed 47 KW resistance load to ac input as determined by AC LOAD PROGRAM SELECTOR switch. In 141 position, applies 5-sec timed 141 KW resistance load with AC LOAD PROGRAM SELECTOR switch in 5 SEC position.

Control Power Application, DC Source

If power for operating the load bank is supplied by the 28-volt dc output of the power plant, proceed as follows:

1. Make sure that the 28-volt power cables of the power plant are connected to the aircraft servicing connection facilities on the dc input panel (2, fig. 7-61).

2. Operate the power plant to apply 28 volts to the load bank.
3. Verify that the DC VOLTS meter (1, fig. 7-63) indicates 28 volts.

NOTE: The load bank will not operate if the dc input exceeds 31 volts, nor can it be reset until the dc input is reduced below 29 volts.

4. Place the DC/AMMETER RANGE SELECTOR switches (4 and 8, fig. 7-63) in the 2000A position.
5. Place the CONTROL CIRCUIT switch (7, fig. 7-62) in the dc position. The cooling fans should start and the WIND SWITCH CLOSED indicator (6) should illuminate.
6. Turn on the dc PANEL LIGHTS toggle switch (3, fig. 7-62) and adjust INTENSITY control knob (2) for desired panel illumination level.

Control Power Application, AC Source

If power for operating the load bank is supplied by the 115/200-volt, 400-Hz, ac output of the power plant, proceed as follows:

1. Connect the 115/200-volt power cable to the ac input connection facilities on the ac input panel (3, fig. 7-61).
2. Operate the power plant to apply 115/200 volts to the load bank.
3. Set the METER PHASE SELECTOR switch (11, fig. 7-64) to each of its three positions and verify that the SINGLE PHASE VOLTS meter (13) indicates 115 volts for each phase.

NOTE: The load bank will not operate if the ac input exceeds 130 volts in phase A, nor can it be reset until the ac input is reduced below 125 volts.

4. Verify that the FREQUENCY meter (4, fig. 7-64) indicates 400 Hz.

NOTE: The load bank will not operate if the ac input frequency is less than 370 Hz, nor can it be reset until the frequency is increased to at least 377 Hz.

5. Note the bright illumination of either the PHASE SEQUENCE ABC indicator (1, fig. 7-64) or the PHASE SEQUENCE CBA indicator (3). Load bank circuits are not affected by the phase sequence of input power. Improper phase sequence may indicate the wrong cable connections or faulty operation of the power plant.
6. Place the AMMETER-WATTMETER RANGE SELECTOR switch (8, fig. 7-64) in the 1600 A position.
7. Place the CONTROL CIRCUIT switch (7, fig. 7-62) in the ac position. The cooling fans should start, and the WIND SWITCH CLOSED

indicator (6) and EXTERNAL POWER indicator (5) should illuminate.

8. Turn on the AC PANEL LIGHTS toggle switch (10, fig. 7-62), and adjust the INTENSITY control knob (9) for the desired panel illumination level.

OPERATING PROCEDURES

The load bank has the capability to test straight dc output (common bus), dc jet starting output (split bus), and ac output.

Common Bus DC Operation

To test power plants by using the aircraft servicing input of the load bank, proceed as follows:

1. Place the BUS SELECTOR switch (12, fig. 7-63) in the COMMON position.
2. Place the DC COMMON BUS LOAD PROGRAM SELECTOR switch (2, fig. 7-63), in the desired position.
 - a. In the CONTINUOUS position, a continuous load of up to 3,000 amperes can be applied for as long as the COMMON BUS SHOCK LOAD toggle switch (13) is in the ON position.
 - b. In the 5-MIN position, a load of up to 3,000 amperes can be applied when the COMMON BUS SHOCK LOAD switch is in the ON position.
 - c. The load is automatically dropped after 5 minutes. In the 5-SEC position, the load is automatically dropped after 5 seconds.
3. Select the desired load by placing the appropriate LOAD SELECTORS DC AMPS switches (10 and 14, fig. 7-63) in the ON position.
4. Place the COMMON BUS SHOCK LOAD switch (13, 7-63) in the ON position and read the DC AMPS meters (3 and 9). The actual load is the sum of the two meter indications.
 - a. If either of the meters indicates near the low end of its scale, place the corresponding DC AMMETER RANGE SELECTOR switch (4 or 8, fig. 7-63) in the position closest to, but greater than, the applied dc load.

- b. If the aircraft servicing input is providing the power for the load bank's control power circuit, the indicated load is greater than selected (approximately 40 amps greater). Change the settings of the LOAD SELECTORS DC AMPS toggle switches (10 or 14, fig. 7-63), as required, and use the VARIABLE 0-55 AMPS controls (1 and 4, fig. 7-62) if needed to obtain the desired load indications.

NOTE: The LOAD SELECTOR DC AMPS switches marked 0-55 must be in the ON position to permit operation of the VARIABLE 0-55 AMPS controls.

- c. The amount of load may be adjusted at any time by operating the LOAD SELECTORS DC AMPS toggle switches (10 or 14, fig. 7-63) or the VARIABLE 0-55 AMPS controls (1 or 11, fig. 7-62).

NOTE: To ensure accurately timed programs, do not change the position of the DC COMMON BUS LOAD PROGRAM SELECTOR switch (2, fig. 7-63) unless the COMMON BUS SHOCK LOAD switch (13) is in the OFF position.

5. To stop the test and drop the load, place the COMMON BUS SHOCK LOAD switch (13) in the OFF position. If the DC COMMON BUS LOAD PROGRAM SELECTOR switch (2) is in the 5-MIN or the 5-SEC position, this action also resets the timers.

Split Bus DC Operation

If the power plant has split bus characteristics, 28 volts dc must be fed to the aircraft servicing input to operate the load bank while the jet starting voltage is fed to the jet starting input of the load bank. If the jet starting power plant does not have split bus characteristics, connect a source of 115/200 volts, three-phase, four-wire, 400-Hz power to the ac input of the load bank and place the CONTROL CIRCUIT switch (7, fig. 7-62) in the ac position. This arrangement enables the 115/200-volt power source to operate the control power circuit of the load bank while the jet starting power plant is being loaded and tested.

To test power plants by using the jet starting input of the load bank, proceed as follows:

1. Verify that the SPLIT BUS SHOCK LOAD switch (11, fig. 7-63) is in the OFF position.

2. Place the BUS SELECTOR switch (12, fig. 7-63) in the SPLIT position.
3. If load testing, the aircraft servicing input is not required while testing the power plant for jet starting performance. Skip to step 7.

4. Place the DC COMMON BUS LOAD PROGRAM SELECTOR switch (2, fig. 7-63) in the desired position.

- a. In the CONTINUOUS position, a continuous load of up to 1,500 amperes can be applied to the aircraft servicing input for as long as the COMMON BUS SHOCK LOAD switch (13) is in the ON position.

In the 5-MIN position, a load of up to 1,500 amperes can be applied when the COMMON BUS SHOCK LOAD switch (13) is in the ON position. The load is automatically dropped after 5 minutes.

- c. In the 5-SEC position, the load is automatically dropped after 5 seconds.

5. Select the desired load by placing the appropriate LOAD SELECTORS DC AMPS toggle switches (14, fig. 7-63) in the ON position.

6. Place the COMMON BUS SHOCK LOAD switch (13, fig. 7-63) in the ON position and read the DC AMPS meter (3). Place the DC AMMETER RANGE SELECTOR switch (4, fig. 7-63) in the position closest to, but greater than, the dc load applied.

- a. If the aircraft servicing input is providing the power for the load bank's control power circuit, the indicated load is greater than selected (approximately 40 amps greater). Change the settings of the LOAD SELECTORS DC AMPS switches (14, fig. 7-63), as required, and use the VARIABLE 0-55 AMPS control (1, fig. 7-62) if needed to obtain the desired load indication.

NOTE: The LOAD SELECTORS DC AMPS toggle switch marked 0-55 must be in the ON position to permit operation of the VARIABLE 0-55 AMPS control.

- b. The amount of load may be changed at any time by operating the LOAD SELECTORS DC AMPS toggle switches (14, fig. 7-63) or the VARIABLE 0-55 AMPS control (1, fig. 7-62).

NOTE: To ensure accurately timed programs, do not change the position of the DC COMMON BUS LOAD PROGRAM SELECTOR switch (2, fig. 7-63) unless the COMMON BUS SHOCK LOAD switch (13) is in the OFF position.

7. Set the SPLIT BUS PROGRAM SELECTOR switch (6, fig. 7-63) to the desired position—HARD START or SOFT START.
 - a. In the HARD START position, the desired hard start load must be selected by turning on the appropriate LOAD SELECTOR DC AMPS toggle switch (10, 7-63).
 - b. In the SOFT START position, the load is automatically selected, regardless of the switch (10) positions. Only power plants equipped with soft start characteristics (reduced voltage output for first 10 seconds of test) are tested using the soft start program.
8. Hold the SPLIT BUS SHOCK LOAD switch (11, fig. 7-63) in the START position until the DC AMPS meter (9) indicates that the load is applied, and then release the switch to the RUN position. In a hard start program, the load is dropped automatically after 20 seconds; it is maintained in an OFF position for 40 seconds, during which time the load cannot be reapplied. In a soft start program, the load is automatically selected at 1,000 amperes at 5 volts for 10 seconds, and then 200 amperes at 28 volts for 10 seconds, after which the 40-second OFF condition occurs.
 - a. Place the DC AMMETER RANGE SELECTOR switch (8, fig. 7-63) in the position closest to, but greater than, the dc load applied.
 - b. The load may be dropped at any time during the program by placing the SPLIT BUS SHOCK LOAD switch (11, 7-63) in the OFF position. However, if the load is dropped in this manner during a timed sequence, the next test cycle (normally 20 seconds) is shortened, depending upon how long the switch was in the RUN position before the load drop and how much time was allowed before the start of the next cycle. For a full reset, allow the switch to remain in the

OFF or RUN position for 60 seconds before starting another test cycle.

9. After completing the tests of the power plant, proceed as follows:
 - a. Place both SHOCK LOAD switches (11 and 13, fig. 7-63) in the OFF position.
 - b. Turn the VARIABLE 0-55 AMPS controls (1 and 4, fig. 7-62) fully counterclockwise.
 - c. Disconnect the power plant from the load bank or shut down the power plant by appropriate switching as described in the power plant operating manual.

WARNING

Always make certain that the power supply to the load bank has been completely cut off (check the DC VOLT meters for indications) before disconnecting power cables.

AC Operation

To test the 115/200 volts, three-phase, four-wire, 400-Hz output of a power plant, proceed as follows:

1. Place the AC LOAD PROGRAM SELECTOR switch (5, fig. 7-64) in the desired position.
 - a. In the CONTINUOUS position, a continuous load of up to 187.5 KVA, at any power factor between 1.0 and 0.2, can be applied for as long as the SHOCK LOAD SWITCH (19, fig. 7-64) is in the ON position.
 - b. In the 5-MIN position, a load of up to 281.5 KVA, at any power factor between 1.0 and 0.47, can be applied when the SHOCK LOAD switch (19) is placed in the ON position. The load is dropped automatically after 5 minutes.
 - c. In the 5-SEC position, a load of up to 375.5 KVA, at any power factor between 1.0 and 0.57, can be applied when the SHOCK LOAD switch (19) is placed in the ON position. The load is dropped automatically after 5 seconds.
2. From the required KVA and PF (power factor) load specifications for the power plant to be tested, calculate the following corresponding

component factors: total (three-phase) KW, single-phase KW, total KVAR, and single-phase amperes (I_1), from the formulas below or by referring to the chart in figure 7-65, (to obtain approximate values for total KW and total KVAR).

$$\begin{aligned} \text{total KW} &= \text{KVA} \times \text{PF} \\ \text{single-phase KW} &= \frac{\text{total KW}}{3} \\ \text{total KVAR} &= \text{KVA} \times \sqrt{1 - (\text{PF})^2} \\ I_1 &= \frac{\text{KVA} \times 1,000}{3V} \end{aligned}$$

where V is the voltage indicated by the SINGLE-PHASE VOLTS (L-N) meter (13, fig. 7-64).

3. Select the calculated total resistive load in KW by placing the appropriate RESISTANCE LOAD SELECTORS 3 PHASE KILOWATTS toggle switches (20, 21, and 22, fig. 7-64) in the ON position.
4. Select the calculated reactive load in KVAR by placing the appropriate REACTANCE LOAD SELECTORS 3-PHASE KILOVARS toggle switches (16, 17, and 18, fig. 7-64) in the ON position.
5. Place the SHOCK LOAD switch (19, fig. 7-64) in the ON position and read the following meters: POWER FACTOR meter (7, fig. 7-64), SINGLE-PHASE KW meter (9), and AC AMPS meter (12) to verify that the required load is being applied.

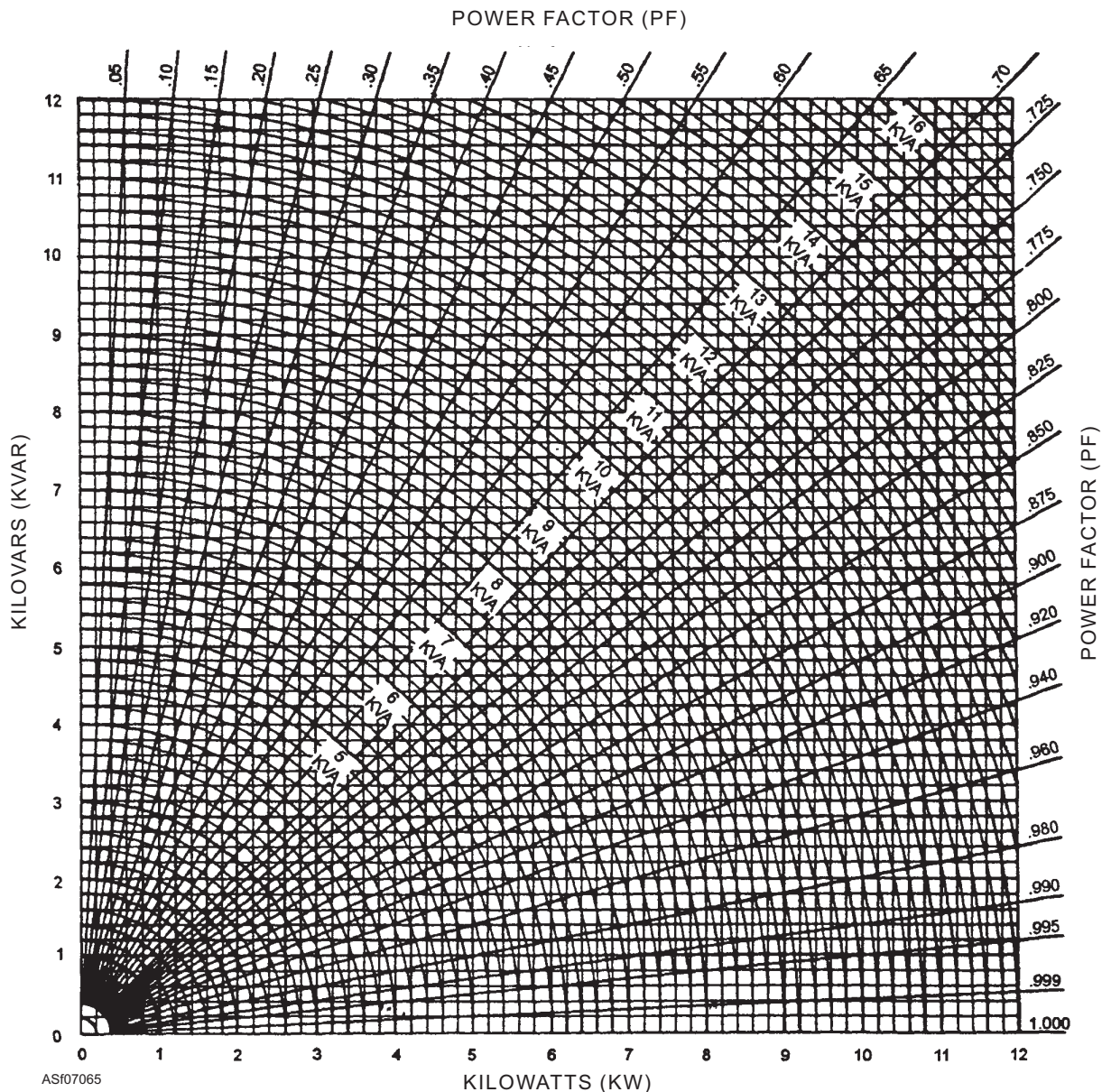

Figure 7-65.—Kilowatts (KW) chart.

- a. If the SINGLE-PHASE KW meter (9) and the AC AMPS meter (12) indicate near the low end of their scales, place the AMMETER-WATTMETER RANGE SELECTOR switch (8) in the position closest to, but greater than, the load factor applied.

NOTE: The RESISTANCE LOAD SELECTORS 3-PHASE KILOWATT toggle switch marked 0-3.5 must be in the ON position to permit operation of the VARIABLE 0-3.5 KW control (8, fig. 7-62), and the REACTANCE LOAD SELECTOR 3-PHASE KILOVAR toggle switch marked 0-3 must be in the ON position to permit operation of the VARIABLE 0-3 KVAR control (11, fig. 7-62).

- b. If the ac input is providing the power for the load bank's control circuits, the indicated load is greater than selected (approximately 13 amperes per phase greater). Change the settings of the LOAD SELECTOR toggle switches (21) as required. Use the VARIABLE 0-3.5 KW and VARIABLE 0-3 KVAR controls (8 and 11, fig. 7-62) if needed to obtain the desired load indications. Adjust the resistance loading controls first to obtain the required single-phase KW indication, then adjust the reactance loading controls to obtain the required power factor and amperage indications.
- c. The amount of KW or KVAR load may be changed at any time by operating the RESISTANCE LOAD SELECTOR switch (21) or the REACTANCE LOAD SELECTOR switches (17) or the VARIABLE controls.

NOTE: To ensure accurately timed programs, do not change the position of the AC LOAD PROGRAM SELECTOR switch (5) unless the SHOCK LOAD switch (19) is in the OFF position.

- d. Operation of these controls influences the indications of the POWER FACTOR meter (7), the SINGLE-PHASE KW meter (9), and the AC AMPS meter (12). To obtain the total KVA value, multiply the AC AMPS meter reading times the SINGLE-PHASE VOLTS (L-N) meter (13) reading with the AMMETER-WATTMETER RANGE SELECTOR switch (8) placed in each of the three positions. Then, add the three products and divide the sum by 1,000.

6. Place the COMMON BUS SHOCK LOAD switch (13, fig. 7-63) in the OFF position to stop the test and drop the load. This action also resets the timers if the AC LOAD PROGRAM SELECTOR switch (5) is in the 5-MIN or the 5-SEC position.
7. After completing the tests of the power plant, proceed as follows:
 - a. Place the SHOCK LOAD switch (19) in the OFF position.

WARNING

Always make certain that the power supply to the load bank has been completely cut off (check the AC-VOLT meter for indications in all three phases) before disconnecting the power cables.

- b. Disconnect the power plant from the load bank or shut down the power plant by appropriate switching, as described in the power plant operating manual.

Normal Shutdown Procedure

After all power plant tests have been completed, proceed as follows:

1. Place all toggle switches except the CONTROL CIRCUIT toggle switch (7, fig. 7-62) in the OFF position.
2. Place the DC AMMETER RANGE SELECTOR switches (4 and 8, fig. 7-63) in the 2000 A position.
3. Place the AMMETER-WATTMETER RANGE SELECTOR switch (8, fig. 7-64) in the 160 KW/1600 A position.
4. Place the DC COMMON BUS LOAD PROGRAM SELECTOR switch (2, fig. 7-63) and the AC LOAD PROGRAM SELECTOR switch (5, fig. 7-64) in the CONTINUOUS position.
5. Make certain that the VARIABLE 0-55 AMPS controls (1 and 4, fig. 7-62) are turned fully counterclockwise.
6. Allow the fans to operate for 5 minutes to dissipate internal heat from the load bank.
7. Place the CONTROL CIRCUIT switch (7, fig. 7-62) in the OFF position.

8. Shut down the power plant(s) connected to the load bank, then disconnect all cables.

WARNING

Always make certain that the power supply to the load bank has been completely shut off (check the DC-VOLT and AC-VOLT meters for indications) before disconnecting the power cables.

9. Close and secure all covers and doors on the load bank.

Emergency Shutdown Procedure

To shut down the load bank in an emergency, proceed as follows:

1. Place the CONTROL CIRCUIT switch (7, fig. 7-62) in the OFF position. This action drops all loads and turns off the control power circuit in the load bank.
2. Place all toggle switches on all control panels to the OFF position.
3. Turn the VARIABLE 0-55 AMPS controls (1 and 4, fig. 7-62) fully counterclockwise.

CAUTION

This course is intended only to familiarize you with equipment operation. Because of support equipment changes and manufacturer's updates, proper procedures may change. Always consult the technical manual for proper operating procedures. Operating procedures for both the MLB1 and the DA-675/MSM are also attached to the inside cover of the control panels.

FAILURE OF THE LOAD BANK TO OPERATE

The following text provides guidance for the operator in situations where the load bank cannot be started or ceases to operate during a power plant test procedure.

DC Overvoltage Cutout

If the dc-volt voltage applied to the aircraft servicing input from the power plant exceed 31 volts, a cutout relay interrupts and locks out the dc control

power circuit in the load bank. If the CONTROL CIRCUIT toggle switch (7, fig. 7-63) is in the dc position, all dc loads are dropped. The OVER-VOLTAGE RESET toggle switch (5) on the dc panel will not reset the control power control unless the input voltage is less than 29 volts.

AC Overvoltage Cutout

If the ac voltage applied to the ac input from the power plant exceeds 130 volts (phase A to neutral), a cutout relay interrupts and locks out the ac control power circuit in the load bank. If the CONTROL CIRCUIT toggle switch (7, fig. 7-62) is in the ac position, the ac load is dropped. The OVER-VOLTAGE RESET toggle switch (6) on the ac panel does not reset the control power circuit unless the input voltage is less than 125 volts.

Underfrequency Cutout

If the frequency of the ac input from the power plant is less than 370 Hz, a cutout relay interrupts and locks out the ac control power circuit in the load bank. If the CONTROL CIRCUIT toggle switch (7, fig. 7-62) is in the ac position, the ac load is dropped. The UNDERFREQUENCY RESET toggle switch (10) on the ac panel does not reset the control power circuit unless the frequency is greater than 377 Hz.

Cooling Airflow Failure

Two wind switches in the load bank sense the flow of cooling air through the load bank assemblies. If this flow of air is reduced by obstructions, such as blockage of inlet louvers or closed exhaust doors, or a fan malfunctions, the wind switches extinguish the WIND SWITCH CLOSED indicator (6, fig. 7-62) and cut out the control power circuit, thereby dropping all loads. The fans continue to operate, however, unless there is a defect in one or both.

Thermal Overload

Four temperature-sensitive switches in the load bank sense the temperature in the load bank assemblies. If the temperature becomes excessively high, these switches cut out the control power circuit, thereby dropping all loads. The fans, meanwhile, will continue to operate. When the temperature drops to normal, the switches automatically reset, restoring control power.

Load Program Selector Switches

If neither the DC COMMON BUS LOAD PROGRAM SELECTOR switch (2, fig. 7-63) nor the AC LOAD PROGRAM SELECTOR switch (5, fig. 7-64) is in the CONTINUOUS position, the control circuit does not permit loads to be applied to either the dc or ac load sections of the load bank. Timed loading tests (5 minutes or 5 seconds) cannot be run simultaneously in both the ac and dc sections.

DC Meter Range Selector Switches

When dc power applied to the aircraft servicing input is used as the power source for the control power circuit of the load bank, the DC AMMETER RANGE SELECTOR switch (4, fig. 7-63) must be placed initially in the 2000 A position to enable the LOAD SELECTOR switches by latching the relay circuit. Once the circuit is latched, the DC AMMETER RANGE SELECTOR switch can be placed in a different position for accurate indication of the load current. The DC AMMETER RANGE SELECTOR switch (8, fig. 7-63) in the jet starting circuit operates in the same manner—latching the relay circuit, when it is placed in the 2000 A position. Any malfunction that shuts down the load bank drops the latch relays. This makes it necessary to place the range selector switches in the 2000 A position once again after the malfunction is corrected.

Load Selector Toggle Switch

The 450 amp LOAD SELECTOR toggle switches (14, fig. 7-63) cannot apply 450 amp loads to the aircraft servicing input unless the DC AMMETER RANGE SELECTOR switch (4) is in the 1000 A or 2000 A position. Similarly, the 450 amp LOAD SELECTOR toggle switches (10) are inactive unless the DC AMMETER RANGE SELECTOR switch (8) is in the 1000 A or 2000 A position.

Ammeter-Wattmeter Range Selector Switch

When the ac power applied to the ac input connectors or terminals is used as the power source for the control power circuit of the load bank, the AMMETER-WATTMETER RANGE SELECTOR switch (8, fig. 7-64) must be placed initially in the 160 KW/1600 A position to enable the RESISTANCE and REACTOR LOAD SELECTOR switches (21 and 17), by latching a relay circuit. Once the circuit is latched, the AMMETER-WATTMETER RANGE

SELECTOR switch can be placed in a different position for accurate indication of a single-phase load current and power (KW). Any malfunction that shuts down the load bank drops the latch relay. This makes it necessary to place the AMMETER-WATTMETER RANGE SELECTOR switch in the 160 KW/1600 A position once again after the malfunction is corrected.

ELECTRICAL SAFETY PRECAUTIONS

Under normal conditions, technicians do not work on energized circuits. But, when repairs on operating equipment must be made, the work should be done only by experienced personnel under the supervision of the senior petty officer of the work center, if possible.

When work on live circuits is necessary, every known safety precaution should be carefully observed.

- Ample light for good illumination should be provided.
- The worker should be insulated from ground with some suitable nonconducting material, such as several layers of dry canvas, dry wood, or a rubber mat of approved construction.
- The worker should, if possible, use only one hand in accomplishing the necessary repairs.
- Helpers should be stationed near the main switch or the circuit breaker so the equipment can be de-energized immediately in case of emergency.
- A person qualified in first aid for electric shock should stand by during the entire period of the repair.

High-Voltage Precautions

Personnel should never work alone near high-voltage equipment. Tools and equipment containing metal parts should not be used in any area within 4 feet of high-voltage circuits or any electric wiring having exposed surfaces. The handles of all metal tools, such as pliers and cutters, should be covered with rubber insulating tape. (The use of plastic or cambric sleeving or of friction tape alone for this purpose is prohibited.)

Before you touch a capacitor, short-circuit the terminals to make sure that the capacitor is completely discharged. Grounded shorting prods should be permanently attached to workbenches where electrical devices are regularly serviced.

Do not work on any type of electrical apparatus with wet hands or while you are wearing wet clothing. Do not wear loose or flapping clothing. The use of thin-soled shoes with metal plates or hobnails is prohibited. Wear safety shoes with nonconducting soles, if available. Do not wear flammable articles.

When working on electrical or electronic apparatus, you should first remove all rings, wristwatches, bracelets, and similar metal items. Make sure your clothing does not contain exposed zippers, metal buttons, or any type of metal fastener.

Warning signs and suitable guards should be provided to prevent personnel from coming into accidental contact with high voltages.

Low-Voltage Precautions

Most people never realize the dangers of low-voltage electric shock. These hazards are ever present; it is surprising how dangerous they can be. Defective hand tools and improper usage can be corrected, but some hazards always exist. An awareness of their existence seems to be the answer. In general beware of any voltage.

Think safety first. Working with power generating support equipment can be a very dangerous job, even if you fully understand the units. Because of the potential dangers involved, you must be extra cautious and work with another person when the units are operated. Two heads are better and safer than one.

Q7-28. Which of the following load banks is used for testing the output power of a mobile electric power plant?

1. *The UN/USM-128*
2. *The DA-675/MSM*
3. *The UT-365/USM*
4. *The DM-645/SMS*

Q7-29. Which of the following statements best describes the operation of the load bank?

1. *It is a universal, self-contained load bank that requires no external input for operation*
2. *The input power cables must be loaded separately to prevent damage to the load bank*
3. *Both ac and dc sections of the load bank may be operated individually or simultaneously without influencing each other*
4. *If the ac and dc sections are used simultaneously, they can only be loaded to half the rated capacity to prevent damage to the load bank*

Q7-30. Which of the following items is NOT a protection circuit of the load bank?

1. *DC undervoltage*
2. *Thermal overload*
3. *Cooling airflow failure*
4. *AC overvoltage*

Q7-31. Which of the following precautions is NOT a recommended safety precaution when working on a live electrical circuit?

1. *The worker should be insulated from ground*
2. *The worker should, if possible, use only one hand to accomplish the repairs*
3. *The worker should never work alone*
4. *The worker should use only USDA approved tools*

CHAPTER 8

HYDRAULIC SYSTEMS AND EQUIPMENT

INTRODUCTION

Hydraulics (also called *fluid power*) is the science of transmitting power from one place to another through the use of liquids. Within the support equipment community, this power serves many functions. Hydraulic jacks and several models of workstands operate principally by hydraulic power. The lifting and manipulating components of spotting dollies, forklifts, and weapons loaders are hydraulically operated. The brakes of self-propelled support equipment are operated hydraulically, pneumatically, or by a combination of the two. Test stands, which are used to service and test aircraft hydraulic systems, are also hydraulically operated. The maintenance of these fluid power systems and components is one of the most important responsibilities of the Aviation Support Equipment Technician (AS). As an AS, you should be able to recognize the uses and understand the operating principles of hydraulic components found in support equipment.

BASIC PRINCIPLES OF HYDRAULICS

LEARNING OBJECTIVES: Recognize the principles of hydraulic systems. Interpret hydraulic system schematics and diagrams.

This course provides a brief overview of support equipment hydraulics. You can supplement your study by taking the correspondence course, *Fluid Power*, NAVEDTRA 14105, which deals extensively with hydraulics. For more information on hydraulics, refer to the *Aviation Hydraulics Manual*, NAVAIR 01-1A-17.

BASIC CHARACTERISTICS OF LIQUIDS

Hydraulics is the science that deals with liquid pressure and liquid flow. As applied to support equipment, hydraulics is the action of liquids forced under pressure through tubing and orifices to operate various mechanisms.

As an AS, you need to understand hydraulics. To do this, you must first become familiar with some of

the characteristics of liquids. First, a liquid has no definite shape. It takes the shape of its container. This characteristic allows liquids to flow freely. When enough liquid is forced into a system, it fills all the lines and chambers open to it. Second, liquids can be only slightly compressed. Third, a liquid has the ability to transmit power.

INCOMPRESSIBILITY OF LIQUIDS

For all practical purposes, fluids are incompressible. Under extremely high pressure, the volume of a fluid can be decreased somewhat, though the decrease is so slight that it is considered to be negligible except by design engineers.

Figure 8-1 shows how this characteristic enables a liquid to transmit force. Notice how the liquid conforms to the shape of its container. In this case the container consists of two cylinders and the line that connects the cylinders. Since liquid is practically incompressible, a downward movement of piston 1 displaces fluid in cylinder 1. The fluid flows through the lines to cylinder 2. To make room for the additional fluid in cylinder 2, piston 2 will move upward.

PASCAL'S LAW

Pascal was a noted French physicist who discovered that a closed container of fluid could be used to transfer force from one place to another or to multiply force by its transmission through a fluid. Pascal's law may be stated as follows:

“Pressure applied to an enclosed or confined fluid is transmitted equally in all directions without loss and acts with equal force on equal surfaces.”

Stated another way, pressure applied anywhere on a confined fluid is transmitted undiminished in every direction. The force thus exerted by the confined fluid acts at right angles to every portion of the surface of the container, and is equal upon equal areas.

You should note that Pascal's law applies to fluids—both gas and liquid. It is the principle underlying Pascal's law that makes possible today's hydraulic systems.

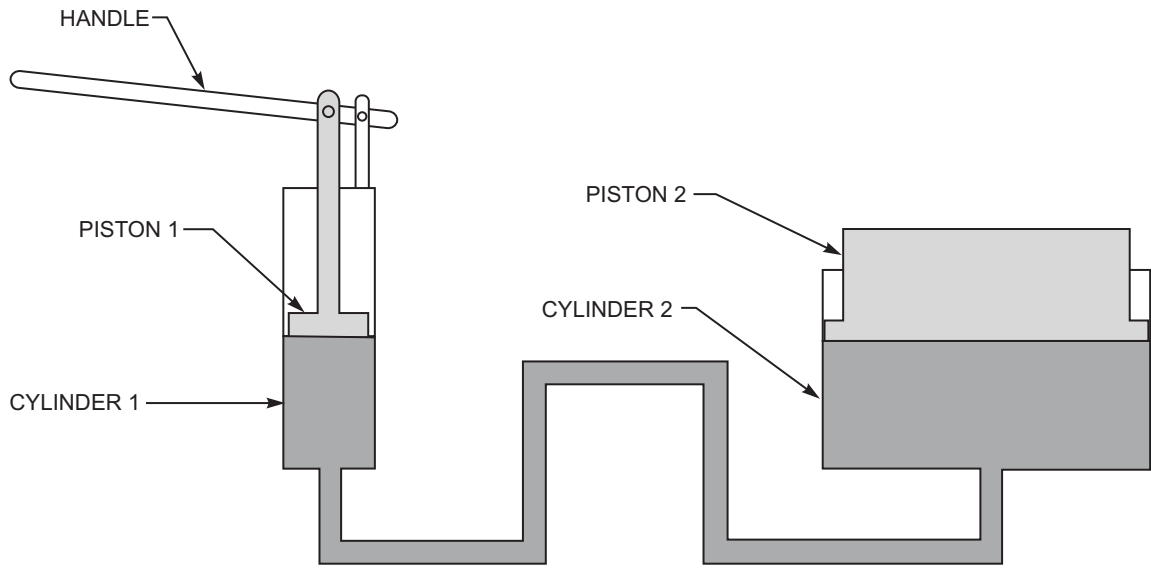
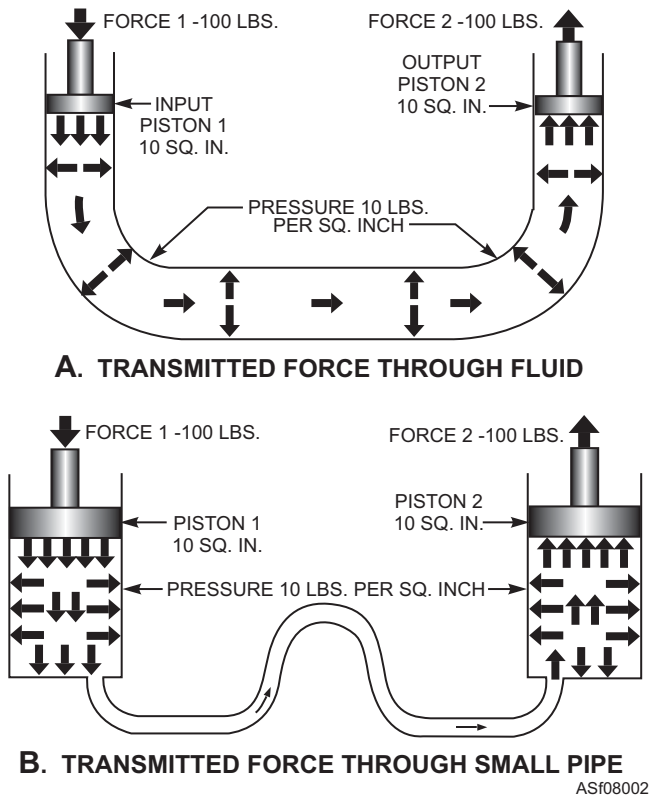

Figure 8-1.—Transmission of force by liquids.

ASF08001

By Pascal's law, any force applied to a confined fluid is transmitted in all directions throughout the fluid regardless of the shape of the container. Consider the effect of this in the systems shown in views A and B of figure 8-2. In view A, if there is resistance on the output piston (2) and the input piston (1) is pushed downward, a pressure is created through the fluid, which acts equally at right angles to surfaces in all parts of the container.

If force 1 is 100 pounds and the area of piston 1 is 10 square inches (in.²), then the pressure in the fluid is 10 pounds per square inch (psi) (100 lb ÷ 10 in.²). Take note that the fluid pressure cannot be created without resistance to flow, which in this case is provided by the 100-lb force acting against the top of piston 2. This pressure acts on piston 2 in such a way that for each square inch of its area, it is pushed upward with a force of 10 pounds. In this particular case, a fluid column of uniform cross section is shown so that the area of piston 2 is the same as that of piston 1. Therefore, the upward force on piston 2 is 100 pounds, the same as that applied to piston 1. All that has been accomplished in this system is to transmit the 100-pound force around a bend. However, this principle underlies practically all mechanical applications of fluid power.



A. TRANSMITTED FORCE THROUGH FLUID

B. TRANSMITTED FORCE THROUGH SMALL PIPE

ASF08002

Figure 8-2.—Force transmitted from piston to piston.

At this point you should note again that it is not necessary for the tube connecting the two pistons to be the full area of the pistons. A connection of any size, shape, or length will do, as long as an unobstructed passage is provided. Therefore, the system shown in view B of figure 8-2 in which a relatively small, bent pipe connects two cylinders will act exactly the same as the system shown in view A.

Multiplication of Forces

In figure 8-2, views A and B, the systems contain pistons of equal area wherein the output force is equal to the input force. Consider the situation in figure 8-3, where the input piston is much smaller than the output piston. Assume that the area of piston 1 is 2 square inches. With a resistant force on piston 2, a downward force of 20 pounds acting on piston 1

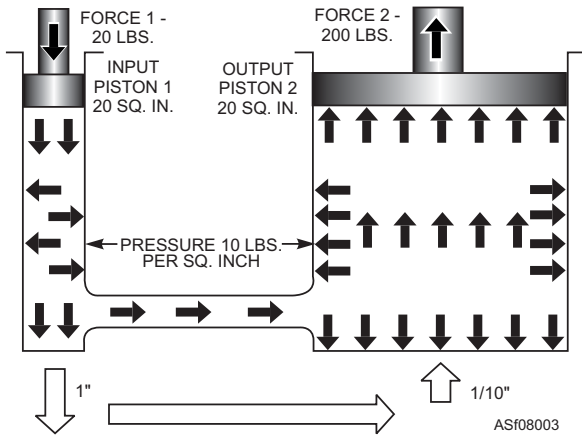

Figure 8-3.—Multiplication of forces.

creates 10 psi ($20 \text{ lb} \div 2 \text{ in.}^2$) in the fluid. Although this applied force is much smaller than the applied force shown in figure 8-2, the pressure is the same because the force is concentrated on a relatively small area.

This pressure of 10 psi acts on all parts of the fluid container, including the bottom of piston 2. Therefore, the upward force on piston 2 is 10 pounds for each of its 20 square inches of area, or 200 psi ($10 \text{ lb} \times 20 \text{ in.}^2$). In this case, the original force has been multiplied tenfold using the same pressure in the fluid as before. In any system with these dimensions, the ratio of output force to input force is always 10 to 1, regardless of the value of the applied force. For example, if the applied force of piston 1 is 50 pounds, the pressure in the system is increased to 25 psi. This will support a resistant force of 500 lb on piston 2.

The system works the same way in reverse. In figure 8-3, consider piston 2 as the input and piston 1 as the output. In that case, the output force will be one-tenth the input force. Sometimes such results are desired.

Volume and Distance Factors

In the systems shown in views A and B of figure 8-2, the pistons have areas of 10 square inches. Since the areas of the input and output pistons are equal, a force of 100 pounds on the input piston will support a resistant force of 100 pounds on the output piston. At this point the pressure of the fluid is 10 psi. A slight force in excess of 100 pounds on the input piston, however, will slightly increase the pressure of the fluid. This will work to overcome the resistance force.

Assume that the increase in pressure forces the input piston downward 1 inch. This results in the displacement of 10 cubic inches (in.^3) of fluid ($1 \text{ in.} \times$

$10 \text{ in.}^2 = 10 \text{ in.}^3$). Since liquid is practically incompressible, it must go somewhere. What happens is that the displaced fluid moves the output piston upward. Since the area of the output piston is also 10 square inches, the piston moves 1 inch upward to accommodate the 10 cubic inches of fluid. The pistons are of equal areas, so they will move equal distances, though in opposite directions.

If you apply this reasoning to the system shown in figure 8-3, and if piston 1 is pushed down 1 inch, only 2 cubic inches of fluid is displaced ($1 \text{ in.} \times 2 \text{ in.}^2 = 2 \text{ in.}^3$). To accommodate these 2 cubic inches of fluid, piston 2 will have to move only one-tenth of an inch, because its area is 10 times that of piston 1. This leads to the second basic rule for two pistons in the same fluid power system, which is the distances moved are inversely proportional to their areas.

To understand how Pascal's law is applied to hydraulics, you must make a distinction between the terms *force* and *pressure*. Force may be defined as the push or pull exerted against the total area of a particular surface and is expressed in pounds. In figure 8-3, the force exerted on piston 1 is 20 pounds. Pressure, on the other hand, is the amount of push or pull on a unit area of the surface acted upon. In hydraulics, the unit area used is the square inch, and pressure is expressed in pounds per square inch (psi). In figure 8-3, 20 pounds is exerted on 2 square inches, so pressure is 10 psi ($20 \text{ lb} \div 2 \text{ in.}^2$). It is important for you to remember that "pressure is the amount of force acting upon 1 square inch of area."

In figure 8-3, the effort exerted on piston 1 and the work accomplished by piston 2 are indicated in pounds, and they are both referred to as force. Since the confined liquid that transmits this force acts on all sides of the container, the result of these forces is indicated in pounds per square inch, or pressure.

To show the relationship among force, pressure, and area, use the formula $F = PA$. F represents force (in pounds), P represents pressure (in pounds per square inch), and A represents area (in square inches). When any two of these factors are known, you can use this formula to find the unknown.

To find force, use $F = PA$

To find pressure, use $P = \frac{F}{A}$

To find area, use $A = \frac{F}{P}$

You might compare this to the way you manipulate Ohm's law to find voltage, current, and resistance. Now, we use this formula to confirm the size of the pressure developed by piston 1 in the system shown in figure 8-3.

To find pressure, insert the known values of force (20 lb) and area (2 in.²) into the formula $F = PA$. Transposing the formula, we have:

$$P = \frac{F}{A}, \text{ or } P = \frac{20 \text{ lb}}{2 \text{ in.}^2} = 10 \text{ psi}$$

This pressure is applied to the confined liquid and, in turn, to all sides of the container, including the 20-square-inch area of piston 2. Note that the upward force exerted by the liquid on piston 2 ($F = 10 \text{ psi} \times 20 \text{ in.}^2 = 200 \text{ lb}$) is the same as the downward force (200 lb) exerted by the piston. Thus, the 20-pound force applied to piston 1 supports a force of 200 pounds acting against piston 2.

You should remember that the force exerted on piston 1 (20 lb) only creates a flow of liquid. and that the resistance force (200 lb) is required to create pressure. With no resistance against piston 2, any force exerted on piston 1 will develop only that pressure resulting from the friction of liquid flow and the weight of piston 2.

For a more realistic application of multiplication of forces, consider the 10-ton hydraulic jack system shown in figure 8-4. Assume that piston 2 is the lifting piston, with an area of 10 square inches, and that piston 1 is the pump, with an area of 0.25 square inch. Next, assume that a 10-ton (20,000 pounds) load is placed on piston 2. To support this force, a pressure of 2,000 psi must be exerted against the bottom of piston 2.

$$P = \frac{F}{A}, \text{ or } P = \frac{20,000 \text{ lb}}{10 \text{ in.}^2} = 2,000 \text{ psi}$$

To generate the 2,000 psi needed to balance the 10-ton load, a force of 500 pounds must be applied to the top of piston 1.

$$F = PA, \text{ or } F = 2,000 \text{ psi} \times 0.25 \text{ in.}^2 = 500 \text{ lb}$$

The 500 pounds of force applied to piston 1 will equal the resistant pressure of 2,000 psi and support or balance the load. To lift the load, however, requires something in excess of 500 pounds of force. Application of the force can be mechanical, such as by the lever shown in figure 8-4, or by motor, or by any other means that will generate the force required by the system. For complete and detailed descriptions of the classes of levers, consult *Basic Machines*, NAVEDTRA 14037.

Q8-1. Which of the following is NOT a characteristic of a liquid?

1. A liquid can only be slightly compressed
2. A liquid has no definite shape
3. A liquid has the ability to transmit power
4. A liquid can be compressed to half of its original volume

Q8-2. Which of the following laws state that, "pressure applied to an enclosed or confined fluid is transmitted equally in all directions without loss and acts with equal force on equal surfaces"?

1. Boyle's law
2. Pascal's law
3. Stanton's law
4. Ohm's law

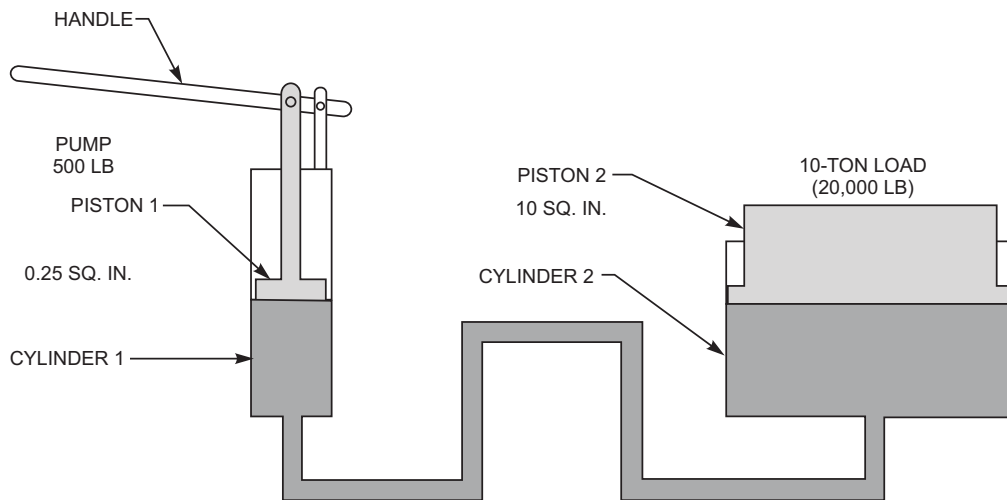

Figure 8-4.—A 10-ton hydraulic jack.

AS108004

COMPONENTS OF HYDRAULIC SYSTEMS

LEARNING OBJECTIVES: Identify the components of hydraulic systems.

Since fluids are capable of transmitting force and at the same time flow easily, the force applied to the fluid at one point is transmitted to any point the fluid reaches. Hydraulic systems are assemblies of units capable of doing this. They contain a unit for generating force (pumps), suitable tubing and hoses for containing and transmitting the fluid under pressure, and units in which the energy in the fluid is converted to mechanical work (cylinders and fluid motors). In addition, all operative systems contain valves and restrictors to control and direct the flow of fluid and limit the maximum pressure in the system.

Although the system illustrated in figure 8-1 demonstrates the fundamental principles of fluid power, several additional components are required for a complete, workable, fluid power system. For example, the basic hydraulic system requires a reservoir, a pump, a control or selector valve, an actuator, and tubing or flexible hose to connect these components. Most fluid power systems contain one or more additional components, such as pressure-relief (safety) valves, filters, accumulators, and pressure gauges.

Maintenance of fluid power systems includes troubleshooting to locate and determine the causes of malfunctions. To locate the causes of malfunctions, you must understand how the system operates. And to understand system operation, you must know the functions and the interrelationships among the components that make up the system.

Fluid Power, NAVEDTRA 14105, contains information concerning the purpose and operation of fluid power components in general. Since the material in the following text covers representative components used in the fluid power systems of support equipment, this information is intended to supplement, rather than repeat, the information given in *Fluid Power*. Therefore, you should study the applicable chapter of *Fluid Power* in conjunction with the following text.

RESERVOIRS

Each fluid power system requires a source of fluid supply. The reservoir, sometimes referred to as a tank, serves as a source of fluid supply in a hydraulic system. In addition, the reservoir serves to dissipate heat, trap

foreign particles, and separate air from the fluid. The size and the design of a hydraulic reservoir depend upon the hydraulic system. For example, the reservoir for an automatic transmission also serves as a housing for the assembly. In most hydraulic brake systems, the reservoir and master cylinder, although two separate units, are physically contained in one housing. In common hydraulic jacks and workstands, the reservoir serves as a housing for the pump and other components. However, in most hydraulic systems, the reservoir is a separate component. Figure 8-5 is a typical reservoir. The housing is normally constructed of heavy gauge metal and welded at the seams.

The functionality of the hydraulic system determines the size of the reservoir; however, the shape may sometimes be designed to fit into some convenient location in the equipment. Inspection plates are generally installed on the top of the reservoir to provide easy access for cleaning. A plug or valve is located at the lowest point in the bottom of the reservoir to provide a means for draining.

A hydraulic reservoir requires a means of equalizing the air pressure in the top of the reservoir and the surrounding atmospheric pressure. This is accomplished by incorporating an air breather in the top of the reservoir. The breather may be a separate unit as in figure 8-5, or it may be part of the filler cap. The breather normally includes an air filter. The filler neck usually contains a strainer filter.

A space is provided above the required fluid level in a reservoir to allow for thermal expansion of the fluid. This space also allows fluid to foam and air to purge from the fluid.

Some method must be provided to check the fluid level in the reservoir. Some reservoirs are provided with a sight gauge as shown in figure 8-5, or a mechanical gauge on the side of the reservoir. In others, the filler neck is recessed into the top of the reservoir. With the reservoir filled to the bottom of the filler neck, the required air space is provided.

There are two main ports in the reservoir. One serves as an outlet to supply fluid to the pump, and the other serves as an inlet for return fluid from the system. In some systems, the supply line is connected directly to the pump, and one line serves as a return line with subsystem return lines connected to it at appropriate places. Some systems are provided with manifolds in the supply and return lines. A manifold is a fluid conductor that provides multiple connection ports. The reservoir shown in figure 8-6 has a selector valve. It is a

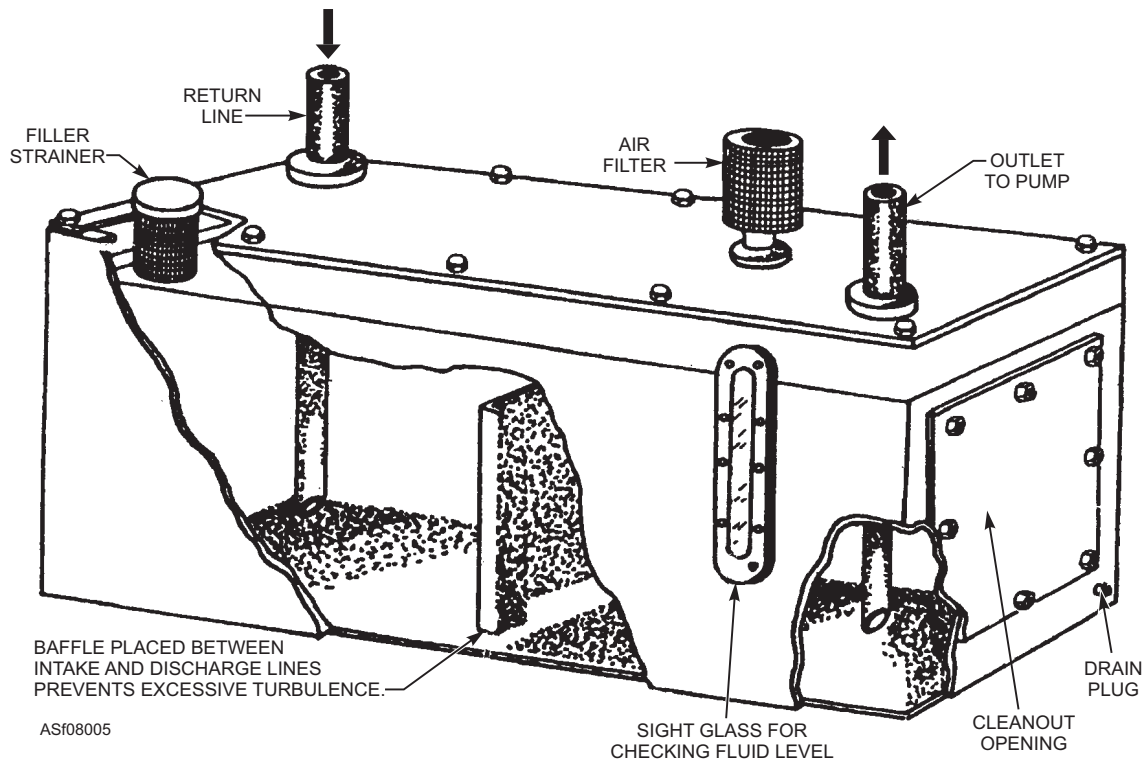

Figure 8-5.—Typical hydraulic reservoir.

four-way, two-position valve used to select either the test stand reservoir or the aircraft reservoir.

Your primary concern in servicing and maintaining hydraulic reservoirs is cleanliness. Although servicing a reservoir is a simple operation, certain procedures and precautions must be followed. Specific directions are contained in the applicable service instruction manual. In addition, some reservoirs are provided with a placard or information plate, which is located on or near the reservoir. This placard or information plate contains detailed information necessary for servicing the reservoir. This includes such information as reservoir capacity, fluid type, and caution notes.

Servicing a reservoir is accomplished by a hydraulic servicing unit or cart. Figure 8-7 illustrates the Fluid Service Cart, Model 310, a 10-gallon capacity unit. There are also 1-gallon, 3-gallon, and 55-gallon models. Each model is equipped with a 3-micron absolute filter.

HYDRAULIC PUMPS

To accomplish work, fluid power systems require some means of providing a flow of fluid. In hydraulic systems, pumps satisfy this requirement.

The heart of any hydraulic system is its pump, as it is the pump that generates the force required by the

actuating mechanisms. There are several ways to classify hydraulic pumps. One common way is by the source of power used to operate the pump. Pumps that are driven by electric motors, gasoline engines, or diesel engines are referred to as power pumps. Pumps that are manually operated are referred to as hand pumps.

Hydraulic pumps may also be classified by the type of design used to create the fluid flow. In this sense, there are three main types: centrifugal, rotary, and reciprocating. As the centrifugal style pump finds little use in support equipment, it will not be discussed here.

Terms such as *fixed displacement* and *variable displacement* are used to classify pumps. Fixed displacement pumps discharge the same volume of fluid each cycle at a given speed. Variable displacement pumps are constructed so that the volumetric output can be varied. *Fluid Power*, NAVEDTRA 14105, provides detailed information on pump classification. You should read *Fluid Power* in conjunction with the following text for a complete understanding of pump classification.

It is important that you understand what is meant by the terms *volume of output* and *pressure* in hydraulic pumps. Hydraulic pumps are normally rated in terms of their volume of output and pressure. The volume of output is the amount of fluid the pump can deliver to its

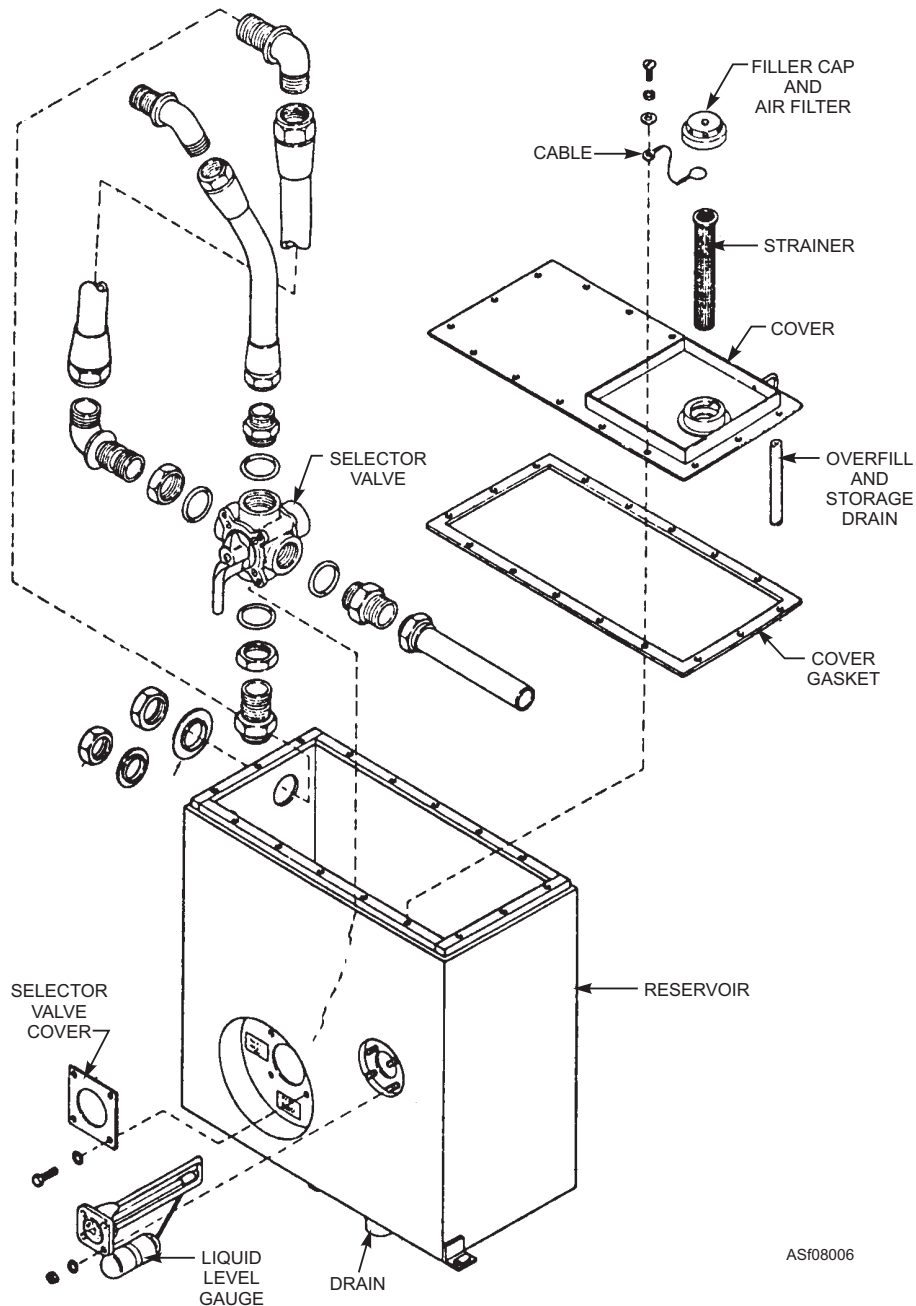

Figure 8-6.—Hydraulic Reservoir Assembly A/M27T-5.

outlet port in a given period of time at a given speed. Volume of output is usually expressed in gallons per minute (gpm). Since changes in pump speed affect the volume of output, some pumps are rated according to displacement. Pump displacement is the amount (volume) of fluid the pump can deliver per cycle. Since most pumps use a rotary drive, the displacement is at times expressed in terms of *cubic inches per revolution*.

A pump does not create pressure. However, the pressure developed by the restriction in the system is a factor that affects the volume of output of the pump. As the system pressure increases, the volume of output

decreases. This drop in the volume of output is the result of an increase in the amount of internal leakage from the outlet side to the inlet side of the pump. This leakage is called *pump slippage*, and is a factor that must be considered. For this reason, most pumps are rated in terms of volume of output at a given pressure. The amount of internal slippage in a pump is an indication of its efficiency, and is usually expressed as a percentage.

Fixed displacement pumps deliver a definite volume of fluid for each cycle of pump operation, regardless of the resistance offered. The output volume can be changed only by changing the speed of the

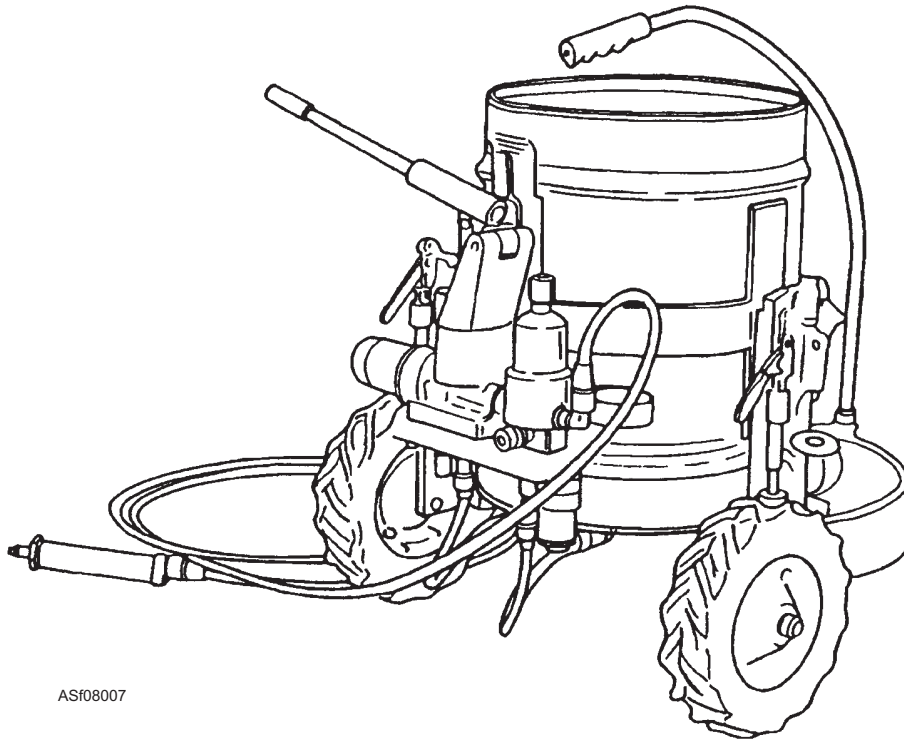

AS108007

Figure 8-7.—Fluid Service Cart, Model 310.

pump. When a fixed displacement pump is used in a hydraulic system, a pressure regulator (or unloading valve) is used to control the amount of pressure in the system. The pressure regulator also unloads or relieves the pump when the desired pressure is reached. This is to keep the pump from working against a load when the hydraulic system is at maximum pressure and not functioning. During this condition, the pressure regulator bypasses the fluid from the pump back to the reservoir. The pump, all the while, continues to deliver a fixed volume of fluid during each cycle. In this type of system you also need a relief valve to bypass pressure if the regulator or unloading valve fails.

Rotary Pumps

Rotary pumps operate by means of rotating parts that trap the fluid at the inlet (suction) port and force it through the discharge port into the hydraulic system. Gears, lobes, and vanes are commonly used as elements in rotary pumps. Rotary pumps are of the fixed displacement type.

There are many types of rotary pumps that are classified in various ways. They may be classified by shaft position (vertically or horizontally mounted); by the type of drive (electric motor, internal combustion engine, etc.); by manufacturer's name; or by service application. However, rotary pumps are usually classified by the types of rotating elements they use.

A few of the most common types of rotary pumps are discussed in the following paragraphs. All of the pumps discussed are gear pumps, so called because they use gears to trap the fluid. This style of pump is very simple in design and finds wide use in low-pressure hydraulic systems. A gear pump delivers a constant volume of fluid at any given rpm.

SPUR TOOTH PUMPS.—The gear-type rotary pump shown in figure 8-8 is called a *spur tooth pump*. It consists of two meshed gears that revolve alongside each other in one housing. The driving gear is turned by a drive shaft, which engages the power source. The clearances between the gear teeth and the pump housing are very small.

The inlet port is connected to the fluid supply line, and the outlet port is connected to the pressure line. In the pump shown in figure 8-8, the drive gear rotates counterclockwise and the driven gear rotates clockwise. As the teeth pass the inlet port, fluid is trapped between the teeth and the housing, and is carried around the housing to the outlet port. As the teeth mesh again, the liquid between the teeth is displaced into the outlet port. This action produces a positive flow of liquid into the system. A shear pin or shear section is incorporated in the drive shaft to protect the power source or reduction gears if the pump fails because of excessive load or binding of parts.

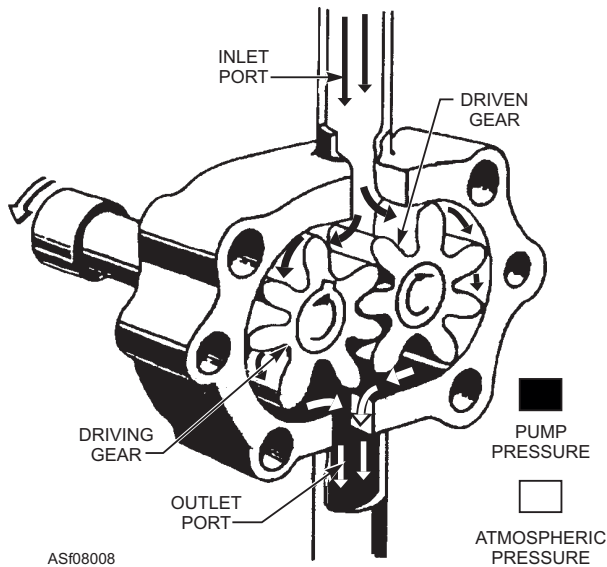

Figure 8-8.—Spur tooth pump.

Gear pumps used in support equipment hydraulic systems are normally driven by electric motors or through gearboxes by gasoline or diesel engines. Gear pumps are described in detail in *Fluid Power*, NAVEDTRA 14105.

LOBE PUMPS.—Another type of gear pump used in a variety of hydraulic systems is called a *lobe pump* (fig. 8-9). The principle of operation of this pump is exactly the same as the spur tooth pump. The lobes are constructed so there is a continuous seal (vane) at the point of juncture at the center of the pump and also on the housing.

INTERNAL GEAR PUMPS.—Another common style is the internal gear pump, shown in figure 8-10. This pump consists of a pair of gear-shaped elements (one within the other) located in the pump chamber. The inner gear is connected to the drive shaft of the source of power. In figure 8-10, you are shown both the front and the back of the mechanism. Figure 8-11 illustrates the operation of this pump.

In figure 8-11, the teeth of the inner gear and the spaces between the teeth of the outer gear are

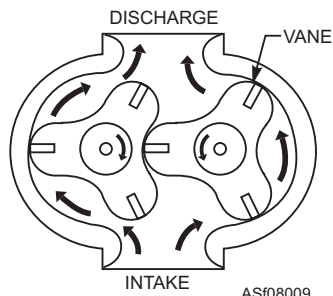

Figure 8-9.—Lobe pump.

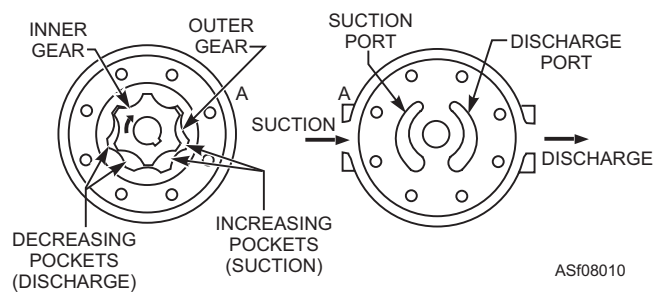

Figure 8-10.—Internal gear pump.

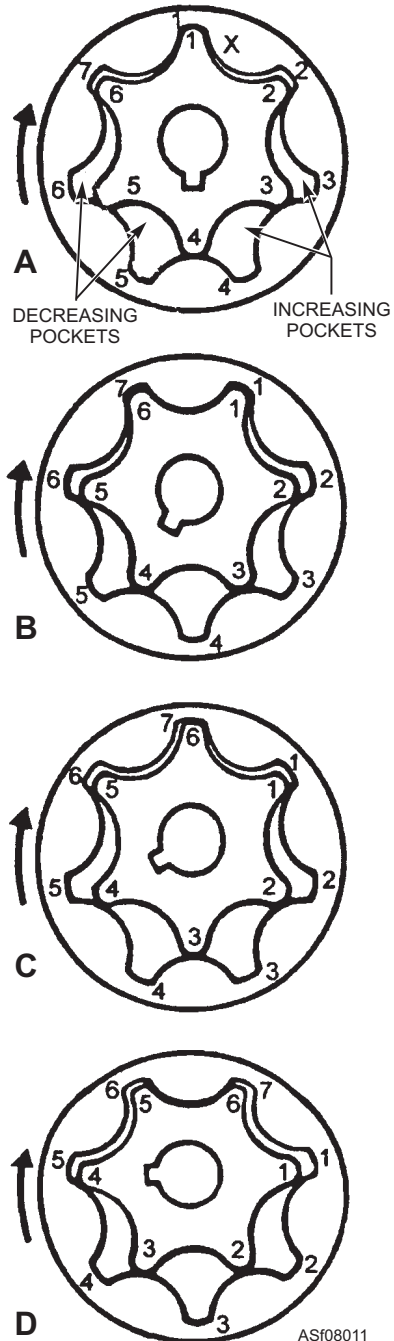

Figure 8-11.—Principles of operation of the internal gear group.

numbered. Note that the inner gear has one less tooth than the outer gear has spaces. The tooth form of each gear is related to that of the other in such a way that each tooth of the inner gear is always in sliding contact with the surface of the outer gear. Each tooth of the inner gear meshes with the outer gear at just one point during each revolution. In view A of the figure, this point is indicated by an X. In view A, tooth 1 of the inner gear is in mesh with space 1 of the outer gear. As the gears continue to rotate in clockwise direction and the teeth approach point X, tooth 6 of the inner gear will mesh with space 7 of the outer gear, tooth 5 with space 6, etc. During this revolution, tooth 1 will mesh with space 2; and in the following revolution, tooth 1 will mesh with space 3. As a result, the outer gear rotates at just six-sevenths the speed of the inner gear. For example, if the inner gear rotates at 1,400 rpm, the outer gear rotates at 1,200 rpm.

At one side of the point of mesh, pockets of increasing size are formed as the gears rotate; while on the other side, the pockets decrease in size. The pockets on the right-hand side of the drawings increase in size as you move down the illustration, while those on the left-hand side decrease in size. The motion of the gears draws fluid in on one side of the pump and pushes it out of the other side.

VANE PUMPS.—Figure 8-12 shows a vane pump of the unbalanced design. The rotor is attached to the drive shaft and is rotated by an outside power source, such as an electric motor or gasoline engine. The rotor is slotted, and each slot is fitted with a rectangular vane. These vanes, to some extent, are free to move outward in their respective slots. The rotor and vanes are enclosed in a housing, the inner surface of which is offset with the drive axis.

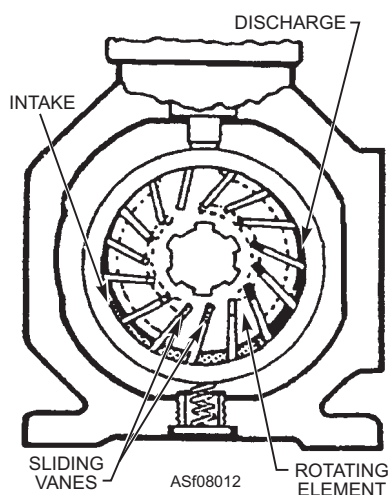

Figure 8-12.—Vane pump.

As the rotor turns, centrifugal force keeps the vanes snug against the wall of the housing. The vanes divide the area between the rotor and housing into a series of chambers. The chambers vary in size according to their respective positions around the shaft. The inlet port is located in that part of the pump where the chambers are expanding in size so that the partial vacuum (low-pressure area) formed by this expansion allows liquid to flow into the pump. The liquid is trapped between the vanes and is carried to the outlet side of the pump. The chambers contract in size on the outlet side, and this action forces the liquid through the outlet port and into the system.

The pump is called *unbalanced* because all of the pumping action takes place on one side of the shaft and rotor, causing a side load. Some vane pumps are constructed with an elliptical-shaped housing. This forms two separate pumping areas on opposite sides of the rotor, canceling out the side load. Such vane pumps are called *balanced*. Vane pumps are used extensively in power steering units in support equipment.

Reciprocating Pumps

The reciprocating pump, in one form or another, is perhaps the most common type of hydraulic pump found in support equipment. This type of pump depends upon the reciprocating (back-and-forth) motion of a piston inside a cylinder. The hand pump and the master brake cylinder are examples of reciprocating hydraulic pumps. There are also several types of power-driven reciprocating pumps, driven by a variety of motors.

Reciprocating pumps are most often used for applications requiring high pressure and accurate control of the discharge volume. There are many variations of this type of pump, which in support equipment is normally called a *piston pump*. Most of the variations, however, are based on the axial piston or hand pump principle. We will look at just a few in this chapter. (There are also radial piston pumps, but they are seldom used in support equipment.)

HAND PUMPS.—On most hydraulic systems, a hand pump is only a substitute for the support equipment's main power pump in case the power fails. However, in some support equipment, a hand pump is the only power source.

There are two major types of hand pumps—the single-action and the double-action. In a single-action pump, the fluid is drawn into the cylinder on the first (suction) stroke and forced out of the cylinder on the

return (discharge) stroke. Double-action pumps provide output flow during each stroke of the piston. Both classes of pumps are used in hydraulic systems of support equipment. For example, single-action pumps are common sources of power for hydraulic jacks and some hydraulically operated workstands. Double-action pumps are used in weapon loaders as an emergency source of hydraulic power. Double-action pumps are also used in hydraulic component test benches.

Single-Action Hand Pumps.—Two examples of single-action hand pumps are shown in figure 8-13. These pumps operate very much like piston (1) in figure 8-1. However, some means must be provided to trap fluid in the system and allow a new supply of fluid to enter the pump chamber during the return stroke. This is normally accomplished through the use of check valves (fig. 8-13). As noted earlier, pumps of this type are used in hydraulic jacks and hydraulically operated workstands.

During the UP (suction) stroke of the pump, any pressure in the line to the actuator, plus spring tension, holds the ball of the spring-loaded check valve on its seat. This traps fluid in the line to the actuator. The

relief valve also remains closed at this time. As the piston moves upward, a low-pressure area (lower than the surrounding atmosphere) is created in the lower chamber of the cylinder. At the same time, atmospheric pressure is acting on the surface of the fluid in the reservoir. This fluid, under the force of atmospheric pressure, forces the ball of the gravity check valve off its seat. Fluid then flows from the reservoir into the low-pressure area of the pump cylinder.

During the DOWN (power) stroke, the force exerted on the piston forces fluid against the gravity check valve and the spring-loaded check valve. This force immediately overcomes the force of atmospheric pressure and forces the ball of the gravity check valve off its seat. Fluid is then trapped in the lower portion of the pump cylinder, causing a resistant force against the bottom of the pump piston.

As the piston continues the DOWN stroke, the resistant force increases the pressure of the trapped fluid. The pressure increases until it overcomes the pressure of the fluid in the line to the actuator and the tension of the spring in the check valve. This forces the ball of the check valve off its seat. Fluid then flows from the pump cylinder into the line to the actuator.

The spring tension of the relief (safety) valve is adjustable. It is set to relieve at a pressure slightly above that required to overcome the maximum force that may be exerted on the actuator. For example, assume that the actuator is the ram cylinder of a 10-ton hydraulic jack, rated at 20,000 pounds. The maximum allowable load is about 10 percent above the rated load or, in this case, 22,000 pounds. Thus, the relief valve is set to relieve the pressure required to lift a load in excess of 22,000 pounds. (The rated load, maximum allowable load, relief valve setting, etc., are listed in the applicable maintenance instructions manuals.)

Assume that a load in excess of the maximum allowable load is placed on the actuator. During the DOWN stroke of the pump piston, the pressure in the system will increase to the point that it overcomes the spring tension of the relief valve. This forces the ball of the relief valve off its seat and allows fluid to flow from the pump cylinder back to the reservoir. In this way, the relief valve prevents excessive pressure buildup, which could cause damage to the system. Hence, the term *safety valve*.

Double-Action Hand Pumps.—Double-action hand pumps are used in some aircraft hydraulic systems as a source of hydraulic power for emergencies and for testing subsystems during

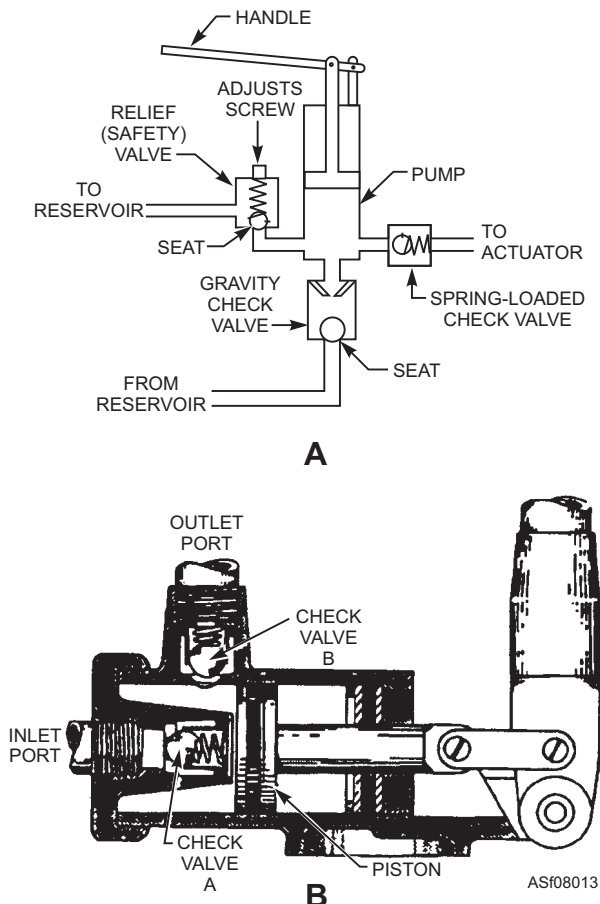

Figure 8-13.—Single-action hydraulic hand pump.

preventive maintenance inspections. Double-action pumps are also used on support equipment, such as the B-2 maintenance workstand. Figure 8-14 shows a typical double-action hand pump.

The double-action pump, shown in figure 8-14, consists of a cylinder, a piston with a built-in check valve (A), a piston rod, an operating handle, and a check valve (B) at the inlet port. When the piston is moved to the left, spring tension and the force of the liquid in the outlet chamber cause check valve A to close. This movement causes the piston to force the liquid in the outlet chamber through the outlet port and into the system. This same movement of the piston causes a low-pressure area in the inlet chamber. Atmospheric pressure acting on the liquid in the reservoir transmits this pressure to the liquid at the inlet port. The pressure differential acting on the ball of check valve B causes the spring to compress, opening the check valve. This allows liquid to enter the inlet chamber.

When the piston completes the stroke to the left, the inlet chamber is full of liquid. This liquid eliminates the low-pressure area in the inlet chamber, thereby allowing spring tension to close check valve B.

When the piston is moved to the right, the force of the confined liquid in the inlet chamber acts on the ball of check valve A. This action compresses the spring and opens check valve A, allowing the liquid to flow

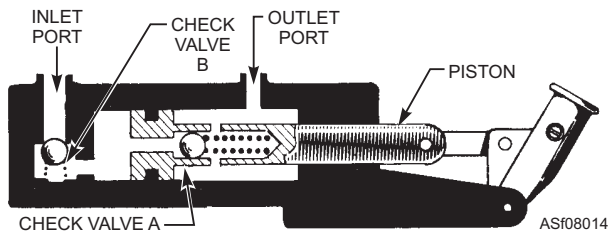

Figure 8-14.—Double-action hydraulic hand pump.

from the inlet chamber to the outlet chamber. Because of the area occupied by the piston rod, the outlet chamber cannot contain all the liquid discharged from the inlet chamber. Since the liquid will not compress, the extra liquid is forced out of the outlet port into the system, activating whatever device the pump is connected to.

Maintenance of hand pumps includes frequent pressure checks and inspections for leaks, general condition, and efficiency of operation. Operational checks and removal and replacement procedures can be found in the applicable maintenance instruction manuals.

FIXED DISPLACEMENT PISTON PUMPS.—

Fixed displacement piston pumps are a type of axial piston pump. The fixed displacement piston pump, shown in figure 8-15, produces a constant flow of fluid for any given rpm. The pistons, usually about nine, (always an odd number) are fastened by a universal linkage to a drive shaft. The universal link in the center drives the cylinder block, which is held at an angle to the drive shaft by the pump housing. Everything within the pump housing rotates with the drive shaft. As the piston is rotated to the upper position, its movement forces fluid out of the pressure port. As the same piston moves from the upper position to the lower position, it draws in fluid through the intake port. Since each piston is always somewhere between the upper and lower positions, constant intake and output of fluid results. The volume output of the pump is determined by the angle between the drive shaft and the cylinder block, as the degree of angle decreases or increases the piston stroke. The larger the angle, the greater the output per revolution.

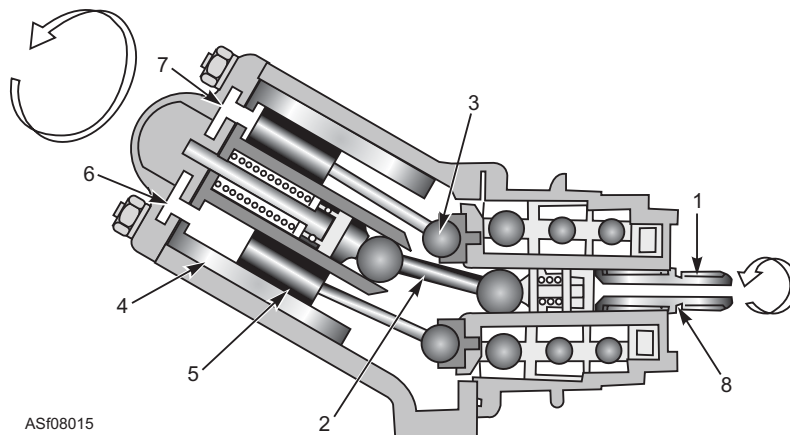

- 1. Drive shaft
- 2. Universal link

- 3. Point of attachment
- 4. Cylinder block
- 5. Piston
- 6. Intake port

- 7. Pressure port
- 8. Drive shaft seal

Figure 8-15.—Fixed displacement piston pump.

If you follow one piston through one complete revolution, you can see how the pump operates. Refer to figure 8-15, and start with the piston at the top of its cylinder. It has just completed its pressure stroke and is ready to begin its intake stroke. As the cylinder starts its rotation from this point, the piston aligns immediately with the intake port as it moves toward the bottom of the cylinder. The partial vacuum created by the movement of the piston in the cylinder and the gravity pressure (in some cases boost pressure) on the fluid cause the space above the piston to fill with fluid. When the cylinder has gone through 180 degrees (one-half revolution), the piston reaches the bottom of the cylinder, and the cylinder is full of fluid.

As rotation continues beyond this point, the piston now aligns with the outlet port slot. Thus, when the last 180 degrees have been completed, the piston will have moved forward in the cylinder, and the fluid will have been forced into the outlet line. At this point, the piston and cylinder are again ready to start another cycle.

As noted earlier, there are normally multiple pistons performing the function described above. And since the pump rotates rapidly, there is a constant flow of fluid through the outlet port. This pump normally uses case pressure and fluid flow for cooling and lubricating. Fluid seeps by the pistons in the cylinder block and fills all the space inside the pump. The fluid is prevented from escaping through the drive end of the pump by a drive shaft seal. Excessive case pressure is prevented by routing the fluid back to the inlet port of the pump through one or more relief valves. These valves are usually set at about 15 psi. This ensures circulation of fluid in the pump.

VARIABLE DISPLACEMENT PISTON PUMPS.—Variable displacement piston pumps are another type of axial piston pump, and there are many versions used in support equipment. Actually, variable displacement pumps are used more extensively than are fixed displacement pumps. Several different methods are used to vary the fluid flow through the pump. Some pumps vary the volume by controlling the inlet fluid. Some vary it by changing the angle between the pump drive shaft and the piston cylinder block. Some control volume by using a system bypass within the pump. Still others control volume by varying the piston stroke.

One advantage of the variable displacement pump is that it eliminates the need for a system pressure regulator. A second advantage is that it provides a more stable pressure. This reduces pressure surges and the need for a system accumulator, although accumulators

are normally retained for use during peak load occurrences.

The output of the fixed displacement pump is determined by pump rpm and the fixed angle between the drive shaft and the rotating cylinder block. If the angle in a fixed displacement pump could be varied, the piston stroke could be changed to vary the pump output. In fact, changing the piston stroke is the method used to vary volume on most variable displacement pumps used in support equipment. These are called *stroke reduction pumps*.

The stroke reduction pumps shown in figures 8-16 and 8-17 are fully automatic variable displacement pumps. The pressure compensating valves shown in both figures use system pressure to control and vary the pump's piston stroke, thus changing the output.

The pump piston stroke of the pump shown in figure 8-16 is determined by the angle of the cam plate. The drive shaft passes through, but does not touch, the inclined cam plate to rotate the cylinder block and pistons. The hanger assembly in the pump shown in figure 8-17 performs the same function as the cam plate in the other pump.

Variable displacement pumps may also be configured to allow manual volume control. Manual control can be achieved by using a hand wheel to vary the piston stroke, or the pump may use manual pressure compensating valves such as those used on many hydraulic test stands.

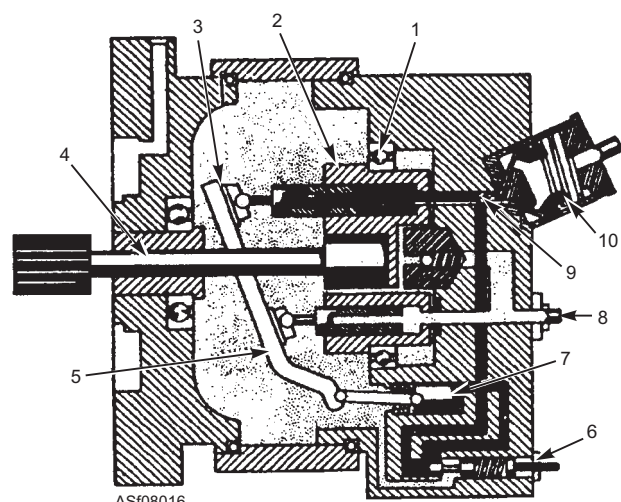

- | | |
|-----------------|----------------------|
| 1. Bearing | 6. Compensator valve |
| 2. Cylinder | 7. Stroking piston |
| 3. Piston plate | 8. Inlet |
| 4. Drive shaft | 9. Outlet |
| 5. Cam plate | 10. Check valve |

Figure 8-16.—Variable displacement, stroke reduction pump with variable cam plate.

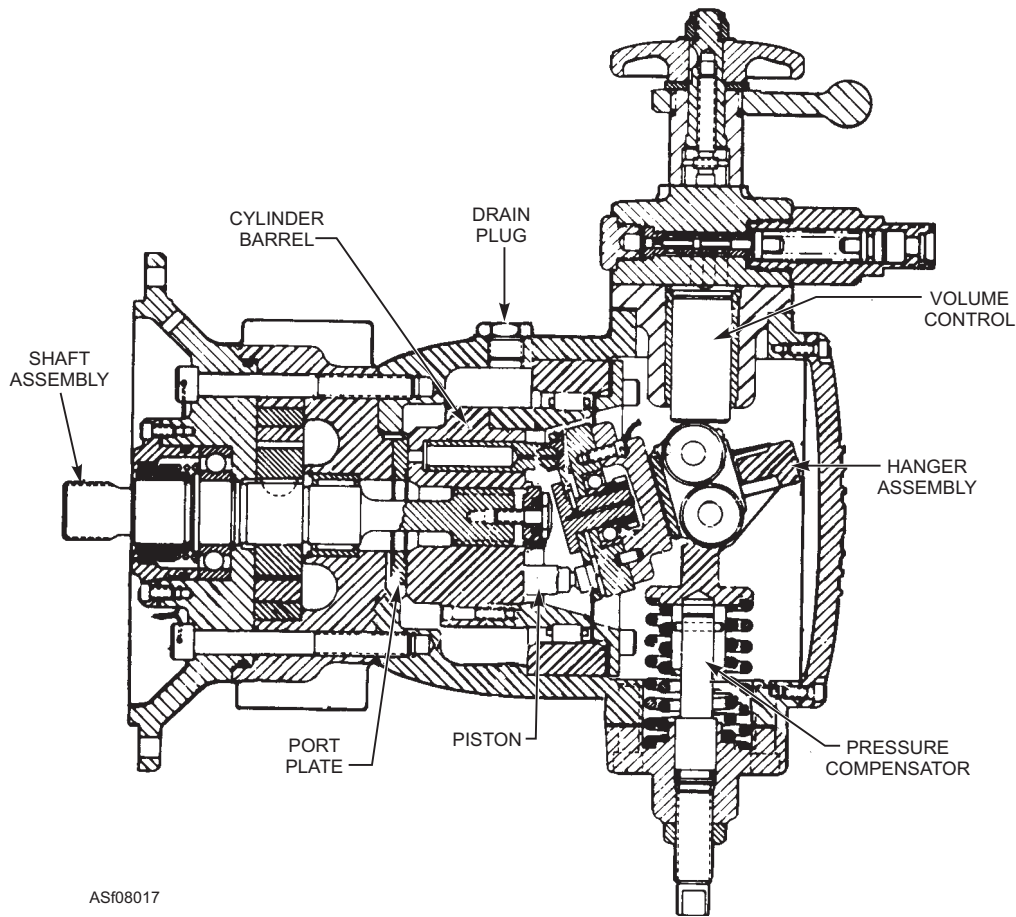

AS108017

Figure 8-17.—Variable displacement axial piston pump.

FILTERS

When small bits of metal, rubber, paper, dust, and dirt enter into a system, they contaminate the fluid. This may happen in a number of different ways. The contaminants may enter the system during the manufacturing of the components or during servicing and maintenance of the system; they can be created in the system by internal wear of the components, or because of deterioration of seals, hoses, and gaskets. These impurities can become suspended in the fluid and circulate throughout the system. Because of the close tolerances of system components, contamination in a system must be kept at an acceptable level; otherwise, the components are damaged, destroyed, or become clogged and inoperative. For these reasons, filters are essential in hydraulic systems.

A filter is a device whose primary function is the retention, by some porous medium, of insoluble contaminants from the hydraulic fluid. The porous medium is the screening or filtering material that allows fluid to flow through it but traps solid particles. The porous device that performs the actual process of

filtration is referred to as the filter element. Figure 8-18 shows some typical filter elements.

Filters are absolutely necessary to ensure proper operation of hydraulic systems and to achieve long service from the pumps, valves, and other components of the system. In hydraulic systems, filters may be located within the reservoir, in the pressure line, in the return line, or in any other location where they are needed to safeguard the system against foreign particles.

T-Type Filters

There are many types of filters, but most filter assemblies used in aircraft and support equipment are of the T-type shown in figure 8-19. The T-type filter assembly is composed of three basic units: a head assembly, a bowl, and a filter element. The head assembly is the part that is attached to the structure and connecting lines.

In most aircraft systems, you must have the hydraulic fluid flowing for in-flight hydraulic functions. In these systems, it would be better to have particle-contaminated fluid than to have no fluid at all.

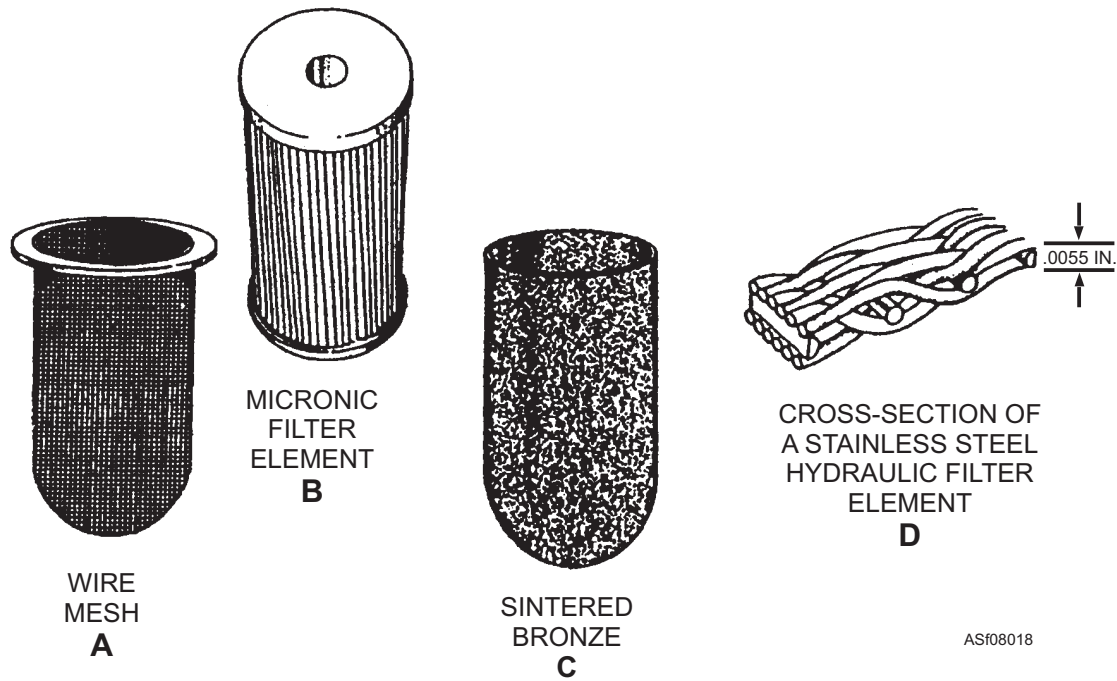

Figure 8-18.—Different types of hydraulic filter elements.

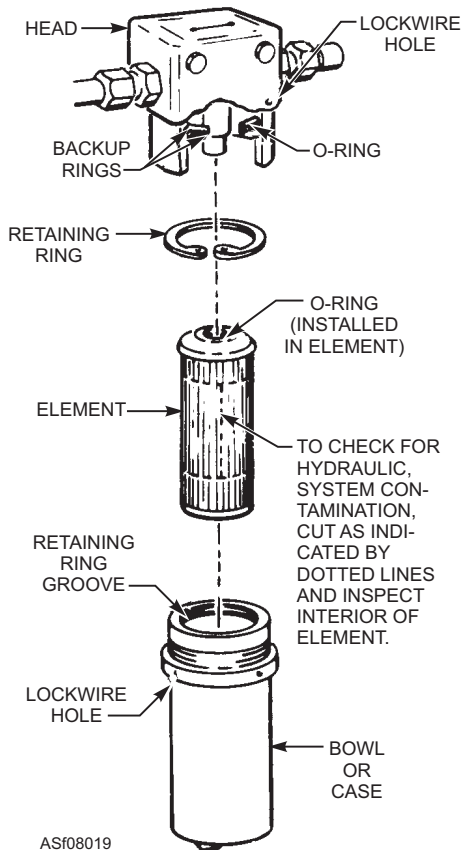

Figure 8-19.—T-type micronic filter assembly.

The bypass filter assembly is used in this type system. In aircraft hydraulic servicing equipment, the non-bypass filter assembly is used because you would not want to service an aircraft system with contaminated fluid.

Some filter heads contain a differential pressure indicator, which gives a visual indication of when the element should be changed. The bowl or filter case is the housing that holds the element to the filter head, and it is removed when the filter element requires replacement.

Filter Elements

The size of particulate matter in hydraulic fluid is measured in microns, (millionths of a meter). A micron is equivalent to 0.0000394 inch, and 25,400 microns equal 1 inch. The largest dimension of the particle is measured when determining its size. For comparison value, consider that the normal lower level of visibility to the naked eye is about 40 microns. (A grain of table salt measures about 100 microns; the thickness of a human hair is about 70 microns; and a grain of talcum powder is about 10 microns.) A graphic representation of the relative size of particles measured in microns is shown in figure 8-20.

MICRONIC-TYPE FILTER ELEMENTS.—*Micronic*, a term derived from the word micron, can be used to describe any filter element. Through usage, micronic has become associated with a specific filter with a filtering element made of a specially treated cellulose paper. The paper is formed in vertical convolutions (wrinkles) and is made in a cylindrical pattern. A spring in the hollow core of the element holds the element in shape (view B of fig. 8-18).

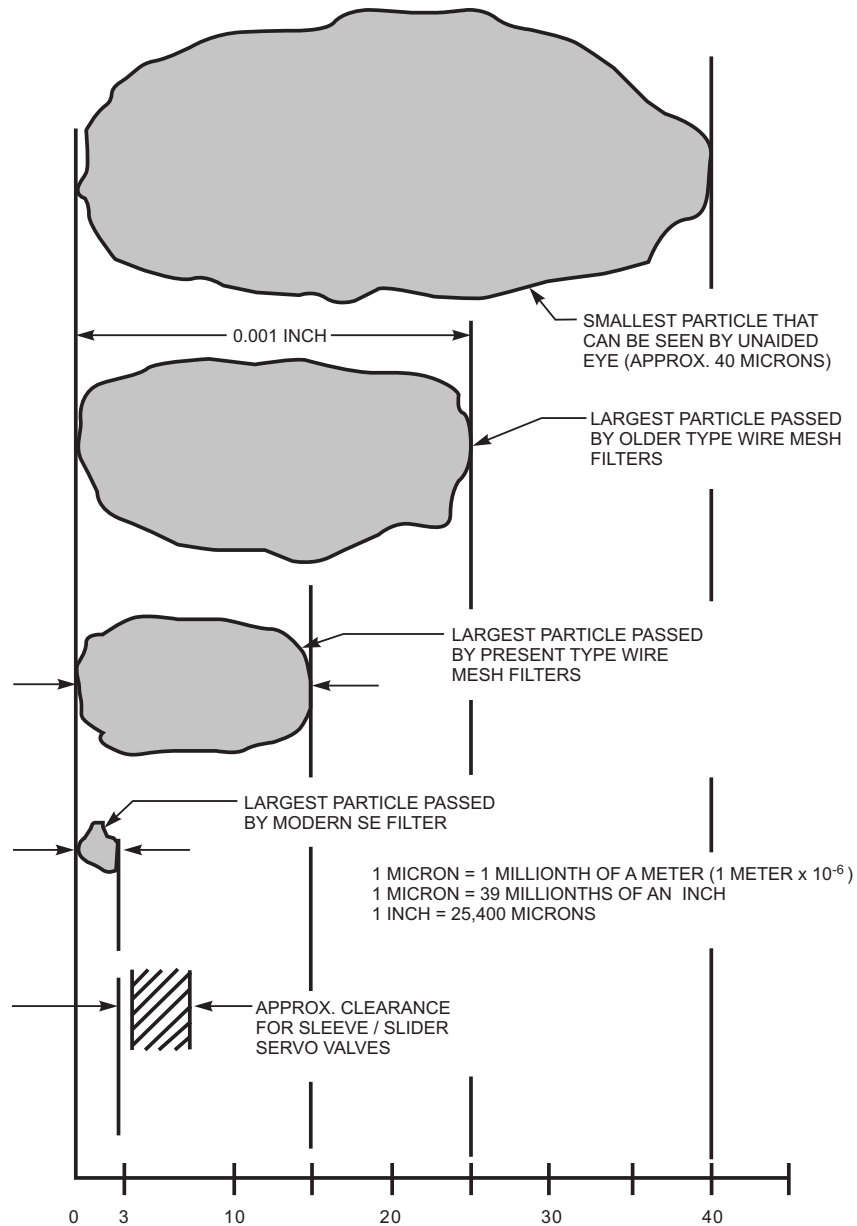

ASf08020

Figure 8-20.—Graphic comparison of particle sizes.

A typical micronic filter is shown in figure 8-21. This type of filter is designed to remove 99 percent of all particles 10 microns (0.00394 inch) in diameter and larger. The following discussion will help you to define this capability in meaningful terms: If 100 particles measuring 0.000394 inch in cross section were dropped into pure hydraulic fluid, a 10-micron filter will intercept 99 percent of these in one pass. A 40-micron particle is regarded to be the smallest that can be seen without magnification. A micronic filter assembly contains a replaceable micronic filter element and, in some cases, an integral pressure differential bypass valve. The micronic filter was first procured in the 1950's and widely used in aircraft and

support equipment. This type filter is still in use but is not specified in newer equipment.

The micronic filter assembly contains an integral bypass valve to prevent possible element collapse or system starvation. If the micronic filter element becomes loaded, the bypass valve will open when a predetermined pressure differential exists, allowing hydraulic fluid to bypass the filter element.

The replacement element is made of specially treated cellulose paper, formed in vertical convolutions (wrinkles). Generally, the micronic filter element slides onto the head and is held secure by the filter bowl, which has external threads machined on the outside and top. A groove machined around the base of

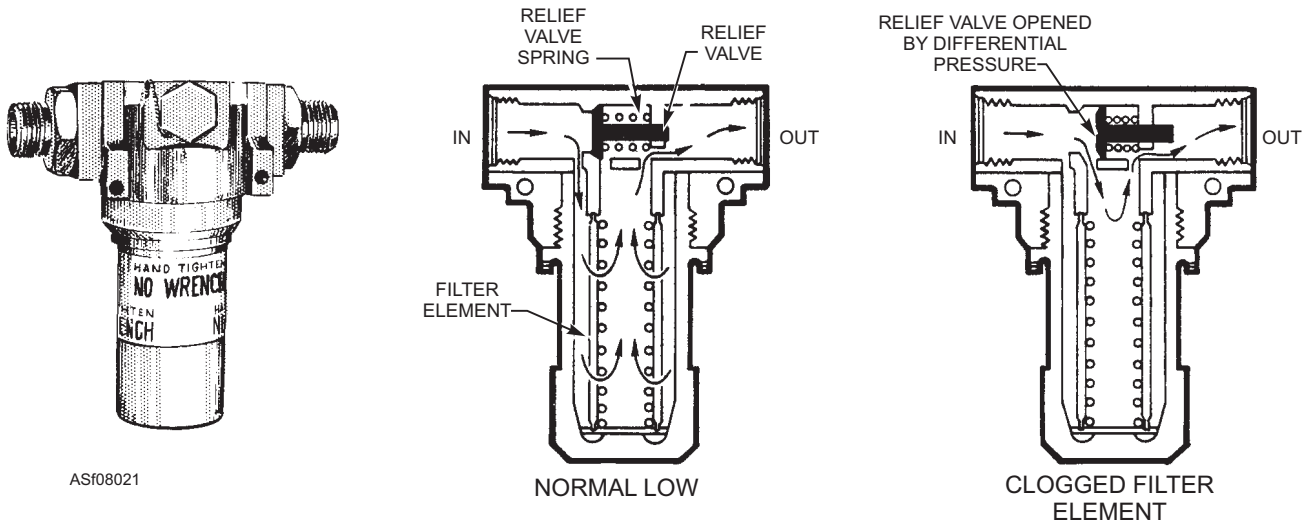

Figure 8-21.—Micronic filter.

the threads provides the location for packing between the filter bowl and body assembly.

Fluid enters the filter through the inlet port in the body and flows around the element inside the filter bowl. Filtering takes place as the fluid passes through the filtering element at the hollow core, leaving the dirt and impurities on the outside of the filter element. Filtered fluid then flows from the hollow core to the outlet port in the body and into the system.

The bypass pressure-relief valve in the body allows fluid to bypass the filter element and pass directly through the outlet port in case the filter element becomes clogged. In most filters of this type, the relief valve is set to open if the pressure differential exceeds 50 psi. In other words, if the pressure at the filter inlet port was 1,500 psi and the pressure at the outlet port dropped below 1,450 psi, the relief valve would open.

NOTE: Some filters of this type are not equipped with this type of bypass pressure-relief valve.

Micronic filter elements are replaced with new filter elements at regular intervals. These intervals are specified in the applicable MIM and maintenance requirements cards (MRCs). The following procedure for removing and replacing filter elements is typical of almost all systems:

1. Relieve system pressure.
2. Cut the lockwire and remove the filter case (bowl) from the filter head (body).
3. Unscrew and remove the filter case, using a slight rocking and downward pull on the case after the case threads are free from the filter.

4. The filter element shown in figure 8-19 is removed from the case by extracting the retaining ring and removing the filter element.

NOTE: At the time of filter element replacement, you should never try to gauge its condition by visual inspection alone. The naked eye cannot detect particles smaller than 40 microns. Consequently, the element could be heavily contaminated with 10- to 20-micron particles, and the only way the condition of this element can be determined is by performing a back pressure flow check on a test stand.

CAUTION

When selecting a new filter element, do not be guided by its appearance and physical dimensions alone. Always go by the part number. Many elements look identical but will disintegrate if installed in the wrong type of fluid; this will cause a good hydraulic system to become contaminated.

5. Prior to installation of the replacement element, the filter head and filter case must be cleaned and inspected for damage. All damaged parts must be replaced.
6. Replace all O-ring seals.
7. Fill the filter case, if practical, one-half full of hydraulic fluid, and install the filter element in its case and screw the case into the filter head. The correct torque is usually handtight or handtight plus one-eighth turn. Always check the specific MIM.
8. Pressurize the system and inspect the filter assembly for leaks. If it is found satisfactory,

replace the lockwire between the filter case and the head assembly.

METAL-TYPE FILTER ELEMENTS.—The two most common types of metal filter elements are the sintered bronze and the stainless steel. The sintered bronze element consists of minute bronze balls joined together as one solid piece, but it still remains porous. The process of joining the balls together is known as the *sintered process*. Like the micron filter described previously, filters using the sintered bronze elements are equipped with a bypass valve. If the element becomes clogged, the bypass valve will open, allowing the fluid to bypass the filter element when a predetermined pressure differential exists. The sintered bronze element can be cleaned, tested, and reused several times. The stainless steel filter element may be of corrugated, sintered, or mesh construction.

WIRE MESH FILTER ELEMENTS.—A wire mesh filter element is made of a fine wire mesh (screen) and is usually used where the fluid enters and/or leaves a container or component (view A of figure 8-18). The size of wire mesh openings vary with the particular filter element, but normally a wire mesh filter element removes only the larger particles of contamination from the fluid.

A wire mesh filter element can be reused. It should be removed, cleaned, and reinstalled at scheduled intervals or when it becomes dirty. Replace it when it cannot be properly cleaned or is damaged.

Multiple Filtering Elements

Normally, only one element is used in each filter; however, some equipment use two or more elements to obtain the desired degree of filtration. In this arrangement, the filter elements are usually designed so that one fits inside the other. The elements may be of the same type or of a different type. An example of equipment that uses this filter arrangement is the portable hydraulic test stand (in final filtration stage) used on an aircraft.

Bypass Characteristics

A full flow, micron, bypass filter is shown in figure 8-22. This filter provides a positive filtering action. However, it offers resistance to flow, particularly when the element becomes dirty. For this reason, a full flow filter usually contains a bypass valve, which automatically opens to allow the fluid to bypass the element when the flow of fluid is restricted because of contamination buildup on the element.

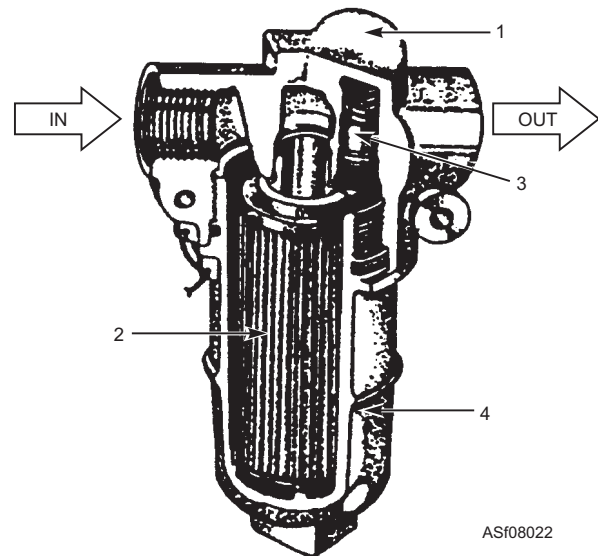

- | | |
|-------------------|----------------|
| 1. Filter head | 3. Relief bowl |
| 2. Filter element | 4. Filter bowl |

Figure 8-22.—Full flow, bypass hydraulic filter.

Hydraulic fluid enters the filter assembly through the inlet port in the body and flows around the filter element inside the filter bowl. Filtering takes place as the fluid passes through the filter element and into the hollow core, leaving dirt and impurities deposited on the outside of the filter medium. The filtered fluid then flows from the hollow core, through the outlet port, and continues on through the system.

The bypass relief valve in the body allows the fluid to bypass the filter element and pass directly into the outlet port if the filter element becomes clogged. In many micron filters, the relief valve is set to open when the differential in pressure exceeds 50 psi. For example, if the pressure at the filter inlet port is 90 psi and the pressure at the outlet drops below 40 psi, the bypass valve opens and allows the liquid to bypass the element.

Contamination Indicators

Hydraulic systems in support equipment that is used to service aircraft hydraulic systems use a non-bypass filter, so some type of contamination indicator must be used to prevent damage to the hydraulic system if these filters become clogged. A pressure switch, connected across the filter to sense the pressure differential, actuates at a preset pressure (usually 100 psi) and causes a warning device to operate; this indicates that the filter is clogged. The warning device may be a button popping up on the filter or control panel, a warning light illuminating at

the control panel, a buzzer or horn sounding, or the motor (driving the hydraulic pump) secured.

Contamination indicators are also used on some bypass filters. The full flow, bypass, electrical-indicating hydraulic filter (shown in figure 8-23) is used in many hydraulic systems of modern support equipment. This filter uses one or a combination of the contamination indicators previously described.

Under normal conditions the fluid enters the inlet of the filter, passes through the filter element, and leaves the filter through the outlet. As the fluid passes through the filter element, impurities are deposited on the outside of the element. As the deposits accumulate, they cause a differential pressure to build up between the inlet and outlet of the filter. The differential pressure is sensed across the contamination indicator switch, causing the red indicator button to pop up.

When that happens, the equipment should be stopped and the filter serviced (cleaned or replaced).

NOTE: It is important to remember that cold hydraulic fluid can produce a false pressure indication. To prevent needless changing of filters, fluid should be at operating temperature for a true indication of contamination. Some filters, such as that shown in figure 8-23, have a button to reset the switch after the filter has been serviced. However, on other filters, the switch resets automatically when the differential pressure is relieved.

If the filter is not properly serviced following the contamination indication, and the equipment is kept in operation, the differential pressure continues to build. At 100 ± 10 psi, the bypass valve will open and allow the fluid to flow straight through, bypassing the filter element. But on this filter, the contamination

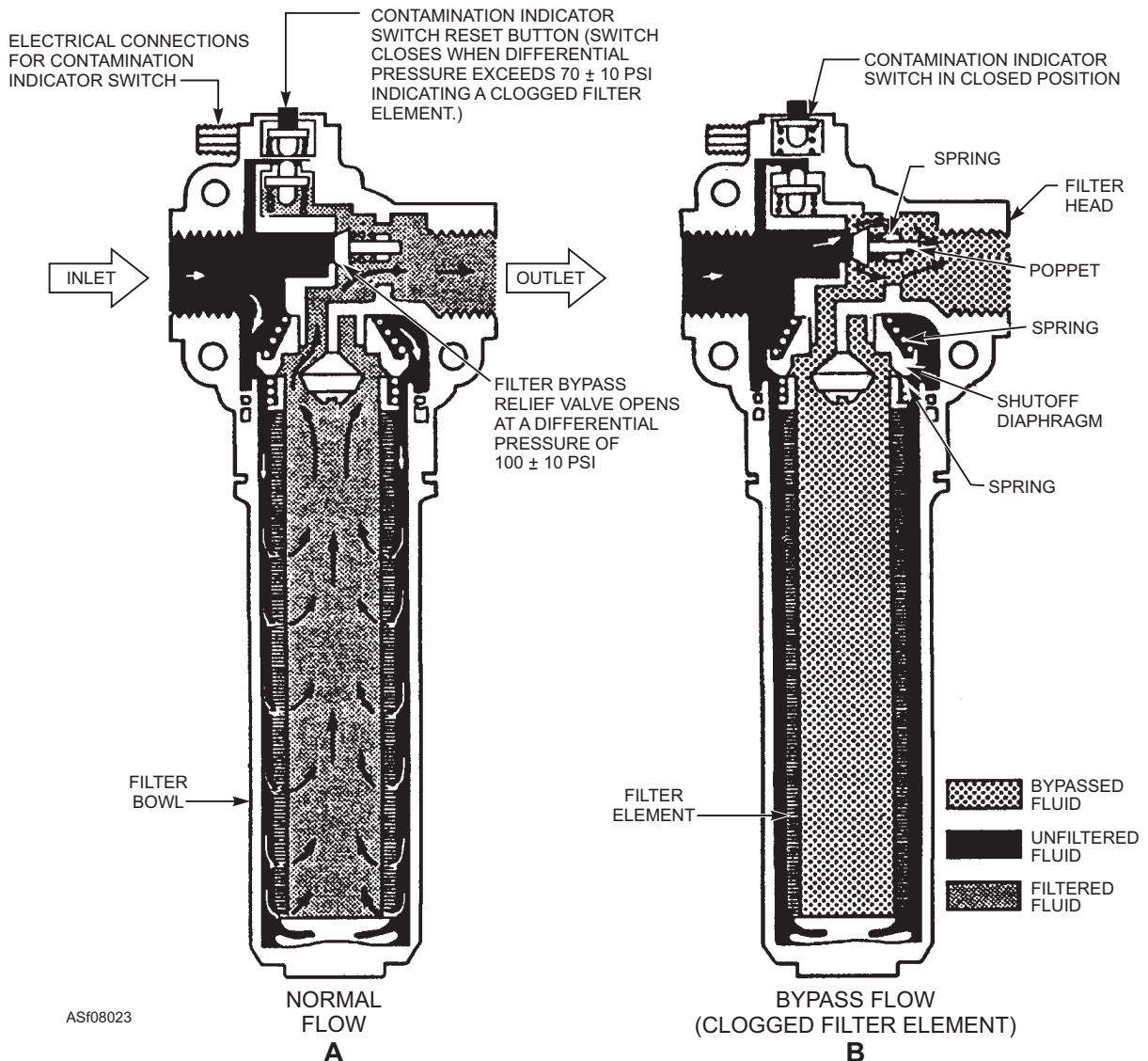

Figure 8-23.—Full flow bypass, electrical indicating hydraulic filter.

indicator is to warn the operator that the filter element is clogged. The equipment can then be stopped before the bypass valve opens, thus preventing contaminated fluid from being passed through the hydraulic system.

Support Equipment Hydraulic Servicing Equipment Filters

To ensure delivery of contaminant-free hydraulic fluid, all aircraft hydraulic servicing and test equipment use 3-micron (absolute) non-bypass filtration in their fluid discharge or output pressure lines. With many test stands, the filter used for this application, in addition to having a low micron rating, must be capable of withstanding high collapse pressures and hold large amounts of dirt. Filter assemblies and elements designed specifically for this type of service are available from major filter manufacturers and are presently being used in support equipment.

Several different types of 3-micron (absolute) high-pressure filters are commonly used in support equipment. Early models (fig. 8-24) of filter assemblies used a two-stage design in which the assembly contained both a large non-cleanable primary filter cartridge and a cleanable metallic secondary element. With this design, the non-cleanable primary element provides the required 3-micron filtration and retains within its filter medium virtually all particulate matter removed from the fluid. The cleanable secondary element has a rating of 15 microns (absolute), and is physically located inside

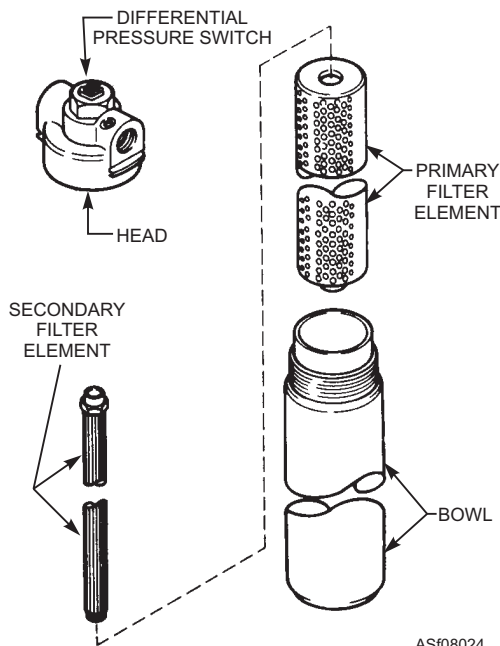
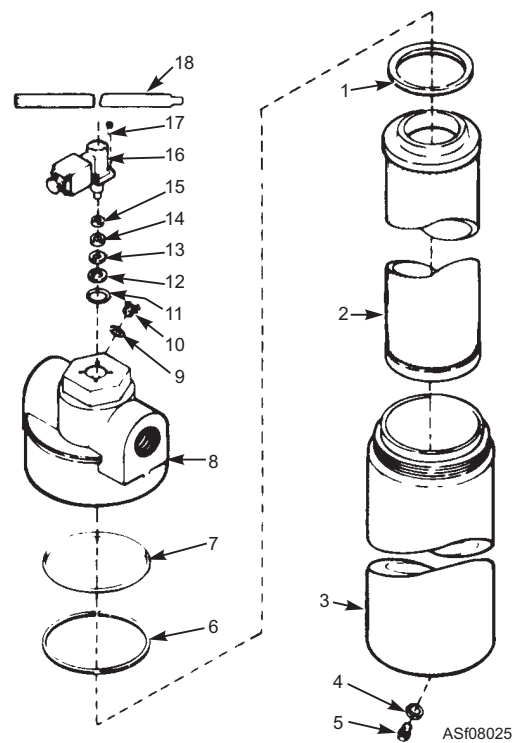

Figure 8-24.—High-pressure filter.

and downstream of the primary element. The second stage filters out any media material released by the primary element and protects the system in the event the primary element should fail due to excessive differential pressure. The secondary element also protects the system from contamination while the primary element is being replaced.

Other support equipment filters use only a single stage, which consists of one large non-cleanable filter cartridge (fig. 8-25). This configuration has been made possible by improvements in filter elements that permit manufacture of a non-cleanable element capable of withstanding 5,000 psi differential pressures and displaying negligible shedding of media material. Filtration efficiency and dirt-holding capacity of the single-stage filter is comparable to that of the two-stage design, and it has the advantage of not requiring second-stage element cleaning. Non-cleanable, single-stage elements can be used to replace both the primary and secondary elements in most two-stage filter assemblies. Applicable



- | | |
|----------------------|----------------------------------|
| 1. Boss seal | 10. Fill plug |
| 2. Filter element | 11. Preformed packing |
| 3. Filter bowl | 12. Backup ring |
| 4. Preformed packing | 13. Preformed packing |
| 5. Drain plug | 14. Sea ring |
| 6. Backup ring | 15. Preformed packing |
| 7. Preformed packing | 16. Differential pressure switch |
| 8. Filter head | 17. Socket head cap screw |
| 9. Preformed packing | 18. Identification plate |

Figure 8-25.—Typical high-pressure support equipment filter assembly.

maintenance instructions should be consulted to determine filter element requirements.

Filter assemblies used in support equipment vary in physical size according to their maximum flow rating. Common sizes in use are 10, 20, and 30 gal/min, with the flow rating determining the overall length of the elements used and the filter bowl. To minimize supply requirements, at least one manufacturer provides non-cleanable primary stage elements in the form of 10 gal/min cartridges capable of being connected together with a simple coupling device. By joining the required number of 10 gal/min elements together, 20 or 30 gal/min cartridges can be locally assembled. All of the support equipment filter assemblies discussed are of the non-bypass type and are equipped with differential pressure indicators to warn of a loaded element. The differential pressure indicators are, in most cases, preset to activate with an element pressure drop of 100 ± 15 psi, which represents approximately 90 percent of the filter's total dirt-holding capacity.

Unlike most filter elements, 3-micron, high-pressure support equipment filters are not normally replaced on a prescribed periodic basis. Because of their large dirt-holding capacity and nature of service, it is more effective to replace such elements only when indicated as being loaded by their associated differential pressure indicators. Element replacement procedures vary with the particular type, and applicable maintenance instructions should be consulted for specific procedures.

VALVES

Once the pump has begun to move the fluid in a hydraulic system, valves are usually required to control, monitor, and regulate the operation of the system. While the pump is recognized as the heart of a system, the valves are very important devices for providing flexibility.

A valve is a device that controls the flow or pressure of fluid in a fluid power system. Valves are usually classified as to the type of control they provide:

- Flow control valves—Control the volume of fluid going to various parts of the system.
- Pressure control valves—Regulate pressure in the system.
- Directional control valves—Direct a flow of fluid to and from an actuator. Directional control

valves are also commonly called *transfer valves*, *selector valves*, or *control valves*.

It is beyond the scope of this course to cover all of the many varieties of valves in use today. However, since more elaborate valves are combinations or variations of basic types, only the basic types are covered here. For a more detailed study of the operation of the various types of valves, consult *Fluid Power*, NAVEDTRA 14105.

Valves, like pumps, are precision made. Usually, no packing is required to prevent leaking between valve elements and valve seats because of their closely machined clearances. This is one of the reasons why minimizing system contamination is so important, as even the most minute particles of dirt, dust, and lint can defeat the seal between valve elements and valve seats.

Flow Control Valves

The ordinary water faucet is a good example of a flow control valve. Turning the faucet handle changes the opening of the valve, which controls the amount of water that passes. Many of the flow control valves used in fluid power systems are similar to the water faucet.

Many flow control valves are operated manually, similar to the operation of a water faucet. For example, the release valve in a hydraulic jack system is a flow control valve of this type. The release valve is closed during the raising operation, and is then opened during the lowering operation. The speed of the lowering operation depends upon the rate of flow of the fluid through the release valve, which, in turn, depends upon the amount that the release valve is opened.

A restrictor is another type of flow control valve used in fluid power systems. Its purpose is to limit the speed of an actuator. (An actuator is a device that transforms fluid pressure into mechanical force to move some mechanism. A hydraulic motor is one type of actuator, as it converts fluid under pressure into rotary motion. Another example of an actuator is the lift cylinder of a forklift.)

A two-way restrictor restricts the flow of fluid in both directions. This type of restrictor is simply a valve containing a small orifice for the passage of fluid. The rate of flow through the valve is determined by the size of the orifice. In some two-way restrictors, the size of the orifice is adjustable. This type is called a *variable restrictor*.

In some cases it is necessary to control the speed of an actuator in only one direction. For example, the lift

cylinder of a forklift requires a full flow of fluid while raising a load, but only a partial flow during the lowering of the load. This is often accomplished by using a one-way restrictor in the line. The restrictor allows full flow during the lifting operation, but permits only a restricted flow, thus slowing the speed of actuation, during the lowering operation. Figure 8-26 shows a typical one-way restrictor.

When the fluid flows from left to right in the restrictor, shown in figure 8-26, the pressure of the fluid overcomes spring tension and forces the cone to the open position. This action permits free flow through large orifices in the valve. When the fluid flows from right to left, the cone is forced closed and the flow of fluid is restricted through the small orifice in the cone.

Pressure Control Valves

The most common pressure control valve is the relief valve. Relief valves are pressure-limiting devices that are used in most hydraulic systems as safety valves. A relief valve provides protection against overloading system components. In this way they prevent damage to the system due to over-pressurization. Relief valves are also used to limit the force that can be exerted by an actuator. One example of a relief valve that was described earlier in this chapter was the single-action hydraulic hand pump, shown in figure 8-13. Many of the relief valves found in fluid power systems operate similarly to this valve.

SIMPLE RELIEF VALVES.—A simple two-port relief valve is shown in figure 8-27. An adjusting screw is provided so that the valve may be regulated to any given pressure, allowing it to be used on a variety of systems. Before the system pressure can become high enough to rupture the tubing or damage the system units, it exceeds the pressure required to overcome the relief valve spring setting. This pushes the ball off of its seat and bypasses excess fluid to the

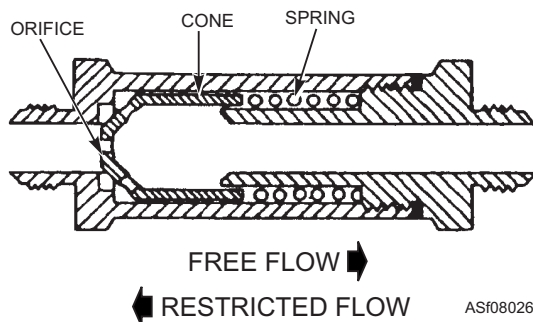
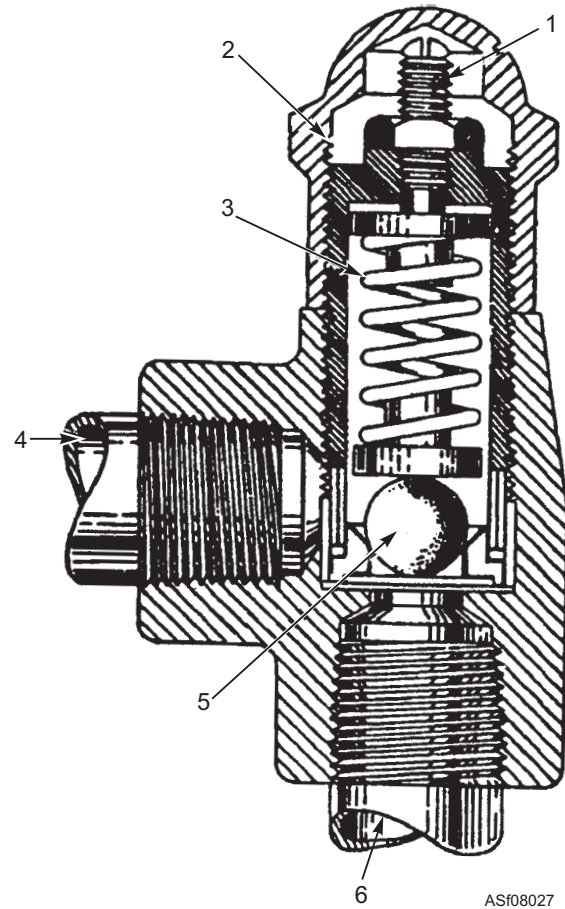

Figure 8-26.—One-way restrictor (check valve).



- | | |
|------------------------|------------------|
| 1. Adjusting screw | 4. Return port |
| 2. Adjusting screw cap | 5. Ball |
| 3. Spring | 6. Pressure port |

Figure 8-27.—Relief valve.

reservoir. When the system pressure decreases to a safe level, the spring setting reseats the ball.

PILOT-OPERATED RELIEF VALVES.—A more complex relief valve is the pilot-operated relief valve, shown in figure 8-28. View A shows the relief valve in the closed position. View B shows the valve in the open position. In the closed position, fluid at system pressure flows through the inlet port (2 or 8), around the piston (1), and out the outlet port (2 or 8). (Inlet and outlet ports may be used interchangeably when the valve is mounted in the pressure line, or one port may be plugged when the valve is connected with a “tee” fitting off the pressure line.)

By means of the passage (10) in the piston (1), fluid also flows into chamber 3 and acts on the pilot valve (4), which is held on its seat by spring 5. The force of spring 5 is regulated by the adjusting screw (6) and determines the pressure setting of the valve. Valve operation will not remain steady if the pilot valve (4) does not seat properly.

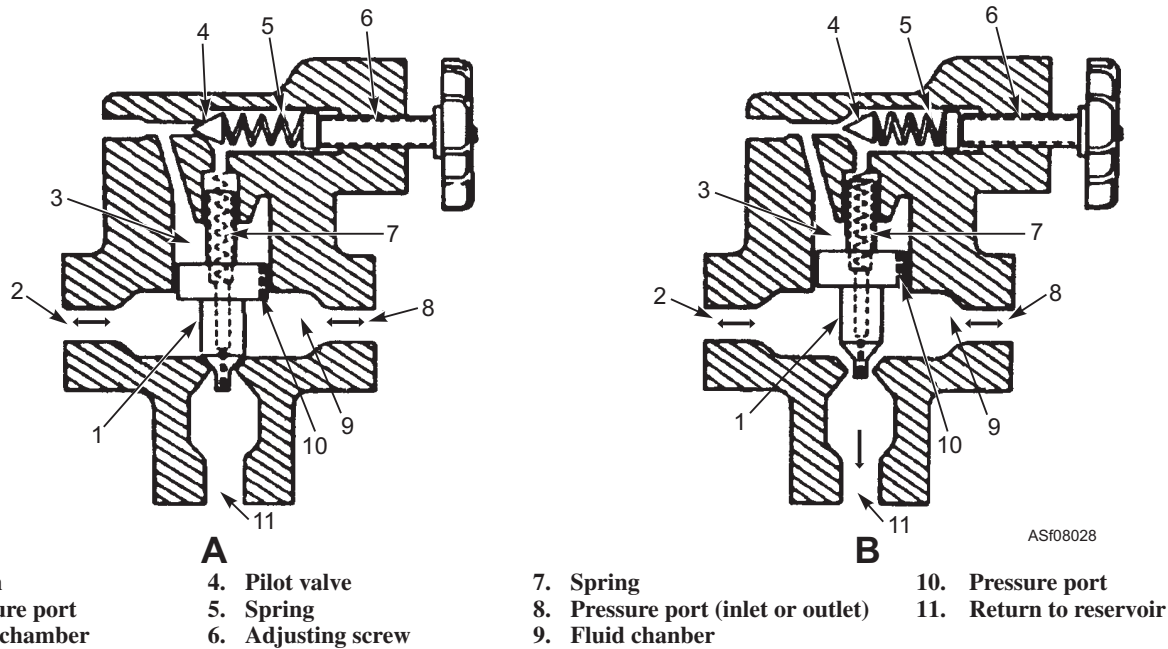

Figure 8-28.—Pilot-operated relief valve.

Spring 7 will hold the piston (1) closed as long as the pressure in the chambers (3 and 9) remain equal. The piston, in this condition, is referred to as being in hydraulic balance.

When an excessive pressure surge occurs, the pressure in chamber 3 stays basically unchanged because of the restriction of fluid flow of the fluid passage (10). The pressure surge in chamber 9 overcomes the combined pressure of chamber 3 and spring 7, and opens the piston (1) momentarily, decreasing the surge pressure by allowing fluid to flow from chamber 9 to the return (11).

In a gradual pressure increase, the pressure in the chambers (3 and 9) remains balanced. When the pressure in chamber 3 equals the tension of the spring (5), the pilot valve (4) opens, thus decreasing the pressure in chamber 3 by relieving the pressure through the centrally drilled passage in the piston (1). The pressure in chamber 9 then exceeds the combined pressure of chamber 3 and spring 7, and thus opens the piston (1).

In actual operation, the piston (1) will open just enough to allow excess fluid to escape. It will remain in the open or throttled position as long as the resistance to fluid flow (causing pressure buildup) is present in the system.

When system pressure decreases to the preset setting of the pilot valve, the tension of the spring (5) forces the pilot valve (4) on its seat. Because of the passage (10) in the piston (1), fluid pressure equalizes

in both chambers 3 and 9. The tension of spring 7 then closes the piston (1).

Relief valves of this type are used in some hydraulic test stands.

PRESSURE REGULATOR VALVES.—As the name implies, regulator valves are designed to regulate system pressure between maximum and minimum levels. These valves are often called *unloading valves*. They are designed to remove the system load from the pump once the desired system pressure has been reached.

The functions performed by a regulator valve are accomplished by its two operational phases—cut-in and cutout. A regulator is said to be cut-in when it is directing fluid under pressure into a system. A regulator is cutout when it is bypassing fluid into the return line and back to the reservoir. Figure 8-29, view A, shows a typical pressure regulator in the cut-in state.

In view A of figure 8-29, you can see that the pump supplies pressure to the top and bottom of the regulator valve. At the top, the pressure acts on the 1/4 square inch of the ball. On the bottom, the pressure acts on the 1 square inch of the piston. This creates a force differential between the two.

Pressure on the piston tries to lift the ball off of its seat, but the force generated by the spring (600 lb) and the additional pressure exerted on the ball by the fluid in the upper part of the valve works to keep the ball seated. As long as the force differential between the ball and the piston is less than the 600 pounds of the

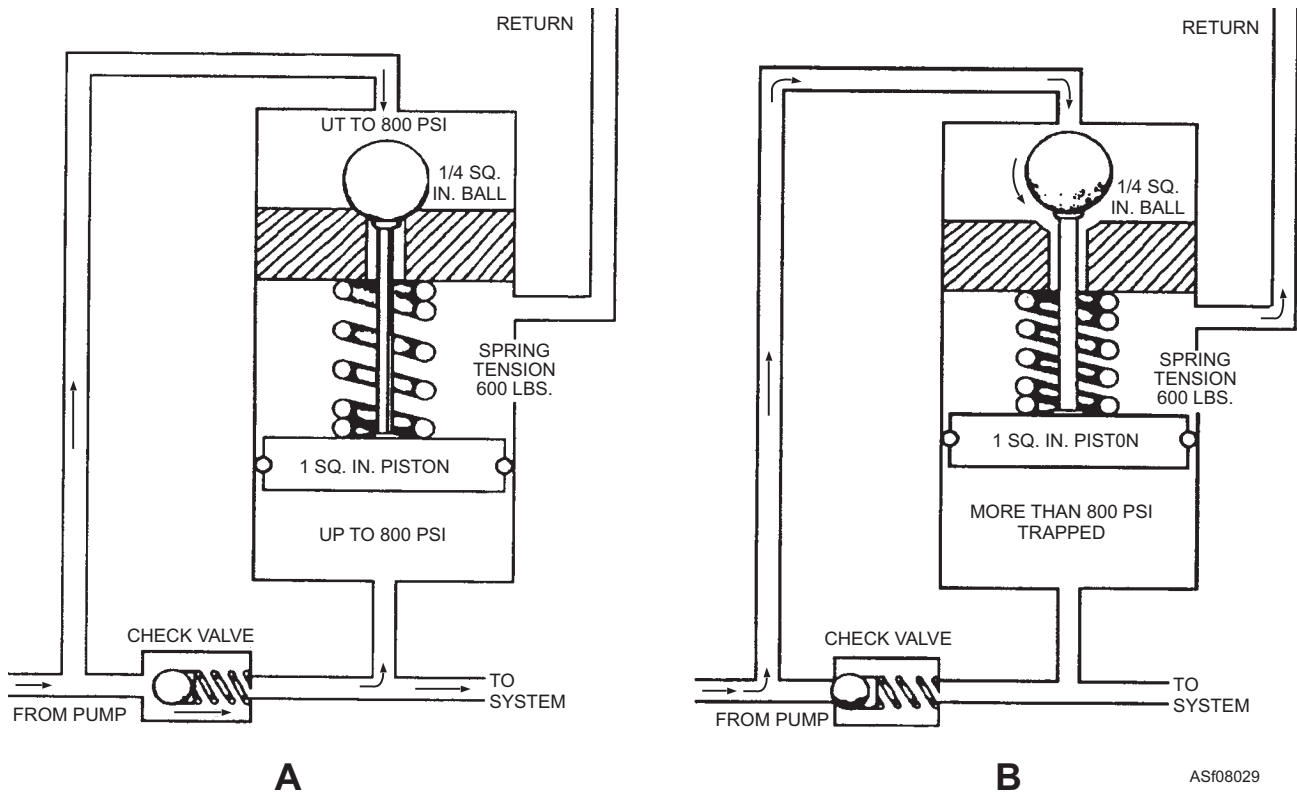

Figure 8-29.—Pressure regulator in the cut-in state (view A); and the cut-out state (view B).

ASf08029

spring tension, the ball will remain seated. However, as soon as that differential exceeds 600 pounds, the piston will overcome the spring and lift the ball off of its seat, as in view B of the figure.

When the ball is unseated, pressure in the top of the valve drops immediately. At this point, the importance of the check valve can be seen. With the sudden reduction in pressure, the check valve snaps shut, and fluid trapped in the system line continues to hold the regulator piston in the raised position. This trapped fluid also maintains pressure on the system until the mechanism actuates or it is relieved by internal or external leaking, either of which will cause the regulator to cut back in.

Hydraulic systems that use fixed displacement pumps require pressure regulator valves. Those using variable displacement pumps do not.

Directional Valves

The purpose of a directional valve (also known as a *selector valve*, *transfer valve*, or *control valve*) is to control the direction of fluid flow, which, in turn, controls the operation or direction of a mechanism. Such valves are classified in several ways, such as by the number of ports in the valve housing, by the type of control, and by the specific function of the valve. Another type of classification is by the type of valving

element, which is the most common method. A directional control valve can be one-way, two-way, three-way, or four-way.

The valve element of a directional valve may be any one of three types:

- A poppet—in which a piston or ball moves on and off of a seat.
- A rotary spool—in which the spool rotates about its axis.
- A sliding spool—in which the spool slides axially in a bore.

Directional valves may be actuated mechanically, manually, electrically, hydraulically, or pneumatically.

POPPETS.—Figure 8-30 illustrates the operation of a simple poppet valve. The valve consists of a movable poppet that closes against a valve seat. In the closed position, fluid pressure on the inlet side tends to hold the valve tightly closed. Force applied to the top of the poppet stem opens the poppet and allows fluid to flow through the valve.

The poppet, usually made of steel, fits into the center bore of the seat. The seating surfaces of the poppet and the seat are lapped or closely machined so that the center bore will be sealed when the poppet is seated. An O-ring seal is usually installed on the stem

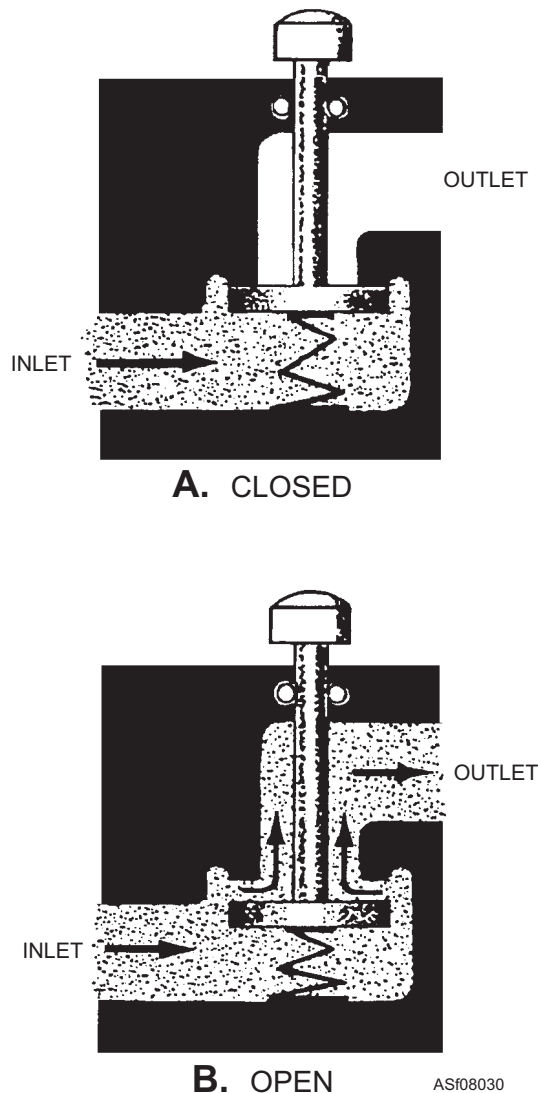

AS108030

Figure 8-30.—Operation of a simple poppet valve.

of the poppet to prevent leaks past this portion of the housing. In most valves, the poppet is held in the seated position by a spring. Some more complex valves may have multiple poppets.

ROTARY SPOOLS.—A rotary spool directional control valve has a round core with one or more passages or recesses in it. (See figure 8-31.) The core is mounted within a stationary sleeve. As the core is rotated within the stationary sleeve (generally by a hand lever or knob), the passages or recesses connect or block the ports in the sleeve. The ports in the sleeve are connected to the appropriate pressure, working, and return lines of the fluid power system.

SLIDING SPOOLS.—A sliding spool is probably the most common type of valve element used in directional control valves. Operation of the valve is illustrated in figure 8-32. The valve is so named because the shape of the valve element resembles that

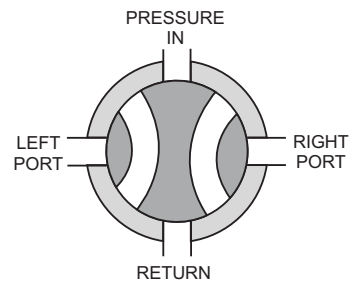

AS108031

Figure 8-31.—Operation of a rotary spool valve.

of a spool and because the valve element slides back and forth to block and uncover ports in the housing.

In view B of the figure, the valve is shown in the neutral position (no fluid flow). By moving the spool valve to the left position (as in view A), fluid flows from the pressure line out through the right port, and returns back through the left port to the return line. Moving the spool to the right position (as in view C) has a similar result; the left port becomes the pressure port, and the right port becomes the return port.

Like all classes of directional control valves, various methods are used for positioning the sliding spool valve. Some of the more common methods are hand levers, cam angle plates, directional control arms, and self-regulating poppet valve linkages.

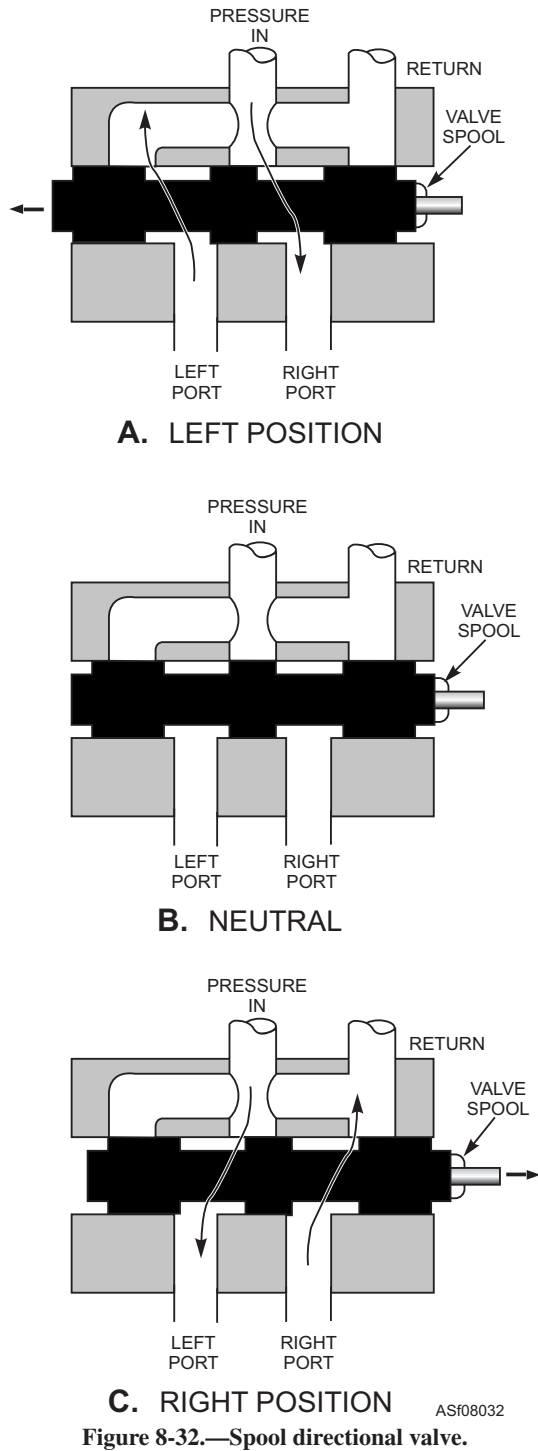

Figure 8-32.—Spool directional valve.

CHECK VALVES.—A check valve is normally classified as a one-way directional control valve (although some manuals might identify them as flow control valves). However, check valves permit flow in one direction and prevent flow in the other. The force of the fluid in motion opens a check valve, and it is closed by fluid attempting to flow in the opposite direction, aided by the action of a spring or by gravity. You could say that check valves are the “diodes” of the hydro-pneumatic world.

Check valves are probably the most widely used valves in fluid power systems. Check valves are also used as integral parts of some more complex valves, such as sequence valves and counterbalance valves. They are also used in pressure regulator valves, such as the one pictured in figure 8-29. A variation of the check valve—the orifice check valve—allows free flow in one direction and a limited or restricted flow in the opposite direction. (See figure 8-26.)

Check valves come in various designs. As shown earlier, balls, cones, and sleeves are commonly used as valve elements. Poppets, pistons, spools, and discs are also used as valve elements in some types of check valves.

CLOSED-CENTER DIRECTIONAL CONTROL VALVES.—The closed-center directional control valve shown in figure 8-33 is a four-way control valve that is widely used in support equipment. It has four ports—a pressure port, a return port, and two working ports. The pressure port is connected to the main pressure line, and the return port is connected to the reservoir. The two working lines are connected to

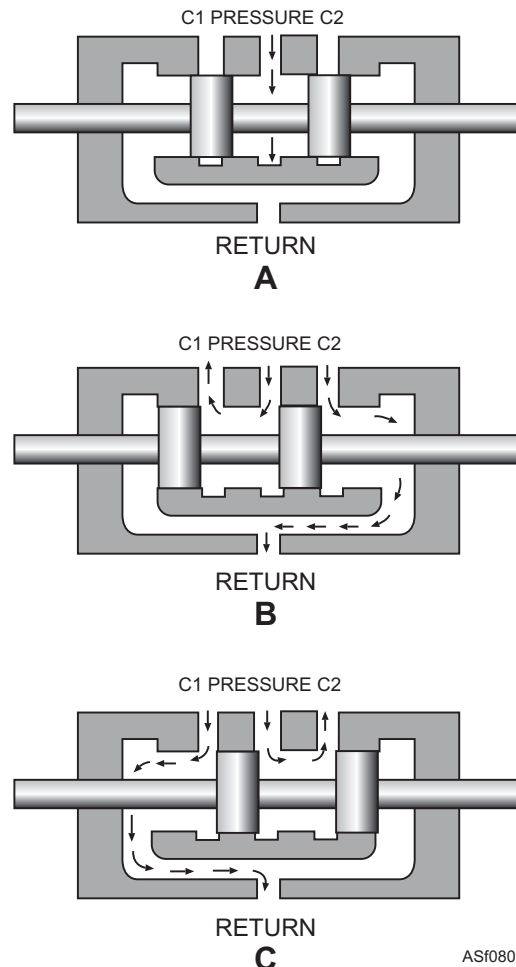

Figure 8-33.—Closed-center directional control valve.

the actuating unit and serve alternately as pressure and return lines. There are two main types of four-way control valves—the closed-center and the open-center.

Figure 8-33 shows the operation of the valve. View A shows the valve in the neutral position. In this position, there is no flow through the valve, as the two working ports (C1 and C2) are blocked off from the pressure and return ports.

View B shows the valve with the spool moved to the left of the neutral position. In this position, one working port (C1) is open to pressure, and the other working port (C2) is open to return. This allows the fluid to move in one direction.

In view C of figure 8-33, the spool is moved in the opposite direction, to the right of the neutral position, the working port (C2) is open to pressure, and the working port (C1) is open to return.

OPEN-CENTER DIRECTIONAL CONTROL VALVE.—Figure 8-34 shows the operation of a typical open-center control valve. When this type of valve is in the neutral position, as shown in view A, fluid flows into the valve through the pressure port (P), through the hollow spool, and to the return.

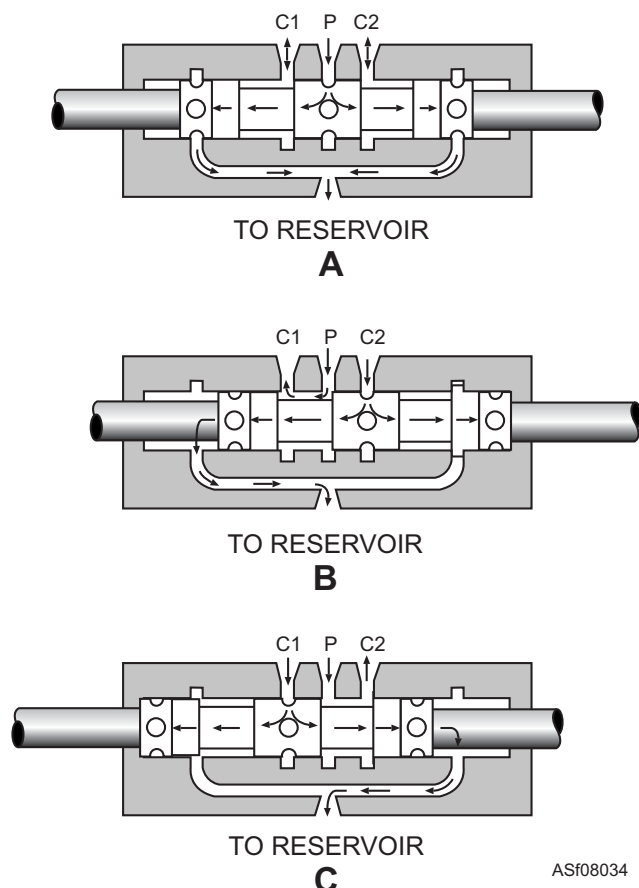

ASF08034

Figure 8-34.—Open-center directional control valve.

In view B, the spool is moved to the right of the neutral position. In this position, one working line (C1) is open to pressure, and the other working line (C2) is open, through the hollow spool, to return. View C shows the flow of fluid with the spool moved to the left of neutral.

These control valves may be designed as individual units. However, in some systems, such as the hydraulic systems of weapon loaders and some forklifts, two, three, or four control valves are combined into one controlling unit.

Most directional control valves used in support equipment are operated manually, either directly or through mechanical linkage. In some systems, these valves are operated electrically by solenoids.

This is accomplished through the use of one or more solenoids. A solenoid is a hollow, tubular-shaped electric coil, made up of many turns of fine insulated wire and possessing the same properties as an electromagnet. The hollow coil imparts linear motion to a movable core (or plunger) placed within the hollow coil of the solenoid.

To electrically operate the four-way valves shown in figures 8-33 and 8-34, a solenoid is connected to each end of the valve. When the hollow coil of one solenoid is energized, the plunger of the solenoid moves and positions the sliding spool accordingly. By energizing the solenoid on the opposite end, the sliding spool moves in the opposite direction. Springs are usually provided to move, and hold, the sliding spool to the neutral position when neither solenoid is energized. The solenoids are electrically connected to switches that may be secured in a convenient location for the operator. Solenoids are also used to operate two- and three-way valves.

NOTE: In some subsystems, only one working line is required from the control valve to the actuator. In such systems, three-way valves are used. A three-way valve contains three ports—a pressure port, a return port, and one working port. Otherwise, three-way valves operate much the same as four-way valves.

ACCUMULATORS

The purpose of an accumulator in a hydraulic system is to store fluid under pressure. The following are several reasons why it is useful to do this:

- An accumulator can act as a cushion against pressure surges in the system.

- By storing energy in the form of fluid under pressure, an accumulator can supplement the pump's output when the pump is under peak load.
- In the event of normal hydraulic system failure, the energy stored in an accumulator can be used to actuate a unit of the system. For example, sufficient energy can be stored in the accumulator for several applications of the brakes of a self-powered vehicle.

Several types of accumulators are shown in figure 8-35. Of these, the cylindrical (cylinder) type is the one most often found in ground support equipment. This type of accumulator is used in the hydraulic systems of weapon loaders, maintenance stands, engine stands, and aircraft spotting dollies to name a few.

A cylindrical accumulator consists of a cylinder and a piston assembly. Attached to both ends of the cylinder are end caps. An internal piston separates the fluid and nitrogen chambers. In one end cap, a hydraulic fitting is used to attach the fluid chamber to the hydraulic system. In the other end cap, an air filler valve provides a connection to an air/nitrogen source. In operation, the compressed gas chamber is charged to a pressure that is something less than the system operating pressure. This initial charge is called the *accumulator preload*.

Assume that the cylinder-type accumulator pictured in figure 8-35 is designed for a nitrogen gas preload of 700 psi in a 1,500-psi hydraulic system. When the initial charge of 700 psi is introduced into the unit, hydraulic system pressure is zero. As nitrogen pressure increases, the piston is pushed toward the opposite end until it bottoms. Then, with the nitrogen at 700 psi, the pressure in the hydraulic system must be increased to something greater than 700 psi before the hydraulic fluid can actuate the piston. Thus, at 701 psi in the system, the pressure begins to move the piston back toward the gas end of the cylinder, compressing the nitrogen as it moves. At 900 psi, the piston will have moved several inches. At 1,500 psi, the piston will have moved back to its normal operating position, compressing the nitrogen until it occupies a space less than one-half the length of the cylinder. Then, when actuation of a hydraulic unit lowers the pressure in the system, the compressed nitrogen expands against the piston, forcing fluid from the accumulator, providing an instantaneous supply of fluid to the hydraulic system.

ACTUATORS (ACTUATING CYLINDERS)

An actuator is a device that transforms fluid pressure into mechanical force to move some mechanism. For example, a hydraulic motor is an actuator that converts fluid under pressure into rotary motion.

The most common actuator used in support equipment is the actuating cylinder. This actuator converts fluid under pressure into linear or reciprocating mechanical motion. There are two main types—the single-action actuating cylinder and the double-action actuating cylinder.

NOTE: You will find the terms *piston* and *ram* both used when referring to the movable elements of actuating cylinders. The term *ram* is normally associated with movable elements that have no piston rods and are used primarily for push functions. (The piston and rod usually are approximately the same diameter.) Movable elements that are attached to piston rods and are used for both push and pull functions are called *pistons*.

Single-Acting Actuating Cylinders

Single-acting actuating cylinders are designed to allow piston (ram or shaft) travel in one direction through the use of fluid under pressure. Piston travel in the opposite direction is provided by some other force, usually gravity (weight). For example, in the actuating cylinders of hydraulic jacks, workstands, and some models of forklifts, hydraulic fluid provides the force to raise the rams, and the weight of the ram and the load lowers the ram.

Three examples of single-acting actuating cylinders are shown in figure 8-36. Figure 8-36, view A shows a single ram cylinder. This type of cylinder is used in hydraulically operated workstands and as the lift cylinder on some models of forklifts. Fluid is forced into the bottom of the cylinder to extend the ram. Then, to retract (lower) the ram, fluid is allowed to flow out of the cylinder to the reservoir. The weight of the ram and any load that it might carry forces the ram to retract into the cylinder.

A telescoping ram cylinder assembly is shown in view B of figure 8-36. This type of actuating cylinder is used in some hydraulic jacks, and operates much like a single ram cylinder. Fluid is forced into the bottom of the cylinder to extend the rams. Since the fluid pressure acts on the entire cross-sectional area of ram 1, this ram extends first. When the lip of ram 1

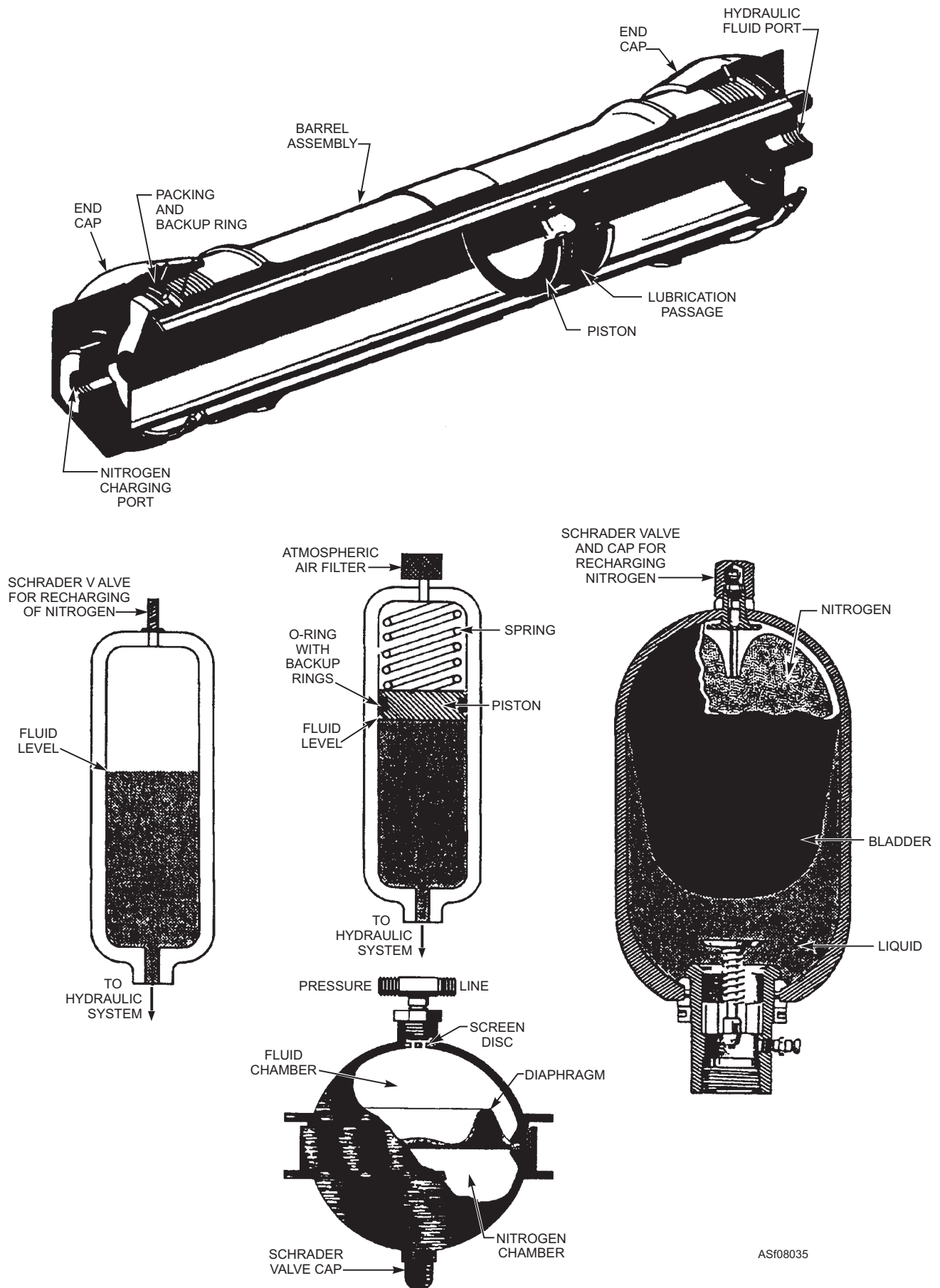

ASF08035

Figure 8-35.—Typical accumulators.

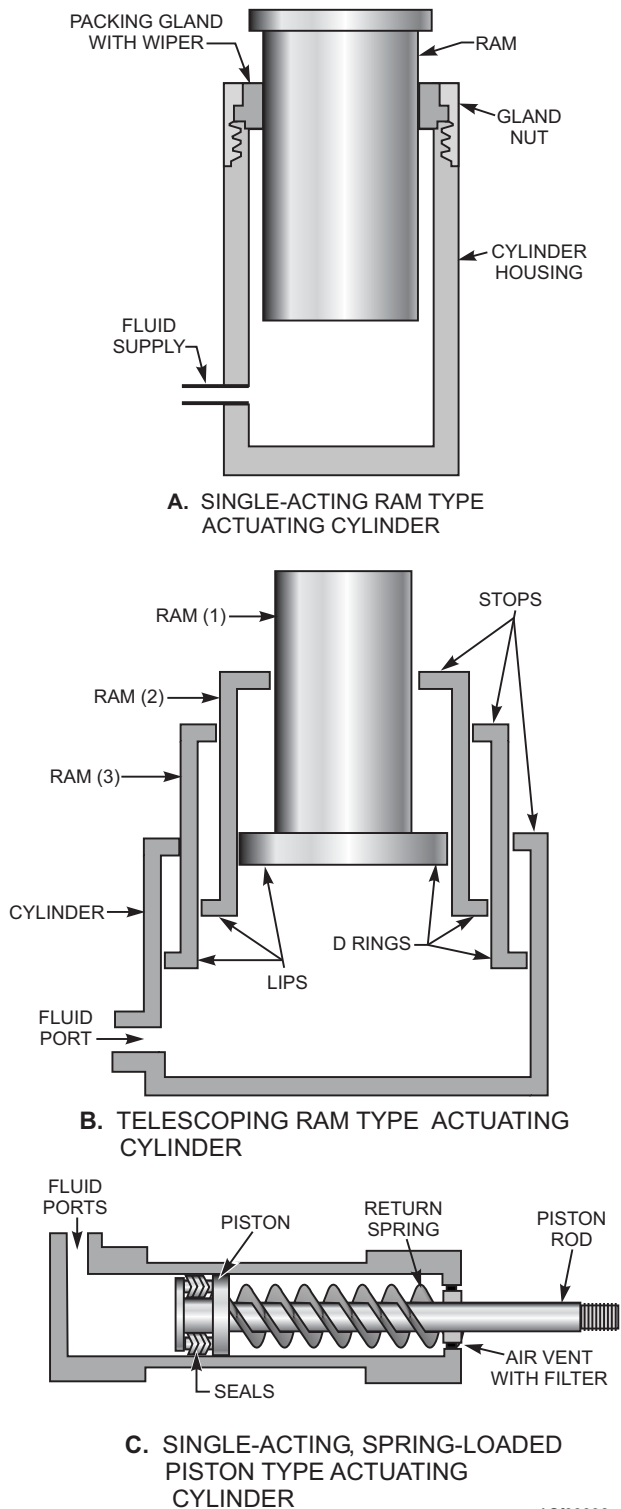

Figure 8-36.—Single-acting actuating cylinders.

AS108036

strikes the stop of ram 2, ram 2 extends. This action continues until the desired extension is reached, or until the lip of ram 3 strikes the stop of the cylinder.

A spring-loaded cylinder, like that shown in view C of figure 8-36, is used in devices where gravity or the weight of the load will not return the ram to a fully retracted position.

Double-Acting Actuating Cylinders

A typical double-acting actuating cylinder is shown in figure 8-37, view A. This type of cylinder operates under the influence of fluid flow in either direction. The cylinder contains one piston and piston rod assembly. The two fluid ports, one near each end of the cylinder, alternate as inlet and outlet ports, depending on the direction of flow from the directional control valve.

Figure 8-37, view B, shows an unbalanced actuating cylinder. That is, there is a difference in the effective working areas on the two sides of the piston. Fluid pressure acts on the entire area taken up by the blank side of the piston (in the figure, the blank side is the area at the bottom of the cylinder). On the other side of the piston, the rod side, fluid pressure acts on a smaller area. For this reason, this type of actuating cylinder is normally installed in such a way that the blank side of the piston carries the greater load. That is, the cylinder carries the greater load during the extension stroke.

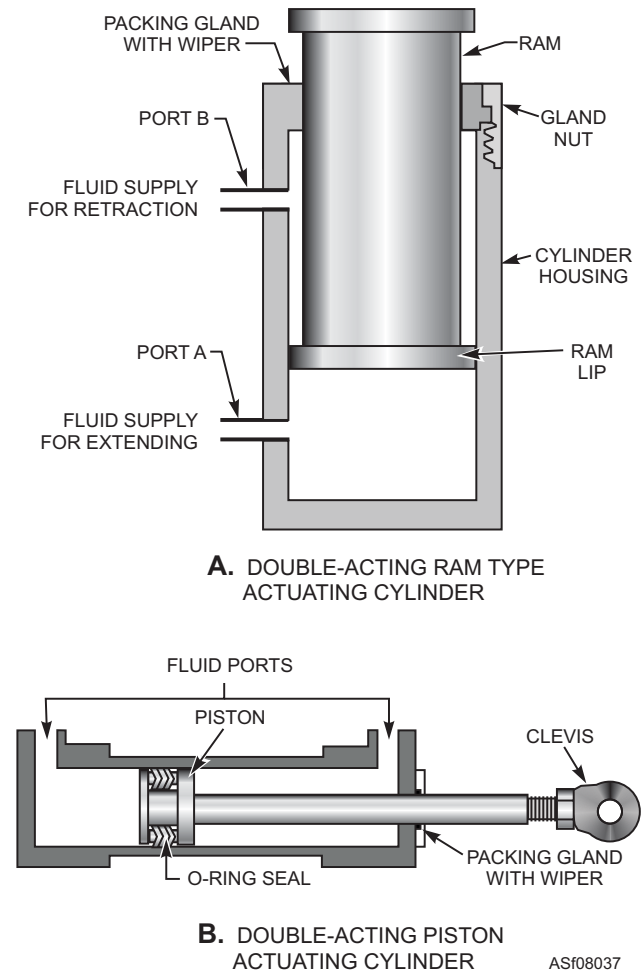

Figure 8-37.—Typical cross-sectional view of a double-acting actuating cylinder.

AS108037

To see how it works, you need to apply some pressure to the double-acting cylinder shown in figure 8-37, view B. The stroke of the piston and piston rod assembly in either direction is produced by fluid pressure. Assume that the cross-sectional area of the piston is 3 square inches and the cross-sectional area of the rod is 1 square inch. In a 2,000-psi system, pressure acting against the blank side of the piston creates a force of 6,000 pounds ($2,000 \text{ psi} \times 3 \text{ in.}^2$). When the pressure is applied to the rod side of the piston, the 2,000 psi acts on 2 square inches (the cross-sectional area of the piston less the cross-sectional area of the rod) and creates a force of 4,000 pounds ($2,000 \text{ psi} \times 2 \text{ in.}^2$). As noted earlier, double-acting cylinders are normally used in such a way that the blank side of the piston carries the greater load. That is, the cylinder carries the greater load during the piston rod extension stroke, which may be required to lift a heavy load, but when the piston rod is retracted, gravity helps make up loss of force caused by a smaller surface area. This same cylinder can be used to operate the side shift on a forklift where the working load is not as important as the ability to move the load from side to side.

A four-way directional control valve is normally used to control the operation of this type of cylinder. The valve can be positioned to direct fluid under pressure to either end of the cylinder, and to allow the displaced fluid to flow from the opposite end of the cylinder through the control valve to return the hydraulic fluid to the reservoir.

PRESSURE GAUGES

Pressure gauges installed in hydraulic systems are used to indicate existing pressures. Most gauges used

in the fluid power systems of support equipment are the direct reading type. That is, the gauge is connected directly into the unit or lines leading to the unit and becomes part of the container or system. The gauge is able to sample the existing pressure at its location in the system.

The Bourdon Tube

The main part of a pressure gauge is the Bourdon tube (fig. 8-38). It is a curved metal tube that is oval in cross-sectional shape. One end of the tube is closed; the other end has a fitting for connecting it to a pressure source. The fitting end is fastened to the frame of the gauge frame, while the other end is free to move so it can operate the mechanical linkage.

Assume that fluid pressure enters the Bourdon tube. Since fluid pressure will be transmitted equally in all directions and the area on the outside radius of the tube is greater than that of its inside, the force will also be greater on the outside radius, which tends to straighten out the tube. As the movable end of the tube tries to turn outward, it turns the pivot segment gear. This gear meshes with a smaller rotary gear to which a pointer is attached, and its movement causes a reading on the pressure gauge. The gauge dial is calibrated so the needle points to a number that corresponds to the exact pressure that is applied. When the pressure is removed, the Bourdon tube acts as a spring and returns to its normal position.

Pressure gauges are designed to indicate different ranges of pressure in pounds per square inch. In support equipment, these gauges may range from 0 to 100 psi, or up to 6,000 psi or greater. Figure 8-39 shows

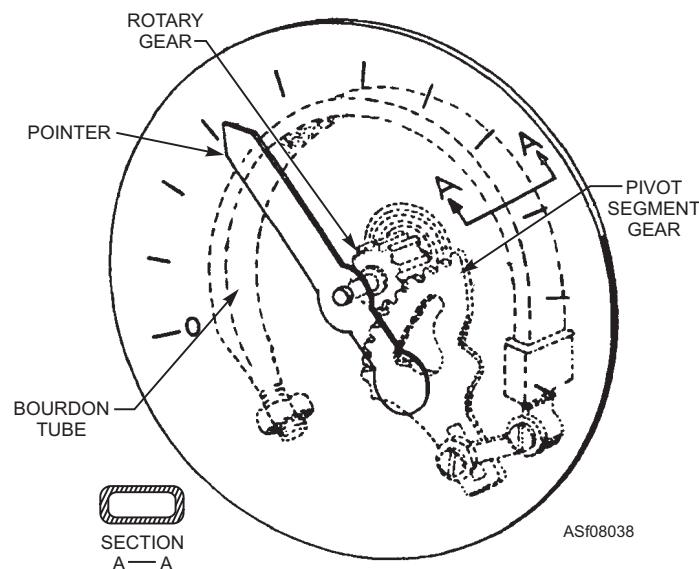

Figure 8-38.—Bourdon tube.

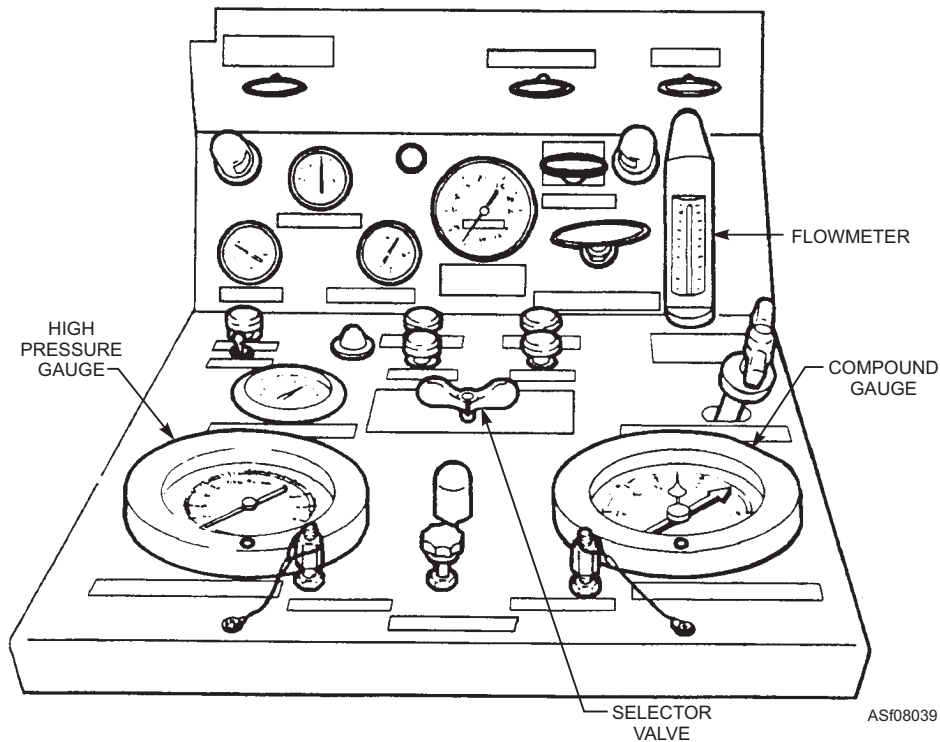

Figure 8-39.—A/M27T-5 control panel, controls, instruments, and gauges.

the control panel of the A/M27T-5 hydraulic test stand. Note that the panel shows a variety of gauges. The large gauge on the left of the panel (1) is an example of a 0 to 6,000 psi hydraulic pressure gauge.

Compound Gauges

Compound gauges in hydraulic systems are used to indicate pressure or suction in the system. They normally indicate vacuum from 0 to 30 inches of mercury (in.Hg) and pressure from 0 to 300 psi. The compound gauge shown in figure 8-39 (2) is used in conjunction with the directional valves (3) to indicate back pressure or suction in the return line, the inlet to the low-pressure pump, or the inlet to the high-pressure pump.

Defective gauges are removed and replaced with good ones. Defective gauges are then turned in to the AIMD calibration lab for repair or to be condemned and deleted from the calibration inventory.

Flowmeters

Flowmeters are used in hydraulic power supplies and component test benches to indicate the rate of flow of fluids, usually in gallons per minute (fig. 8-39). One use of a flowmeter, for example, is in testing the output of pumps. The most common type of flowmeter used is the rotameter, which is described in *Fluid Power*, NAVEDTRA 14105.

Pressure Gauge Snubbers

A pressure gauge snubber (fig. 8-40) is a hydraulic component that is located upstream of a pressure gauge. Its function is to dampen out system pressure surges that could cause damage to a gauge. Without a snubber, pressure oscillations and sudden pressure changes could affect the delicate internal mechanism of a gauge. Also, by removing oscillations, it makes a gauge easier to read.

The basic components of a snubber are the housing, fitting assembly (with a fixed orifice), and the pin and plunger assembly. The snubbing action is obtained by metering fluid through the snubber. The fitting assembly orifice restricts the amount of fluid that flows to the gauge, thereby snubbing the force of a pressure surge. The pin is pushed and pulled through the orifice of the fitting assembly by the plunger, keeping it clear and at uniform size.

Calibration of Gauges

If a pressure gauge is not functioning properly, it could lead to damage to the system it monitors. It could also be a safety hazard to personnel. For this reason, NAVAIRSYSCOM requires that pressure gauges used to service tires, shock struts, and hydraulic accumulators be calibrated every 30 days. On servicing equipment with multiple-gauge installations, only the gauge or gauges that monitor the

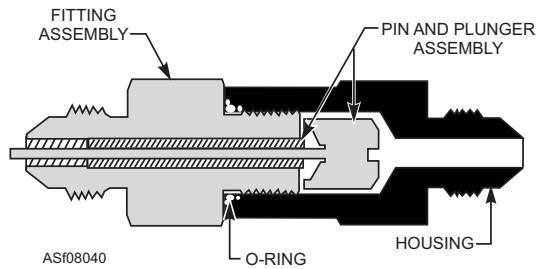

Figure 8-40.—Pressure gauge snubber.

pressure being applied directly to the system being serviced must be calibrated every 30 days. The *Metrology Requirements List* (METRL), NAVAIR 17-35MTL-1, is the authoritative reference for requirements for calibration of all gauges. It lists equipment and gauges by part number and/or model number and prescribes the intervals of calibration.

Q8-3. Which of the following components serves as a source of fluid supply, dissipates heat, traps foreign particles, and separates air from the fluid?

1. A reservoir
2. A pump
3. An accumulator
4. An actuator

Q8-4. A pump that is manually operated is referred to as what type of pump?

1. Full-flow pump
2. Single-action pump
3. Hand pump
4. Closed-loop pump

Q8-5. The terms fixed displacement and variable displacement are used to classify pumps?

1. True
2. False

Q8-6. Which of the following abbreviations normally expresses the volume output of a pump?

1. Rpm
2. Psi
3. Emf
4. Gpm

Q8-7. Gears, lobes, and vanes are commonly used as elements in which of the following types of pumps?

1. Spur tooth pumps
2. Rotary pumps
3. Lobe pumps
4. Internal gear pumps

Q8-8. Which of the following pumps is the most commonly used pump in support equipment?

1. Hand pumps
2. Vane pumps
3. Reciprocating pumps
4. Closed-center pumps

Q8-9. A micron-type filter element is made from which of the following types of materials?

1. A cellulose paper
2. A wire mesh
3. A carbon fiber
4. A poly/cotton fiber

Q8-10. What type of filtration does all aircraft hydraulic servicing and test equipment use in fluid discharge or output pressure lines?

1. A 5-micron full-flow filter
2. A 5-micron non-bypass filter
3. A 3-micron full flow filter
4. A 3-micron non-bypass filter

Q8-11. Which of the following values provides protection against overloading of hydraulic components?

1. A check valve
2. A relief valve
3. A bypass valve
4. An actuator valve

Q8-12. Which of the following types of directional valves uses a hand lever or a knob to move the core inside the stationary sleeve?

1. A poppet valve
2. A sliding valve
3. A rotary spool valve
4. A plunger valve

Q8-13. Which of the following statements is NOT true concerning an accumulator?

1. An accumulator can act as a cushion against pressure surges
2. In the event of normal hydraulic system failure, the energy stored in the accumulator can be used to actuate a unit of the system
3. An accumulator can supplement the pumps output when the pump is under peak load
4. An accumulator can be used as a reservoir if the hydraulic system is overserviced

Q8-14. Which of the following components is designed to dampen out system pressure surges that could cause damage to a gauge?

1. A snubber
2. A filter
3. A restrictor
4. A diaphragm

Q8-15. Which of the following publications is the authoritative reference for the calibration of all gauges?

1. NAVAIR 4790.2
2. NAVAIR 17-35MTL-1
3. NAVAIR 17-15BAD-1
4. NAVAIR 17-45CAL-1

HYDRAULIC MOTORS

A fluid power motor is a device that converts fluid power to rotary motion and force. Even though the function of a motor is just the opposite of that of a pump, the design and operation of fluid power motors and pumps are very similar. In fact, some hydraulic pumps can be used as motors with little or no modification. For this reason, information about pumps given earlier in this chapter will help you understand the operation of fluid power motors.

Motors serve many applications in fluid power systems. In hydraulic power drives, pumps and motors are combined with suitable lines and valves to form hydraulic transmissions. The pump, commonly called the A-end, is driven by an outside source of power, such as an electric motor. The function of the pump is to deliver fluid to the motor. The motor, called the B-end, is actuated by the flow of fluid, and through mechanical linkage, it conveys rotary motion and force to the work.

Fluid motors are usually classified according to the type of internal element that is directly actuated by the flow. The most common types of elements are gears and pistons. Both types are adaptable for hydraulic systems.

Gear-Type Motors

The gears of a gear-type motor are of the external type and may be spur, helical, or herringbone design. These designs are the same as those used in gear pumps.

The operation of a gear-type motor is illustrated in figure 8-41. Both gears in the figure are driven.

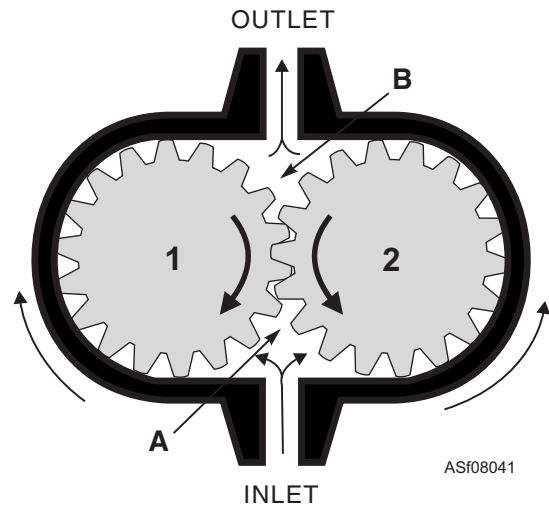

Figure 8-41.—Gear-type motor.

However, only one gear is connected to the output shaft. As fluid under pressure enters chamber A, it takes the path of least resistance and flows around the inside surface of the housing, forcing the gears to rotate as indicated. The flow continues through the outlet port to the return. This rotary motion of the gears is conveyed through an attached shaft to the work unit.

Although the motor illustrated in figure 8-41 shows operation in only one direction, a gear-type motor is capable of providing rotary motion in either direction. For this to happen, the ports must alternate as inlet and outlet. Thus, to reverse the direction of rotation, fluid is directed through the port labeled outlet into chamber B. The flow through the motor then rotates the gears in the opposite direction of that shown in the figure, actuating the work unit accordingly.

Piston-Type Motors

Like piston-type (reciprocating) pumps, the most common design of piston-type motors is the axial. This type of motor is most commonly used in hydraulic systems. (See figure 8-42.)

Although some piston-type motors are controlled by directional control valves, they are

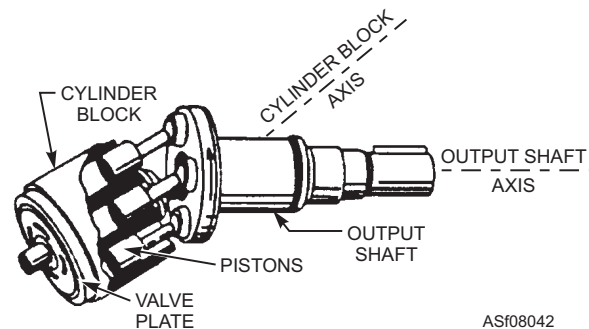

Figure 8-42.—Piston-type motor.

often used in combination with variable displacement pumps. This pump-motor combination (hydraulic transmission) is used to provide a transfer of power between a driving element (for example, an electric motor or gasoline engine) and a driven element. Some of the applications for which hydraulic transmissions may be used are speed reducers, variable speed drives, constant speed or constant torque drives, and torque converters. Some advantages of hydraulic transmission of power over mechanical transmission of power are as follows:

- Quick, easy speed adjustment over a wide range while the power source is operating at constant (most efficient) speed. Rapid, smooth acceleration or deceleration.
- Control over maximum torque and power.
- Cushioning effect to reduce shock loads.
- Smoother reversal of motion.

You may find it useful to refer back to the piston-type pump shown in figure 8-17 to review its operation and component parts.

The operation of the axial piston motor shown in figure 8-42 is similar to that of an axial piston pump. Fluid from the system flows through one of the ports in the valve plate and enters the bores of the cylinder block that are open to the inlet port. The fluid acting on the pistons in those bores forces the pistons to move away from the valve plate. Since the pistons are held by connecting rods at a fixed distance from the output shaft flange, they can move away from the valve plate only by moving in a rotary direction. This causes the drive shaft and cylinder block to rotate. While some of the pistons are being driven by liquid flow from the system, others are discharging flow from the outlet port.

This type of motor may be operated in either direction of rotation. The direction of rotation is controlled by the direction of flow to the valve plate. The direction of flow may be instantly reversed without damage to the motor.

The speed of rotation of the motor is controlled by the length of the piston stroke in the pump. When the pump is set to allow a full stroke of each piston, each piston of the motor must move an equal distance. In this condition, the speed of the motor equals that of the pump. However, if the tilting plate of the pump (sometimes called a *swashplate* or *hanger assembly*) is changed so that the piston stroke

of the pump is only half as long as the stroke of the motor, it will require two full strokes of the discharge piston to produce one full stroke of the motor. In this position of the plate, the motor will revolve only half as fast as the pump. If there is no angle on the pump's tilting plate, the pumping pistons will not move axially, and liquid will not be delivered to the motor. Thus, the motor will not deliver power.

If the angle of the tilting plate is reversed, the direction of flow is reversed. Then, liquid enters the motor through the port by which it was formally discharged, reversing the direction of rotation of the motor.

An additional benefit to this axial piston pump/axial piston motor configuration is the dynamic braking effect created when the motor, in a coasting situation, in effect, becomes a pump itself and attempts to reverse-rotate the hydraulic pump. The pump then becomes a motor and attempts to reverse-rotate the prime mover. The degree of reverse angle on the tilting plate in the pump determines the effectiveness of the dynamic braking effect. This type of drive motor is used in the propulsion systems of A/S32A-32 tow tractors (spotting dollies).

Detailed descriptions and illustrations of different types of hydraulic motors can be found in *Fluid Power*, NAVEDTRA 14105.

Q8-16. The most common type of elements found in a hydraulic motor is gears and pistons?

1. True
2. False

Q8-17. What is the most common type of motor used in a hydraulic system?

1. A gear type
2. A spur type
3. A piston type
4. A vein type

HYDRAULIC SYSTEMS

LEARNING OBJECTIVE: Identify the components of a hydraulic system.

In spite of the great variety of support equipment, all hydraulic systems, from the simplest to the most complex, operate according to basic principles.

As an AS, you are responsible for analyzing the malfunctions of hydraulic equipment ranging from the

simple jack to the A/S32A-32 shipboard towing tractor. Thus, the discussion, piece by piece, of a representative system should assist you in analyzing any other hydraulic system.

REPRESENTATIVE HYDRAULIC SYSTEM

Basically, any hydraulic system must contain the following elements: a pump, an actuator, a reservoir, a control valve, and tubing. Figure 8-43 shows a simple system that uses only these essentials.

The flow of hydraulic fluid can be easily traced from the reservoir through the pump to the directional valve. With the directional valve in the position indicated by the solid lines, the flow of fluid created by the pump flows through the valve to the upper end of an actuating cylinder. Fluid pressure then forces the piston down, and at the same time, forces out the fluid on the lower side of the piston, up through the directional valve, and back to the reservoir.

When the directional valve is rotated 90 degrees, the fluid from the pump flows to the lower side of the actuating cylinder, thus reversing the process. The movement of the piston can be stopped at any time simply by moving the directional valve to the neutral position (45-degree movement either way). In this position, all four ports are closed and pressure is trapped in both working lines.

This hydraulic system would be practical if it were operated by a hand pump, such as a system common to engine installation/removal stands and bomb trucks. However, as the pump shown in figure 8-43 is a power-driven, constant delivery gear pump, pressure builds up immediately to such proportions that either

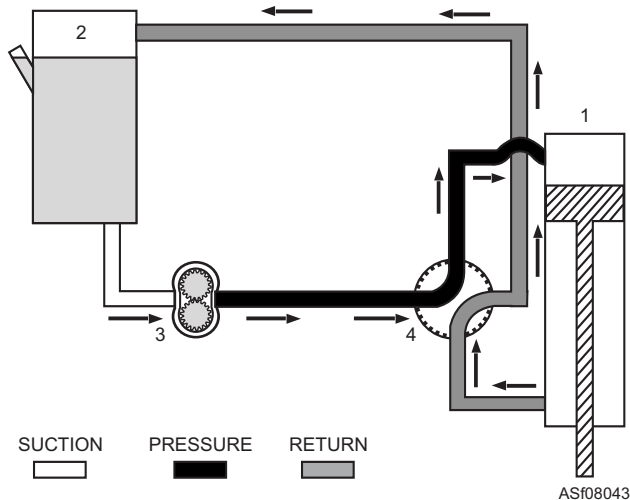

Figure 8-43.—Simple hydraulic system.

the pump fails or a line bursts. To keep this from happening, a pressure-relief valve is added to the system, as shown in figure 8-44. This valve is set to relieve system pressure before it becomes high enough to rupture the system or damage the pump. The relief valve ball is unseated at a predetermined pressure, and excess fluid is bypassed to the reservoir.

Although the system shown in figure 8-44 is workable, it is still impractical. After a few hours, an ordinary pump would probably fail because it has to maintain a constant load. (The pump is keeping the relief valve unseated except when the cylinder is being moved.) With the addition of a check valve and pressure regulator (fig. 8-45), the workload on the pump is relieved, and the system is more efficient, safer, and more durable. (A variable displacement pump with its own built-in pressure control serves the same purpose in a system as the pressure regulator valve in this system.) The pressure regulator maintains system pressure between two predetermined pressure limits and relieves the pump when no mechanisms are moving, bypassing the pump flow unrestricted back to the reservoir. By adding the regulator valve to the system, the relief valve becomes a safety valve, used to prevent system damage in case of regulator or variable displacement pump control failure.

The system shown in figure 8-45 is a practical, workable system. However, more complex equipments normally use additional components to increase efficiency, safety, and emergency or standby operation.

A complete hydraulic system is shown in figure 8-46. In addition to the components already

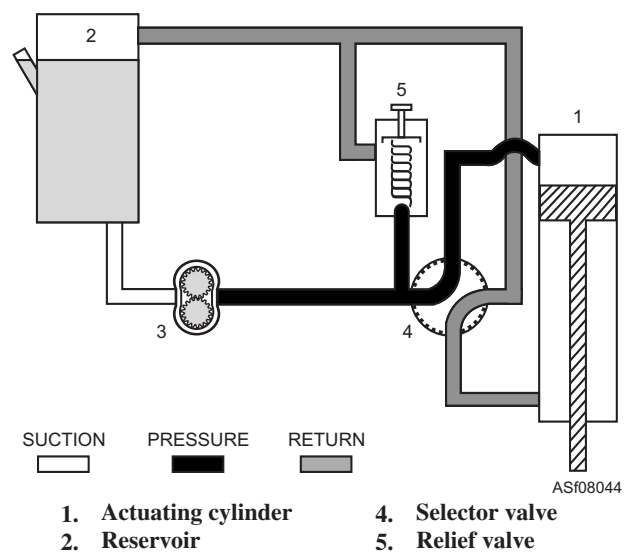

Figure 8-44.—Hydraulic system with a relief valve incorporated.

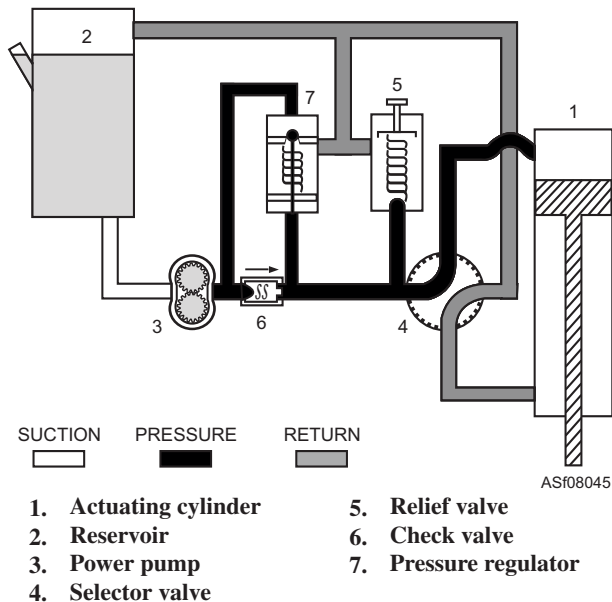

Figure 8-45.—Hydraulic system with a relief valve and regulator incorporated.

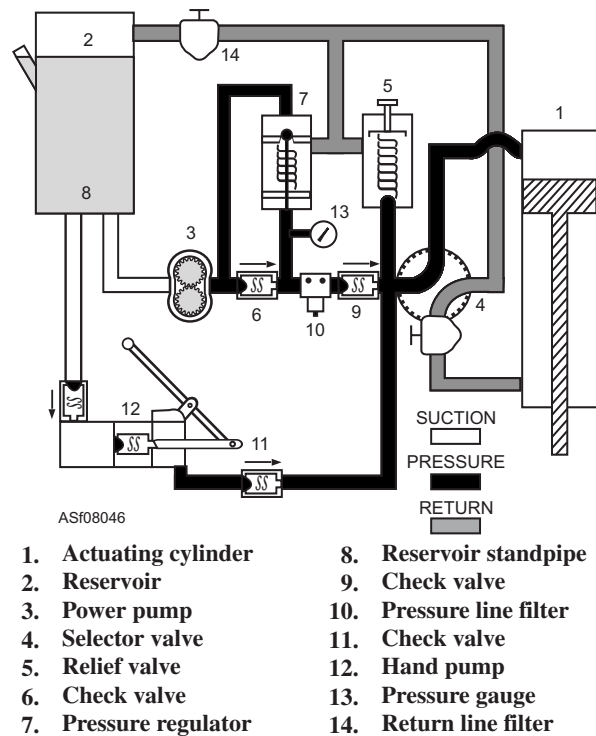

Figure 8-46.—Complete hydraulic system.

mentioned, this system includes more check valves, a pressure gauge, filters, and a hand pump. The hand pump is added as an auxiliary system, normally used as an emergency power source in case of failure of the main power pump.

The complete hydraulic system may be further expanded by including a pressure manifold, more selector valves, actuating mechanisms, and more power-driven pumps connected in parallel. But, you

should remember that all systems can be broken down into a simplified system (as shown in figures 8-43 through 8-46). Thus, even the most complex system can be analyzed, not from the standpoint of a complex system but from that of a simple system.

TYPES OF HYDRAULIC SYSTEMS

There are two types of hydraulic systems used in support equipment, open-center and closed-center.

Open-Center System

An open-center system is one that has fluid flow but no pressure in the system whenever the actuating mechanisms are idle. Fluid circulates from the reservoir, through the pump, through the directional valves, and back to the reservoir. Pressure developed in an open-center system is controlled by open-center Directional valves and is limited by a system relief valve. Figure 8-47 shows an open-center system. Note the position of the directional valves and the fact that the valves are connected in series. In this type of system, there is no pressure in the system until one of the subsystems is actuated by the positioning of the directional valve. When in the neutral position (view A), the open-center directional valve directs the fluid to the return line. When the directional valve is positioned out of neutral, pressure builds up in the actuating section and operates the selected mechanism (view B). When an open-center system is not being used (no actuating mechanisms), the pump is said to be idling because there is no pressure buildup in the system. Therefore, there is no load on the pump. Fixed displacement pumps are used in open-center systems and normally do not require a pressure regulator.

Closed-Center System

A closed-center system always has fluid stored under pressure whenever the pump is operating. However, when pressure is built up to a predetermined value, the load is automatically removed from the pump by a pressure regulator or the integral control valve of the variable displacement pump. The hydraulic system shown in figure 8-46 is a closed-center system. In a closed-center system, multiple Directional valves are arranged in parallel rather than in series, as in an open-center system.

NOTE: Some systems may employ both open-center and closed-center features.

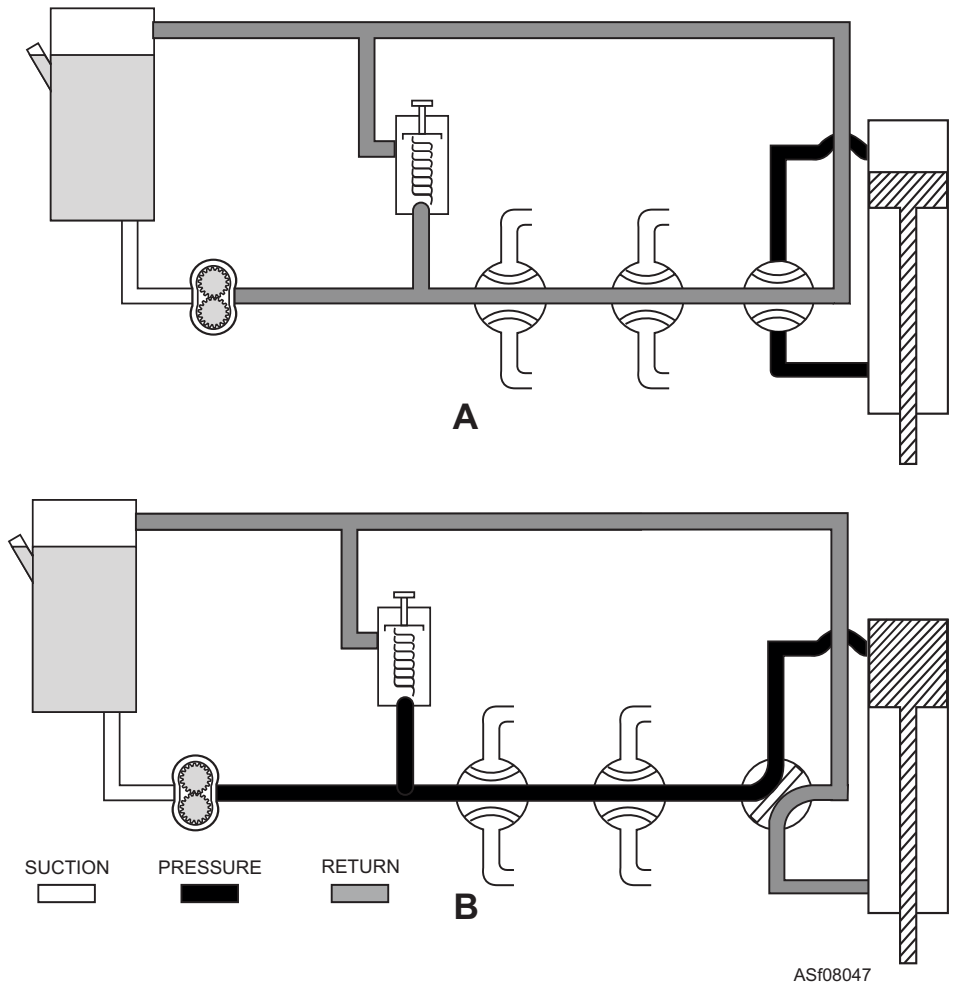

Figure 8-47.—Basic open-center system.

Q8-18. What type of hydraulic system has fluid flow but no pressure in the system whenever the actuating mechanisms are idle?

1. A full-flow system
2. A free-flow system
3. A open-center system
4. A closed-center system

Q8-19. Which of the following systems has multiple directional valves arranged in parallel rather than in series?

1. A full-flow system
2. A free-flow system
3. A open-center system
4. A closed-center system

HYDRAULIC SYSTEM CONTAMINATION

LEARNING OBJECTIVES: Identify classes of contamination in hydraulic systems. Identify tests for detection of contamination in

hydraulic systems. Identify procedures for decontamination of hydraulic systems.

Contamination is the direct or indirect cause of more hydraulic system failures than any other single source. For this reason, contamination prevention is a major concern for all who operate and maintain hydraulic systems. Contamination in hydraulic systems of support equipment not only causes malfunctions in the equipment but in aircraft as well. A small mistake that leads to contamination can result in enormous damages. For example, consider the case of a hydraulic check and fill stand or a portable hydraulic power supply that has contaminated fluid. If these are used to service aircraft, the result can be damage to expensive equipment, loss of an aircraft costing millions of dollars, or even injury to or loss of life of personnel.

The *Aviation Hydraulics Manual*, NAVAIR 01-1A-17, and the *Aviation Hose and Tube Manual*, NAVAIR 01-1A-20, are excellent publications on the subject of contamination. These manuals are required

reading for all personnel who use and maintain aircraft hydraulic servicing equipment.

CLASSES OF CONTAMINATION

The two general contamination classes are as follows:

- Abrasive. This includes such particles as dust, dirt, core sand, weld spatter, machining chips, and rust.
- Nonabrasive. This includes things that result from oil oxidation and soft particles worn or shredded from seals and other organic components.

The mechanics of the destructive action by abrasive contaminants is clear. When the size of the particles circulating in the hydraulic system is greater than the clearance between moving parts, the clearance openings act as filters and retain such particles. Hydraulic pressure then embeds these particles into the softer materials. The reciprocating or rotating motion of component parts develops scratches on finely finished surfaces, ultimately resulting in increased tolerances and decreased efficiency.

Oil-oxidation products, usually called *sludge*, have no abrasive properties. Nevertheless, sludge may prevent proper functioning of a hydraulic system by clogging valves, orifices, and filters. Frequent changing of hydraulic system fluid is not a satisfactory solution to the contamination problem. Abrasive particles contained in the system are not usually flushed out, and new particles are continually created as friction products. Furthermore, every minute remnant of sludge acts as an effective catalyst to speed up oxidation of the fresh fluid. (A catalyst is a substance that, when added to another substance, speeds up or slows down chemical reaction, but is itself unchanged at the end of the reaction.)

ORIGIN OF CONTAMINANTS

The origin of contaminants in hydraulic systems can be traced to the following areas:

- **PARTICLES ORIGINALLY CONTAINED IN THE SYSTEM.** These particles originate during fabrication of welded system components, especially in reservoirs and pipe assemblies. The presence is minimized by proper design. For example, seam-welded overlapping joints are preferred; arc welding of open sections is usually avoided. Hidden passages in valve bodies, inaccessible to sand blasting,

are the main source of core sand entering the system. Even the most carefully designed and cleaned casting occasionally frees some sand particles under the action of hydraulic pressure. Rubber hose assemblies always contain some loose particles, most of which can be removed by flushing; others withstand cleaning and are freed later by the action of hydraulic pressure and heat.

Rust or corrosion initially present in a hydraulic system can usually be traced to improper storage of replacement materials and component parts. Particles can range in size from large flakes to abrasives of microscopic dimensions (remember the discussion earlier on the size of a single micron). Proper preservation of stored parts is helpful in eliminating corrosion.

- **PARTICLES OF LINT FROM CLEANING MATERIALS.** These can cause abrasive damage in hydraulic systems, especially to closely fitted moving parts. In addition, lint in a hydraulic system packs easily into clearances between packing and contacting surfaces, leading to component leakage and decreased efficiency. Lint also helps clog filters prematurely.

- **PARTICLES INTRODUCED FROM OUTSIDE FORCES.** Particles can be introduced into hydraulic systems at points where either the fluid or certain working parts of the system (e.g., piston rods) are at least in temporary contact with the atmosphere. The most common danger areas are at the refill and breather openings and at cylinder rod packing. Contamination arising from carelessness during servicing operations is minimized by the use of an approved dispensing cart employing proper filters, and filler strainers in the filling adapters of hydraulic reservoirs. Hydraulic cylinder piston rods use wiper rings and dust seals to prevent the dust that settles on the piston rod during its outward stroke from being drawn into the system when the piston rod retracts. Similarly, single-acting actuating cylinders use an air filter in the vent to prevent ingestion of airborne contamination during the return stroke (refer back to view C of figure 8-36).

- **PARTICLES CREATED WITHIN THE SYSTEM DURING OPERATION.** Contaminants created during system operation are of two general types—mechanical and chemical. Particles of a mechanical nature are formed by wearing of parts in frictional contact, such as pumps, cylinders, and packing gland components. Additionally, over-age hydraulic hose assemblies tend to break down inside and contaminate the system. For this reason, hoses are

marked with “forced removal” dates in accordance with NAVAIR 01-17-1A. These particles can vary from large chunks of packing and hose material down to steel shavings of microscopic dimensions that are beyond the retention potential of system filters.

The chief source of chemical contaminants in hydraulic fluid is oxidation. These contaminants are formed under high pressure and temperatures and are promoted by the catalytic action of water and air and of metals like copper or iron oxides. Oil-oxidation products appear initially as organic acids, gums, and varnishes—sometimes combined with dust particles as sludge. Fluid soluble oxidation products tend to increase fluid viscosity, while insoluble types form sediments and precipitates, especially on colder elements such as heat exchanger coils.

Fluids containing antioxidants have little tendency to form gums under normal operating conditions. However, as the temperature increases, resistance to oxidation diminishes. Hydraulic fluids that have been subjected to excessively high temperatures (above 250°F) break down in substance, leaving minute particles suspended in the fluids. The fluid changes to brown in color and is called *decomposed fluid*. This explains the importance of keeping the hydraulic fluid temperature below specified levels.

The second contaminant producing chemical action in hydraulic fluids is one that permits these fluids to establish a tendency to react with certain types of rubber. This causes structural changes in the rubber, turning it brittle, and finally causing its complete disintegration. For this reason, the compatibility of system fluid with seals and hose material is a very important factor.

• **PARTICLES INTRODUCED BY FOREIGN FLUIDS.** One of the most common foreign-fluid contaminants is water, especially in hydraulic systems that require petroleum-based fluids. Water, which enters even the most carefully designed systems by condensation of atmospheric moisture, normally settles to the reservoir bottom. Fluid movement in the reservoir disperses the water into fine droplets; agitation of the fluid in the pump and in high-speed passages forms an oil-water-air emulsion. Such an emulsion normally separates out during the rest period in the system reservoir; but when fine dust and corrosion particles are present, the emulsion is catalyzed by high pressures into sludge. The damaging action of sludge explains the need for water separating qualities in hydraulic fluids.

CONTAMINATION CONTROL

Filters provide adequate control of the contamination problem during all normal hydraulic system operations. Control of the size and amount of contamination entering the system from any other source must be the responsibility of the personnel who service and maintain the equipment. Therefore, precautions must be taken to ensure that contamination is held to an absolute minimum during servicing. Remove and clean or replace the filter element before a system becomes excessively contaminated.

As an aid to exercising contamination control, adhere at all times to the following maintenance and servicing procedures:

- Maintain all tools and work areas (work benches and test equipment) in a clean, dirt-free condition.
- Open hydraulic systems only when necessary.
- Before removing or installing a component, make sure the unit is clean and the fittings have been wiped down.
- Do not drain and reuse hydraulic fluid.
- Before removing a defective component, have a replacement available (to minimize the amount of time you must leave the system open).
- Recap tubing, hoses, fittings, and components immediately after opening.
- Ensure all internal and external hose assemblies are properly annotated with applicable data as required by the *Aviation Hose and Tube Manual*.
- Ensure all internal and external hose assemblies are monitored to comply with forced removal date (FRD) requirements.
- Use metal caps on male fittings; metal plugs in female fittings.
- Replace filter elements immediately after removing; if this is not possible, place a protective covering over the opening.
- Before installing filters, fill filter bowl with the correct hydraulic fluid (this reduces air in the system).
- If a hydraulic filter warning light is on, do not operate the equipment.
- Service hydraulic reservoirs with an approved dispenser, providing the proper micron filtering.

- Use the correct hydraulic fluids, lubricants, and O-rings.
- Practice proper O-ring installation techniques.
- Ensure that hydraulic fluid containers are clean before opening.
- Always dispose of unused hydraulic fluid remaining in an opened container.
- Use the proper tools for the job.
- Before assembling hydraulic components, wash all parts in an approved dry-cleaning solution.
- After cleaning parts in dry-cleaning solution, dry the parts thoroughly and lubricate with the recommended preservative or hydraulic fluid before reassembly.

NOTE: Use only clean, lint-free cloths to wipe and dry component parts.

- Replace all seals and gaskets during the reassembly procedure.
- Connect all parts with care to avoid stripping metal slivers from threaded areas. Install and torque all fittings and lines in accordance with applicable technical instructions.
- Keep all hydraulic servicing equipment clean, in good operating condition, and protected from the weather.

CONTAMINATION CHECKS

If a hydraulic system is known to have been contaminated by an external source and there is no damage to the system, simply flush the system to take care of the problem. Often, however, the problem is more complex and may require checks to determine exactly what the problem is or to locate a component that is contaminating the system.

Fluid Sampling

Whenever you suspect that a hydraulic system is excessively contaminated, or when the system operates at temperatures in excess of the specified maximum, you must make a check of the system. The filters in most hydraulic systems are designed to remove most foreign particles that are visible to the naked eye. However, visual inspection of hydraulic fluid may not suffice to determine the level of contamination, and hydraulic fluid that appears clean

to the naked eye may be contaminated to the point that it is unfit for use.

Large particles of impurities in a hydraulic system indicate that one or more components in the system are being subjected to excessive wear. Isolating the defective components requires a systematic process of elimination. Fluid returning to the reservoir may contain impurities from any part of the system. In order to determine which component is defective, take fluid samples from the reservoir and various other locations in the system, including filter bowls.

Take fluid samples in accordance with the instructions contained in the applicable technical publication for the particular hydraulic system, and in accordance with chapter 7 of the *Aviation Hydraulics Manual*. Some hydraulic systems are provided with permanently installed bleed valves for sampling ports; on other systems, lines must be disconnected to provide a place to collect a sample. In either case, while the sample is being collected, apply a small amount of pressure to the system. This ensures that the fluid flows out of the sampling point, preventing dirt from entering the system.

Contamination Analysis

Various test procedures are recommended to determine the contamination level in hydraulic fluids. The filter patch test performed with the Contamination Analysis Kit 57L414 (fig. 8-48) provides a reasonable idea of the condition of the fluid. This test consists basically of filtration of a sample of hydraulic system fluid through a special filter paper. The darker the filter paper becomes, the greater the contamination in the sample tested. It is compared to a series of standardized filter discs that, by degrees of darkening, indicate the various contamination levels.

Fluid sampling points and procedures will vary with the support equipment type and model. Employ specific procedures applicable to the particular equipments and consistent with the general requirements as listed in the *Aviation Hydraulics Manual*.

NOTE: Ensure waste oils and fluids are properly disposed of in accordance with applicable environmental instructions and Navy pollution control instructions.

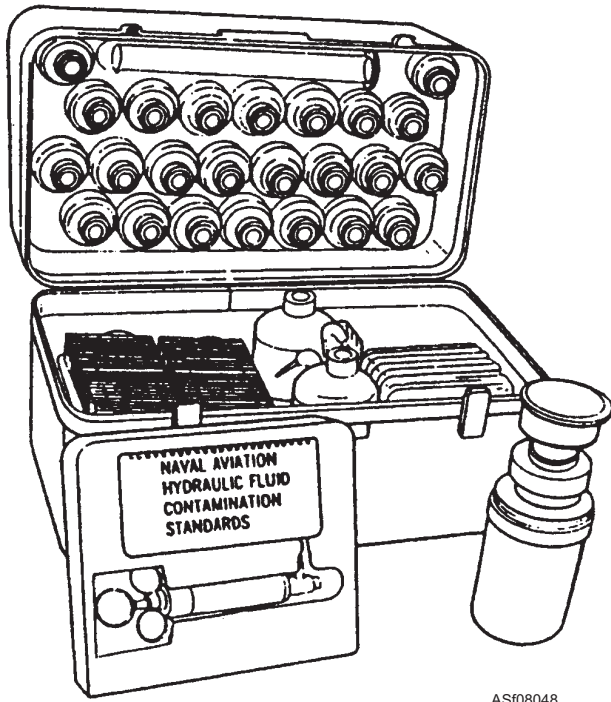

AS108048

Figure 8-48.—Contamination analysis kit.

SYSTEM DECONTAMINATION

When a test with the contamination analysis kit determines that the contamination level in a piece of support equipment exceeds the authorized limits, you can decontaminate the unacceptable equipment by recirculation cleaning, flushing, or purging.

Recirculation Cleaning

Recirculation cleaning is used when equipment is found to be unacceptably contaminated with particulate matter (in excess of Navy standard class 5) but the fluid is otherwise satisfactory. Recirculation cleaning is a decontamination process in which the system to be cleaned is powered from a clean external power source and cycled so as to produce a maximum interchange of fluid between the powered system and the support equipment used to power it. Decontamination is accomplished by circulating the contaminated fluid through the hydraulic filters in the aircraft system and in portable hydraulic power supplies. With this method, the equipment is self-cleaned by using its internal filters—the 3-micron elements in particular.

Flushing

The flushing method of decontamination is used when the support equipment is heavily contaminated

with particulate matter or the fluid contains a substance not readily removed by the internal filters. Flushing is a decontamination method in which contaminated system fluid is removed to the maximum extent practicable and then discarded. It is a draining process that is generally accomplished by powering the aircraft system with a portable hydraulic power supply and allowing the contaminated return line fluid from the aircraft to flow overboard into a suitable receptacle for disposal. In effect, filtered fluid from the portable hydraulic power supply is used to displace contaminated fluid in the system and to replenish it with clean serviceable fluid.

Purging

Purging is a decontamination process in which the aircraft hydraulic system is drained to the maximum extent practicable and the removed fluid discarded. A suitable cleaning agent is then introduced into the hydraulic system and circulated as effectively as possible to dislodge or dissolve the contaminating substances. The cleaning operation is followed by complete removal of the cleaning agent and its replacement with new hydraulic fluid. Upon completion of purging, the affected system is subjected to a period of flushing and recirculation cleaning to ensure adequate decontamination.

Purging of the support equipment hydraulic system is performed only upon recommendation from, and under the direct supervision of, the cognizant engineering activity. It is the responsibility of the cognizant engineering activity to select the required cleaning agents, provide detailed cleaning procedures, and perform tests upon completion of purging to ensure satisfactory removal of all cleaning agents. When possible, a purging operation is done at a Naval Air Rework Facility. Intermediate maintenance activities are not authorized to perform system purging without direct depot supervision.

As with the hydraulic fluid sampling procedures, the procedures for recirculation cleaning, flushing, and purging are contained in chapter 7 of the *Aviation Hydraulics Manual*.

Q8-20. Nonabrasive contamination includes which of the following particles?

1. *Dirt*
2. *Worn seal*
3. *Core sand*
4. *Rust*

Q8-21. *What is the main source of chemical contaminants in hydraulic fluid?*

1. *Fuel*
2. *Oxidation*
3. *Water*
4. *Solvent*

Q8-22. *What type of cloth should you use when cleaning or wiping hydraulic system components?*

1. *Cotton*
2. *Polyester*
3. *Lintfree*
4. *Dirtfree*

Q8-23. *At what time can a hydraulic system be purged to remove contaminants?*

1. *Only under direct supervision of the cognizant engineering activity*
2. *When the AIMD hydraulics shop accomplishes the maintenance*
3. *Only when the contamination level is above a class 5*
4. *Prior to the rework of the pump*

TROUBLESHOOTING AND MAINTENANCE

LEARNING OBJECTIVES: Identify procedures for inspecting, checking, cleaning, testing, and adjusting hydraulic system components. Identify procedures for troubleshooting and repairing hydraulic systems.

Every hydraulic system has two major parts or sections—the power section and the actuating section. A power section develops, limits, and directs the fluid pressures that actuate various mechanisms on the equipment. The actuating section is the section containing the various operating mechanisms and their units, such as brakes, steering, lift cylinders, extend cylinders, and hydraulic motors.

Since an actuating mechanism is dependent on the power system, some of the troubles exhibited by the actuating system may be caused by difficulties in the power system. By the same token, a trouble symptom indicated by a unit of the power system may be caused by leakage from one of the units of an actuating system. When any part of a hydraulic system becomes inoperative, refer to the schematic diagrams located in the applicable technical manual (in conjunction with

tests performed on the equipment) to assist in tracing the malfunction to its source. As previously stressed, no unit should be removed and replaced (or adjusted) unless there is sound reason to believe it is faulty.

TROUBLESHOOTING

Most hydraulic troubles can be included in one or more of the following categories:

- Lack of fluid supply
- External leaks
- Internal leaks
- Physically defective units, or related troubles caused by mechanical control linkages and electrical control circuits

Insufficient fluid in the system results in no pump delivery or, at best, a sluggish or erratic operation. The reservoir must always contain enough fluid to fill the system completely without letting the pump run dry. Always use the proper fluid to replenish a low system. Do not mix hydraulic fluids or reuse old fluid. Ensure all replenishment fluid is properly filtered prior to being dispensed into the reservoir.

Remove and repair or replace defective units when there is an indication of external leakage of the unit.

If foreign particles are found when you remove and disassemble a unit, identify and trace them to the deteriorating source. For example, a common source of foreign particles is found in flexible hose. The cause generally is improper installation or internal deterioration; either can release slivers of the lining into the system, causing units to leak or become inoperative.

To analyze malfunctions in hydraulic systems, like all other systems, you need to have a complete understanding of the system and its operating components. Also, you need to know the interrelationships among the components. For instance, a complete understanding of a pressure regulator lends itself to troubleshooting the entire system, as well as the regulator itself.

Pressure regulators, like all hydraulic components, are normally very reliable pieces of equipment. Nevertheless, they can malfunction. Keep in mind, though, that instead of being a source of trouble, the regulator can be a fairly reliable watchdog on the other units in the system. The particular behavior of the regulator may be the only indication of leakage in places where no other indication is available. It should

be kept in mind that troubleshooting the regulator is done only after the obvious steps have been taken, such as checking the system fluid level to check for external fluid loss and opening shutoff valves.

Troubleshooting the pressure regulator is done by timing the cycle of operation—from the cut-in position to the cutout and back to the cut-in position. A standard regulator operating in a normal system completes this cycle in a certain period of time. This time can be obtained from the equipment manual or closely estimated by maintenance personnel.

Since you normally use the pressure regulator only with a fixed displacement pump, it should take a certain definite time to build up system pressure. For example, suppose a pump has a volume output of 6 gallons per minute, and the system requires 1 gallon of fluid to become completely filled (pressurized). As the system takes only one-sixth of the pump output to build up pressure, it should require only one-sixth of a minute (10 seconds) to pressurize the system. This is true if the system is in good operating condition. But what if the system contains an internal leak? In the 10 seconds usually required to build up pressure, the pump is still delivering 1 gallon, but some of the fluid is being lost. Thus, at the end of 10 seconds, the system cannot be pressurized; therefore, the regulator cannot be cut out. The cut-in and cutout pressure of the regulator can be seen on the system pressure gauge. Once the regulator is cut out, the system should hold fluid under pressure for a reasonable length of time. However, if the system leaks, pressure drops fast and the regulator cuts in faster than normal. These indications may mean that the regulator is faulty or the other components in the system are faulty. However, by isolation techniques, such as subsystem operation and checking shutoff valves, the problem can be located.

If the fault is the regulator, it is probably leaking at the regulator check valve or at the regulator bypass valve. A leaking regulator check valve is one of the most common and easily recognized troubles. Again, the regulator cycle is affected. With the regulator cut-in, the check valve is open, and fluid is flowing into the system. When the system pressurizes, the check valve closes, and the regulator is cut out. Therefore, a leaking check valve does not affect the cutout time of the regulator, but it does affect the cut-in time.

The purpose of the check valve is to trap fluid under pressure in the system during the regulator cutout operation. However, it cannot do this if there is leakage around the seat. Even a slight leak around the valve seat causes the regulator to cut in faster than it

should, but a bad leak causes the regulator to cycle rapidly (chatter). This rapid cycling, as indicated on the system pressure gauge, is usually caused by a leaking valve. Thus, a leaking check valve gives normal regulator cutout and faster than normal cut-in operation.

The regulator bypass valve may also leak, causing an indication that affects the cycle of the regulator. If the bypass leaks, part of the fluid from the pump, which should be going into the system, bypasses and returns to the reservoir. This bypass causes the regulator to take longer than usual to cut out. Once the regulator has cut out, the bypass opens. Therefore, it does not affect the regulator cut-in cycle.

You can see that isolation of different subsystems, sections, and components is a vital part of troubleshooting the hydraulic system or any one of its components.

MAINTENANCE

Hydraulic systems maintenance includes servicing, preoperational inspections, periodic (scheduled) inspections, repair, and testing following repair. The key to hydraulic system dependability is the attention given to the cleanliness of the repair facilities. Externally introduced contaminants are credited for more component failure than any of the self-induced contaminations during normal operating conditions.

The various repair procedures for the more common hydraulic system components are discussed in the following text.

Hydraulic Pumps

All hydraulic pumps have one thing in common—precision construction. In general, damaged or worn pump parts should be replaced, as they do not lend themselves readily to repair. However, some manufacturers do allow restoration of sealing surfaces to their original flat plane if it can be done by lapping (polishing). Also, very minor scratches, scoring, and corrosion can be removed with crocus cloth.

Generally, the maintenance of hydraulic pumps consists of disassembly, inspection, repair, and testing. After disassembly, thoroughly clean and critically inspect all parts for nicks, cracks, scratches, corrosion, or other damage that might cause pump malfunction. Inspect all threaded parts and surfaces for damage. Inspect pistons, piston

shafts, and springs for distortion, and all check valves for proper seating.

Replace all defective parts that are not repairable, and replace all kit parts and cure-dated parts at each disassembly. Before reassembly, lubricate all internal parts with the specified type of clean hydraulic fluid.

Because of the many different versions of pumps and the complexity of most piston pumps, refer to the applicable technical manual for repair limits, procedures, and testing information. Pay particular attention to the Source, Maintenance and Recoverability code (SM&R code) to determine the lowest level of repair that is authorized on these components.

Testing hydraulic pumps after repairs is a must. This should be done by activities that have proper test machines. AIMD airframe hydraulic shops usually have the correct testing machines and trained personnel to test these pumps, along with other accessories, such as relief valves, directional valves, and actuating cylinders.

Actuators

Maintenance of cylinders in general is relatively simple; the most common trouble is leakage. As with all other hydraulic units discussed in this chapter, consult the technical manual for the specific cylinder for all maintenance information.

Maintenance of hydraulic motors is generally the same as that discussed earlier for hydraulic pumps.

Hydraulic Valves

Hydraulic valves, like most other hydraulic units, normally require little maintenance if the fluid is kept clean. However, they do occasionally fail. Internal leakage and control adjustments are the most common valve problems.

Generally, the maintenance of hydraulic valves consists of disassembly, inspection, repair, and testing. The amount of maintenance that can be performed is

primarily determined by the type of valve and the available facilities. Some valves are not repairable.

Replace all defective parts that are not repairable, including all kit parts and cure-dated parts at each disassembly. Before reassembly, lubricate all internal parts with the specified type of clean hydraulic fluid. After you reassemble a valve, test it on a test machine. The tests normally include flow control, pressure settings (for relief valves and regulators), and internal leakage. Consult the applicable technical manual for maintenance, testing, and repair information.

Reservoirs

Reservoirs are fairly simple tanks that require periodic flushing and cleaning. Since the reservoir collects foreign material contaminants in the bottom, the drain valve in the bottom of the tank should be opened to allow any sediment to be purged. Additionally, most reservoirs are designed with clean-out covers, illustrated earlier in figures 8-5 and 8-6, to assist in inspection and maintenance.

Accumulators

Accumulators, designed like cylinder actuators, are similarly repaired by using the same techniques. Caution must be exercised to ensure that the pneumatic pressure has been relieved prior to disassembly of an air-operated accumulator.

Filters

Maintenance of filters is relatively simple since it mainly involves cleaning the filter housing and replacing or cleaning the filter elements. Replace the element on filters with micronic (paper) elements, and clean the elements on filters using porous metal elements. Clean the porous metal elements with ultrasonic cleaning equipment. Completely test the filters that have been cleaned and repaired before reinstalling in the system. This includes pressure setting of the bypass valve, operation of the contamination indicators, leakage tests, and proof pressure tests. Consult the technical manuals for the equipment or the filter design for test information.

Q8-24. What are the two major sections of a hydraulic system?

- 1. The power section and the actuating section*
- 2. The power section and the pump section*
- 3. The cylinder section and the pump section*
- 4. The valve section and the actuating section*

Q8-25. A pressure regulator is used with which of the following pumps?

- 1. A variable speed pump*
- 2. A rotary pump*
- 3. A fixed displacement pump*
- 4. A high-pressure pump*

Q8-26. What is the key to hydraulic system dependability?

- 1. The age of the system*
- 2. The usage the system receives*
- 3. The design of the system*
- 4. The cleanliness of the system and repair facility*

Q8-27. Which of the following problems is one of the most common valve problems?

- 1. Normal wear*
- 2. Internal leakage*
- 3. Freezing up*
- 4. Worn O-rings*

CHAPTER 9

PNEUMATICS

INTRODUCTION

As an Aviation Support Equipment Technician, you will be responsible for maintaining compressed nitrogen and air handling equipment. To do so, you must be able to operate the equipment as well as perform preventive and corrective maintenance on it. You will need to have knowledge of the properties of compressed nitrogen and air, storage devices, and equipment for delivering the gases to users, as well as safety procedures for protecting you and the equipment.

PNEUMATIC SYSTEMS

LEARNING OBJECTIVE: Identify the principles of pneumatic systems.

Pneumatics is the branch of fluid power that pertains to gaseous pressure and flow. Pneumatics differs from hydraulics in that gases (usually compressed air or nitrogen) rather than liquids are used to transmit forces.

The characteristics of a confined gas are very similar to those of a confined liquid. Like liquid, a gas has no definite shape, but conforms to the shape of its container. Pascal's law applies to gases because gases transmit force in much the same way that liquids do.

Unlike liquids, however, gases are highly compressible. This characteristic is the major difference between the two, and is the reason that gases provide a much less rigid force than liquids. For example, compare the hydraulic system shown in figure 9-1, view A, to an almost identical pneumatic system shown in view B. It would require the same amount of force on piston (1) of either system to overcome equal resistant forces acting against piston (2). However, because of its compressibility, a gas decreases in volume as it increases in pressure. Therefore, in the gaseous system, a large portion of the travel of piston (1) is used to compress the gas. For this reason, gases for pneumatic systems, such as shown in figure 9-1, view B, are compressed in advance and stored in attached containers. Gas is then released from the container in sufficient volume and at the correct pressure to accomplish the required work.

NOTE: *Fluid Power*, NAVEDTRA 14105, contains a detailed discussion of the fundamentals of hydraulics and pneumatics and the operation of the various types of components found in fluid power systems. You should supplement this text by reading pertinent sections of *Fluid Power*.

Q9-1. What is the major difference between gases and liquids?

1. *Liquids have no definite shape*
2. *Liquids conform to the shape of their container*
3. *Gases are highly compressible*
4. *Gases transmit force in a completely different manner*

NITROGEN

LEARNING OBJECTIVE: Identify the types and characteristics of gaseous nitrogen.

To effectively service and maintain nitrogen and other compressed gaseous servicing equipment, you must be familiar with the components and operating procedures of the equipment. This text covers some of

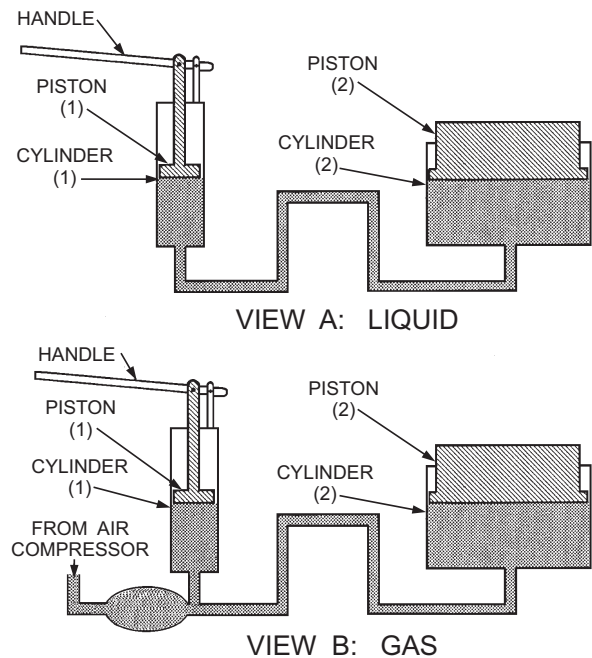

ASF09001

Figure 9-1.—Transmission of force by liquids and gases.

the equipment used to service aircraft pneumatic and life support systems. There are many similarities between hydraulic and pneumatic systems.

For all practical purposes, nitrogen is considered to be an inert gas. (Inert is defined as chemically inactive, not combining with other chemicals.) However, nitrogen is not totally inert, like helium or argon, for there are many nitrogen derivative compounds. One such compound is nitrate, which is used in fertilizers and explosives. Under natural conditions, nitrogen is very slow to combine chemically with other elements. There are, however, chemical and electrical processes by which nitrogen can be combined with other substances. Such processes are called *nitrogen fixation*.

Although 80 percent of our atmosphere is pure nitrogen, as a gas it does not support life. When released in a confined space, nitrogen causes asphyxia (the loss of consciousness as a result of too little oxygen and too much carbon dioxide in the blood). Nitrogen is not poisonous, but unless oxygen is mixed with it, it cannot support life. Also, nitrogen gas does not support fires, cause rust, or decay most of the materials with which it comes in contact. Because of these properties, nitrogen is preferred over compressed air in pneumatic systems, especially aircraft and missile servicing systems.

Nitrogen is obtained by fractional distillation of air. On some ships, particularly aircraft carriers, nitrogen is obtained as a by-product of oxygen production. In addition to being used in pneumatic systems, nitrogen is used extensively in ships as an inert blanket over aviation fuel and other special fuels in their storage tanks.

There are two classes of gaseous nitrogen, and both are available in military supply.

- **Class 1**, oil-free (O.F.) (formerly water-pumped). Most nitrogen gases are manufactured from liquid nitrogen as a dry, oil-free gas. The term *dry*, when applied to a gas, means that the gas has a moisture content of less than 0.02 milligrams per liter. Oil-free means that the gas has not been in contact with oil during processing, and that it was either compressed by a water-lubricated compressor or is produced from a liquid that is oil-free. Most oil-free gases are also dry. Class 1 gaseous nitrogen is stored in cylinders that are gray with two black bands near the top.

- **Class 2**, oil-tolerant (O.T.) (formerly oil-pumped). The term *oil-tolerant* means that traces of oil may be carried in the gas because an oil-lubricated

compressor was used in the processing. This term is used only when the gas is normally supplied in both O.F. and O.T. grades. A gas cylinder that is not labeled with O.F. or O.T. is presumed to be O.T. Oil-tolerant nitrogen may be used when there is no potential danger of contaminating systems with oil. Class 2 gaseous nitrogen is stored in cylinders that are gray with one black band near the top.

Class 2 (oil-pumped) nitrogen can be dangerous in certain situations. For example, if oil-pumped nitrogen were used to inflate a tire, an oil film (hydrocarbon) may build up on the inside walls of the tire, soaking into the pores of the rubber. This should not hurt the tire, and by itself does not present a combustion hazard. However, if at a later time, nitrogen is not available and compressed air (the approved alternative) is used to inflate the tire, the hydrocarbon film will come in contact with compressed air. A mixture of hydrocarbons and compressed air is definitely combustible.

WARNING

Oil-pumped nitrogen must NEVER be used to purge oxygen systems. An explosion could result.

When oil-pumped nitrogen is available, there is always the chance that someone will unwittingly use it to purge an oxygen system. And although oxygen does not burn, it does support and accelerate combustion and causes oil to burn more easily and with greater intensity. For this reason, **oil-pumped nitrogen is never used to purge oxygen systems**. If the small amount of oil remaining in the nitrogen were to come in contact with the oxygen, an explosion could result.

Safety rules concerning the use of gaseous nitrogen are similar to those cited for other nonflammable, nonoxidizing, and nontoxic compressed gases.

Q9-2. Which of the following qualities of nitrogen makes it desirable to be used for servicing aircraft systems?

1. *It contains oil for proper lubrication of aircraft pneumatic systems*
2. *It is considered an inert gas and is chemically inactive*
3. *It does not contain corrosion by-products*
4. *It is less compressible than atmospheric air and is moisture free*

Q9-3. How is nitrogen obtained on an aircraft carrier?

1. It is manufactured by using a nitrogen-condensing pump
2. It is purchased and stored by the supply department
3. It is a by-product of oxygen production
4. It is manufactured by using a nitrogen generator

Q9-4. A nitrogen bottle containing oil-tolerant nitrogen has which of the following paint schemes?

1. A gray bottle with one black band
2. A gray bottle with two black bands
3. A gray bottle with three black bands
4. A gray bottle with no bands

Q9-5. Which type of nitrogen should NEVER be used to purge an oxygen system?

1. Class 1
2. Class 2
3. Class 3
4. Class 4

PNEUMATIC-TYPE SUPPORT EQUIPMENT

LEARNING OBJECTIVES: Identify the components of pneumatic systems. Identify procedures for inspecting, troubleshooting, and repairing pneumatic systems and related components.

The portable high-pressure nitrogen cylinder (commonly called a *walk-around bottle*) and the A/M26U-4 nitrogen servicing unit are typical of nitrogen servicing equipment currently in use by the Navy. We will also briefly cover low-pressure air compressors.

PORTABLE NITROGEN CYLINDERS

The walk-around bottle, shown in figure 9-2, is designed for hand carrying to remote locations for charging such components as accumulators, aircraft struts, and high-pressure tires. The user can control delivery pressure up to a maximum of 3,000 psi.

Nitrogen cylinders are painted gray with black stripes. One black stripe identifies oil-pumped nitrogen, and two black stripes identify water-pumped nitrogen. In addition to the color codes, the exact

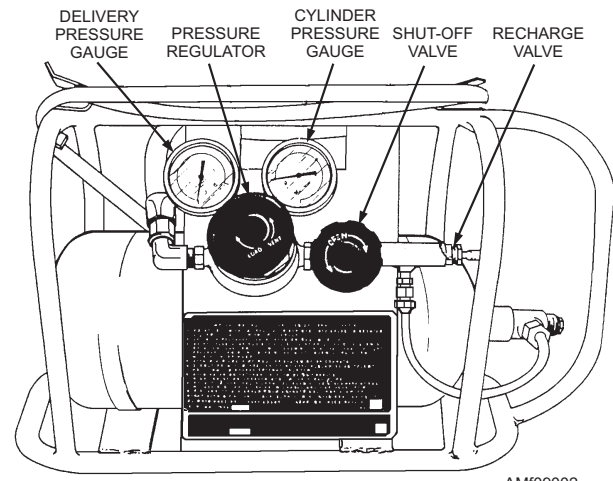

Figure 9-2.—Portable high-pressure nitrogen cylinder.

identification of the contents is printed in white on the cylinder. The cylinder's last hydrostatic test date is also stenciled across the bottom of the cylinder.

Components

The components of the walk-around bottle are mounted on a one-piece welded frame designed to be hand-carried. The cylinder assembly is fastened to the bed of the frame by means of two quick-coupling clamps, which provide fast removal and installation of the cylinder. The pressure regulator is bolted to the front of the frame, and all other servicing parts are attached to the regulator.

The top of the frame has four brackets for coiling the servicing hose when it is not in use. The major components are the cylinder, the shutoff valve, the pressure regulator, the cylinder pressure gauge, the delivery pressure gauge, the bleed valve, the servicing hose, and the recharge valve.

CYLINDER.—The nitrogen cylinder is a 500-cubic-inch capacity reservoir designed for a working pressure of 3,000 psi. It is shatterproof and contains a safety disc that is designed to burst between 4,000 to 4,500 psi to prevent over pressurizing the cylinder during recharge.

SHUTOFF VALVE.—The shutoff valve controls the flow of nitrogen from the cylinder to the inlet of the regulator. It is a needle valve that is open only during servicing operations. The valve is closed when the unit is stored or the cylinder is being recharged.

PRESSURE REGULATOR.—The pressure regulator is a single-stage assembly that allows the operator to set the delivery pressure. Once the delivery pressure is set, the regulator maintains this pressure as

the cylinder pressure decreases. The regulator also contains an adjustable relief-venting valve to prevent over pressurizing the system being charged.

CYLINDER PRESSURE GAUGE.—The cylinder pressure gauge indicates the pressure remaining in the cylinder.

DELIVERY PRESSURE GAUGE.—The delivery pressure gauge indicates the regulated delivery pressure to which the regulator is set during a charging operation.

BLEED VALVE.—The bleed valve controls the flow of nitrogen from the regulator to the servicing hose, and it allows the user to bleed the servicing hose before removing it from the system being charged. It is spring-loaded and is designed to automatically shut off the nitrogen flow before it vents the servicing hose.

NITROGEN HOSE.—The 96-inch, high-pressure, nitrogen hose provides a connection between the unit and the item to be charged.

RECHARGE VALVE.—The recharge valve is open only during recharging to allow nitrogen to flow into the cylinder. The valve is closed during all other operations to prevent nitrogen from the cylinder escaping to the atmosphere.

Operation

Figure 9-3 is a schematic flow diagram of the portable high-pressure cylinder. The high-pressure nitrogen in the cylinder is fed through the shutoff valve and entrapped at the inlet of the pressure regulator.

The cylinder pressure gauge indicates the amount of pressure at the pressure regulator inlet. Once the

operator adjusts the pressure regulator to the desired pressure, the pressure registers on the delivery pressure gauge. The regulated nitrogen pressure is then fed through the bleed valve, which is kept in the FLOW position during charging, to the servicing hose.

CHARGING AN EXTERNAL SYSTEM.— Follow these steps to charge an external system from a walk-around bottle. (Refer to figures 9-2 and 9-3 for controls and indicators.)

WARNING

Always open valves slowly. Servicing hose should be slack when under pressure and should not be stretched to make a connection.

1. Ensure the bleed valve, the pressure regulator, and the shutoff valves are closed.

NOTE: Remember that pressure regulators turn opposite to other valves. That is, pressure regulators open with a clockwise rotation and close with a counterclockwise rotation. Take care with the regulator because the threads inside are brass and will strip very easily.

2. Open the shutoff valve and read the cylinder pressure on the cylinder pressure gauge. It should be higher than the system to be charged. (Maximum pressure is 3,000 psi.)
3. Adjust the pressure regulator to the desired delivery pressure. Read the pressure on the delivery pressure gauge.
4. Open and close the bleed valve quickly to allow a short burst of nitrogen to clean and purge the hose. Then, attach the hose to the system to be charged.

WARNING

When using the walk-around bottle to inflate tires, always use an approved remote inflator assembly to prevent possible personal injury. NAVAIR 17-1-123 covers the requirements for the remote inflator assembly.

5. Slowly rotate the bleed valve to the FLOW position, allowing nitrogen to flow into the servicing hose.

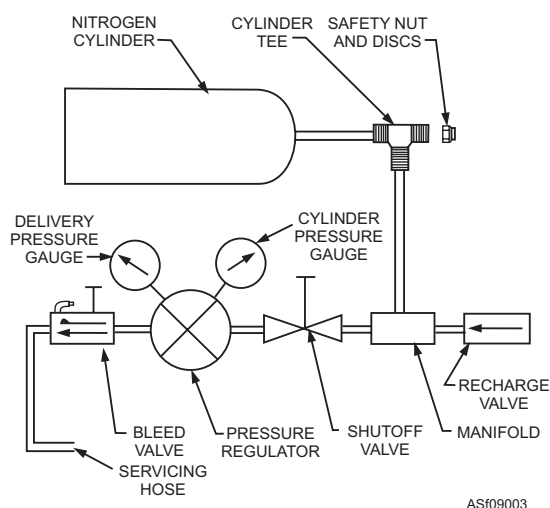

Figure 9-3.—Portable high-pressure nitrogen cylinder schematic.

6. Open the servicing valve of the system being charged.
7. When charging is completed, close the servicing valve on the system being charged.
8. Rotate the bleed valve to the BLEED position to expel nitrogen from the servicing hose.
9. Disconnect the servicing hose.
10. Close the shutoff valve, and open the bleed valve. The cylinder pressure gauge and the delivery pressure gauge should drop to about zero.
11. Close the pressure regulator and bleed valve.
12. Cap and stow the servicing hose.

RECHARGING THE NITROGEN CYLINDER.—If cylinder pressure falls below what is required for the next charging job, the cylinder must be recharged. If recharging is required, follow the procedures outlined below.

CAUTION

Do not over pressurize the cylinder. It has a working pressure of 3,000 psi and should only be recharged to this pressure.

1. Ensure the pressure regulator and bleed valve are closed. Open the shutoff valve to determine the amount of pressure in the cylinder, and then close it to isolate the regulator.
2. Remove the dust cover from the recharge valve, and connect a nitrogen charging station hose to the recharge valve.
3. Open the recharge valve. This permits nitrogen to flow into the cylinder.

NOTE: The pressure regulator on the charging station should be adjusted to 3,000 psi.

4. Open the servicing valve on the charging station until you sense that the flow of nitrogen into the cylinder has stopped, and then close the charging station servicing valve.
5. Open the cylinder shutoff valve and check the pressure indicated on the cylinder pressure gauge. When the cylinder pressure gauge reads 3,000 psi, close the recharge valve to stop the flow of nitrogen to the cylinder.

6. Relieve pressure in the charging station hose, and slowly disconnect it from the recharge valve. (The hose is disconnected slowly to allow any trapped gas to vent.) Replace the dust cover on the recharge valve.

Maintenance

The portable high-pressure nitrogen cylinder, if handled properly, requires very little attention other than scheduled maintenance. If the unit shows signs of malfunctioning, however, the trouble must be located and remedied. Table 9-1 lists some of the possible troubles, their causes, and remedies.

NOTE: The troubleshooting charts presented in this training manual are only examples and are not necessarily complete. Before attempting repairs on any item of equipment, consult the applicable maintenance instruction manual. There you will find complete, up-to-date instructions for maintaining the equipment.

Safety

For safe operation of the portable, high-pressure, walk-around bottle, strictly observe the following safety precautions:

- Open all valves slowly.
- Position the bottle so that the servicing hose is not under tension while charging. Never stretch the servicing hose to reach a connection.
- Never drag the servicing hose or pull the bottle by the servicing hose. Always coil the hose neatly around the four frame hose brackets when not in use, and secure the chuck with the strap assembly.
- Never permit oil, grease or readily combustible material to come into contact with the system components or fittings.
- Always keep the recharge valve capped to prevent entry of foreign matter into the system.
- After a charging operation, always bleed the servicing hose before securing the regulator. This prevents system pressure and contaminants from backing up into the regulator chambers.
- Always keep the nitrogen recharging valve safety-wired to the manifold.
- Abide by the color code of the cylinder. That is, NEVER recharge a cylinder coded for

Table 9-1.—Portable High-Pressure Nitrogen Cylinder Troubleshooting Chart

Trouble	Probable Cause	Remedy
With shutoff valve open, cylinder pressure gauge reads zero	Cylinder completely discharged Cylinder safety disc blown Shutoff valve defective	Recharge cylinder Replace safety disc Replace shutoff valve
With shutoff valve open and pressure regulator set to zero, cylinder loses pressure	Gas leaking	Locate and repair leak
Regulator control has no effect on delivery pressure gauge reading	Delivery pressure gauge defective Regulator defective	Replace delivery pressure gauge Replace regulator
Unit does not charge an external system during charging operation	Hose valve in BLEED position Hose valve defective Servicing hose defective	Rotate hose valve to FLOW position Replace hose valve Replace servicing hose
Cylinder does not pressurize during recharging operation	Recharge valve defective Safety disc blown Shutoff valve regulator and hose valve are open	Replace recharge valve Replace safety disc Close shutoff valve, regulator, and hose valve
Cylinder is loose in its mounting	Cylinder clamp loose	Tighten cylinder clamp

water-pumped nitrogen with compressed air or oil-pumped nitrogen.

- Do not charge this system with oxygen or interchange components with oxygen components. To do so may cause an explosion.
- Never charge systems at higher than prescribed pressures.
- Always close the regulator after use to prevent accidental over-pressurization during subsequent charging operations.
- Because of the high pressure used in this system, do not, under any circumstances, interchange components of this system with parts from other systems.
- Release all pressure from the nitrogen cylinder before disconnecting any tubing.

NITROGEN SERVICING TRAILERS

Nitrogen servicing trailers provide a mobile source of high- and low-pressure nitrogen for servicing aircraft high-pressure systems and for inflating tires. The nitrogen servicing trailer most widely used in the fleet is the A/M26U-4 nitrogen servicing unit. It is

discussed in detail in the following paragraphs. The A/M26U-4, shown in figure 9-4, is typical of other nitrogen servicing trailers you might encounter, and most of what you will learn about it applies to the other trailers.

The A/M26U-4 has a welded frame assembly mounted on a two-wheel axle and a retractable swivel caster front wheel. The compressed gas cylinders are mounted to the frame in two groups of three.

A drawbar coupler ring on the front of the frame assembly allows the equipment to be towed by a vehicle that is equipped with a pintle assembly.

A hand-operated, mechanical brake is used to secure the cart while it is stationary. The brake system uses a cable linkage connected to a cam, which is located on the wheel backplate.

Components

Figure 9-5 is a view of the control panel of the trailer, and figure 9-6 is a system nitrogen flow diagram. The numbers inserted in parentheses in the text are to help you locate the various components in the figures.

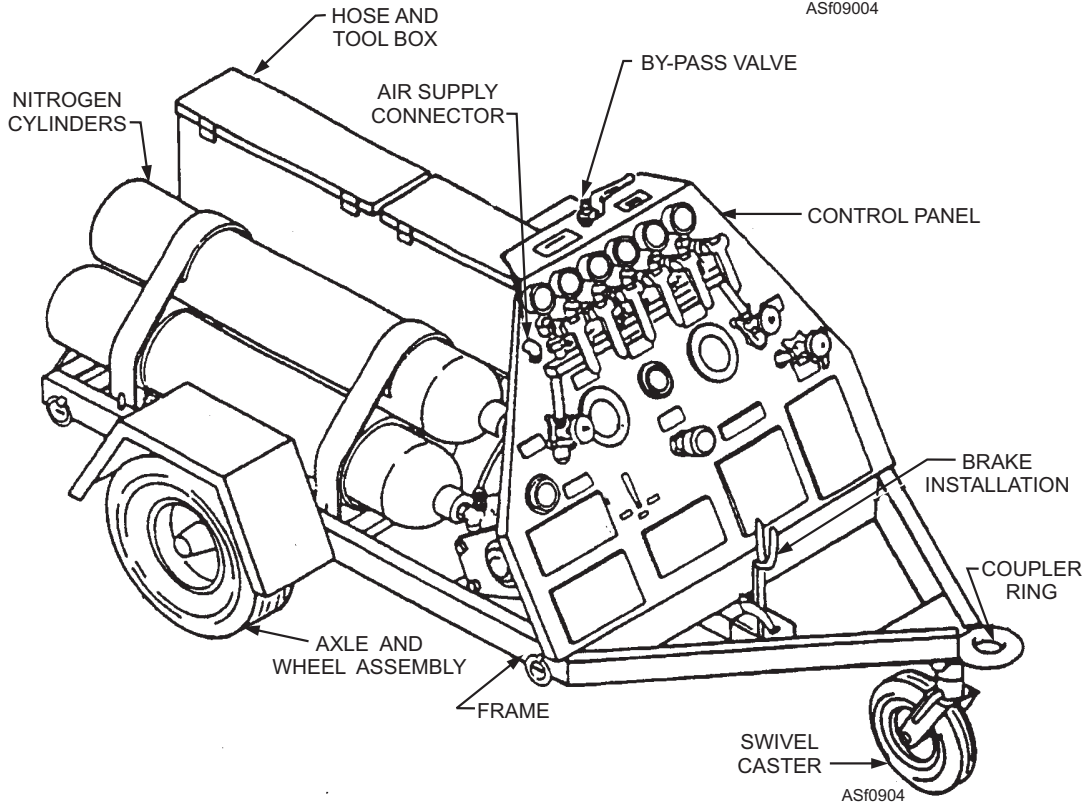
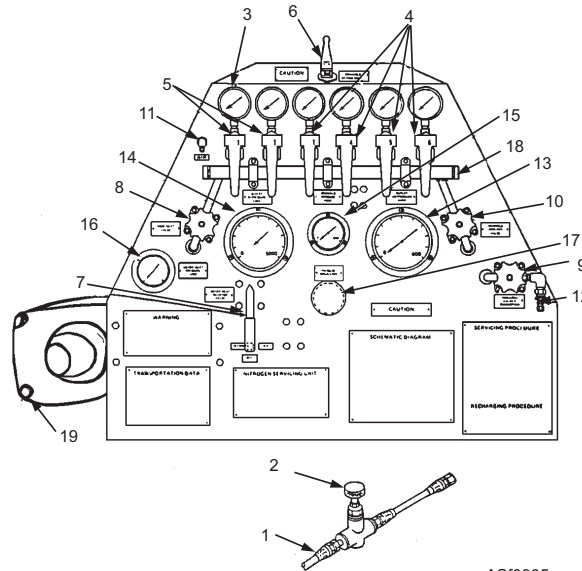
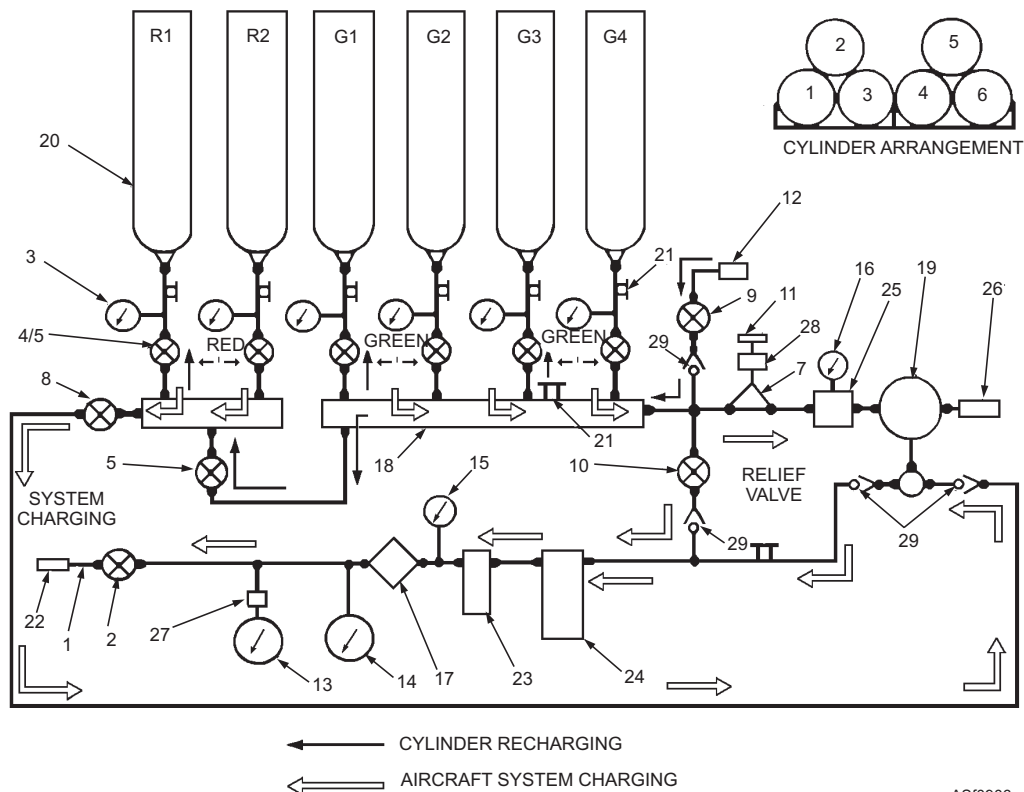

Figure 9-4.—A/M26U-4 (NAN-4) nitrogen servicing unit.



- | | |
|---|--|
| <ol style="list-style-type: none"> 1. Servicing line 2. Servicing line valve 3. Cylinder pressure gauges (6 each) 4. Lever control valves (green) (4 each) 5. Lever control valves (red) (2 each) 6. Manifold bypass valve 7. Motor inlet selector valve 8. Pump inlet valve 9. Recharge valve 10. Manifold shutoff valve | <ol style="list-style-type: none"> 11. External air connection 12. Recharge connection 13. Pressure gauge, 0-600 psi (low pressure) 14. Pressure gauge, 0-5,000 psi (high pressure) 15. Pressure gauge, 0-5,000 psi (manifold pressure) 16. Pressure gauge, 0-200 psi (motor inlet) 17. Pressure regulator 18. Manifold assembly 19. Motor and pump |
|---|--|

Figure 9-5.—A/M26U-4 nitrogen servicing unit controls and indicators.



- | | |
|---|---|
| 1. Servicing line | 16. Pressure gauge, 0-200 psi (motor inlet) |
| 2. Servicing line valve | 17. Pressure regulator |
| 3. Cylinder pressure gauges (6 each) | 18. Manifold assembly |
| 4. Lever control valves (green) (4 each) | 19. Motor and pump |
| 5. Lever control valves (red) (2 each) | 20. Nitrogen storage cylinders (6 each) |
| 6. Manifold bypass valve | 21. Frangible safety discs (7 each) |
| 7. Motor inlet select valve | 22. Servicing line connection |
| 8. Pump inlet valve | 23. Filter |
| 9. Recharge valve | 24. Purifier |
| 10. Manifold shutoff valve | 25. Motor regulator |
| 11. External air connection | 26. Exhaust muffler |
| 12. Recharge connection | 27. Low-pressure gauge cutout |
| 13. Pressure gauge, 0-600 psi (low pressure) | 28. Filter (inlet-air) |
| 14. Pressure gauge, 0-5,000 psi (high pressure) | 29. Check valve |
| 15. Pressure gauge, 0-5,000 psi (manifold pressure) | |

Figure 9-6.—A/M26U-4 system nitrogen flow diagram.

CONTROL PANEL.—The control panel, figure 9-5, mounts the necessary valves, gauges, and plumbing components to operate the nitrogen servicing unit. The valves (4 through 10 and 17), gauges (3 and 13 through 16), and plumbing components direct the flow and control the pressure of nitrogen throughout the servicing system. A motor and pump assembly (commonly referred to as a booster pump), a motor regulator, a purifier, and a filter are attached to the back of the control panel. (Only a part of the motor and pump assembly is shown in figure 9-5.)

NOTE: The number in parenthesis following the component name refers to figures 9-5 and/or 9-6.

NITROGEN CYLINDERS.—The nitrogen cylinders (20) store the supply of nitrogen for the unit. They are mounted horizontally and held in place by straps, as shown in figure 9-4. The cylinders are gray with two black bands, indicating that they contain oil-free (formerly water-pumped) nitrogen. Note that the cylinders do not have cutoff valves in the neck, as do most other cylinders. For this reason, you cannot install full cylinders on this unit; the cylinders must be installed empty and charged in place. Nitrogen pressure in all cylinders should be maintained between 200 and 3,500 psi. The gaseous nitrogen used in this system is Federal Specification BB-N-411, Type 1 (gaseous), Class 1 (oil-free), Grade B (99.50 percent pure, low-moisture content).

MANIFOLD.—The manifold (18) provides a common connecting point for all of the cylinders. It is a split type that incorporates a bypass valve (6).

MANIFOLD BY-PASS VALVE.—The manifold bypass (6) valve connects the two sections of the manifold. It is used when recharging the cylinders. It must be closed at all times except when recharging or when using air drive.

LEVER CONTROL VALVES.—The lever control valves (4 and 5), attached to the manifold, control the flow of nitrogen from the cylinders into the manifold. There is a valve for each of the six cylinders. Four of the valves are painted green and two of them are painted red. The green lever control valves (4) control the flow of nitrogen from cylinders G1 through G4 for direct servicing from the cylinders and for motor operation. The red lever control valves (5) control the flow of nitrogen from cylinders R1 and R2 for the pump system.

CYLINDER PRESSURE GAUGES.—The cylinder pressure gauges (3) indicate the nitrogen pressure remaining in the cylinders. The gauges are attached to the lever control valves (4 and 5) in such a manner that they display cylinder pressure continuously, even when the valves are closed.

MANIFOLD SHUTOFF VALVE.—The manifold shutoff valve (10) controls the flow of nitrogen from the manifold to the pressure regulator (17) via the purifier (24) and filter (23). A check valve is installed in line with and on the service side of the manifold shutoff valve to prevent reverse flow.

PURIFIER.—The purifier (24) removes foreign material and moisture from the gas supplied by the nitrogen cylinders. It is a cylinder type with a replaceable cartridge.

FILTER ASSEMBLY.—The filter assembly (23), located downstream from the purifier, traps any particles that pass the purifier. The filter element is a 5-micron microfilm type. A bypass valve with a cracking pressure of 50 psi is installed in the filter. The bypass valve assures continued operation of the system and protection from rupture of the element.

MANIFOLD PRESSURE GAUGE.—The manifold pressure gauge (15) indicates the nitrogen pressure at the manifold side of the pressure regulator (17).

PRESSURE REGULATOR.—The pressure regulator (17) controls the pressure supplied to the servicing hose valve (2) and servicing hose (1). Two

types of regulators are used with the A/M26U-4. They both serve the same purpose, but their operating procedures are slightly different. Always check the appropriate technical documentation for the regulator that you are using.

OUTLET PRESSURE GAUGES.—The outlet pressure gauges (13 and 14, low-pressure and high-pressure, respectively) indicate the pressure in the servicing hose. The low-pressure gauge (13) has a range of 0 to 600 psi for servicing low-pressure (0 to 500 psi) systems. A cutout (27) is incorporated to prevent damage to the low-pressure gauge when the pressure regulator is adjusted to a pressure exceeding the range of the gauge. The high-pressure gauge (14) has a range of 0 to 3,500 psi for servicing high-pressure systems (500 to 3,500 psi).

SERVICING LINE VALVE.—The servicing line valve (2) admits nitrogen into the servicing line (1), and vents pressure from the servicing line after a servicing operation.

PUMP INLET VALVE.—The pump inlet valve (8) controls the flow of nitrogen from the manifold to the suction side of the pump.

MOTOR INLET SELECTOR VALVE.—The motor inlet selector valve (7) controls the flow of nitrogen from the manifold (18) through the motor regulator (25) to the motor, and it controls the flow of low-pressure air from the external air connection (11) through the motor regulator (25) to the motor. The motor inlet selector valve has three operating positions: NITROGEN/OFF/AIR.

MOTOR REGULATOR.—The motor regulator (25) is a preset regulator that controls the amount of nitrogen or air going to the motor. It is located behind and bolted to the control panel.

MOTOR INLET PRESSURE GAUGE.—The motor inlet pressure gauge (16) indicates the amount of pressure at the outlet of the motor regulator.

MOTOR AND PUMP ASSEMBLY.—The motor and pump assembly (19) is used to boost delivery pressure when pressure in the cylinders is not sufficient to satisfy the demand of the system being serviced. Two different assemblies are currently in use. One uses a single-acting pump cylinder. The other uses a double-acting pump cylinder. Both operate essentially the same.

Figure 9-7 shows a single-acting pump cylinder unit and illustrates how the gas-operated motor and pump supply boost pressure to the system servicing

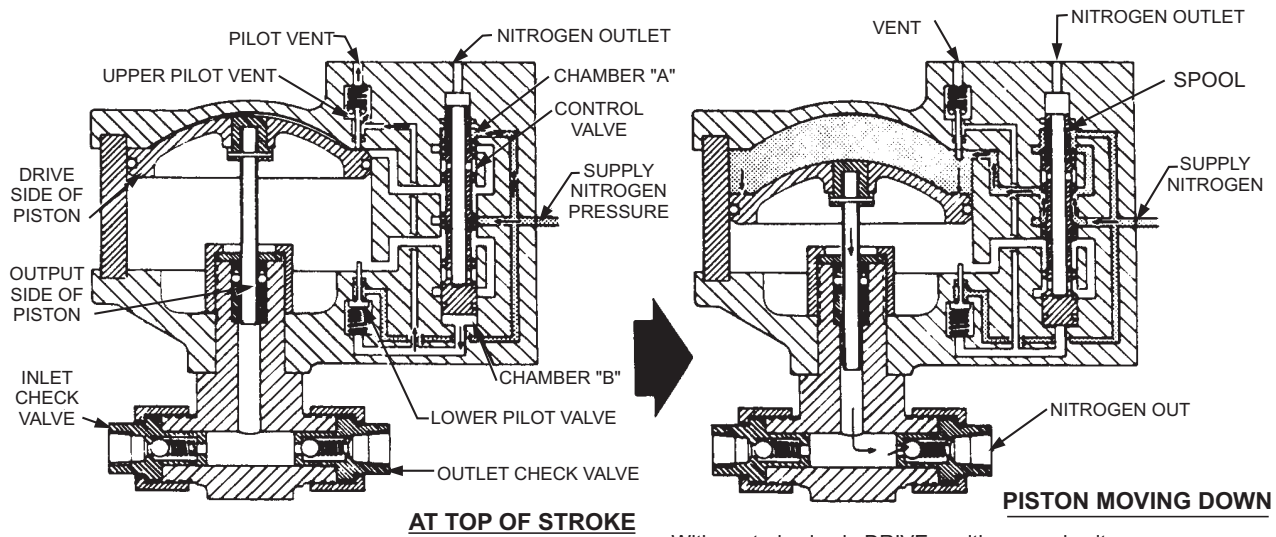

With piston in upper position, upper pilot valve is open. This exhausts chamber B. Supply nitrogen pressure in chamber A then moves control valve to DRIVE position.

With control valve in DRIVE position, supply nitrogen pressure acts on upper side of piston. This forces piston assembly downward and delivers nitrogen under high pressure thru the outlet check valve. Nitrogen from lower side of piston is exhausted thru control valve spool.

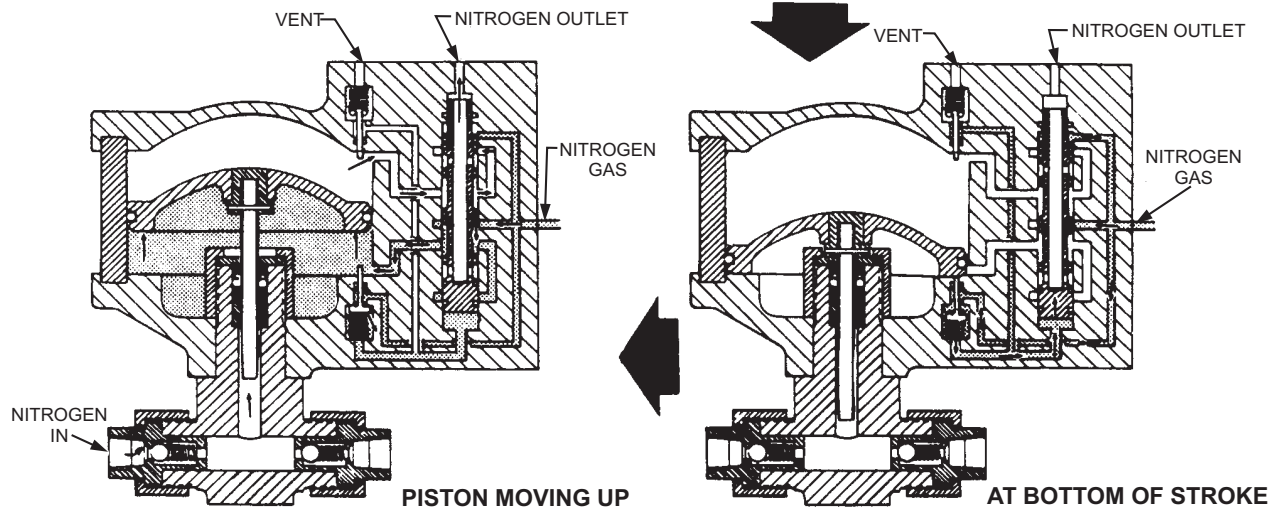

With control valve in RETURN position, supply nitrogen pressure acts on lower side of piston and moves it upward. This pushes the piston assembly up, sucking gas in thru inlet check valve. Nitrogen from upper side of piston is exhausted thru control valve spool.

As piston reaches bottom position it opens lower pilot valve. This delivers pressure to chamber B. Since chamber B has larger area than chamber A, control valve is moved to RETURN position

AS10907

Figure 9-7.—Flow during a motor and pump assembly cycle.

line. The motor and pump assembly has an output pressure 30 times the drive pressure. It is an automatic cycling device, cycled by a nondetented, unbalanced spool that is alternately pressurized and vented by the pilot system. The assembly is designed to operate dry (without lubrication) to supply nitrogen that is free of hydrocarbon contamination.

The pneumatic drive section consists of a drive piston assembly, a cycling control valve, two pilot control valves (mounted in the upper and lower caps), a flow tube to direct flow to the top side of the drive piston, and a pilot tube to connect the upper and lower

pilot control valves. The cycling control valve operates without springs or detents, and is cycled by alternately pressurizing and venting (by action of the pilot valve) chambers of an unbalanced pressure-operated spool. In figure 9-7, the gas flow is illustrated for one cycle of the motor and pump operation. In figure 9-7, notice the drastic difference (30:1) between the drive side and the output side of the piston.

The parts breakdown shown in figure 9-8 also illustrates the relative sizes of the input piston and the output piston.

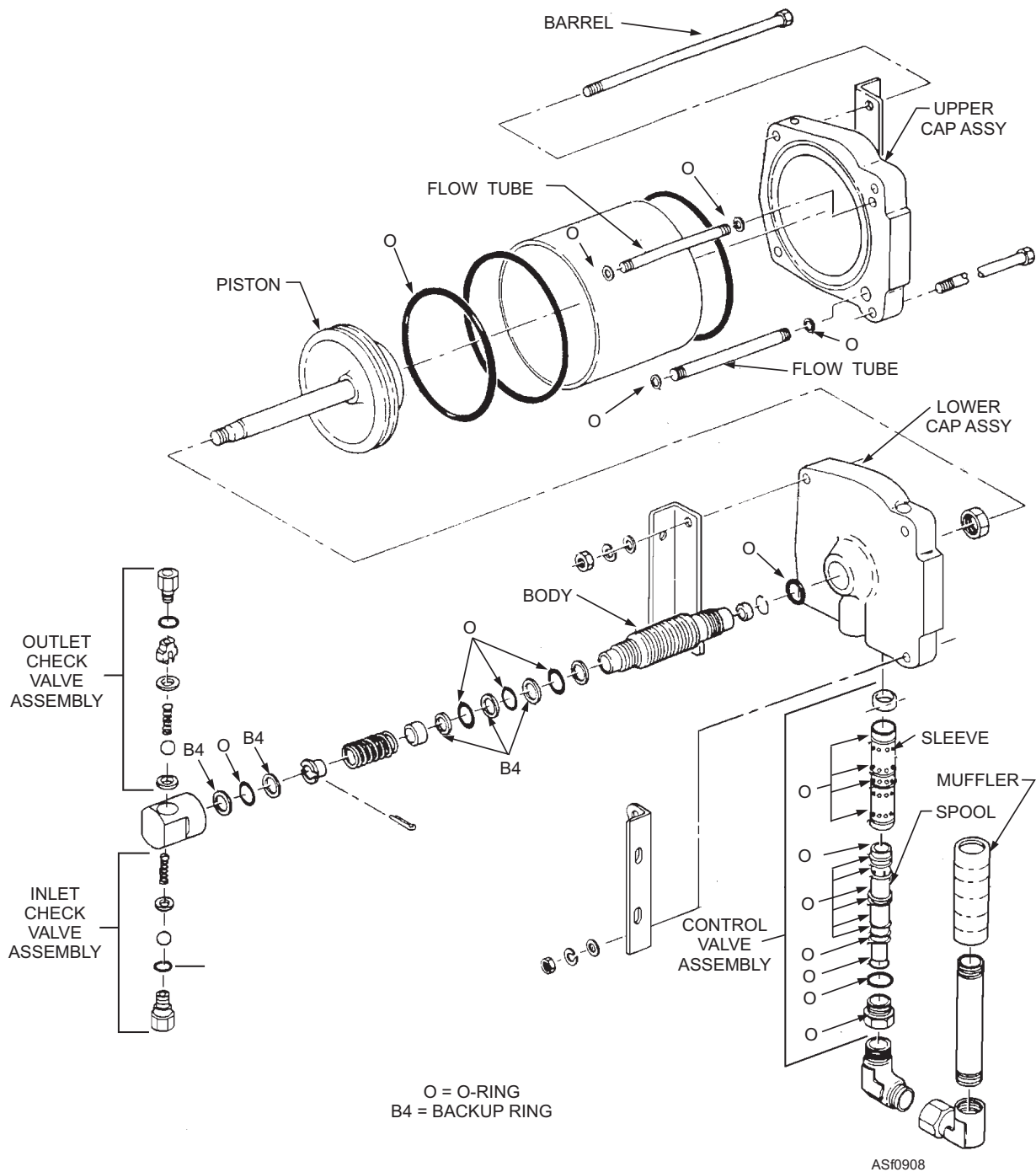

Figure 9-8.—Motor and pump assembly.

NOTE: The number in parenthesis following the component name refers to figures 9-5 and/or 9-6.

RECHARGE VALVE.—The recharge valve (9) controls the flow of nitrogen from a facility source to recharge the cylinders. The servicing hose from the recharge facility attaches to the recharge connection (12). The recharge connection is capped when not in use. A check valve is installed in line with the recharge valve on the cylinder side to prevent reverse flow of nitrogen.

Operation

The A/M26U-4 nitrogen servicing unit is used to service high- and low-pressure nitrogen systems in aircraft and support equipment. These systems include, but are not limited to, struts, accumulators, dampeners, reservoirs, high-pressure tires (over 50 psi), and fire-fighting equipment. The following is a general overview of the operating procedures for the A/M26U-4. Complete and up-to-date operating procedures are included in AG-750AO-OMM-000,

Operation and Maintenance Instructions with Illustrated Parts Breakdown (Intermediate and Depot), Nitrogen Servicing Unit, A/M26U-4. (Refer back to figures 9-5 and 9-6 to locate the components and trace the nitrogen flow.)

WARNING

Always open valves slowly. Servicing hose should be slack when under pressure and should not be stretched to make a connection.

NOTE: The number in parenthesis following the component name refers to figures 9-5 and/or 9-6.

CHARGING AN EXTERNAL SYSTEM.—

Before using the A/M26U-4 to charge a system, you must perform a preoperational inspection on the servicing unit in accordance with its preoperational inspection checklist, AG-750AO-MRC-000. The servicing unit must be positioned sufficiently close to the system to be charged to avoid stretching the servicing hose, and the parking brake must be set. At the start of a charging operation, all valves (2, 4 through 10, and 17) should be closed.

The A/M26U-4 has three modes of operation for charging a system: direct servicing from cylinders G1 through G4; pump operation using nitrogen drive; and pump operation using air drive.

1. Direct Servicing from Cylinders G1 through G4:

NOTE: Open only one green lever control valve at any one time to prevent equalizing cylinder pressure.

- a. Open the green lever control valve (4) of the cylinder with the lowest pressure above the required servicing pressure. Do not use cylinders with less than 200 psi.

WARNING

If leaking is noticed, close the cylinder valve immediately to prevent possible injury to personnel.

- b. Open the manifold shutoff valve (10), allowing nitrogen to flow through the purifier (24) and filter (23) to the manifold gauge (15) and pressure regulator (17).

NOTE: When charging in the range of 0 to 500 psi, observe the low-pressure gauge (13); when charging in the range of 500 to 3,500 psi, observe the high-pressure gauge (14).

- c. Slowly adjust the pressure regulator (17) until the outlet pressure gauge (13 or 14) reads the desired servicing pressure. Nitrogen pressure is now available at the servicing hose valve (2).
- d. Remove the protective cap (22) from the servicing line (1). Firmly holding the end of the servicing line (1), open the servicing line valve (2) slightly to expel any potential contaminants, and then close the servicing line valve (2).

WARNING

Always use an approved remote inflator assembly when charging tires with the nitrogen servicing unit to prevent possible personal injury. NAVAIR 17-1-123 covers the requirements for the remote inflator assembly.

- e. Firmly connect the servicing line (1) to a remote inflator assembly, and connect this assembly to the system being serviced.
- f. Open the servicing line valve (2) and the valve on the system being serviced, and service the system to the desired pressure. If during servicing, the pressure in the servicing unit cylinder drops below 200 psi, close that cylinder lever control valve (4) and open the valve of the next cylinder with lowest usable pressure.
- g. When the desired servicing pressure is reached, close the valve on the system being serviced, and then close the servicing line valve.
- h. After gas has stop venting through the servicing line valve (2), disconnect the remote inflator assembly from the system being serviced. Replace cap (22) on servicing line (1).
- i. Set the regulator for no-flow condition. If no other system is to be serviced immediately, shut down the unit as described in the next section.

2. Pump Operation Using Nitrogen Drive:

NOTE: Open only one red lever control valve at any one time to prevent equalizing cylinder pressure.

- a. Open the red lever control valve (5) of the cylinder with the highest pressure, allowing nitrogen to flow to the pump inlet valve (8).
- b. Open the pump inlet valve (8). This action preloads the nitrogen unit's charging system by allowing nitrogen to flow through the check valves (29), purifier (24), and filter (23) to the manifold pressure gauge (15) and inlet of the pressure regulator (17).
- c. Open the green lever control valve (4) of the cylinder with the lowest pressure above 200 psi, allowing nitrogen to flow to the manifold shutoff valve (10) and the motor inlet selector valve (7). Set the motor inlet selector valve (7) to NITROGEN. This allows nitrogen to flow through the motor regulator (25) to the motor. The motor and pump (19) will begin to cycle. The amount of pressure going to the motor will be displayed on the motor inlet gauge (16). After the nitrogen drives the motor piston, it is expelled to the atmosphere through the muffler (26).

NOTE: The pump will stop cycling automatically when the manifold pressure gauge reaches 3,500 psi, and it will restart when the pressure drops below 3,500 psi. Should the pump slow or stop before the manifold pressure gauge reaches the desired servicing pressure or 3,500 psi, check the pressures of the two open cylinders. If either cylinder is 200 psi or less, close it and open the lever control valve (4 or 5) of the next cylinder with the lowest pressure above 200 psi.

- d. When the desired servicing pressure is indicated on the manifold pressure gauge (15), set the motor inlet selector valve (7) to OFF and close both lever control valves (4 and 5) and the pump inlet valve (8).
- e. Open the manifold shutoff valve (10).
- f. Adjust the pressure regulator (17) to the desired servicing pressure and continue with the servicing operation as previously described.

3. Pump Operation Using Air Drive: Pump operation using air drive is virtually the same as

for pump operation using nitrogen drive. The only difference in procedures is that an air source (usually shop/ship service air) of at least 117 psi is connected to the external air connector (11), and the motor inlet selector valve (7) is set to AIR vice NITROGEN.

NOTE: The number in parenthesis following the component name refers to figures 9-5 and/or 9-6.

SHUTDOWN PROCEDURE.—After servicing an external system, use the following steps to shut down the system. (Refer back to figures 9-5 and 9-6 to locate the components and trace the flow of nitrogen.)

1. Close all six lever control valves (4 and 5).
2. Ensure the regulator (17) is set for no-flow.
3. Ensure the manifold shutoff valve (10) and the pump inlet valve (8) are open.
4. Remove the protective cap (22) from the servicing line (1).
5. Firmly hold the servicing line (1) and slowly open the servicing line valve (2).
6. Set the pressure regulator (17) to flow by turning its knob clockwise.
7. After the manifold pressure gauge (15) and outlet pressure gauges (13 and 14) indicate zero, close the pump inlet valve (8) and manifold shutoff valve (10), and set the pressure regulator (17) for no flow by turning its knob fully counterclockwise.
8. Close the servicing line valve (2), cap the line, and store the hose in the storage box.

NOTE: The number in parenthesis following the component name refers to figures 9-5 and/or 9-6.

RECHARGING THE NITROGEN SERVICING UNIT.— Use the following steps to recharge the unit:

1. Position the trailer near the charging unit.
2. Ensure all valves (2, 4 through 10, and 17) are closed or set for no flow.
3. Open the manifold by-pass valve (6).
4. Open all six lever control valves (4 and 5) from lowest to highest pressure to equalize cylinder pressure.

CAUTION

Ensure that recharging and servicing connections are free of dirt and other contaminants.

5. Firmly attach the recharging hose to the recharge connection (12), and open the recharge valve (9).

NOTE: The pressure regulator on the recharging unit should be set to 3,500 psi.

6. Open the servicing valve of the recharging unit. When all cylinder pressure gauges (3) indicate 3,500 psi, close the recharge valve (9), the manifold by-pass valve (6), and all six lever control valves (4 and 5).
7. Close the servicing valve of the recharging unit, and slowly disconnect the recharging hose to bleed off pressure before removing the connection completely.

Maintenance

Some of the more common repair procedures for the A/M26U-4 nitrogen servicing unit are covered here. This discussion is for training and familiarization purposes only. For actual maintenance of this unit, use AG-750AO-OMM-000, *Operation and Maintenance Instructions with Illustrated Parts Breakdown (Intermediate and Depot), Nitrogen Servicing Unit, A/M26U-4*, and AG-750AO-MRC-010, *Periodic Maintenance Requirements Manual, Nitrogen Servicing Unit, A/M26U-4*.

NOTE: When installing pipe-threaded fittings, antiseize tape (polytetrafluoroethylene) is used to prevent seizure of tapered threads. Do not however, use antiseize tape on fittings with flared or cone-shaped ends. When used, antiseize tape must not extend beyond the first three threads.

MOTOR AND PUMP.—As previously mentioned, two different motor and pump assemblies are used on the A/M26U-4. Different repair kits are available for both types of motor and pump assemblies. Five kits are available for repairing one of the assemblies. You can also order individual O-rings and other parts, but you will normally use one of the repair kits. Before you order a kit or other parts, check the part number of the motor and pump assembly you are working on.

There are few moving parts in the motor and pump. (See figures 9-7 and 9-8.) They include the piston, the two relief valves, and the spool. Of these components, the relief valves seldom fail. The most frequent failures occur in the O-rings. There are several O-rings in the pump and motor, and that means there are lots of places where leaks can occur. Disassembly and repair of the pump and motor is covered in depth in AG-750AO-OMM-000, and you should consult that publication for detailed repair procedures. Our discussion here will focus on replacing O-rings.

When removing O-rings, use proper O-ring removal tools and techniques. If you fail to do so, you may cause more damage than the original problem. If you use improper techniques to remove O-rings, it can cause scrapes and gouges where O-rings come into contact with metal surfaces. These blemishes may then cause cuts, nicks, or scrapes in the O-rings themselves. Any such damage to the O-rings or the metal surfaces they contact can cause incomplete seals. NAVAIR 01-1A-17 gives detailed instructions on how to make proper O-ring removal and installation tools.

During installation, identify each O-ring by part number. Do not rely on physical appearance because many O-rings look alike; however, they differ in size and the material used in construction. While installing O-rings, make sure they are not twisted, installed inside out, or nicked. Backup rings are just as important as O-rings, as they support and hold the O-rings in place. Make sure they are installed correctly. (See NAVAIR 01-1A 17 for more details on backup rings.)

While the pump and motor assembly is disassembled, you should make a complete inspection of all surfaces, not only for scrapes and gouges but for cracks that could cause leaking. After repairs are made, take care in reassembling the pump and motor assembly. Be alert for visible signs of shaved or cut O-ring pieces. If you see such signs, remove the component and reinstall a new O-ring. After the pump and motor assembly is reassembled and reinstalled on the nitrogen servicing unit, pressure-check the unit for leaks and proper pressure output of 3,500 psi.

PRESSURE REGULATOR.—The pressure regulator is one of the few components on the nitrogen servicing unit that is considered repairable. As previously mentioned, two types of regulators are available for use with the A/M26U-4. The most common problem with the older type pressure regulator is a stripped adjusting knob due to improper

operation. The newer type regulator is designed to prevent such an occurrence. Repair kits are available for both types of regulators and should be installed in accordance with AG-750AO-OMM-000. A parts breakdown of a regulator is shown in figure 9-9.

WARNING

Always be sure to release all pressure from the six nitrogen cylinders before disconnecting any tubing. Failure to do so may lead to accidental discharge of high-pressure nitrogen with possible severe injuries to personnel.

If the regulator is not stripped (the most common cause for failure), turn the handle counterclockwise to relieve pressure on the spring and relieve any internal pressure. Loosen the connections slowly, so that any pressure in the system will bleed off slowly. When all the gauges read zero and you hear no further bleed-off noise, disconnect the lines from the unit to the regulator. Then, remove the regulator and place it on a clean workbench for repair. After reassembly, perform a pressure check. Use leak detection compound, MIL-L-25567, to check for leaking.

FILTERS AND PURIFIERS.—Filters and purifiers are normally changed in accordance with periodic maintenance requirements. At times,

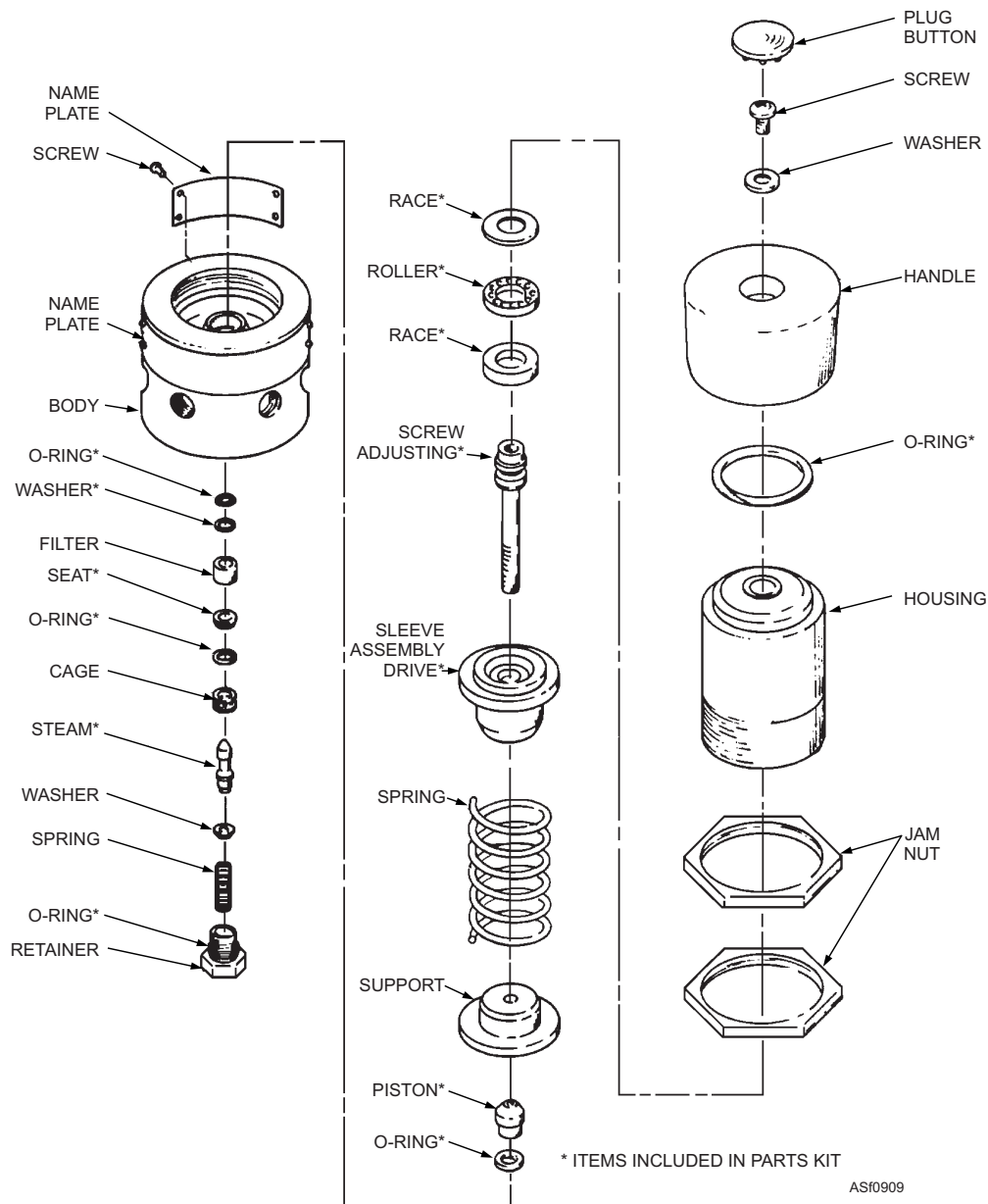

Figure 9-9.—Pressure regulator assembly.

however, they may become contaminated or burst and need to be changed early.

CAUTION

Relieve all pressure from the nitrogen cylinders before disconnecting any tubing and before removing the filter element or purifier cartridge of desiccants. Disassemble only to the extent necessary for replacing defective components.

Changing The Filter.—The filter, shown in figure 9-10, can be removed by unscrewing the bowl and pulling it down. When installing a new filter, install a new O-ring in the bowl. Be careful not to overtighten the bowl. It is the O-ring that makes the seal, not the tightness of the bowl.

Changing The Purifier Cartridge.—When changing the purifier cartridge, shown in figure 9-11, ensure that all pressure is relieved in the system and that all cylinder valves are closed. Replace all O-rings at the time of cartridge replacement.

WARNING

Never attempt to remove or install a purifier cartridge until the unit is properly secured and the components are relieved of pressure. Gases under high pressure, such as are encountered in this equipment, are extremely dangerous to both personnel and equipment if improperly handled.

After installing a new filter and purifier cartridge, you should charge the nitrogen servicing cart and check for leaks with leak detection compound.

VALVES AND OTHER COMPONENTS.—

Most valves on the nitrogen servicing unit are considered not repairable; however, you may have to clean them with an approved cleaning solvent to improve their functionality until a new replacement item can be obtained.

CAUTION

Do not allow dry-cleaning solvent to contact rubber parts, as this causes rubber to deteriorate. Clean all metal parts with dry-cleaning solvent or carbon tetrachloride. Remove hard crust and minor corrosion with a bristle brush dipped in dry-cleaning solvent. Then, wipe dry with a clean, lint-free cloth or dry with compressed air.

Cracked lines are a common problem, and nuts often become corroded. After valves have been repeatedly opened too fast, a burst of high-pressure nitrogen may cause a device to fail from the surge in pressure. Extreme cold or heat can also take a toll. Oddly enough, the most severe source of heat isn't the sun, but jet exhaust. Occasionally, taxiing jet aircraft will stop in a position where the jet exhaust is pointing toward a servicing cart. The rapid expansion of metal due to heating may cause a crack to develop.

NOTE: *Fluid Power*, NAVEDTRA 14105, contains a detailed discussion on the fundamentals of

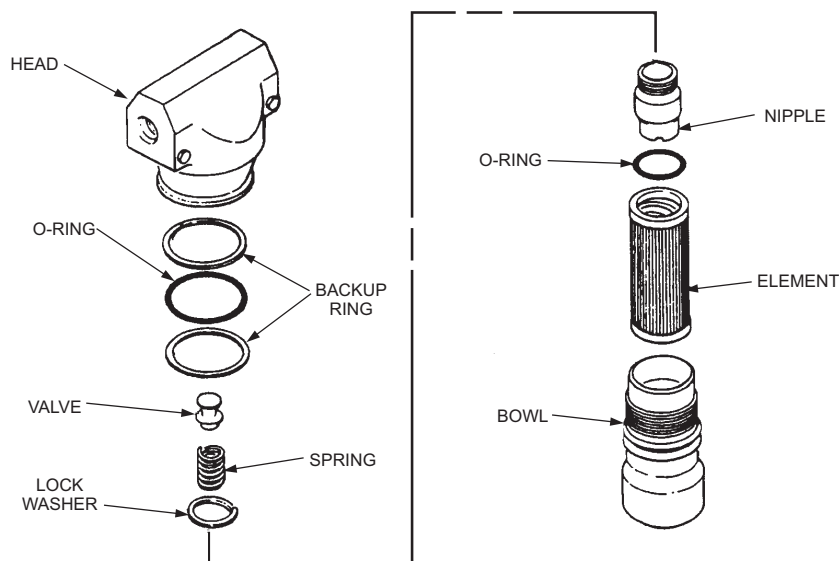

AS109010

Figure 9-10.—Filter assembly.

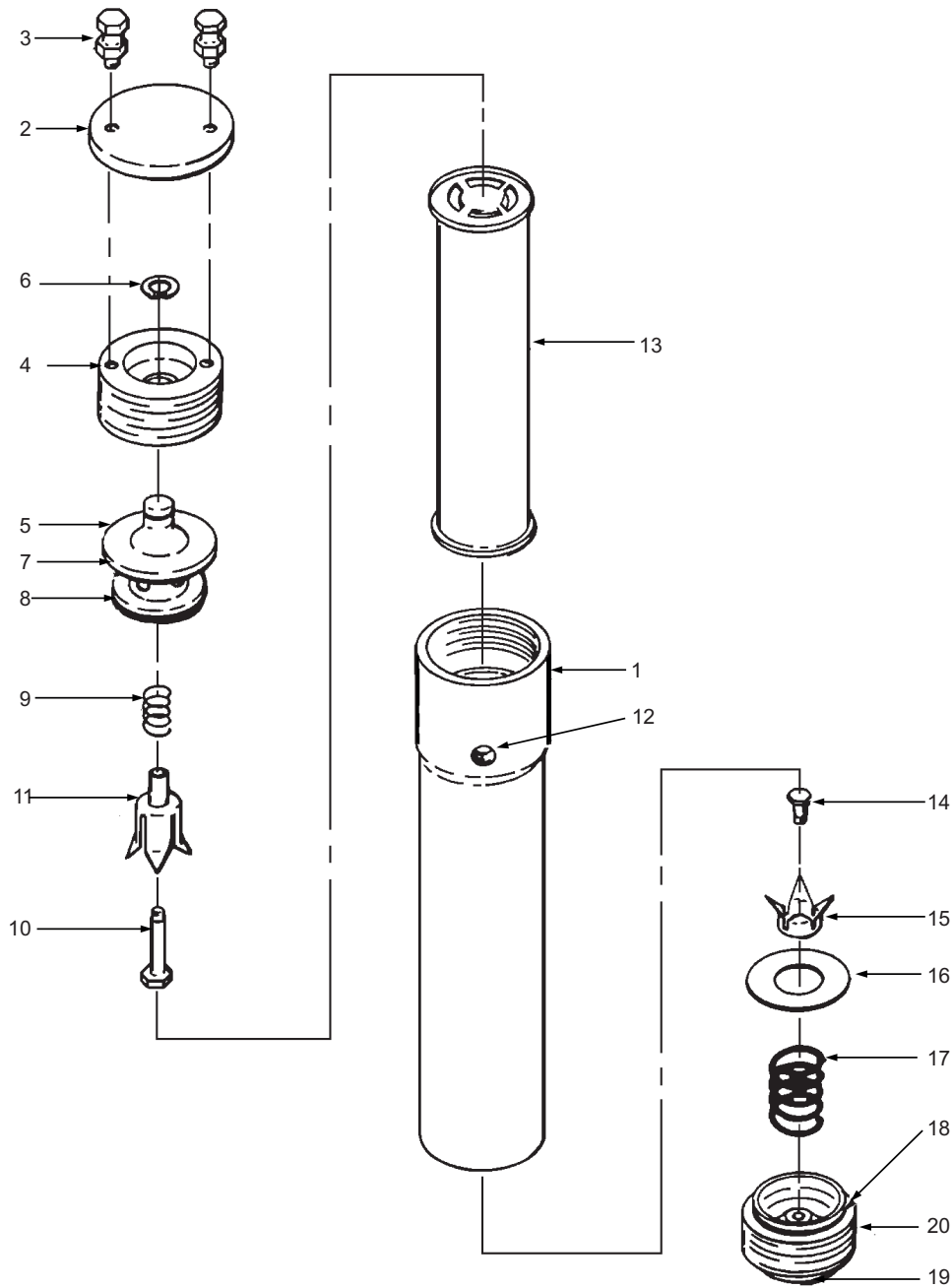

ASf0911

- | | |
|--------------------------|-------------------------------|
| 1. Cylinder | 11. Upper perforator assembly |
| 2. Head cover | 12. P-28A pipe lug caplug |
| 3. Stud | 13. Desiccant cartridge |
| 4. Upper head | 14. Lower retaining screw |
| 5. Lower head | 15. Lower perforator |
| 6. Retaining ring | 16. Lower perforator plate |
| 7. O-ring | 17. Perforator lower spring |
| 8. O-ring | 18. O-ring |
| 9. Upper spring | 19. P-28A pipe lug caplug |
| 10. Upper shoulder screw | 20. Tail piece |

Figure 9-11.—Purifier assembly.

pneumatics and the operation of the various types of components found in fluid power systems. We recommend that you refer to this manual if any of the terms or devices are not clear to you.

Troubleshooting

Table 9-2 lists some of the more common troubles, probable causes, and remedies for repairing or

Table 9-2.—A/M26U-4 Troubleshooting Chart

Trouble	Probable Cause	Remedy
Motor and pump do not operate.	Motor selector valve is not properly positioned. Leak in the gas system. Defective seals in between compressed gas and driving gas sections.	Properly position valve. Tighten all fittings. Replace seals.
Pump will not cycle or cycling is slow.	Gas supply is inadequate. Vent or outlet line is blocked. Leaking at flow and/or pilot tubes. Pilot valve(s) are malfunctioning. Buildup of residue in the muffler. Defective piston.	Check to ensure gas supply to inlet is adequate. Check for blocked vent or outlet line. Replace O-rings on flow and pilot tubes. Some units may require two O-rings at the ends of the tubes. Repair pilot valve(s). Clean or replace muffler. Replace motor and pump.
Motor and pump will not operate at low gas drive pressures.	Excess friction of spool packings of the control valve.	Repair, making certain that spool O-rings are lubricated.
Pump will not build up pressure.	Defective pump O-rings. (If gas supply is meager, exhaust bleeding will be continuous.)	Replace O-rings in following order: a. Spool O-rings b. Piston O-rings c. Sleeve O-rings, if leaking persists
Pump cycles erratically.	Pilot valve is leaking.	Repair pilot valves with Kit 27420.
Excessive moisture outside of muffler.	Filter is full of water.	Drain filter.
Excessive leaking out of vent.	Rod seals are worn.	Replace gas section seals.
Lever control valve leaks.	Faulty diaphragm.	Replace.
Tire and tube leaking.	Valve is leaking. Tube is punctured.	Replace valve core. Repair or replaces.
Service hose leaking.	Hose coupling nuts are loose. Hose is split.	Tighten coupling nuts. Replace hose.
Purifier leaking.	Purifier head is loose. Defective O-rings.	Tighten purifier head. Replace O-rings.
Pressure regulator leaking.	Regulator piston is leaking.	Repair regulator.
Hose and tube assemblies leaking.	Coupling nuts are loose.	Tighten coupling nuts.
Pressure regulator does not deliver charging pressure.	Pressure in cylinders is too low. Regulator is defective.	Recharge cylinders. Repair/replace regulator.

replacing components on the nitrogen servicing unit. As noted earlier, the charts in this manual do not cover all of the possible problems you may encounter. For complete coverage of troubleshooting, consult the appropriate service manuals.

Safety

The following precautions must be observed during operation and maintenance of nitrogen servicing units.

- Never use your hands to feel for leaks in high-pressure nitrogen components or plumbing. An invisible, high-pressure leak can act like a sharp knife and penetrate the skin or even sever a finger.
- Safety chains are provided at the front of the nitrogen servicing unit and are to be used for breakaway only, not for towing the trailer.
- Only licensed, qualified operators should operate the nitrogen servicing unit.
- Do not allow oil, grease, or readily combustible materials to come in contact with cylinders, valves, regulators, gauges, or fittings.
- Inspect the servicing hose and fittings of the system to be charged before servicing. Carefully remove any traces of oil, grease, or contaminants.
- Always bleed the servicing line to ensure that it is free of all foreign matter before connecting it to the system to be charged.
- Open all valves slowly. Adjust the pressure regulator in small increments. Avoid the danger of rapid charging.
- Open the manifold bypass valve only when recharging cylinders or when air drive is being used.
- Before commencing a servicing operation, determine the pressure of the system to be charged.
- Because of the dangerously high pressures used, do not, under any circumstances, substitute any components of this system with those of other systems. This includes the stainless steel fittings used throughout the plumbing.
- Do not use high-pressure nitrogen to power low-pressure pneumatic tools or support equipment.
- Do not charge this system with oxygen or interchange components with oxygen components. To do so may produce an explosion.
- Because of the oil contamination that may be contained in nitrogen servicing units, do not use them for purging oxygen systems. For that purpose, use the Aircraft Liquid Oxygen System Gas Purging Set, Part Number 900001-1.
- Never back out on the regulator to relieve pressure until the hose valve has been secured.
- Always check the hydrostatic test dates of the nitrogen cylinders to ensure that they have not been in service for more than 5 years.
- Never stretch a servicing line to reach a connection. Position the trailer so that the servicing line is not under tension.
- Never service a system without using an approved remote inflator between the hose and the system being serviced. Ensure that the remote inflator is within its calibration cycle.
- Before disconnecting the servicing line from a fitting, bleed the line by turning the servicing line valve to the BLEED position.
- In locations where inside storage space is available, stow the servicing trailer inside. When inside storage is impractical, fabricate a canvas cover to protect the manifold, panel, and component assemblies. Properly stow the servicing line in the stowage box.
- Nitrogen should not be discharged in large quantities into closed compartments unless adequate ventilation is provided.
- When moving the trailer from place to place, close the cylinder valves, stow the servicing line, and release the hand brake.

LOW-PRESSURE AIR COMPRESSORS

Low-pressure air from ships' compressors or shop-installed compressors is the most common source of compressed air in the work center. Compressed air is used to dry parts, run pneumatic tools, service low-pressure tires, and even drive pneumatic-powered support equipment, such as hydraulic check and fill stands, dry honing machines, floor jacks, and paint sprayers. Remember that when an air separator is not in use, compressed air normally

contains oil and significant amounts of water. This limits your use of compressed air. For example, you can't use it to purge oxygen equipment because of oxygen purity standards and because mixing oil with oxygen is an explosion hazard. You will learn more about this in the next chapter.

Cylinders for compressed air are painted black. Those containing oil-pumped air have two green stripes painted around the top of the cylinder; those containing water-pumped air have one green stripe. A cylinder's last hydrostatic test date is stenciled across the bottom of the cylinder.

Low-pressure air from portable, engine-driven, support equipment is oil-pumped and has a high moisture content. It cannot be used as a substitute for low-pressure nitrogen.

Q9-6. What is the maximum operating pressure that can be obtained from a portable nitrogen cylinder?

1. 2,400 psi
2. 2,800 psi
3. 3,000 psi
4. 3,500 psi

Q9-7. What is the total number of nitrogen cylinders on the A/M26U-4 nitrogen servicing trailer?

1. One
2. Two
3. Five
4. Six

Q9-8. What is the maximum pressure allowed for a nitrogen bottle on the A/M26U-4 nitrogen servicing trailer?

1. 2,400 psi
2. 3,000 psi
3. 3,500 psi
4. 4,000 psi

Q9-9. Which of the following valves is used only when recharging the cylinders on the A/M26U-4 nitrogen servicing trailer?

1. The manifold by-pass valve
2. The manifold shutoff valve
3. The lever control valve
4. The pump inlet valve

Q9-10. Which of the following gauges is NOT a gauge used on an A/M26U-4 nitrogen servicing trailer?

1. The manifold pressure gauge
2. The low pressure output gauge
3. The high pressure output gauge
4. The manifold by-pass gauge

Q9-11. What is the minimum pressure that should remain in a nitrogen cylinder on an A/M26U-4 nitrogen servicing trailer?

1. 50 psi
2. 200 psi
3. 500 psi
4. 750 psi

Q9-12. The pump on the A/M26U-4 nitrogen servicing trailer will stop automatically when the manifold pressure reaches what maximum pressure?

1. 2,500 psi
2. 3,000 psi
3. 3,500 psi
4. 3,750 psi

Q9-13. In the motor and pump assembly, which of the following components are least likely to fail?

1. Pressure regulator
2. Relief valves
3. Piston
4. Spool

Q9-14. Which of the following discrepancies could be a probable cause for the pump not cycling or cycling slow?

1. Defective piston
2. Motor selector valve improperly positioned
3. Rod seals are leaking
4. Defective spool

Q9-15. The hydrostatic test dates of the nitrogen cylinders should not exceed what number of years?

1. 5
2. 3
3. 7
4. 10

Q9-16. Cylinders containing compressed air that has been oil-pumped have which of the following color schemes?

- 1. They are black with two green stripes*
- 2. They are black with two yellow stripes*
- 3. They are black with two red stripes*
- 4. They are black with two white stripes*

CHAPTER 10

LIQUID AND GASEOUS OXYGEN SYSTEMS AND EQUIPMENT

INTRODUCTION

As an Aviation Support Equipment Technician, you will be responsible for maintaining oxygen handling equipment. To do so, you will have to be able to operate the equipment as well as perform preventive and corrective maintenance procedures. This course covers the properties of liquid and gaseous oxygen, storage devices, equipment for delivering oxygen to the users, and safety procedures for protecting the equipment and yourself.

OXYGEN

LEARNING OBJECTIVES: Identify the properties of liquid and gaseous oxygen. Identify procedures for preventing contamination to liquid and gaseous oxygen systems. Identify safety procedures for liquid and gaseous oxygen systems.

Oxygen is a colorless, odorless, tasteless gas that makes up about 21 percent of the atmosphere. The rest of the atmosphere is made up of nitrogen (78 percent) and inert gases (1 percent). Although oxygen is found in many compounds, such as water, limestone, sand, and iron ore, it occurs as free oxygen only in the atmosphere. It can also exist as a solid or liquid (LOX), depending upon the temperature and pressure to which it is subjected. Of all the elements in our environment, oxygen is the most plentiful.

Oxygen is a very reactive material because it will combine with most other chemical elements. The union of oxygen with another substance is called *oxidation*. Some examples of oxidation are rusting of iron, drying of paints, and the changing of alcohol into vinegar.

Oxidation normally produces heat. Extremely rapid or spontaneous oxidation is called *combustion*. Usually, the heat from oxidation is dissipated fast enough that temperatures do not rise significantly. If, however, heat is given off so rapidly that it does not have time to be dissipated, the temperature may rise so high that spontaneous combustion occurs. While

oxygen itself is not combustible, it strongly supports and rapidly accelerates the combustion of all flammable materials, some to an explosive degree. If compressed oxygen becomes mixed with hydrogen or grease, for example, the combination becomes highly explosive. You should NEVER allow combustible material to come into contact with compressed oxygen.

Probably the most important property of oxygen is that it is the element in air that supports life. If the right amount of oxygen is not present in the atmosphere, people, animals, insects, and most bacteria cannot live. In high-altitude flying or in confined spaces, it is necessary to supply air for breathing from some outside source. Therefore, one of the important uses of oxygen in the Navy is to furnish a supply to people who would otherwise face a lack of oxygen.

NOTE: Some of the tasks presented in this course, such as filling an aircraft LOX converter, are not normally performed by an Aviation Support Equipment Technician. However, the tasks are included here on the assumption that to fix the equipment, you have to know how it works.

Q10-1. What is the term used for rapid or spontaneous oxidation?

1. *Combustion*
2. *Explosion*
3. *Erosion*
4. *Flash corrosion*

Q10-2. Which of the following type of materials should you NEVER allow compressed oxygen to come into contact with?

1. *Liquids*
2. *Solids*
3. *Biodegradable*
4. *Combustibles*

LIQUID OXYGEN (LOX)

LEARNING OBJECTIVES: Identify the components of liquid oxygen systems. Recognize the working relationships among

liquid oxygen system components. Identify procedures for inspecting, checking, cleaning, testing, and adjusting liquid oxygen system components. Identify procedures for troubleshooting liquid oxygen systems. Identify procedures for repairing, removing, and replacing liquid oxygen system components.

At atmospheric pressure, gaseous oxygen becomes liquid when it is cooled below its boiling point of -297°F (-183°C). By increasing the pressure under which it is stored, oxygen can be liquefied at higher temperatures. Above the critical temperature of -182°F (-119°C), oxygen will not condense to a liquid regardless of how much pressure is applied. The application of high pressure and low temperature to convert gases into their liquid states is the science and technology of cryogenics. LOX is a cryogenic fluid. Figure 10-1 is a chart that compares important temperatures of LOX to those of other liquids.

LOX is a pale blue, nonviscous fluid that flows like water. One gallon of LOX weighs 9.527 pounds, which

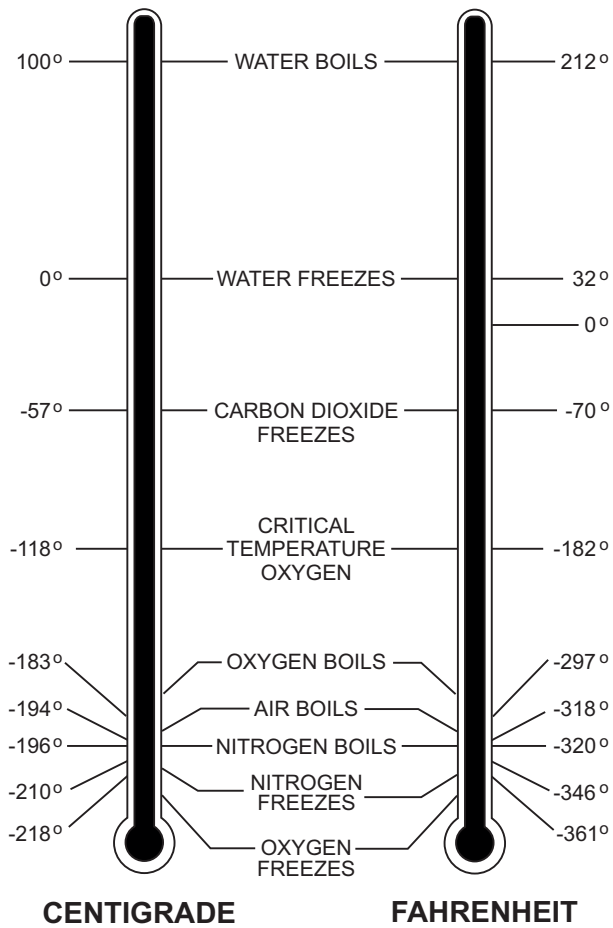

Figure 10-1.—Comparative temperature chart. ASF10001

is about 1.14 times as heavy as the same volume of water. LOX, when warmed to ambient temperatures (about 70°F), expands to about 862 times its liquid volume. If you confine a cubic foot of LOX in 1 cubic foot of space, and allow it to warm past its critical temperature, it will exert an explosive pressure of about 12,000 pounds per square inch. That is roughly 6 tons of pressure on each square inch of surface area. For this reason, LOX storage containers are fitted with pressure-relief devices.

For Navy use, LOX is stored and handled at atmospheric pressure in well-insulated containers that maintain the liquid at its boiling point. Such containers are vented to the atmosphere to prevent the constantly evaporating LOX from building up to a dangerously high pressure.

LIQUID OXYGEN STORAGE

On naval air stations, liquid oxygen is centrally stored in large storage tanks, generally 2,000 gallons or less. These tanks are designed to store the LOX at atmospheric pressure, with low evaporation losses. Users of LOX then draw their supplies from these tanks. The design features and practices described in this chapter apply to all capacities, but the main emphasis here is on tanks of 2,000 gallons or less. Figure 10-2 shows a typical 2,000-gallon-capacity storage tank.

Storage Tanks

All LOX storage tanks are basically similar, regardless of their size or configuration, regardless of whether they are skid-mounted, trailer-mounted, or permanently installed. All tanks consist of inner and outer containers separated by an insulated space that is

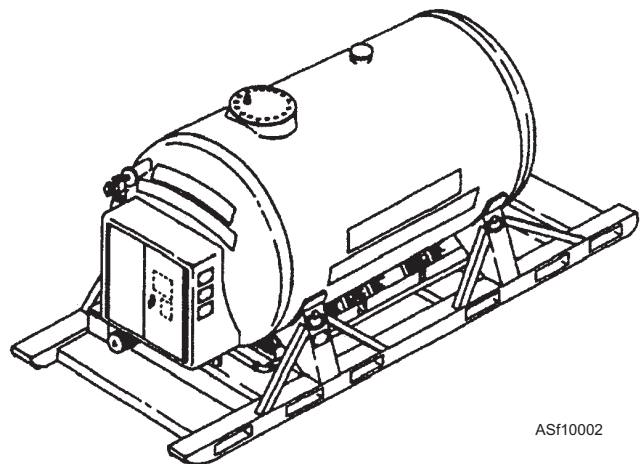

Figure 10-2.—2,000 gallon capacity liquid oxygen storage tank. ASF10002

packed with a powder-type insulating material. The space is evacuated to a high degree to minimize heat transfer and to hold evaporation losses to a minimum.

Transfer Lines

Other than large, fixed-facility piping, most liquid oxygen systems consists of segmented flexible transfer lines. The lines are segmented for ease of demounting, so that one transfer system can service different types of equipment. The most common type of line used in the field is corrugated, flexible, metal hose (fig. 10-3), which is constructed of bronze, stainless steel, or aluminum. The bayonet coupling shown in figure 10-3 is used to connect the service line to an aircraft LOX converter.

On a typical day lines are cooled and warmed many times as LOX is drawn from the tanks. The waste of LOX due to cool down losses can be significant. For this reason, transfer lines, like storage tanks, are as well insulated as possible. Hoses are double-walled

(called *vacuum-jacketed*), with point-contact space rings to prevent the inner liquid-bearing line from touching the outer jacket wall. To keep the heat influx as low as possible, low thermal conductivity materials are used for insulation, and the spacer design provides for as small an area of contact between the inner and outer walls as possible.

Flexible hose is more vulnerable to damage than its rigid counterpart. To strengthen flexible hoses, they are built with braided metallic coverings or tough plastic sheaths over the external corrugations. Although such protection provides a degree of reinforcement, it cannot entirely overcome the effects of rough handling. Hoses are tough, but not indestructible.

Over pressurization of oxygen hoses is another condition to be avoided. Over pressurization may produce a bellows-like effect if the covering is not securely fastened at the end connections. This may cause separation of the outer cover at the hose collar,

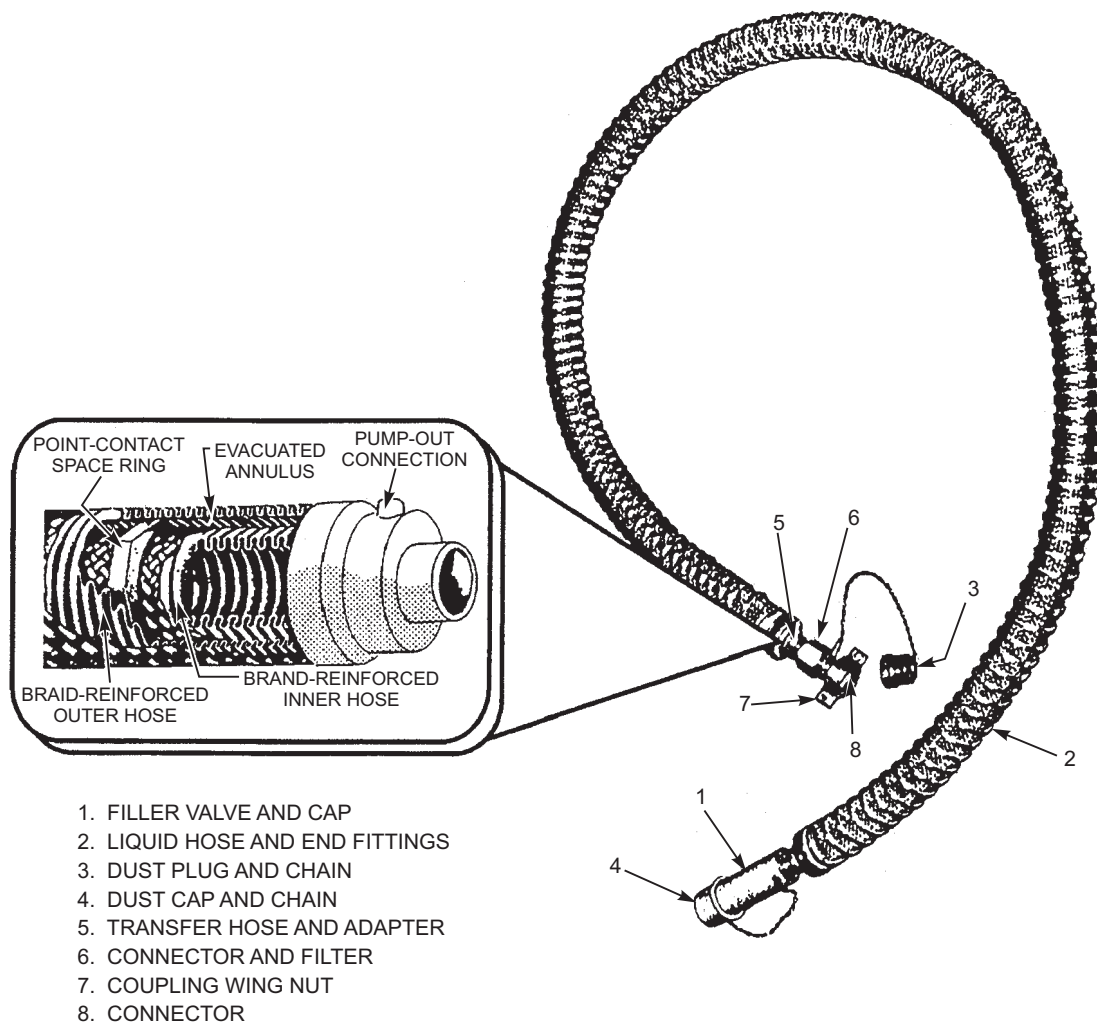

Figure 10-3.—Corrugated flexible metal hose.

ASf10003

breaking the vacuum. Over pressurization also expands the hose axially, causing it to grow by lengthening the distance between corrugations. This makes the line less flexible (in much the same way a charged fire hose gets stiff) and can possibly lead to breaking the seal between the joints.

Another important consideration is to never allow liquid to be trapped in a line between closed valves, unless there is a relief device, such as a pressure-relief valve, protecting the inner line. Trapped liquid vaporizes, warms, and exerts excessive pressure on the walls of the line.

As another consideration, you should avoid coupling two or three transfer sections together where one will do the job. If you use more hose than is required, more line material has to be cooled and more liquid is lost to vaporization. If that happens, more liquid is required to satisfy a given transfer demand.

Valves

Low-temperature valves used in LOX systems often cause more trouble than any other element of the system. Liquid oxygen valves must be able to function properly at extremely low temperatures without causing excessive boil-off losses. The best method for meeting the thermal considerations for such valves is through insulation. Several materials have been used for insulation, but the most effective method is to vacuum-jacket the valve. The valve illustrated in figure 10-4 is typical of this type.

LIQUID OXYGEN SERVICING TRAILERS (LOX CARTS)

LOX carts are used to service oxygen converters used in naval aircraft. Although there may still be some older carts in use at some activities, the two most commonly used LOX carts are the TMU-27/M and the TMU-70/M, shown in figure 10-5.

The TMU-27/M LOX cart is called a *standard trailer*. Standard trailers vent gaseous and liquid oxygen overboard through the vent fitting of the LOX converter as it is being filled. The TMU-70/M, on the other hand, is called a *low-loss, closed-loop (LLCL)* trailer. It recaptures the vented gases and returns them back to the storage tank for recovery.

The TMU-27/M has a long service hose so it can service aircraft LOX converters in the aircraft. The TMU-70/M, on the other hand, has a short service hose

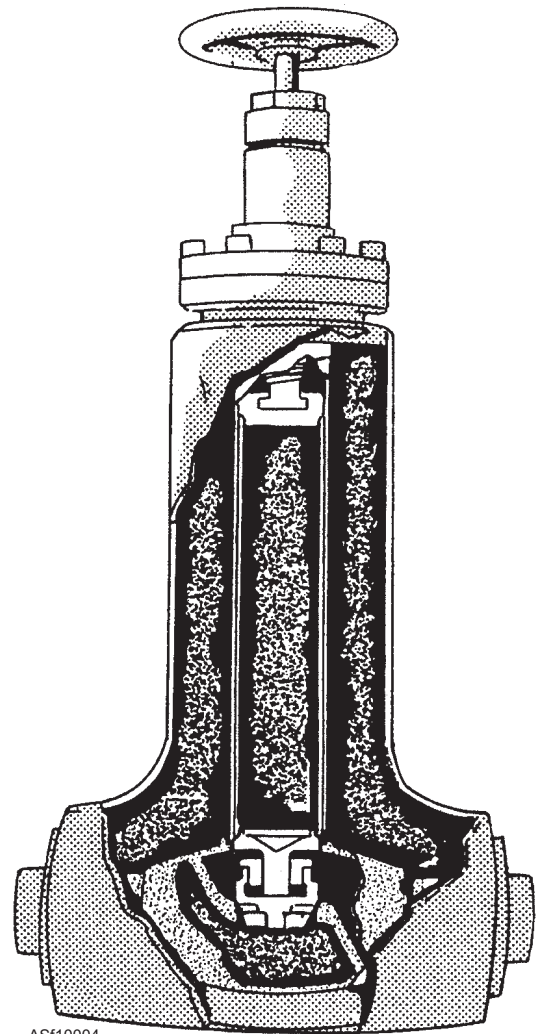

Figure 10-4.—Vacuum insulated cryogenic globe valve.

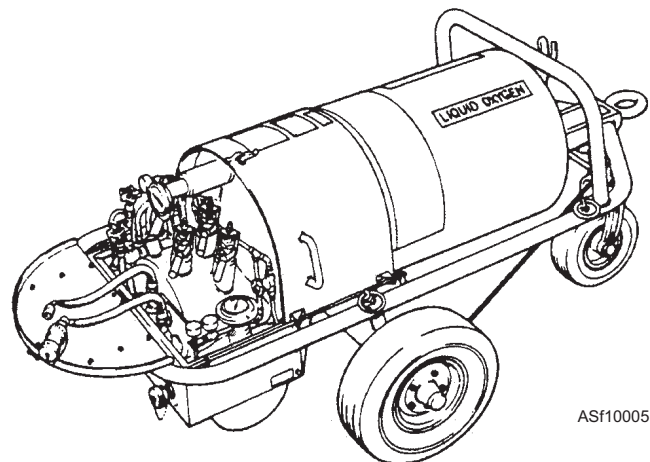

Figure 10-5.—TMU-70/M low-loss, closed-loop, liquid oxygen servicing trailer.

and can only service converters that have been removed from the aircraft.

The TMU-70/M LOX servicing trailer, shown in figure 10-5, is manufactured by the Cryogenic

Engineering Company. This cart has been selected for coverage in this training manual because it is the most common and it is also the only one with the low-loss, closed-loop system.

During servicing of aircraft LOX converters with standard LOX trailers, considerable loss of oxygen occurs as a direct result of venting overflow into the environment. This also creates a considerable safety hazard due to releasing liquid oxygen and oxygen vapors into the atmosphere near operating equipment and personnel. The TMU-70/M low-loss, closed-loop

(LLCL) system was designed to alleviate these problems. The TMU-70/M significantly reduces liquid oxygen transfer losses and virtually eliminates the safety hazards associated with venting oxygen in critical areas. In the brief discussion that follows, refer to figure 10-6, which is a functional schematic of the LOX servicing trailer.

The TMU-70/M is a completely self-contained unit. It has three major components: a 50-gallon dewar tank, a 15-liter dewar transfer tank, and a low-loss, closed-loop (LLCL) system of transfer lines. (A dewar

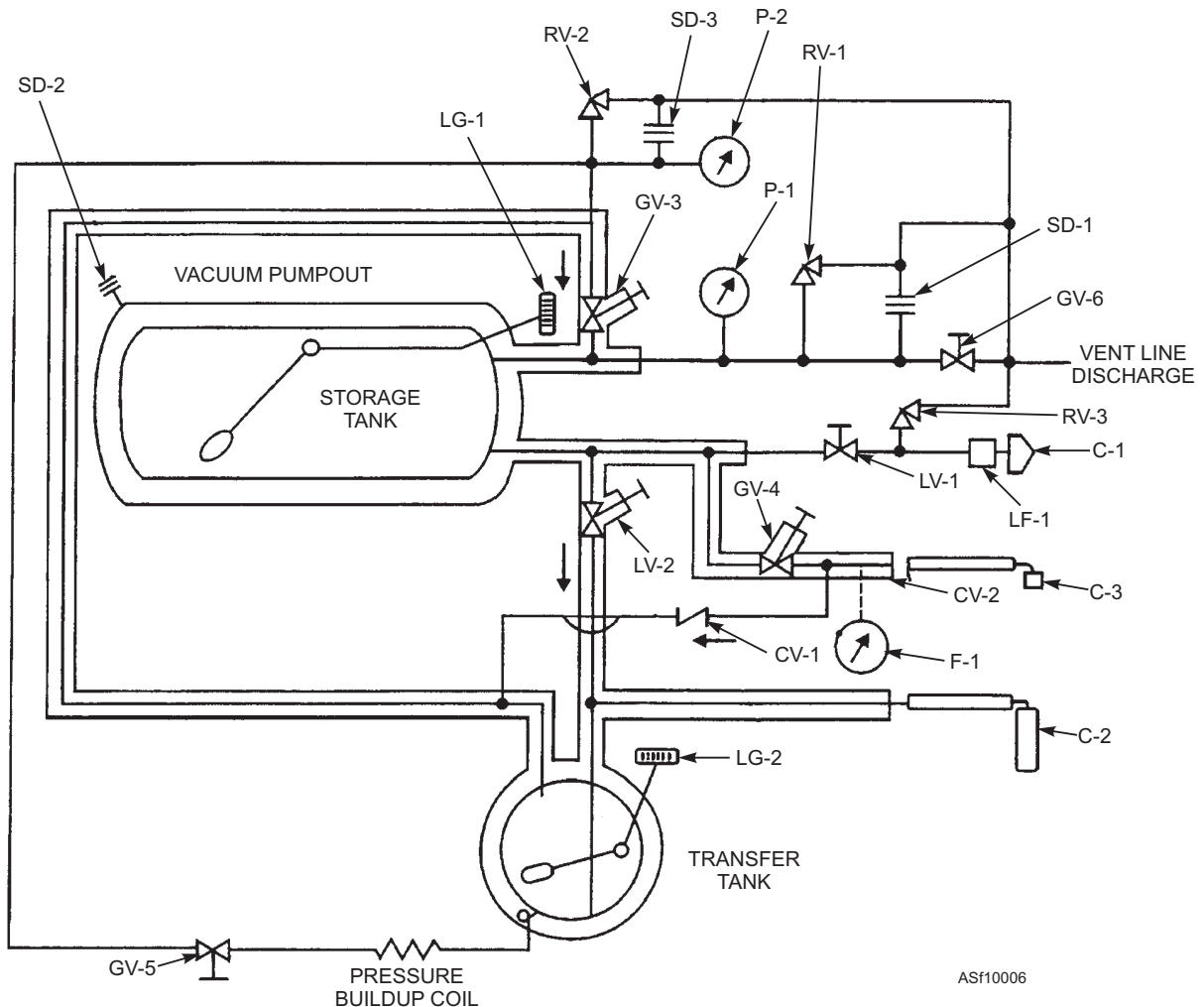

- | | | | |
|------|---------------------------------------|------|--|
| C-1 | Fill-drain line coupling | LG-2 | Transfer tank liquid level gauge |
| LF-1 | Fill-drain line filter | RV-2 | Transfer tank inner shell relief valve |
| LV-1 | Fill-drain line shutoff valve | SD-3 | Transfer tank inner shell rupture disc |
| RV-3 | Fill-drain line relief valve | C-3 | Converter vent line connector |
| GV-6 | Storage tank vent line shutoff valve | C-2 | Filler valve |
| LG-1 | Storage tank liquid level gauge | CV-1 | Converter vent line check valve |
| P-1 | Storage tank pressure gauge | F-1 | Converter full indicator gauge |
| RV-1 | Storage tank inner shell relief valve | GV-4 | Converter vent line shutoff valve |
| SD-1 | Storage tank inner shell rupture disc | GV-5 | Transfer tank pressure buildup valve |
| LV-2 | Transfer tank fill line shutoff valve | SD-2 | Outer shell relief device |
| GV-3 | Transfer tank vent line shutoff valve | CV-2 | Converter vapor return check valve |
| P-2 | Transfer tank pressure gauge | | |

Figure 10-6.—LOX servicing trailer schematic diagram.

tank is one with a vacuum space between two walls.) Separate liquid level and pressure gauges, as well as pressure-relief devices, are provided for each tank. These components are permanently mounted on a portable three-wheel trailer, which is equipped with a manually operated parking brake and retractable caster wheels.

The low-loss, closed-loop transfer system is designed to retain oxygen vapor caused by heat losses during transfer to the aircraft converter. The gaseous oxygen vapors vented from the transfer tank and aircraft converter are returned to the storage tank for cool down and retention.

The Storage Tank

The storage tank is a 50-gallon (U.S.) capacity, and the space between the double walls of the storage tank and the transfer tank is evacuated down to 5 microns or less. The space between the walls also contains a multi-layer, high-vacuum insulation to minimize heat gain and boil-off of the liquid oxygen.

The Transfer Tank

The 15-liter-capacity transfer tank is a double-walled, vacuum-insulated dewar that is permanently attached to the storage tank. The transfer tank is self-contained, and is gravity-filled from the storage tank. The transfer tank has a pressure buildup coil, a relief valve, a rupture disc, and various controls. The primary function of the transfer tank is to hold small volumes of liquid oxygen and to use cold gas pressure from the pressure buildup unit to transfer LOX from the cart to the aircraft's LOX converter.

The Transfer Lines and Piping System

The LOX cart's transfer lines carry LOX from the storage tank to the transfer tank, and then to the aircraft's LOX converter. The lines also carry vented oxygen gas from the aircraft's LOX converter back to the storage on the cart tank.

The closed-loop system of the transfer lines contains vented oxygen gas during filling operations. The interconnected liquid and return gas lines are vacuum-jacketed wherever practical, and are of minimum length to reduce cool down and heat leak losses.

The piping system consists of a fill line for filling the storage tank, a vent system for overboard venting of

excess liquid or gas, and a pressure-relief valve system that is connected to the vent system.

Transfer of LOX from the cart to the aircraft LOX converter is by pressure differential. Basically, a higher pressure is built in the LOX cart than what exists in the aircraft converter. Pressure in the cart is developed by allowing LOX to flow into the buildup coil. The buildup coil acts as a heat exchanger, changing liquid into gas through vaporization. The gaseous product fills the area, causing pressure within the storage tank or transfer tank. When the pressure in the cart becomes greater than the pressure in the aircraft's system, the transfer of LOX takes place.

Controls and Indicators

Table 10-1 contains functional descriptions of the components outlined previously in figure 10-6. Figure 10-7 shows the physical layout of the controls and indicators. Refer to figures 10-6 and 10-7 and to table 10-1 as we describe how the system works and which controls affect which functions. Note how LOX and gas vapors flow in the system. Troubleshooting and maintenance will be easier if you can see the big picture of how the system works, and which controls affect which functions.

With the exception of the converter full indicator gauge (marked LIQUID or GAS) and the transfer tank liquid level gauge, all gauges have a green band to indicate safe operating pressures and a red band to indicate unsafe pressures.

The pressures of internal systems used to fill and service converters, and to protect LOX carts and LOX cart operators, are listed in table 10-2.

Filling the Servicing Trailer

In most locations, servicing trailers are filled from central supply tanks called LOX farms. The supply tanks have transfer hoses terminating in couplings that match the fill-drain line couplings on the trailers. For the correct operating procedures for the supply tanks, refer to the tank's operations manual. LOX farm operators will prepare the station's supply tank to transfer LOX to the servicing trailer.

In studying the procedure for filling a servicing trailer, refer to figures 10-6, 10-7, and table 10-1. When the supply tank is ready, use the following procedures to fill the servicing trailer:

NOTE: Before starting this procedure, be sure to don all of the appropriate safety clothing.

1. Ensure that all control valves are closed, except for the storage tank vent valve (GV-6).

LV-1: The fill-drain line shutoff valve

LV-2: The transfer tank fill line shutoff valve

GV-3: The transfer tank vent line shutoff valve

GV-4: The converter vent line shutoff valve

GV-5: The transfer tank pressure buildup valve

2. Ensure that the trailer is level, the caster is down and locked, and that the parking brake is set.

3. Place a clean, oil-free drip pan under the vent valve.

4. Remove the dust covers from the supply tank's transfer line, and purge the hose. (Purging the hose means to allow liquid LOX to flow through the hose, cooling it until only liquid passes through, and no vapor.)

5. Connect the purged transfer hose to the fill-drain line coupling (C-1) on the servicing trailer.

6. Open the servicing trailer's storage tank fill-drain line shutoff valve (LV-1).

7. Slowly open the service valve on the supply tank, allowing only a partial flow of LOX through the transfer hose and into the trailer. (Considerable vaporization will take place until the transfer hose, fill-drain line, and storage tank of the servicing trailer have cooled down.)

CAUTION

Monitor storage tank pressure gauge P-1 closely during cool down. Do not allow pressure in the storage tank to rise above 50 psi.

8. Monitor the storage tank liquid level gauge (LG-1) during filling. When the gauge reads 50 gallons, or LOX starts to flow out of the vent manifold, close the service valve on the supply tank.

9. Close the fill-drain line shutoff valve (LV-1).

10. Open the supply tank transfer hose vent valve, and disconnect the supply tank transfer hose from the servicing trailer.

11. Immediately drain the LOX that remains in the supply tank transfer hose, and loosely replace the coupling cap. Tighten the cap only after all LOX has vaporized and bled off.

WARNING

Use extreme caution when disconnecting the transfer hose. Even though the hose has been drained and the pressure relieved, some LOX will still remain. Do not direct the hose toward personnel or other equipment.

12. Ensure that all control valves on the servicing trailer are closed, except for the storage tank vent line shutoff valve (GV-6).

Filling of the storage tank is now completed.

Table 10-1.—LOX Servicing Trailer Controls and Indicators

Code	Component Name	Description of Function
C-1	Fill-Drain Line Coupling	Filling and draining point for the storage tank.
LF-1	Fill-Drain Line Filter	Prevents particles from flowing into the storage tank during filling.
LV-1	Fill-Drain Line Shutoff Valve	Controls the flow of LOX into the storage tank during filling. Also used to drain the storage tank.
RV-3	Fill-Drain Line Relief Valve	Prevents excessive pressure buildup if the fill-drain line shutoff valve and service valve of the central supply tank are closed with cold gas or liquid trapped within the supply line.
GV-6	Storage Tank Vent Line Shutoff Valve	Opened during filling and normal storage where overboard discharge is available and safe. Normally closed during short ground transportation.

Table 10-1.—LOX Servicing Trailer Controls and Indicators—Continued

Code	Component Name	Description of Function
LG-1	Storage Tank Liquid Level Gauge	Indicates the liquid level in the inner tank when the tank is situated on level ground. The dial is magnetically and mechanically coupled to a float sensor inside the storage tank, and is calibrated in gallons.
P-1	Storage Tank Pressure Gauge	Indicates the pressure in the inner tank.
RV-1	Storage Tank Inner Shell Relief Valve	Provides protection from excessive pressure in the storage tank.
SD-1	Storage Tank Inner Shell Rupture Disc	Provides an additional level of protection from excessive pressure in the storage tank.
LV-2	Transfer Tank Fill Line Shutoff Valve	Controls the gravity-fed flow of liquid oxygen from the storage tank to the transfer tank.
GV-3	Transfer Tank Vent Line Shutoff Valve	Controls the flow of oxygen gas vapors from the transfer tank to the vapor space of the storage tank.
P-2	Transfer Tank Pressure Gauge	Indicates the pressure in the transfer tank.
LG-2	Transfer Tank Liquid Level Gauge	Indicates the fluid level in the transfer tank. The gauge reads in percent full.
RV-2	Transfer Tank Inner Shell Relief Valve	Provides protection from excessive pressure in the transfer tank inner shell.
SD-3	Transfer Tank Inner Shell Rupture Disc	Provides an additional level of protection from excessive pressure in the storage tank.
C-3	Converter Vent Line Connector	Connector for attaching the converter vent line, allowing the converter to vent excess gas vapors back to the storage tank.
C-2	Filler Valve	Connects the transfer tank to the converter for LOX transfer.
CV-1	Converter Vent Line Check Valve	Keeps pressure from the storage tank from flowing back into the converter through the vent line.
F-1	Converter Full Indicator Gauge	A vapor pressure thermometer that monitors the converter vent line temperature. During the transfer of LOX to a converter, the thermometer indicates the warmer "GAS" temperature in the converter vent line. When the converter is full, the vent line fills with LOX, and the converter vent line temperature drops. The gauge indicator moves to the "LIQUID" position, indicating a full converter.
GV-4	Converter Vent Line Shutoff Valve	Controls the flow of oxygen gas vapors from the converter to the storage tank and prevents loss of storage tank gas when the converter is not being filled.
GV-5	Transfer Tank Pressure Buildup Valve	Controls the flow of LOX from the transfer tank to the pressure buildup coil. This valve is opened only when pressure is required to fill the converter.
SD-2	Outer Shell Relief Device	A rupture disc that provides an additional level of protection from excessive pressure in the outer shell.
CV-2	Converter Vapor Return Check Valve	Keeps pressure from the storage tank from flowing into the converter. (Code C and D carts only.)

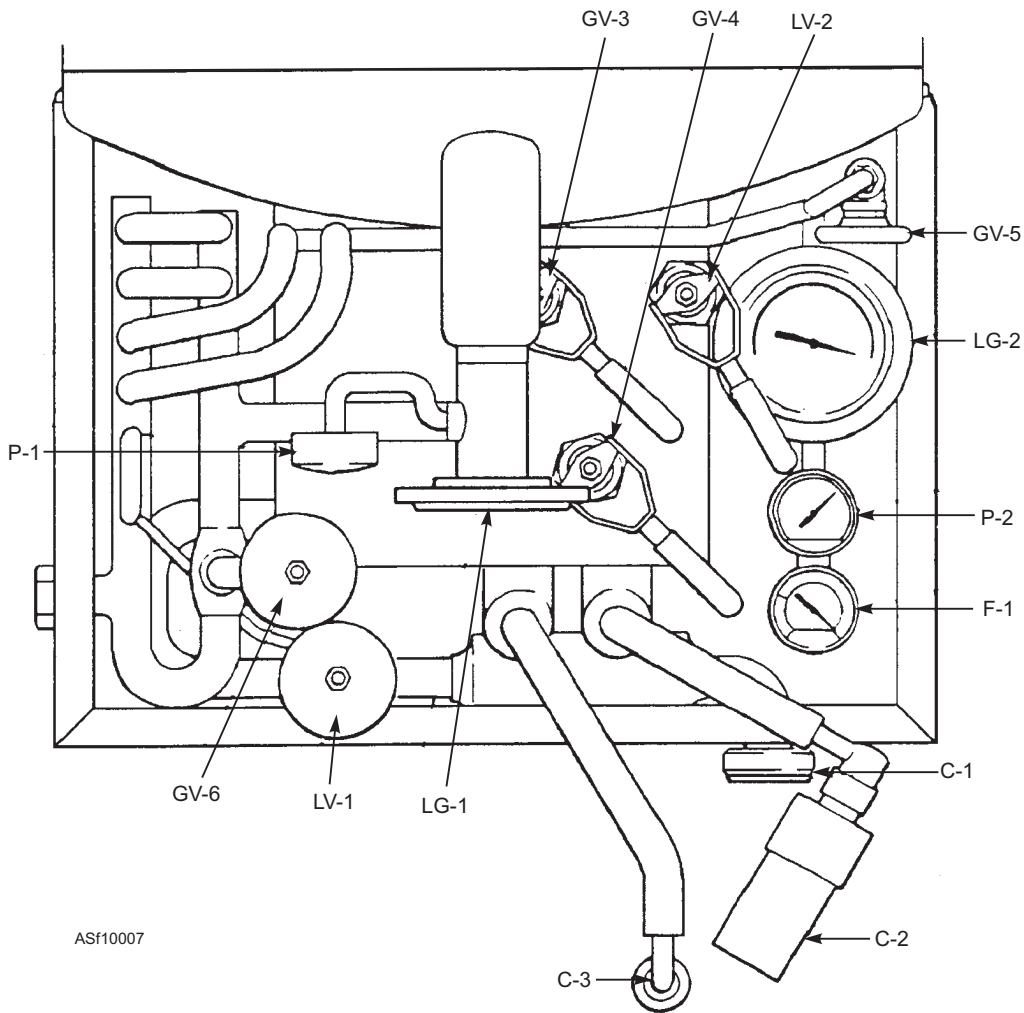

- | | | | |
|-------------|--|-------------|---|
| P-1 | Storage tank pressure gauge | P-2 | Transfer tank pressure gauge |
| LG-1 | Storage tank liquid level gauge | F-1 | Converter full indicator gauge |
| GV-4 | Converter vent line shutoff valve | LV-1 | Fill-drain line shutoff valve |
| GV-3 | Transfer tank vent line shutoff valve | CV-5 | Storage tank vent line shutoff valve |
| LV-2 | Transfer tank fil line shutoff valve | C-2 | Filler valve |
| GV-5 | Transfer tank pressure buildup valve | C-3 | Converter vent line connector |
| LG-2 | Transfer tank liquid level gauge | C-1 | Fill-drain line coupling |

Figure 10-7.—Physical layout of the LOX servicing trailer's controls and indicators.

Table 10-2.—System Pressures

	Working (operating) Pressure (psi)	Relief Valve Setting psi	Safety Device Burst Disc psi
Fill Line	Never More Than 50	75 ±10	
Storage Tank	50		58
Storage Tank Vent Line		50	
Transfer Tank Inner Shell		88-106	>106
Transfer Tank Vent Line		90	
Transfer Tank	90		120

During filling, LOX flow to the storage tank of the servicing trailer is through the fill-drain filter (LF-1) and the fill-drain shutoff valve (LV-1). (See fig. 10-7.) The fill-drain relief valve (RV-3) prevents excessive pressure if the fill-drain line shutoff valve (LV-1) and the service valve on the supply tank are closed with cold gas or liquid trapped within the supply line.

The fill-drain relief valve (RV-3) is connected to the vent line for safe discharge overboard. The storage tank vent line shutoff valve (GV-6) is left open during filling and normal storage, when it is safe to discharge vapors overboard. Use the storage tank liquid level gauge (LG-1) and the storage tank pressure gauge (P-1) to monitor storage tank conditions. If excessive pressure builds in the storage tank, the storage tank inner shell relief valve (RV-1) and the storage tank inner shell rupture disc (SD-1) vent excess gas and liquid.

The time required to fill the servicing trailer varies with each supply tank and supply line system. Under normal conditions of 30 psi transfer pressure, the storage tank should fill in 5 to 10 minutes. If it should take significantly longer to fill the tank, check for bad valves, a clogged filter, or a faulty transfer hose.

Transferring LOX to the Aircraft

Once filled with LOX, the servicing trailer is used to fill the aircraft's LOX converter. Use figure 10-6 to trace the flow of LOX from the storage tank to the transfer tank of the servicing trailer, and subsequently to the LOX converter on the aircraft.

In the servicing trailer, LOX flows from the storage tank to the transfer tank by gravity. It first passes through the transfer fill line shutoff valve (LV-2). During this process, the gaseous oxygen produced by cool down of the tank is vented back to the storage tank through the vent valve (GV-3). The transfer tank pressure gauge (P-2) and the transfer tank liquid level gauge (LG-2) can be used to monitor the condition of the transfer tank. When the transfer tank is filled to the desired level, as indicated by the liquid level gauge, valves LV-2 and GV-3 are closed.

To service an aircraft LOX converter, the converter is placed on the tray at the piping end of the storage tank, and both the vent line connector (C-3) and the filler valve (C-2) are connected to the converter. The filler valve is then opened to allow the pressures in the transfer tank and the aircraft's LOX converter to equalize. Then, the transfer tank pressure buildup coil is used to increase the pressure in the transfer tank to

approximately 90 psi. The transfer tank pressure buildup valve (GV-5) regulates pressure in the transfer tank. The goal is to maintain pressure in the transfer tank as high as possible, without exceeding 90 psi. LOX is now able to flow from the transfer tank into the converter because the pressure in the transfer tank is now greater than in the converter.

If the rate of pressure buildup in the transfer tank begins to look like it will exceed 90 psig, the transfer tank vent valve (GV-3) is opened to relieve excess pressure into the storage tank. This keeps the relief valve (RV-2) from opening and discharging gaseous oxygen from the vent line.

The converter full indicator gauge (F-1) will indicate when the aircraft's LOX converter is full. At that point, any overflow is automatically returned to the storage tank, bypassing through the converter vent line shutoff valve (GV-4).

Refer to figure 10-6 for the flow of LOX and gas in the system, and to figure 10-7 for the locations of the controls and indicators. The step-by-step procedures for transferring LOX to an aircraft converter are as follows:

NOTE: Before starting this procedure, be sure to don all of the appropriate safety clothing.

1. Ensure that all control valves are closed, except for the storage tank vent valve (GV-6).

LV-1: The fill-drain line shutoff valve

LV-2: The transfer tank fill line shutoff valve

GV-3: The transfer tank vent line shutoff valve

GV-4: The converter vent line shutoff valve

GV-5: The transfer tank pressure buildup valve

2. Ensure that the trailer is level, the caster is down and locked, and that the parking brake is set.

NOTE: Monitor the storage tank liquid level gauge (LG-1) and the storage tank pressure gauge (P-1) to ensure a sufficient LOX supply and a safe operating pressure.

3. Open the transfer tank fill line shutoff valve (LV-2) and the transfer tank vent line shutoff valve (GV-3), allowing LOX to flow into the transfer tank.

4. When the transfer tank liquid level gauge (LG-2) indicates that the transfer tank is full, close the transfer tank vent line shutoff valve (GV-3) and the transfer tank fill line shutoff valve (LV-2).

5. Connect the converter vent line (C-3) to the converter vent fitting.

6. Connect the AF filler valve (C-2) to the converter fill fitting:

- a. Position the filler valve against the purge fitting, and turn the housing clockwise, locking the filler valve in place.
- b. Push the knurled knob forward, and rotate it clockwise, locking the filler valve in the open position.

7. Open the transfer tank pressure buildup valve (GV-5) momentarily, and observe the transfer tank pressure gauge (P-2). When the transfer tank pressure rises to approximately 90 psig, close the transfer tank pressure buildup valve. It may be necessary to open and close the transfer tank pressure buildup valve repeatedly to maintain the desired pressure (90 psig) during converter servicing.

WARNING

The rate of pressure buildup in the transfer tank depends on the liquid level in the tank. On a full tank, the pressure will build very fast because of the small amount of vapor space to be filled. Use extreme caution in building the pressure in any case, and NEVER allow the pressure to exceed 90 psig.

8. Open the converter vent line shutoff valve (GV-4) to allow LOX vapor to return to the storage tank.

NOTE: Monitor the converter full indicator gauge (F-1). While the converter is filling, the gauge should indicate “GAS.” When the converter is full, the gauge should indicate “LIQUID.”

9. As soon as the converter full indicator gauge (F-1) indicates “LIQUID,” disconnect the filler valve (C-2).

10. Close the transfer tank pressure buildup valve (GV-5) and the converter vent line shutoff valve (CV-4). Then, disconnect the converter vent line connector (C-3).

11. If no other converters are to be serviced, empty the transfer tank.

- a. Open the transfer tank fill line shutoff valve (LV-2) and the transfer tank pressure buildup valve (GV-5). This will cause pressure to

build up in the transfer tank and transfer the remaining LOX back into the storage tank.

- b. Monitor the transfer tank liquid level gauge (LG-2). When the gauge indicates that the transfer tank is empty, close the transfer tank pressure buildup valve (GV-5) and the transfer tank fill line shutoff valve (LV-2).

12. Check that the only valve remaining open is the storage tank vent valve (GV-6).

Maintenance

Maintenance procedures for the TMU-70/M LOX servicing trailer can be found in *Servicing Trailer, Liquid Oxygen, Low Loss, Closed Loop, Type TMU-70/M*, NAVAIR 19-25D-26. The maintenance section in this manual is organized to address the three levels of maintenance responsibility: organizational, intermediate, and depot. The maintenance capability of the activity using or supporting the equipment will be the limiting factor as to the level of maintenance that can be performed on the equipment. If maintenance of the equipment is beyond the assigned maintenance responsibility of the activity, the next higher level of maintenance activity will perform the maintenance.

THE STORAGE TANK.—The storage tank of the LOX cart requires only corrosion control and cleaning at the O and I level. If you suspect the tank has lost its vacuum, then look for signs of frost build-up on the outside of the tank. If you suspect that the LOX loss rate is high, you will need to perform an evaporation loss rate test.

TOGGLE VALVES.—The TMU-70/M has three toggle valves that are susceptible to leaking. (See fig. 10-8.) If a toggle valve is leaking externally, you can detect the problem by conducting a bubble test (discussed later in this section). Fixing the problem may involve nothing more than tightening the valve or replacing the valve packing.

If a toggle valve is leaking internally, however, it won't show the type of symptoms found with a bubble test. Internal leaks show up as unexplained increases or decreases in liquid quantities or gas pressure. For example, you may note that the quantity gauge on the transfer tank continues to rise, even though the transfer tank fill line shutoff valve is closed. Internal leaking requires at least replacement of the seats. In some cases, replacement of the entire valve may be necessary.

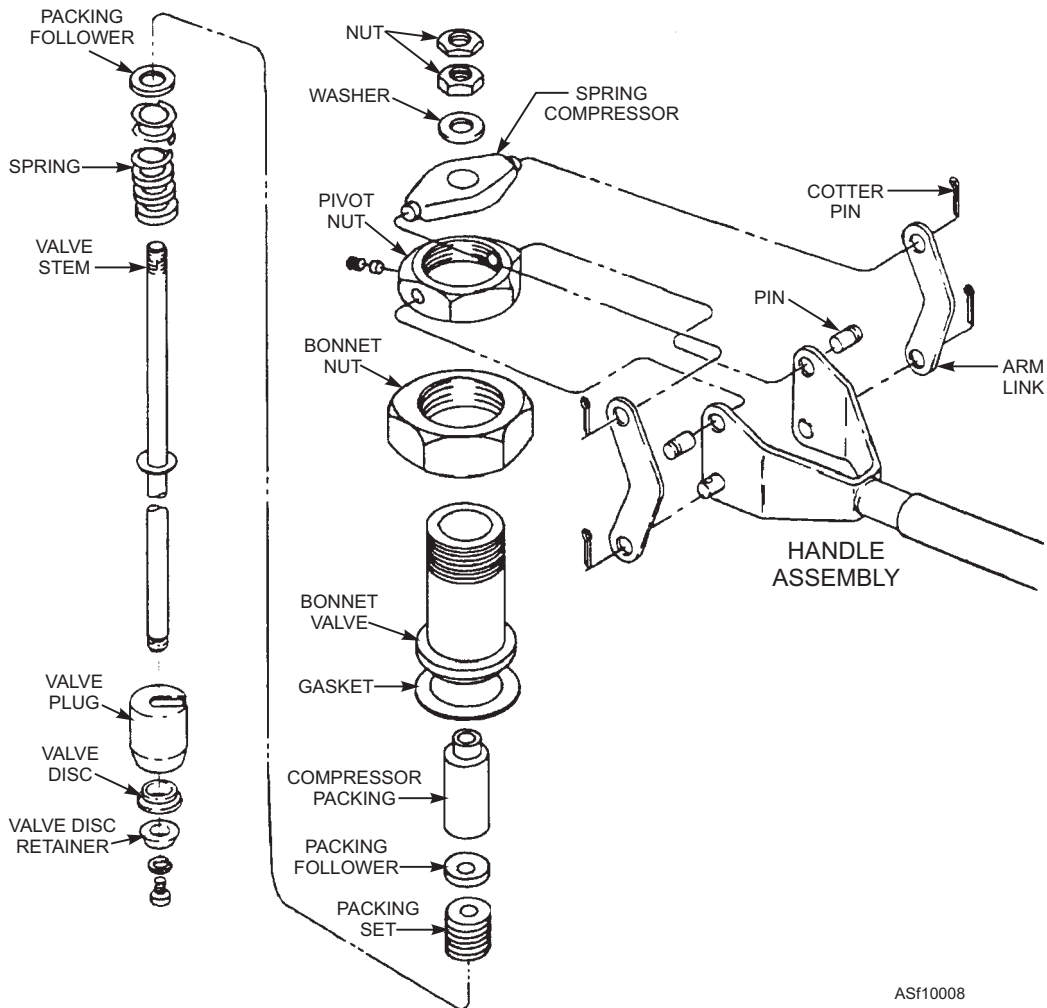

ASF10008

Figure 10-8.—Toggle valve assembly.

The three toggle valves in this system are the converter vent line shutoff valve (GV-4), the transfer tank vent line (GV-3), and the transfer tank fill line shutoff valve (LV-2). All three of the toggle valves function in the same way and have the same part number, although one transfers liquid and the other two are used for gaseous vent control.

WARNING

Before removing a toggle valve, make sure that there is no LOX in the unit and that the tank has warmed to ambient temperature.

All three valves are normally kept in the closed position. To open a valve, lift up on the handle. Then remove the toggle valve assembly from the tank assembly by removing the bonnet nut (shown in fig. 10-8).

When removing toggle valve 104235, lift it straight up and place your hand under the valve disc.

Then lift the valve disc away from the valve seat. Try to avoid tilting the valve on removal, as the stem may become disengaged from the valve plug.

Inspect the valve disc at the end of the stem, as it may only be necessary to replace that part. If, however, you have to replace the entire toggle valve assembly, remember that all parts must be cleaned to the standard required for use in oxygen systems, as specified in MIL-C-52211. Follow the current technical manual for your type of LOX cart.

After replacing a valve, check it for both internal and external leaking.

RELIEF VALVES AND RUPTURE DISCS.—Relief valves (RV) and rupture discs (SD), as shown in figure 10-9, are safety devices that protect the system from excessive internal pressure that could destroy the LOX cart tanks and plumbing system. More important, they also protect the operator and technician (you).

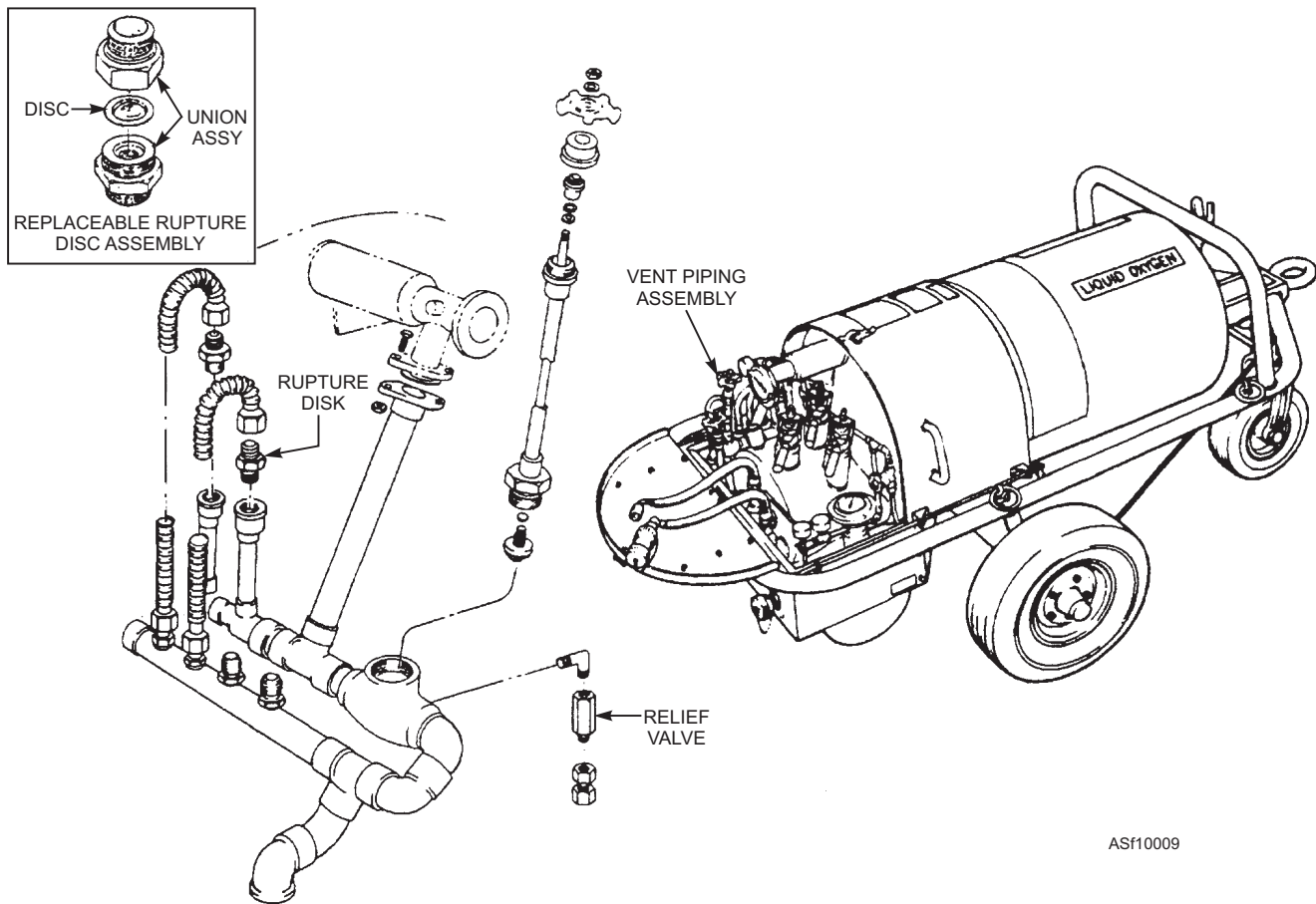

Figure 10-9.—Relief valve and rupture disc.

It is easy to detect a blown disc if you are around to hear it when it ruptures. If you are not there to hear it, you may still notice it on your preoperational check. Frost may form at the ruptured disc site, or you may see visible vapor. If, however, you have observed neither of the signs noted above, the condition will become apparent when you try to pressurize the LOX cart. You will be unable to bring the cart to operating pressure because of constant venting out of the ruptured disc or the faulty relief valve.

Replacing a Blown Rupture Disc.—Use the following steps for replacing a blown rupture disc:

NOTE: Before beginning the procedure, make sure you have a replacement on hand.

1. Ensure the storage and transfer tanks are empty and are at ambient temperature.
2. Connect a source of dry nitrogen gas to the storage tank fill coupling (C-1).
3. Open both the fill-drain valve (LV-1) and the storage tank vent valve (GV-6).
4. Sweep-purge the tank and piping by blowing nitrogen gas through the system.

5. Disconnect the flexible tubing from the exhaust side of the component to be removed, and then remove the component (relief valve or rupture disc). Tag the flexible line for easy reinstallation later.
6. Clean old anti-seize tape (MIL-T-27730) from all components to be reused.
7. Install fresh anti-seize tape on the replacement parts. Start the tape at the third thread from the end to prevent contamination inside the plumbing.
8. Visually inspect all parts for dents, corrosion, and damaged threads, and inspect the valve packing gland and seat for damage. If found to be unusable, replace with new parts.
9. Replace the rupture disc, and install new valve packing rings, where appropriate.

Replacing a Defective Relief Valve.—Defective relief valves cannot be adjusted or repaired; they are always replaced. Basically, you test a relief valve by raising the operating pressure high enough to see if the valve will open to bleed off excess pressure. When

Table 10-3.—The Storage Tank Relief Valve Test

Step	Action
	Ensure all control valves on the LOX cart are closed to start the test.
1	Open the transfer tank fill line shutoff valve (LV-2) and the transfer tank vent line shutoff valve (GV-3) to fill the transfer tank.
2	When the tank is full, close the transfer tank fill line shutoff valve (LV-2).
3	Slowly open the transfer tank pressure buildup valve (GV-5) to build pressure in the transfer and storage tanks.
	CAUTION: Monitor the storage tank pressure gauge (P-1) constantly while operating the transfer tank pressure buildup valve. Do not allow the supply tank pressure to go above 58 psig.
4	Raise the storage tank pressure slowly to 57 psig. The relief valve RV-1 should open somewhere between 45 and 55 psig. If RV-1 does not open, a faulty component is indicated and must be replaced.
5	After evaluating the storage tank relief valve, empty the transfer tank by opening the storage tank vent shutoff valve (GV-6), the transfer tank fill line shutoff valve (LV-2), and the transfer tank pressure buildup valve (GV-5).
6	When the transfer tank liquid level gauge (LG-2) indicates that the transfer tank is empty, close the transfer tank fill line shutoff valve (LV-2), and the transfer tank pressure buildup valve (GV-5). Leave the storage tank vent shutoff valve (GV-6) open.

enough pressure is bled off, the valve should reseal itself. Table 10-3 lists the steps in the procedure for testing the relief valve on the storage tank. Procedures for testing other relief valves are similar.

If a relief valve is faulty, the cart should be relieved of pressures and emptied of LOX prior to replacement of the valve.

After you disconnect the flexible tubing, unscrew and remove the relief valve. To purge the piping, connect a source of dry nitrogen gas (50 psig minimum) to the storage tank fill coupling. Turn on the nitrogen to blow out the line. After securing the nitrogen gas and removing it from the fill coupling, install the replacement valve and reconnect the flexible tubing.

NOTE: Use anti-seize tape on all pipe threads; start tape at the third thread to prevent contamination.

THE EVAPORATION LOSS RATE TEST.—Another important test is the evaporation loss rate test. (See table 10-4.) This test is used to determine if a LOX cart is experiencing an unacceptable rate of loss due to evaporation.

If the LOX cart fails the test, it is turned in for depot repair. The Aviation Support Equipment Technician performs NO repairs on the storage tank.

THE STORAGE TANK PIPING TEST.—When the storage tank piping is pressurized, you can use the storage tank piping test to check it for leaks. This test is often called a *bubble test*. (See table 10-5.)

When leaks are detected, repair, if possible, by tightening plumbing joints and/or valve packing.

CAUTION

Do not tighten joints or flanges while the tank is under pressure, while LOX is present in the piping, or while the temperature of components is below freezing (32°F/0°C).

Troubleshooting

Troubleshooting is a fine art. But, there are tools to assist you. Table 10-6 describes troubles, probable causes, checking procedures, and remedies for repairing LOX carts. Keep in mind that no LOX cart should be disassembled just to look for a problem. This is true because of the high state of cleanliness required, and the ever present risk of contamination. So, before removing components from a LOX cart, you must be as sure as possible that you know the cause of the

Table 10-4.—The Evaporation Loss Rate Test

Step	Action
	To start the test, ensure that the storage tank is filled to at least 50% capacity and that all valves are closed.
1	Open the storage tank vent line shutoff valve (GV-6).
2	Allow the storage tank to remain undisturbed for about 12 hours.
3	At the end of 12 hours, weigh the unit on a platform scale. Record the weight of the unit, the date, and the time.
4	Move the unit to a storage area, and position it on a level surface.
5	Allow the unit to remain undisturbed for a minimum of 24 hours.
6	Weigh the unit at the end of test period, and record the amount of loss.
7	Convert the weight loss to pounds per day (24 hours). The maximum weight loss should not exceed 17 pounds of LOX per day.
	HINT: The math is easier if you weigh the unit right at 24 hours.

Table 10-5.—The Storage Tank Piping Test

Step	Action
	To start the test, ensure the storage tank is filled to at least 50% capacity and all valves are closed.
1	Open the transfer tank fill line shutoff valve (LV-2) and the transfer tank vent line shutoff valve (GV-3) to fill the transfer tank.
2	When the transfer tank is full, close the transfer tank fill line shutoff valve (LV-2).
3	Slowly open the transfer tank pressure buildup valve (GV-5) to build pressure in the storage and transfer tanks.
4	When the storage tank pressure gauge (P-1) indicates 45 psig, close the transfer tank pressure buildup valve (GV-5).
	NOTE: You may have to manipulate the transfer tank pressure buildup valve (GV-5) to hold the storage tank pressure steady at 45 psig during the test.
5	Use a brush to apply Leak Test Compound at all plumbing joints, gauge flanges, and other areas where leaking is possible. Check the fill, pressure buildup, and vent valves for leakage.
6	After completing the test, empty the transfer tank by opening the storage tank vent shutoff valve (GV-6), the transfer tank fill line shutoff valve (LV-2), and the transfer tank pressure buildup valve (GV-5).
7	When the transfer tank liquid level gauge (LG-2) indicates that the transfer tank is empty, close the transfer tank fill line shutoff valve (LV-2), and the transfer tank pressure buildup valve (GV-5). Leave the storage tank vent shutoff valve (GV-6) open.

malfunction and that you can relate it to a system schematic. Your objective should be to expose the LOX cart to the risk of contamination for as short a time as possible.

NOTE: The troubleshooting charts presented in this training manual are only examples and are not necessarily complete. Before attempting repairs on any item of equipment, consult the applicable

Table 10-6.—Troubleshooting Chart

Trouble	Probable Cause	Checking Procedure	Remedy
Excessive frost or condensation on lines	Automatic opening of relief valve. Tank not level. Piping end down. Valves leaking. Vacuum deterioration.	Wait to see if condition is temporary Visual. Check for escaping gas. Check evaporation loss rate.	Abnormal condition will disappear. Level tank, or put piping end up. Repair or replace. Locate and repair leak, and re-evacuate tank.
Burst disc fails to blow above rated pressure	This is a dangerous condition. Lines are obstructed by foreign material or ice. Also, the applicable pressure relief valve has failed to operate. Wrong burst disc assembly.	Check lines for foreign material. Check setting of pressure relief valve. Compare with replacement disc assembly.	Reduce pressure by opening vent valve. Clear or thaw lines. Replace relief valve. Purge entire system. Replace with correct disc assembly.
Pressure relief valves do not open above rated pressure	Pressure gauge faulty or incorrectly calibrated. Valve faulty or incorrectly set. Valve frozen.	Check calibration. Build up tank pressure and recheck valve. Visual or manual.	Perform calibration procedures. If gauge cannot be calibrated, replace. Replace relief valve. Thaw valve.
Pressure relief valves open at less than rated pressure	Pressure gauge faulty or incorrectly calibrated. Relief valve faulty or incorrectly set.	Check calibration. Build up tank pressure and recheck valve.	Perform calibration procedures. If gauge cannot be calibrated, replace. Replace relief valve.
Excessive relief valve leaking below reseal pressure (36 psig for P/N 22385, 54 psig for P/N 22387, and 71 psig for P/N 22386 and 22386-1)	Ice in valve seat. Foreign material or object lodged in valve. Faulty relief valve.	Bubble check relief valve outlet. Bubble check relief valve outlet.	Warm valve to ambient temperature. Replace relief valve. Replace relief valve.

instruction manual. There you will find complete, up-to-date instructions for maintaining the equipment.

Safety Precautions

Hazards to personnel handling liquid oxygen are due primarily to its extremely cold temperature. LOX can freeze and seriously damage skin tissue on contact. The effect is similar to frostbite or thermal burns. Use great caution when filling warm containers, because vigorous boiling, splashing, and evaporation (rapid expansion) will occur.

The following safety precautions must be followed by all personnel working with liquid oxygen.

- Keep work areas and equipment free of oil, grease, or any other combustible material.
- Avoid spilling LOX on floor or deck areas. In case of accidental spillage, thoroughly ventilate the area.
- Immediately extinguish any fire near equipment containing LOX. Use normal fire-fighting methods. Any flow of oxygen must be stopped by closing valves, if possible. Use a strong stream of water to divert free-flowing LOX away from combustibles.
- Place a clean drip pan (made of stainless steel, aluminum, or copper) under outlet (overflow) vents of servicing units, samplers, etc. You take this precaution to prevent the contact of spilled LOX with oil, grease, or other material that may be in the surrounding area.
- When transferring LOX, do not leave valves open all the way. You should initially open valves wide, and then immediately close them about one-quarter turn. Otherwise, the valves may freeze in the open position.
- Disconnect filling or transfer lines as soon as the transfer process is completed.
- Do not leave LOX in a closed container or trapped in a line between two valves. Always open a valve at one end to prevent the buildup of excessive pressure.
- Do not introduce moisture into a LOX system. When connecting or disconnecting the filler valve nozzle, ensure that it is free of moisture.
- Purge piping and equipment with dry, oil-free nitrogen, Type I, Grade A, Fed. Spec BB-N-411.

“DO NOT USE OXYGEN TO PURGE OXYGEN SYSTEMS.”

- To aid in preventing leaks or material failure, do not over torque liquid oxygen system tubing and fittings. Pay close attention to torque values.

Protective Clothing

Because of the hazards involved, you must wear the following protective clothing when working with LOX:

- **A face shield or safety goggles.** Always wear eye protection when working with LOX. Safety glasses with side shields are acceptable.
- **Gloves.** Always wear gloves when handling any equipment that is, or may have been, in recent contact with LOX. Leather welder’s gloves should be loose fitting so that they can be quickly removed if LOX should get into them. Always wear protective gloves when handling purging units as well.
- **Coveralls.** Always wear protective clothing (coveralls, explosive ordinance handlers, cotton sateen, fire resistant, MIL-C-14610). Wear cuffless sleeves and trouser legs over the tops of gloves and shoes.
- **Aprons.** Always wear an apron made of impermeable cotton duck coated with rubber. Tie the apron in a such a way that it will be easy to remove in case of an emergency.
- **Shoes.** Always wear special LOX boots (shoes, safety, molders, congress style, black, MIL-S-82245). This boot is designed to be easily removed in an emergency.

Clothing that is splashed by LOX must be removed immediately and thoroughly aired for at least 1 hour.

The requirements for protective clothing are outlined in *Aviation Crew Systems Oxygen Equipment*, NAVAIR 13-1-6.4.

LOX CONTAMINATION

LOX generating plants that produce oxygen for the Navy must meet high standards of purity in their product. Oxygen supplied to the Navy must contain a minimum of 99.5% pure oxygen. Initial purity standards are set very high to compensate for the small amount of contamination that may occur during handling, transfer, and storage.

Because LOX is stored at its boiling point, it is constantly evaporating. Evaporation has the effect of concentrating the less volatile impurities present in the LOX. This gradual process of increasing contamination is accelerated if significant additional contaminants are introduced during handling and transfer operations. As noted above, “procurement standards” of purity are set slightly higher than “use standards” to provide a small margin of safety. This margin of safety, however, does not provide a margin for error. Never relax your vigilance in quality control against the ever present sources of increasing contamination in LOX.

Contaminants

Hydrocarbons are contaminants that are present in the air we breathe, which is the major source of oxygen used in the production of LOX. As a result, hydrocarbons are always present in LOX, but in small amounts. Our goal is to keep the amount of hydrocarbons that come in contact with LOX as small as possible. The following is a list of some of the materials that react violently with oxygen under the right conditions of temperature and pressure:

oil	grease	benzen
tar	cotton	illuminating gas
lamp black	coal dust	paint
asphalt	gasoline	sulfur
kerosene	JPfuel	hydrogen
propane	butane	acetylene
naphtha	alcohol	sugar
ether	aniline	cloth and wood

If exposed to liquid oxygen, organic materials, such as those listed above (including dirt soaked with oil or grease), will burn violently when ignited. For that matter, all combustibles are potential explosion hazards when mixed with liquid oxygen. The mere mixture of LOX with powdered organic materials under certain conditions may cause an explosion. If the vapor from LOX mixes with fuel vapor in the right proportions, the mixture will explode if ignited; therefore, every fire involving LOX must be regarded as an explosion hazard.

Hydrocarbon fumes may also be added by the compressors and other equipment of the generating plant. The presence of hydrocarbons in LOX

constitutes a potential fire and explosion hazard if either the flammability or solubility limit of the hydrocarbon is exceeded. Some of the more important hydrocarbons are discussed in the following text.

ACETYLENE.—Acetylene, a colorless gas, is the most hazardous hydrocarbon contaminant because it is highly insoluble in LOX (does not dissolve). Acetylene also solidifies at extremely low concentrations. Once in its solid state, acetylene can be readily triggered into ignition. And since it is chemically unstable, acetylene can decompose and become its own source of ignition. The presence of acetylene in LOX has been the cause of several major explosions at LOX generating plants.

INERT SOLID CONSTITUENTS.—Inert solids are classified as “inert” because they do not react with oxygen to create a fire or explosion hazard. They are also classified as inert to distinguish them from other hydrocarbons that become solids when their solubility limits are exceeded. Inert solids in LOX are hazardous for a number of reasons. First, they may cause mechanical malfunctions or failures. Second, inert solids can cause filters, lines, injectors, and valves to plug. Third, inert solids may accumulate charges of static electricity, and thus become sources of ignition. Inert solids consist of three distinct forms: moisture, carbon dioxide, and particulate matter.

Moisture.—Water vapor condenses to ice on contact with LOX, and is always present in the form of atmospheric moisture. Like other substances that solidify in LOX, ice can cause filters, lines, injectors, and valves to plug.

Carbon Dioxide.—Carbon dioxide is slightly soluble in LOX, but at high concentrations it generally exists as a solid.

Particulate Matter.—Particulate matter consists of rust, metal fragments, dust, and fibers derived from the equipment or the environment of the LOX supply system. These contaminants are solids at normal temperatures as well as at LOX temperatures.

In addition to the hydrocarbons there are other constituents, which if present in LOX, may also affect the mental and physical well-being of aircrews.

NITROUS OXIDE.—Nitrous oxide may present such hazards as those listed above, as well as the inherent danger of chemical mixture with acetylene when both exceed their saturation limits. The mixture

of nitrous oxide and acetylene may concentrate at the bottom of tanks, and it can detonate.

REFRIGERANTS.—Compounds present in the form of refrigerants (Freon) may indicate leaks present in the generating plant during manufacturing of the LOX. In such cases, manufacturing equipment must be repaired to eliminate the sources of contamination. Such compounds may also be a residue of equipment cleaning operations.

SOLVENTS.—Solvents present in LOX may be a cleaning residue, or may have been introduced into the oxygen system at the intake air stream of the generating plant.

Detection of Contamination

Liquid oxygen contamination is detected by means of an odor test, and by conducting sampling analysis. Odor testing is a simple, but reliable, test conducted by you, the AS, and sampling analysis is a more precise test done in a laboratory.

ODOR TESTING.—An odor test should be performed on LOX trailers under each of the following conditions:

- After filling the storage tank
- After maintenance actions affecting the liquid system
- When the tank has been left empty without positive pressure
- Whenever contamination is suspected

Aircraft LOX systems also require an odor test as soon as possible after an aircraft accident/incident, or following a report of in-flight odors by the pilots or aircrew.

An odor test is performed as follows:

1. Cover the bottom of a 400-milliliter beaker (or a similar container) with clean, dry, filter paper or other absorbent paper.
2. Pour approximately 200 milliliters of the suspect LOX into the beaker.
3. Partially cover the top of the beaker with a watch-glass cover. (This will prevent atmospheric constituents from being absorbed by the exposed liquid as it evaporates.)
4. Place the beaker in an area free from air currents and extraneous odors, and allow the LOX to

evaporate and the beaker to warm up to room temperature.

5. When the liquid has completely evaporated, remove the watch-glass and smell the beaker contents at frequent intervals until the accumulated frost on the outside of the beaker has completely melted.

Odors will be most noticeable when the beaker has warmed to nearly room temperature. If odors are present, purge the LOX container or system in accordance with existing directives. You, as the AS, will be responsible for LOX washing your cart.

SAMPLE ANALYSIS.—After an aircraft accident/incident, a LOX sample must be sent to a test site for analysis. Include details of the incident, including the history of the supply source of the LOX, which should be traceable back to your LOX cart.

Purging of Contaminants

Purging is the cleansing of impurities from oxygen systems and containers. There are two ways to purge oxygen containers, LOX washing and hot nitrogen purging.

LOX WASHING.—The LOX wash method is used on large containers, such as storage tanks and LOX trailers. In LOX washing, you lower the contamination to acceptable levels by replacing the contaminated LOX with LOX known to be uncontaminated. But before LOX washing, the containers must be prepared, and the preparation is different for a warm container than for a cold one.

Warm Containers.—To prepare a warm container for LOX washing, first pressurize the container to 30 to 40 psig with unheated, dry nitrogen gas (conforming to Federal Specification BB-N-411). Then, vent the container. After repeating this procedure three times, you can perform the LOX wash.

Cold Containers.—To prepare a cold container for LOX washing, first dump residual LOX from the container by using the build-up coil for expulsion. DO NOT open the vent during the dump procedure. When the container is empty of residual LOX, you can proceed to the LOX wash.

The LOX Washing Procedure.—Partially fill the container with LOX that is known to be uncontaminated and that meets the concentration limits for storage containers. (See MIL-O-27210.)

With the vent valve closed, use the pressure build-up coil to pressurize the container to 30 to 40 psig, and then dump the LOX. Repeat this procedure for a total of three cycles.

Collecting a Sample for Testing.—With the vent valve still closed, partially fill the container with enough LOX to permit a sample of the liquid to be withdrawn for analysis. The sample will be sent to a designated ABO test site, which may or may not be on board your station. Results are returned within 1 working day of submission.

Samples are collected in the cryogenic sampler, shown in figure 10-10. Use and maintenance of the sampler are covered in-depth in *Cryogenic Sampler, Model FCS 2001, AG-115SL-OMP-000*.

If testing indicates that the LOX sample is acceptable, the container may be filled and put into service. If testing indicates an unacceptable level of

contamination, the container must be drained and the LOX wash test repeated.

PURGING.—When repeated LOX washing fails to decontaminate a LOX trailer, the trailer is shipped to a depot-level activity that has the proper equipment to perform a hot nitrogen purge.

Purging of aircraft converters is done locally. Part of your job as an AS is to maintain the equipment that “O” level activities use to purge aircraft converters with hot nitrogen. This text covers the Aiel Corporation’s aircraft liquid oxygen system gas purging set (fig. 10-11).

This LOX purging set is designed to use gaseous nitrogen or gaseous oxygen for purging (oxygen is used only when nitrogen is not available). In the set, the gas is super heated by an electric heater to $225^{\circ}\text{F} \pm 25^{\circ}$ for the purging process. The hot gas is forced through the contaminated unit, where it mixes with the contamination and is vented to the atmosphere.

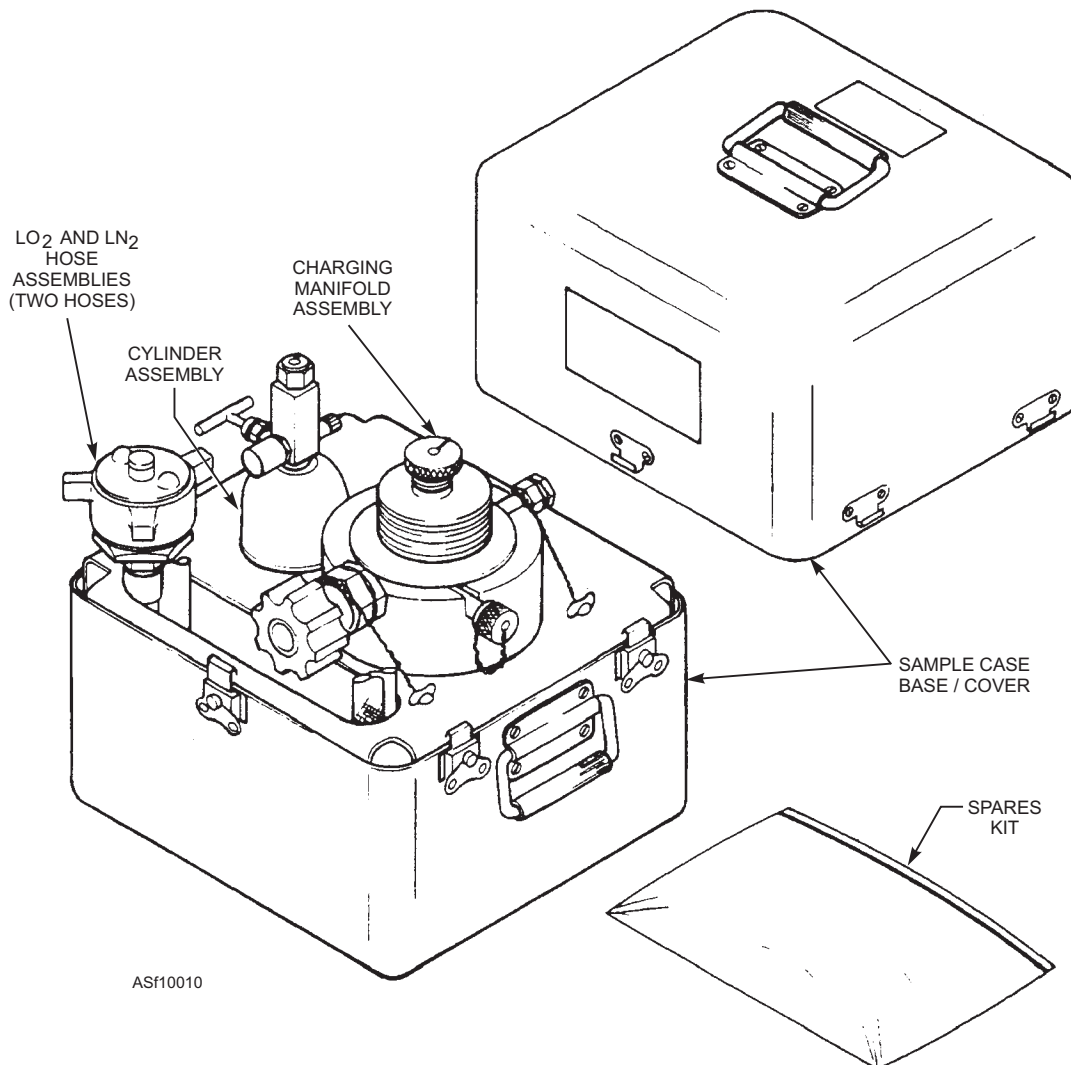
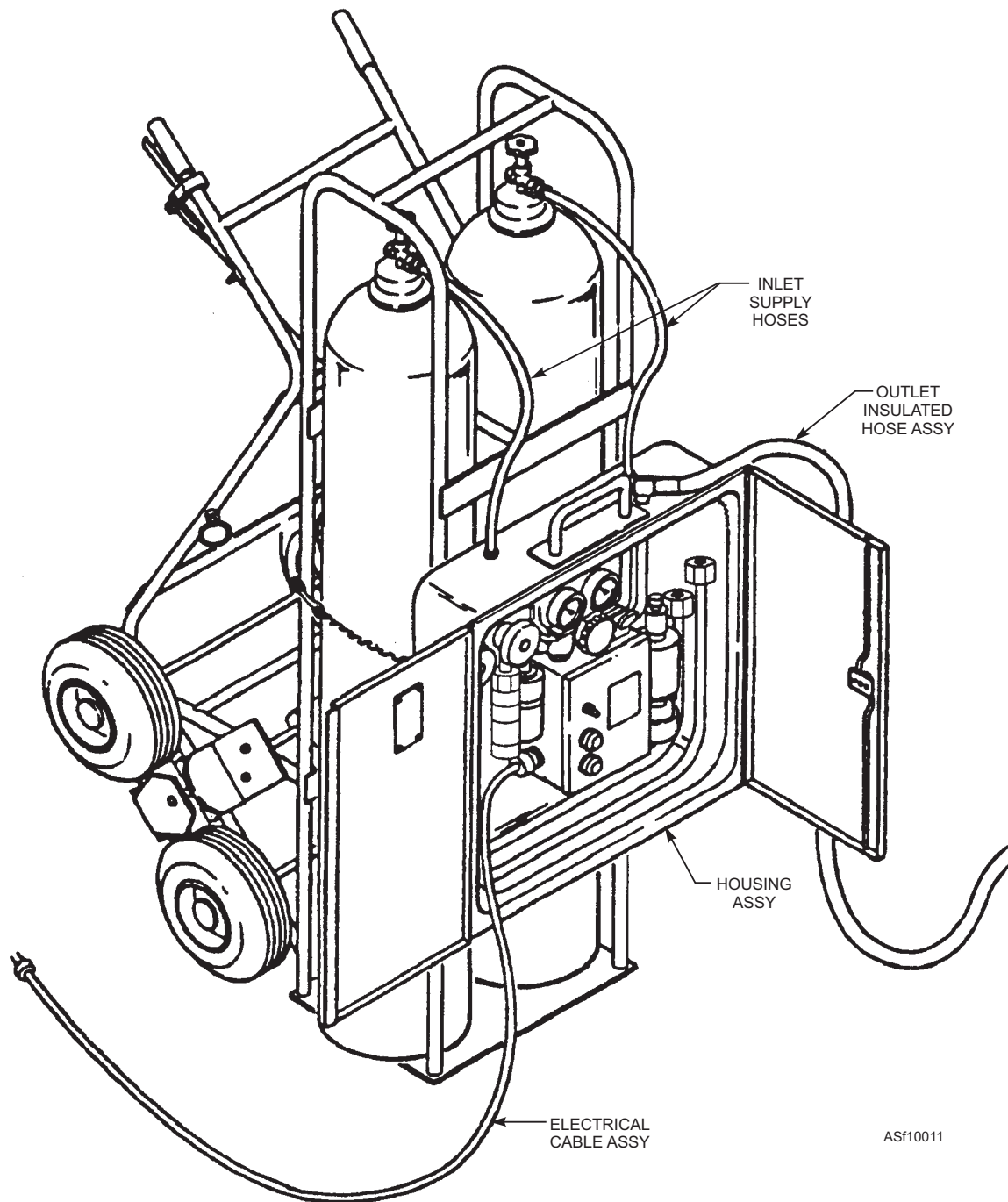

Figure 10-10.—FCS 2001 cryogenic sampler.



AS10011

Figure 10-11.—Aircraft liquid oxygen system gas purging set.

The LOX purging set consists of truck and housing assemblies, with the housing assembly containing the controls and valves. Located within the housing assembly is an electrical enclosure that contains a heater block assembly, switches, indicator lamps, and a circuit breaker. When not in use, the supply and delivery lines, fittings, filler valve, electrical adapter (for conversion to 400 Hz power), and the electrical power connecting cord are stowed within the housing assembly. The housing assembly may be removed

from the hand truck for use as a bench-mounted installation in the oxygen converter repair shop.

In-depth maintenance procedures for the LOX system gas purging set are outlined in NAVAIR 19-25D-27.

Standards of Cleanliness

All maintenance procedures involving components in liquid or vacuum systems must be performed in a clean, well-ventilated area. To reduce

the risk of contamination, do not leave systems open any longer than necessary. Always take steps to protect open systems against possible contamination. Use clean polyethylene bags, sheet material, and polyethylene pressure-sensitive tape to wrap and seal disassembled or exposed parts, subassemblies, and assemblies. If possible, store disassembled items in a clean room until they are required for assembly.

Prior to opening a LOX system, inspect the exterior for the presence of hydrocarbons. Use ultraviolet light to check parts, couplings, vent lines, converter and storage tank fill lines, and surrounding areas for the presence of hydrocarbons prior to opening the liquid oxygen or vacuum system.

Wear clean, white, lint-free gloves while working on a oxygen system. Clean, tag, and bag any removed parts that will be reused. Limit disassembly to the level that is necessary for repair or replacement only. Do not remove a component solely for the purpose of cleaning and inspecting it.

Q10-3. Gaseous oxygen becomes a liquid when it is cooled below what temperature?

1. -183°F
2. -200°C
3. -242°C
4. -297°F

Q10-4. When warmed to ambient temperatures (about 70°), LOX expands to what ratio of its liquid volume?

1. 10 to 1
2. 150 to 1
3. 862 to 1
4. 1200 to 1

Q10-5. How is the tank of a liquid oxygen storage tank constructed?

1. It is a single wall tank insulated with Styrofoam
2. It is a double-wall tank with a powder-type material used as an insulator
3. It is a double-wall tank with helium gas used as an insulator
4. It is a single-wall tank with no insulator

Q10-6. What is the storage capacity of the TMU-70/M LOX cart?

1. 10 gal
2. 20 gal
3. 35 gal
4. 50 gal

Q10-7. LOX is moved from the storage tank to the transfer tank of the TMU-27/M by what means?

1. By gravity
2. By a pump
3. By gas pressure in the storage tank
4. By a vacuum in the transfer tank

Q10-8. The two types of safety devices on a LOX cart are relief valves and rupture discs?

1. True
2. False

Q10-9. Which of the following tests is used to determine if a LOX cart is experiencing an unacceptable rate of loss?

1. A storage tank piping test
2. A vent line flow test
3. An evaporation loss rate test
4. A transfer tank vent line test

Q10-10. Which of the following terms is often used to describe the storage tank piping test?

1. The bubble test
2. The leak test
3. The sweat test
4. The hiss test

Q10-11. LOX used by the Navy must contain a minimum of how much pure oxygen?

1. 95%
2. 99%
3. 99.5%
4. 99.9%

Q10-12. Which of the following contaminants is the most hazardous hydrocarbon that can be found in LOX?

1. Hydrogen
2. Acetylene
3. Helium
4. Carbon monoxide

Q10-13. Which of the following is NOT a condition under which you would perform an odor test on a LOX cart?

1. After filling the storage tank
2. Upon completion of preoperational inspections
3. When the tank has been left empty without positive pressure
4. Whenever contamination is suspected

Q10-14. Which of the following activities can perform a hot nitrogen purge on a LOX cart?

1. *An organizational-level activity*
2. *An intermediate-level activity*
3. *A depot-level activity*
4. *A Navy contracted activity*

GASEOUS OXYGEN

LEARNING OBJECTIVES: Identify the components of gaseous oxygen cart systems. Identify procedures for inspecting, checking, cleaning, testing, and adjusting gaseous oxygen cart system components. Identify procedures for troubleshooting gaseous oxygen cart systems. Identify procedures for repairing, removing, and replacing gaseous oxygen cart system components.

There are two types of gaseous oxygen used in the Navy: aviators' breathing oxygen (99.5% pure) and technical (or industrial) oxygen. Technical oxygen may have a small moisture content that can freeze at high altitudes, so it isn't suitable for breathing aboard aircraft. Gaseous oxygen is colorless, odorless, and tasteless.

GAS CYLINDERS

Gas cylinders are made of high quality steel. Cylinders for high-pressure gases, such as oxygen and nitrogen, are seamless. Cylinders used for low-pressure gases, such as acetylene, may be welded or brazed. All cylinders are carefully tested at pressures above the maximum permissible charging pressure.

Safety Devices

All gas cylinders have safety devices in their valves, in their shoulders, in the bottoms of the cylinders, or in a combination of these places. One type of safety device is the fusible plug, which may be described as a threaded hex head bolt with a center filled with a fusible metal. If the cylinder is subjected to high temperatures, the fusible metal will melt, allowing the gas to vent to the atmosphere.

Safety caps with rupture discs are used in the valves of cylinders that contain nitrogen and oxygen. These caps have a frangible disc supported by fusible metal (contained in the safety cap), which blocks off

escape ports. If a cylinder becomes heated above the melting point of the fusible metal, the pressure in the cylinder will increase and the frangible disc will rupture, venting the gas to the atmosphere. To protect the valves of gas cylinders, threaded valve protection caps screw onto the cylinder neck ring.

Identifying Markings

Gas cylinders used by the Navy, Army, and Air Force carry standard identifying features, in addition to markings required by the Interstate Commerce Commission. In the past, many injuries occurred and a great deal of damage was caused by mistaking one gas cylinder for another. To remedy this situation, a national program was started to make it almost impossible to mistake one type of cylinder from another. Under this program, the identifying features used by the Armed Forces consist of color coding the cylinders, stenciling the name of the gas along two sides of the cylinders, and affixing decals to the shoulders of cylinders.

The official color codes for marking compressed gas cylinders is given in the current MIL-STD-101. Aviators' breathing oxygen cylinders are green with one white band. Technical oxygen cylinders are solid green with no bands.

WARNING

Do not rely solely on color codes for identifying the contents of gas cylinders. Exact identification of the contents of a cylinder can only be made from the name stenciled on the cylinder and from the affixed decals.

Navy-owned gas cylinders are further identified by indented serial numbers, preceded and followed by letters in the following pattern:

U U
SX618793S
N N

Navy serial numbers are also augmented by a designated letter preceding the numerals. This letter identifies the cylinder in respect to the specific gas contained within. In the above example, the letter X identifies the cylinder as one that contains oxygen.

GASEOUS OXYGEN SERVICING TRAILERS

Gaseous oxygen servicing trailers are used to replenish aircraft oxygen storage cylinders and emergency bailout systems. They provide mobile sources of oxygen that can be towed or manually moved to the aircraft. Different models of gaseous oxygen servicing trailers are currently in use in the Navy. The most prevalent one you will encounter is the A/U26U-1 oxygen servicing unit. The general appearance of the A/U26U-1 is shown in figure 10-12.

The servicing system of the A/U26U-1 is mounted on a three-wheeled, pneumatic tire trailer with a drawbar. The drawbar lunette eye is used to attach the

unit to a towing vehicle. A retractable swivel caster supports the drawbar when the unit is not attached to a towing vehicle. The trailer is equipped with a hand-operated, mechanical parking brake.

Components

The components of the A/U26U-1 servicing system are divided into four primary subsystems: a gas storage system, a nitrogen module, an oxygen module, and servicing/interface equipment. The primary components of each subsystem are discussed in the following paragraphs. In the discussion that follows, refer to figure 10-13, which is a flow schematic of the servicing unit.

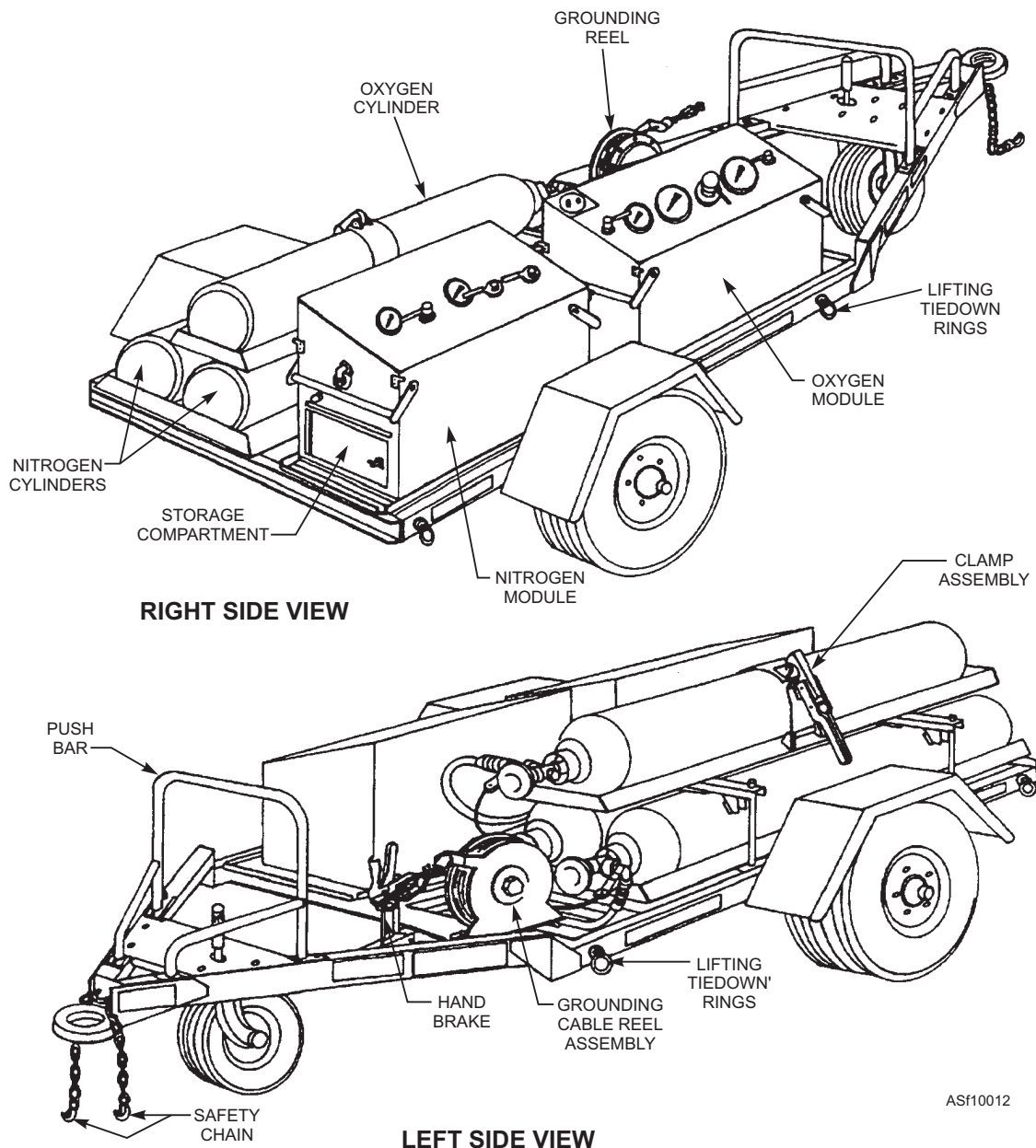
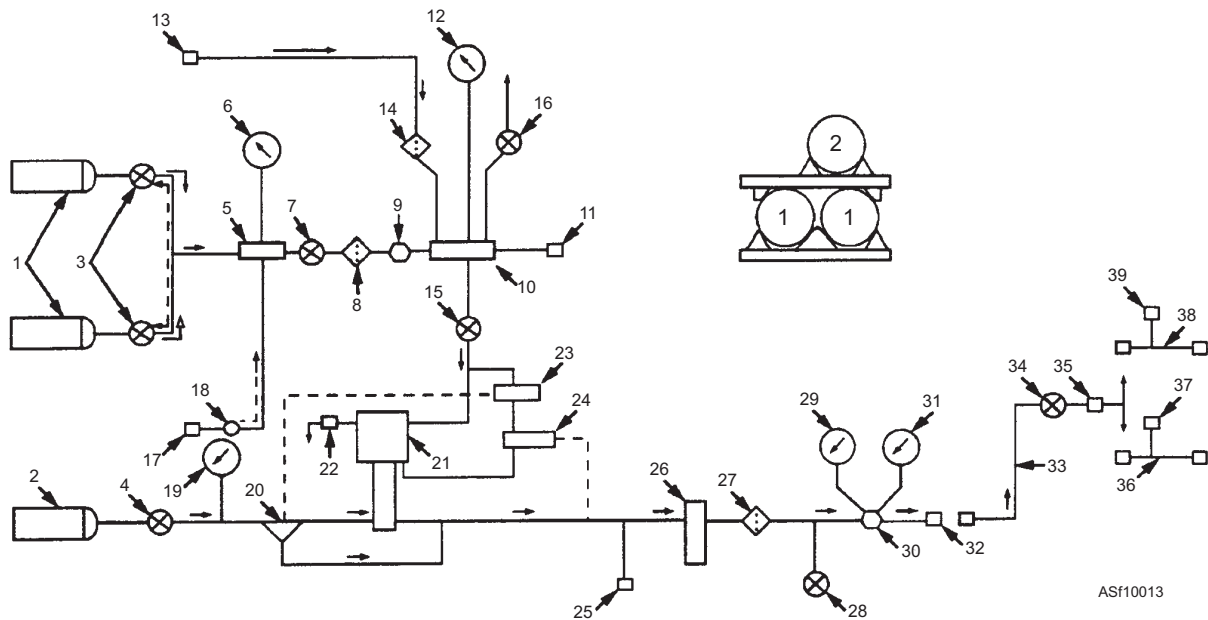

Figure 10-12.—A/U26U-1 oxygen servicing unit.



- | | |
|-------------------------------------|--|
| 1. Nitrogen cylinders (2 each) | 21. Boost pump |
| 2. Oxygen cylinder | 22. Exhaust (muffler) |
| 3. Nitrogen cylinder valves | 23. Pilot valve (normally closed) |
| 4. Oxygen cylinder valve | 24. Pilot valve (normally open) |
| 5. High pressure manifold | 25. Relief valve |
| 6. Nitrogen supply pressure gauge | 26. Purifier |
| 7. Nitrogen supply valve | 27. Filter |
| 8. Preset regulator filter | 28. Oxygen vent valve |
| 9. Preset regulator | 29. Regulator inlet pressure gauge |
| 10. Low pressure manifold | 30. Oxygen regulator |
| 11. Low pressure rupture disc | 31. Regulator outlet pressure gauge |
| 12. Boost pump drive pressure gauge | 32. Oxygen service connection |
| 13. Ship/shop air connection | 33. Servicing hose |
| 14. Inlet air filter | 34. Servicing valve |
| 15. Boost pump drive valve | 35. Servicing adapter connection |
| 16. Boost pump drive vent | 36. Low pressure servicing adapter |
| 17. Nitrogen recharge connection | 37. Low pressure adapter rupture disc |
| 18. Recharge check valve | 38. High pressure servicing adapter |
| 19. Oxygen supply pressure gauge | 39. High pressure adapter rupture disc |
| 20. Selector valve | |

Figure 10-13.—Air/nitrogen boost pump drive and oxygen servicing flow schematic.

NOTE: A number or numbers within parentheses, such as (1), will appear following a component name throughout the discussion on the oxygen servicing unit. This number, or numbers, will always refer to figure 10-13, although other figures will also be referenced.

GAS STORAGE SYSTEM.—The gas storage system stores the oxygen and nitrogen used in the operation of the unit. It consists of one oxygen cylinder and nitrogen cylinders. (See figure 10-14.)

NOTE: The number in parentheses following a component name refers to figure 10-13.

Nitrogen Cylinders.—As shown in figure 10-14, the nitrogen cylinders (1) are mounted on the trailer assembly in a rack. They are held in place by crossbar retainers located at the front and rear of the trailer. Each cylinder is equipped with a valve (3) to shutoff nitrogen flow from the cylinder when the unit is not in operation. The cylinders are interconnected via hoses and a high-pressure manifold (5) and grounded to the trailer frame. Each cylinder contains 340 standard cubic feet of Type 1 (gaseous), Class 1 (oil-free) nitrogen at a pressure of 3,500 psi when fully charged. The nitrogen within the cylinders is used to drive an oxygen boost pump when compressed air drive is not available.

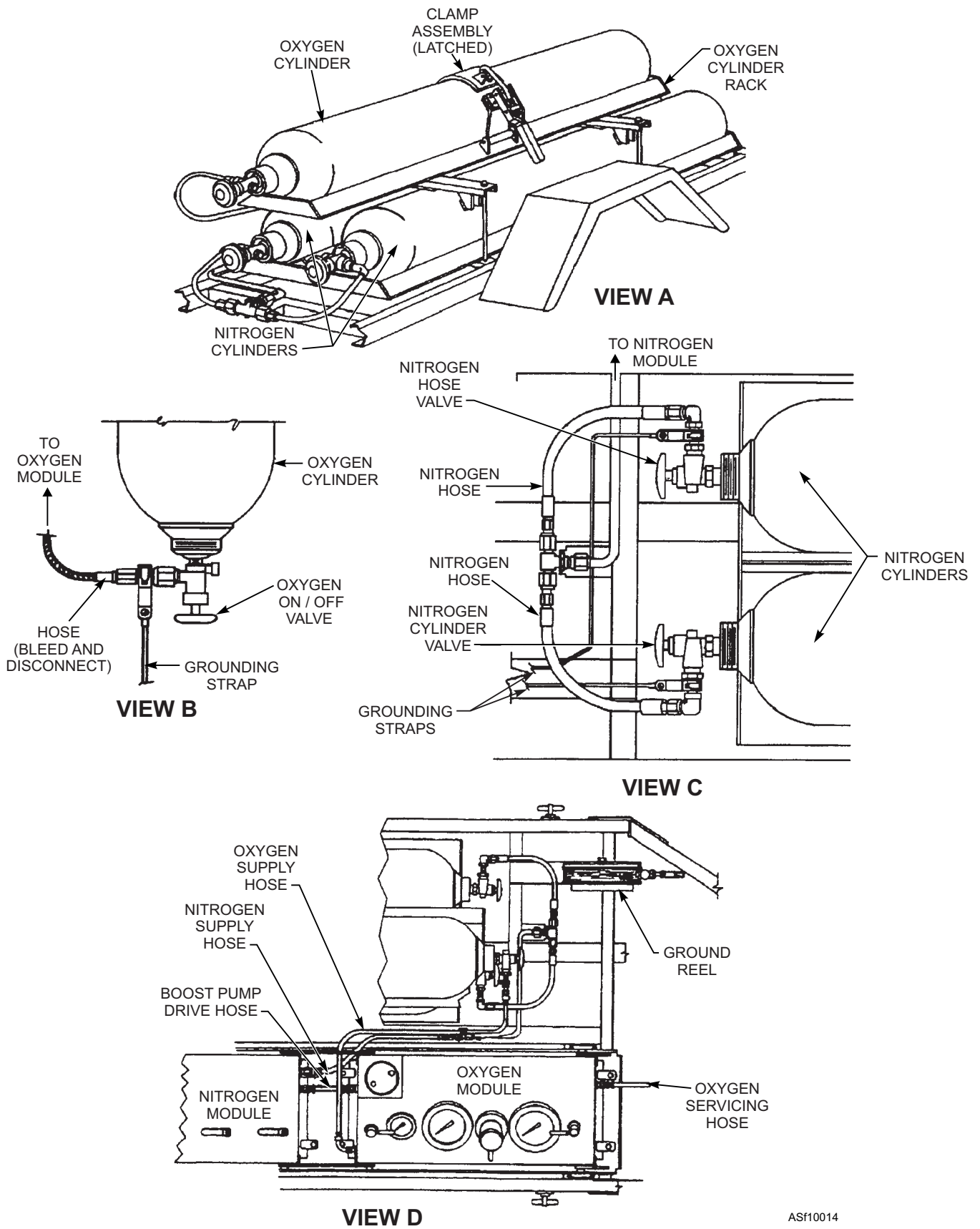

ASF10014

Figure 10-14.—A/U26U-1 gas storage system.

NOTE: The number in parentheses following a component name refers to figure 10-13.

Oxygen Cylinder.—As shown in figure 10-14, the oxygen cylinder (2) is mounted in its own rack on top of the nitrogen cylinders and held in place by a clamp assembly. The cylinder is equipped with a shutoff valve (4) that controls the flow of oxygen to and from the oxygen module. The cylinder is grounded to the trailer frame by a grounding strap. It contains 300 standard cubic feet of gaseous oxygen at a pressure of 2,400 psi when fully charged.

NOTE: The oxygen and nitrogen modules are designed so that they can be easily removed from the servicing unit for use inside an oxygen shop. When used in this manner, an external source of compressed air and oxygen must be provided in the oxygen shop.

NITROGEN MODULE.—The nitrogen module, figure 10-15, supplies unregulated compressed air (90 to 150 psi) or regulated gaseous nitrogen to the oxygen module to drive the oxygen boost pump. Compressed air is the primary drive source for the boost pump. Gaseous nitrogen should only be used as a drive source for the boost pump when compressed air is not available. The following components are contained on or within the nitrogen module. (Refer to figure 10-15 to locate the components on the module, and to figure 10-13 to trace air/nitrogen flow.)

High Pressure Manifold.—The high-pressure manifold (5) provides a collecting point for the nitrogen gas after it leaves the cylinders (1), and it directs the gas to the nitrogen supply pressure gauge (6) and nitrogen supply valve (7). It is mounted underneath the top panel of the nitrogen module. (See figure 10-15, rear view.)

Nitrogen Supply Pressure Gauge.—The nitrogen supply pressure gauge (6) indicates the nitrogen pressure in the cylinders. It is located on the left corner of the nitrogen module panel. (See figure 10-15, front view.)

Nitrogen Supply Valve.—The nitrogen supply valve (7) is a lever-operated, two-way ball valve that controls the flow of the high-pressure nitrogen from the cylinders (1) through the filter (8) and preset regulator (9) to the low-pressure manifold (10). It is located on the top left corner of the nitrogen module panel. (See figure 10-15, front view.)

Preset Regulator Filter.—The preset regulator filter (8) is a 10-micron, replaceable element type that removes moisture and foreign matter from the nitrogen

before it enters the preset regulator. (See figure 10-15, rear view.)

Preset Regulator.—Located inside the nitrogen module rear cover, the preset regulator (9) reduces the pressure of the nitrogen coming from the cylinders and regulates the pressure at the oxygen boost pump inlet to 120 to 130 psi. (See figure 10-15, rear view.)

Low-pressure Manifold.—The low-pressure manifold (10) collects the compressed air from the ship/shop, or the low-pressure nitrogen from the preset regulator, and directs it to the boost pump drive pressure gauge (12), the boost pump drive valve (15), and the boost pump vent valve (16). (See figure 10-15, rear view.)

Low-pressure Rupture Disc.—The low-pressure burst disc (11) protects the pump in the event of excessive pressure. It prevents boost pump drive pressure from exceeding 240 psi. (See figure 10-15, rear view.)

Boost Pump Drive Pressure Gauge.—The boost pump drive pressure gauge (12) indicates the air or nitrogen pressure delivered to the oxygen boost pump. It is located on the nitrogen module panel to the right of the nitrogen supply valve. (See figure 10-15, front view.)

Ship/Shop Air Inlet Connection.—The ship/shop air inlet connection (13) provides a means of connecting an external compressed air source to the servicing unit for driving the boost pump. The air inlet connection is located on the left side of the nitrogen module (See figure 10-15, left side view.)

Shop/Ship Air Inlet Filter.—The inlet air filter (14) is a 10-micron, replaceable element filter (14) that removes moisture and foreign matter from the air before it enters the boost pump. (See figure 10-15, rear view.)

Boost Pump Drive Valve.—The boost pump drive valve (15) provides a positive means of controlling the air or nitrogen going to the boost pump (21). It is a two-position valve located to the right of the boost pump drive pressure gauge on the nitrogen module panel. (See figure 10-15, front view.)

Boost Pump Drive Pressure Vent.—The boost pump drive pressure vent (16) provides a means of venting boost pump drive pressure and nitrogen module gas line pressure. It is a two-position valve located on the upper right corner of the nitrogen module panel. (See figure 10-15, front view.)

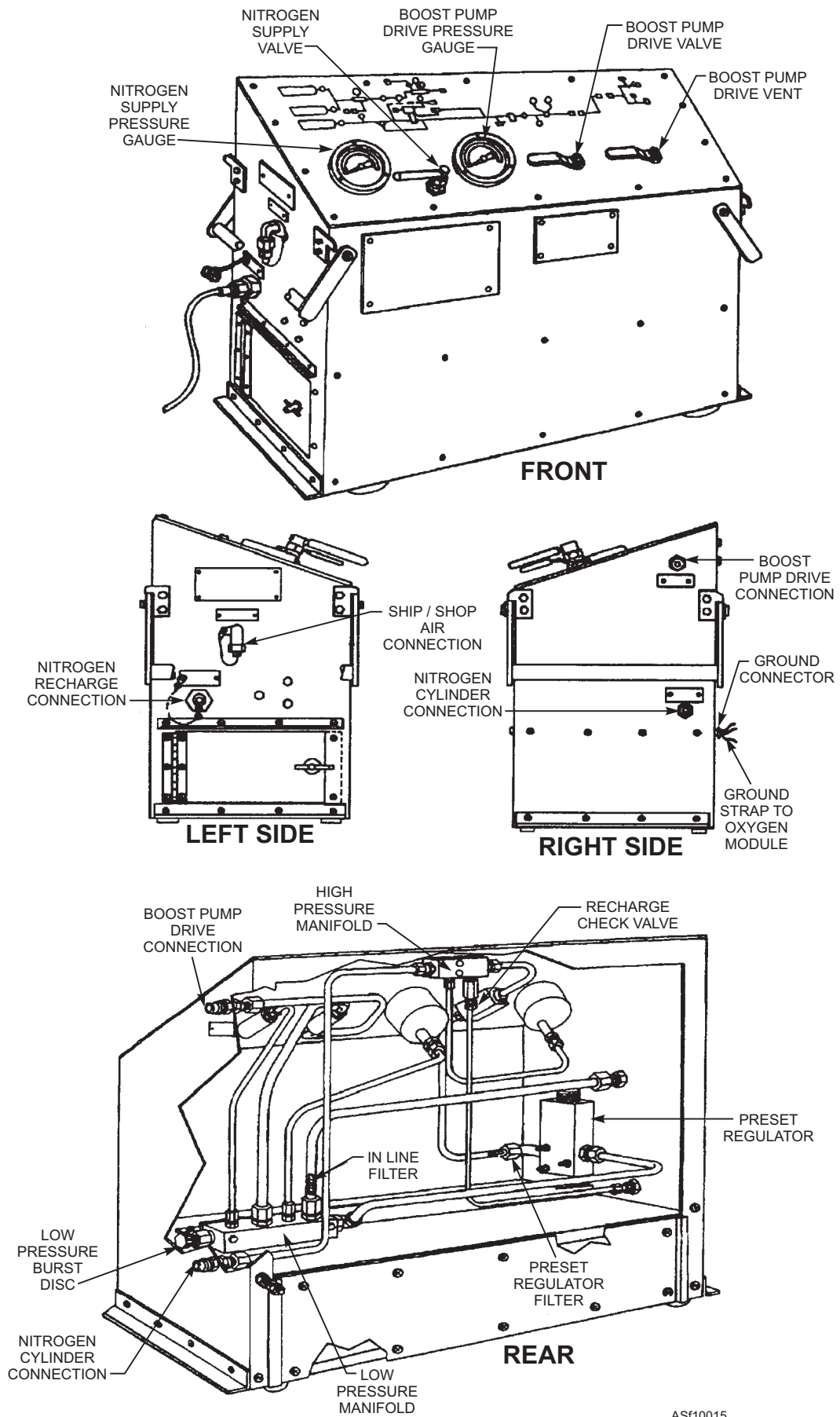

ASf10015

Figure 10-15.—Nitrogen module.

Nitrogen Recharge Connection.—The nitrogen recharge connection (17) provides a means of refilling both nitrogen cylinders while they are still on the servicing unit. (See figure 10-15, left side view.)

Nitrogen Recharge Check Valve.—The nitrogen recharge check valve (18) prevents the reverse flow of nitrogen from the system during recharging, and it

prevents cylinder pressure from escaping when the cylinder valves are open. It is screwed into the high-pressure manifold underneath the nitrogen module panel. (See figure 10-15, rear view.)

OXYGEN MODULE.—The oxygen module, figure 10-16, transfers the oxygen from the gas storage system by equalizing pressure or by boosting oxygen

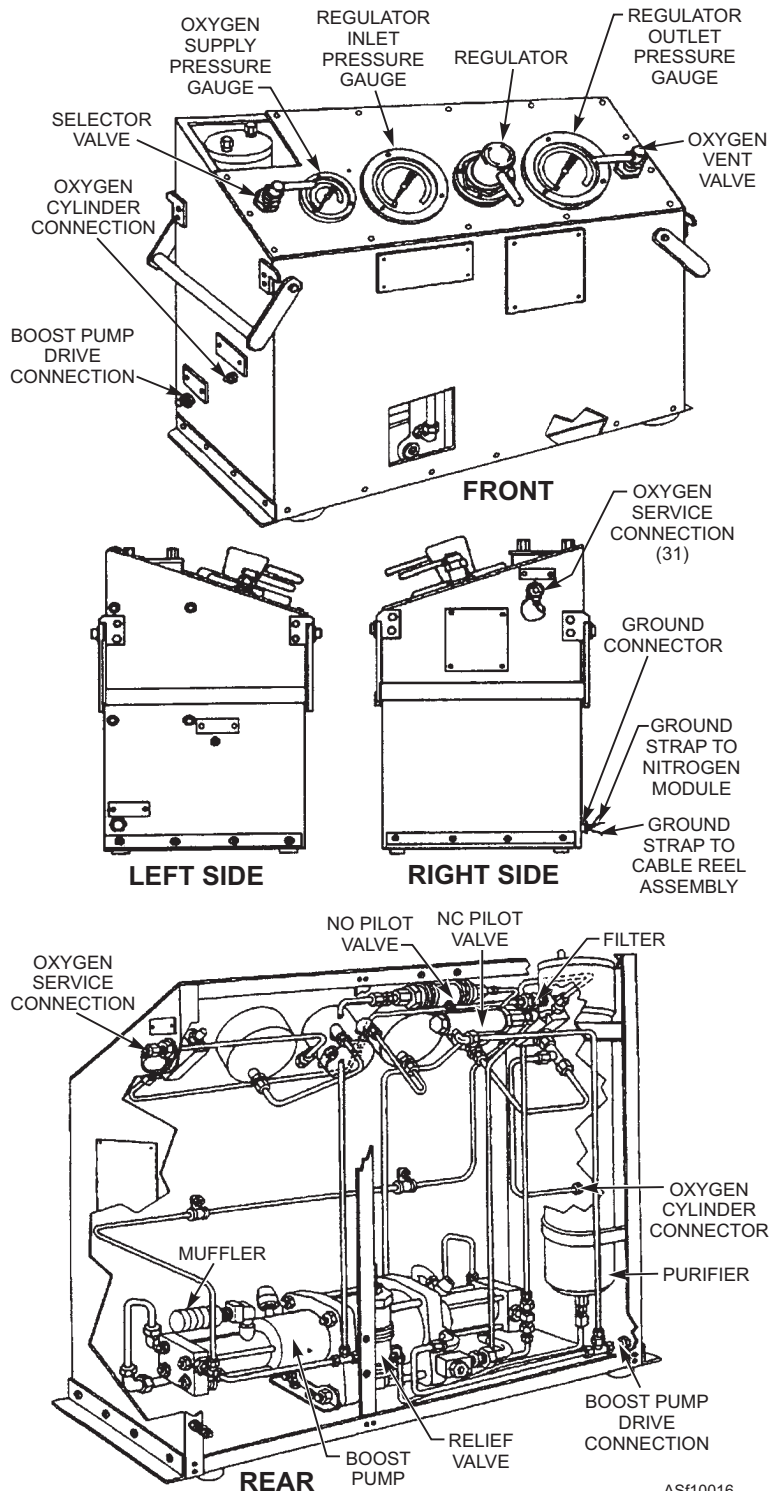

Figure 10-16.—Oxygen module.

AS110016

cylinder pressure with the boost pump. During aircraft oxygen servicing, the oxygen module is grounded to the nitrogen module and trailer grounding reel. The following components are contained on or within the oxygen module (refer to figure 10-16 to locate the components on the module, and to figure 10-13 to trace oxygen flow):

NOTE: The number in parentheses following a component name refers to figure 10-13.

Oxygen Supply Pressure Gauge.—The oxygen supply pressure gauge (19) indicates the amount of pressure in the oxygen cylinder (2). The gauge is located on the left corner of the oxygen module panel. (See figure 10-16, front view.) The oxygen cylinder valve (4) must be open to read cylinder pressure.

Selector Valve.—The selector valve (20) is a three-position (OFF/BOOST/BYPASS), hand-operated valve that controls oxygen flow to the boost pump (21), or it allows the oxygen to bypass the boost pump. It also provides a means of shutting off the oxygen supply to the servicing system. The selector valve is located on the left side of the oxygen module panel. (See figure 10-16, front view.)

Boost Pump.—The boost pump (21) increases (boosts) the pressure of the gas leaving the oxygen cylinder for high-pressure servicing operations. It has a compression ratio of 25:1 to 36:1, depending on oxygen cylinder pressure. The boost pump consists of

a large area reciprocating air drive piston directly coupled by a connecting rod to a small area gas piston. The gas piston operates in a high-pressure gas barrel section. Each gas barrel end cap contains high-pressure inlet and outlet check valves. (The boost pump serves the same purpose as the pump and motor assembly on the nitrogen servicing unit covered in chapter 9. The internal design and operation of the oxygen boost pump are quite similar to those of the nitrogen servicing unit's pump and motor assembly.) Figure 10-17 shows various features of the boost pump. The boost pump is physically located inside the oxygen module. (See figure 10-16, rear view.)

NOTE: The number in parentheses following a component name refers to figure 10-13.

Pilot Valves.—Two boost pump pressure-operated pilot valves (23) and (24), are located within the oxygen module. (See figure 10-16, rear view.) The pressure operated pilot valve (23) is a normally closed (NC) oxygen module safety device, which prevents the boost pump (21) from operating with a high compression ratio (in excess of 25:1). When the gaseous oxygen supply to the boost pump (21) inlet port falls below 200 psi, the pilot valve (23) closes, shutting off the boost pump drive (nitrogen or compressed air). The pilot valve (23) opens when the oxygen supply pressure to the boost pump (20) exceeds 300 psi.

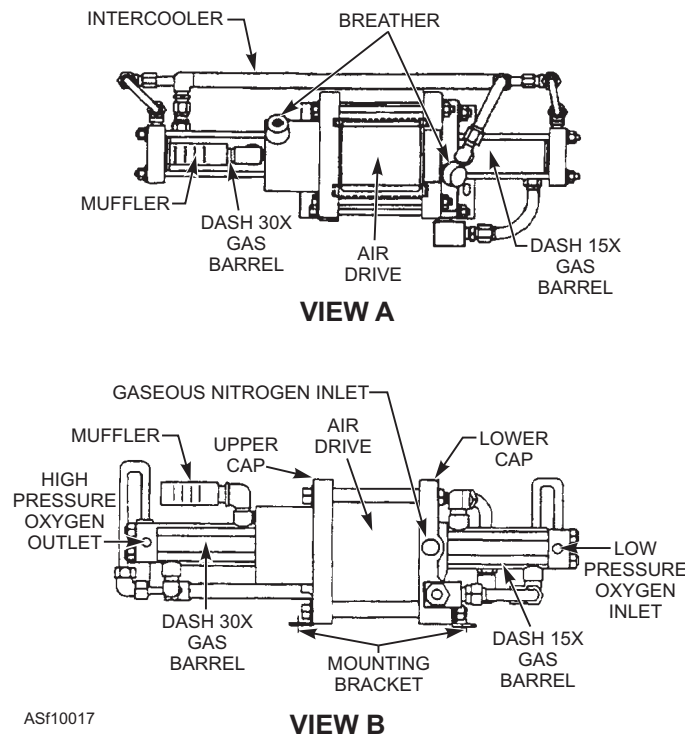

Figure 10-17.—Oxygen boost pump.

The pressure operated shutoff pilot valve (24) is a normally open (NO) oxygen module safety device, which limits the boost pump (21) maximum output pressure. When the pressure of oxygen discharged from the boost pump (21) exceeds 2,400 psi, the pilot valve (24) closes and shuts off the pump gaseous nitrogen or compressed air drive. The pilot valve (24) opens when oxygen pressure discharged from pump falls below 1,900 psi. This pilot valve (24) also provides semiautomatic on/off control of the pump. During pump operation, if the oxygen discharge line is closed by the servicing valve (34) and the discharge oxygen pressure exceeds 2,400 psi, the pilot valve (24) shuts off the pump (21). Opening the servicing valve (34) reduces the pump (21) gaseous oxygen discharge to less than 1,900 psi, and the pump (21) starts operating.

Relief Valve.—The relief valve (25) vents excess pressure if the boost pump (21) outlet pressure exceeds 2,900 psi. It is located inside the oxygen module. (See figure 10-16, rear view.)

WARNING

Do not use a nitrogen servicing unit desiccant cartridge on an oxygen servicing unit. While they look the same, they are not interchangeable. Ensure that the cartridge used on the oxygen servicing unit is specifically designed for oxygen use.

Purifier.—The purifier (26), located inside the oxygen module (figure 10-16, rear view), removes moisture and other contaminant from the oxygen entering the servicing line. The purifier assembly is identical in appearance to the purifier used on the nitrogen servicing unit; however, it is not interchangeable. Always use only the item (part number) specified in the maintenance manual.

NOTE: The number in parentheses following a component name refers to figure 10-13.

Filter.—The filter (27) traps foreign matter not removed by the purifier. It is a 10-micron, replaceable element filter located underneath the panel of the oxygen module. (See figure 10-16, rear view.)

Oxygen Vent Valve.—The oxygen vent valve (28) provides a means of venting gas pressure upstream of the regulator (30). It is a two-position (OFF/VENT) valve located on the upper right corner of the oxygen module control panel. (See figure 10-16, front view.)

NOTE: The number in parentheses following a component name refers to figure 10-13.

Regulator Inlet Pressure Gauge.—The regulator inlet pressure gauge (29) displays the pressure at the inlet side of the oxygen regulator. It is located to the right of the oxygen supply pressure gauge on the oxygen module control panel. (See figure 10-16, front view.)

Pressure Regulator.—The pressure regulator (30) controls the pressure of the gas delivered to the servicing line. It is located to the right of the regulator inlet pressure gauge on the oxygen module control panel. (See figure 10-16, front view.)

Regulator Outlet Pressure Gauge.—The regulator outlet pressure gauge (31) displays the pressure at the outlet side of the oxygen regulator. It is located to the right of the pressure regulator on the oxygen module control panel. (See figure 10-16, front view.)

Oxygen Service Connection.—Located on the right side of the oxygen module, the oxygen service connection (32) provides a means of attaching a servicing hose to the servicing unit. (See figure 10-16, right side view.)

SERVICING AND INTERFACE EQUIPMENT.—The servicing and interface equipment consist of those parts required to connect the oxygen servicing unit to the aircraft oxygen storage system and includes the grounding cable reel assembly. The interface equipment consists of connecting hoses between the oxygen/nitrogen modules that convey air or nitrogen to drive the oxygen boost pump. The servicing and interface equipment include the following items: (See figure 10-18.)

NOTE: The number in parentheses following a component name refers to figure 10-13.

Servicing Hose.—The servicing hose (33) transfers the oxygen from oxygen servicing unit to the aircraft system being serviced.

Servicing Hose Valve.—The servicing hose valve (34) controls the flow of oxygen from the servicing hose to the system being charged.

Servicing Adapters.—To prevent over pressurizing aircraft oxygen storage systems, servicing adapters are attached to the servicing hose valve (34). The low-pressure adapter (36), which is used when servicing low-pressure systems, contains a

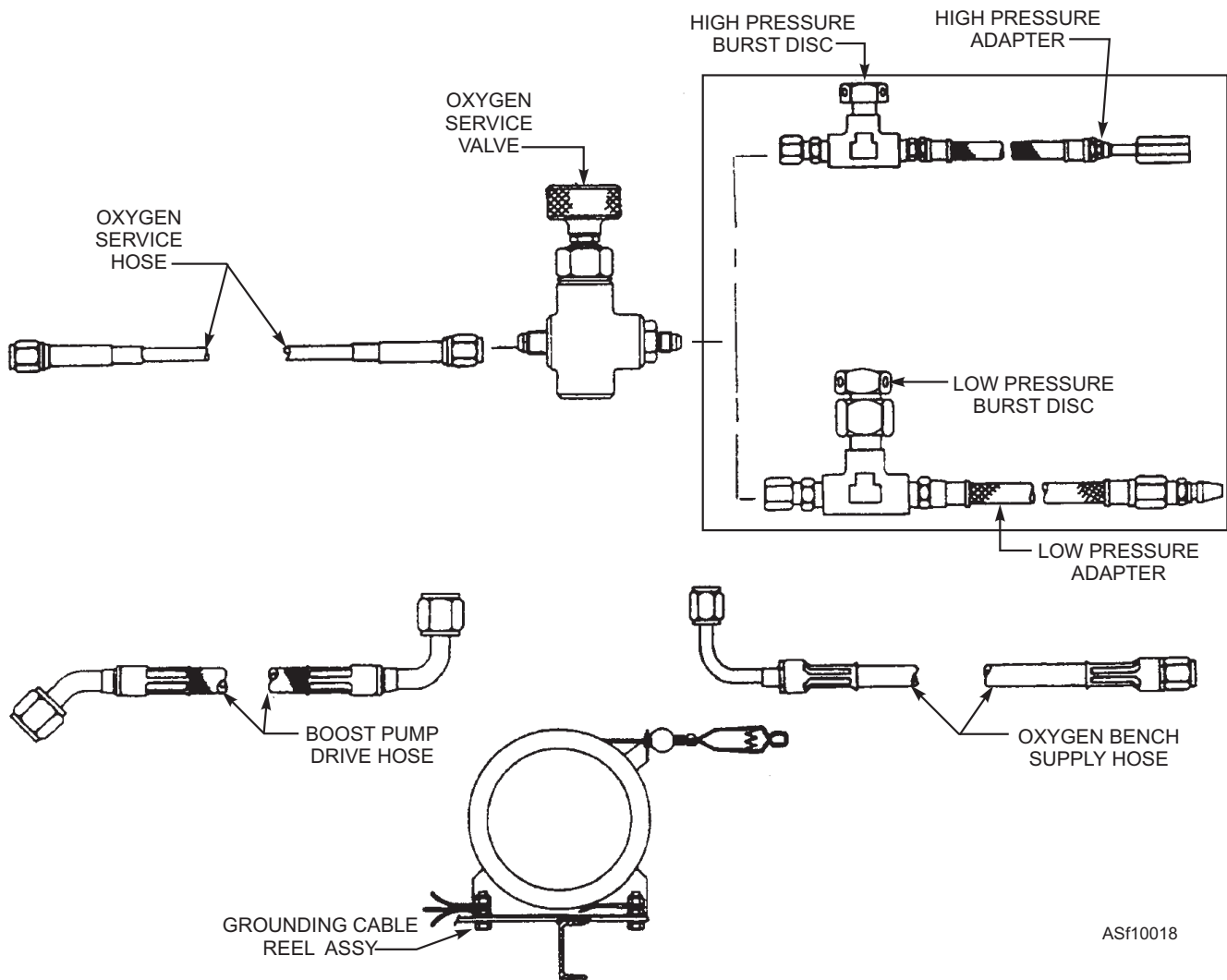

ASF10018

Figure 10-18.—Oxygen/nitrogen servicing/interface equipment.

burst disc (37) that will rupture when oxygen outlet pressure exceeds 600 psi. The high-pressure adapter (38), used when servicing high-pressure systems, contains a burst disc (39) that will rupture when oxygen outlet pressure exceeds 2,400 psi.

Boost Pump Drive Hose.—The boost pump drive hose interconnects the oxygen and nitrogen modules to carry drive air or nitrogen from the nitrogen module to the oxygen module boost pump. (See figure 10-14, view D.)

Oxygen Bench Supply Hose.—The oxygen bench supply hose is used to connect an external oxygen source to the oxygen module.

Grounding Cable Reel Assembly.—The grounding cable reel assembly provides a means of connecting the servicing unit to the aircraft being serviced (grounding) to prevent sparks from static electricity.

WARNING

Oil, grease, and other readily oxidizing material is dangerous in the presence of oxygen. When handling any parts of oxygen equipment, your hands must be clean and free of such substances. This also applies to any tools used. Neglect of these precautions may result in explosion or fire.

Operation

The operating procedures discussed are general in nature. For exact operating procedures for the A/U26U-1, consult NAVAIR 19-25D-31, *Operation and Intermediate Maintenance Instructions with Illustrated Parts Breakdown, Oxygen Servicing Unit, A/U26U-1*. As operation of the unit is discussed, refer to figure 10-19 for a view of the servicing unit's operating controls, and to figure 10-13 to trace gas flow.

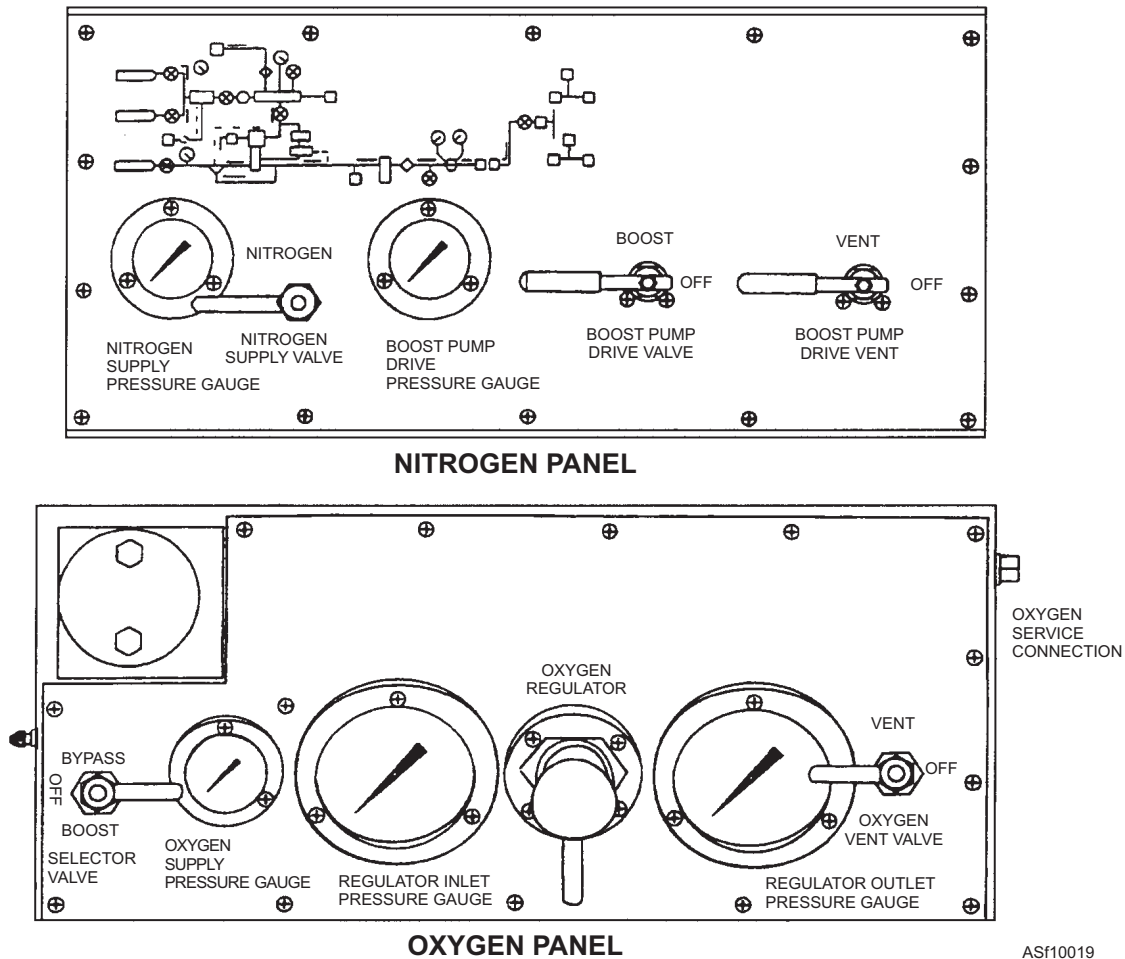

Figure 10-19.—Servicing controls and indicators.

NOTE: The number in parentheses following a component name refers to figure 10-13.

CHARGING AN EXTERNAL SYSTEM.—

Before charging a system, prepare the oxygen servicing unit as outlined below. Three methods can be used to charge an aircraft system with the A/U26U-1: direct servicing from the oxygen cylinder (referred to as the “pressure equalization” or “cascade” method); boost pump using nitrogen drive; and boost pump using air drive. Prepare the servicing unit for charging an external system as follows:

1. Perform a preoperational inspection on the oxygen servicing unit in accordance with its preoperational checklist.

NOTE: When servicing a low-pressure (0 to 500 psi) system, ensure that the oxygen supply pressure gauge indicates greater than 250 psi. Install a fully charged oxygen cylinder if the gauge indicates less than 250 psi. If the pressure is greater than 650 psi, use the pressure equalization delivery method. If the pressure is less than 650 psi, use the boost pump. When

servicing a high-pressure system, ensure that the oxygen supply pressure gauge indicates greater than 450 psi. Install a fully charged oxygen cylinder if the gauge indicates less than 450 psi. If the pressure is greater than 2,150 psi, use the pressure equalization delivery method. If the pressure is less than 2,150 psi, use the boost pump.

2. Determine the pressure of the system to be charged.
3. Position the unit sufficiently close to the system to be charged to avoid stretching the servicing hose.
4. Attach the servicing hose and valve with the appropriate servicing adapter (figure 10-18) to the oxygen service connection on the oxygen module. (See figure 10-16, right side view.)
5. Verify that all valves on the servicing unit are either OFF or closed.
6. Ensure that the oxygen regulator on the oxygen module reads zero.

WARNING

Do not use this unit except for oxygen servicing. Do not interchange or substitute any components of this system with those of other systems. To do so may either cause an explosion or contaminate this system. Always open all valves slowly. If a leak is discovered during any phase of operation, immediately shut down the system.

Direct Servicing From The Oxygen Cylinder.—When charging an external system directly from the oxygen cylinder using pressure equalization, follow these steps:

1. Prepare the unit for operation as previously described.

NOTE: The number in parentheses following a component name refers to figure 10-13.

2. Open the oxygen cylinder valve (4), and observe the oxygen supply pressure gauge (19). Ensure oxygen pressure is adequate as previously describe.
3. Position the selector valve (20) to BYPASS, allowing oxygen to flow through the purifier (26) and filter (27) to the pressure regulator (30). Oxygen cylinder pressure should be indicated on the regulator inlet pressure gauge (29).
4. Rotate the pressure regulator (30) handle clockwise until the regulator outlet pressure gauge reads the desired servicing pressure.
5. Purge the servicing hose (33) by opening the servicing hose valve (34) for a few seconds, and then attach the servicing adapter (36 or 38) to the system to be charged.
6. Begin delivering oxygen to the aircraft system by opening the servicing hose valve (34).
7. When the aircraft system gauge indicates the desired pressure, close the servicing hose valve (34).
8. If no other system is to be serviced immediately, shut the unit down as described under SHUTDOWN PROCEDURES.

Boost Pump Using Nitrogen Drive.—When using nitrogen to drive the boost pump during an external charging operation, follow these steps:

1. Prepare the unit for operation as previously described.

2. Position the selector valve (20) to BOOST.
3. Open the oxygen cylinder valve (4).
4. Open the nitrogen cylinder valves (3), and nitrogen will flow to the nitrogen supply pressure gauge (6) and valve (7).
5. Verify that the nitrogen supply pressure gauge (6) indicates a pressure greater than 200 psi. If it indicates less than 200 psi, recharge the gaseous nitrogen system.
6. Open the nitrogen supply valve (7), allowing nitrogen to flow through the filter (8) and preset regulator (9) to the boost pump drive valve (15). The boost pump drive pressure gauge (12) should indicate 115 to 125 psi.
7. Open the boost pump drive valve (15), which allows nitrogen to flow to the boost pump. The boost pump (21) should begin to operate. The pilot valves will function to control the operation of the boost pump as previously described.
8. Verify that a pressure of 2,300 to 2,500 psi is indicated on the oxygen module regulator inlet pressure gauge (29).
9. Rotate the handle of the oxygen regulator (30) clockwise until the regulator outlet gauge (31) indicates the desired pressure.
10. Purge the servicing hose assembly, and continue with the servicing operation as previously described.

Boost Pump Using Air Drive.—When using compressed air to drive the boost pump during an external charging operation, follow these steps:

1. Prepare the unit for operation as previously described.
2. Position the selector valve (20) to BOOST.
3. Open the oxygen cylinder valve (4).

CAUTION

Use clean dry compressed air for boost pump drive. Ship/shop air pressure ranges 90 to 150 psi. Purge the air line before connecting it to the servicing unit.

4. Purge the ship/shop air supply hose, connect the air hose to nitrogen module ship air connection

(13), and open the ship/shop air supply valve. The boost pump drive pressure gauge (12) should indicate 90 to 150 psi.

5. Open the boost pump drive valve (15), which allows the air to flow to the boost pump. The boost pump (21) should begin to operate. The pilot valves will function to control the operation of the boost pump as previously described.
6. Verify that a pressure of 2,300 to 2,500 psi is indicated on the oxygen module regulator inlet pressure gauge (29).
7. Rotate the handle of the oxygen regulator (30) clockwise until the regulator outlet gauge (31) indicates the desired pressure.
8. Purge the servicing hose assembly, and continue with the servicing operation as previously described.

SHUTDOWN PROCEDURES.—To avoid injury to personnel and damage to equipment, the oxygen servicing unit must be properly shut down after an external charging operation. The shutdown procedures to be used depend on the method of servicing used—pressure equalization or boost pump.

Pressure Equalization Shutdown.—Use the following steps to shut the oxygen servicing unit down after using the pressure equalization method for recharging an external system:

1. Close the oxygen servicing unit servicing valve (34).
2. Close the oxygen cylinder valve (4).
3. Open the oxygen vent valve (28). The oxygen supply pressure gauge (19) and regulator inlet pressure gauge (29) should drop to zero.
4. Rotate the handle of the oxygen regulator (30) counterclockwise and hold it in this position until the regulator outlet gauge (31) indicates zero.
5. Position the selector valve (20) to OFF.
6. Position the oxygen vent valve (28) to OFF.
7. Disconnect the servicing adapter (36 or 38) from the aircraft oxygen storage system.
8. Disconnect the servicing hose assembly (33, 34, 35, and 36 or 38) and store it in the nitrogen module storage compartment.

Oxygen Boost Pump Shutdown.—Use the following steps to shut the oxygen servicing unit down after using the boost pump to recharge an external system:

1. Close the oxygen servicing unit servicing valve (34).
2. Close the nitrogen boost pump drive valve (15).
3. Close the nitrogen cylinder valves (3) or ship/shop air supply valve.
4. Close the oxygen cylinder valve (4).
5. Open the oxygen vent valve (28).
6. Open the nitrogen boost pump drive vent (16).
7. Rotate the handle of the oxygen regulator (30) counterclockwise and hold it in this position until the oxygen regulator outlet pressure gauge indicates zero.
8. Close the oxygen vent valve (28) when the oxygen supply pressure gauge (19) and regulator inlet pressure gauge (29) indicate zero.
9. Close the boost pump drive vent (16) when the nitrogen supply pressure gauge (6) and boost pump drive pressure gauge (12) indicate zero.
10. If open (depending on whether ship/shop air was used), close the nitrogen supply valve (7).
11. Position the oxygen selector valve (20) to OFF.
12. Disconnect the servicing adapter and hose assembly and stow them as previously described.

RECHARGING THE NITROGEN CYLINDERS.—Use the following steps to recharge the nitrogen cylinder on the A/U26U-1:

1. Position the servicing unit near the external nitrogen source and set the brake.

CAUTION

Ensure that the nitrogen recharging source regulator outlet pressure is set at 3,500 psi with a pressure relief device set at 4,000 psi.

2. Purge the external nitrogen source recharge hose.

3. Remove the plug from the nitrogen module recharge connection (figure 10-15, left side view) and attach the recharge hose to the connection.

NOTE: The number in parentheses following a component name refers to figure 10-13.

4. Ensure that the oxygen servicing unit's nitrogen cylinder valves (3), nitrogen module supply valve (7), and boost pump drive vent valve (16) are closed/OFF.
5. Open the nitrogen recharge source servicing valve.
6. Open the servicing unit's nitrogen cylinder valves (3).
7. Close the nitrogen recharge source servicing valve when the servicing unit's nitrogen module supply pressure gauge (6) indicates 3,500 psi.
8. After ensuring that the cylinders (1) are fully charged, close the cylinder valves (3).
9. Vent the recharge unit servicing hose by opening the nitrogen supply pressure valve (7) and boost pump drive vent (16) on the oxygen servicing unit.
10. Close all valves on the oxygen servicing unit when its nitrogen supply pressure gauge (6) and boost pump drive pressure gauge (12) indicate zero.
11. Disconnect the external nitrogen recharge hose.
12. Install the plug on the nitrogen module recharge connection.

Replacing The Oxygen Cylinder

The oxygen cylinder on the A/U26U-1 servicing unit can not be recharged without removing it from the trailer; therefore, you must replace an empty cylinder with a full one.

NOTE: Never completely expend the oxygen supply from a cylinder. The cylinder should have a minimum of 25 psi when removed from the servicing unit.

REMOVING THE EMPTY CYLINDER.—

When cylinder pressure is low, the cylinder is removed as described in the steps below: (Refer to figures 10-12 and 10-14.)

1. If possible, fasten the servicing unit to a towing vehicle before unloading the cylinder so that the trailer does not become unbalanced and tilt

backward. If a towing vehicle is not available, lock the swivel caster in the DOWN position and apply the hand brake.

2. Close the oxygen cylinder valve.
3. Bleed pressure from the line before disconnecting the hose.
4. Disconnect the oxygen hose from the cylinder valve.
5. Install the cylinder safety cap.
6. Unlatch the oxygen cylinder clamp assembly. (See figures 10-12 and 10-14.)
7. Remove the empty cylinder.

INSTALLING THE FULL CYLINDER.—

Follow these procedures to install a full cylinder on the servicing unit:

1. If possible, fasten the servicing unit to a towing vehicle before loading the cylinder so that the trailer does not become unbalanced and tilt backward. If a towing vehicle is not available, lock the swivel caster in the DOWN position and apply the hand brake.
2. Ensure a safety cap is installed on the oxygen cylinder to be loaded.
3. Load the fully charged cylinder on the trailer rack.
4. Position the cylinder for proper weight distribution.
5. Close the clamp assembly around the cylinder and latch it in the fully closed position.
6. Manually check the cylinder for movement and, if necessary, tighten the clamp assembly by positioning the hook bolt adjustment nut.
7. Remove the safety cap.

NOTE: Before connecting the hose to the cylinder, crack (open) the cylinder valve slightly to blow any foreign matter from the outlet of the valve. Then close the valve.

8. Connect the oxygen hose to the cylinder valve. Be careful to ensure the hose is not twisted when tightened.
9. Connect the cylinder grounding clamp and strap between the hose fitting and cylinder valve.

After replacing the empty cylinder, the cylinder valve should remain closed until the unit is to be used to service an aircraft system.

WARNING

Relieve all system pressure before performing maintenance on any part of the oxygen servicing unit.

Maintenance of the A/U26U-1

NOTE: All maintenance on the A/U26U-1 oxygen servicing unit shall be performed in accordance with NAVAIR 19-25D-31, *Operation and Intermediate Maintenance Instructions with Illustrated Parts Breakdown, Oxygen Servicing Unit, A/U26U-1* and NAVAIR 19-600-269-6-2, *Periodic Maintenance Requirements Manual, Oxygen Servicing Unit, A/U26U-1*.

Aviation Support Equipment Technicians perform organizational- and intermediate-level maintenance on the oxygen servicing unit. Maintenance includes loading, charging, and replacing cylinders; miscellaneous parts repair and replacement; and inspections. Procedures for testing and troubleshooting the servicing unit to isolate defective components/parts are outlined in NAVAIR 19-25D-31.

WARNING

Interchanging parts between oxygen servicing equipment and air/nitrogen equipment is a serious safety hazard. All components coming in contact with oxygen shall be cleaned in accordance with MIL-C-52211, Class A.

The maintenance actions performed on the oxygen servicing unit are similar to those performed on the nitrogen servicing unit, discussed in chapter 9. Some of the components of the systems are very similar and, in some cases, look identical; however, the components can NOT be interchanged. The cleanliness standards for oxygen system components far exceeds those for nitrogen system components. To make it nearly impossible to interchange similar parts between oxygen and air/nitrogen equipment, critical parts for oxygen equipment (valves, regulators, and hoses) have left-hand threads. This means that to tighten oxygen hoses, you turn the fitting counterclockwise—just the opposite of the way you tighten air/nitrogen hoses.

The importance of using only those replacement parts specified by NAVAIR 19-25D-31 cannot be over emphasized. All hose and tube assemblies shall be suitable for oxygen use as specified by NAVAIR 01-1A-20, *Aviation Hose and Tube Manual*. Apply tetrafluoroethylene tape to pipe threads, starting at the third thread to prevent contamination, before assembly. Apply antiseize compound to screw threads and bearing surfaces of nuts and bolts before torquing them to specification.

SAFETY

Oxygen can be very dangerous. In all of its forms, it supports fire and is subject to explosion. As a compressed gas, the principal danger is due to the rocket-like thrust imparted to a cylinder by the sudden and rapid escape of gas. For example, if the valve of a cylinder pressurized at 2,500 psig were broken off, the cylinder would have an initial thrust of about 2,600 pounds of force. The cylinder could attain a velocity of 50 feet per second in about one-tenth of a second.

Another potential hazard results from the increase in pressure of a compressed gas with any increase in temperature. Cylinders may explode with great violence. Safety plugs may blow out if cylinders are exposed to higher than normal temperatures.

Cylinders must be handled with care. Mechanical or structural damage may result in cylinders that are unable to withstand normal use. Serious accidents connected with handling, using, and storing of cylinders have often been traced to abuse or mishandling.

When handling oxygen, you must follow these precautions:

- Always call oxygen by its proper name. Do not confuse oxygen with compressed air. NEVER use oxygen in place of compressed air for any purpose.
- In aircraft gaseous oxygen systems, use only oxygen conforming to MIL-0-27210, Type I.
- Exercise care that compressed oxygen does not become contaminated in any way with hydrogen, hydrocarbon gases, or oil-based liquids. Oxygen contaminated with any of these substances can explode.
- NEVER lubricate oxygen valves, regulators, gauges, or fittings with oil or any substance except an approved oxygen compatible

lubricant, such as stopcock grease (MIL-G-27617). A spark is not necessary to cause a fire or explosion. The chemical reaction that results from mixing hydrocarbons with oxygen is sufficient to develop spontaneous combustion.

- Do not allow sparks or flames from a welding or cutting torch to contact an oxygen cylinder. For that matter, keep all sparks and flames away from oxygen cylinders.
- NEVER use oxygen from a cylinder without reducing the pressure through a pressure-reducing regulator.
- NEVER use oxygen to test pipes for leaks or to blow out pipe lines, unless the lines are specifically made and cleaned for oxygen use. Use water-pumped, dry nitrogen for this purpose, because nitrogen does not support combustion.

WARNING

Pipes, pipe threads, and other pressure containers are sometimes greased or oiled. The use of compressed oxygen for the general purpose of testing for leaks is extremely dangerous and almost certain to cause a violent explosion.

- Always close valves and replace caps when cylinders are not in use.
- Handle cylinders carefully. Rough handling, knocks, or falls may damage cylinders, valves, or safety devices, causing leaks. A more serious consequence could result from a broken valve, which could cause the rapidly escaping gas to impart a rocket-like thrust to the cylinder.
- Before making a connection to a cylinder valve, open the valve slightly, and then close it immediately. This action, called *cracking*, clears the valve of particles of dust or dirt that otherwise might enter the connection.
- If a valve is difficult to open, point the valve opening away from your body and use greater force. You should be able to exert enough pressure with your hand to open or close the

valve. Using a wrench or hammer to open a valve is not recommended.

- Do not tamper with safety devices on the cylinders.
- NEVER allow the pressure in oxygen storage cylinders that service aircraft to fall below 50 psig. Oxygen cylinders depleted to a pressure of approximately 50 psi are marked “EMPTY,” tagged, and stored separately from charged oxygen cylinders. All cylinders in which the pressure has been allowed to fall below 15 psig must be removed from service and decontaminated by a heat-vacuum treatment (MIL-C-7796).
- NEVER refill an oxygen cylinder that has gone beyond its hydrostatic test date (5 years after the last test date stamped on the shoulder of the cylinder).

Consult NAVAIR 06-20-2, *Gas Cylinders*, for the latest information on cylinders (storage type), use, handling, and maintenance.

OXYGEN SURVEILLANCE

Liquid oxygen requires continuous monitoring to detect the presence of contamination. The Navy’s primary way of ensuring that each operation in the LOX supply system is carried out in strict compliance with established procedures is the Aviators’ Breathing Oxygen (ABO) Surveillance Program. Surveillance begins with the procurement or generation of LOX by Navy and Marine Corps activities, and continues during the storage, handling, transfer, and servicing of aircraft. The Navy coordinates its program with the Air Force, ensuring a safe supply of LOX at U.S. facilities worldwide.

Personnel who perform operations in the ABO Surveillance Program should have a thorough knowledge of the characteristics of oxygen in both its liquid and gaseous states. They should also understand the significance of contamination in breathing oxygen, and the need for quality control.

Q10-15. Aviators’ breathing oxygen cylinders have which of the following paint schemes?

1. Green with one white band
2. Green with two white bands
3. Green with one light gray band
4. Green with two light gray bands

Q10-16. Which of the following sources is used to drive the boost pump on a gaseous oxygen servicing trailer when compressed air is not available?

- 1. An electric motor*
- 2. A nitrogen source*
- 3. A hand pump*
- 4. A hydrostatic motor*

Q10-17. On the A/U26U-1 servicing trailer, a gaseous oxygen cylinder can be charged to what maximum pressure?

- 1. 2,000 psi*
- 2. 2,400 psi*
- 3. 3,000 psi*
- 4. 3,500 psi*

Q10-18. The boost pump for the oxygen module has which of the following compression ratios?

- 1. 5:1 to 8:1*
- 2. 5:1 to 16:1*
- 3. 15:1 to 26:1*
- 4. 25:1 to 36:1*

Q10-19. Which of the following is NOT a method of charging an aircraft system with the A/U26U-1?

- 1. Indirect regulator flow*
- 2. Pressure equalization*
- 3. Boost pump using nitrogen drive*
- 4. Boost pump using air drive*

Q10-20. Which of the following compressed pressures should you expect to get from ship/shop air pressure lines?

- 1. 90 to 150*
- 2. 160 to 190*
- 3. 195 to 200*
- 4. 210 to 220*

Q10-21. All components that come in contact with oxygen shall be cleaned in accordance with which of the following publications?

- 1. MIL-C-55221, Class C*
- 2. MIL-C-55522, Class B*
- 3. MIL-C-52211, Class A*
- 4. MIL-C-51221, Class D*

Q10-22. Which of the following programs was established to ensure strict compliance with all procedures concerning the LOX supply system?

- 1. The Liquid Oxygen (LOX) Manufacturing and Procurement Program*
- 2. The Liquid Oxygen (LOX) and Gaseous Oxygen Surveillance Program*
- 3. The Aviators' Breathing Oxygen (ABO) Surveillance Program*
- 4. The Aviators' Breathing Oxygen (ABO) Manufacturing and Procurement Program*

CHAPTER 11

MOBILE AIR-CONDITIONERS

INTRODUCTION

Mobile air-conditioners are primarily designed to remove heat produced by operating electronic equipment. Along with the removal of heat, these units also reduce the humidity within electronic equipment spaces. Although air conditioning is usually thought of as a lowering of temperature, air can be conditioned by cooling, heating, filtering, or dehumidifying. Modern mobile air-conditioners are designed to accomplish all of these functions.

Mobile air-conditioners are referred to as mechanical refrigeration systems because of the means used to circulate a refrigerant through a closed system to accomplish heat transfer. For you to understand the basic principles of refrigeration, you need to understand the relationship of heat, temperature, and pressure.

REFRIGERATION PRINCIPLES

LEARNING OBJECTIVES: Identify the principles of air-conditioning. Identify the refrigeration cycle and the different types of air-conditioners.

MATTER DEFINED

Matter is anything that has weight and occupies space. All substances are forms of matter in one of three stages: solid, liquid, or gaseous. An example of a substance with three stages is water.

In its natural state water is a liquid. It has weight and volume, and takes the shape of the container that holds it. If it is heated in a closed container to its boiling point and more heat is added, it changes to steam (vapor), which is its gaseous state. It has weight and occupies the volume of the container. When water is frozen, it changes to its solid state (ice). In this state it has weight and volume, and it takes a definite shape.

Theoretically, all substances can be converted from one to another of the three states by the addition or withdrawal of heat. However, chemical compounds differ in the ease or difficulty with which they may be changed from one to another of the three physical states. Some, like water, can very readily be converted

into each of the three states. Others, like paper, oxidize, or burn, at high temperatures and cannot be converted into all three. Before paper burns, it changes to a gas, but never to a liquid. The science of refrigeration depends upon changes in physical state through heating or cooling.

HEAT AS ENERGY

Heat is a form of energy. It cannot be seen or shaped. It cannot be created or destroyed. It can only be transferred from one substance to another.

All substances are made up of tiny molecules. These molecules are in constant motion and moving against each other. As the temperature of the molecules increases, so does their activity. As heat is taken away, their activity and temperature decrease. If all heat is extracted from a substance (absolute zero temperature), the molecular motion will become dormant.

COLDNESS AND HEAT

Coldness and heat are relative terms. Strictly speaking, coldness is not a distinct condition separate from hotness. The two terms are purely relative, without exact meanings. They merely express temperature conditions with reference to a standard. For us, this standard is usually the temperature of the human body, which is normally about 98.6°F. If a person picks up a piece of ice, he says the ice is cold; he means that its temperature is lower than the temperature of his hand. If he drinks a cup of coffee, he says the coffee is hot; he means merely that its temperature is higher than that of his mouth. Nevertheless, the ice is warmer than liquid air, for example, and the coffee is cooler than boiling water.

In matters pertaining to refrigeration and air conditioning, it is sometimes preferable to use the expression *cooling*, rather than the awkward expression *removing heat*. When cooling is used, it is understood that the operation actually consists of removing heat.

MEASUREMENT OF HEAT

From experience we know that heat and temperature are related. If heat is added to a substance,

the temperature of the substance will rise. If heat is taken away from a substance, the temperature of the substance will decrease.

In discussing heat, we need to make a distinction between intensity and quantity. It will help to compare a spoonful of hot water to a pailful of warm water. The spoonful of hot water contains a greater intensity of heat, but the warm water in the pail possesses a greater quantity of heat, because of its greater mass.

Intensity of Heat

Intensity of heat is measured by the ordinary thermometer with which everyone is familiar. The two methods of dividing and numbering the thermometer scales in common use are the Fahrenheit scale and the Centigrade scale. (Another scale not so commonly used, except by scientists, is the Kelvin scale.)

Quantity of Heat

The quantity of heat possessed by a substance is measured in terms of the British thermal unit (Btu). A Btu is the quantity of heat required to raise the temperature of 1 pound of pure water 1 degree Fahrenheit at or near 39.1°F. This is the temperature at which water is at maximum density. For example, to raise the temperature of 5 pounds of water from 39°F to 49°F requires 50 Btu ($5 \text{ lb} \times 10^\circ\text{F} = 50 \text{ Btu}$). For all practical purposes, the Btu is considered constant between 32°F and 212°F, though it does vary a slight amount.

TYPES OF HEAT

For a full understanding of the principles of air conditioning, you must understand the terminology of the science. One aspect of that is the way in which heat is classified. We have already discussed intensity of heat, which is measured by a thermometer, and quantity of heat, which is measured in Btu. The different types of heat are discussed here.

Specific Heat

Specific heat is the number of Btu that must be added to a unit weight of substance to raise its temperature 1 degree Fahrenheit. (The unit weight is normally considered to be 1 pound.) Technically, the specific heat of a substance is the ratio of the amount of heat required to change the temperature of the same weight of water 1 degree. Since the specific heat of water is, by definition, equal to 1, the specific heat of

other substances are expressed as decimals. Table 11-1 shows examples of the specific heat of some substances.

Table 11-1.—Specific Heat

Material	Specific Heat (Btu/lb)
Water	1.000
Ice	.504
Wood	.327
Iron	.129
Copper	.095
Glass	.187
Mercury	.033
Alcohol	.615

Thermal Capacity

Thermal capacity is closely related to specific heat. The specific heat of a substance is the number of Btu necessary to raise the temperature of 1 pound of the substance 1 degree Fahrenheit. The thermal capacity of a substance is the amount of heat required to raise the temperature of its whole weight 1 degree. Hence, thermal capacity equals the specific heat of a substance multiplied by its weight. Thermal capacity may be said to express the total capacity of a given quantity of a substance for absorbing and storing heat. Thermal capacity is stated, not as a ratio, but as a certain number of Btu.

Sensible Heat

Heat that is added to, or subtracted from, a substance that changes its temperature but not its physical state is called *sensible heat*. Sensible heat is the heat that can be indicated on a thermometer. For example, if you heat a cup of water from 50°F to 70°F, its temperature increases 20 degrees but the water stays in its liquid state.

Sensible heat is the heat that human senses can also react to, at least within certain ranges. For example, if a person puts his finger into a cup of water, his senses readily tell him whether it is cold, cool, tepid, hot, or very hot. Human senses are not sufficiently discriminating to give precise information about the extreme temperatures of ice and steam or other substances having temperatures beyond the range of human sensory mechanisms. Ice merely seems cold and steam seems hot whatever their temperatures.

Latent Heat

Heat absorbed, or given up, during the conversion of a substance from one physical state to another has another name. This is called *latent heat*. (Latent is taken from the Greek language meaning hidden.) Latent heat has two forms: latent heat of fusion and latent heat of vaporization. When latent heat is added to or subtracted from a substance, and the physical change takes place, there is no change in the sensible heat or temperature of the substance.

LATENT HEAT OF FUSION.—If heat is applied to a piece of ice at a temperature of 0°F, the temperature of the ice will gradually rise. This change in temperature, which can be measured by a thermometer, is called *sensible heat*. No change in state takes place, only a change in the temperature of the ice.

As more sensible heat is added, the temperature of the ice finally reaches 32°F. Now, as more heat is absorbed by the ice, the ice melts or changes state, but the temperature of the liquid remains constant at 32°F until the ice is completely melted. The heat added during the process of melting the ice at 32°F to water at 32°F is the hidden or latent heat of fusion.

This process also works in reverse. When water is chilled to 32°F and more heat is taken away to form it into ice at 32°F, this heat is also latent heat of fusion.

What is demonstrated here is one of the most important laws in physics; heat can never be destroyed. It can only be transferred from one substance to another. So the same amount of heat required to melt the ice into water must be removed from the water to convert it back to ice.

The latent heat of fusion for pure water at 32°F and at sea level is 143.33 Btu per pound.

LATENT HEAT OF VAPORIZATION.—As the last of the ice melts, the temperature of the water begins to rise. The temperature causing the rise is sensible heat. When the temperature of water reaches 212°F, the temperature stops rising and another change takes place. More heat is added and the water boils or changes to steam, but there is no change in temperature. This too is hidden heat. As the last of the water vaporizes and more heat is added, the temperature will again rise, and again we are dealing with sensible heat.

The heat added to, or taken away, in the process of changing water to steam (vapor), or from steam back to

water, is called *latent heat of vaporization*. All substances that change from liquid to a vapor or gas go through this stage. The amount of heat required to convert 1 pound of water at 212°F into steam, or to convert steam to water, is 970.4 Btu.

Total Heat

In refrigeration and air conditioning, the total heat of a substance, or of the air in a room, is all the heat present; that is:

Total heat = sensible heat + latent heat.

In discussions, the term *heat content* is sometimes used. This term has the same meaning as *total heat*.

Superheat

If a vapor is not in contact with a boiling liquid, either because the liquid has been completely converted to vapor or because the vapor has been separated from the boiling liquid, further application of heat produces a rise in temperature of the vapor, which is called *superheating*. To meet the definition for superheat, there must be no liquid present.

HEAT TRANSFER

As stated earlier, heat can be neither created nor destroyed; it can only be transferred from one object to another. There are three laws that govern heat transfer:

- Heat always flows from a hot object to a cooler one.
- The greater the difference in temperature, the faster the heat flows.
- Heat will continue to flow until all temperatures equalize.

The transfer of heat can be accomplished in one of three ways: radiation, convection, or conduction.

Radiation

In radiation, heat is transferred through an empty space (a vacuum) or through the atmosphere. Radiation does not heat the air through which it passes; it heats only the objects upon which it falls. Not only the sun, but other objects such as stoves, flames, light bulbs, machines, and even the earth itself radiate heat. Even our bodies radiate heat.

Convection

Convection is the transfer of heat by the movement of a medium (gas or liquid) through a space. Examples of this include a current of warm air through a room and warm air rising from a steam or hot water radiator.

Conduction

The transfer of heat from one molecule to another, either of the same substance or of different substances, by direct contact is called *conduction*. Physical contact is necessary for conduction of heat, and the conduction takes place from the region of higher temperature to the region of lower temperature. For example, if you take a metal bar and place one end of it into a flame, the heat passes from the flame to the bar, and then along the bar to your hand. Here, physical contact is made in each instance; flame to bar, bar to hand.

Suppose that you hold two metal bars in a flame, each of equal size, one bar of iron and the other of copper. The heat conducted through the bar of copper will reach your hand more quickly than through the bar of iron because some substances conduct heat more readily than others. This characteristic of a substance is called *thermal conductance*. The low or high thermal conductance of a material is of great importance in refrigeration and air conditioning. Some materials are used for heat transfer, while other materials are used to prevent heat transfer (insulators).

PRESSURE-TEMPERATURE RELATIONSHIPS

Pressure has a definite relationship to the boiling point of any liquid. As pressure is exerted on a liquid, the temperature required to reach the boiling point of the liquid also increases. Inversely, as you decrease the pressure exerted on a liquid, the boiling point will also decrease.

If an uncovered container filled with fresh water at sea level is heated until the water boils, a thermometer inserted in the water will show that its temperature is 212°F, and a barometer will show that the atmospheric pressure is about 14.7 psi. However, if the same pot of water is placed on a hilltop 1,000 feet above sea level, at boiling point the thermometer will read 210°F, and the barometer will show an atmospheric pressure of about 14.14 psi. Similar variations in boiling point and barometric pressure are observed at different altitudes, as indicated in table 11-2.

Table 11-2.—Boiling Points of Water

Feet Above Sea Level	Pressure (psi)	Boiling Point of Water (°F)
Sea level	14.70	212
2,000	13.57	208
4,000	12.49	204
6,000	11.54	200
8,000	10.62	196

It is not variations of pressure and temperature at different altitudes that we are particularly interested in, but the relationship between the temperature of vaporization (boiling point) and the corresponding pressure. And, it is not necessary to go to different heights to obtain different pressures; different pressures can be obtained by mechanical means at any location.

For example, a boiling liquid and its vapor may be contained in an airtight metal cylinder with a piston. By moving the piston in or out, the pressure within the cylinder can be increased or decreased. If the piston is pushed in, thus increasing the pressure inside, a thermometer will show that the change of state from liquid to vapor requires a temperature higher than 212°F. If the piston is pulled out, thus decreasing the pressure within the cylinder, the thermometer shows that the change of state from liquid to vapor takes place at a temperature lower than 212°F. This relationship of vaporization temperature and pressure, which varies for different substances, follows an exact law, and may be tabulated accurately for almost any substance.

APPLIED LAWS

As stated earlier, there are many laws that state how liquids and gases behave under different conditions. Understanding these laws will help you understand the operation of any type of equipment that uses compression of liquids or gases. The three most important laws of compressed gases are Boyle's Law, Charles' Law, and Dalton's Law.

Boyle's Law

Boyle's law states: "The volume of a gas varies inversely to the pressure, provided the temperature remains constant."

Let's take a closer look at this and see what it really means. If you apply pressure to a gas, the volume will decrease proportionally. Thus, if you double the pressure exerted on a gas, its volume will become half of what it was. On the other hand, if you reduce the pressure exerted on a gas by one-half, the volume of that gas will double.

Remember, the temperature must remain constant. If the temperature goes up or down, then Boyle's law does not apply.

Charles' Law

Charles' law states: "At a constant pressure, the volume of a compressed gas varies directly to the absolute temperature; at a constant volume, pressure varies directly to the absolute temperature."

Now, let us consider what this means. If you raise the temperature of a compressed gas, the volume will increase proportionally with the increase in temperature. The effect works in reverse if you decrease the temperature.

An example of the effect of this law is seen in the downstroke of the piston of an internal combustion engine. As the air-fuel mixture is ignited, the temperature increases and the volume of gas in the cylinder expands, pushing the piston down.

Dalton's Law

Dalton's law states: "The total pressure of a confined mixture of gases is the sum of the pressures of each of the gases in the mixture."

This means that if you have a mixture of gases in a cylinder, the pressure in the cylinder is a total of all the pressures of all the gases in that cylinder. For example, if you have a cylinder that contains 10 psi of oxygen, 20 psi of nitrogen, 35 psi of carbon dioxide, and 65 psi of helium, the total pressure in the cylinder will equal 130 psi. Also, each gas in the cylinder will act as if it were in the cylinder alone.

TERMINOLOGY

The following terms apply to the science of refrigeration and air conditioning.

BRITISH THERMAL UNIT—The amount of heat required to produce a temperature change of 1°F in 1 pound of pure water at sea level pressure.

CHANGE OF STATE—The change of any matter from one state (solid, liquid, or vapor) to another.

COMPRESSION—The act of increasing the pressure and temperature of a substance by decreasing its volume.

CONDENSATION—The process by which a vapor changes state to a liquid when heat is removed from the vapor.

CONDUCTION—Heat transfer from molecule to molecule within a substance or between two substances that are in physical contact with each other.

CONVECTION—Heat transfer through some easily circulated medium (usually liquid or vapor). As the medium moves, it carries contained heat energy, which is then transferred to the surroundings.

DEHUMIDIFY—To reduce the quantity of water vapor in a given space.

EVAPORATION—The process by which a liquid changes state to a vapor when heat is added to the liquid.

HEAT—A basic form of energy that is transferred by virtue of a temperature difference. Heat always flows from a hot object to a cold object; the greater the temperature difference, the faster the flow. Heat cannot be created or destroyed—only transferred.

HEAT OF CONDENSATION—The latent heat given up by a substance as it changes state from a vapor to a liquid.

HEAT OF FUSION—The latent heat absorbed as a substance changes from a solid to a liquid.

HEAT OF VAPORIZATION—The latent heat absorbed by a substance as it changes state from a liquid to a vapor.

LATENT HEAT—Heat applied to, or removed from, a substance that causes a change in the physical state of the substance, but not in its temperature.

REFRIGERATION CYCLE—The complete course of operation of a refrigerant (from starting point back to starting point) in a closed refrigeration system.

SENSIBLE HEAT—Heat applied to, or removed from, a substance that causes a change in the temperature of the substance, but not in its state.

SUPERHEAT—Heat added to a vapor above the boiling point of the liquid that produced the vapor. The

vapor and the liquid must be separated before the vapor can be superheated.

TEMPERATURE—A measure of the heat intensity or concentration of heat (thermal energy) in a body or substance, measured in degrees.

REFRIGERATION TON—The transfer of heat at a rate of 288,000 Btu in 24 hours (12,000 Btu in 1 hour).

VACUUM—Any pressure less than atmospheric pressure.

VAPOR—The gaseous form of any substance. Vapor condenses very readily to a liquid state under small changes of temperature or pressure, or both. It may be said to be very close to the liquid state, although it is a vapor.

REFRIGERANTS

A refrigerant is a substance that can easily be changed from a liquid state to a vapor state. Ideally, it is a substance with a low boiling point. It must also have the ability to absorb and carry heat at a low temperature. Finally, it must be able to transfer this absorbed heat to a cooling medium as it condenses.

Most refrigerants in use today require relatively low operating pressures within the system. Heavy construction is not required and the problem of leaking is minimized.

To prevent confusion and provide for a standard system, all refrigerants are assigned numbers instead of trade names. They are referred to as refrigerant 12, refrigerant 22, and so on.

Here, we will discuss refrigerant 12, for background information, and refrigerant 22, because that is the type currently used in the A/M32C-17 and the A/M32C-21 air-conditioners.

Refrigerant 12 (R-12)

Research for the perfect refrigerant resulted in R-12. It approaches that ideal more than any other refrigerant discovered so far. Its chemical name and symbol, dichlorodifluoromethane (CCl_2F_2), indicate that R-12 contains one part carbon, two parts chlorine, and two parts fluorine.

At atmospheric pressure, R-12 boils at -21.66°F . Its latent heat of vaporization is about 72 Btu per pound. This means that as R-12 changes state to a vapor, it absorbs 72 Btu per pound.

Some of the advantages of R-12 are as follows:

- It is nonflammable, nonexplosive, and non-corrosive.
- Its vapor is nontoxic.
- At the low-pressure point of its cycle, it operates at pressures slightly above atmospheric pressure. This minimizes the possibility of air entering the system.
- At the high-pressure point of its cycle, pressure is relatively low. This allows the use of light-weight equipment.

Refrigerant 22 (R-22)

R-22, like R-12, is a member of the fluorinated hydrocarbon family. Its chemical name and symbol, monochlorodifluoromethane (CHClF_2), indicate that R-22 contains one part carbon, one part hydrogen, one part chlorine, and two parts fluorine.

At atmospheric pressure, R-22 boils at -41°F . Its latent heat of vaporization is about 92 Btu per pound. This ability to absorb great amounts of heat, combined with its low boiling point, makes R-22 a very good refrigerant for systems of high capacity and low temperatures.

R-22 requires higher pressures in its cycle than R-12. As a result, slightly heavier construction is required. With this exception, all the advantages associated with R-12 also apply to R-22.

One inherent disadvantage that is shared by both R-12 and R-22 is their capacity to absorb water. If not controlled, moisture in the refrigerant can cause two serious problems. First, moisture reacts chemically with the refrigerant to form hydrochloric acid, which is a very corrosive substance. Second, moisture in the refrigerant tends to freeze, which can have a serious effect on system components, such as expansion valves. In most air-conditioning systems, chemical driers are used to control the level of moisture in the refrigerant.

Other Refrigerants

You should be aware that there are other refrigerants on the market (R-134A for one) that are not compatible with systems using R-22. Such other refrigerants are blends of existing refrigerants and, in some cases, are highly flammable. Some of these blend refrigerants may break down the desiccant in the receiver/drier and pass the debris into the rest of the

system, causing damage to the air-conditioner. Under no circumstances should you use any of these blend refrigerants to cross match to your R-22, and never mix R-22 with R-134A. You will only contaminate the system and cause damage to your equipment.

PRINCIPLES OF OPERATION

Operation of an air-conditioner is based on the principle that liquid refrigerant becomes cold as its pressure is reduced and it is allowed to vaporize. That cooling effect is then transferred to air spaces that require cooling for the operation of electronic equipment and the comfort of personnel.

Components

In figure 11-1, you see six major components of an air-conditioning system. These components are:

- The compressor
- The condenser
- The liquid receiver
- The heat exchanger
- The metering device (expansion valve)
- The evaporator

The following paragraphs will briefly explain how these components perform their functions.

Refrigeration Cycle

In explaining the refrigeration cycle, we must consider three aspects of the refrigerant at each stage of the process: whether the refrigerant is vapor (gas) or liquid, the degree of pressure it is under, and its relative temperature.

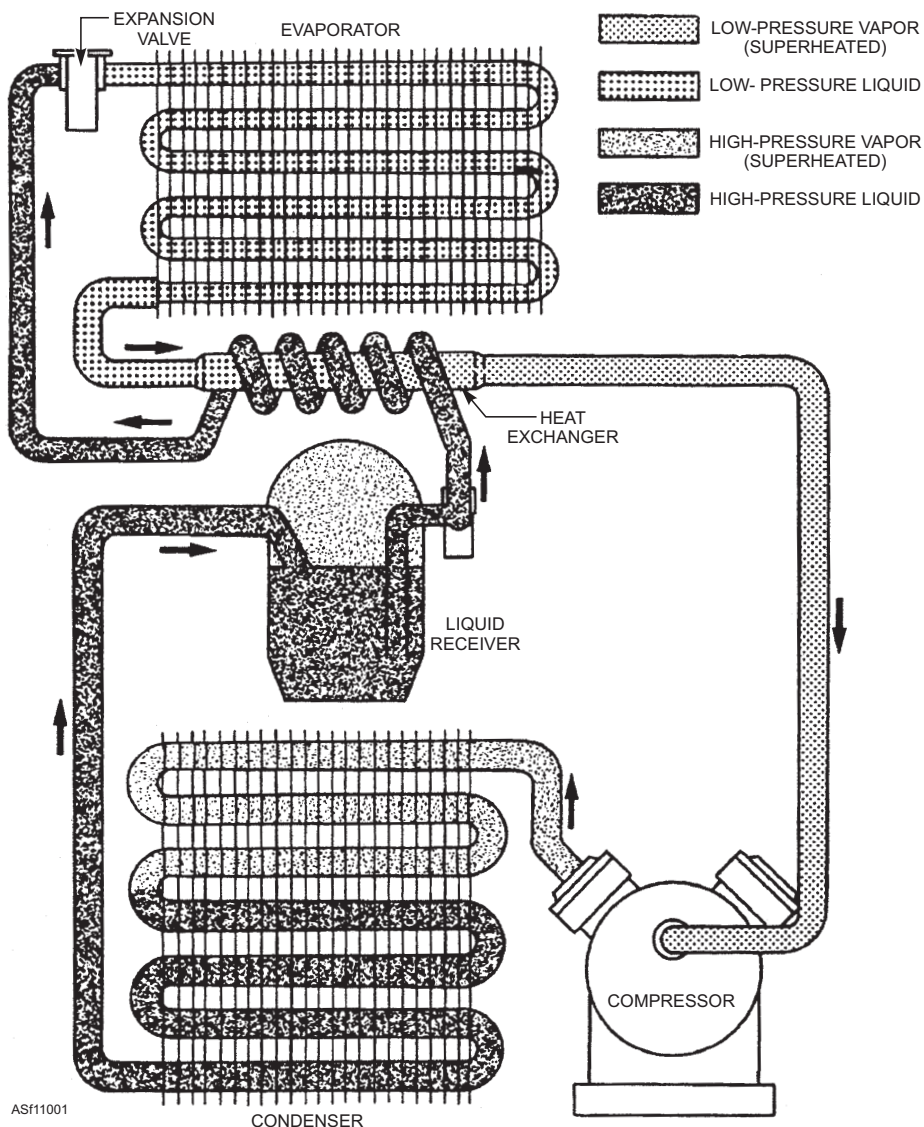

Figure 11-1.—Fundamental refrigeration cycle.

When the compressor is started, it draws refrigerant gas from the evaporator. The gas is normally cool and under low pressure when it enters the compressor. In the compressor, the gas is compressed (raises its pressure) and, in the process, becomes hot. The hot, compressed gas leaves the discharge side of the compressor and flows to the condenser. The condenser, which is surrounded by a cooling medium, such as air or water, dissipates some of the heat produced during the compression process. Removing the heat also causes the gas to condense into a liquid, which is still under high pressure. From the condenser, the liquid refrigerant flows to the receiver, which acts as a reservoir.

From the receiver, the liquid flows through the heat exchanger, where cool gas moving from the evaporator to the compressor dissipates more heat from the refrigerant. From the heat exchanger, the liquid travels to a metering device, such as an expansion valve. At the input side of the expansion valve, the liquid refrigerant is under high pressure. The metering process of the expansion valve lowers the pressure and temperature of the liquid refrigerant and feeds it to the evaporator.

The low-pressure liquid passing through the evaporator absorbs heat, causing it to boil (evaporate) and change back into a gas. This change, from liquid to gas, produces a cooling effect within the evaporator coils, and the coils become cold. The air to be cooled is then moved over the cold evaporator coils and directed into the space that is to be cooled. The gaseous refrigerant, now cool and under low pressure, is drawn back to the compressor, where it is again compressed and started back through the cycle.

Q11-1. The quantity of heat possessed by a substance is measured in terms of which of the following measurements?

1. Specific heat
2. Latent heat
3. Heat absorption level
4. British thermal unit

Q11-2. Heat added to a substance to raise the temperature 1 degree is known by which of the following terms?

1. Sensible heat
2. Specific heat
3. Latent heat
4. Total heat

Q11-3. Heat added to a substance, which changes its temperature but NOT its physical state, is known as what type of heat?

1. Sensible heat
2. Specific heat
3. Latent heat
4. Total heat

Q11-4. During the conversion of a substance from one physical state to another, heat absorbed or given up is known as what type of heat?

1. Sensible heat
2. Specific heat
3. Latent heat
4. Total heat

Q11-5. Heat that is added to a vapor to raise the temperature of the vapor is known as what type of heat?

1. Sensible heat
2. Super heat
3. Latent heat
4. Total heat

Q11-6. Which of the following is NOT a type of heat transfer?

1. Convection
2. Conduction
3. Absorption
4. Radiation

Q11-7. Which of the following laws states: "The volume of gas varies inversely to the pressure, provided the temperature remains constant?"

1. Dalton's law
2. Charles' law
3. Philip's law
4. Boyle's law

Q11-8. Which of the following laws states: "At a constant pressure, the volume of a compressed gas varies directly to the absolute temperature; at a constant volume, pressure varies directly to the absolute temperature"?

1. Dalton's law
2. Charles' law
3. Philip's law
4. Boyle's law

Q11-9. What term is used to identify the process by which a vapor changes state to a liquid when heat is removed from the vapor?

1. Condensation
2. Conduction
3. Dehumidification
4. Evaporation

Q11-10. Which of the following is one inherent disadvantage that is shared by both R-12 and R-22 refrigerant?

1. They both evaporate at very low temperatures
2. They are both very unstable compounds
3. They both have the capacity to absorb heat
4. They both have the capacity to absorb water

Q11-11. Which of the following is NOT a major component of an air-conditioning system?

1. A receiver
2. A condenser
3. A liquid exchanger
4. An expansion valve

COMPONENTS OF AN AIR-CONDITIONING SYSTEM

LEARNING OBJECTIVES: Identify the components of air-conditioners. Recognize the working relationships among air-conditioning components.

An air-conditioning system consists of six basic components—the compressor, the condenser, the liquid receiver, the heat exchanger, the metering device, and the evaporator. This configuration is typical of air-conditioners you are likely to encounter; however, you may find additional components in an air-conditioner. Refer to figure 11-1 for the relative locations of the major components.

COMPRESSOR

The compressor used in a refrigeration and air-conditioning unit has one purpose. It must withdraw the superheat-laden, low-pressure refrigerant vapor from the evaporator and compress it to such an extent that it liquefies in the condenser. The design of the compressor depends upon the application and type of refrigerant used in the system. There are three types of compressors, classified according to their principle of

operation. The types are reciprocating, rotary, and centrifugal (fig. 11-2).

The function of the compressor is the same for all three types, but the mechanical means used to accomplish this function differ considerably. The only type discussed in this manual is the reciprocating compressor, which is the type used in mobile air-conditioners. You are required to troubleshoot and maintain these units.

Reciprocating compressors used in air conditioning and refrigeration are designated as open, semi-hermetic, or hermetic. The open com-

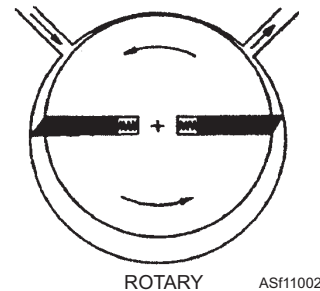
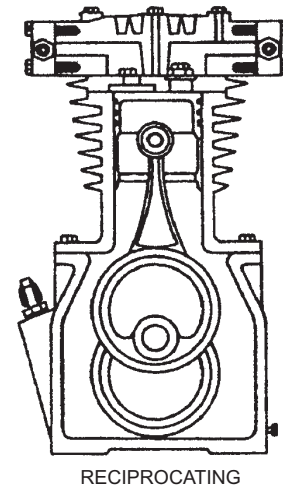
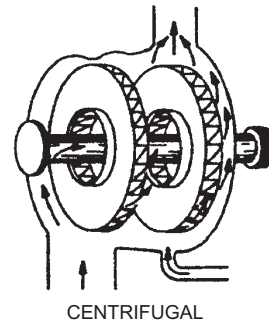

Figure 11-2.—Compressor types.

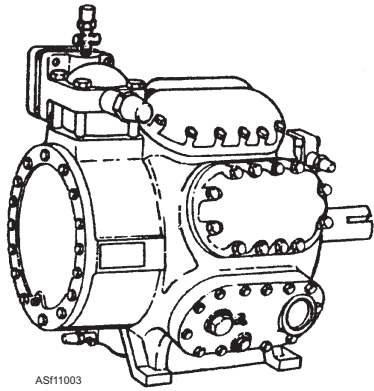

Figure 11-3.—Reciprocating open compressor.

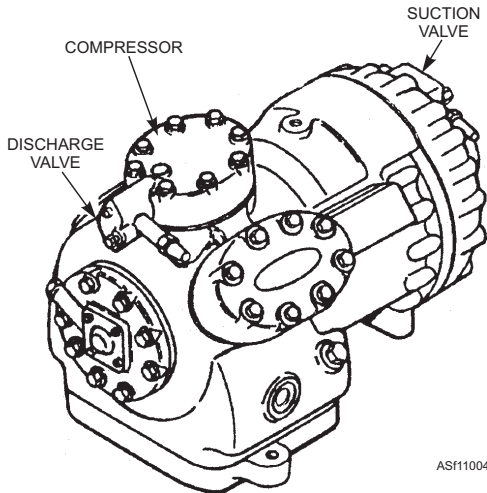

Figure 11-4.—Reciprocating semi-hermetic compressor.

pressor (fig. 11-3) is driven from an external power source through V belts, gears, or a flexible coupling. It is used on mobile air-conditioners powered by diesel engines and electric motors.

The semi-hermetic compressor (fig. 11-4) is a motor-compressor combination enclosed within a common housing. It is provided with access plates and can be serviced in the field if necessary. This compressor, in multi-cylinder versions (four or six), is

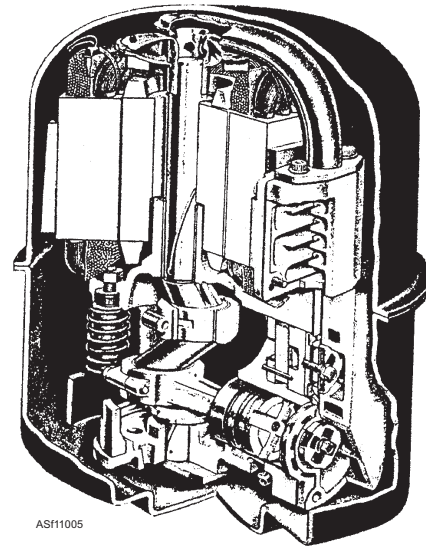

Figure 11-5.—Reciprocating hermetic compressor.

used on mobile air-conditioners. The A/M32C-21 unit uses this style in the 6-cylinder model.

The hermetic compressor (fig. 11-5) is a motor-compressor combination encased within a gastight, welded casing that cannot be opened for servicing except in refrigeration component overhaul shops. The hermetic compressors are used on refrigerators, freezers, window air-conditioners, and other small units.

The operation of all reciprocating compressors is basically the same. The piston and connecting rod are attached to a crankshaft, which is turned by the driving force. As the piston moves down toward its lowest position, a low-pressure area is formed within the cylinder. As indicated in view A of figure 11-6, the suction (intake) valve opens when the pressure within the cylinder becomes less than the pressure in the suction line leading to the cylinder. When the intake valve opens, the cylinder is filled with low-pressure refrigerant vapor.

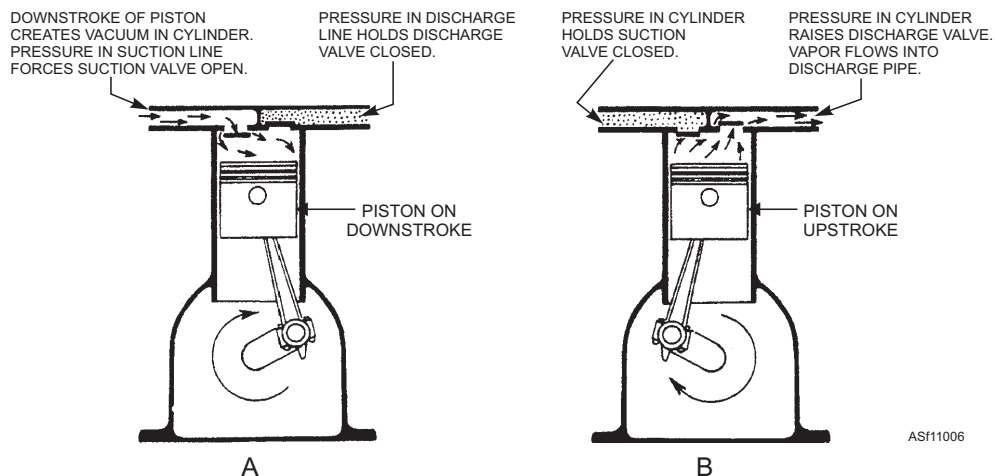

Figure 11-6.—Operating cycle of a reciprocating compressor.

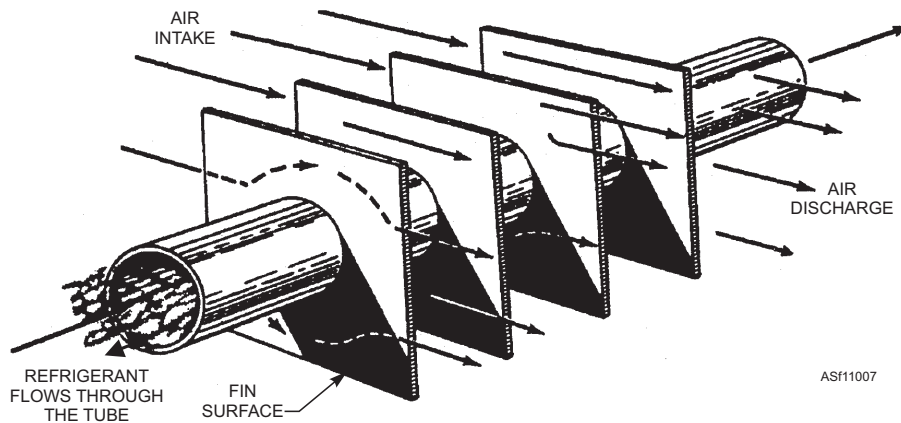

Figure 11-7.—Construction of an air-cooled condenser.

As the piston moves upward (view B of fig. 11-6), the pressure within the cylinder becomes greater than the pressure in the suction line. The intake valve closes. As the piston continues upward, the pressure within the cylinder continues to increase. When the pressure becomes greater than the pressure in the discharge line, the exhaust valve opens. The compressed refrigerant vapors discharge into the high-pressure side of the system.

A reciprocating compressor is lubricated by pressure from an oil pump or by splash as the crankshaft turns in the oil in the compressor crankcase.

CONDENSER

The purpose of the condenser (fig. 11-7) in a refrigeration system is to convert the hot refrigerant vapor from the compressor into a liquid state. The condenser removes heat from the hot vapor, causing it to condense at the pressure existing in the high-pressure side of the system. The condenser removes and dissipates the latent heat from the compressed gas to the surrounding air or water and transforms the refrigerant gas to a liquid.

The design of the condenser is determined by the cooling medium (usually air or water). The condenser may be made of coils of tubing with cooling fins on the outside, or coils of tubing (one tube inside another) with a coolant running through the inner tubing. The type of condenser used usually depends on the size of the unit. Air-cooled condensers are generally used on small units, and water-cooled condensers are normally used on large units. Air-cooled condensers are the type you will work on.

The air-cooled condenser uses a flow of ambient (surrounding) air across the coils of the condenser to provide a cooling effect. Maximum condenser surface

is obtained by closely spaced fins on the coils. The coil and fin arrangement is similar to that of an automobile radiator.

Maintenance of an air-cooled condenser used on a mobile air-conditioner is relatively minor, consisting of keeping the coil and fins free of dust and dirt. This should be done with care so as not to bend or damage the coil and fins.

RECEIVER

The purpose of the receiver (fig. 11-8) is to collect the liquid refrigerant as it leaves the condenser. It serves as a reservoir for the refrigerant and maintains a liquid seal on the liquid line to the expansion valve.

A receiver is designed to be large enough to hold the complete charge of refrigerant required for the unit to operate. It is equipped with shutoff valves on the inlet and outlet lines to permit maintenance personnel to pump the unit down (entrap all refrigerant in the receiver) when work is being done on another component of the system. With the shutoff valves closed, no loss of refrigerant occurs.

Due to the location of the inlet and outlet to the receiver, the receiver prevents the entrance of gaseous refrigerant into the liquid line. In most receivers there is a safety device to prevent excessive pressure buildup in the system. Some receivers are equipped with liquid

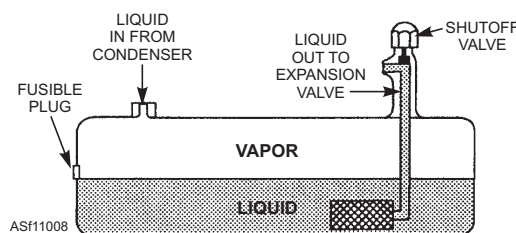

Figure 11-8.—Refrigerant receiver.

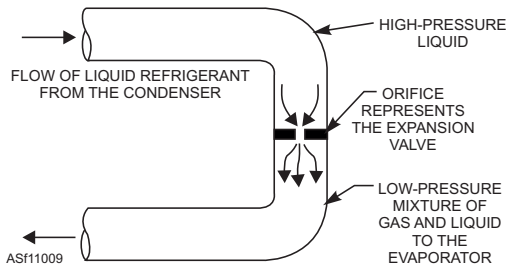

Figure 11-9.—Expansion valve principle.

sight glasses to show liquid level during operation. A receiver is normally about one-third full during operation.

HEAT EXCHANGER

The heat exchanger provides an increase in system efficiency by transferring heat from the hot liquid (flowing from the receiver to the evaporator) to the cooler suction vapor (flowing from the evaporator to the compressor). Because of this heat transfer, the liquid refrigerant enters the evaporator at a lower temperature, allowing it to absorb more heat per pound of refrigerant. This heat transfer also ensures that the vapor flowing to the compressor from the evaporator contains no liquid. Liquid entering the suction side will damage the compressor.

Heat exchangers can be constructed in several ways. Those you will encounter may be any of the following:

- A small liquid line enclosed within a larger suction line

- A small liquid line wrapped around a larger suction line
- A liquid line and suction line side by side and soldered together

EXPANSION VALVE

The expansion valve is a refrigerant metering device that is located between the high- and low-pressure sides of a refrigeration system to control the amount of liquid refrigerant that flows into the evaporator. There are other types of metering devices used in refrigeration systems, such as capillary tubes, but mobile air-conditioners use expansion valves.

The basic function of the expansion valve (fig. 11-9) is to change high-pressure liquid into low-pressure liquid as it enters the evaporator. The expansion valve, also referred to as a metering device, uses a combination of springs, bellows, a needle valve, and a thermostatic bulb (temperature-sensitive bulb) to control the refrigerant entering the evaporator. The liquid refrigerant flow is regulated as it is released into the evaporator to ensure maximum operating efficiency without overloading the compressor. The action of the valve is similar to a spray nozzle. It sprays a mist of refrigerant into the evaporator. This is the beginning of the low-pressure system.

The type of expansion valve used on mobile air-conditioners is called a *thermostatic expansion valve* (fig. 11-10). The valve meters the liquid refrigerant flow into the evaporator in proportion to the

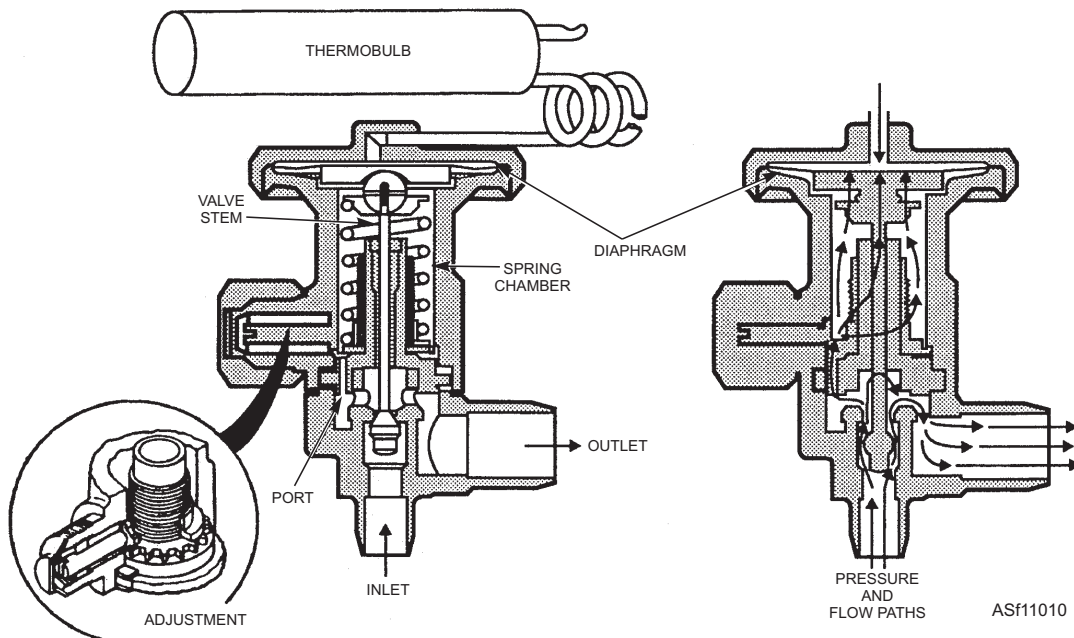

Figure 11-10.—Thermostatic expansion valve.

rate of expansion of the refrigerant. The rate of expansion of the liquid spray is dependent upon the rate of heat absorption from the air passing over the evaporator tubes. As the refrigerant spray changes to a vapor, it absorbs heat from the evaporator. The heat absorbed by the vapor is called *superheat*. By the time the refrigerant leaves the evaporator, all of it should be in superheated vapor form.

The metering valve is opened or closed by the action of the diaphragm at the top of the thermostatic valve. A thermobulb is attached to the diaphragm housing by a small tube. The bulb is filled with the same type of refrigerant used in the system. Heat felt by the thermobulb causes the refrigerant inside it to vaporize, which increases the pressure inside the bulb. The pressure is transmitted through the attaching tube to the diaphragm. The increased pressure on the diaphragm causes the metering valve to open. Opening the valve increases the refrigerant flow into the evaporator.

In figure 11-11, a thermostatic expansion valve is shown with the evaporator for a cooling unit operating at 37 psi suction (low-side) pressure. The refrigerant moving through the evaporator coil absorbs heat from the air outside the coil. At point B, it has absorbed sufficient latent heat for complete vaporization. At this point, all the liquid has vaporized. Any additional heat absorbed from the air raises the temperature of the vapor; but the pressure remains at 37 psi. This is the suction pressure of the compressor. By the time the vapor reaches the thermal bulb, point C, it has been

superheated according to the thermal expansion valve setting.

The temperature of the vapor in the middle of the coil is 40°F. By the time it reaches point C, it is 50°F. It has absorbed an additional 10°F of superheat. The thermobulb is mounted on the evaporator at the outlet to the compressor. The temperature within the bulb is the same as that of the evaporator at point C. The pressure within the thermal bulb, and consequently on the diaphragm within the thermal expansion valve, is 46.7 psi (P_1). This pressure tends to push the diaphragm down, opening the valve from the receiver. Opposing this force is the 37 psi (P_2) exerted against the bottom of the diaphragm by the vapor at the inlet of the evaporator coil. A spring pressure of 9.7 psi (P_3) added to 37 psi (P_2) holds the valve in equilibrium at 10°F superheat.

If an increase in load occurs, the superheat in the suction vapor increases, which causes the thermal bulb temperature and pressure to increase; a greater pressure on the top of the diaphragm is then exerted. This causes the valve to open further, allowing an increase in the flow of refrigerant to the evaporator to restore superheat to the 10-degree setting of the valve.

If a decrease in load occurs, the superheat decreases, and the pressure in the thermal bulb decreases. Evaporator inlet pressure plus spring pressure tends to close the valve, which reduces the flow of refrigerant sufficiently to maintain the superheat at 10°F.

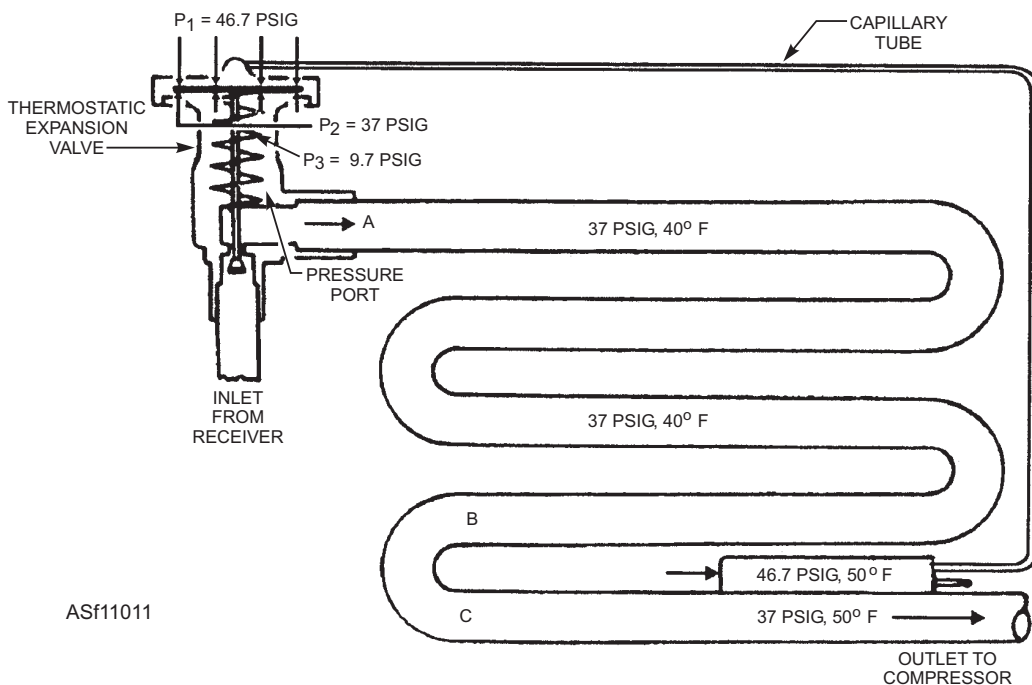

Figure 11-11.—Thermostatic expansion valve and evaporator.

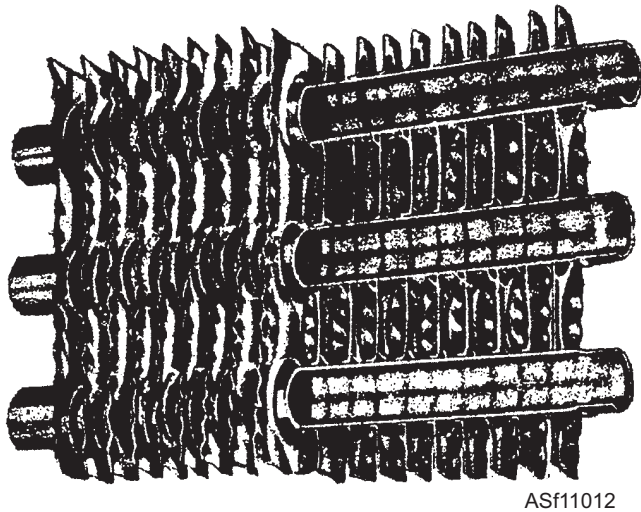

Figure 11-12.—Construction detail of an evaporator.

EVAPORATOR

The evaporator (fig. 11-12) is a band or coil of thin-walled tubing in a block of thin metallic fins. As the refrigerant is passed through the coil, warm air to be cooled is passed over the outside. Heat transfers from the outside air to the refrigerant through the fins and metal walls of the coil. The heat passing to the refrigerant causes it to vaporize. (Remember, R-22 vaporizes (boils) at -41°F .) And, as the refrigerant vaporizes, it cools the coil, which cools the warm air passing over it. The refrigerant exits the evaporator as a cool vapor at low pressure.

ACCESSORY COMPONENTS

There are various accessories that can be added to the major components to provide either simplified maintenance or increased efficiency without changing the function of the refrigeration system.

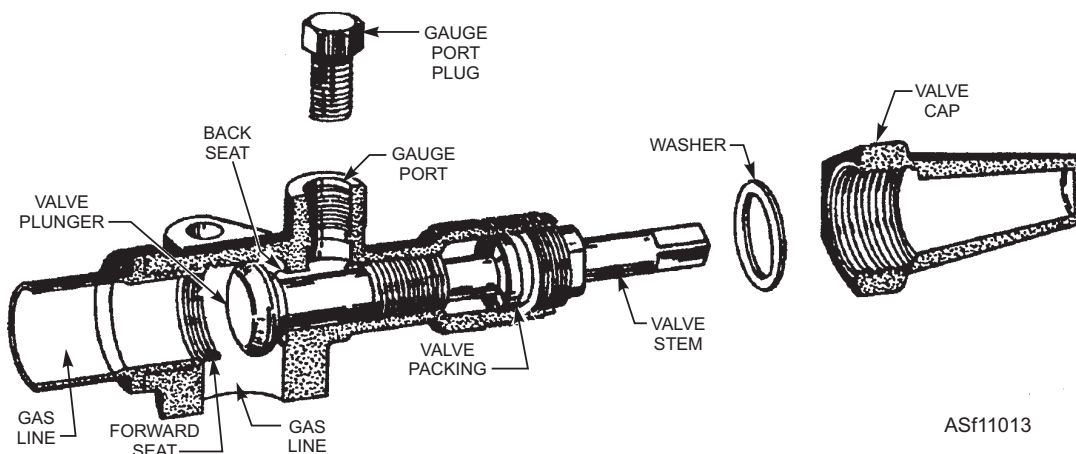

Figure 11-13.—Service valve.

Service Valves

Service valves (fig. 11-13), referred to as discharge (head) and suction valves, are provided for charging (filling) the system and for use during some maintenance operations. The discharge valve is mounted on the high-pressure port of the compressor; the suction valve is mounted on the low-pressure side. Construction of the valves and their method of operation are identical. However, they differ in size, use, and placement.

The service valves for the compressor and receiver have caps that must be removed prior to seating the valve. There are three “seating” positions: front-seated, back-seated, and mid-seated.

FRONT-SEATED.—When the valve is front-seated, all outlets are closed and refrigerant is trapped in the component (compressor or receiver). To front seat a service valve, turn the valve stem clockwise as far as it will go. This puts the valve stem to the left and tight against the front seat, and stops refrigerant flow at the valve.

WARNING

Never operate the compressor with the discharge service valve front-seated. This condition blocks the output of the compressor and causes its pressure to build up enough to become dangerous to personnel. Even if no explosion occurs, the compressor will almost certainly sustain damage.

BACK-SEATED.—The service valve is back-seated for normal operation. In this position, the refrigerant line to the system is completely open, and the servicing/gauge port is closed. To back seat a service valve, turn the valve stem counterclockwise as far as it will go.

NOTE: Use the back-seat position when installing a pressure gauge on the service valve.

MID-SEATED.—When the valve is mid-seated, both the system and servicing/gauge ports are open. This position is used during servicing or external monitoring. To mid seat a service valve, first back seat the valve, and then turn the valve stem one quarter turn clockwise. This moves the valve stem slightly to the left and allows gas to flow into the gauge port.

Vibration Eliminators

Vibration eliminators absorb and remove inherent vibration in copper tubing caused by floating components. They are constructed of an accordion-like phosphorous bronze tube with copper fittings at each end to facilitate joining with the system tubing. The accordion-like folds in the material are called *convolutions*.

On some air-conditioning systems, a simple loop is made in the refrigerant tubing itself. The loop permits vibrations to be absorbed in the extended length of tubing.

Liquid Line Sight Glass

The sight glass is a visual indicator used to visually determine the condition of the refrigerant entering the thermal expansion valve. The sight glass is located on the inlet side and as close to the thermal expansion valve as possible. The appearance of the refrigerant passing through the sight glass should be clear and free of bubbles. If the sighting indicates a cloudy or milky appearance, the level of refrigerant is low. The milky appearance is caused by tiny refrigerant vapor bubbles mixed with the liquid refrigerant.

Receiver Valve

The receiver outlet valve, referred to as the king valve or liquid line shutoff valve, is located on the output side of the receiver tank. This valve is used when it is necessary to trap the refrigerant in the receiver and condenser lines.

Drier-Strainer (Dehydrator)

The drier-strainer (fig. 11-14), also called a *dehydrator*, is used to remove foreign matter and water from the system. Foreign material can clog small openings, and water can freeze in the expansion valves, causing the system to malfunction. The drier-strainer is

located in the liquid line between the receiver and the evaporator. The refrigerant passes through a filter cloth, where foreign material is trapped; it then goes through a porous material of activated alumina or silica gel enclosed in a metal container, where moisture is absorbed from the system.

If the drier-strainer is frosted or feels cooler than the liquid line entering the drier, it indicates that the drier is clogged, and the liquid refrigerant is vaporizing in the drier. In this situation, the drier cartridge must be replaced.

Air Filter

The air filter is located in the inlet to the ventilation blower, and while technically not a component of the refrigeration system, it plays an important part in air conditioning. Filters are used to remove dust, bacteria, and odor from the air. The two types of filters in common use are the dry filter and the viscous filter.

The dry filter removes dirt by passing air through small openings in felt, spun glass, or paper screens. Some dry filters can be cleaned and reused, but most are disposable.

The viscous filter depends on dirt adhering to a surface covered with a viscous fluid or oil. When this type of filter gets dirty, it is cleaned, retreated with a viscous fluid or oil, and reused.

CONTROLS

Controls of an air-conditioning unit may be classed as two distinct types—operating and safety. Operating controls maintain the desired conditions. The safety

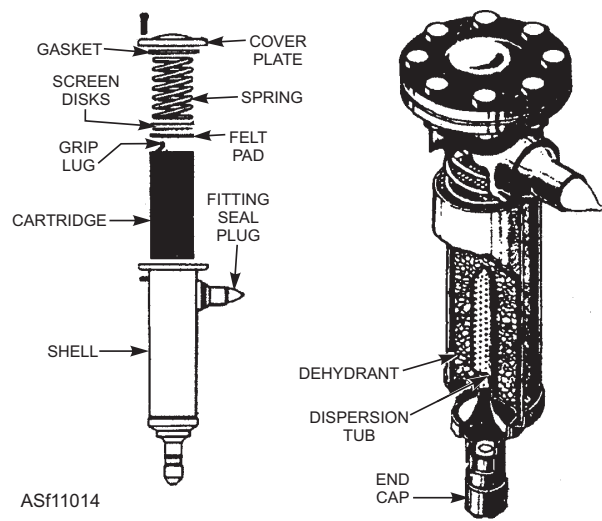

Figure 11-14.—Drier-strainer (dehydrator).

controls prevent damage to the equipment and injury to personnel.

Operating Controls

The operating controls of an air-conditioning system may be simple or complex, depending upon the design and use of the system. Some of the operating controls are manually controlled by the operator. Others are automatic and operate in response to changes in temperature or pressure.

THERMOSTAT.—A thermostat is a device that automatically regulates temperature. Thermostats used on mobile air-conditioners, similar to the one shown in figure 11-15, consist of a capillary tube filled with a volatile liquid, a bellows, and a set of electrical contacts.

The thermostat contacts are connected to a solenoid valve circuit. The capillary tube bulb is placed in the discharge airflow immediately downstream of the evaporator. As the temperature of the discharge air rises, the liquid in the capillary tube expands and exerts a pressure on the bellows. This causes the contacts to close, energizing the solenoid. The solenoid opens the valve so liquid refrigerant can flow to the expansion valve.

When the desired temperature of the discharge air is reached, a reverse of the above action occurs. The liquid in the capillary tube contracts, the contacts open, the solenoid valve closes, and the flow of refrigerant to the expansion valve is stopped.

SOLENOID VALVES.—Solenoid valves, similar to the one shown in figure 11-16, are used in mobile air-conditioners to control the flow of refrigerant at various points in the system. These valves are of two types—normally opened or normally closed. Regardless of type or use, construction and function of the valves are essentially the same.

In the normally closed type, when the circuit to the solenoid coil is completed, the coil energizes and pulls the valve off its seat, opening the valve passage. When the circuit to the solenoid coil opens, the coil de-energizes and spring pressure pushes the valve into its seat, closing the valve passage.

Operation of the normally opened type is the reverse of the operation of the normally closed type. When the solenoid coil energizes, the valve closes; when the solenoid coil de-energizes, the valve opens.

CIRCUIT CONTROLS.—Controls for the various circuits of an air-conditioning unit may vary from a simple toggle switch to remote-controlled contact relays. These devices may be used for actuating fans, lights, motors, or for checking various circuits while troubleshooting a defective system. Switches used for maintenance work are called *service switches*.

Safety Controls

Safety devices are installed in air-conditioning systems to prevent bodily injury to operating personnel and damage to equipment and spaces receiving the conditioned air.

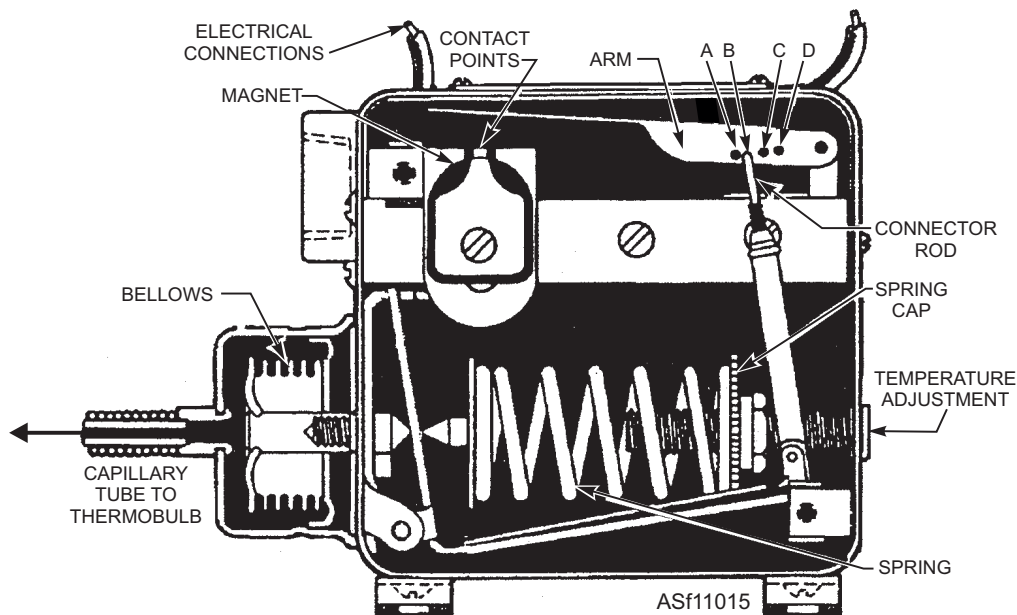

Figure 11-15.—Thermostat.

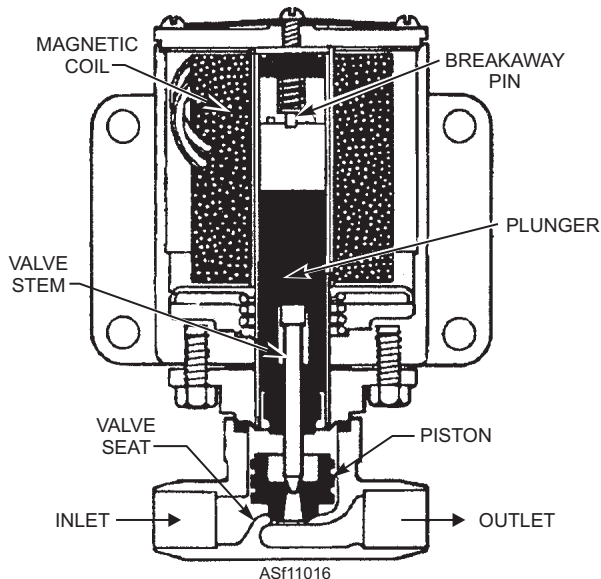

Figure 11-16.—Solenoid valve.

FUSIBLE PLUG.—The fusible plug is provided to prevent excessive buildup of refrigerant pressure within the confined area of the equipment. The refrigerants commonly used today act in accordance with normal liquid/gas laws; that is, increased temperature causes increased pressure. Should the air-conditioning equipment be in close proximity to a fire, a positive method of releasing vapor and liquid must be provided to prevent the buildup of excessive pressure within the system. The fusible plug is commonly used for this purpose. The fusible plug is usually threaded into the receiver tank. (See figure 11-8.) When excessive external heat is present, due to fire or other similar causes, the plug melts, allowing the refrigerant gas to escape from the system. The reduction of gas pressure prevents possible rupture or explosion of the equipment. Extreme caution must be exercised if this situation occurs.

WARNING

When refrigerant R-22 comes in contact with a flame, phosgene gas forms. Phosgene gas is a deadly nerve gas. Whenever you work with this refrigerant, the working space must be thoroughly ventilated.

HIGH-PRESSURE RELIEF VALVE.—A high-pressure relief valve that functions similar to a fusible plug may be installed in the receiver. When the pressure in the receiver increases above a preset value, the relief valve opens, venting excess pressure. Unlike the fusible plug, however, after the pressure reaches a

safe level, the relief valve reseals and stops venting refrigerant.

HIGH- AND LOW-PRESSURE CUTOUTS.—

High- and low-pressure cutout switches are incorporated in refrigeration units to control the operation of the compressor. The controls prevent the discharge pressure of the compressor from building up beyond a reasonable limit and the suction pressure of the compressor from falling below the safe limit.

The control unit, illustrated in figure 11-17, contains controls for both the high- and low-pressure gases. In some installations the high- and low-pressure controls are mounted in separate units; however, their operation is essentially the same.

CURRENT LIMITERS.—Current limiters are usually fuses or circuit breakers. They are used in electrical circuits to prevent the current from going beyond reasonable limits in the event of a malfunction, such as shorted or grounded circuits. The current limiters open and interrupt the circuit current if their rated current is exceeded for a short period of time. The exact amount of time the current limiter will carry the excessive current depends upon the type and rating of the current limiter and the amount of overload.

DUCT AIR PRESSURE SWITCH.—The duct air pressure switch is designed to shut down the entire unit if an overpressure condition occurs in the conditioned air discharge duct. The pickup tube for the

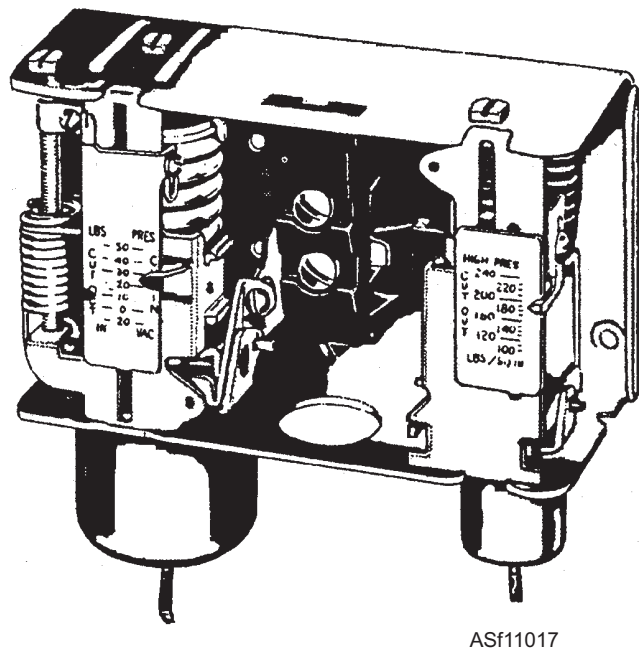

Figure 11-17.—High- and low-pressure safety control cutouts.

duct pressure switch is located in the discharge air plenum chamber.

Q11-12. Which of the following statements best describes the function of the compressor in an air-conditioning system?

- 1. It receives low-pressure refrigerant vapor from the condenser and compresses it to such an extent that it liquefies in the evaporator*
- 2. It receives low-pressure refrigerant vapor from the evaporator and compresses it to such an extent that it liquefies in the condenser*
- 3. It receives low-pressure liquid from the receiver and circulates it throughout the system*
- 4. It receives low-pressure liquid from the expansion valve and circulates it to the evaporator*

Q11-13. Which of the following components will entrap the liquid refrigerant during the pump down cycle?

- 1. The evaporator*
- 2. The condenser*
- 3. The piping*
- 4. The receiver*

Q11-14. Which of the following components is located between the high-pressure side and the low-pressure side of the system and meters the amount of refrigerant that flows into the evaporator?

- 1. The expansion valve*
- 2. The heat exchanger*
- 3. The flow control valve*
- 4. The regulator*

Q11-15. What part of the expansion valve is attached to the diaphragm housing by a small tube?

- 1. The thermometer*
- 2. The metering bulb*
- 3. The thermobulb*
- 4. The pressure regulator*

Q11-16. What is the state of the refrigerant when it exits the evaporator?

- 1. A hot vapor at low pressure*
- 2. A cool vapor at low pressure*
- 3. A super-heated vapor at high pressure*
- 4. A super-heated vapor at low pressure*

Q11-17. When the liquid line sight glass has a cloudy or milky appearance, it is an indication that which of the following conditions exists?

- 1. That water is present in the system*
- 2. The system pressure is too high*
- 3. The refrigerant is dirty and needs to be replaced*
- 4. The level of refrigerant is low*

Q11-18. Where would you find a fusible plug in an air-conditioning system?

- 1. In the receiver*
- 2. In the pump*
- 3. In the liquid line*
- 4. In the expansion valve*

Q11-19. What is the purpose of the high- and low-pressure cutouts in an air-conditioning system?

- 1. To protect the condenser from low inlet pressure and excessive discharge pressure*
- 2. To protect the evaporator from low inlet pressure and excessive discharge pressure*
- 3. To protect the compressor from low inlet pressure and excessive discharge pressure*
- 4. To protect the receiver from low inlet pressure and excessive discharge pressure*

A/M32C-17 TRAILER-MOUNTED AIR-CONDITIONING UNIT

LEARNING OBJECTIVES: Identify procedures for inspecting, checking, testing, and adjusting air-conditioner components. Identify procedures for troubleshooting and repairing air-conditioner components.

There are two primary mobile air-conditioners in use in the fleet today, the A/M32C-17 and the A/M32C-21. The A/M32C-21 (fig. 11-18) is electric-powered and is used both ashore and afloat. The A/M32C-17 (fig. 11-19) is diesel-powered and is used ashore only. The units are similar in many ways, so we have chosen to focus primarily on the A/M32C-17 in this course. For information on the A/M32C-21, see AG-180AO-MMM-000.

The A/M32C-17 is a mobile self-contained unit that consists primarily of a diesel engine drive system, refrigeration system, ventilating system, hydraulic system, and control system. This unit is enclosed in a trailer-mounted metal housing. The trailer is suitable for towing behind a military vehicle.

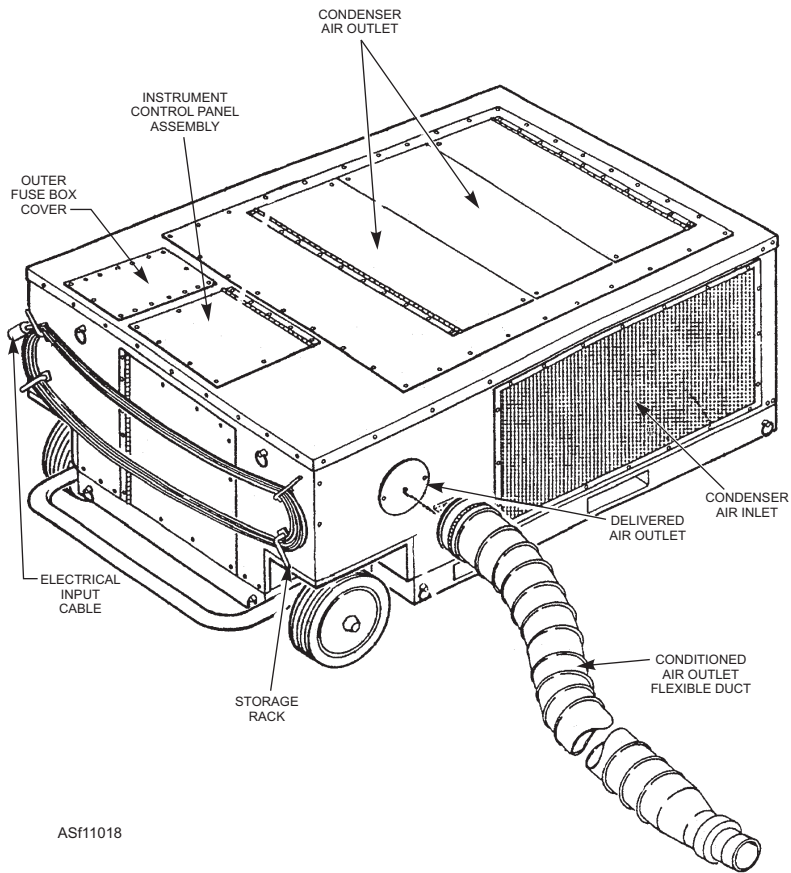

ASf11018

Figure 11-18.—A/M32C-21 trailer-mounted air-conditioning unit, electric-powered.

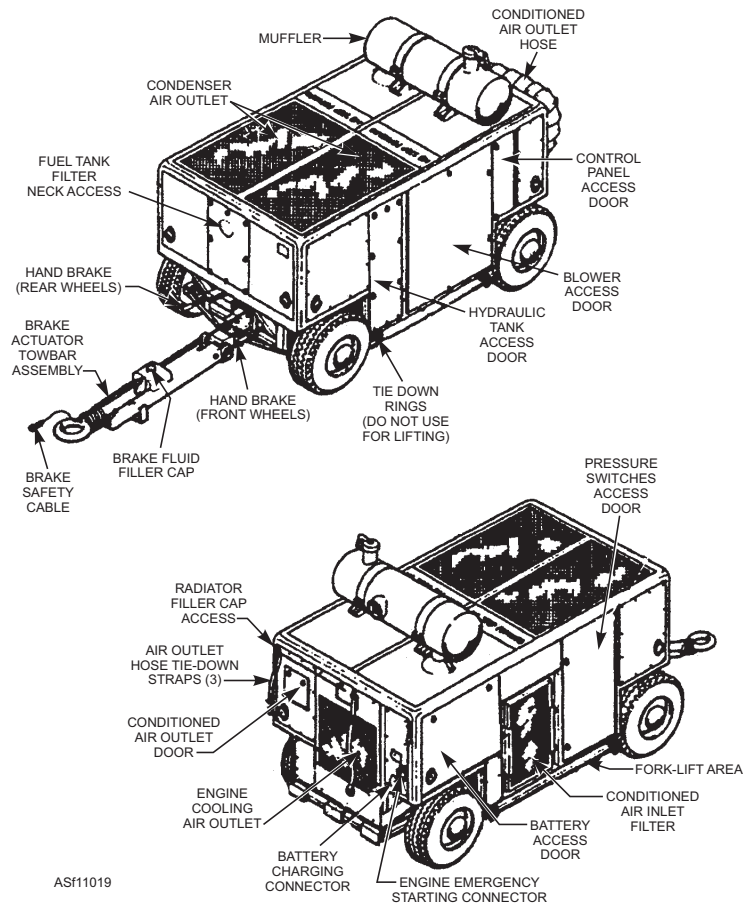

ASf11019

Figure 11-19.—A/M32C-17 trailer-mounted air-conditioning unit, diesel-powered.

The A/M32C-17 air conditioner is designed to operate at an ambient temperature range from 0°F to 110°F dry bulb and 85°F wet bulb. It is capable of being stored at -65°F without adverse effect.

The unit can operate at pressure altitudes from sea level to 5,000 feet. It is capable of delivering 150 pounds per minute of refrigerated air, ventilating air, or hot dehumidified air at static pressures up to 2 psi 30 feet from an 8-inch diameter insulated flexible duct. It can also deliver 75 pounds per minute of air at static pressures up to 4 psi at the end of the delivery hose. The unit is capable of operating as a ventilating blower

(without refrigeration of ambient temperatures) throughout the ambient temperature range.

The unit operates as a refrigeration system, delivering air temperature at 45°F ±5° with a maximum relative humidity of 80 percent with no entrained water at the coupling end of the delivery hose. The unit is capable of operating as a dehumidifier at ambient temperatures ranging from 40°F to 110°F dry bulb and 85°F wet bulb. Delivery air is supplied at a temperature of at least 90°F. The dew point of the delivery air will not exceed 40°F throughout the ambient temperature range from 40°F to 110°F dry bulb or 85°F wet bulb.

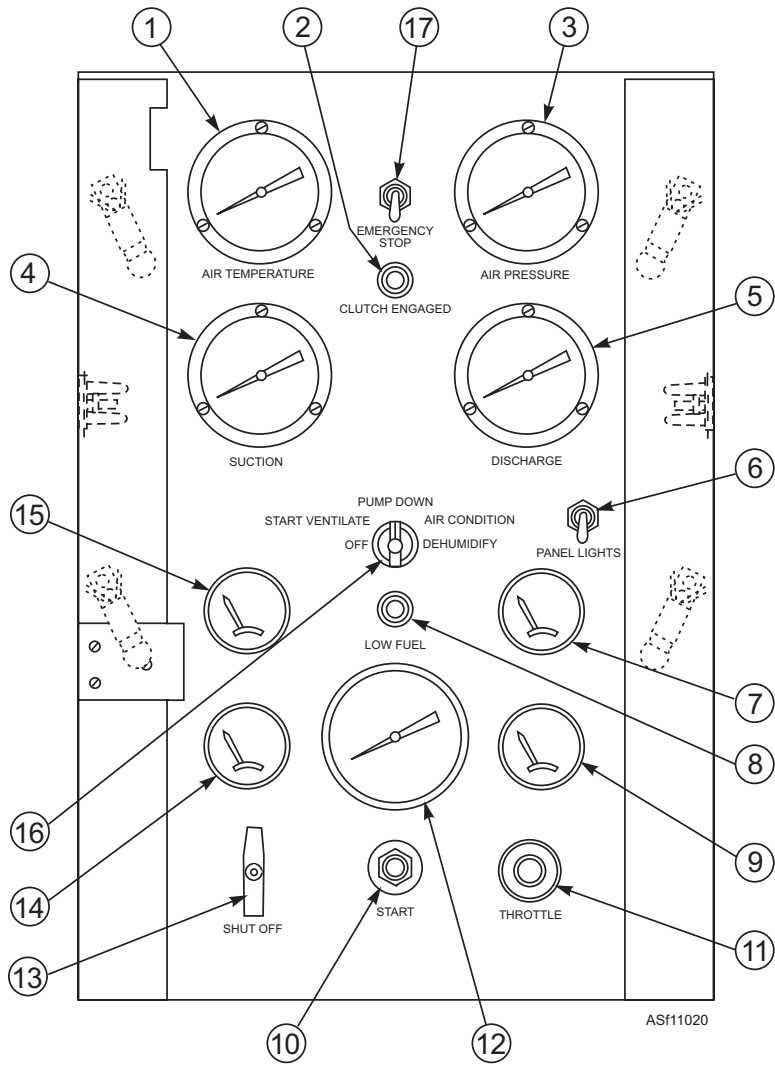

- | | |
|--|---|
| 1. OUTLET AIR TEMPERATURE GAUGE | 10. STARTER SWITCH |
| 2. CLUTCH INDICATOR LIGHT | 11. ENGINE SPEED THROTTLE |
| 3. OUTLET AIR PRESSURE GAUGE | 12. TACHOMETER AND OPERATING TIME METER |
| 4. COMPRESSOR SUCTION GAUGE | 13. FUEL SHUTOFF |
| 5. COMPRESSOR DISCHARGE PRESSURE GAUGE | 14. ENGINE OIL PRESSURE GAUGE |
| 6. PANEL LIGHT SWITCH | 15. VOLTMETER |
| 7. FUEL LEVEL GAUGE (LARGE TANK) | 16. SELECTOR SWITCH |
| 8. FUEL WARNING LIGHT | 17. EMERGENCY STOP (NOT ON UNITS WITH HKQ SERIAL NUMBERS) |
| 9. ENGINE COOLANT TEMPERATURE GAUGE | |

Figure 11-20.—A/M32C-17 control panel.

OPERATING CONTROLS

The operating controls are mounted on the control panel (fig. 11-20). The thermostats, pressure controls, and switches are mounted inside the housing near the devices they control. The functions of the controls and indicators are listed in table 11-3.

MODES OF OPERATION

The air-conditioner can ventilate, cool, or dehumidify the area to be conditioned, as determined by the setting of the selector switch. (See figure 11-20.)

The principles of operation of these functions are described separately. Each of the descriptions is written with the assumption that the engine is operating and functioning normally.

Cool Mode (Air Conditioning)

Moving the selector switch to the AIR CONDITION position starts the refrigeration cycle. As you learned earlier, the refrigeration cycle is based upon the principle that liquid refrigerant becomes cold as its pressure is reduced, absorbs heat as it expands to a vapor, becomes a warm gas when compressed, and

Table 11-3.—A/M32C-17 Controls and Indicators

Nomenclature	Function/Indication	Normal Position Range/Setting
1. Outlet air temperature	Indicates outlet air temperature	As desired
2. Clutch indicator light	Light ON indicates clutch engaged	ON-OFF
3. Outlet air pressure	Indicates outlet air pressure	1 to 4.5 psi
4. Compressor suction pressure	Indicates compressor suction	48 to 65 psi
5. Compressor discharge pressure	Indicates compressor head pressure	100 to 365 psi
6. Panel light switch	Illuminates control panel	ON-OFF
7. Fuel level gauge	Indicates fuel level in large tank	FULL to EMPTY
8. Fuel warning light	Indicates large fuel tank is empty; small fuel tank is low	ON-OFF
9. Engine coolant	Indicates engine temperature	About 180°F
10. Starter switch	Rotates engine to start	Momentary ON
11. Throttle	Controls engine speed (rpm)	(See Tachometer)
12. Tachometer and operating-time meter	Indicates engine speed (rpm) and elapsed operating time	550 rpm (idle) 2000 rpm (normal)
13. Fuel shutoff	Cuts off fuel supply to engine	ON-OFF
14. Oil pressure gauge	Indicates engine oil pressure	30 to 60 psi
15. Voltmeter	Indicates operation of alternator and battery condition	Variable
16. Selector switch	Selects operating modes	As desired
17. Emergency stop switch (not on units with HKQ serial numbers)	Stops unit in emergency situations without allowing for engine cooling or refrigeration pump down	Place in UP position to stop unit

gives up heat to return to a liquid. Refer to figure 11-21 as you study the refrigeration cycle of the A/M32C-17.

The compressor (1) converts low-pressure gas (R-22) from the three evaporators (14, 15A, 15B) into high-pressure gas. This hot, high-pressure gas is then passed into the condenser coil (4A, 4B).

The hot high-pressure gas is cooled by the condenser airflow and condensed into high-pressure liquid. The liquid then passes to and is stored in the receiver tank (5).

The liquid refrigerant passes from the receiver tank (5) through the drier-strainer (10), subcooler (heat exchanger) (9), solenoid valves (27, 28), and sight glasses (11A, 11B). A portion of the liquid is passed through an expansion valve (26) and is circulated through the subcooler (9) to aid in the cooling of the liquid refrigerant.

The subcooled liquid refrigerant is metered by the expansion valves (12A, 12B, 13, 32). These valves meter the refrigerant flow and reduce the pressure of the refrigerant so that the liquid refrigerant enters the three evaporators (14, 15A, 15B) as a cold low-pressure mixture of liquid and vapor.

The cold, low-pressure mixture of liquid and vapor absorbs heat from the air passing over and through the three evaporator coils. In the process of absorbing the heat, the refrigerant evaporates to a low-pressure gas. The low-pressure gas is drawn to the suction side of the compressor (1) where the refrigeration cycle starts over.

The aftercooler evaporator coils (15A, 15B) each have a thermostat-controlled solenoid valve (27, 28). These solenoid valves open and close depending upon air temperature at the outlet of the unit. Output air temperature is controlled by the opening or closing of one, or both, aftercooler solenoid valves. The thermostat bulb for the aftercooler evaporators is located at the air outlet to the conditioned area.

The A/M32C-17 has a hot gas bypass system to permit recirculation of compressor discharge gas. This system automatically induces an artificial load to match the evaporator's load. When the hot gas pilot valve (30) senses that the suction pressure has dropped below a preset point, it opens the hot gas pressure regulator (31) to permit hot gas to bypass the compressor. A quench

valve (33) is installed in the line to permit cold liquid refrigerant to be added to the hot gas to lower the temperature of the hot gas. A hot gas solenoid valve (29) is installed in the line to allow the unit to "pump down" when the cooling system is turned off.

In addition to the hot gas bypass system, the compressor is equipped with automatic internal unloaders. An unloader is a device that causes the compressor's internal suction valves to be lifted from their seats, which allows equalizing high-side and low-side pressures for a brief time during starting, and for controlling compressor capacity. As more refrigerant is demanded, this unloading process is reversed until the compressor is delivering its maximum output.

Ventilate Mode

Since the ventilating blower is belt-driven directly from the engine drive shaft on the input side of the clutch, the blower operates whenever the engine operates. When the selector switch is moved to START-VENTILATE, the ventilating blower draws ambient outside air through the inlet air filter and blows the air into the conditioned area. A damper inside the housing in the air inlet plenum provides a means of airflow control.

Dehumidify Mode

Moving the selector switch to the DEHUMIDIFY position starts the refrigeration cycle. Running in the dehumidify mode, however, the unit uses only the precool evaporator. The air is cooled enough to reduce its moisture content, and then warmed during its movement through the blower.

Pump Down Mode

The pump down function is used to shut down the refrigeration cycle prior to securing the air-conditioner or at any time the system must be opened. When the selector switch is in the PUMP DOWN position, the three evaporator solenoids close, and the system continues to pump the refrigerant into the receiver until the low-pressure cutout stops the compressor. At that point, most of the refrigerant is contained in the receiver.

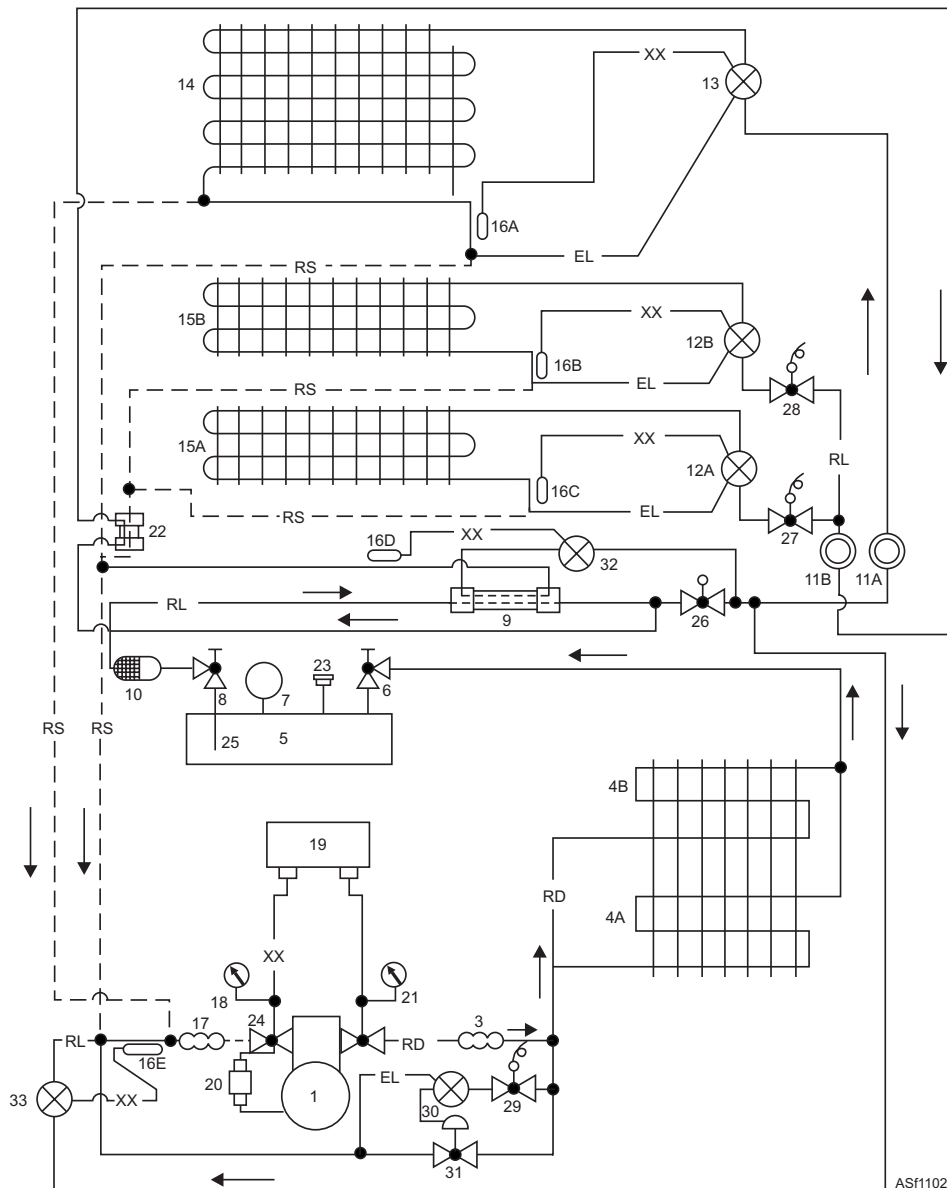

- | | | |
|--|---|---------------------------------------|
| 1. Compressor | 14. Precooler coil | 23. Fusible plug |
| 2. Compressor discharge service valve | 15A. Aftercooler evaporator coils (single housing, two stage) | 24. Compressor suction service valve |
| 3. Vibration absorber | 15B. Aftercooler evaporator coils (single housing, two stage) | 25. Quill receiver outlet |
| 4. Condenser coil (single housing two stage) | 16A. Thermal bulb | 26. Precooler solenoid valve |
| 5. Receiver | 16B. Thermal bulb | 27. Aftercooler solenoid valve |
| 6. Receiver inlet service valve | 16C. Thermal bulb | 28. Aftercooler solenoid valve |
| 7. Pressure-relief valve | 16D. Thermal bulb | 29. Hot gas bypass solenoid valve |
| 8. Receiver outlet service valve | 16E. Thermal bulb | 30. Hot gas bypass pilot valve |
| 9. Subcooler (heat exchanger) | 17. Vibration absorber | 31. Hot gas bypass pressure regulator |
| 10. Drier-strainer | 18. Suction stage | 32. Expansion valve |
| 11A. Liquid indicator (sight glass) | 19. High-low pressure cutout | 33. Expansion valve liquid quench |
| 11B. Liquid indicator (sight glass) | 20. Low compressor oil cutout | RD. Refrigerant discharge line |
| 12A. Aftercooler expansion valve | 21. Discharge pressure gauge | RL. Refrigerant liquid line |
| 12B. Aftercooler expansion valve | 22. Heat exchanger | RS. Refrigerant suction line |
| 13. Precooler expansion valve | | EL. Equalizer line |
| | | XX. Sensing lines, thermal bulbs |

Figure 11-21.—A/M32C-17 refrigeration diagram.

HYDRAULIC SYSTEM

In the hydraulic system of the A/M32C-17 (fig. 11-22), the hydraulic pump is belt-driven from the electrical clutch. The pump draws fluid from the reservoir and pumps it through the relief valve to the fan motor and to the remote control valve. It returns the fluid to the reservoir through the oil cooler and oil filter.

The pressure transducer has a capillary line connected in the refrigerant line to sense refrigerant head pressure. If the refrigerant head pressure is high, the pressure transducer closes the remote pressure control valve to permit the motor to operate at a relatively high speed. If the refrigerant head pressure is low, the pressure transducer opens the remote pressure control valve to allow the fluid to pass through the remote control valve to the oil cooler, oil filter, and reservoir. This action results in the motor slowing down, reducing the amount of airflow through the condenser. This causes an increase in pressure on the high side of the system.

MAINTENANCE

The A/M32C-17 is a heavy-duty, well constructed air-conditioning unit. But, like other equipment, it requires regular servicing and inspections to maintain peak performance. It is beyond the scope of this text to cover all of the related maintenance procedures; therefore, only general procedures are discussed briefly in the following text. This will include information on servicing, troubleshooting, and repair. Applicable

safety precautions and first-aid information are also included.

On the job, use the maintenance requirements cards (MRCs) for the A/M32C-17 as your primary reference when inspecting and servicing the unit. However, as the MRCs contain only the minimum requirements, for more detail, refer to the technical manual *Organizational, Intermediate, and Depot Maintenance with Illustrated Parts Breakdown, Mobile Air Conditioning Unit, Model A/M32C-17*, NAVAIR 19-60-87.

NOTE: If there is a conflict between information in NAVAIR 19-60-87 and the MRCs, the MRCs take precedence.

Prior to working on an air-conditioning refrigeration system that involves the possibility of release of refrigerant into the atmosphere, you must be certified and meet the requirements of the United States Environmental Protection Agency's (EPA) certification requirements for universal technicians, as required by EPA Regulation 40 CFR, Part 82, Subpart F. This certification does not ensure that you are a trained air-conditioner technician, but it does ensure that you are fully aware of the laws, rules, and regulations required to service the three types of systems, as well as the common core issues.

Refrigeration Servicing Equipment

Repair and service work on refrigeration systems involves two major considerations—containing the

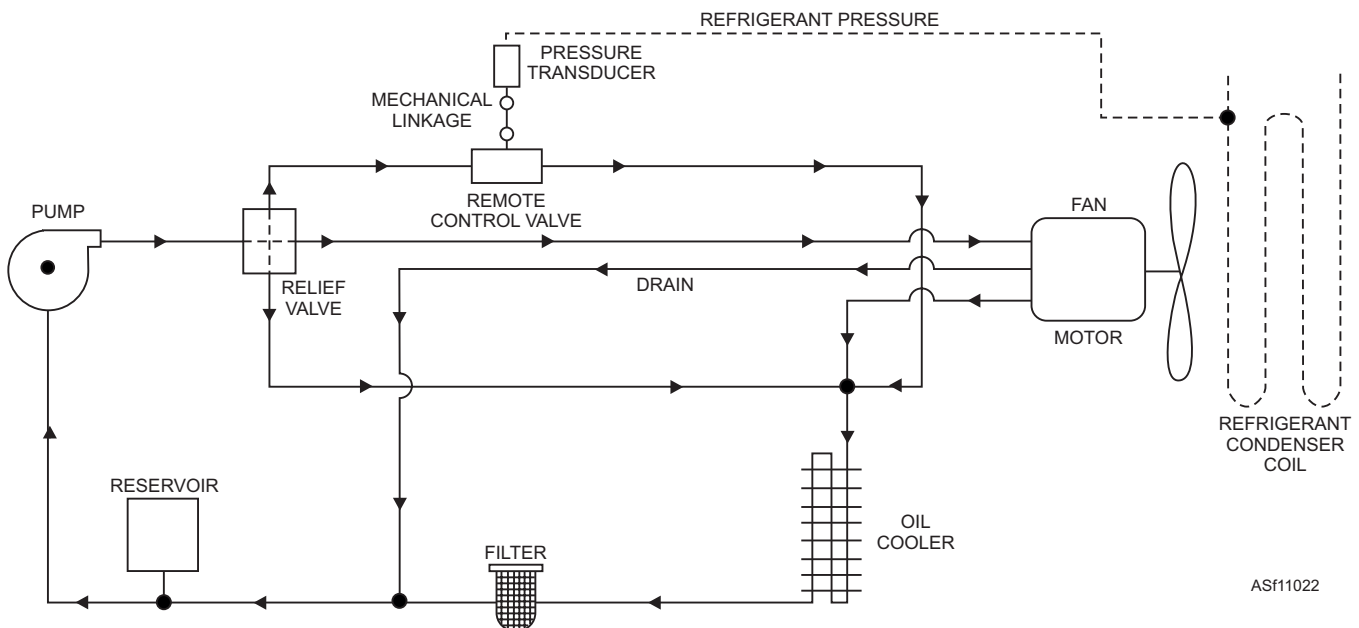

Figure 11-22.—Hydraulic system.

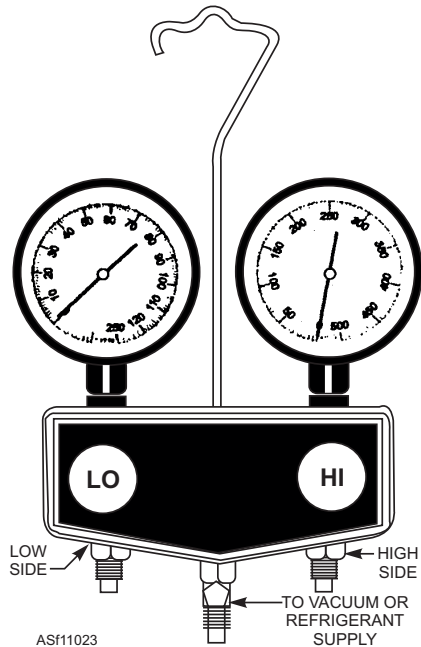

Figure 11-23.—Refrigerant manifold test set.

refrigerant and accurately measuring pressures. If the refrigerant cannot be contained within the system, the system will not operate due to low-pressure safety devices. Or, if the high pressure (discharge) or the low pressure (suction) is not within normal operating ranges, correct cooling temperatures will not be achievable.

REFRIGERANT MANIFOLD TEST SET.—

One piece of equipment designed to measure pressure is the refrigerant manifold test set (fig. 11-23). The test set consists of a 0 to 500 psi gauge for measuring

pressure at the compressor high side, a compound gauge (0 to 250 psi and 0 to -30 inches of mercury) to measure the low or suction side, valves to control admission of these pressures to the gauges, and the connections and lines required to connect the test set to the system. Depending on test and service requirements, the test set can be connected to the low side, the high side, a source of vacuum, a refrigerant cylinder, or a refrigerant-recovery system. A swiveling hanger allows you to hang the test set for easy access, and three additional blank connections, not shown in the figure, allow for securing the open ends of the three lines when the test set is not in use.

There is always a path from the low-side input to the low-side gauge and from the high-side input to the high-side gauge (fig. 11-24). Two valves control the path of the refrigerant supply input. If the LO valve is open, the refrigerant supply input has a clear path to the low-side gauge and the low-side input. If only the HI valve is open, the refrigerant supply input has a clear path to the high-side gauge and the high-side input. The hose in the center can be connected to a vacuum pump, a recovery-recycle system, or a refrigerant supply cylinder, depending on the type of servicing you wish to perform.

PORTABLE VACUUM PUMP.—Another important piece of equipment you will use is the portable vacuum pump. The type discussed here will be a single piston vacuum pump driven by an electric motor. A vacuum pump is the same as a compressor except that the valves are arranged so that the suction valve is

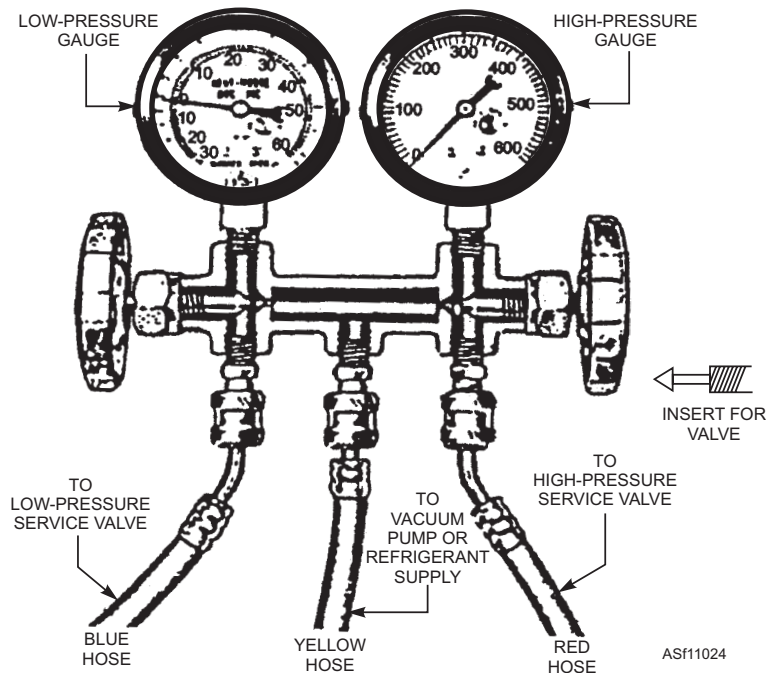

Figure 11-24.—Internal view of refrigerant manifold test set.

opened only when the suction developed by the downward stroke of the piston is greater than the vacuum already in the line. This vacuum pump can develop a vacuum close to -30 inches of mercury, which can be read on the gauge mounted on the unit (fig. 11-25). You will use the pump when it is necessary to remove air and moisture from the system, a process called *evacuation*.

Evacuating the System

Evacuation is required to remove all traces of moisture that may have entered the system during maintenance. Moisture turns into vapor under a vacuum and must be removed from the system to prevent freezing of expansion valves and blocking of passageways. Moisture also contributes to the formation of hydrochloric and hydrofluoric acids in the system, which can cause corrosion and gumming of internal parts of compressors and piping.

Whenever the system is opened, precautions must be taken to prevent loss of refrigerant to the atmosphere. There are two ways to contain the refrigerant (gas and liquid). One way is to trap the refrigerant in the receiver (pumping down). The other way is to remove it from the system by using a refrigerant recovery unit, which removes the refrigerant from the mobile air conditioner and stores it in external tanks.

PUMPING DOWN.—The first step in evacuating the system is to pump it down by using the following procedures:

1. Close (front seat) the receiver outlet valve.

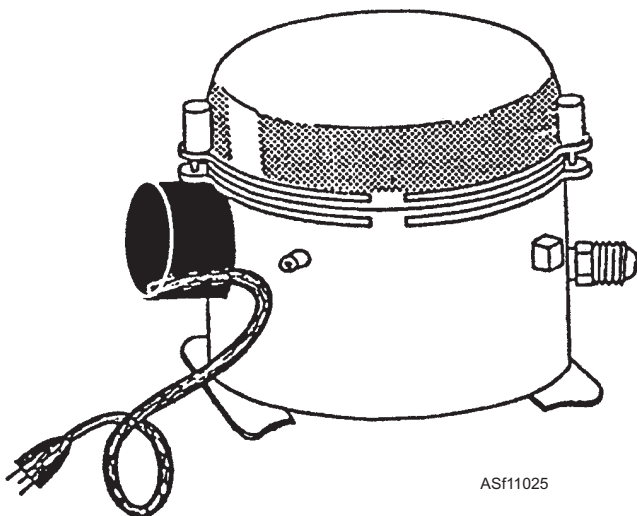

Figure 11-25.—Portable vacuum pump.

2. Set the operating mode (selector valve) to PUMP DOWN. (See figure 11-20.)

3. Set the thermostats to the coldest temperature possible to hold the evaporator coils open.

4. Disconnect the ground wire of the hot gas bypass valve. This de-energizes the valve to prevent bypassing during pump down.

5. Place a jumper wire on the contacts of the low-pressure relay. Doing so cuts the relay out of the circuit and keeps the compressor running during the procedure.

6. Monitor the suction gauge until it reads 5 psi. At 5 psi, turn the selection valve to the start-ventilate position. This disengages the compressor.

7. Continue to monitor the suction gauge. It will normally rise above 5 psi due to the refrigerant still in the system. Repeat the pump down procedure until the system stabilizes at a maximum of 5 psi, but no lower than 2 psi.

8. When the system is stabilized at 2 to 5 psi, shut down the engine.

9. Close (front seat) the compressor discharge valve.

10. Close (front seat) the receiver inlet valve.

11. Close (front seat) the compressor suction valve.

12. Remove the jumper wire from the low-pressure relay.

13. Reset the thermostats back to their normal operating positions.

That completes the pumping down part of the procedure. This part of the procedure could be performed by using a refrigerant recovery unit to transfer the refrigerant to an external tank.

EVACUATING.—After the system has been pumped down and the refrigerant is trapped in the receiver, you can evacuate the system by using the following procedures:

1. Connect the refrigerant manifold test set, as shown in figure 11-26.

2. Ensure that the receiver inlet and outlet valves are closed (back seated).

3. Ensure that the compressor suction and discharge valves are closed to the service port (back seated).

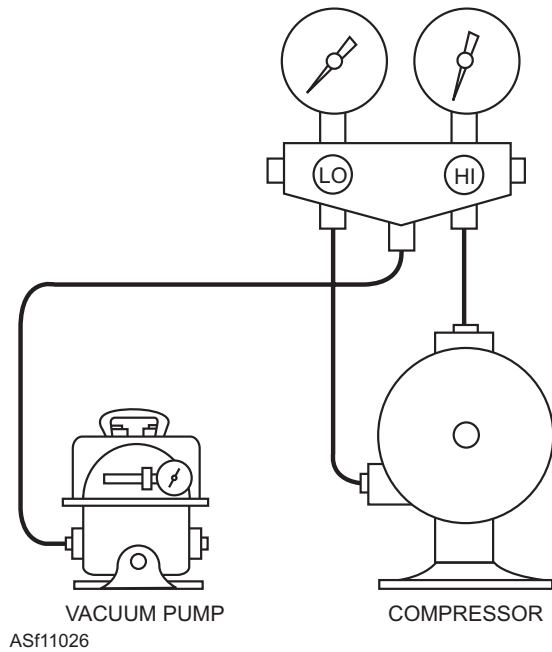

Figure 11-26.—Connections for drawing a vacuum.

4. Tighten the gland nuts of the manifold gauge set at the manifold and at the compressor suction and discharge ports.
 5. Open the compressor suction and discharge valves by turning them clockwise one to two turns (mid seat) from the back seated position.
 6. Plug in the vacuum pump, and turn it on.
 7. Monitor the gauge set to ensure that a vacuum of no more than 2.5 mmHg, absolute, registers on the gauge. The length of time to reach this reading will vary, depending upon the amount of moisture in the system and the efficiency of your vacuum pump.
 8. After the system has been evacuated, attach a source of dry nitrogen to the liquid charging line.
 9. Slowly break the vacuum with the dry nitrogen to a maximum of 300 psi, as read on the high-pressure gauge on the control panel and on the regulator of the nitrogen cylinder.
- NOTE:** Check your technical manual to confirm the correct pressure for your system.
10. Repeat steps 6 and 7. This double evacuation should remove all traces of water vapor from the system.
 11. Let the system stand, under vacuum, for at least 1 hour. If no noticeable rise in pressure has taken place after 1 hour, the system is ready for charging.

Component Removal and Replacement

The first step in the removal of any component in a refrigeration system for repair and/or replacement is to pump down the system. As you have learned, this procedure traps practically all of the refrigerant in the condenser and receiver and, by the proper positioning of the valves, the evaporator, expansion valve, and compressor (with connecting lines) can be removed with a minimum loss of refrigerant.

REMOVING EXPANSION OR FLOAT VALVES.—To help ensure good results when removing expansion or float valves, pump the system down to a suction pressure of just over zero. Then, remove the expansion valve, and plug the opened end of the liquid line and evaporator coil to prevent air from entering the system. Repair or replace the expansion valve, and connect it to the liquid valve. Crack the receiver service valve to purge air from the liquid line and the expansion valve. Connect the expansion valve to the evaporator coil inlet and tighten the connection. Pump a vacuum into the low side of the system to remove any air and moisture.

REMOVING THE EVAPORATOR.—When it is necessary to replace an evaporator, pump down the system and disconnect the liquid and suction lines. Then, remove the expansion valve and the evaporator. After making the necessary repairs, reinstall the evaporator. Replace the expansion valve, and connect the liquid and suction lines. Remove moisture and air by pumping a deep vacuum in the system. Check for leaks and correct them, if found. After fixing any leaks, pump a deep vacuum again. Repeat the process until no more leaks are found.

REMOVING THE COMPRESSOR.—As was the case in removing the evaporator, the first step in removing the compressor is to pump down the system. To remove it from service, the compressor must first be isolated by closing the suction and discharge service valves. Then, pressure within the compressor must be equalized. Both suction pressure in the crankcase and head pressure can be equalized to atmospheric pressure by either positioning the service valves to the vent position or cracking the connections to the compressor. When the lines to the compressor are disconnected, be certain to cover or block them to prevent dirt and moisture from entering them until the compressor can be reinstalled. After reinstalling the compressor, the air must be evacuated by drawing a vacuum on the system. Then, the system must be recharged.

Adjustments

The adjustments of the many valves and solenoids have one thing in common—they are very sensitive and only one turn, or two at the most, is all that is required at a time. Then, the system has to run for a while until all readings stabilize. With this in mind, you can see that consulting the manual (with all of its tables of normal settings and relationship charts) is a necessity when performing maintenance on an air-conditioning system.

Superheat is adjusted by the thermostatic expansion valve, which meters the amount of liquid entering the evaporator coil. When adjusting the valve, turning the valve stem counterclockwise two full turns increases superheat about 1 degree. Turning the stem clockwise decreases superheat about 1 degree for each two turns.

The temperature control, which senses outlet air temperature, is a two-stage control. Each stage controls a solenoid valve that, in turn, feeds liquid refrigerant to each section of the aftercooler coil. As delivered air temperature falls below the set point, the first stage of the temperature controls actuates and closes one of the two aftercooler liquid line solenoid valves. Set the temperature to meet the needs of your climate area and to your cooling needs.

Other adjustments available to you are the compressor cylinder unloaders, the hot gas bypass regulator, and the condenser fan speed regulator. You should follow the settings in the technical manual to achieve maximum efficiency from your air-conditioning system.

Testing for Refrigerant Leaks

The best time to test joints and connections in a system is when there is sufficient pressure to increase the rate at which the refrigerant is leaking from the component. There is usually sufficient pressure in the high-pressure side of the system; that is, in the condenser, receiver, and liquid line, including dehydrators, strainers, line valves, and solenoid valves. However, this is not necessarily true of the low-pressure side of the system. Where there is very little pressure, you can increase the pressure in the low-pressure side by bypassing the discharging pressure from the condenser to the low-pressure side through the service gauge manifold. Small leaks cannot be found unless the pressure inside the system is at least 40 to 50 psi, regardless of the method used to test.

HALOGEN LEAK DETECTOR TEST.—The use of a halogen leak detector is the most positive method of detecting leaks in a refrigerant system (fig. 11-27). It is a portable, battery operated electronic leak detector. It is capable of finding leaks as small as ½ ounce per year as well as large leaks in areas where background contamination may be present.

The instrument features a variable frequency alarm signal that gives an indication of the concentration of halogen gases (size of leak). It permits the operator to “home in” on the leak source without continually readjusting the instrument for the changing ambient or background contamination.

The sensing tip (Qutip) at the end of the probe is not adversely affected by large amounts of refrigerant, as are vacuum-type halogen gas detectors. Recovery time after the probe is removed from a contaminated area is virtually instantaneous.

This instrument requires no warm-up period, and it is ready to use following a simple balancing procedure. It is equipped with a dual length flexible probe, which can be bent to permit the sensing tip (Qutip) at the end of the probe to reach normally inaccessible areas.

Always be sure your instrument is off when changing tips. The battery voltage is amplified in the sensing tip (Qutip). Failure to turn the instrument off when changing tips can result in a mild shock and possible damage to the instrument.

When leak detection is necessary, make sure the following steps are taken before use:

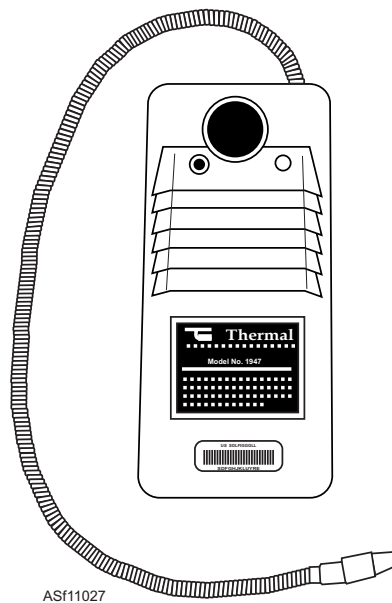

Figure 11-27.—Halogen leak detector.

1. Turn the balance knob clockwise. The red light should be lit indicating the unit is on.

2. To balance the instrument, turn the balance knob fully clockwise to maximum alarm. Turn knob counterclockwise until alarm changes to fastest steady tick, the most sensitive position. Turning the balance knob further counterclockwise will decrease sensitivity.

3. When searching for a leak and a very small amount of halogen gas enters the sensing tip, the ticking signal will speed to a very low hum. As more gas enters the tip, the low hum will change to a low siren. As the concentration continues to build, the alarm signal will continue to increase in frequency until a very high pitch siren is heard. The higher the alarm signal pitch, the heavier the concentration of halogen gas.

4. Due to the expanded dynamic range, large leaks can be detected even in areas of high concentration without resetting the instrument's balance control. After initial setup for maximum sensitivity, and the unit has reached full siren, you can readjust to detect a larger leak by turning knob counterclockwise to a fast steady tick. Repeat as necessary until the source is located. In windy areas, a large leak can be extremely difficult to find because the escaping gas is rapidly carried away from the leak source. Under these conditions, it may be necessary to shield the potential leak area.

5. In a situation where large leaks mask the presence of very small leaks, locate and repair large leaks first. Finding the small leaks will then become an easy task. When trying to locate a very "hard to find leak," first isolate the potential leak area with a drop cloth. Wait a few minutes and probe the shielded area. Continue this practice until all suspected areas have been checked.

6. In areas where background noise is a problem, you may want to use the earphone accessory available for your leak detector. Remember that halogen gases are heavier than air. The first indication of the presence of halogen gases may be slightly below the actual leak source. When searching for leaks, the sensing probe should be moved at the rate of approximately 1 inch per second.

SOAP AND WATER TEST.—Soap and water may be used to test for leakage of any refrigerant having pressure higher than atmospheric pressure. Make a soap-and-water solution by mixing a considerable amount of soap with water to a thick consistency. Let it stand until the bubbles have disappeared, and then

apply it to the suspected leaking joint with a soft brush. Wait for bubbles to appear under the clear, thick, soap solution.

Find extremely small leaks by carefully examining suspected places with a strong light. If necessary, use a mirror to view the rear side of joints or other connections suspected of leaking. Repair all leaks by following the latest repair methods, and service the system after all pump down and system cleaning guidelines are finished. Perform a full system check before returning the unit back to the SE pool for issue.

Charging a System

You will occasionally be required to top off the charge of refrigerant in an air-conditioner. This may be because of leaks or because you have had the system open to work on it. If you have made major repairs, such as to the condenser or receiver, you may have completely emptied the air-conditioner of refrigerant. In which case, you would have transferred the refrigerant to one or more external cylinders for storage. Whatever the circumstances, you must ensure the system is fully charged before it is used.

To replace partial amounts of refrigerant, you will normally charge with gas, a procedure called *low-side* charging. If you have to replace the entire charge of refrigerant, you'll charge with liquid, a procedure called *high-side* charging.

REFRIGERANT STORAGE CYLINDERS.—

Refrigerant can be drawn from the same storage cylinder in either the gaseous or liquid state. A dual port/dual access valve cylinder has two ports. You draw gas from one port and liquid from the other. A single port/single access valve cylinder has only one port. If refrigerant is drawn from an upright cylinder (valve at the top), it will be in the gaseous state. If the cylinder is turned upside down (valve at the bottom), refrigerant is drawn in the liquid state.

LOW-SIDE CHARGING.—In low-side charging, you charge the compressor with gas by using the following procedures.

1. Connect a hose between the center connection of the manifold test set and the cylinder of refrigerant (fig. 11-28). Tighten both connections. If using a single port/single valve cylinder, ensure that the cylinder is in the upright position (valve at the top).

2. Connect a hose from the low-pressure side of the manifold test set to the suction side of the compressor. The service valve on the compressor

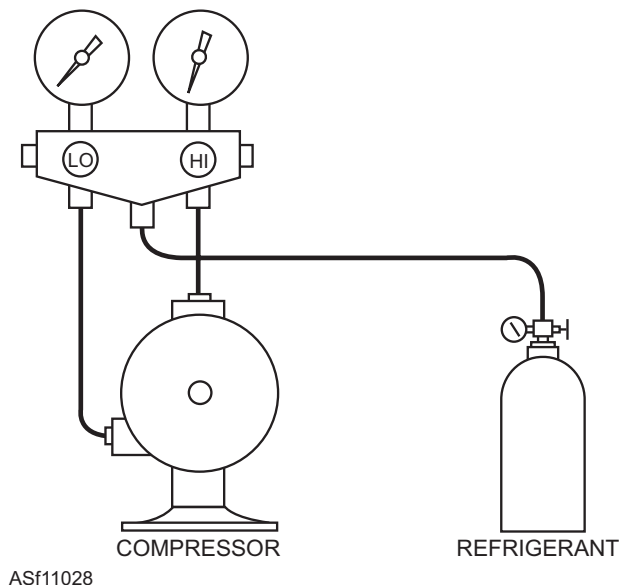

Figure 11-28.—Connections for low-side charging.

should be in the back-seated position (servicing gauge port closed). Leave a loose connection at the compressor.

3. Connect a hose from the high-pressure side of the manifold test set to the discharge side of the compressor. The service valve on the compressor should be in the back-seated position (servicing gauge port closed). Leave a loose connection at the compressor.

4. Open the valve on the cylinder of refrigerant.

5. Crack the low-pressure valve on the manifold to bleed the air from the hose. When refrigerant starts to escape from the suction port, tighten the fitting, and close the manifold valve.

6. Crack the high-pressure valve on the manifold to bleed the air from the hose. When refrigerant starts to escape from the discharge port, tighten the fitting, and close the manifold valve.

7. Set both service valves on the compressor to the mid-seated position. This opens the servicing gauge ports.

8. Open the low-pressure side of the manifold test set.

9. Start the compressor. Refrigerant will be drawn from the storage cylinder to the suction side of the compressor. Add the refrigerant slowly, checking regularly until the system is fully charged. The system has a liquid-line sight glass, and the system is fully charged when there is no bubbling of refrigerant as it passes the glass. The sight glass will appear empty.

CAUTION

In low-side charging, be sure that the refrigerant cylinder is kept in the vertical position at all times to keep liquid refrigerant from entering the compressor.

HIGH-SIDE (LIQUID) CHARGING.—In high-side charging, you charge the receiver with liquid refrigerant by using the following procedures.

1. Connect a hose between the center connection of the manifold test set and the cylinder of refrigerant (fig. 11-29, view A). If using a single port/single access valve cylinder, the cylinder should be in the upright position at this point in the procedure. Tighten both connections.

2. Connect a hose from the high-pressure side of the manifold test set to the receiver inlet valve. The service valve on the receiver should be in the back-seated position (servicing gauge port closed). Leave a loose connection at the service port.

3. Open the valve on the cylinder of refrigerant. The cylinder should still be upright.

4. Crack the high-pressure valve on the manifold to bleed the air from the hose. When refrigerant starts to escape from the service port, tighten the fitting, and close the manifold valve.

5. Set the receiver inlet valve to the mid-seated position. This opens the servicing gauge port.

6. Invert the cylinder of refrigerant, and hang it from a scale (fig. 11-29, view B). Record the weight of the cylinder. (You will normally have a hanging scale available for this purpose, but, alternatively, you can use a platform scale.)

NOTE: In charging with liquid refrigerant, you monitor the weight of the refrigerant that is transferred to the air-conditioner. Starting from empty, the A/M32C-17 should take a charge of 117 to 120 pounds of refrigerant. Tanks of refrigerant are normally 50 to 80 pounds, so it will take more than one tank to fill the receiver of the air-conditioner.

7. Open the high-pressure valve on the manifold to start the flow of refrigerant from the cylinder to the receiver.

8. When you calculate that the proper amount of refrigerant has been transferred, close the valves on the cylinder, the manifold, and the receiver.

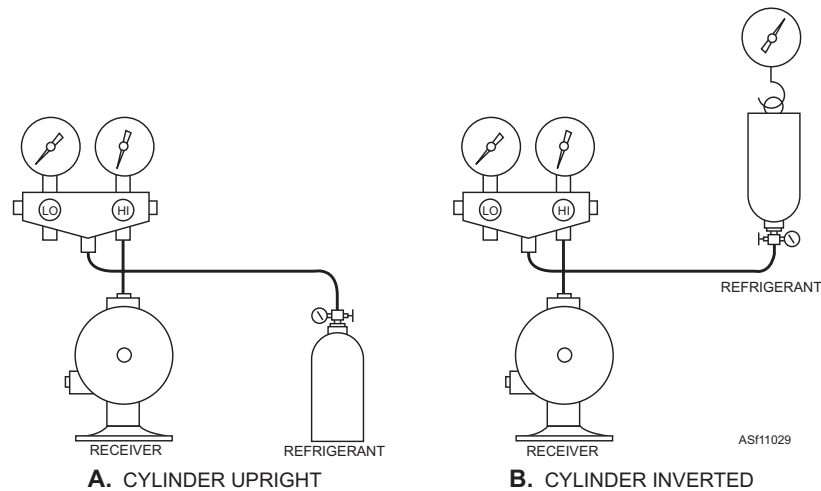

Figure 11-29.—Connections for low-side charging.

9. Disconnect the hoses. Do this carefully, as there will be trapped refrigerant in the lines.

After charging with liquid refrigerant, run the air-conditioner and observe the discharge pressure gauge to ensure system pressure does not exceed 365 psi in the AIR-CONDITION mode. (Normal operating pressure is 100 to 365 psi.) Also check the sight glass to ensure there are no bubbles present in the refrigerant. If bubbles are present, the system is not fully charged, and you will have to add additional refrigerant by using the low-side charging method.

WARNING

Liquid and gaseous refrigerant is very cold and can burn your hands if it comes in contact with your skin. Be sure to wear gloves when handling refrigerant.

Refrigerant Recovery-Recycle

Current regulations forbid venting refrigerant into the atmosphere. Therefore, before opening a refrigerant system, the system must be pumped down to secure the refrigerant, and in some cases, its refrigerant must be transferred to a separate container. For this purpose, the Navy currently uses the ST-100A and ST-1000 refrigerant recovery-recycle systems. (See figure 11-30 and table 11-4.)

NOTE: Functionally, the two systems are virtually identical. In the technical manual, the manufacturer discusses the systems as though they were one and refers to them as the ST-100A/ST-1000. We will do the same.

A second function performed by the ST-100A/ST-1000 is to filter refrigerant. The unit accepts refrigerant from the external system in either liquid or gas form, filters it, and then returns it as a liquid directly to the external system or to a separate storage tank to be reused (fig. 11-31). Operating instructions for the ST-100A/ST-1000 and system specifics can be found in *Operational and Intermediate Maintenance Instructions with Illustrated Parts Breakdown, Refrigerant Recovery-Recycle System, ST-100A-USN, ST-100, NAVAIR 19-60-91.*

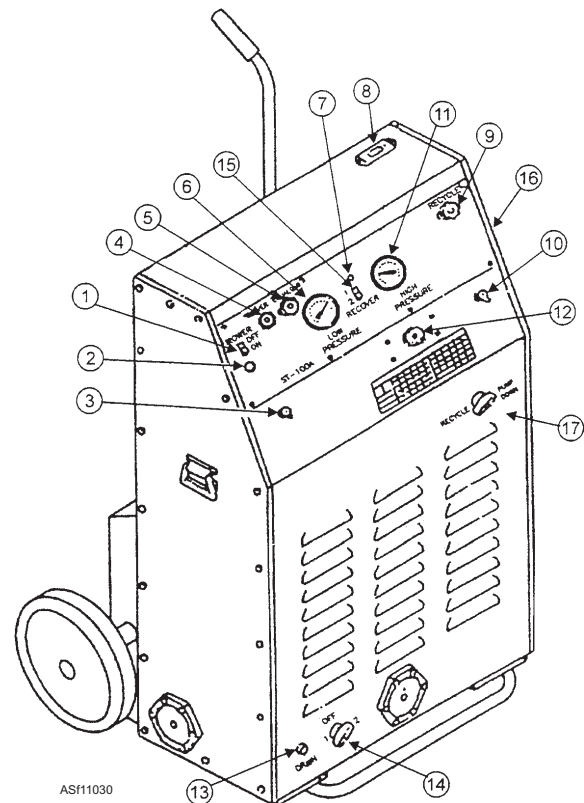

Figure 11-30.—Refrigerant recovery-recycle units.

Table 11-4.—Controls and Indicators for the Refrigerant Recovery-Recycle Units

INDEX NO.	CONTROL/INDICATOR	FUNCTION
1	Control Switch	Controls the electrical system.
2	Circuit Breaker	Protects the electrical system.
3	Recover Port	Connection for plant drain valve hose.
4	Recover Valve	Opens recover port.
5	Equalize Valve	Allows to equalize the high and low internal pressures for ease to start up under load and draining of oil.
6	Low Pressure Gauge	Indicates compressor suction pressure.
7	Tank Full Light	Disconnected when used with tank full bypass jumper and Navy standard refrigerant cylinders.
8	Hour Meter	Indicates the elapsed operating time.
9	Recycle Valve	Opens recycle port.
10	Recycle Port	Connects hose to refrigerant cylinder.
11	High Pressure Gauge	Indicates high pressure going to the refrigerant cylinder.
12	Moisture Indicator	Indicates moisture level of recycled refrigerant.
13	Oil Drain Port	Connection to attach hose for draining contaminated oil.
14	Oil Drain Selector Valve	For selection of No. 1 or No. 2 accumulator for oil draining.
15	Recover Switch	For selection of type of recovery operation (No. 1 for liquid, high oil, and acid or No. 2 for vapor and light contamination.)
16	Tank Cable Receptacle	Jumpered with MOLEX plug (tank full bypass jumper) when used with Navy standard refrigerant cylinders.
17	Pump Down Valve	Allows pump down of unit for refrigerant change.

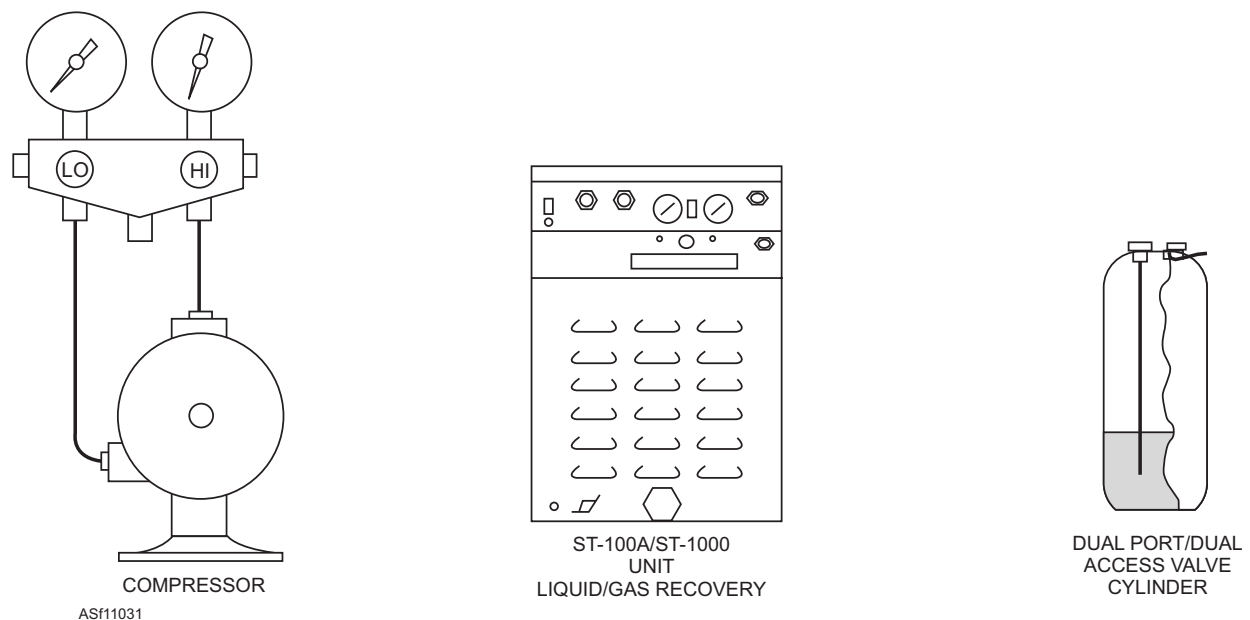

Figure 11-31.—Refrigerant recovery method.

Troubleshooting

The following chart (table 11-5) details some of the more common problems encountered in troubleshooting an A/M32C-17 mobile air-conditioner. Also listed are suggested ways to fix the problems. Some of the steps may seem complicated, but they are really basic troubleshooting procedures with which you need to become familiar. As always, for more detailed information, refer to the technical manual NAVAIR 19-60-87.

SAFETY PRECAUTIONS

Working on air-conditioners can be very dangerous if safety precautions are not taken. The following safety precautions are mandatory to prevent injury to personnel working on or in the immediate vicinity of air-conditioning units.

- Use approved goggles or a face shield when handling refrigerants.
- Do not allow liquid refrigerant to contact the skin.

Table 11-5.—Troubleshooting the A/M32C-17

INDICATION	PROBABLE CAUSE	SUGGESTED REMEDY
A. Compressor fails to start	<ol style="list-style-type: none"> 1. Electromagnetic clutch not operating 2. Broken or sheared coupling 3. Seized compressor, locked or damaged mechanism 4. Suction pressure below setting of low-pressure 5. Discharge pressure above cut-in setting of high-pressure cutout switch 6. Oil failure switch cutout 	<ol style="list-style-type: none"> 1. Replace or repair electromagnetic clutch. 2. Replace coupling. 3. Overhaul compressor. 4. Check for loss of refrigerant. Repair leaks and recharge. 5. Refer to G below. 6. Check compressor oil level, oil pressure, wiring and controls.
B. Compressor “Short-Cycles”	<ol style="list-style-type: none"> 1. Low-pressure controller differential set too close 2. High-pressure controller differential set too close 3. Reduced airflow. Iced evaporator. <ol style="list-style-type: none"> a. Dirty air filter b. Broken fan belt c. Improper fan belt tension 4. Leaking liquid line solenoid valve. 5. Overcharge of refrigerant or noncondensable gas in system 6. Insufficient refrigerant 7. Restricted drier strainer 	<ol style="list-style-type: none"> 1. Reset low-pressure cutout, or replace. 2. Reset high-pressure cutout or replace. 3. Clean or defrost evaporator coils. Check filters and fan drive. 4. Repair or replace valve. 5. Remove excess refrigerant or purge noncondensable gas and check for leaks. 6. Repair refrigerant leak and recharge. 7. Clean or replace strainer

Table 11-5.—Troubleshooting the A/M32C-17—Continued

INDICATION	PROBABLE CAUSE	SUGGESTED REMEDY
C. Compressor runs continuously	<ol style="list-style-type: none"> 1. Excessive load. Infiltration of warm air. Insulation of conditioned area. 2. Thermostat set too low 3. Lack of refrigerant—bubbles in sight glass 4. Overcharge of refrigerant—high discharge pressure 5. Leaky compressor valve—compressor noisy or abnormal suction and discharge pressure 6. Solenoid valve stuck open 	<ol style="list-style-type: none"> 1. Check for infiltration of outside air into conditioned area. Check insulation. 2. Reset or replace thermostat. 3. Repair leak and charge system. 4. Remove excess refrigerant. 5. Overhaul compressor. 6. Repair or replace valve.
D. Compressor loses oil	<ol style="list-style-type: none"> 1. Oil level too low 2. Clogged strainers or valves 3. Loose expansion valve remote bulb—excessively cold suction 4. Crankcase fittings leak 	<ol style="list-style-type: none"> 1. Add sufficient oil. 2. Clean and repair or replace. 3. Establish good contact between remote bulb and suction line. 4. Repair oil leak and add sufficient oil.
E. Noisy compressor operation	<ol style="list-style-type: none"> 1. Loose drive coupling 2. Lack of oil—compressor cuts out on oil failure control 3. Dry or scored seal—squeak or squeal when compressor runs 4. Internal parts damaged—compressor knocks 5. Expansion valve stuck open 6. Compressor or clutch loose on base 	<ol style="list-style-type: none"> 1. Tighten coupling and check alignment. 2. Add oil. 3. Check oil level. 4. Overhaul compressor. 5. Repair or replace. 6. Tighten hold-down bolts. Check alignment.
F. System short of capacity	<ol style="list-style-type: none"> 1. Flash gas in liquid line—expansion valve hisses 2. Clogged strainer or solenoid stop valve 3. Ice or dirt on evaporator coils 4. Expansion valve stuck or obstructed 5. Excess pressure drop in evaporator—super heat too high 	<ol style="list-style-type: none"> 1. Add refrigerant. 2. Clean or replace. 3. Clean or defrost coils. 4. Repair or replace valve. 5. Check superheat and reset thermostatic expansion valves.

Table 11-5.—Troubleshooting the A/M32C-17—Continued

INDICATION	PROBABLE CAUSE	SUGGESTED REMEDY
G. Discharge pressure too high	<ol style="list-style-type: none"> 1. Hydraulic pump belt broken or condenser tubes dirty 2. Air or noncondensable gas in system 3. Overcharge of refrigerant, excessively hot condenser and discharge pressure 	<ol style="list-style-type: none"> 1. Check fan belt and clean exterior of condenser. 2. Purge and check for leaks. 3. Remove excess.
H. Discharge pressure too low	<ol style="list-style-type: none"> 1. Lack of refrigerant—bubbles in sight glass 2. Broken or leaking compressor discharge valve(s). Suction pressure rises faster than 5 lb/min after pressure shutdown 3. Unloader(s) stuck open 4. Leaking hot gas bypass valve 	<ol style="list-style-type: none"> 1. Repair leaks and recharge. 2. Remove head. Examine valves, and replace faulty valves. 3. Inspect and repair or replace unloaders. 4. Remove and inspect valve. Replace if necessary.
I. Suction pressure too high	<ol style="list-style-type: none"> 1. Excessive load on evaporator—compressor runs continuously 2. Over-feeding of expansion valve—abnormally cold suction line; liquid feeding back to compressor 3. Expansion valve stuck open—abnormally cold suction line; liquid feeding back to compressor 4. Broken suction valves in compressor 	<ol style="list-style-type: none"> 1. Refer to C above. 2a. Check to be sure that remote bulb is firmly in contact with suction line. 2b. Check superheat setting of expansion valve. 2c. Repair or replace expansion valve. 3. Repair or replace valve. 4. Remove head, examine valves, and replace those found to be inoperative.
J. Suction pressure too low	<ol style="list-style-type: none"> 1. Lack of refrigerant—bubbles in sight glass 2. Clogged liquid line strainer—temperature change across strainer 3. Obstructed expansion valve 4. Thermostat stuck closed 5. Compressor capacity control set too low—compressor short cycles 	<ol style="list-style-type: none"> 1. Repair leak and recharge. 2. Clean or replace strainer. 3. Clean or replace valve. 4. Repair or replace thermostat. 5. Reset compressor capacity control range.

- Do not inhale refrigerant vapors.
- NEVER heat refrigerant drums or tanks with a flame.
- NEVER heat any part of a refrigerating system if the refrigerant is stored within.
- When repairing a refrigerant pipe or tubing, always purge the refrigerant gas out of the line before applying a torch.
- NEVER put liquid refrigerant into a compressor suction side.
- NEVER fill a refrigerant cylinder to more than 80 percent of its capacity.
- Be careful when working near rotating or moving components.
- Do not work on energized electrical circuits unless absolutely necessary.
- If possible, work in pairs or teams (crews).

FIRST-AID TREATMENT FOR REFRIGERANT BURNS

If liquid refrigerant comes in contact with your skin, a serious burn may result. Such an injury should be treated as if the skin were frostbitten or frozen, which is to wash or immerse the area in clean water that is slightly above body temperature (104 to 113°F). The exposed area should then be loosely wrapped with a clean, dry dressing. If the refrigerant should come in contact with your eyes, flush them out with clean cool water. In either case, seek immediate medical attention.

Q11-20. In what location is the A/M32C-17 air-conditioning unit intended to be used?

1. On the flight deck of an aircraft carrier
2. On the flight line of a naval air station
3. In the hanger bay of an aircraft carrier
4. In the hanger bay of an amphibious assault ship

Q11-21. Which of the following is NOT a mode of operation of the A/M32C-17?

1. Cool
2. Dehumidify
3. Ventilate
4. Humidify

Q11-22. Which of the following modes of operations on the A/M32C-17 will pump all of the refrigerant into the receiver until the low-pressure cutout stops the compressor?

1. Pump down
2. Dehumidification
3. Ventilation
4. Humidify

Q11-23. What is the purpose of the middle hose on the refrigerant manifold test set?

1. It is connected to the low-pressure side when servicing the unit with refrigerant
2. It is connected to the refrigerant supply cylinder when servicing the unit with refrigerant
3. It is connected to the high-pressure side when servicing the unit with refrigerant
4. It is connected to the low-pressure side when removing the refrigerant from the system

Q11-24. How much recovery time is required by the halogen leak detector probe after being removed from a contaminated area?

1. 1 minute
2. 2 minutes
3. 5 minutes
4. It is virtually instantaneous

Q11-25. When charging a refrigeration system, what type of refrigerant is used to charge the high side to the system?

1. Cool Gas
2. Warm Vapor
3. Cool Liquid
4. Super heated vapor

Q11-26. Which of the following items does the Navy use to recover and recycle refrigerant?

1. BTU-110
2. ST-1000
3. RT-310
4. ST-2000

Q11-27. Which of the following discrepancies could be the cause for noisy compressor operation?

1. Solenoid valve defective
2. Overcharge of refrigerant
3. Leaky compressor valve
4. Loose drive coupling

GAS TURBINE COMPRESSORS

INTRODUCTION

Gas turbines are a familiar sight on the flight decks of aircraft carriers and the flight lines of naval air stations. They are most often tractor mounted aboard ship and trailer mounted at shore commands. The primary use of gas turbine engines is to provide pneumatic power to start aircraft engines. The pneumatic bleed-air power is high-volume, low-pressure compressed air, which is used to operate equipment that requires a high volume of air. This includes aircraft engine starter motors, air-conditioning systems, and aircraft generator test stands.

As an AS, you are required to maintain and repair gas turbine engines used in support equipment. The prolonged life and operational readiness of the gas turbine engine invariably depend upon the familiarity maintenance personnel have with the equipment.

It is essential that you know the engine as thoroughly as possible. You should know what it is designed to do and how it fulfills that function. You should also be familiar with normal operating details of the engine, such as oil pressures, temperatures, fuel pressures, flows, consumption, and exhaust gas temperatures. You should be familiar with all of these operating conditions from starting to idle, from idle to load, and from load to shutdown of the engine.

DESCRIPTION AND PURPOSE OF GAS TURBINE ENGINES

- **LEARNING OBJECTIVE:** Identify the two types of gas turbine compressor engines. Identify their various components.

Basically, there are two types of gas turbine engines—the centrifugal-flow type and the axial-flow type. (See figures 12-1 and 12-2.) By studying these figures, you can see that the greatest single difference is in the compressor section. The construction features of the compressor (axial-flow or centrifugal-flow) determine the designation of the engine.

The centrifugal-flow compressor engine is the most common engine used in support equipment. The

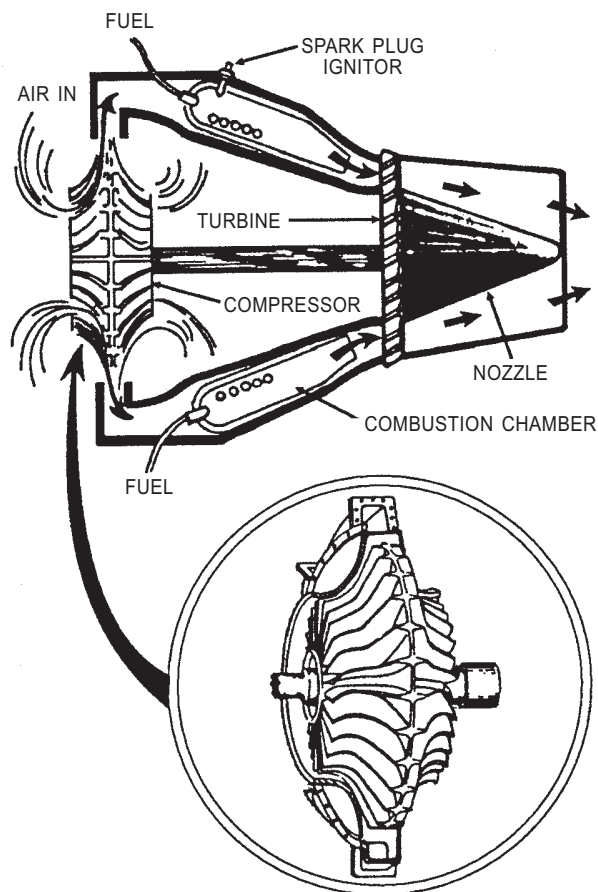

COMPRESSOR - CENTRIFUGAL - FLOW
(DOUBLE - ENTRY TYPE)

ASF12001

Figure 12-1.—Centrifugal-flow type engine.

advantages of the centrifugal type over the axial-flow type are as follows:

- Simplicity of design and manufacture, thus lower cost
- Lighter weight
- Low starting power requirements

Because the centrifugal-flow is the most commonly used in support equipment, the axial-flow will not be discussed. However, by understanding the centrifugal-flow type, the axial-flow type can also be understood, since all other sections and components except the compressor are very similar in design and operation.

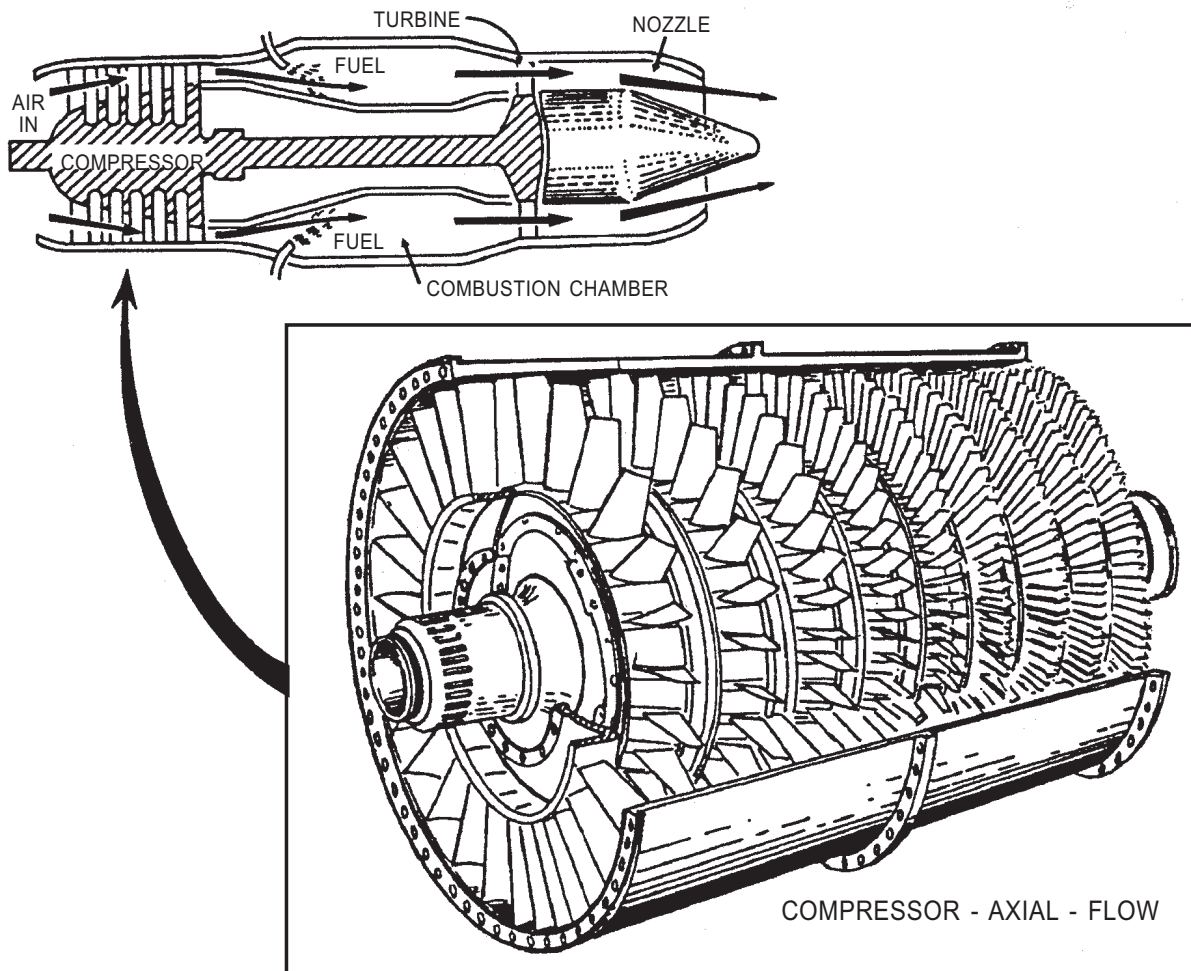

Figure 12-2.—Axial-flow type engine.

ASF12002

The gas turbine engine consists of the following major sections and systems:

- Accessory section
- Compressor section
- Turbine section
- Fuel
- Lubrication system
- Electrical system
- Bleed-air system

Gas turbine compressors provide pneumatic power in the form of compressed bleed air for operation of large-class pneumatic equipment. This equipment includes aircraft main engine starters and other types of compressed air consumers. These units can also be used safely for the removal of ice and snow from aircraft surfaces and for heating and preheating. Usually the units are self-contained and require only an

outside source of fuel and oil to maintain a constant output.

There are many types of configurations of gas turbine compressors. However, because of their similarity in construction and operation, the gas turbine compressor and its systems and configurations are discussed generally in this course.

Q12-1. What is the most common of the two types of gas turbine compressor engines used in support equipment?

1. An axially-flow
2. A centrifugal-flow
3. A rotary-flow
4. A geometrical-flow

Q12-2. Which of the following is NOT a major section of a gas turbine engine?

1. The accessory section
2. The compressor section
3. The intake section
4. The turbine section

PNEUMATIC POWER GAS TURBINE ENGINE, MODEL GTC-85-72

LEARNING OBJECTIVES: Identify the components of GTC-85-72 electrical, fuel, bleed air, and lubrication systems.

This engine consists of a two-stage, centrifugal-flow compressor directly coupled to a radial, inward-flow, single-stage turbine. There are several different configurations of the GTC-85-72 in use. The major difference is the type of enclosure installation used. The most common is the GTC-85 enclosure mounted at the rear of the A/S32A-31A aircraft tow tractor (fig. 12-3).

The gas turbine compressor takes air, compresses it, adds fuel, ignites the mixture, and directs the expanded gas against a turbine. A large mass of air is required by the gas turbine engine. The inlet must supply as much as 10 times the amount of air required by a reciprocating engine. The air must reach the compressor in a smooth flow free from turbulence.

The function of the compressor is to increase the pressure of the air received from the entrance duct, and then discharge it to the combustion chamber in the quantity and at the pressure desired. The power to drive the compressor is provided by the turbine. The turbine and compressor units and their connecting shafts comprise the rotating assembly. The rotating assembly is the only major moving part in the gas turbine. Because its motion is entirely rotary, operation is inherently smooth.

The combustion chamber serves to contain the combustion process, which raises the temperature of the air passing to the turbine. The combustion process injects fuel into the compressed air and ignites the mixture. This process releases the potential energy contained in the fuel-air mixture. Approximately 30 percent of the air from the compressor combines with the fuel mixture in the combustion process. The other 70 percent of the air is used for cooling at 100-percent no load. The cooling air is mixed with the combustion gases, which lowers the temperature of the gases to a

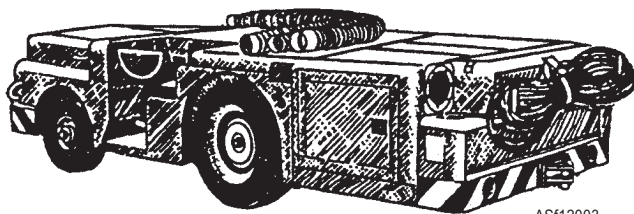

ASf12003

Figure 12-3.—Tractor-mounted gas turbine enclosure.

level safe enough for turbine operation as it is expelled through the exhaust.

The turbine receives the heated gases and transforms the energy of the burned gases to shaft power that drives the compressor and accessories. The heat causes the compressed air to expand. The only outlet from the combustion chamber is through the turbine. In its rush to escape, the gases build up enough velocity to turn the turbine. The turbine and compressor are connected by a torsion shaft. The accessory section operates by a gear reduction drive connected to the front of the compressor shaft.

The compressed air is drawn off from the turbine plenum for use as pneumatic air. If all the air were routed to the turbine from the compressor, the turbine would produce more power than is needed to operate the compressor and accessories. Therefore, the amount taken for pneumatic equipment operation would not reduce the desired output of the engine. (In a jet engine used in aircraft, where pneumatic air is not bled off, this excess energy is used for propulsion.)

MAJOR COMPONENTS

The gas turbine engine, which is normally referred to as a unit, consists of a two-stage centrifugal compressor directly coupled to a radial inward-flow turbine wheel. Compressed air is obtained as bleed air from the second stage of the compressor, which also supplies air to support fuel combustion in the turbine section. The unit is composed of three main sections—accessory, compressor, and power turbine (fig. 12-4).

Accessory Section

The accessory section is designed as a separate assembly and consists of a gear reduction drive coupled directly to the compressor shaft through a torsion shaft. The accessory housing mounts and provides drives for the following accessories:

- Starter
- Centrifugal switch
- Oil pump assembly
- Generator
- Fuel accessory assembly (fuel pump and control unit)

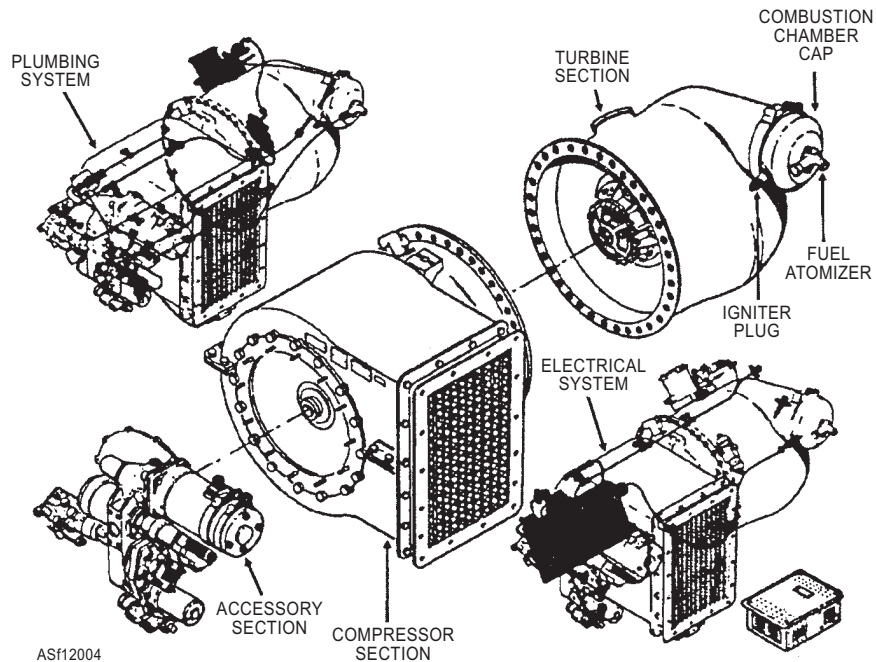

Figure 12-4.—Major sections of a gas turbine compressor (GTC-85).

Compressor Section

This section provides a source of compressed air for combustion, cooling, and pneumatic power in the form of bleed air.

The ambient air is moved by the first and second stage impellers, and is directed through diffusers that are mounted directly after the impellers. Compression is accomplished by the diffusers due to their divergent shape.

The impellers are mounted on a common shaft. The ends of impellers are splined internally to receive the drive shafts, which connect the compressor to the accessory drive shaft and connect the turbine to the compressor.

Power Turbine Section

The turbine section is the power section, which provides driving power for the entire unit. The major parts of this section are the turbine wheel, turbine plenum, combustion chamber assembly, and nozzle assembly. Air, which has been taken into the compressor, is routed to the combustion chamber section where it is mixed with fuel and ignited. As the fuel-air mixture is burned, the gases expand rapidly, increasing the velocity of the gas as it is exhausted to the rear through the nozzle assembly. From the nozzle assembly, these hot gases are directed onto the blades of the turbine wheel, turning the turbine at a very high speed. In turn, the turbine drives the compressor and the accessory drive assembly.

FUNCTIONAL SYSTEMS

Before you attempt to operate a gas turbine unit, you should have a knowledge of the different systems and the function performed by each. In the gas turbine unit there are four main functional systems, which are listed as follows:

- Airflow
- Fuel and bleed-air control system
- Lubrication system
- Electrical system

Airflow

In figure 12-5, note that the rotation of the compressor creates a low-pressure area at the inlet side of the unit. This draws air through the oil cooler into the first stage compressor plenum chamber (air supply chamber). Also note that the first stage of the compressor is constructed with a dual-entry; this is necessary to provide the large volume of air that is required for engine combustion and cooling and for supplying pneumatic power.

As air is drawn into the first stage of the compressor, tremendous velocity is imparted to it by the first stage impeller. The air is then directed into the first stage diffuser, where it is slowed down and its pressure increased (first stage compression) to approximately 18 psi. It is then directed through interstage ducts into the second stage of the

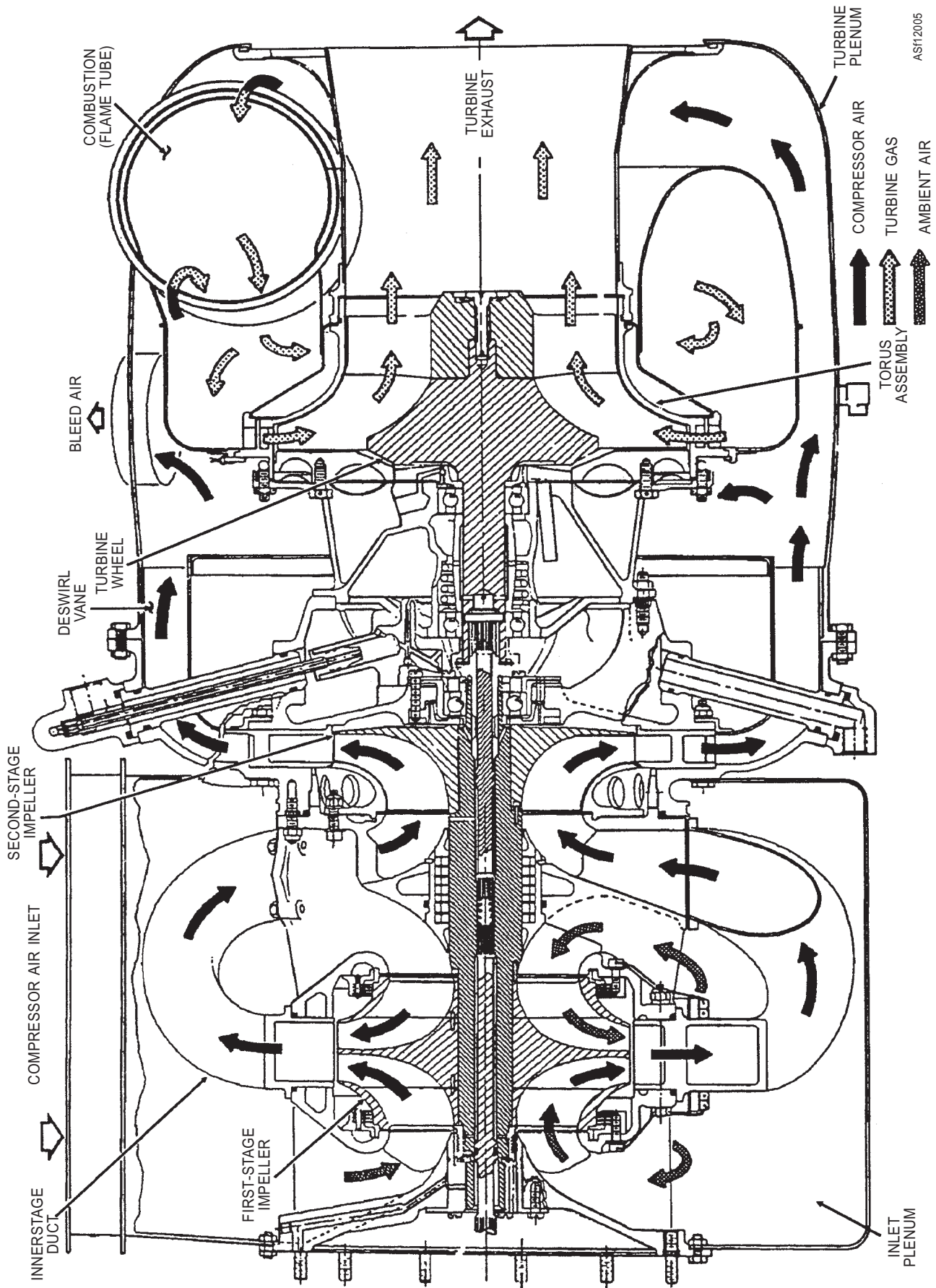

AS112005

Figure 12-5.—Airflow through compressor and turbine.

compressor, and tremendous velocity is again imparted to it by the second stage impeller. It is then directed into the second stage diffuser, where it is slowed down and its pressure further increased (second stage compression) to approximately 37.5 psi.

From the second stage compressor, the air is directed through a set of *deswirl* vanes where, as the term *deswirl* implies, the air is straightened out into a smooth flow as it enters the turbine plenum chamber. Approximately 70 percent of the air entering the turbine plenum chamber is used to support combustion and for combustion chamber cooling, while the remaining 30 percent is available as bleed air for operation of pneumatic equipment. When no air is being bled from the engine, this 30 percent provides additional engine cooling, enabling the engine to operate at reduced temperatures under no-load conditions.

Air enters the combustion chamber via small holes or perforations in the flame tube or liner, where it is combined with fuel and burned. The result of burning the fuel is the rapid expansion of burning gases and creation of a high-velocity, high-energy exhaust gas flow. This gas flow is collected in an assembly, referred to as the torus, and directed through a nozzle ring surrounding the turbine wheel and onto the blades of

the turbine wheel at the proper angle to drive it. The high-velocity, high-energy exhaust gas flow drives the turbine (hence the term *gas turbine*) at a very high rate, providing the power to drive the compressor and accessories and to support pneumatic loads. After passing through the turbine blades, the exhaust gases (still hot) pass out the tail pipe to the atmosphere. A heat shield mounted on the turbine wheel end of the bearing carrier prevents excessive heat from penetrating the turbine wheel shaft to the bearings.

Ventilation is provided within the enclosure by action of the aspirating exhaust duct that draws air through louvers located in the front and rear of the enclosure, and discharges it around the exhaust. Heat shields are provided to protect the battery and the oil tank. The battery heat shield, located between the battery and the exhaust duct, is louvered. Aspiration of the duct pulls air through the louvers in the front panel, around the battery, through the louvers in the heat shield, and out the exhaust.

Fuel and Bleed-Air Control System

The fuel and bleed-air control system, as shown in figure 12-6, functions automatically to maintain a near-constant turbine operating speed under varying conditions of load. The system consists of fuel,

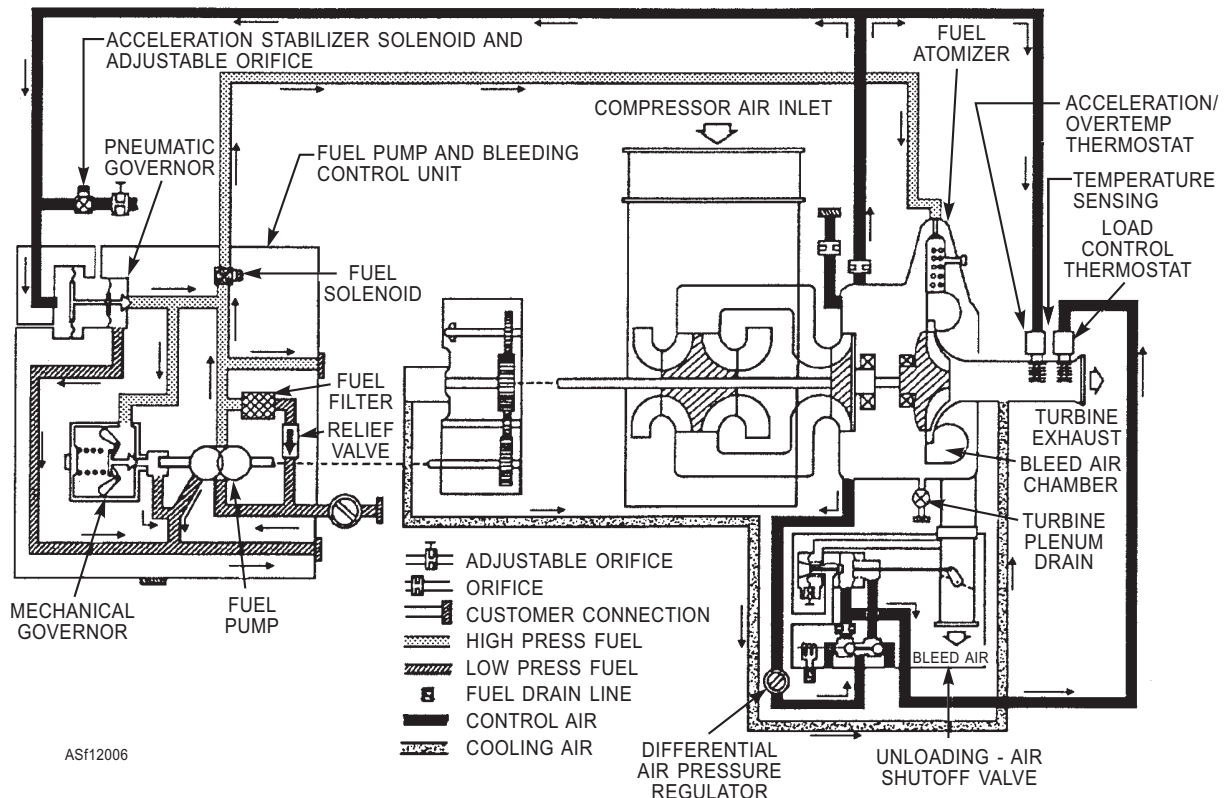

Figure 12-6.—Fuel and bleed-air control system.

electromechanical and pneumatic components with connecting plumbing and wiring. The principal components of the system are a fuel pump and control unit with solenoid valve, an acceleration stabilizer solenoid and adjustable orifice assembly, a fuel atomizer assembly, an acceleration control thermostat, a turbine plenum drain check valve, an unloading air shutoff valve with solenoid valve, a differential air pressure regulator, and a bleed load thermostat.

FUEL PUMP AND CONTROL UNIT.—The fuel pump and control unit incorporate the fuel pump, a fuel filter, a pneumatic governor (bypass) valve, a fuel pressure relief valve, a flyweight-type (mechanical) governor, and a fuel solenoid valve.

The integral fuel pump is a two-gear, positive displacement pump. The pump housing contains a spring loaded, ball-type pressure relief valve which returns fuel to the pump inlet to relieve excess fuel pressure. The fuel filter, integral with the fuel pump and control unit in a case, filters all fuel passing from the fuel pump to the fuel control system components. The filter case is threaded into the pump and control unit housing and contains a replaceable micronic filter element.

The pneumatic governor consists of a relief valve actuated by two diaphragms—one controlled by fuel pressure and the other by a combination of spring pressure and compressor discharge (control) air pressure. It is called a *bypass valve* because it is designed to control fuel flow to the atomizer assembly by bypassing a portion of the fuel delivered by the fuel pump back to the fuel pump inlet.

As engine rpm increases and compressor discharge air pressure increases, less fuel is bypassed and more is delivered to the atomizer assembly. The pneumatic governor controls fuel flow during starting and acceleration up to approximately 95% of governed engine rpm.

The mechanical governor begins to function as engine rpm reaches approximately 95%. Enough centrifugal force is applied to the flyweights at this point to allow the governor to begin bypassing fuel, and simultaneously, the pneumatic governor bypass relief valve is locked closed by the increased compressor discharge pressure. The mechanical governor allows just enough fuel to reach the atomizer assembly to maintain governed engine rpm.

The fuel solenoid valve is the normally closed type. It admits or shuts off fuel flow to the atomizer

assembly in response to electrical control system operation.

ACCELERATION STABILIZER AND ADJUSTABLE ORIFICE ASSEMBLY.—The acceleration stabilizer and adjustable orifice assembly consists of a normally open solenoid valve and an adjustable air bleed installed in the control air line between the pneumatic governor and the acceleration control thermostat. Its purpose is to control and stabilize the rate of acceleration by bleeding control air pressure off the air diaphragm of the pneumatic governor. Bleeding off a portion of the air pressure from the air diaphragm causes the valve to bypass more fuel, decreasing the rate of acceleration. The solenoid is energized (closed) during starting (up to 35 percent of governed engine rpm) and when the load switch is actuated, allowing the pneumatic governor to close and provide the increased fuel flow required at these times to support engine operation.

FUEL ATOMIZER ASSEMBLY.—The fuel atomizer assembly is a dual orifice type and is mounted on the combustion chamber cap assembly. A flow divider valve directs all fuel at low pressure to the small orifice, which provides proper atomization of the fuel during starting. As engine rpm increases and fuel pressure increases, the flow divider valve actuates to permit combined flow to both orifices.

ACCELERATION CONTROL THERMOSTAT.—The acceleration/overtemp control thermostat is mounted in the engine tail pipe. It consists of a spring-loaded, closed, ball relief valve, and is actuated by exhaust gas temperature (EGT). It is connected to the pneumatic governor by a control air line. The thermostat acts to override control of fuel flow by dumping some control air pressure from the air diaphragm of the pneumatic governor if the EGT exceeds a specified limit during acceleration.

TURBINE PLENUM DRAIN CHECK VALVE.—The turbine plenum drain check valve is located at the bottom of the turbine plenum. It allows fuel to drain, except when compressor pressure is built up in the turbine plenum. The valve purpose is to prevent accumulation of unburned fuel in the turbine plenum.

UNLOADING AIR SHUTOFF VALVE.—The unloading air shutoff (load) valve assembly consists of a normally closed solenoid valve, a normally closed butterfly valve, and two diaphragms. It functions to control the amount of air that is bled from the engine in relation to EGT. If too much air is being bled off

(overloading), action of the bleed-load control thermostat allows the butterfly valve to close sufficiently to regulate bleed-air flow without causing engine shutdown or loss of engine speed.

DIFFERENTIAL AIR PRESSURE REGULATOR.—The differential air pressure regulator, secured to the top of the turbine plenum, provides a constant control-air pressure to the unloading air shutoff valve under all conditions for opening and closing of the valve.

LOAD CONTROL THERMOSTAT.—The load control thermostat is mounted in the engine tail pipe. It has the same construction as the acceleration control thermostat and is connected to the load valve by a control air line. It functions to control the bleed load in relation to EGT. At a specified temperature, the thermostat valve opens and bleeds control air pressure from the actuator diaphragm of the load valve. This reduction in control air pressure allows the butterfly valve to modulate, thereby maintaining the maximum permissible bleed load on the engine and preventing overheating of the engine.

Lubrication System

The lubrication system is very simple; but, because of the temperatures and rpm at which the unit operates, positive feed oil pressure for lubrication and cooling must be provided. The system includes a pressure and scavenge pump, an oil filter, an oil temperature regulator, an oil cooler, an oil tank, and an oil drain solenoid valve (fig. 12-7). Oil under pressure is supplied to all gears, shafts, and bearings. After the oil has been used, it collects in the common sump between the compressor and turbine assemblies and in the sump of the accessory section; it is then returned, by the scavenge pump, to the oil tank.

If the temperature of the oil is such that it requires cooling, it is routed through the oil cooler. Cooling is accomplished by compressor inlet air flowing around the tubes of the oil cooler. If the temperature of the oil is not great enough to require cooling, a bypass valve in the temperature regulator routes the oil directly to the oil tank, where it is again pumped through the engine. The unit is provided with an oil pressure actuated switch, which prevents the engine from starting until oil pressure builds up sufficiently to close the switch.

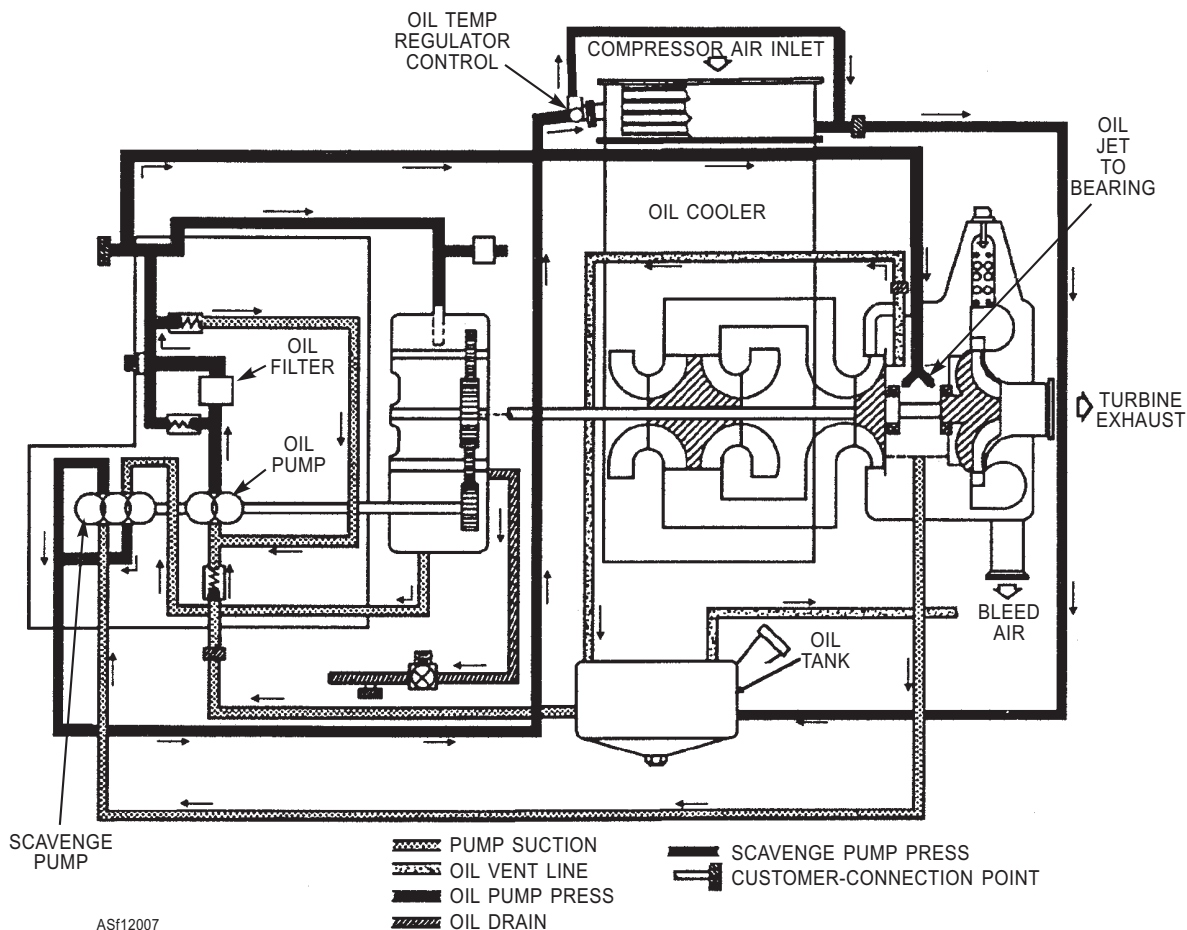

Figure 12-7.—Lubrication system.

Also, if oil pressure is lost during operation, this switch functions to shut down the engine. Sometimes, the oil pump requires priming to provide oil pressure at the time of starting. The oil drain solenoid valve drains excess oil from the accessory section during engine deceleration.

Electrical System

The electrical system provides the means for starting, operating, and stopping the engine. It is a 26 ± 2 -volt dc system, which may be operated from a battery or an external power source, such as a mobile electric power plant. The electrical system has two groups of components—engine mounted and enclosure mounted. The engine group is the same for all installations, but the enclosure group varies as to type of components and circuitry. A typical electrical system schematic is shown in figure 12-8.

The components of the engine group are the electrical control box, the ignition system, the generator, the starter motor assembly, the centrifugal switch assembly, the oil drain solenoid valve, the fuel solenoid valve, the acceleration stabilizer solenoid and adjustable orifice assembly, and the oil pressure switch.

ELECTRICAL CONTROL BOX.—Electrical control of the engine is maintained through the electrical control box (fig. 12-9). It houses the starter and ignition holding relay, fuel holding relay, ignition unit, and the start counter. The starter and ignition holding relay and the fuel holding relay, when energized, provide power to the circuits they control and also to their own coils for a holding action. The ignition unit provides the high-tension current to the igniter plug.

IGNITION SYSTEM.—The gas turbine engine ignition system is very simple in construction and operation. The entire system consists of the igniter (spark unit), which is located in the combustion chamber; a section of high-tension ignition lead; and the ignition unit, which provides the high-energy voltage source. This is accomplished by a step-up transformer, which charges internal storage capacitors. The storage capacitors are then discharged across a booster coil arrangement, and the high voltage is applied to the igniter. After the engine has started and a flame is established in the combustion chamber, the ignition system is de-energized, since burning is constant once a successful start has been accomplished.

NOTE: The voltage to the igniter is dangerously high (near 15,000 volts of pulsating dc); therefore,

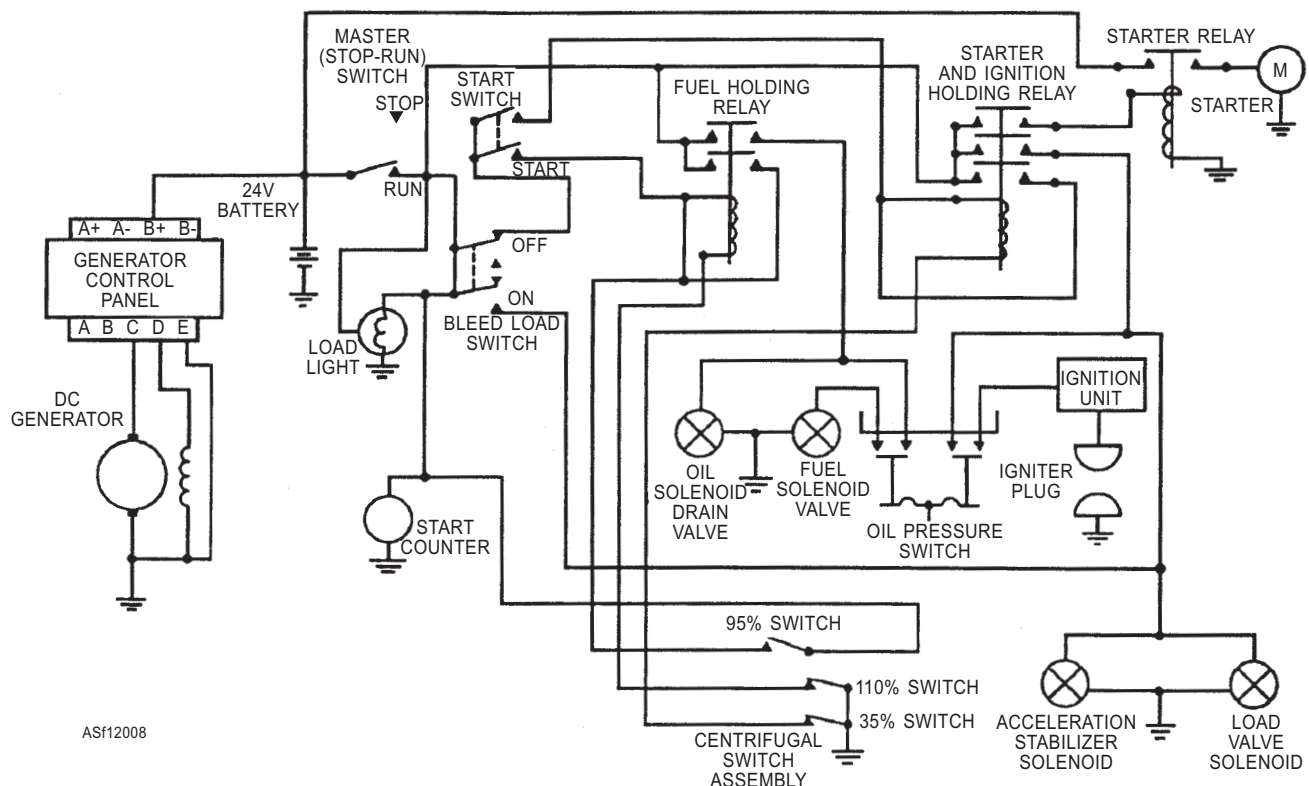

Figure 12-8.—Electrical system.

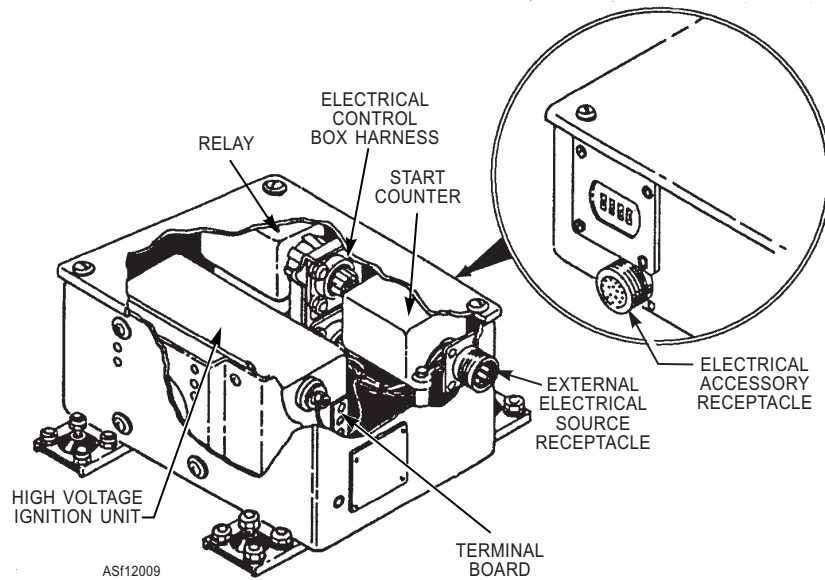

Figure 12-9.—Electrical control box.

caution must be observed when maintenance is performed on the ignition system. Always make certain that the capacitors are fully discharged before removing or checking components of the ignition system.

GENERATOR.—The generator, driven by the accessory drive gear section, is a continuous-duty unit rated at 12 amperes and 28 volts. Cooling of the generator is provided by air drawn through cooling inlet holes in the generator housing, through the generator, into a cooling outlet tube, and into the turbine exhaust. Control of the generator and the circuits associated with it is the function of the voltage regulator and reverse current relay. These units and a noise filter are located in the generator control panel.

STARTER MOTOR ASSEMBLY.—The starter unit operates on a 24- to 28-volt power supply; power for operation of the starter may be provided by a battery or may be supplied from an alternate external 28-volt source. The starter is provided with a clutch mechanism, which allows automatic initial engagement, and disengagement is accomplished when the speed of the accessory drive is exceeded. Starter motor current is cut off at 35 percent of engine speed.

CENTRIFUGAL SWITCH ASSEMBLY.—The centrifugal switch assembly (fig. 12-10), through the operation of a set of flyweights, controls the sequence of operation of the electrical system. As the flyweights are caused to move outward by centrifugal force, three switches are actuated by an actuating lever.

The first to operate is the 35-percent switch, which de-energizes the starter and ignition holding relay. The second to operate is the 95-percent switch, which energizes the ready-to-load light, load switch circuit, and the start counter. The last switch to operate, the 110-percent switch, operates at 110 percent and is a safety device to protect the engine from overspeed.

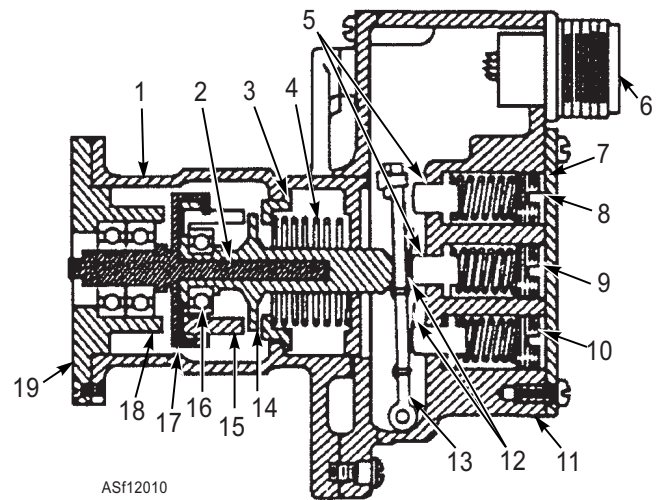

- | | |
|-----------------------------|--------------------------------------|
| 1. Housing | 11. Switch cover |
| 2. Centrifugal switch shaft | 12. Leaf spring |
| 3. Spring sliding retainer | 13. Switch actuating lever |
| 4. Compression spring | 14. Lever actuator |
| 5. Push rod | 15. Governor flyweights |
| 6. Receptacle | 16. Ball bearing |
| 7. Access plate | 17. Fulcrum flyweights |
| 8. Adjusting screw | 18. Overspeed switch bearing carrier |
| 9. Adjusting screw | 19. Mounting flange |
| 10. Adjusting screw | |

Figure 12-10.—Centrifugal switch assembly.

When this switch operates, the fuel holding relay is de-energized and the engine stops.

The principal components of the enclosure group are a starter relay, generator control panel, and an engine control panel. The engine control panel provides the operating controls and instruments for monitoring engine operation.

OIL DRAIN SOLENOID VALVE.—The normally open oil drain solenoid valve is connected to a plumbing line from the accessory section; it drains excess oil from the accessory section during deceleration of the engine or in the event that the inlet check valve sticks open. When the engine is operating, the drain solenoid is energized to close.

FUEL SOLENOID VALVE.—The fuel solenoid valve is a normally closed electromagnetic shutoff valve, and it is a component of the fuel pump and control unit. The valve functions to admit or shut off fuel to the combustion chamber in response to electrical control system operation.

ACCELERATION STABILIZER SOLENOID AND ADJUSTABLE ORIFICE ASSEMBLY.—The acceleration stabilizer solenoid and adjustable orifice assembly is located on the upper compressor inlet plenum. The assembly consists of a normally open solenoid valve and an adjustable orifice assembly installed in the control air line between the acceleration thermostat and the fuel pump pneumatic governor. Its purpose is to stabilize acceleration of the engine by regulating control air, causing the pneumatic governor to bypass fuel and limit engine acceleration rates. The solenoid is energized from 0 to 35 percent, and de-energized from 35 to 100 percent unloaded. The solenoid is energized during bleed-load operation (100-percent loaded).

OIL PRESSURE SWITCH.—The oil pressure switch is mounted on the back of the compressor plenum. It uses two microswitches to initiate ignition and fuel flow to the combustion chamber during the engine start cycle.

PREOPERATIONAL INSPECTION

The preoperational Maintenance Requirements Cards require a thorough visual inspection of the unit, and you should remember that these are the minimum requirements prior to starting.

If any discrepancies exist, take the necessary steps to have them corrected so the unit will be ready for use when it is needed again. Disconnect and stow the air

hose, disconnect the battery, and secure the access panels.

The equipment manual for the particular gas turbine being operated should be consulted for proper starting and shutdown procedures.

CAUTION

If difficulty occurs when starting, do not exceed the duty cycle of the starter—1 minute ON, 4 minutes OFF.

SYSTEM OPERATION

With the master (stop-run) switch in the run position, power is available to the start switch through the load switch in its OFF position, the test circuit of the load light, the contacts of the fuel-holding relay, and the contacts of the starter and ignition-holding relay. (Refer back to figure 12-8.) Depressing the momentary contact start switch energizes the coils of the fuel-holding and the starter and ignition-holding relays. The fuel-holding relay energizes the oil solenoid drain valve, the fuel side of the oil pressure switch, the normally open 95-percent switch, and its own coil. Ground for the fuel-holding relay coil is through the normally closed 110-percent switch. The starter and ignition-holding relay energizes the starter relay, acceleration stabilizer solenoid, load valve solenoid, ignition side of the oil pressure switch, and its own coil. Ground for the starter and ignition-holding relay is through the normally closed 35-percent switch. The relay energizes the starter motor, which begins rotating the engine.

At about 5,000 rpm, rising oil pressure closes the oil pressure switch, energizing the ignition unit then the fuel solenoid valve. Combustion is initiated; the engine begins to accelerate under the combined drives of the starter and combustion until approximately 15,000 rpm (35 percent) is reached. At this time the 35-percent switch opens the ground circuit to the coil of the starter and ignition-holding relay, causing it to open. This action de-energizes the starter relay, ignition unit, acceleration stabilizer solenoid, and the load valve solenoid. The engine continues to accelerate and as approximately 42,000 rpm (95 percent) is reached, the 95-percent switch closes, energizing the load light (indicating that a load may now be applied), start counter, and the circuit to the load switch. The engine is loaded by placing the load switch in the ON position. This energizes the load valve solenoid and the

acceleration stabilizer solenoid. If at any time the engine speed reaches 110 percent, the 110-percent switch opens, opening the ground circuit to the coil of the fuel-holding relay, causing it to open. This action de-energizes the fuel solenoid valve and the bleed-load valve circuit. Fuel flow to the engine is stopped, the load valve closes, and the engine is shut down.

SYSTEM FUEL CONTROL

Fuel flow to the engine determines engine rpm and turbine temperature, and must be accurately controlled. During starting and acceleration, fuel is controlled by the fuel pump and control unit, acceleration overtemp thermostat, and fuel atomizer assembly. The pneumatic portion of the fuel pump and control unit functions during the starting cycle to increase fuel pressure in relation to the increase of compressor pressure by reducing the amount of fuel allowed to bypass, thus increasing the pressure applied to the fuel atomizer assembly. If the turbine temperature exceeds the specified value during the start cycle, the acceleration overtemp thermostat opens and allows more fuel to bypass, thereby reducing the pressure of the fuel applied to the fuel atomizer assembly.

The fuel atomizer assembly is constructed with a dual discharge orifice; this arrangement includes a valve called a *flow-divider valve*, which remains closed at low pressure (starting pressures) and opens as acceleration increases, allowing an increase of fuel to flow at higher rpm. The correct amount of fuel is supplied to the engine and is properly atomized at all speeds.

GOVERNED OPERATION

After the engine has reached a steady state, this condition is maintained from no-load to full-load (except when the engine is overloaded) by the fuel pump and control unit. The mechanical governor of the fuel pump and control unit automatically regulates the fuel flow to match the power demands placed upon the turbine wheel, maintaining a substantially constant turbine wheel speed. This is done by sensing the speed of the turbine through the flyweights of the control unit. During underspeed condition, the governor restricts fuel bypass, which increases the pressure applied to the fuel atomizer assembly; this, in turn, increases turbine speed. To compensate for an overspeed condition, fuel flow is decreased by bypassing more fuel and reducing the pressure of the

fuel applied to the atomizer assembly. A serious overspeed could damage the engine. Therefore, it is the function of the 110-percent switch to open—which, in turn, will close the fuel solenoid valve and cut the supply of fuel off. This will stop the engine when overspeed occurs.

Q12-3. Which of the following sections of a turbine is designed to increase the pressure of the air and discharge it to the combustion chamber?

1. The turbine section
2. The accessory section
3. The combustion section
4. The compressor section

Q12-4. Which of the following sections of a gas turbine engine contains the starter, oil pump, centrifugal switch, the fuel pump, and the generator?

1. The accessory section
2. The compressor section
3. The turbine section
4. The enclosure section

Q12-5. Which of the following components of the fuel control unit is designed to control fuel to the atomizer and deliver a portion of the fuel received from the fuel pump back to the pump inlet?

1. The discharge valve
2. The bypass valve
3. The metering valve
4. The check valve

Q12-6. How does the acceleration stabilizer control and stabilize the rate of acceleration?

1. By limiting the output of the fuel pump
2. By limiting the amount of air taken into the engine
3. By bleeding control air pressure off the diaphragm and bypassing fuel away from the engine
4. By increasing fuel pressure to the atomizer during low-speed conditions by using an accumulator

Q12-7. What type of fuel atomizer is used on the gas turbine engines found in support equipment?

1. A full flow
2. A dual orifice
3. A variable output
4. A adjustable nozzle

- Q12-8. Which of the following components is installed on the gas turbine engine to prevent accumulation of unburned fuel in the turbine plenum?*
1. A drain check valve
 2. An overflow valve
 3. A pressure valve
 4. A discharge valve
- Q12-9. The oil of a gas turbine compressor is cooled by what means?*
1. By using the intake air as a cooling agent
 2. By using a fan to circulate air over the oil tank
 3. By cooling it with a radiator
 4. By passing it through an oil cooler when the oil gets hot
- Q12-10. The generator on a gas turbine compressor is driven by what means?*
1. By a belt and pulley on the front of the engine
 2. By the accessory drive gear section of the engine
 3. By an electric motor located on the enclosure
 4. By a pneumatic motor driven by compressed air from the engine
- Q12-11. Which of the following is NOT a switch located in the centrifugal switch?*
1. The 10-percent switch
 2. The 35-percent switch
 3. The 95-percent switch
 4. The 110-percent switch
- Q12-12. When is the acceleration stabilizer solenoid energized?*
1. When the engine is in a loaded condition
 2. When the engine is between 35 percent to 100 percent of rated speed
 3. When the engine is between 0 percent and 35 percent of rated speed
 4. When the engine is in a 100-percent unloaded condition
- Q12-13. Which of the following components removes the ground circuit from the starter and ignition holding relay?*
1. The oil-pressure switch
 2. The start switch
 3. The 95-percent switch
 4. The 35-percent switch

PNEUMATIC POWER GAS TURBINE ENGINE, MODEL GTCP-100

LEARNING OBJECTIVES: Identify the components of GTCP-100 electrical, fuel, bleed air, and lubrication systems.

The GTCP-100 gas turbine engine (fig. 12-11) is a compact and essentially self-sufficient source of mechanical and pneumatic power. Either form of power may be used independently of the other, or both may be used simultaneously. Mechanical power is available as shaft power at the takeoff pad located on the accessory housing. Pneumatic power is available as clean, compressed air delivered through a modulating valve located on the turbine plenum. An external source of fuel, oil, and electrical power for starting and control is provided by the enclosure and turbine control panel.

COMPONENTS OF THE ENGINE

As with the GTC-85, the GTCP-100 engine is composed of three main sections: the accessory drive section, located at the front; the turbine section, located at the rear; and the compressor section, located in the middle area (fig. 12-12). The engine also includes the same main systems that are incorporated into the GTC-85 engine. Individual accessories comprise the remaining parts of the engine.

Airflow through the GTCP-100 engine is virtually the same as that of the GTC-85 engine. Ambient air enters the engine through the screened compressor inlet plenum and is compressed by the two stages of the compressor section (fig. 12-13). This compressed air is directed into the turbine plenum, where a portion may be diverted for pneumatic power uses. The balance is directed into the six combustion chambers where it is mixed with fuel. The mixture is ignited by an igniter plug, and continuing combustion adds heat and velocity. The gases of combustion are directed into the vanes of the turbine wheels to provide power for the engine. Spent gases are exhausted through a duct assembly at the rear of the engine. Power produced at the turbine wheel drives the compressor and provides the drive for the accessory section through a series of drive shafts and gear trains.

Accessory Drive Assembly Section

The accessory drive assembly section consists of a set of reduction gears and drive shafts housed in a case

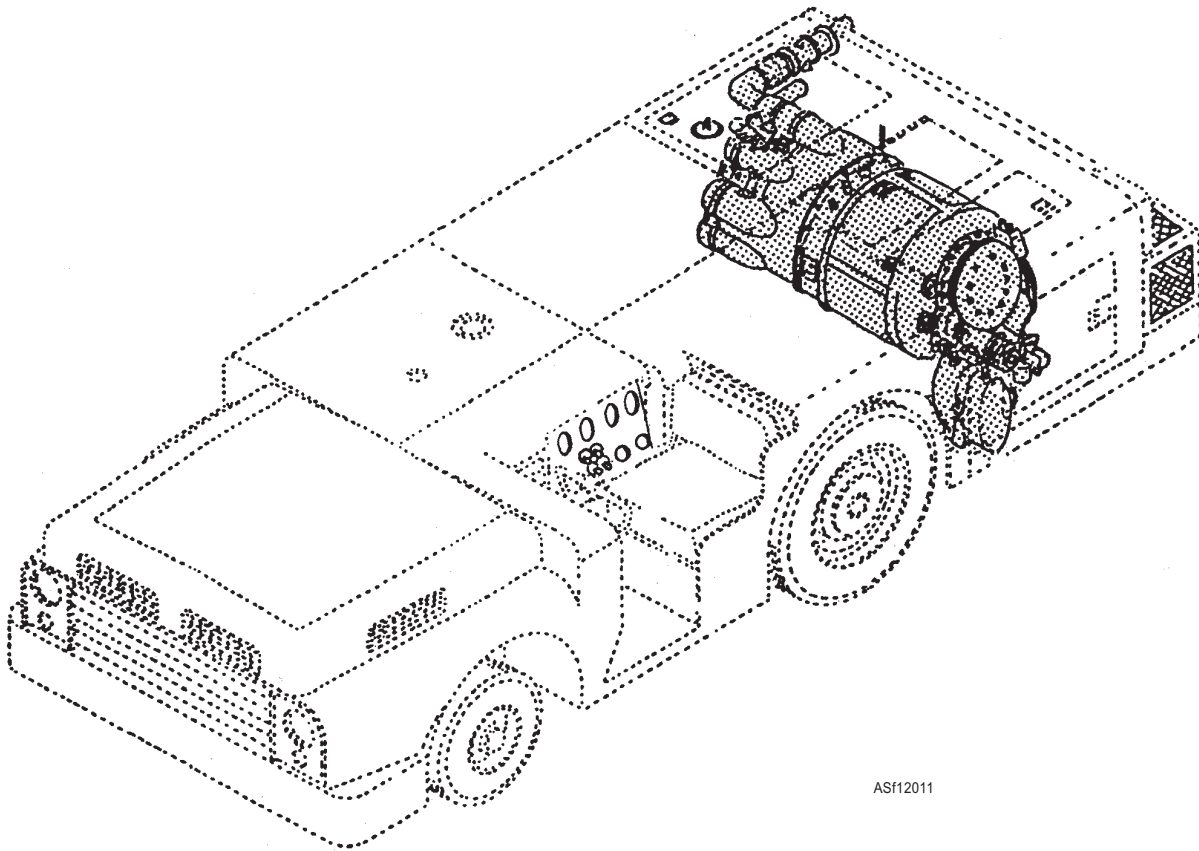

ASf12011

Figure 12-11.—GTCP-100 gas turbine engine in enclosure.

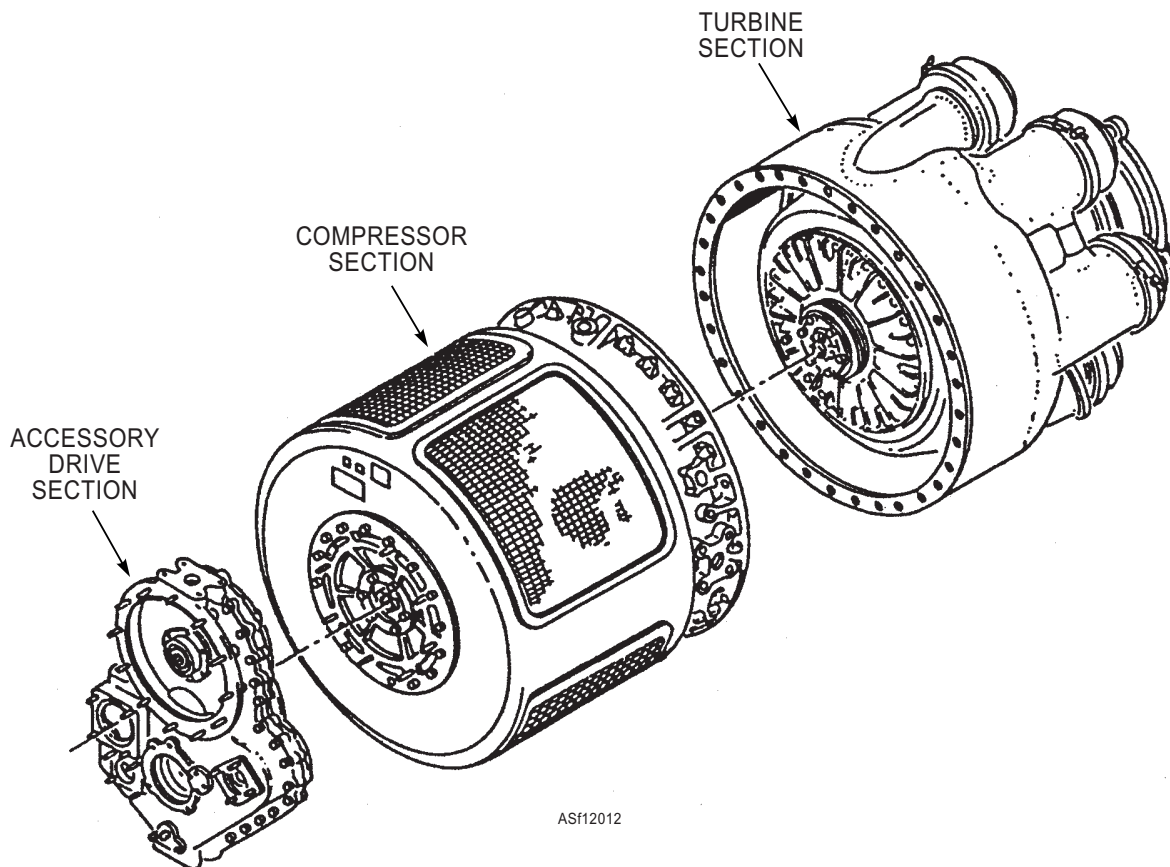

ASf12012

Figure 12-12.—GTCP-100 gas turbine engine sections.

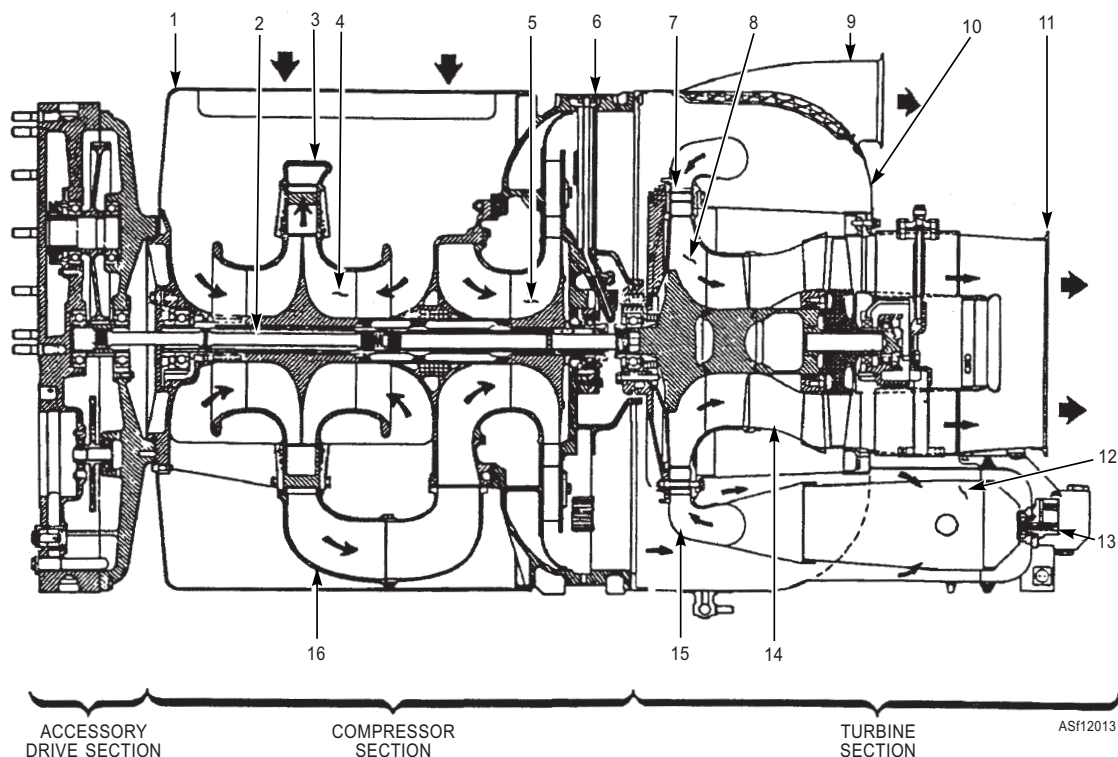

- | | |
|--|---|
| <ol style="list-style-type: none"> 1. Compressor plenum assembly 2. Torsion shaft 3. Crossover duct 4. Compressor first stage impeller 5. Compressor second stage impeller 6. Compressor oil jet assembly 7. Turbine radial nozzle assembly 8. Turbine radial wheel and shaft assembly | <ol style="list-style-type: none"> 9. Bleed-air outlet duct 10. Turbine plenum assembly 11. Turbine exhaust duct 12. Combustion chamber 13. Fuel atomizer assembly 14. Turbine nozzle and shroud assembly 15. Combustion collector manifold assembly 16. Crossover duct |
|--|---|

Figure 12-13.—Engine airflow schematic.

that mounts on the front end of the compressor section. A torsion shaft, driven by the compressor rotating assembly, is coupled to and drives the main pinion gear. Through various reduction gears, the pinion gear provides output drives for the fuel control, oil pump, centrifugal switch, and the power output shaft. An input drive and gearing is provided for the electrical engine starter.

ENGINE FURNISHED ACCESSORIES.—

The accessories (as viewed from the exhaust) are part of the gas turbine engine (fig. 12-14) and include the following:

- A starter (9) mounted on the right front of the accessory case
- A start-counter assembly (8) mounted in a bracket on the right side of the accessory case
- An ignition unit (16) and a two-stage oil pressure switch (22) mounted on the left side of the accessory case
- A pneumatic shutoff valve (21) located on the bottom left rear of the turbine plenum
- A fuel shutoff and drain solenoid valve (14) located at the bottom rear of the turbine assembly
- Two pneumatic thermostats (19 & 20) located in the turbine exhaust duct area (only one on the GTC-100-82 model)
- A fuel control (23) mounted on the left front of the accessory case
- An oil pump (12) mounted on the front bottom of the accessory case
- A three-speed centrifugal switch (10) mounted on the lower right front of the accessory case

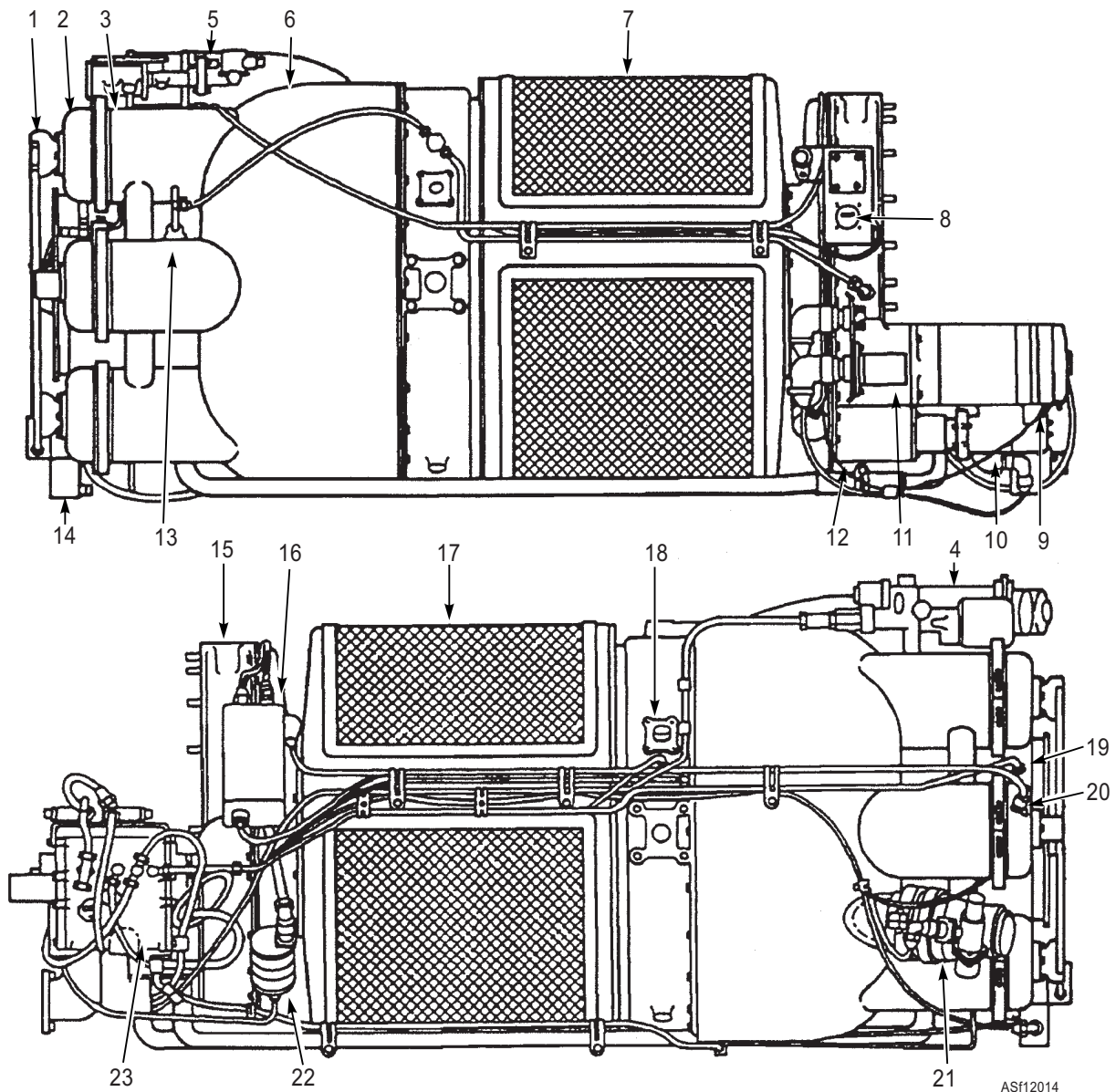

- | | | |
|---------------------------------|--|---|
| 1. Atomizer assembly | 10. Centrifugal switch assembly | 18. Pressure tap |
| 2. Cap assembly | 11. Relay | 19. Thermostat (acceleration and overtemp) |
| 3. Combustion chamber | 12. Oil pump assembly | 20. Igniter plug on #5 combustion chamber |
| 4. Modulating and shutoff valve | 13. Thermostat (load control) | 21. Valve (pneumatic shutoff, air scheduling) |
| 5. Bleed-air duct | 14. Shutoff and drain solenoid valve assembly (fuel) | 22. Oil pressure switch |
| 6. Turbine section | 15. Accessory assembly | 23. Fuel (metering) control assembly |
| 7. Compressor section | 16. Ignition unit | |
| 8. Start counter | 17. Compressor air inlet screen | |
| 9. Starter motor assembly | | |

Figure 12-14.—Right and left view of a gas turbine engine.

- Six fuel atomizer assemblies (1) attached to the combustion cap assemblies at the rear of the engine
- A modulating and shutoff valve (4) mounted on the top rear of the turbine plenum

ENCLOSURE PROVIDED ACCESSORIES.—A temperature-regulated oil cooler, vane axial oil cooler fan and ducting, an oil tank, as well as a primary fuel filter with shutoff, a fuel boost pump, and the related supply/return lines are located within the enclosure assembly. In addition, the turbine control

panel is considered part of the enclosure, and it is physically located in the operator's compartment.

Turbine Section

The turbine assembly section consists of a rotating assembly, housing, plenum, and combustion chamber components. The rotating assembly includes a radial turbine wheel and shaft assembly with an axial turbine wheel mounted on the radial wheel shaft. A shroud is over the radial wheel; a nozzle is in front of the axial wheel; pressure-lubricated bearings and bearing housings are on each end of the assembled wheels. Seals are installed between the wheels and adjacent bearings to prevent leakage of lubricating oil into the turbine inlet and exhaust air.

The rotating assembly is mounted within a support assembly and containment ring. It is enveloped by a combustion collector manifold and a plenum assembly. The manifold incorporates six ducts, which mate with six combustion chamber liners. The plenum assembly fits over the manifold and has six ducts that envelope the combustion chamber liners. The six combustion cap assemblies are attached to the plenum assembly ducts.

The engine uses six combustion chambers of the reverse flow can type, equally spaced axially around the turbine section (fig. 12-15). The turbine plenum and the attached combustion cap assemblies constitute the outer shell of the combustion chambers. The combustion collector manifold ducts connect to the discharge end of the combustion chamber liners and

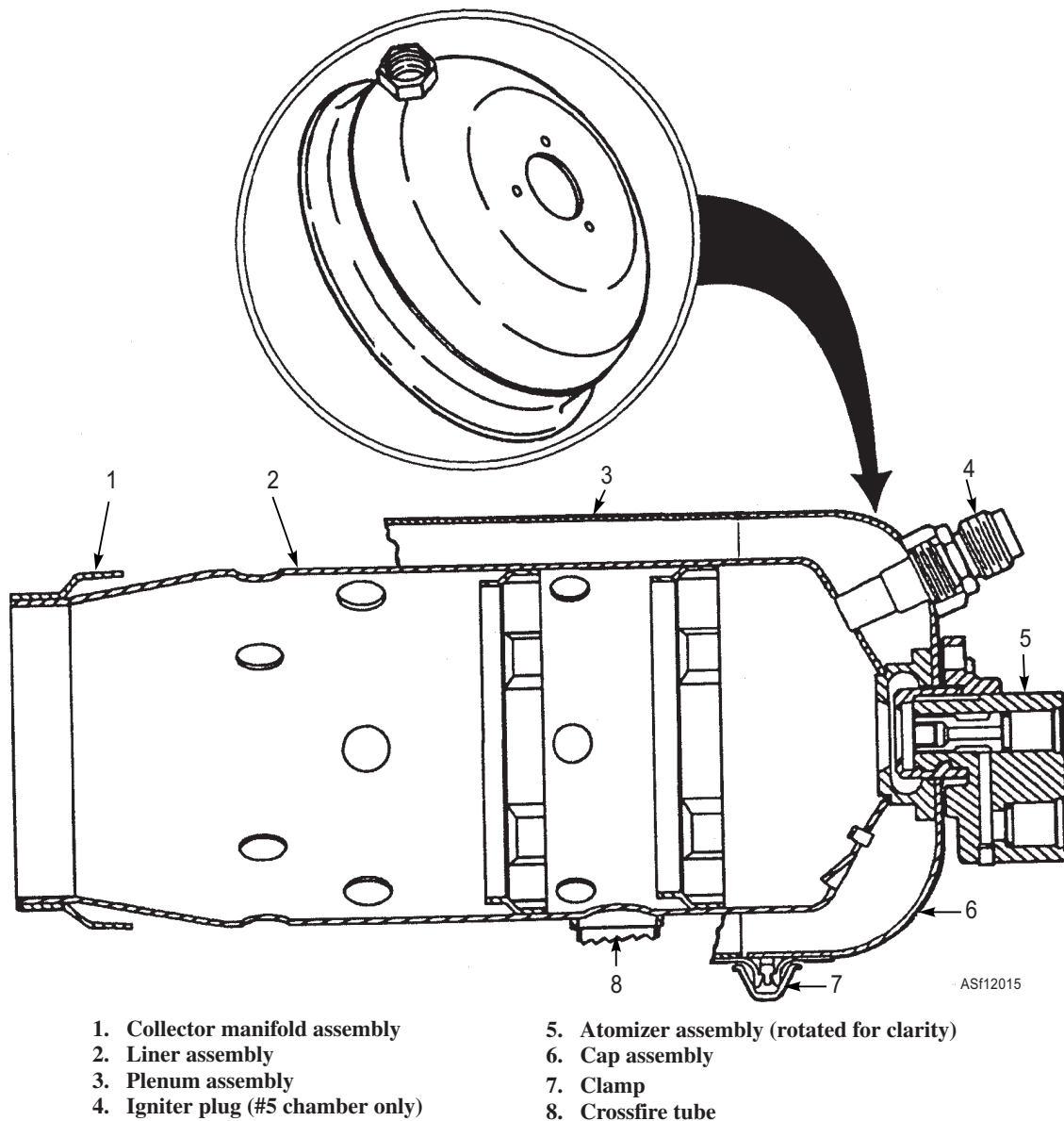

Figure 12-15.—Combustion chamber construction.

comprise the inner shell of the combustion chambers. The liners are perforated with holes and slots of correct sizes and locations for proper control of combustion. Six cross-fire tubes are ceramic coated and interconnect the six combustion chamber liners. One igniter plug is mounted on a pad on the No. 5 combustion cap assembly to provide ignition. Six fuel atomizer assemblies mount through the combustion chamber caps and into the ends of the combustion chamber liners to provide proper fuel spray. The two pair of fuel manifold assemblies attached to the fuel atomizer assemblies distribute the fuel supply.

Compressor Section

The compressor assembly section consists of a rotating assembly, housings, eight crossover ducts, and a plenum assembly. The rotating assembly includes a first-stage, dual radial wheel and a second-stage, single radial wheel mounted on a common shaft, wheel shrouds, and housing. A torsion shaft is driven by the turbine rotating assembly. It is coupled to the internal spline of the compressor shaft and drives the compressor rotating assembly. The impeller wheels and shaft are supported by bearings and bearing housings on each end of the shaft. The bearings are pressure lubricated, and seals are installed between the wheels and adjacent bearings to prevent leakage of lubricating oil into the compressed air system.

The rotating assembly is mounted in support assemblies and housings. Crossover ducts direct the compressed air from first-stage to second-stage impellers. A diffuser housing directs fully compressed clean air into the turbine plenum. The compressor plenum assembly envelops the other compressor assembly components and provides screened inlets for the compressor air supply.

SYSTEMS OF THE ENGINE

The description and operating principles of the fuel, air, lubrication, and electrical systems, as well as their components, are discussed in the following text.

Fuel System

The fuel system consists of fuel and pneumatic control components and the necessary interconnecting plumbing (fig. 12-16). The main component of the system is the fuel control assembly (fig. 12-17), which incorporates, within one unit, a gear-type pressure pump, a fuel filter, a relief valve, a mechanical (flyweight) governor, and a fuel scheduling valve

(pneumatic governor). Other components of the system are six fuel atomizer assemblies, a fuel shutoff and drain solenoid valve, an air-pressure-ratio solenoid valve (two-speed valve), an acceleration and overtemperature control thermostat, a plenum drain valve, and a normally closed auxiliary fuel solenoid valve.

The system functions to provide fuel for combustion at controlled rates under varying conditions of engine speed, load, and discharge temperature. Fuel from the fuel supply is filtered by a replaceable filter element and pumped by the fuel control to the fuel atomizer assemblies. Fuel flow is metered by the fuel scheduling valve (pneumatic governor) during starting operation and by the mechanical governor during normal operation.

After the engine start switch is actuated, and when engine oil pressure reaches a preset value, the primary contacts in the oil pressure switch close and energize the ignition unit. Within 1 psig following the primary contact closing pressure, the oil pressure switch secondary contacts close and energize the fuel shutoff and drain solenoid valve. This closes the fuel drain section and opens the primary side of the flow divider valve in the normally closed fuel shutoff section to permit fuel flow to the fuel atomizer assemblies. When fuel pressure reaches 125 psig, the flow divider valve opens completely to provide full fuel flow to the fuel atomizer assemblies.

Fuel spray into the combustion chambers is accomplished by dual orifice fuel atomizer assemblies. The smaller orifice in the atomizer provides proper fuel atomization at lower fuel pressures; a combination of smaller and larger orifices provide proper fuel spray at higher fuel pressure.

Control of fuel flow to maintain required engine speed is provided by action of the mechanical governor's flyweights, which modulate the position of the governor fuel bypass valve. Control of fuel flow to maintain proper engine discharge temperature is provided by action of the acceleration and overtemperature control thermostat, which bleeds control air from one side of the fuel scheduling valve's diaphragm. This causes a reduced fuel pressure to the fuel atomizer assemblies, thereby reducing turbine temperature.

Anytime the output air switch is selected, the normally closed auxiliary fuel solenoid valve energizes open to permit additional fuel flow for higher load requirements.

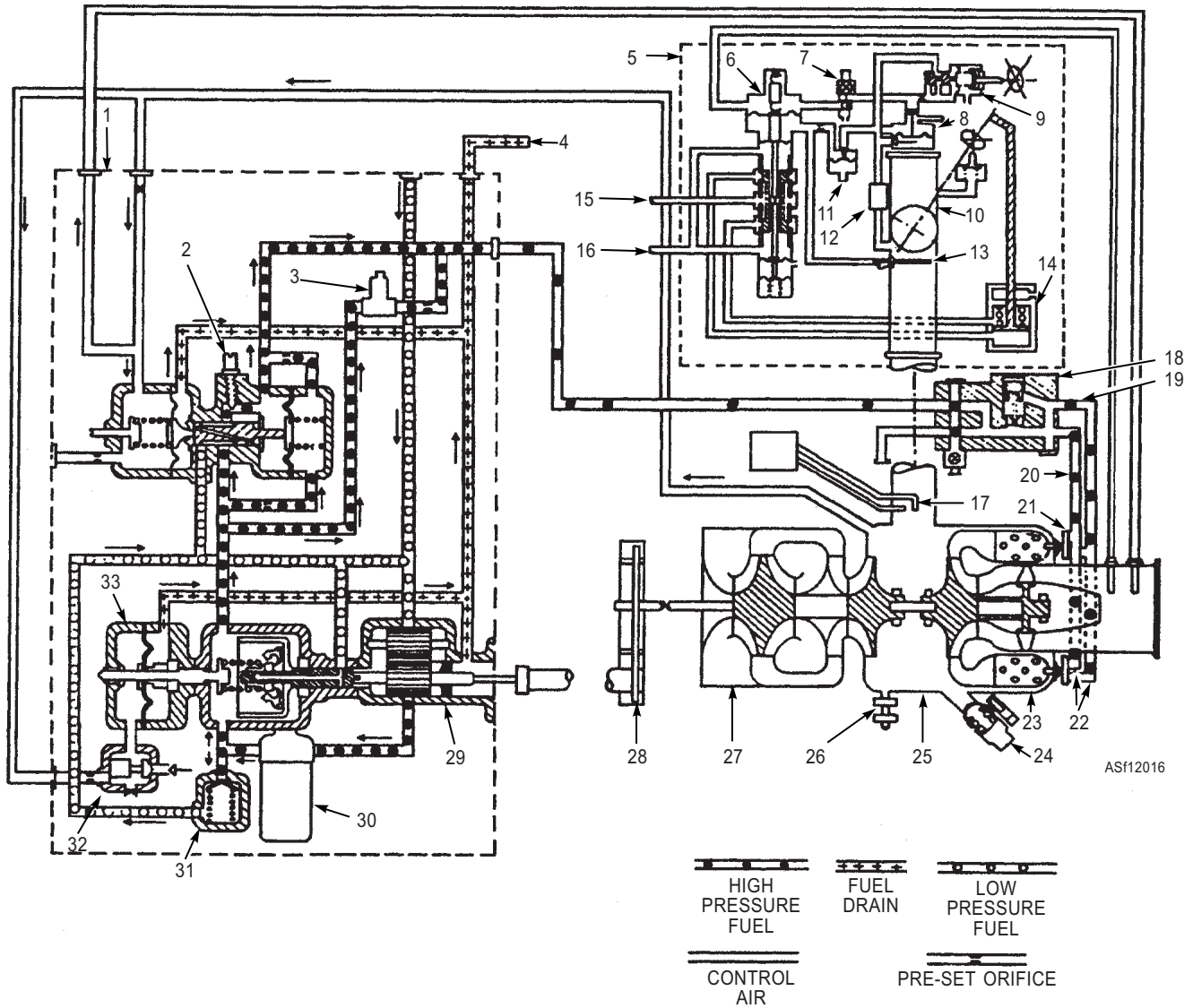

- | | | |
|------------------------------------|--------------------------------------|--------------------------------------|
| 1. Fuel control | 12. Control air filter | 23. Combustion chamber |
| 2. Fuel scheduling valve | 13. Inlet air thermostat | 24. Pneumatic air valve (scheduling) |
| 3. Auxiliary fuel solenoid valve | 14. Valve actuator | 25. Turbine section |
| 4. Fuel leakage drain | 15. Servo pressure oil in | 26. Turbine plenum drain valve |
| 5. Modulating and shutoff valve | 16. Servo scavenge oil out | 27. Compressor section |
| 6. Hydraulic piston servo assembly | 17. Pressure-differential probe | 28. Accessory drive section |
| 7. Valve actuating solenoid valve | 18. Shutoff and drain solenoid valve | 29. Fuel pump |
| 8. Rate head | 19. Secondary pressure fuel line | 30. Fuel filter |
| 9. Variable pressure regulator | 20. Primary pressure fuel line | 31. Relief valve |
| 10. Bleed-air outlet | 21. Fuel atomizer assembly | 32. Two speed valve |
| 11. Pressure regulator | 22. Fuel manifold | 33. Governor |

Figure 12-16.—Engine fuel and control air system and bleed-air system schematic for typical GTCP-100.

When the output air switch is selected for lower engine speed operation, the circuit to the air-pressure-ratio solenoid valve in the fuel control de-energizes to allow the solenoid to open and bleed off some of the control air acting on the mechanical governor diaphragm. This reduction in applied control air resets the mechanical governor's spring tension for a lower engine speed, preset at 80 percent by the low-speed adjustment screw.

Air System

The air system consists of bleed-air control components, surge control components, pneumatic control components, and the necessary interconnecting plumbing. The main component for bleed-air control is the modulating and shutoff valve (load control valve) (fig. 12-18), which incorporates within one unit a butterfly shutoff valve, fixed and variable pressure regulators, an inlet air thermostat, an

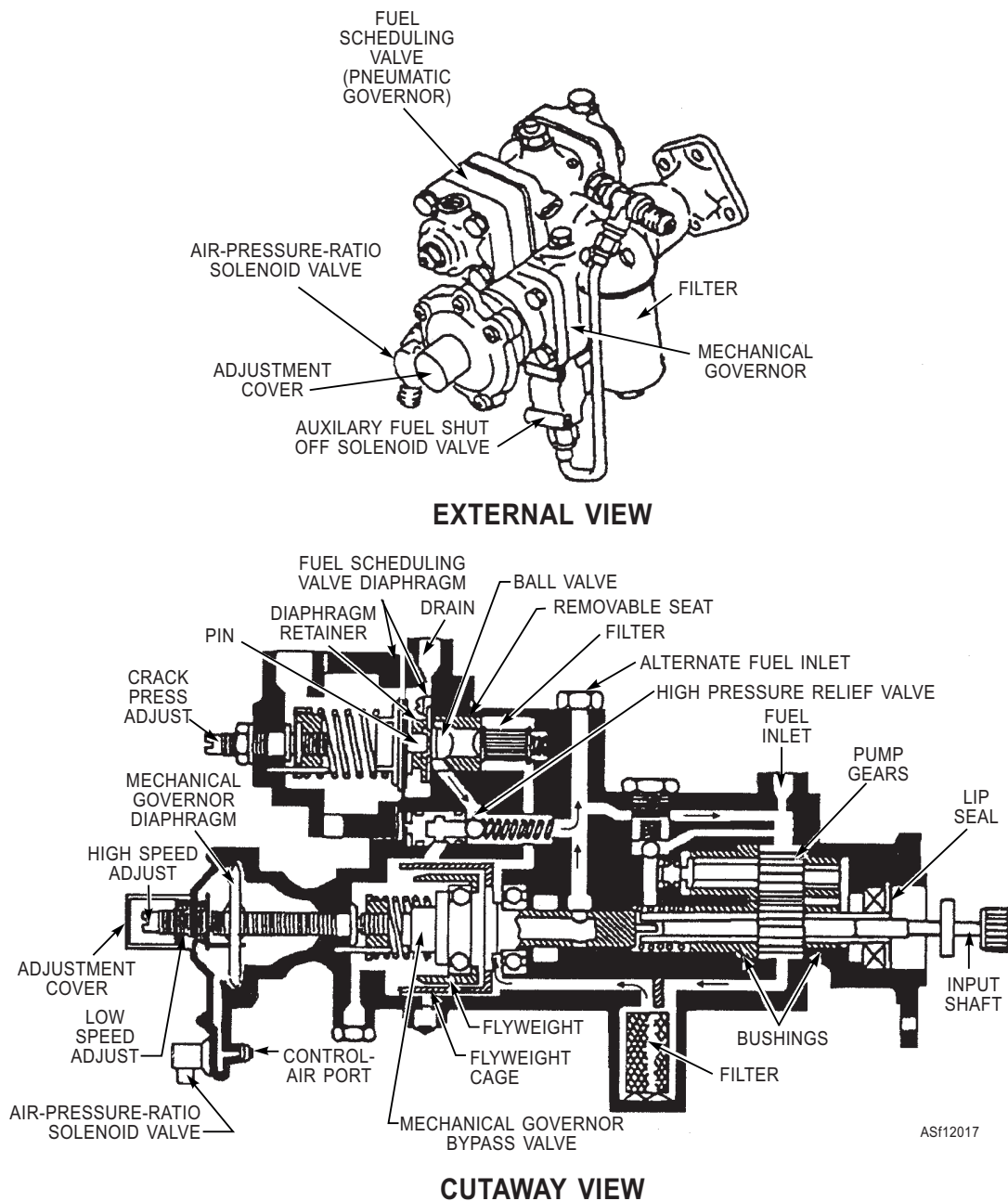

Figure 12-17.—Fuel control assembly.

actuating solenoid valve, and a hydraulic piston servo assembly. One other component of the bleed-air system is the load control thermostat located in the turbine exhaust duct.

The main component for surge control is the pneumatic shutoff valve (air scheduling valve), which incorporates a poppet valve, a spring-loaded piston, and a solenoid valve. Other components of the surge control system are a pressure-differential probe and a cutout switch, which is remotely mounted in the enclosure.

The bleed-air components function to provide modulation of bleed airflow while maintaining

constant shaft output speed under varying conditions of engine load, inlet temperature, and discharge temperature. Selection of the output air switch energizes the normally closed solenoid valve (fig. 12-18) that opens to bleed air to the servo valve. The hydraulic servo valve positions the butterfly through a crank, piston rod, and piston actuator. Modulation of the butterfly position is performed by the bleed action of the load control thermostat that bleeds air from the variable pressure regulator; modification of the load control thermostat action to accommodate variations in inlet air temperature is provided by action of the valve thermostat on the pressure regulator.

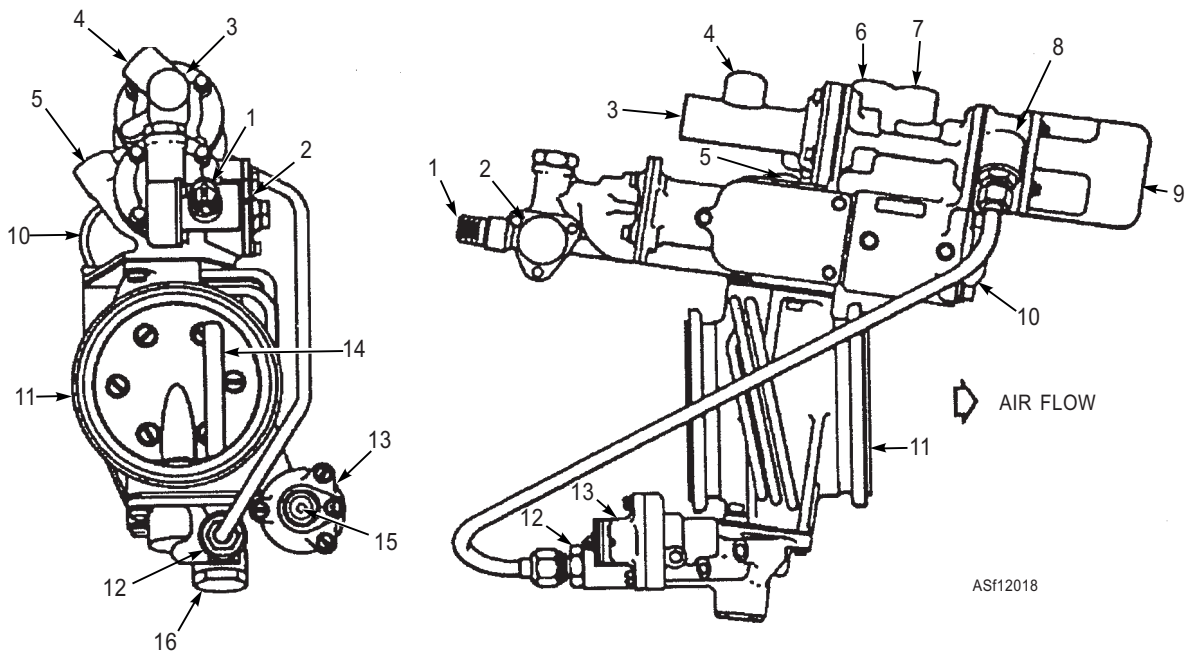

- | | |
|--|--|
| <ol style="list-style-type: none"> 1. Solenoid receptacle 2. Solenoid valve 3. Modulating valve spring tension adjusting cap 4. Exhaust thermostat boss 5. Drain boss 6. Oil out boss 7. Oil in boss 8. Capillary assembly | <ol style="list-style-type: none"> 9. Rate head 10. Servo assembly 11. Butterfly valve assembly 12. Filter assembly 13. Constant pressure regulating assembly 14. Thermostat assembly 15. Constant pressure regulator adjustment screw 16. Thermostat removal and test pressure plug |
|--|--|

Figure 12-18.—Modulating and shutoff valve.

The surge control components function to modulate the engine acceleration schedule and reduced speed schedule. Modulation of the engine acceleration schedule (rate) is accomplished by the action of the pneumatic shutoff valve when it is actuated by the centrifugal switch. This valve operates between 35 percent and 95 percent of engine rated speed and bleeds off turbine inlet air as required for smooth acceleration.

Modulation of the engine's reduced speed schedule is performed by the action of the pneumatic shutoff valve when it is actuated by the cutout switch. The circuit to the cutout switch energizes when the output air switch is selected for lower engine speed operation. The cutout switch actuates the pneumatic shutoff valve to bleed off excess compressed air until it is signaled by the pressure differential sensing probe.

The probe, located in the bleed-air flow, senses a pressure differential as the modulating and shutoff valve starts to open. This differential acts on the cutout switch diaphragm and opens the contacts, which, in turn, closes the pneumatic shutoff valve. A smooth transition occurs between the controlled opening speed of the modulating and shutoff valve and the closing of the pneumatic shutoff valve to prevent a

harsh surge of bleed air, which could damage aircraft starter shafts.

When the output air switch is placed in the "OFF" position, the modulating and shutoff valve closes, eliminating bleed air (and a pressure differential acting on the cutout switch). Hence, the cutout switch contacts close and re-actuates (opens) the pneumatic shutoff valve until the engine speed, again, increases above 95 percent (no-load condition).

MODULATING AND SHUTOFF VALVE.—The modulating and shutoff valve is the principal component of the bleed-air system. Bleed loading of the engine is accomplished by bleeding compressed air from the engine. This valve allows for air to be bled from the engine while maintaining governed speed for engine operation.

DUCT ASSEMBLIES.—Ducting is used to transport the air bled from the engine to the unit being serviced, normally an aircraft engine requiring air for starting.

INTERNAL DUCTING.—Ducting within the enclosure allows air discharged from the modulating and shutoff valve to reach the outer shell of the

enclosure, where a bleed-air hose is coupled to the internal ducting.

BLEED-AIR HOSE.—The pneumatic starter duct, also called the *bleed-air hose*, consists of a flexible duct, scuff cover, handling ring, bands, and an end fitting to connect the assembly from the air start unit to the aircraft. The bleed-air hose assembly is available in 30- and 60-foot lengths.

Inspection.—It is extremely important to regularly inspect bleed-air hose assemblies because a break or separation in the assembly can cause serious injury to personnel and damage to equipment. The duct should be visually inspected for damaged components, loose clamps, and air leaks. Dimensional inspections must also be performed to check for minimum length, number of splices, and the installation of the scuff cover. Refer to the maintenance manual for specific inspection points and dimensions.

Repair.—Repair of the pneumatic duct assembly is outlined specifically in the technical manual and should be adhered to when performing repairs. Particular attention should be directed to guidance on splicing the hose assembly.

Replace.—When repair of the duct assembly exceeds specific guidelines specified in the technical manual, replace it with a new assembly.

Lubrication System

The lubrication system consists of lubricating components and the necessary interconnecting plumbing (fig. 12-19). The main component of the system is the oil pump (fig. 12-20), which incorporates within one unit a gerotor-type pressure pump, three gerotor-type scavenge pumps, and an oil filter. Other components of the system are the cooling fan, oil temperature regulator assembly, oil cooler, and the oil tank assembly.

The system functions to supply pressurized and splash lubrication to the accessory drive gears, to the starter motor clutch, to the compressor rotating assembly bearings, and to the turbine rotating assembly bearings. The system also provides pressurized oil for operating the hydraulic servo assembly in the modulating and shutoff valve. The scavenge oil is pumped to the oil temperature regulator valve, where, depending on oil temperature, it is either passed directly into the oil tank or diverted through the oil cooler tubes, and then to the oil tank.

The air-driven, vane, axial cooling fan is connected by ducting to the oil temperature regulator assembly; it provides the necessary air to cool the return oil flowing through the cooler.

OIL TANK.—A rectangular, internally baffled container, the oil tank provides a reservoir for the lubrication system oil. Located behind an enclosure access panel, the oil tank is secured in place by steel straps. Oil is drawn from the outlet, near the tank bottom, by the engine-driven oil pump. Oil is returned to the tank by the engine-driven scavenge pump via the oil cooler assembly. A drain port with a removable plug is provided at the bottom of the tank and a filler neck and cap assembly with a dipstick are located on the side.

OIL PUMP.—Mounted to the accessory drive section, the oil pump is a rotary type pump that operates at 4,172 rpm (nominally). Replacement of the oil pump is described in the operation and maintenance manual. However, it is important to note that certain steps are particularly critical in the replacement of the oil pump. First, when installing the new oil pump, ensure that the drive gear engages with the drive gear in the accessory housing. Failure to do so could indicate oil pump failure when, in fact, the pump is not being driven. Damage may also occur to the pump.

It is also important to prime the oil pump prior to engine operation. This prevents air pockets from forming in the oil system and decreases the amount of time that the engine is rotated without positive oil flow or pressure.

OIL SCAVENGE PUMP.—The oil pump contains three scavenge oil elements that pump scavenge oil to the oil temperature regulator valve where, depending on temperature, it is passed through the oil cooler or bypassed directly to the oil tank.

OIL FILTER.—The oil pump has a replaceable filter to filter contaminants from the oil stream.

OIL COOLER ASSEMBLY.—The cooler assembly is a two-part unit that consists of the oil

WARNING

Lubricating oil, MIL-L-23699, contains materials hazardous to health and produces paralysis if swallowed. Prolonged contact may irritate skin, so wash your hands thoroughly after handling. Use in a well-ventilated area. Lubricating oil may burn if exposed to heat or flame.

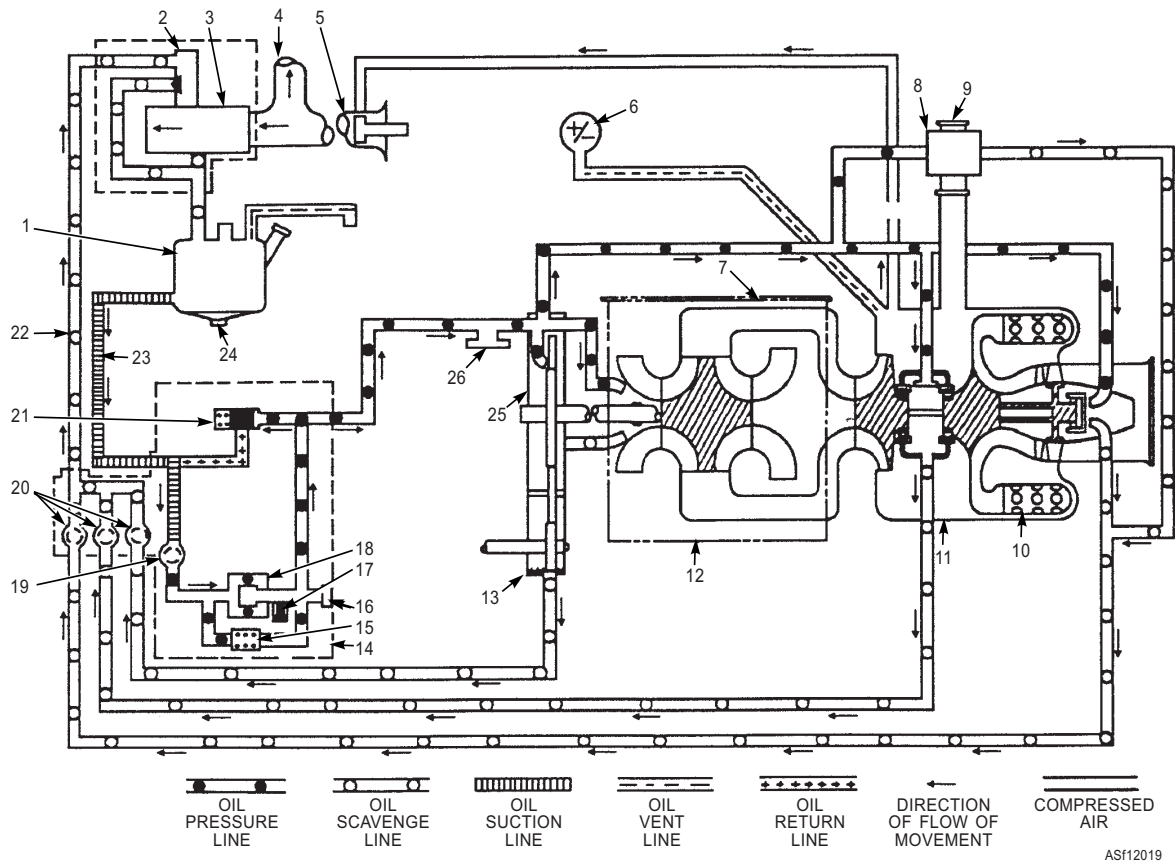

AS112019

- *1. Oil tank assembly
 - *2. Oil temperature regulator thermostatic bypass valve
 - *3. Oil temperature regulator oil cooler
 - *4. Cooling air duct
 - *5. Vane axial cooling fan
 - *6. Cavity pressure gauge
 - 7. Compressor air inlet
 - 8. Modulating and shutoff valve
 - 9. Bleed-air outlet duct
 - 10. Combustion area
 - 11. Turbine section
 - 12. Compressor section
 - 13. Screen
 - *14. Oil pump assembly
 - 15. Filter bypass valve
 - 16. Oil pressure gauge tap
 - *17. Thermoswitch
 - 18. Oil filter
 - 19. Oil pressure pump
 - 20. Oil scavenge pumps
 - 21. Relief valve
 - *22. Scavenge return line
 - *23. Oil pump inlet line
 - *24. Drain plug
 - 25. Accessory drive section
 - 26. Oil pressure switch
- *Enclosure furnished equipment

Figure 12-19.—Engine lubrication system schematic.

cooler and the thermostatic temperature control valve. The cooler assembly is a cylinder that contains a multitude of small tubes, which extend the full length of the cylinder. The tubes are supported by perforated end caps. Hot oil enters one end of the cylinder, flows around and between the tubes, and exits at the cylinder outlet. Heat imparted to the tubes is radiated to the ambient air passing through the tubes. The amount of hot oil passing through the cooler is regulated by the thermostatic temperature control valve.

THERMOSTATIC TEMPERATURE CONTROL VALVE.—The oil thermostatic temperature control valve assembly consists of an inlet valve, an outlet valve, and a relief valve. Attached to the oil cooler assembly, the control valve bypasses enough hot scavenge oil through the oil cooler to maintain oil temperature within safe operating limits. The inlet valve begins to open when oil temperature reaches operating temperature. Higher temperatures cause the valve to open further, allowing more oil to enter the cooler. The outlet valve opens to the extent necessary

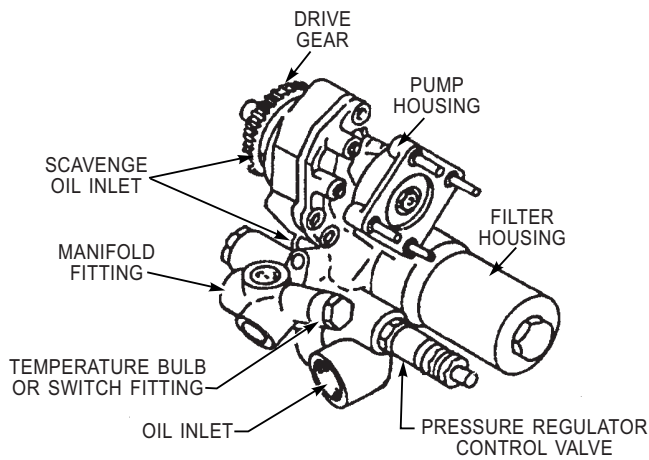

EXTERNAL VIEW

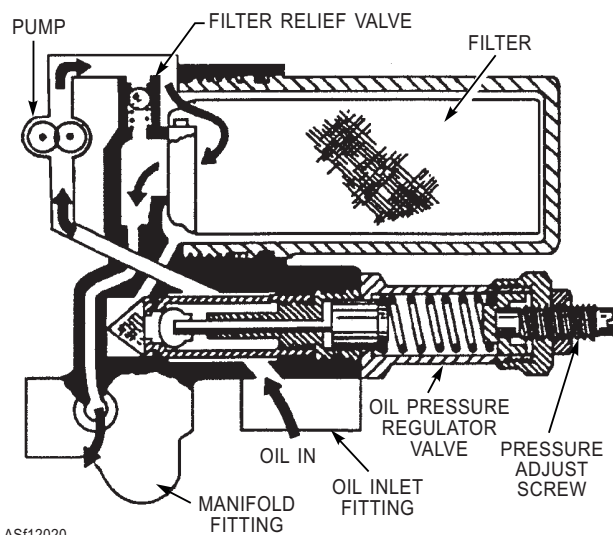

ASf12020

OIL PUMP SCHEMATIC

Figure 12-20.—Oil pump assembly.

to mix metered, cooled oil with hot oil, and to cool the hot oil to operating temperature. The relief valve allows oil to bypass the cooler if pressure increases due to a failed valve or clogged cooler.

OIL DRAIN PLUG.—The oil drain plug is located at the bottom of the oil tank. The plug allows the oil tank to be completely drained of all old or contaminated oil. This drain plug is accessible through an enclosure access door. It is important that you remember to replace the oil filter element after completely draining the oil tank and before reservicing the tank with fresh oil.

Electrical System

The electrical system consists of electrical components, wiring harness assemblies, and lead

assemblies, as well as any needed clamps, brackets, and mounting hardware. The main component of the system is the three-speed centrifugal switch (fig. 12-21). It contains three centrifugally actuated switches for controlling the sequence of engine operation. Other components of the system, shown in figure 12-22, are the electrical starter, the control relay, the ignition unit, the igniter plug, the thermocouple, the oil pressure switch, and the start counter.

The system provides the required electrical starting and control operations through the entire range of engine operation. A master switch supplies 24 volts of dc battery power to the engine electrical system. Upon actuation of the start switch, the electrical starter motor rotates the engine (through a sprague clutch) until the engine reaches 35 percent of the governed speed; at this time, the centrifugal switch cuts out the starter circuit.

The oil pressure switch contact sets close sequentially and activate the ignition unit. Then, the contacts actuate the fuel shutoff and drain solenoid valve and the start counter.

The ignition unit provides pulsed, high voltage to the igniter plug until the centrifugal switch cuts out the ignition circuit at 35 percent of governed speed; at this speed, combustion is self-sustaining. The load light is energized by the centrifugal switch at 95 percent of governed speed to indicate the engine is operating at sufficient speed to provide bleed air.

The centrifugal switch cuts out all circuits and shuts down the engine at 110 percent of engine governed speed by eliminating the ground to the electrical system holding coil within the control relay.

JET AIRCRAFT START UNIT, MODEL A/M47A-4

The Model A/M47A-4 jet aircraft start unit (shown in figs. 12-23 and 12-24) is a complete, self-contained unit that consists of a GTCP-100 gas turbine engine mounted in a flyaway assembly enclosed in a skid-mounted, weather-resistant enclosure. Some models of the A/M47A-4 are mounted on trailers for ease of movement from aircraft to aircraft or place to place. The A/M47A-4 supplies compressed air at two pressure ratios, 5:1 and 3.6:1, for aircraft engine starting and for ac and dc electrical power for operating aircraft with ac and dc electrical components. The A/M47A-4 is primarily a shore-based unit; however, some are used on carriers for maintenance of jet engines.

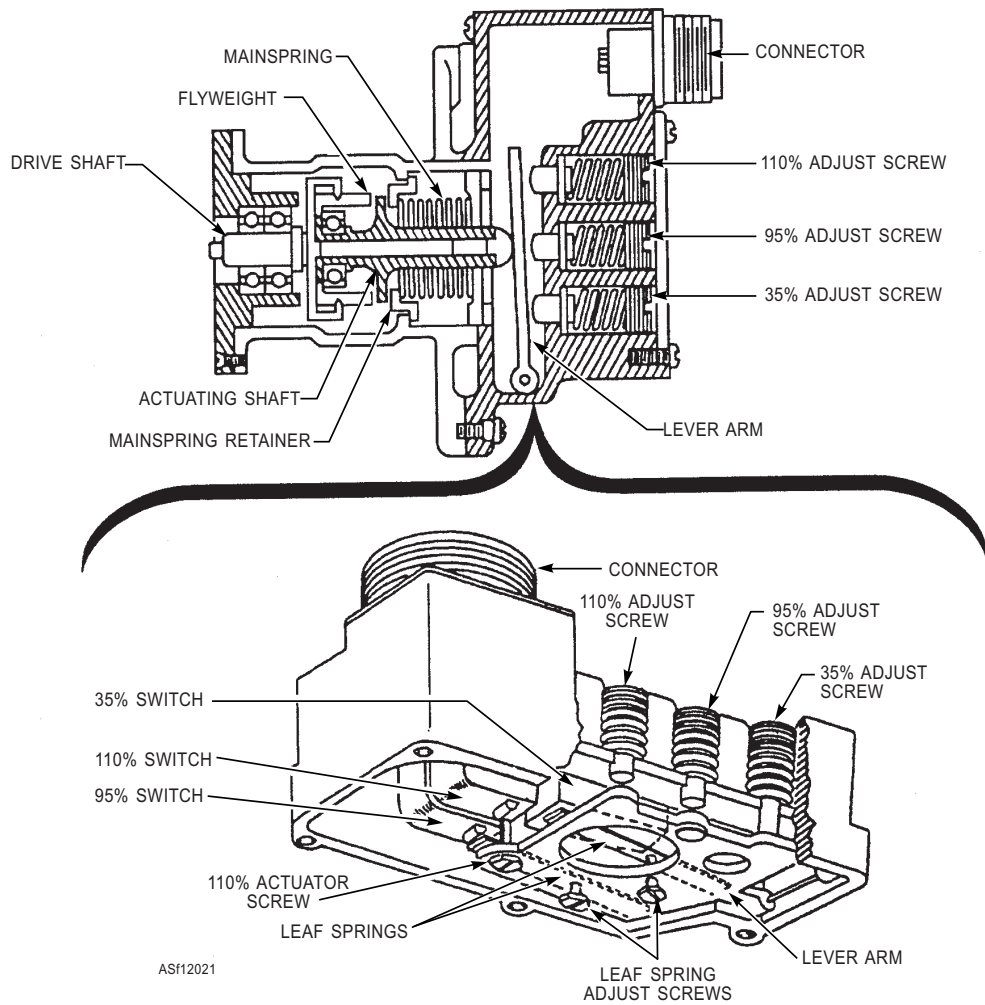

Figure 12-21.—Centrifugal switch assembly.

Q12-14. How many combustion chambers are on a GTCP-100 engine?

1. One
2. Two
3. Five
4. Six

Q12-15. The igniter plug is located in which of the combustion cap assemblies on the GTCP-100 engine?

1. No. 1
2. No. 2
3. No. 5
4. No. 6

Q12-16. What type of fuel pump is used on the GTCP-100 engine?

1. A gear type
2. A centrifugal type
3. A reciprocating type
4. A rotary type

Q12-17. What is a safety hazard associated with the lubricating oil MIL-L-23699?

1. It has an extremely low flashpoint
2. It can cause paralysis
3. It is very corrosive and can cause severe burns
4. It is a hazard to the environment if spilled on the ground

Q12-18. Which of the following components will shut the GTCP-100 engine down by eliminating the ground to the electrical system holding coil?

1. The low oil-pressure switch
2. The high engine-temperature switch
3. The overload switch
4. The 110-percent centrifugal switch

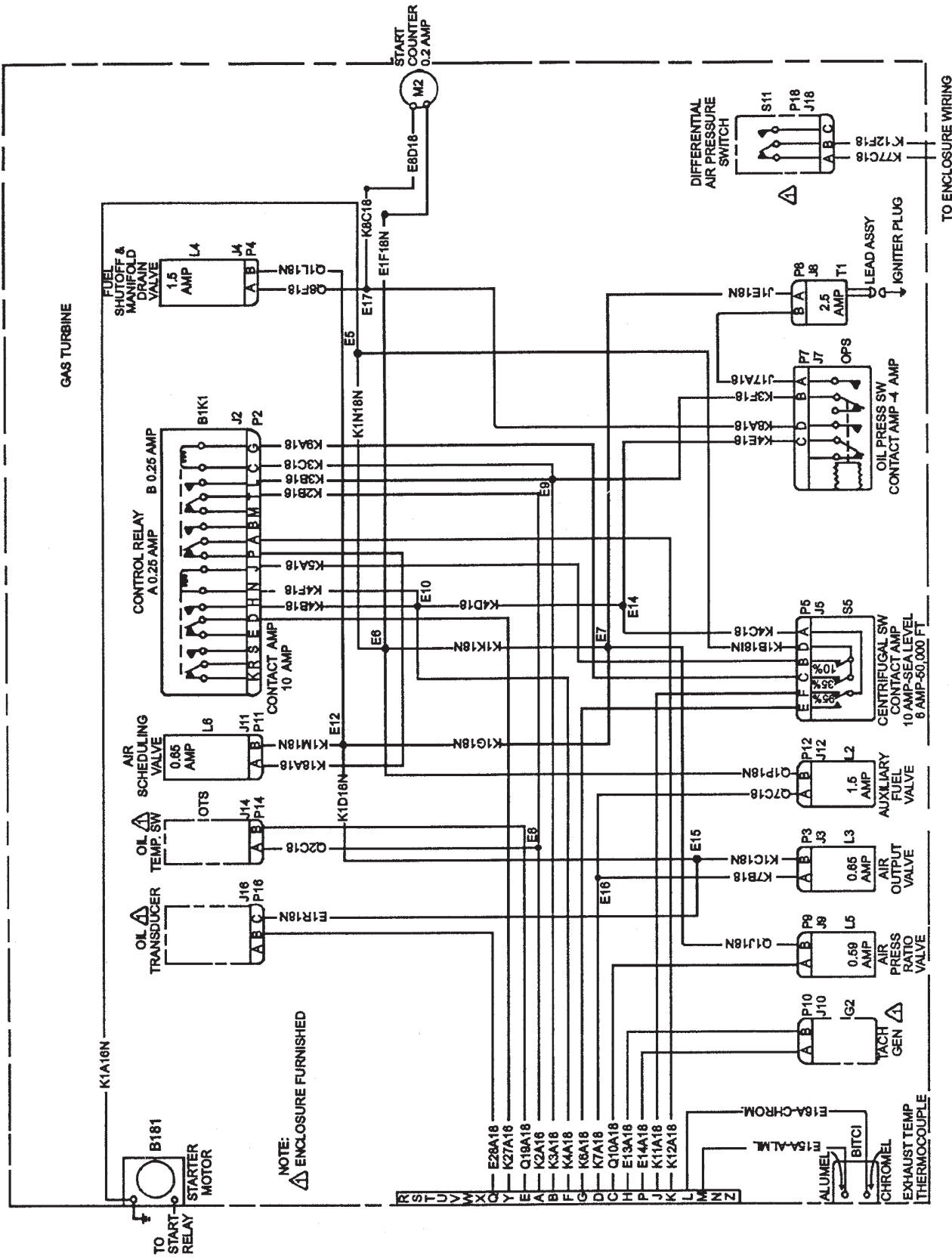

AS112022

Figure 12-22.—Engine wiring diagram.

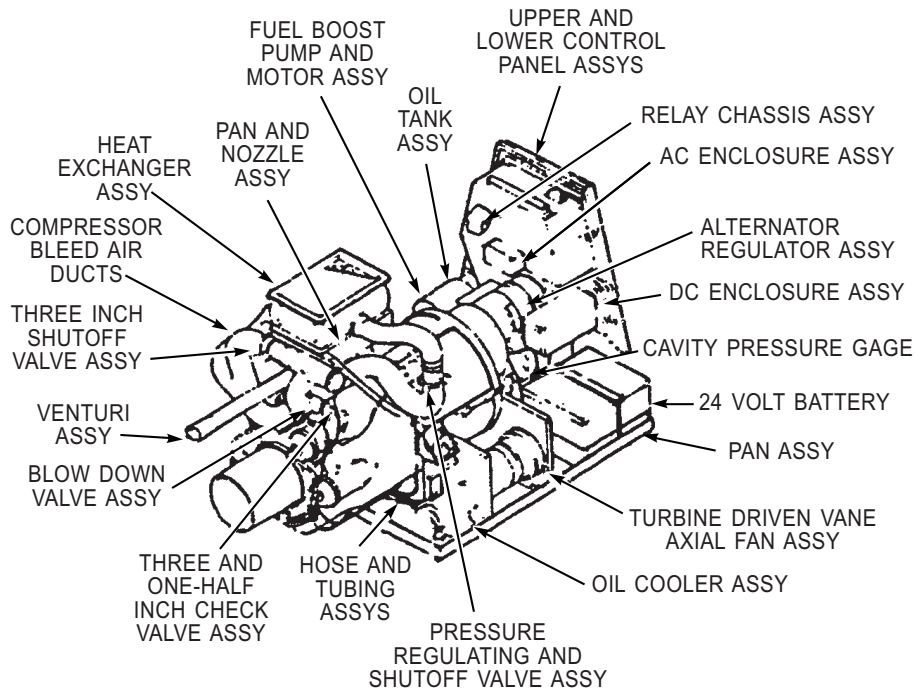

ASf12023

Figure 12-23.—A/M47A-4 flyaway assembly.

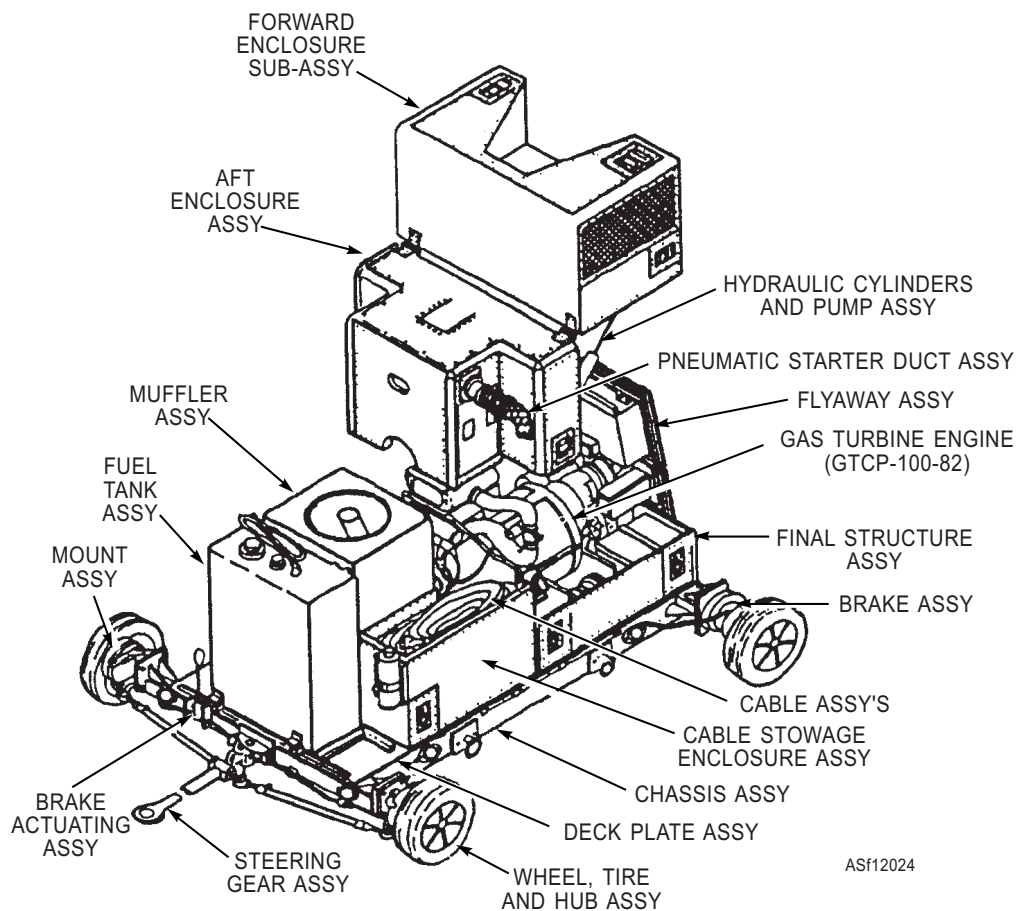

ASf12024

Figure 12-24.—Model A/M47A-4 compressor power unit.

MAINTENANCE OF GAS TURBINE COMPRESSORS

LEARNING OBJECTIVE: Identify procedures for performing maintenance on gas turbine compressors.

Gas turbine compressors are precision units that require special tools and testing devices, which are not available at the lower levels of maintenance. There are also special requirements as to cleanliness and availability of power. For these reasons, maintenance is normally performed at intermediate-level maintenance activities.

Maintenance of the engine often requires the use of a hoist, or some type of chain fall, to lift the engine in and out of its enclosure or to place it in a shipping container. As there is no specific hoisting device named in the instructions given in the MRCs, the crew leader is normally responsible for selecting a type that allows the maintenance to be performed with maximum safety of the crew. Also, the special lifting adapter, which is supplied with the unit, may not be replaced with a substitute. These adapters are made for use with the specific unit, and substituting an improper adapter can cause imbalance during hoisting, leading to the unit being dropped. This will certainly damage the unit, and may cause injury to the crew.

Removal and installation of gas turbine compressors demand an alert crew. Each step of the procedure must be performed in strict accordance with the instructions provided in the appropriate manual or MRCs for the type of unit being maintained.

REMOVING AND REPLACING GAS TURBINE ENGINES

Replacement of gas turbine engine components does not necessarily require the removal of the engine from the enclosure. Many components are accessible through access panels and doors. However, many circumstances require the removal of the gas turbine engine from the unit.

Access to the gas turbine engine for removal can be obtained by first removing the enclosure from the tractor (if so mounted). Ensure the enclosure is placed on a suitable support fixture to provide access to the bottom of the unit.

After following the steps in the appropriate operation and maintenance manual for disconnecting enclosure ducting, air, fuel, and oil hose assemblies, as well as all electrical connections, attach the engine

lifting adapter to the top of the engine. Using an overhead crane or hoist, carefully raise the engine enough to remove the slack from the linkage. Then, remove the engine attaching bolts from the engine mounting pads, attach maintenance stand mounts, and place the engine in a maintenance stand.

Replace the gas turbine engine in the reverse order of the procedure you used to remove it from the enclosure. Ensure that new gaskets and packing are used at all connections.

GENERAL CLEANING PROCEDURES

Electrical parts may be cleaned with a soft cloth dampened in an approved solvent. A clean, dry, soft-bristle brush may also be used. When using a solvent, make sure you keep the area well ventilated and avoid breathing the fumes. Do not use solvents in the vicinity of open flames. Metal parts and tube assemblies may be cleaned by dipping the parts in solvent, and then drying them thoroughly with clean compressed air. Air, fuel, or oil passages in removed components may be blown clean with compressed air, but you must take care to direct the air blast away from personnel and equipment.

To remove hard carbon deposits from components, use one of the approved decarbonizing agents. Consult the appropriate maintenance instruction. Use of sandpaper, wire bristle brushes, or scraping tools is strictly prohibited. When the clean parts are not used at once, they should be placed in clear plastic bags to prevent corrosion and contamination.

MINOR REPAIR AND ADJUSTMENT

Most repairs to the gas turbine compressor involve the removal of major components. This consists principally of disconnecting electrical and tubing connectors, removing attached hardware, and withdrawing the component from the unit. All removals should be done in keeping with good shop practices.

Some parts require only minor repair, which may consist of inspection, repair, and cleaning faulty components. Consult applicable maintenance manuals for procedures pertaining to adjustments and repair.

Q12-19. What is the recommended cleaning method for electrical parts?

- 1. Use a soft cloth and cleaning solvent*
- 2. Use a wire brush*
- 3. Use sandpaper*
- 4. Use a scraping tool on heavy buildup*

Q12-20. What is the recommended cleaning method for removing hard carbon deposits?

1. Use a light grit sandpaper
2. Use a wire bristle brush
3. Use a decarbonizing solvent
4. Use a scraping tool

TROUBLESHOOTING

LEARNING OBJECTIVE: Identify procedures for inspecting, testing, and troubleshooting GTC electrical, fuel, bleed air, and lubrication system components.

At the intermediate maintenance level, you may expect to be part of a troubleshooting/maintenance crew, or perhaps even the supervisor. When a malfunctioning unit is received, a troubleshooting crew is assigned to locate the trouble, make the necessary repairs, and return the equipment to an operational status.

A guide to common engine malfunctions, their probable causes, and appropriate remedies is provided in the maintenance section of the applicable equipment

manual. The tables in the manual do not cover all of the possible malfunctions, but should be used as a guide when performing corrective maintenance.

The appropriate portion of the maintenance section is referenced when specific step-by-step instructions are to be followed.

ENCLOSURE TROUBLESHOOTING

Table 12-1 outlines a systematic approach to maintenance. You should note that it is very important that you understand the relationship between the engine and its enclosure and how they interact. You must also know the purpose of each system component before you can systematically analyze the symptoms to determine the most likely cause of the problem.

Only those components that are malfunctioning should be changed. Do not practice **shot-gunning**, which is the removing and replacing of components in the order of their availability or ease of installation, regardless of their likelihood of being faulty. Shot-gunning is a waste of time, and eventually establishes a large inventory of illegal spare parts.

Table 12-1.—Malfunction Correction Procedures

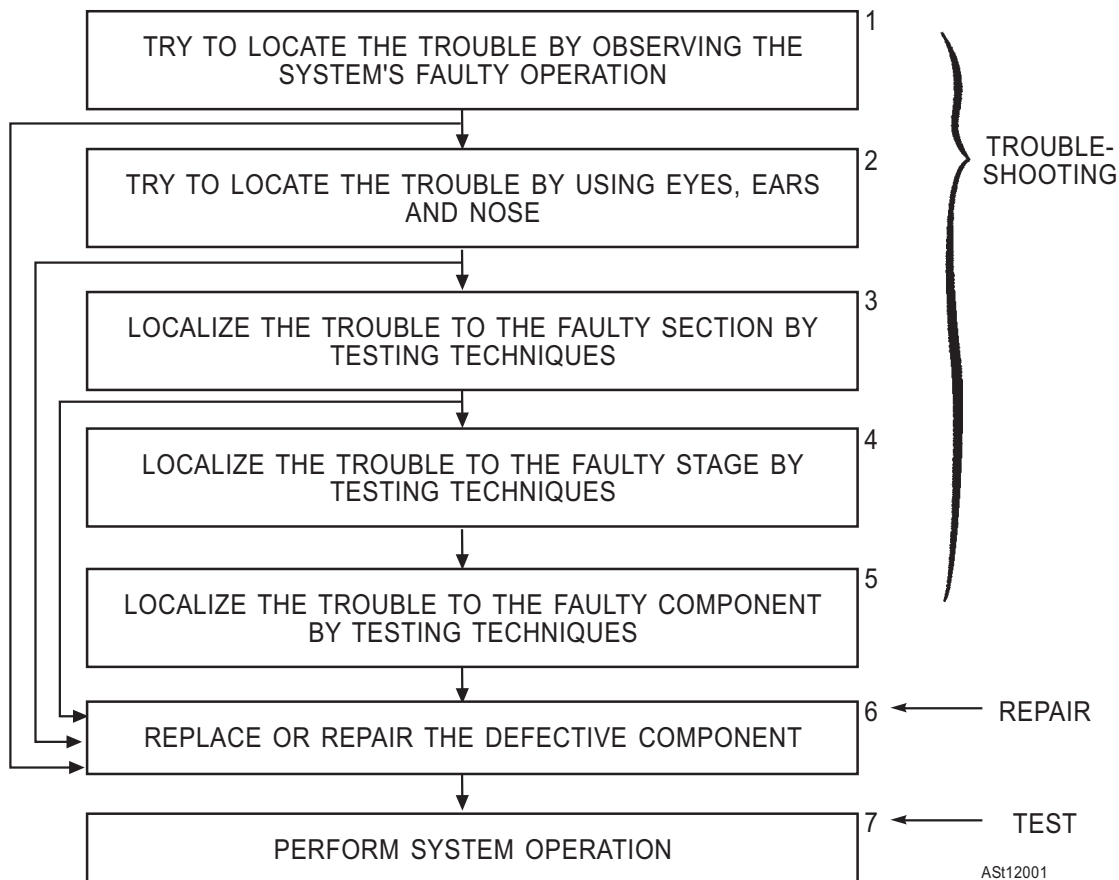

Keep in mind two very important troubleshooting commandments:

- Components are changed not as a means of troubleshooting but as a result of troubleshooting.
- Locate and correct the problem; don't just treat the symptoms.

The following discussion relates to troubleshooting on the basis of system knowledge and analysis.

No Response When the Start Switch Is Activated

Be sure the recommended starting procedures are followed when trying to start the unit. The start relay is a heavy-duty relay and makes a relatively loud sound when energized. Listen for the sound of the relay and starter motor while actuating the start switch. If the relay "clicks" but the starter is silent, the starter or a current limiter relay coil in the starter relay is faulty. If the starter runs but the turbine is not turning, remove the starter and inspect the clutch. If the starter clutch is found to be in order, inspect for a sheared pinion drive shaft between the accessory section and the compressor section. This can be checked by rotating the turbine axial wheel at the exhaust outlet while observing gear movement through the starter mounting hole. If the gears do not rotate with the turbine wheel, the engine must be disassembled and repaired by an authorized repair activity.

If the starter relay does not "click," verify that all switches are in their proper position, in proper sequence, at the proper time. If all switches are correct, an electrical control component or circuit is defective. Check the start switch, fuses or circuit breakers, turbine inlet door switch, air select (output air) switch, pilot transfer switch, enclosure cannon plugs, and wiring.

Starter Turns the Turbine But There Is No Light-Off (Combustion)

Listen to the unit's motoring action. Screeching or thumping sounds may indicate internal bearing, compressor, or turbine wheel and seal failures. These affect the starter's ability to turn the engine fast enough for ignition (insufficient oil pressure). Also, a weak battery may be at fault. If the battery is sufficiently charged and no rubbing sounds are heard, listen near the combustion chamber for the "cracking" sound of

the igniter plug. If the igniter is not heard, stop the motoring and check the turbine plenum drain for the presence of fuel. If some fuel comes from the drain, the ignition circuit is likely to be faulty, or carbon has fouled the igniter plug.

The ignition circuit electrical check includes the igniter plug, ignition unit, leads, oil pressure switch, and the 35-percent switch. If no fuel comes from the drain and there are no igniter sounds, the fault is probably something common to both fuel and ignition—the two-stage oil pressure switch. Remember, this switch operates on oil pressure; therefore, the oil pressure should be checked before changing the switch.

If igniter sounds can be heard while the unit is motoring, and excessive fuel runs out the plenum drain when the unit is shut down, the fuel flow divider (within the fuel shutoff and drain solenoid valve) should be checked. This can be done by disconnecting the secondary fuel manifold at the valve and installing a hose from the port to a catch bucket. Disconnect the ignition unit and motor the engine. A slight amount of fuel should leak from the hose. If a continual flow is noted, the flow divider is leaking within the fuel shutoff and drain solenoid valve and allowing too much fuel into the combustion chambers. This causes an overly rich mixture, which prevents combustion. If the valve is operating properly, check the auxiliary fuel shutoff solenoid valve at the fuel control for internal leakage.

If no fuel drains from the fuel shutoff and drain solenoid valve when power is secured, check the solenoid valve for proper operation. This can be done by disconnecting the fuel line coming from the fuel control to the valve and checking the cracking pressure. If the cracking pressure is within limits, check the electrical circuitry to the valve via the oil pressure switch, control relay, and the 110-percent contacts in the centrifugal switch. If the electrical circuitry is in order, replace the fuel shutoff and drain solenoid valve.

Unit Flames or Booms on Light-Off

A booming light off or flames emitted from the exhaust are caused by excessive fuel flow into the combustion chamber at light off. This condition, known as a *hot start*, may also be caused from admission of fuel into the combustion chamber before there is sufficient airflow for combustion. Premature admission of fuel can result from a leaking fuel shutoff

and drain solenoid valve. This would probably show up in leaking fuel from the plenum drain during deceleration when the engine is stopped. To check the solenoid, remove the electrical connector from the oil pressure switch, remove the fuel line from the fuel atomizer, and place the end of the line in a bucket. Motor the unit and if the solenoid valve is OK, no fuel should flow through the line.

Premature opening of the fuel shutoff and drain solenoid valve causes fuel to enter the combustion chamber before there is sufficient airflow for combustion. This causes the fuel to puddle. Then, when light off (combustion) finally occurs, a noticeable flame shoots out the exhaust until the excess fuel burns off. This fault can be caused by a faulty oil-pressure switch. To check the switch, listen for the sound of the igniter plug when the start switch is actuated. Remember, the ignition unit and fuel shutoff and drain solenoid valve are sequentially activated at 2.5 to 3.5 psig (about 10-percent engine rpm). If the igniter can be heard as soon as the start switch is actuated, the oil-pressure switch is bad.

If fuel and ignition appear to be sequenced properly by the oil-pressure switch, stop the unit and disconnect the fuel line from the fuel atomizer. Connect a pressure gauge to the line, motor the unit, and read the “cracking” pressure. If the pressure is higher than specification, the high pressure is causing too much fuel flow through the fuel atomizer by prematurely opening its flow divider valve. If “cracking” pressure is normal, the fuel atomizer is probably faulty. During the check and repair of the fuel atomizer, check the combustion liner for deformation, excessive carbon, or cracks that may affect the unit’s operational efficiency.

Engine Lights Off But Will Not Accelerate

The cause of an engine not accelerating may be too little turbine power being developed to meet the engine’s requirements. The power requirements are reflected by the turbine discharge temperature (TDT). Therefore, if the motoring engine “hangs” during acceleration and the turbine temperature runs high (close to the setting of the acceleration and overtemperature thermostat), the engine is requiring more than a normal amount of power from the turbine.

Feel around the turbine plenum, tail pipe, and combustion chamber for large air leaks. Check the modulating and shutoff valve to ensure that it is not stuck open. If no problems are found in these areas,

stop the unit and listen for deceleration noises. Noises indicate that bearings, seals, or rotating components may be failing, causing excessive drag on the unit.

Smooth deceleration indicates no excessive drag on the unit. Therefore, the turbine is not converting the energy it receives properly or its airflow is obstructed. Check the air intake and exhaust ducting. After the unit cools, check the turbine wheel and flame tube for damage and excessive carbon.

If the temperature is low and the unit fails to accelerate, the fuel and control air pressure should be observed. The engine can accelerate only if the control air pressure acts on the fuel scheduling valve’s diaphragm, and calls for increasing fuel flow to keep pace with increasing airflow. If the control air pressure system develops any appreciable leakage, fuel pressure will be too low to allow the unit to reach full speed. If the air pressure is low or fails to rise with engine speed, check for leaks at the inlet air orifice on the compressor housing, the control air filter, all of the control air plumbing, and acceleration and overtemperature thermostat. You should also check the diaphragms of the fuel scheduling valve, the mechanical governor, and the air-pressure-ratio solenoid valve.

To check the mechanical governor diaphragm and the air-pressure-ratio solenoid valve, observe the high-speed adjustment screw on the fuel control while disconnecting the air-pressure-ratio solenoid valve. The adjustment screw should extend outward from the housing when the plug is disconnected and retract into the fuel control when the electrical plug is reconnected. If the adjustment screw retracts, the diaphragm and valve are working.

If no leaks are discovered and the air-pressure-ratio solenoid valve and diaphragm are operating, the acceleration and overtemperature thermostat could be bleeding off too soon (set too low). The thermostat can be checked by using the air control valve and air gauge assembly feature incorporated in the gas turbine engine analyzer (described later in this text). Disconnect the control air line from the fuel control to the thermostat and install the analyzer’s air control assembly feature in-line. Run the turbine unit with the air control valve closed and observe the unit’s TDT and the analyzer’s air gauge. If the analyzer gauge indicates a low air pressure, the unit has a control air leak; if the unit accelerates to governed speed, the thermostat is faulty and must be replaced or reset. If the unit has no air leaks, the thermostats check good, and it has sufficient fuel pressure but still does not accelerate

to full speed, the fuel is probably not flowing properly through the fuel atomizers. Check the atomizer screens and discharge patterns for foreign contamination or a carbon buildup on the atomizer tip.

Engine Shuts Down Intermittently For No Apparent Reason

The engine stops any time its fuel supply is interrupted long enough for the residual flame in the combustion chamber to go out. Poor electrical contact in the oil pressure switch can cause cycling of the fuel solenoid valve, thus interrupting fuel flow to the combustion chambers. Also, bouncing contacts in the 110-percent switch (overspeed) can cause cycling of the fuel shutoff and drain solenoid valve and still leave the electrical system holding coil energized. If shutdown occurs from any of these conditions, fuel will continue to be atomized into the combustion chamber during deceleration of the unit and a “fog” of unburned fuel may be emitted from the turbine exhaust.

If no evidence of fogging is seen during deceleration following an unscheduled shutdown, it is likely that the electrical controls have been de-energized and that the fuel shutoff and drain solenoid valve is closed. The 110-percent switch should be suspected now, as it may be set too low.

A sharp rap on the switch housing assembly with the plastic handle of a screwdriver while the unit is running may be tried to check the 110-percent switch. If the “rap” causes the contacts to open and shut down the engine, it is obvious the switch is off. If the unit does not stop, check the main electrical control relay for intermittent operation.

Excessive Speed (RPM) Droop When Load is Applied

Normally, the speed need not decrease more than 2 percent to provide enough signal for the fuel control mechanical governor to produce sufficient fuel pressure to force the required flow through the fuel atomizer for full load. Excessive droop upon load application is a result of the fuel system’s failure to provide the increased pressure required, or the inability of the turbine to convert the power that it receives efficiently.

If this condition occurs, make the following checks. Check to see if the boost pump is operating properly. Check to see if the primary and secondary fuel filters are clogged or collapsed. Check to see if the

acceleration and overtemperature thermostat is set too low or the load control thermostat is set too high. Check the auxiliary fuel shutoff valve. See if the pneumatic shutoff valve is stuck open. Check the control air pressure plumbing and connections for leaks. All of these conditions can affect the fuel control governor’s ability to provide the proper fuel pressure under load. If all components mentioned are within specification, replace the fuel control.

In rare circumstances, too much droop could be the result of more applied load than the unit was designed to handle or an internal mechanical malfunction, such as rubbing parts or defective bearings.

TROUBLESHOOTING AND MAINTENANCE AIDS

The engine and its components can almost always be checked without removal from the service installation (skid, trailer, enclosure, etc.) by using a special test panel, such as the UPUA4-1 gas turbine engine analyzer, to provide the necessary controls and instrumentations. If the engine is being test run outside the service installation, a special test stand, such as the UTTS-1-7 test stand, is used.

Gas Turbine Engine Test Stand

The UTTS-1-7 (fig. 12-25) is a universal test stand for checking gas turbine engines normally found in support equipment. The test stand provides engine support, a source of electrical power, fuel, and oil. The gas turbine engine analyzer must be used with this test stand to provide the necessary controls and test instrumentation. The analyzer is shown installed on the test stand in figure 12-25.

Because the test stand is adaptable to many different engines, it may be necessary to procure adapter assemblies (special tools) required for mounting a specific engine into the test stand. The technical manual for the test stand lists all of the required parts, plus the instructions for mounting the engine in the stand.

Gas Turbine Engine Maintenance Stand

The 281270-0-3 gas turbine engine portable maintenance stand (fig. 12-26) is used when the engine is removed from the service installation and components are removed for replacement of the engine or for aiding periodic maintenance. This maintenance stand is well suited for the shipboard environment

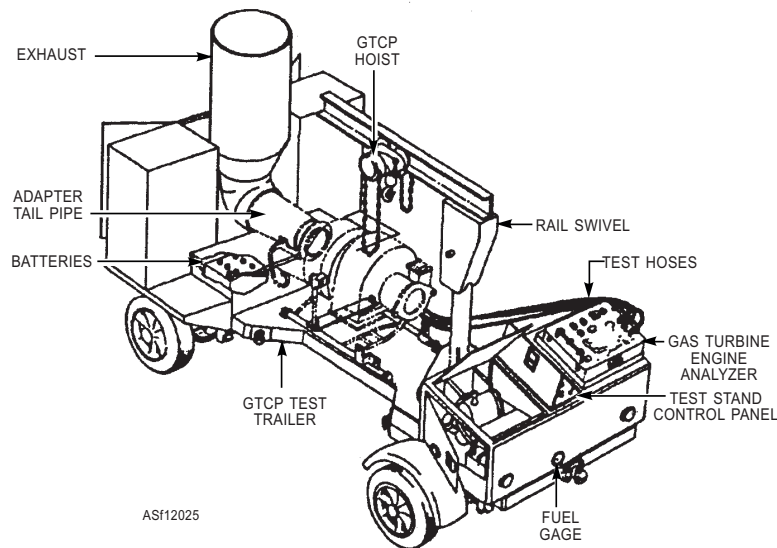

Figure 12-25.—Gas turbine engine test stand.

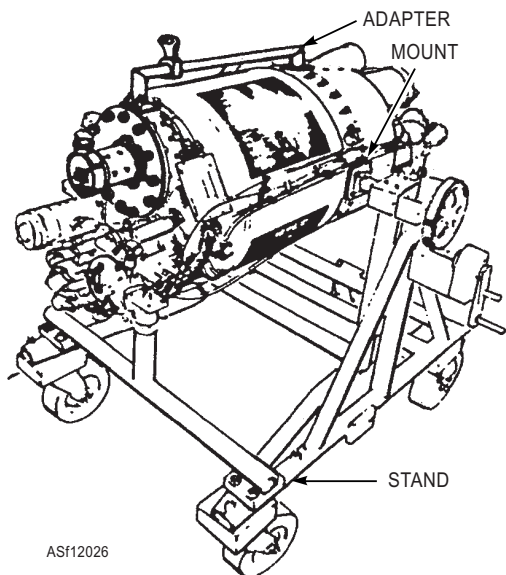

Figure 12-26.—Engine mounted on 281270-0-3 portable maintenance stand.

where limited space prohibits the use of the universal test stand. This stand also uses the mounting adapters noted earlier in our discussion of the gas turbine engine test stand.

CAUTION

Prior to an engine operating test run, ensure that the engine is securely mounted in its enclosure or a test stand that provides adequate instrumentation to indicate operating conditions. Check all plumbing and electrical wiring for routing and security. Check the fuel and oil tanks, and fill, if necessary. Ensure that all test setup switches and valves are placed in the proper positions.

Gas Turbine Engine Analyzer

The UPUA4-1 gas turbine engine analyzer (fig. 12-27) is a lightweight, portable testing unit. The analyzer instrumentation is attached to panels, which are mounted in a case. The cover of the case contains storage space for the analyzer cables and a very sensitive pressure gauge. Attached to the cover is a schematic wiring diagram and a speed conversion chart to convert tachometer rpm indications to actual engine rpm for the different engines that can be tested.

The analyzer incorporates an electrical system with associated meters and indicators. Fuel, oil, and pneumatic systems with associated gauges and controls for checking and controlling performance of gas turbine units are also provided.

The analyzer should be used only by personnel thoroughly trained in its use and who are familiar with the analyzer's technical manual, NAVAIR 19-105BC-1. Personnel should also be familiar with the use of common electrical test equipment. This type of background is required to accurately analyze the information.

A good working knowledge of the electrical, fuel, oil, and pneumatic systems and components for the particular gas turbine engine being tested is a prerequisite for satisfactory use of the analyzer and correct interpretation of results. Constant reference should be made to the applicable technical manual for electrical and pneumatic schematics and engine performance requirements for the engine being tested.

The analyzer may be used while the engine is installed in its service installation; the battery of the

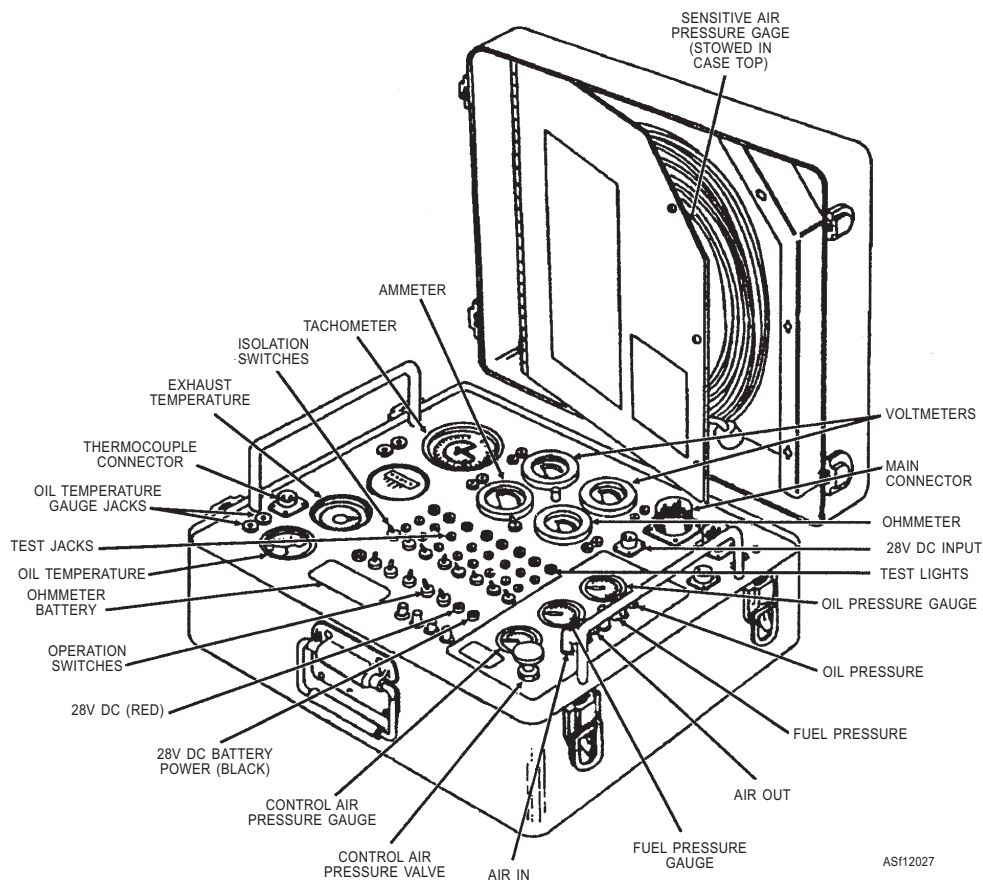

Figure 12-27.—Gas turbine engine analyzer.

service installation provides the electrical power necessary for the proper test functions of the analyzer. Figure 12-28 is an illustration of an analyzer being used to test an engine while it is installed in the enclosure. As noted earlier, the analyzer may also be used with the engine installed in a test stand (fig. 12-29). The test stand supplies the fuel, oil, and electrical power for both testing and operating the engine.

The only required maintenance for the analyzer is a periodic/calendar inspection. A preoperational inspection is performed on the analyzer prior to each use, and a calendar inspection is performed every 6 months. The calibration of gauges, meters, indicators, etc., must be performed every 90 days or when repaired, replaced, or when validity is questionable.

The analyzer may be used for measurement of turbine unit speeds, temperatures, pressures, output frequencies, and electrical circuit components. The

analyzer may also be used for monitoring the turbine unit during operation and for functional check of engine performance by controlling the load. It is also used for static checks of engine components (such as powering the fuel solenoid valve without the engine operating) and to motor the engine for preservation and depreservation.

The analyzer depends on electrical, fuel, oil, and pneumatic systems connected to the engine through electrical cables, fuel, oil, and air pressure lines.

ELECTRICAL SYSTEMS.—The analyzer's electrical system provides components for measuring turbine unit speed, exhaust temperature, and oil temperature. It also provides components for measuring engine-driven ac generator frequency, electrical component resistance, current, and voltage. Figure 12-30 shows a schematic wiring diagram of the UPUA4-1 analyzer.

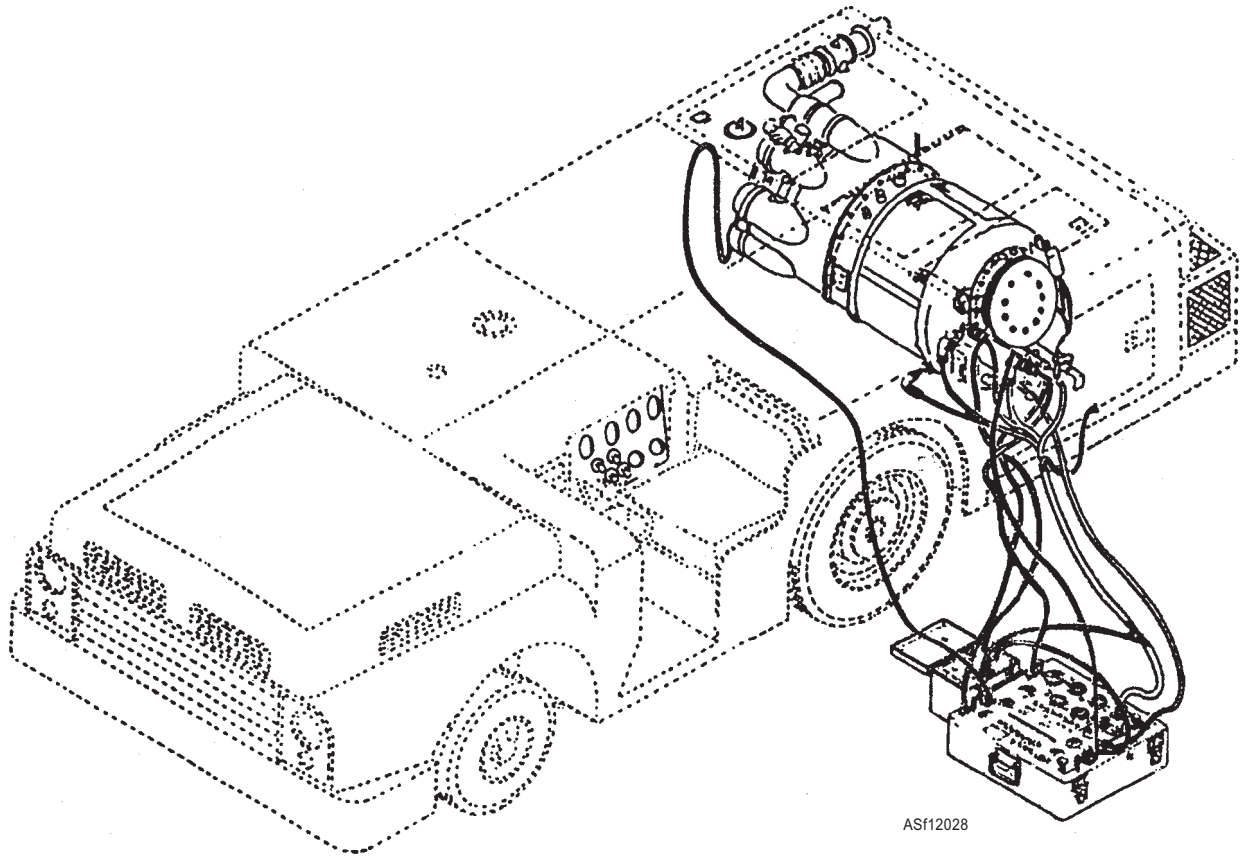

ASf12028

Figure 12-28.—Analyzer connected to engine while in its enclosure.

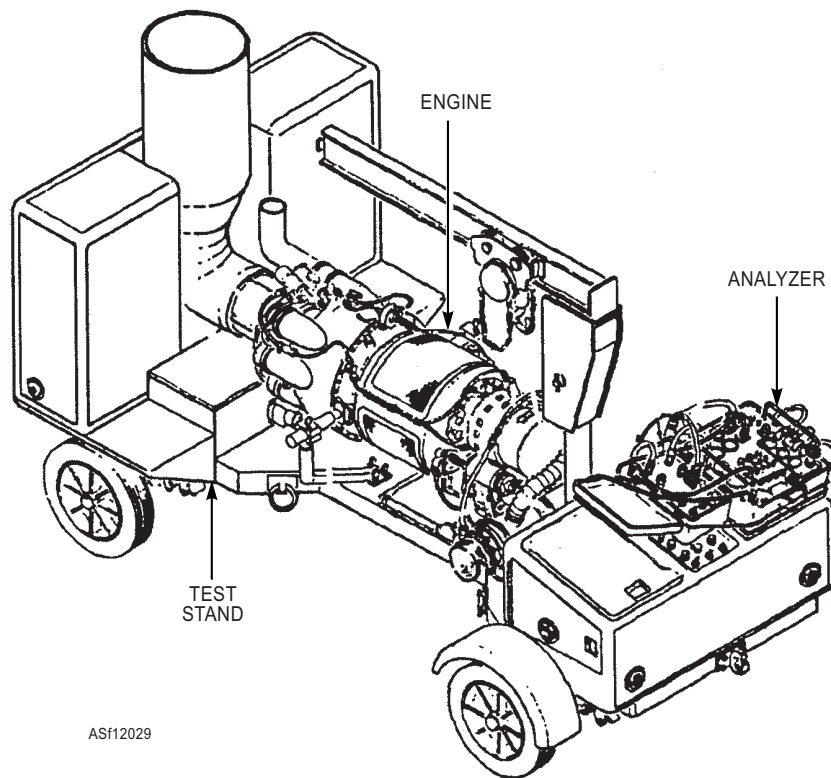

ASf12029

Figure 12-29.—Analyzer connected to engine installed in test stand.

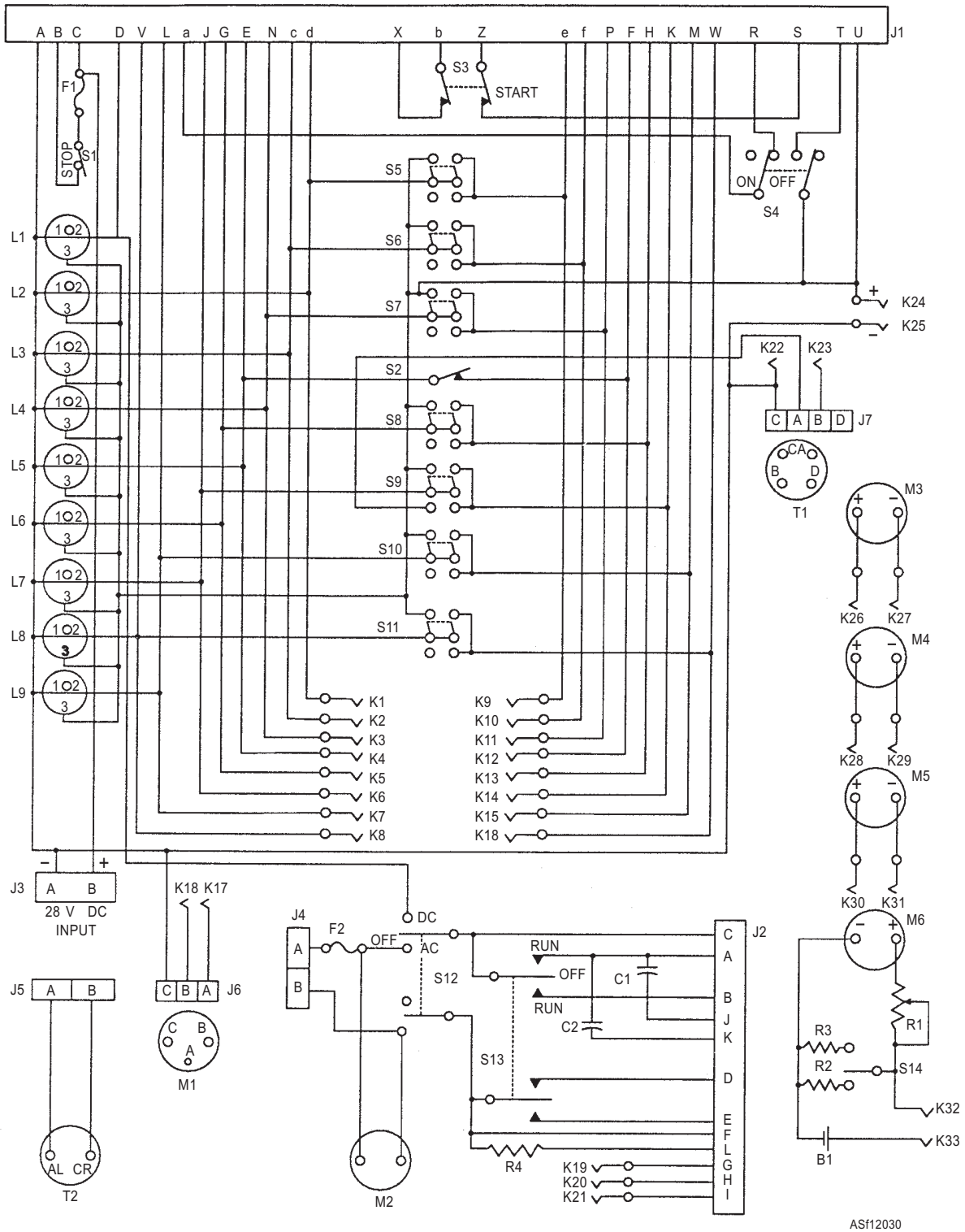

Figure 12-30.—Analyzer electrical schematic.

Refer to the schematic diagram and to figure 12-27 in discussing the analyzer's electrical system. In the diagram, letter symbols are used to indicate the different components of the system. The symbols R1 through R4 indicate resistors; C1 and C2 indicate capacitors; T1 and T2 represent indicators; F1 and F2 represent fuses; J1 through J7 represent electrical

connectors; L1 through L9 indicate lights; S1 through S14 represent switches; K1 through K33 indicate jack connections; M1 through M6 represent meters; and B1 indicates the ohmmeter battery.

Five special cable assemblies and two pairs of special leads are provided for connecting the

analyzer's electrical system measurement components and for introducing auxiliary power into the analyzer's monitoring circuits.

Speed Measurement.—Speed measurement is accomplished with a tachometer (M1). The tachometer contains two dials with ranges of 0 to 2,500 rpm and 2,500 to 5,000 rpm. The conversion chart attached to the cover door provides conversion factors for various engine gear ratios for determining actual engine speed. Two jacks (K17 and K18) provide connection from the tach generator into the tachometer circuit; ground is provided through the monitoring circuit.

Exhaust Temperature Measurement.—Exhaust temperature measurement is indicated on a temperature indicator (T2). A special two-pin electrical connector (J5) provides connection from the engine exhaust thermocouple into the temperature indicator.

Oil Temperature Measurement.—Oil temperature measurement is accomplished by a temperature indicator (T1) with a range of 0° to 150°C. Two jacks (K22 and K23) provide connection into the indicator circuit; 28-volt dc power is available to the indicator through the monitoring circuit.

Frequency Measurement.—A frequency meter (M2) with a range of 380 to 420 hertz is used for frequency measurement. This measurement is obtained and used when checking engines that drive ac generators. A two-pin electrical connector (J4) provides connection into the meter circuit.

Resistance Measurement.—Resistance measurement is obtained by an ohmmeter (M6). The ohmmeter reading can be changed ($R \times 1$ or $R \times 10$) by one or the other of the resistors (R2 and R3) connected into the meter circuit by switch S14. A 1.5-volt battery (B1) supplies the power source for the ohmmeter circuit. A potentiometer (R1) provides the zero setting of the meter, with two jacks (K32 and K33) provided for the meter connections.

Current Measurement.—Current draw can be measured by a 0 to 5 ampere dc ammeter (M4). Meter connections are provided through two jacks (K28 and K29).

Voltage Measurement.—Voltage is measured with a dc voltmeter (M3) and an ac voltmeter (M5). Jacks K26 and K27 for dc voltages and K30 and K31 for ac voltages are used to connect the voltmeters into the different circuits being measured.

Monitoring.—Monitoring is accomplished by a group of analyzer master controls for the engine and a bank of eight individual controls for individual engine components. A 28-pin electrical connector (J1) provides for the interconnection of the analyzer monitoring controls and circuits to the engine being tested. The cable that provides this interconnection is a part of the special tools for each specific engine. Reference must be made to the applicable engine's technical manual for this cable.

The analyzer master controls include an engine start switch (S3) and stop switch (S1) that provide for starting and stopping the engine at the analyzer (instead of the service installation or other control panel). A starter switch (S4) is used for motoring the engine only. A load light (L1) provides an indication of engine readiness for applying a load; switch S7 controls the engine load control valve.

The eight banks of individual monitoring circuits monitor the following engine circuits or components: auxiliary No. 1, auxiliary No. 2, load valve, starter, ignition, fuel, relay No. 1, and relay No. 2. Switches S5 through S11 are three-position switches and control seven of the circuits. With the engine powered, the DOWN (No. 3) position provides a shunt across the jacks in that particular circuit for dynamic checks. The MIDDLE (No. 2) position opens the circuit across the jacks for measurement purposes. The UP (No. 1) position applies direct current into the circuit for static test of the component or circuit.

Switch S2 is a two-position switch (spring-loaded OFF) that allows for monitoring the start circuit. In the UP position, the starter circuit is opened for measurement purposes. With the engine powered, the DOWN (OFF) position of the switch shunts across the jacks for dynamic checks.

The eight press-to-test indicator lights (L2 through L9) indicate the presence of power in a particular circuit. The light will illuminate if the circuit has power. Jacks in pairs provide access into each of the eight monitor circuits. The analyzer's monitor circuits are protected by a 5-ampere fuse (F1).

FUEL, OIL, AND PNEUMATIC SYSTEM.—The analyzer's fuel, oil, and pneumatic system provides components for measurement of engine oil pressure, fuel pressure, and control air pressure. The analyzer also provides for regulation of the engine control air.

The components of the fuel, oil, and pneumatic system include pressure gauges, elbow connections,

and a control valve. All the components are mounted on a removable panel, except the highly sensitive pressure gauge stowed in the case cover. Refer back to figures 12-16 and 12-19 for illustrations of fuel, oil, and pneumatic components. The pressure lines are locally fabricated and interconnected between the engine systems and the analyzer gauges. The pressure gauge stowed in the analyzer cover is used to check fuel cracking pressures. Refer to the applicable engine technical manual for the procedures necessary to connect the fuel, oil, and pneumatic components of the analyzer into the engine systems.

CAUTION

Apply foreign object damage (FOD) practices when working with gas turbines. All personnel are aware of the destruction caused to an aircraft jet engine when a foreign object is ingested; a gas turbine compressor can also be destroyed, or seriously damaged, if the inlet area is not kept clear of foreign objects. Never carry loose articles, such as pencils or oil-wiping cloths, in your pockets when working near operating units. Always inspect the entire area around the equipment before starting the unit to make sure no loose gear or debris can be pulled into the compressor.

SAFETY

In the operation of any gas turbine compressor unit, you must first become completely familiar with the proper operating procedures. You should not attempt to operate this equipment until you have an operational checkout by a qualified and authorized operator and you have a valid SE operator's license. The actual operation of gas turbine compressors is simple; however, they are powerful pieces of equipment and must be treated accordingly. The following safety precautions must be strictly enforced to prevent possible personnel injury or equipment destruction.

- Keep clear of the compressor inlet. Although the turbine engine of the unit is small, as compared to the engine in an aircraft, it is very dangerous and sucks in great quantities of air.
- Keep clear of the exhaust area of gas turbines. The exhaust gas from this equipment is exactly like that of the engine in an aircraft—**HOT**—and it exits from the unit at a terrific velocity. For this

reason, personnel must avoid the exhaust area and make sure that the exhaust is not directed onto anything that the heat or the velocity of these gases could damage. A tragic fire in the carrier U.S.S. *Forrestal* was started by the exhaust from one of these units. Always be certain that the exhaust is no closer than the prescribed distance from any object.

- Keep clear of the plane-of-rotation of the compressor and turbine assemblies. It is possible for a turbine blade to shear off and be thrown out of the turbine. At the speeds that the turbine turns, the blades become like rifle bullets. Usually these areas are marked clearly with red painted stripes.
- Always wear sound attenuators when working on or near operating gas turbines. The noise level from a gas turbine is very high and can cause loss of hearing. The use of the sound attenuators cannot be over stressed. Remember, a loss of hearing due to the high-frequency component of the noise generated by this equipment can and often does cause permanent damage to the auditory system.
- Operational limits for specific engines are spelled out in the applicable technical manuals. If the operational limits for a specific engine are exceeded or if seizing, unusual noise, smoke, fuel or oil leakage, or other obvious malfunctions are observed, personnel and equipment safety require that the engine be **SECURED IMMEDIATELY**. The cause of trouble must be determined and corrected before restarting.
- Prior to an engine operating test run, ensure that the engine is securely mounted in its enclosure or a test stand that provides adequate instrumentation to indicate operating conditions.
- Allow only authorized personnel in the vicinity of the test area during engine operation.

Q12-21. Which of the following terms is used to describe the unauthorized removal and replacement of parts as a method of troubleshooting?

1. Pin pointing
2. Winging it
3. Shotgunning
4. Short cutting

Q12-22. Which of the following conditions will cause a hot start or flames to be emitted from the exhaust during light-off?

- 1. Faulty atomizer*
- 2. Excessive fuel in the combustion chamber*
- 3. Faulty O-ring in the fuel control unit*
- 4. Faulty plenum drain valve*

Q12-23. Which of the following components will cause an unscheduled shutdown with no evidence of fogging during deceleration?

- 1. Defective fuel control*
- 2. Defective igniter plug*
- 3. Defective ignition holding relay*
- 4. Defective 110-percent switch*

Q12-24. Which of the following test items can be used to analyze all systems of the gas turbine compressor without removing the engine from the trailer?

- 1. The UPUA4-1 gas turbine engine analyzer*
- 2. A gas turbine engine test cell*
- 3. A dummy load bank*
- 4. A UTTS-1-7 test stand*

Q12-25. Which of the following is NOT a prerequisite for using the gas turbine engine analyzer?

- 1. Personnel should be thoroughly trained in its use*
- 2. Personnel should be familiar with the technical manual for the analyzer*
- 3. Personnel should be proficient in using a dummy load bank*
- 4. Personnel should also be familiar with the use of common electrical test equipment*

Q12-26. Which of the following protective devices protects the engine analyzer's monitor circuits?

- 1. 15-amp circuit breaker*
- 2. 10-amp circuit breaker*
- 3. 1-amp fuse*
- 4. 5-amp fuse*

Q12-27. Which of the following is NOT a correct safety precaution pertaining to operation of gas turbine compressors?

- 1. Always wear the foam-type hearing protectors when working on or near the equipment*
- 2. Always stay clear of the compressor inlet*
- 3. Always stay clear of the exhaust area*
- 4. Always stay clear of the plane of rotation*

CHAPTER 13

SHIPBOARD FLIGHT DECK EQUIPMENT

INTRODUCTION

One of the main concerns of a shop crew is to ensure that aircraft launch support equipment (SE) and aircraft crash and fire-fighting equipment are fully operational at all times. Most senior aviation support equipment technicians will agree that marginal operating performance for a piece of crash and fire-fighting SE will not only jeopardize the ship's mission as a man-of-war, but will cause havoc on the scheduled maintenance plan for the in-port periods. This becomes obvious when you consider these basic rules: An aircraft carrier cannot launch nor recover aircraft if the aircraft crash crane is inoperative; a major weapons system cannot be launched if the crash sling for that aircraft is inoperative; and all flight deck operations are handicapped if the fire-fighting equipment is not available for quick response.

Since all aircraft crash and fire-fighting equipment must be fully operational during flight operations, the scheduled maintenance and minor discrepancy repairs required to maintain this equipment must be scheduled during non-flight periods. Generally speaking, these occur during in-port periods. With this in mind, it is important that you understand the operating characteristics of support equipment. You should be

familiar with its dependability rates and know the peculiarities of its periodic maintenance procedures.

For specific operation or maintenance procedures, refer to the technical manual for the equipment you are studying.

AMPHIBIOUS ASSAULT SHIP CRASH CRANE (AACC)

LEARNING OBJECTIVES: Recognize the purpose for crash cranes. Identify the components of crash cranes. Identify procedures for troubleshooting and maintenance of crash cranes.

Crash cranes are used for lifting and removing crashed or damaged aircraft from the flight deck landing and launch areas. These cranes are self-propelled, with four individually driven wheels for high maneuverability. The cranes do not directly attach to the aircraft, but use slings. Some aircraft slings are made for particular types of aircraft. Other slings are universal; that is, not made for any particular aircraft.

The two types of aircraft crash cranes used aboard ship are the A/S32A-36A amphibious assault crash crane (AACC), shown in figure 13-1, and the

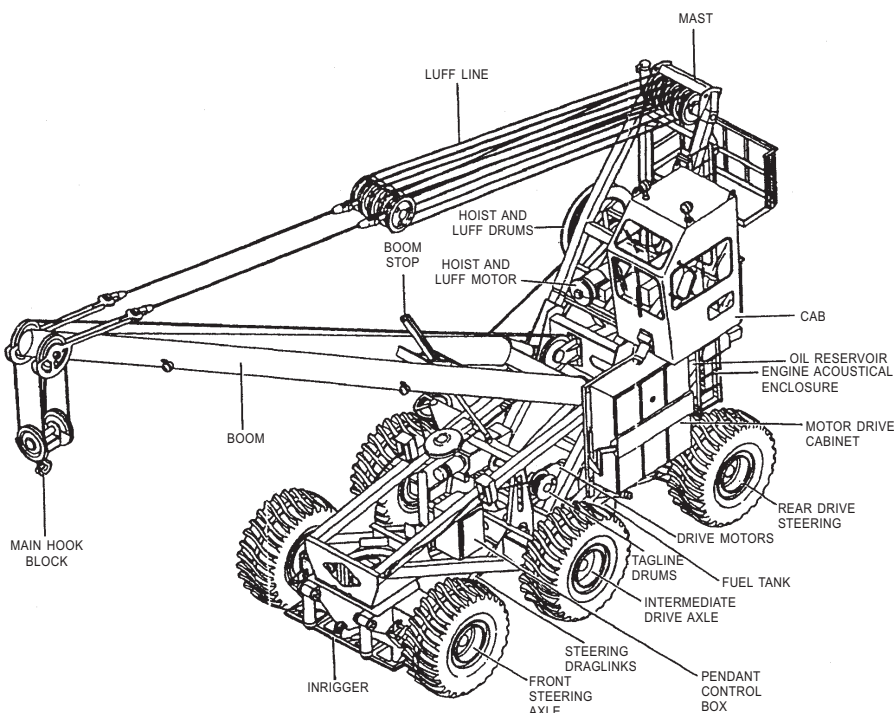

ASf13001

Figure 13-1.—A/S32A-36A amphibious assault crash crane (AACC).

A/S32A-35A aircraft carrier vessel crash crane (CVCC), which is used aboard CVNs and CVs. In this chapter, we will focus on the AACC.

The AACC is a self-propelled, diesel-electric powered vehicle constructed of a steel frame mounted on pneumatic rubber tires. At a clear outreach of 20 feet, the AACC can lift a maximum of 50,000 pounds to a height of 25 feet. At an outreach of 13.5 feet, the AACC can lift a maximum of 70,000 pounds to a height of 33 feet.

The maximum gross vehicle unloaded operating weight of the AACC is 90,500 pounds. The crane can lift crashed and damaged aircraft from various locations and attitudes and move them, on a rolling and pitching deck, to a safe parking zone. The crane can be operated aboard ship in inclement weather, and is designed for stowage on the flight deck.

The size of the crash crane may intimidate you at first. For example, the tires on the AACC crash crane are about 6 feet tall. However, on closer inspection, notice that they are mounted on a rim and are inflated to 38 psi. Conceptually, they are like any other tire, only larger. Because of their size, crash crane tires must be handled differently, but not because they are crash crane tires. Size, weight, and configuration are what make cranes seem different. But, they operate on the same principles as smaller equipment, just in different applications. It should be noted, however, that the size and weight of crash cranes make them more dangerous to operate than most other support equipment.

AACC LEADING PARTICULARS

Table 13-1 lists dimensions, weights, capacities, lift, and performance information for the AACC.

ENGINE

The engine is a two cycle, V-6 cylinder, liquid-cooled, turbo-charged Detroit diesel. It has a displacement of 92 cubic inches per cylinder, for a total displacement of 552 cubic inches. The engine idles at 900 rpm and has an operating speed of 1800 rpm in the run setting. The ac generator, which is coupled directly to the diesel engine, can provide 440 volts. The engine and generator are skid mounted to facilitate removal and replacement. The engine and generator, mounted on the skid, weigh about 7,000 pounds.

There are many accessories connected to the engine to protect it, and to provide compressed air for braking. An electronic governor controls engine speed. The AACC idles at 900 rpm and runs at 1,800 rpm to provide the proper speed for the generator.

The overspeed governor electronically disconnects the starter motor on engine start-up. It also disconnects the AC generator field current when the engine is at idle, and provides a signal source for engine overspeed. For cold weather starting, an ether start system is provided.

WARNING

When using ether, follow the procedures listed in your technical manual. Ether can be very harmful to personnel and can damage an engine if not used correctly.

When the engine and ac generator are not in use, the ship's 110-volts ac, 3-phase, 400-Hz power is plugged into the crane to supply power to the strip heaters for the engine oil and water.

AC GENERATOR

The 1,600-lb ac generator provides 440 volts of ac, 60-Hz, 3-phase output power for the crane's ac electrical circuits. A main power circuit breaker provides overload protection. Rear and mid dc drive motors provide power for crane movement.

CRANE CONTROLS

The size and weight of the power plant is intimidating, but the systems to start and control the crane are familiar to you. The crane has a 24-volt dc starting system that is supplied by four 12-volt batteries. A 75 amp, belt driven alternator recharges the batteries. Two batteries are connected in series for starting, and the two remaining batteries are also connected in series to provide backup power for starting, if necessary. The two extra batteries also supply power to the lights, heaters, defrosters, and windshield wipers.

OPERATOR'S CAB

Controls, instruments, and warning lights for operating the crane are located in the operator's cab

Table 13-1.—AACC Leading Particulars

1. Dimensions

Height (Boom Down)	25 ft
Width	15 ft
Length (Less Boom)	30 ft
Boom Length	46 ft
Ground Clearance	12 in.
Turn Radius	30 ft

2. Weight

AACC	90,500 lb
----------------	-----------

3. Equipment

QEC	7,000 lb
Engine type	Detroit Diesel
Model No	6V-92TAB
Displacement	552 cubic in.
Rated Horsepower	445 hp
Travel Motors	60 hp
Main Hoist Motor	60 hp
Tagline Motor	5 hp
Tires	29.5 × 29, 28 ply, bias, tubeless pneumatic, 38 psi
Brakes	6-wheel hydraulic drum type (self adjusting)

4. Capacities

Diesel Fuel VV-FT-800 (or JP-5)	60 gal
Engine Oil MIL-F-2104, Grade 30	18 qt
Hydraulic System (Steering - Inrigger) MIL-F-17111B	55 gal
Hydraulic System (Brakes) MIL-F-17111B	5 gal
Cooling System MIL-E-9500	6 gal
Differential (Power Train - Mid) MIL-L-2105, Grade 75W-90	6.75 pt
Differential (Power Train - Rear) MIL-L-2105, Grade 75W-90	6.75 pt
Differential (Hoisting) MIL-L-2105, Grade 75W-90	3 pt
Planetaries (Power Train - Mid) MIL-L-2105, Grade 75W-90	2 gal
Planetaries (Power Train - Rear) MIL-L-2105, Grade 75W-90	2 gal
Planetaries (Luff/Hoist) MIL-L-2105, Grade 75W-90	2 gal
Fluid Coupling (Tagline) MIL-L-2105, Grade 5	65 oz
Gear Reducer (Tagline) MOBILUBE SHC 634	3.5 gal

5. Lift Capability

Hoist	
Rated Lift at 13.5-ft Clear Outreach and 33-ft Hook Height	70,000 lb

6. Performance

Travel Speed Range (No Load)	0-5 mph
Travel Speed Range (Max Load)	0-3 mph
Main Hook Lifting Speed Range (No Load)	0-60 ±3 fpm
Main Hook Lifting Speed Range (Max Load)	0-20 ±2 fpm
Load Lowering Capability	0-10 ±1 fpm
Rolling and Pitching Ship (Rolling 5°, with or without Load)	0-3 mph

(fig. 13-2), and circuit breakers are located within easy reach of the operator. The high cab places the operator in position to view the damaged aircraft and receive signals from those on the deck.

The accelerator pedal in the crash crane works similar to the accelerator pedal in a car. The same is true of the brake pedal and steering. Both the brakes and steering are controlled by hydraulic systems.

The crane can be operated from outside the cab from a pendant control box (fig. 13-3) located on the left side of the crane, just aft of the forward wheel assembly (fig. 13-1). A fiber optic cable connects the pendant box to the crane. When using the pendant control system, the operator walks beside or behind the crane, and controls it through the use of toggle switches. Maximum speed during pendant operation is limited to about 1 mile per hour.

NOTE: To learn more about fiber optic cables, refer to Navy Electricity and Electronics Training Series (NEETS), Module 24, *Introduction to Fiber Optics*.

MOTOR DRIVE CABINET

The motor drive cabinet (MDC) is located on the left side and under the cab. The cabinet contains controls for the hoist, rear drive axle, and mid rear drive axle. The motor drive logic responds to cab and remote controls protected by various control mechanisms. The microprocessor-driven current control provides timing and firing commands to assure smooth motor operation

with overcurrent protection. The braking mechanisms are activated when speed or movement demands are removed. This allows adequate time for motor slowdown. The motor drive cabinet receives 440-volt ac, 60-Hz, 3-phase power from the ac generator. Then, ac and dc power is available from the MDC.

POWER TRAIN

The two 60 hp, dc-drive motors are identical, but coupled differently. The mid-drive motor is coupled to the differential via a universal joint coupling. The rear power-train motor is connected to the differential drive via a coupling. The differential carriers are suspended within the structural frame. Unlike the differential in a tow tractor, however, they carry no radial loads. Instead, they are used to transmit torque to the wheels. The outputs of the differential carriers are coupled to the planetary wheel drives via couplings connected to high-torque universal joint drive shafts.

WARNING

The dc motors weigh 1,675 pounds each, and each differential weighs 250 pounds. For this reason, removal and replacement must be done with great caution. Refer to the technical manual for approved procedures.

Except for accommodations for its size, an AACC wheel assembly is removed in the same way that a

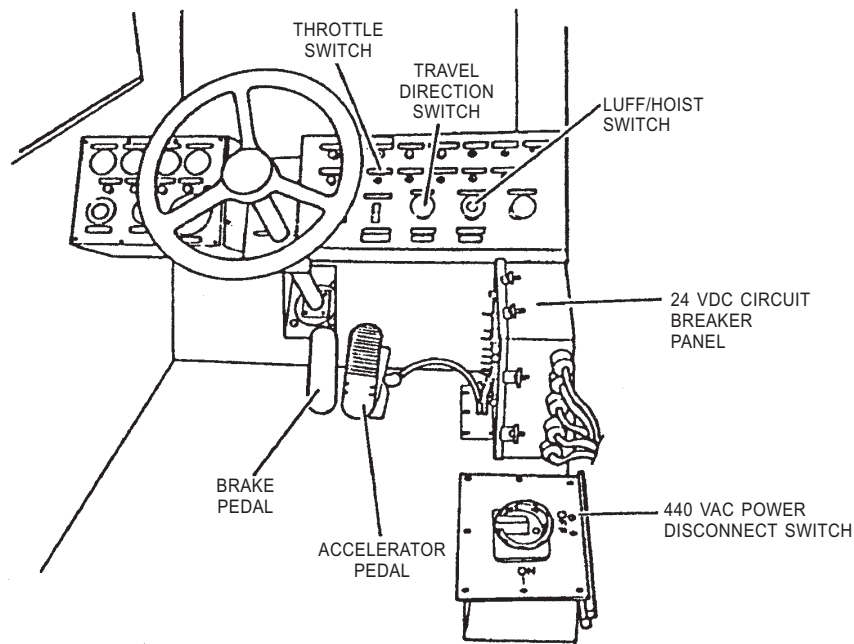

AS113002

Figure 13-2.—Operator's cab.

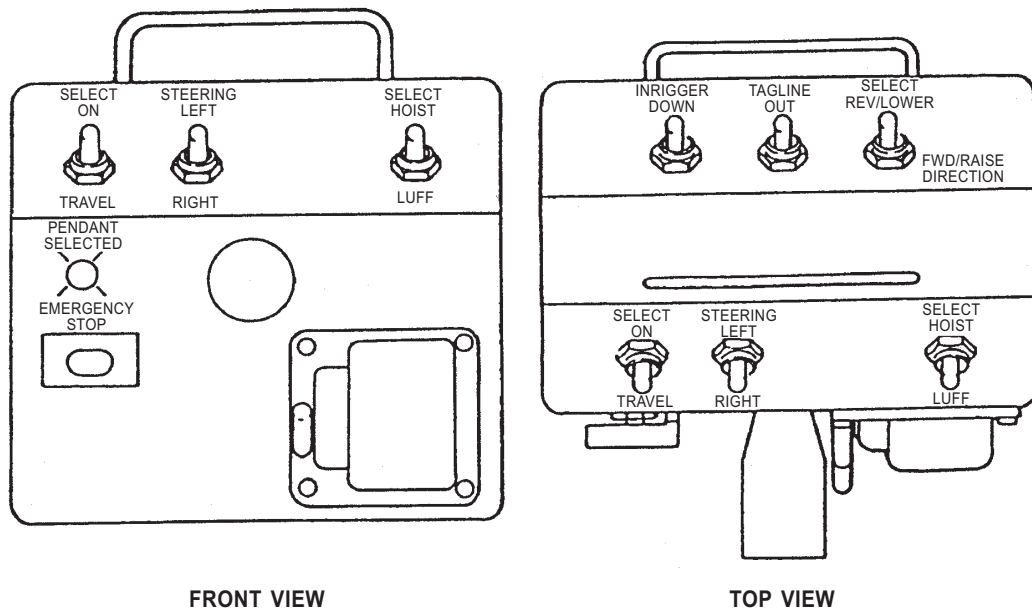

ASf13003

Figure 13-3.—Pendant control box.

wheel assembly is removed from a smaller piece of support equipment. Because the wheel assembly weighs 2,107 pounds, a forklift and sling must be used to remove it from the crane. Once removed from the crane, the wheel assembly must be secured to the forklift to keep it from breaking away.

Prior to removing a wheel assembly, be sure that you have the jack and chocks placed correctly. For detailed instructions, refer to the technical manual for the equipment and to *Support Equipment Tire and Wheel Assemblies*, NAVAIR 17-1-129.

NOTE: The AACC crash crane has no coil or leaf springs.

HOISTING SYSTEM

The crane is equipped with a non-rotating rigid steel boom that pivots on foot pins attached to the main frame. To put it simply, the boom only moves up and down. The only way to move the boom left or right is by using the steering controls to reposition the crane. The main hoist is moved by a single dc motor dedicated to that purpose.

A single dc electric drive motor provides power to raise and lower the boom through the luff/main hoist control. This 60 hp motor receives its power from the ac generator after it is converted to dc via the MDC. The motor is equipped with a dc electric brake, which is spring set when power is interrupted. This provides a

safety feature in case of malfunction during lifting operations. The brake is electrically released when power is returned.

The hook, or main hoist, is controlled by the operator and is powered by the same dc motor as the luff control. The main hook has a limiting switch that protects the hook, cable, and pulleys from damage by preventing the hook from traveling into the pulleys. The hydraulic brake system of the luff and hoisting differential is released upon selection of the operation needed at the time. This allows both systems to use one motor and one set of gears.

The other two hooks located on the left and right sides of the crane are called tag lines. These lines attach to the load and prevent it from spinning freely when lifting and moving. The tag lines are powered by a 5-hp ac electric motor. When the tag lines are not used, the hooks are stowed on handles attached to the front of the frame, one on each side.

MAINTENANCE OF CRASH CRANES

The scheduled maintenance intervals for the crash crane are critical and must be followed to the letter. The appropriate maintenance requirements cards dictate the time schedules and the proper lubricants and fluids for this unit. If scheduled maintenance procedures are not completed properly, this complex crane could fail and prevent the ship from launching aircraft or removing a crashed or disabled aircraft from the recovery area.

To remain certified, crash cranes are required to have an annual load test. Your load test date should be scheduled just prior to deployment. An aircraft crash crane that exceeds its certification period while on deployment would create an embarrassing and dangerous situation for the ship. For this reason, you must ensure all scheduled maintenance is performed on time and that all required certifications are scheduled so that they will stay current throughout the deployment.

Q13-1. What model of crash crane would be used onboard an aircraft carrier?

1. The A/S32A-35A CVCC
2. The A/S32A-36A AACCC
3. The A/S32A-37A CVCC
4. The A/S32A-38A AACCC

Q13-2. The A/S32A-36A crane's ac generator can produce how much voltage?

1. 100 volts
2. 250 volts
3. 380 volts
4. 440 volts

Q13-3. What is the lifting capability of the A/S32A-36A hoist, at 13.5 feet clear outreach and 33 feet of hook height?

1. 60,000 lb
2. 70,000 lb
3. 80,000 lb
4. 90,000 lb

Q13-4. From which of the following sources does the dc electric drive motor on the AACCC boom receive its power?

1. The motor drive cabinet (MDC)
2. The batteries
3. The operator's cab
4. The ac generator

Q13-5. When should a load test for the crash cranes be scheduled?

1. After major repairs have been performed on the crane only
2. Once every 3 years
3. Once every 2 years or after major repairs
4. Annually, after repair or replacement of a major component and prior to a deployment

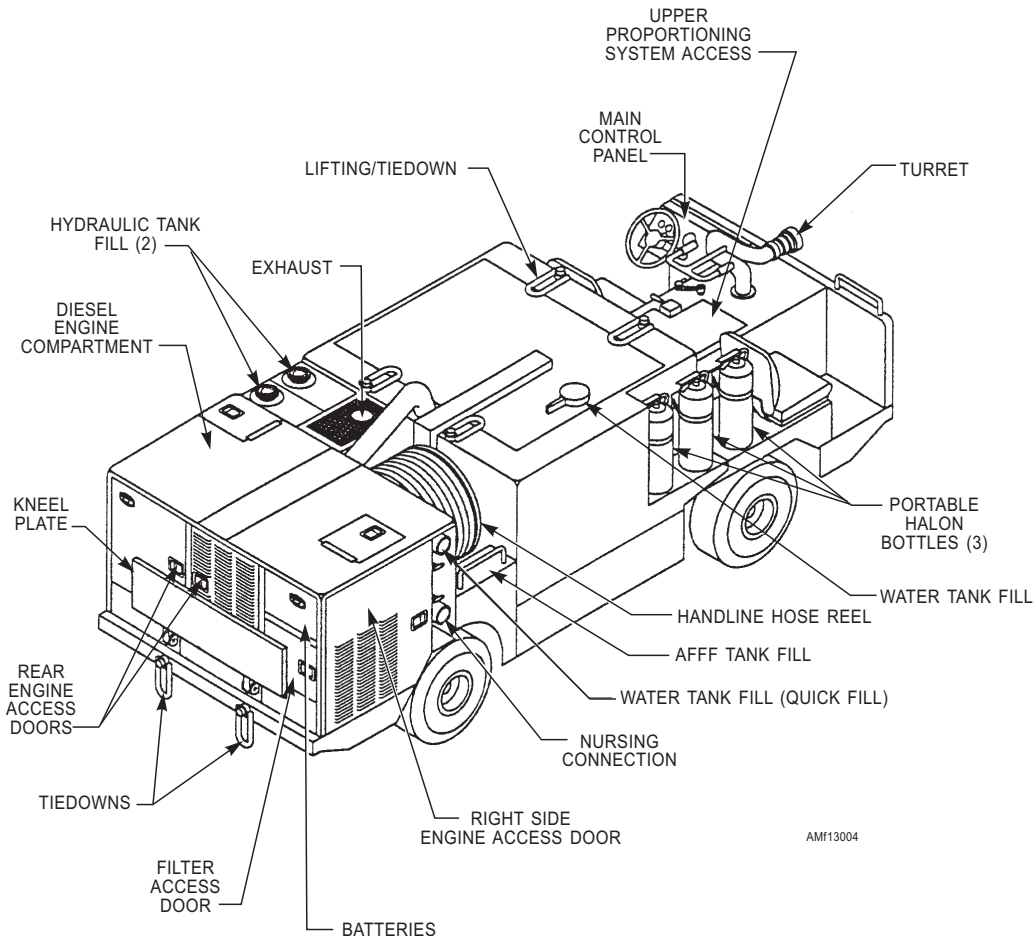

Figure 13-4.—A/S32P-25 fire-fighting truck.

A/S32P-25 FIRE-FIGHTING VEHICLE

LEARNING OBJECTIVES: Define the purpose for the A/S32P-25 mobile fire fighting units. Identify components of the fire-fighting unit. Identify procedures for troubleshooting and maintenance of the fire-fighting unit.

The A/S32P-25 fire fighting vehicle, also known as the P-25 (fig. 13-4) was designed to control or extinguish small fires on aviation ships. It is 64 inches high by 70 inches long and weighs 18,850 pounds when fully ready to fight fires. The engine is a turbocharged, after-cooled, two-cycle, six-cylinder, liquid-cooled Detroit Diesel Model 6V-53TA. It provides drive for the hydraulic and dc electrical systems. This engine has a cold weather starting system that consists of a glow plug in each cylinder combustion chamber. The P-25 uses a hydrostatic rear-wheel drive with a hydraulic motor and an axle planetary on each rear wheel. The

tire/wheel assemblies are foam filled to prevent deflation due to heat or shrapnel, and are nonreparable.

All instruments and gauges for operating and monitoring the fire-fighting truck are located on the control panel assembly in front of the driver (fig. 13-5).

HYDRAULIC SYSTEM

The A/S32P-25 employs a hydraulic system made up of three distinct subsystems—wheel drive/water drive, steering, and aqueous film-forming foam (AFFF). Knowledge of the hydraulic system principles of operation is necessary to properly operate and maintain the unit.

AFFF Hydraulic Subsystem Operation

The AFFF pump control valve receives an electrical input from the Standby/Off switch and charge

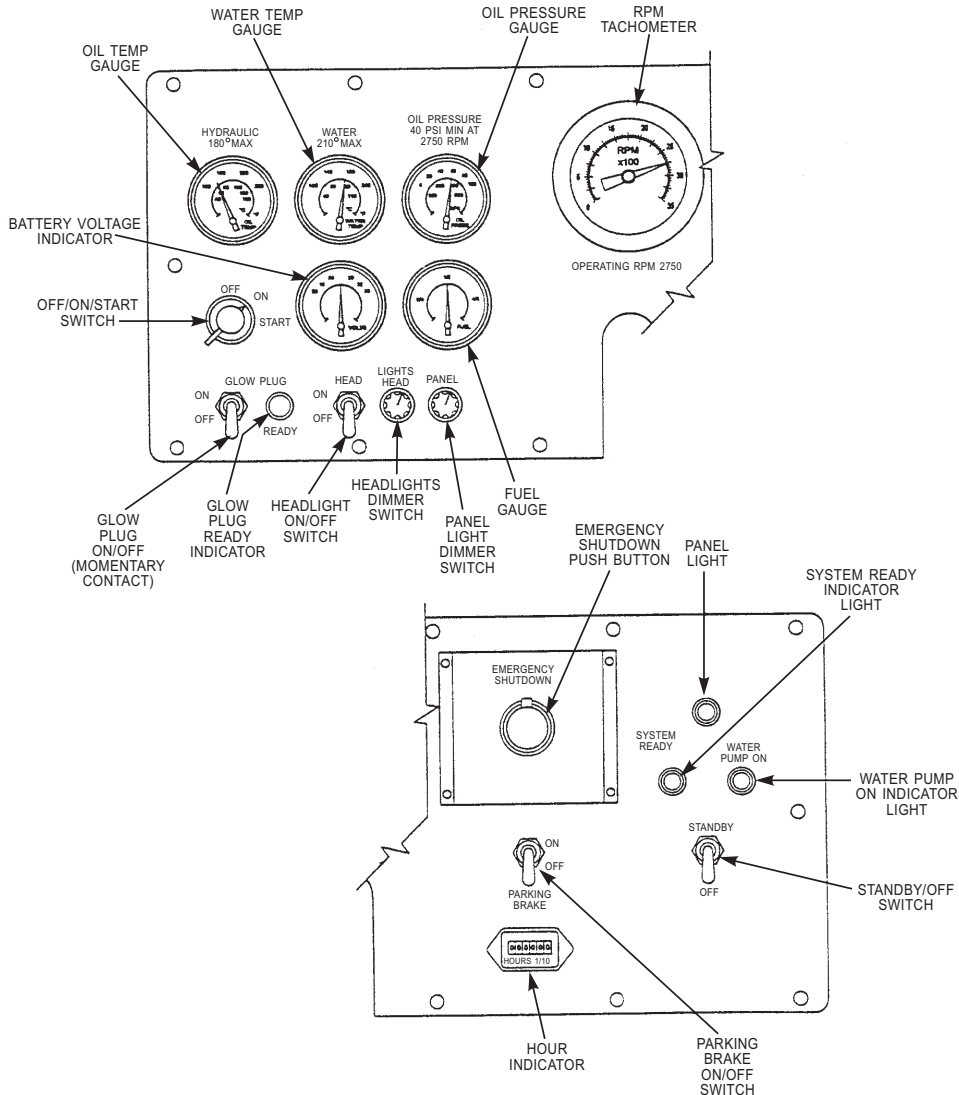

Figure 13-5.—Controls and indicators on the A/S32P-25 fire-fighting vehicle.

pressure from the 0/150/250/500/gpm joystick to allow hydraulic flow to AFFF foam pump drive motor. The pump control valve features an electrically operated PTO pump solenoid valve and a hydraulic charge pressure operated foam pump drive motor solenoid valve. When in the fire-fighting mode, hydraulic flow enters the pump control valve at port P, passes through PTO pump solenoid valve ports P and T, and exits pump control valve at port T. When the Standby/Off switch is in standby, the PTO pump solenoid valve changes state to allow hydraulic flow to the foam pump motor solenoid valve. If closed, foam pump motor solenoid valve directs flow out of port T to return line and then to the reservoir. When the joystick is moved off the “0,” the water pump is turned on, hydraulic charge pressure changes state of foam pump motor solenoid valve to direct hydraulic flow out of port B and then out control valve pump control valve at port A to drive the AFFF foam pump drive motor. When the joystick is returned to “0” (water pump off), the foam pump motor solenoid valve changes state and the foam pump drive motor is shut down.

Steering Subsystem

The steering system hydraulic tank houses 5 gallons of MIL-H-83282 (or MIL-PRF-83282) in the reservoir with an internal strainer (suction). The steering drive pump is an engine-driven pump that provides hydraulic flow and pressure for the steering system components and is mounted on the back of the engine. A pressure-relief valve maintains the system pressure at 2200 psi or below. The priority valve directs the flow from the pump to the steering valve or to the hydraulic tank. The steering control valve controls the flow of fluid to either side of the steering cylinder, depending on which way the steering wheel is turned. A steering cylinder extends or retracts to turn the front wheels of the vehicle. A check valve allows flow in one direction from the priority valve. The manual valves provide a means to isolate the reservoir from the system for system maintenance purposes. A test port is located on a tee near the priority valve to provide a port for pressure checks.

Charge Pump Circuit

The charge pump circuit performs two essential functions. It generates and regulates pressure used to control the wheel and water drive circuits and it provides a supply of makeup flow for the systems. This circuit consists of two charge pumps. These are gear type pumps that produce pressure that is combined to

create the control pressure (230-300 psi) for the hydrostatic wheel drive/water drive circuits (one in each drive pump assembly). A reservoir provides the fluid supply. The charge pump circuit controls a number of hydraulic system functions by enabling certain switches and valves to open and close, thereby controlling the flow of the hydraulic fluid. This circuit operates off from a pressure between 230 to 300 psi.

A hydraulic oil cooler or heat exchanger cools the hydraulic fluid (14.6 gpm) for hydrostatic wheel drive and water pump drive circuits. There are two charge pump check valves, one check valve per charge pump that are located in the circuit prior to the oil cooler. These prevent pressure bleed off between the charge pumps. They also help to ensure that pressure generated by one charge pump is not lost if the other pump is not operating at full capacity.

There are two filters that are drive pump mounted. They filter the charge pump fluid prior to re-entering hydrostatic wheel drive and water drive pump assemblies (one for each). Each of them has a bypass valve in case of clogging.

The pressure-relief valves regulate hydraulic pressure within the charge pump circuit. There is one in each hydrostatic wheel drive pump and water drive pump assemblies. Two pressure-relief valves are also integral with the pumps after the fluid is filtered, and all four pressure-relief valves are rated at 230-300 psi.

The charge manifold is located near the main pumps, and it provides housing for several components.

- Two check valves located in the charge pump manifold also help to prevent bleed off of charge pump pressure between the two charge pumps. These valves help ensure that if one of the pumps fail, there will be sufficient charge pressure to continue vehicle operation.

- Parking brake control solenoid valve.

- Freewheel control valve is used when the unit must be towed.

- Test point three—a site for testing the charge system pressure.

- Hydraulic fluid transducer is a sending unit that provides input to the oil temp gauge for hydraulic system fluid temperature (160°F max).

The parking brake control solenoid valve controls hydraulic pressure to modular service/parking brakes, depending on the position of the parking brake switch.

With this switch ON and the engine running, the valve remains closed and charge pump pressure is held at the solenoid valve. Moving the parking brake switch to OFF, opens the valve and circuit pressure is directed to the brake modules, overcoming the spring applied brakes.

The brake release hand pump is used to manually apply pressure to release modular brakes and free flow hydrostatic pressure in the drive circuit in case of an engine or hydraulic failure. The pump has an integral shuttle valve and a lever actuated pressure relief valve.

The freewheel control valve is manually opened and closed to apply hydraulic pressure from the brake release hand pump to shift the freewheel valve. The freewheel valve is located on the freewheel manifold and is opened by pressure from the brake release hand pump. The valve releases the hydrostatic lock on both the drive motors by allowing fluid to flow freely between the motors. The modular service/parking brakes consist of self-adjusting, pedal-operated service brakes with a master cylinder. The parking brakes require hydraulic pressure to overcome spring pressure.

The accelerator pressure control valve releases hydraulic pressure in proportion to movement of the accelerator pedal to the gear select valve. The farther the pedal is depressed the more pressure that is sent. The gear select valve directs the fluid pressure to fwd or reverse ports of the spool valve located in the main wheel drive pump assembly.

The 0/150/250/500/ gpm joystick controls the operation of water pump drive motor by directing hydraulic charge pressure to spool valve in water drive pump and AFFF foam pump drive motor solenoid. The motor speed is controlled proportionally by the joystick position (0-500 gpm).

The isolation control solenoid valve is an electrically operated hydraulic valve controlled by the STANDBY/OFF switch. It directs the charge pressure to the isolation valve hydraulic cylinder, which opens and closes the isolation valve located between the water tank and the water pump inlet. It also has a manual override knob, which opens and closes the valve in case of an electrical power failure.

The isolation valve cylinder opens and closes the isolation valve located between water tank and water pump inlet to allow water from the tank to flood the suction side of water pump in preparation for water pump operation. It also closes the isolation valve to allow the system to be drained to prevent the pipes from freezing.

Hydrostatic Wheel Drive Circuit

The hydrostatic wheel drive pump assembly is engine driven via power transfer. It provides hydraulic flow (drive) and charge pump pressure (control) to drive and control the hydrostatic wheel drive system. The wheel drive motors receive flow through the freewheel manifold from the wheel drive pump to turn the wheels and move the vehicle.

The freewheel manifold splits and directs equal fluid flow to the wheel drive motors and back to the wheel drive pump. Flow through the manifold is dependent on flow received from wheel drive pump. The flow direction is dependent on whether the F-N-R (Forward-Neutral-Reverse) lever is in forward or reverse mode. The hydrostatic wheel drive pressure test point is located in port A1 on wheel drive pump.

Water Pump Drive Circuit

The water drive pump assembly is also engine driven via power transfer and provides hydraulic flow (drive) and charge pump pressure (control) to drive and control the water pump drive system. (4350-psi max. output). The water pump drive motor receives flow from the water drive pump and the fluid flow powers the motor to mechanically drive the water pump via the water pump transmission. The water drive hydraulic pressure test point is located in port B1 of the water drive pump assembly.

Hydraulic System Safety Precautions

Ensure the hydraulic system is depressurized prior to performing work on any component or system. Hydraulic fluid MIL-H-83282 (or MIL-PRF-83282) is toxic. Ensure that you wear chemical splash goggles, rubber gloves, and an apron when feasible. Keep the fluid off the skin, eyes, and clothing. Wash affected areas immediately.

FIRE-FIGHTING SYSTEM

The P-25 fire-fighting vehicle is an important part of the ship's fire control systems. Knowledge of the fire-fighting system is necessary to properly operate and maintain the vehicle.

Component Functions

There are several components within the fire-fighting system that you must become familiar with to understand how this system operates. Once

familiar with the components, controls, and indicators, you will understand the operation of the fire fighting system more effectively.

- System ready light – Indicates water pump suction inlet is flooded and ready to pump.
- Water pump on light – Indicates water pump is operating.
- STANDBY/OFF switch – Turns the system ready light on, energizes isolation control valve, and energizes solenoid in AFFF (Aqueous film-forming foam) pump control valve.
- Turret nozzle actuation lever – Used to manually change turret spray pattern from fog to straight stream. Controlled manually and has two locking knobs to lock in vertically or horizontally.
- Turret direction control handle – Used to manually direct turret up, down, left, or right.
- Joystick 0/150/250/500 gpm (gallons per minute) – Turns on the water pump to control the water flow to the turret. The joystick can be placed in any position from 0-500 gpm.
- Inlet flushing valve – Opens AFFF piping for inducing freshwater to flush the AFFF system. It is closed during normal operation.
- Outlet flushing valve – Opens AFFF piping to expel freshwater and AFFF when flushing the AFFF system. It is closed during normal operation.
- AFFF tank return shutoff valve – Opens and closes AFFF return line to AFFF tank. It is normally open and closed when flushing.
- AFFF suction shutoff valve – Opens and closes AFFF return suction line to AFFF pump. It is normally open and closed during flushing.
- Water and AFFF line drain valves – One for each, drains the perspective line and is normally closed.
- Handline AFFF shutoff valve – Controls the flow to the AFFF ratio controller and shuts off AFFF flow from the tank to allow water only spray from the handline nozzle.
- Handline shutoff valve – Controls flow to the handline and is normally open. Should be used only when performing maintenance or if the handline ruptures while in use.

- Turret AFFF shutoff valve – Allows AFFF flow from the tank to the turret ratio controller and shuts off AFFF flow from the tank to allow water only spray from the turret.
- Handline hose reel tension adjustment knob – Locks hose reel when not in use.
- Nursing line control valves – Two 2 1/2-inch National Fire Hose threaded fittings. Pull to open valve to allow ships supplied fire-fighting agent to flow to the inlet side of the water pump. With the pump operating, the nursed agent can be pumped to both the handline and the turret.

CAUTION

The STANDBY/OFF switch must be in the off position when nursing or damage to the AFFF pump could result (AFFF tank and pump could run dry).

- Water tank quick fill valve – Pull to open to fill the vehicle water tank. Water tank capacity is 750 gallons. One 2 1/2-inch connection for servicing the vehicle's water tank.
- Water tank drain valve – Used to drain the water tank. The valve is threaded to accept a hose coupling.
- Isolation valve cylinder – Hydraulically operated cylinder extends to open isolation valve and it is activated when STANDBY/OFF switch is positioned in standby mode.
- Isolation valve – When opened by the isolation valve cylinder, the valve allows water from the tank to flood the water pump via water tank check valve in preparation for water pump operation.
- Water pump – Centrifugal-type pump provides pressure head for fire fighting system.
- Ratio controllers – Mixes the water and AFFF as provided by the back pressure regulating valve.
- Back pressure regulating valve – Controls the flow of AFFF to the ratio controllers by balancing the pressures on the water side and on the AFFF side of the system. The valve opens or closes in response to the pressure differences allowing more AFFF into the system or back to the tank.

- Y-suction strainer – Captures impurities in the AFFF concentrate before it is pumped into the system.
- AFFF tank – Stores 60 gallons of AFFF concentrate.
- Pressure-relief valves – PRV12 is set at 275 psi and it protects the AFFF concentrate side of the back pressure regulating valve and relieves the AFFF back to the tank. PRV11 is set at 225-250 psi and it relieves head pressure at the turret flow-control valve by dumping water/AFFF onto the deck.
- Check valves – Protects the AFFF concentrate side from contamination by allowing agent to flow in one direction only. They are located in the turret piping and in the handline.

Fire-Fighting System Operation

The fire-fighting system provides the dual fire-fighting capability of an onboard AFFF system augmented by three 20-pound Halon 1211 portable bottles (fig. 13-6). AFFF can be dispersed from both the turret nozzle and a 100-foot long handline with nozzle. They can be operated at the same time or independently. Maximum flow rate from the turret nozzle is 500 gpm while the flow rate for the handline is 95 gpm.

Water is pumped from the main water tank by the centrifugal water pump. A butterfly isolation valve controls the flow of the water from the tank to the pump. This valve is opened and closed by a hydraulic cylinder, which is activated by the standby/off switch on the main control panel. When open, the isolation

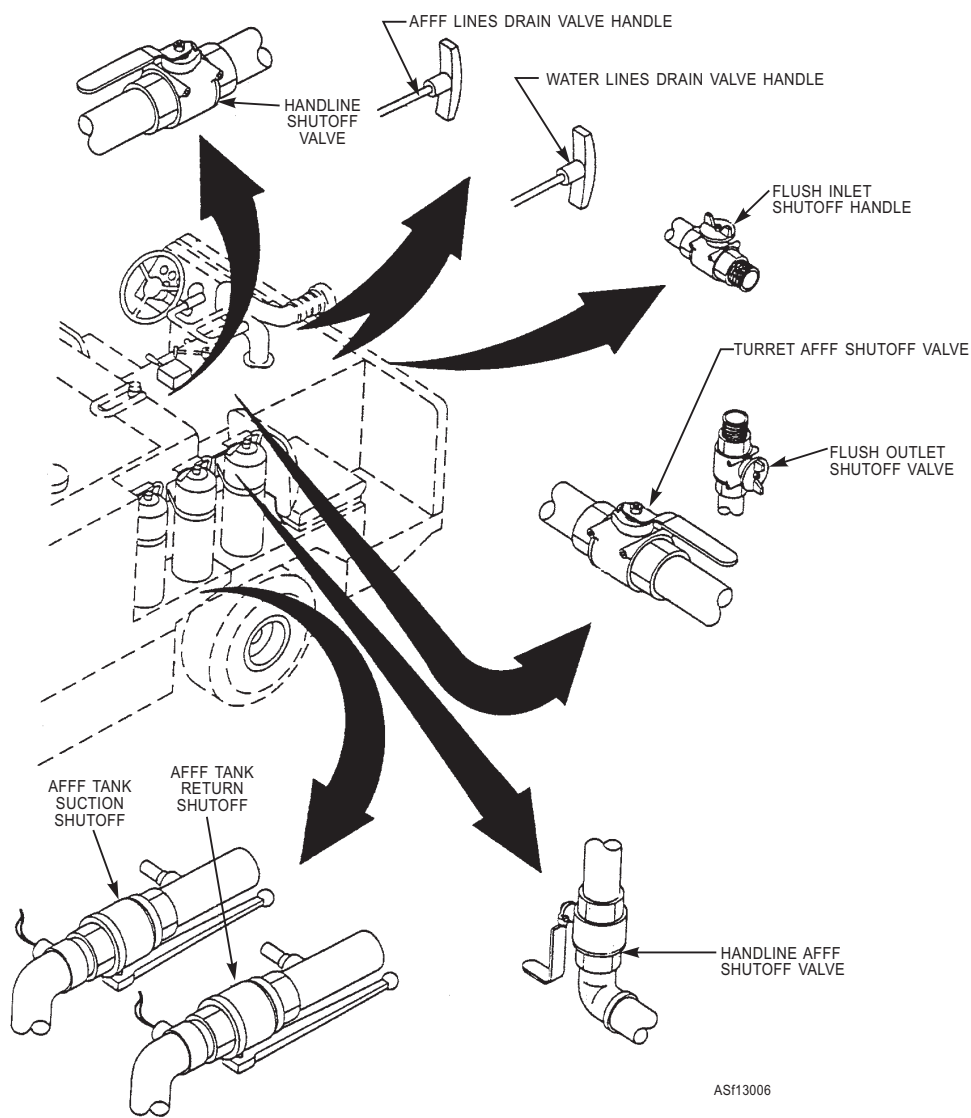

Figure 13-6.—Controls and indicators.

valve floods the inlet or suction side of the main water pump. Water is prevented from flowing back into the tank by water tank check valve. The water pump has a hydraulic motor which is driven when the 0/150/250/500 gpm joystick is moved off the "0" position with the engine running.

The water pump output is coupled to a manifold to which the turret and handline are connected. However, the water must be mixed in the correct proportion with the AFFF to obtain an effective fire-fighting agent. The AFFF concentrate is pumped from the AFFF tank by a gear-type foam pump. The AFFF pump is hydraulically driven and operates at a constant speed as it draws AFFF from the AFFF tank. The AFFF concentrate passes through a Y-suction strainer designed to capture contaminants in the AFFF before reaching the AFFF foam pump. A 1-1/2 inch pressure-relief valve controls pressure in the AFFF system by dumping excess pressure back to the AFFF tank. Water and AFFF are combined in the ratio controller (TRC & HRC). The TRC is a 3-inch ratio controller for the turret and the HRC is a 2-inch ratio controller for the handline. Both are sized by the manufacturer to ensure that water and AFFF on the input side are mixed in the proper ratio and discharged on the output side. The amount of AFFF agent available at each ratio controller is regulated by the back pressure regulating valve. This is accomplished by controlling the flow of AFFF from the AFFF foam pump back to the AFFF tank. The valve is setup to maintain equal pressure on the water and AFFF side of the system. A pressure sensing line taps into the water side just downstream of the water pump while another taps into the AFFF side downstream from the AFFF foam pump. The pressure-sensing lines act on opposing sides of a diaphragm located in the top of back pressure regulating valve. When the two sensing pressures are equal, the flow of AFFF concentrate back to the tank is maintained at a preset rate in proportion to the pressure sensed. When the sensing pressures are not equal, the diaphragm moves up or down to either increase or decrease the flow of AFFF concentrate back to the AFFF tank.

The AFFF proportioning system has two pressure relief valves. The 1-1/2 inch pressure relief valve opens when the pressure in the AFFF side of the proportioning system exceeds its preset. The valve relieves pressure by dumping AFFF concentrate back to AFFF tank. A 3 by 2 1/2 inch valve pressure-relief valve relieves any built up pressure at the turret flow control valve by opening and dumping water/AFFF to the deck.

Two check valves in the AFFF piping prevent the back flow of water/AFFF into the AFFF side of the AFFF proportioning system. There are also two shutoff valves, which isolate the AFFF and water sides of the proportioning systems. When closed, these ball valves allow the operator to shoot water only from the turret and/or handline by shutting off the AFFF flow from the AFFF side of the proportioning system. To shoot water only, the operator must also place the STANDBY/OFF switch to the OFF position. The operator then must manually actuate the isolation control valve by lifting and turning its knob clockwise. This opens the water pump isolation valve to flood the water pump without energizing the electrically actuated PTO pump solenoid valve in the AFFF pump control valve.

There are two flushing valves located on the AFFF side of the proportioning system. One is a flushing inlet valve and one is a flushing outlet valve. They provide the means for connecting a freshwater supply to the flush inlet valve and a drain line at the flush outlet valve. Then, with the AFFF tank suction shutoff valve and AFFF tank return valve closed, all AFFF proportioning system piping including the handline can be flushed with freshwater by operating the turret and handline in a normal manner. However, prior to flushing the system, the proportioning system should be completely drained. All AFFF concentrate drained from the AFFF side of the system should be returned to the AFFF tank. AFFF/water mix should never be added to the AFFF tank.

Nursing can be accomplished by via line connections. There are two 2 1/2-inch National Fire Hose threaded fittings and valves that permit the unit's fire-fighting system to nurse from the ships fire-fighting stations. By opening the nursing line control valves, the nursed agent is piped into the unit's water pump suction inlet. When running, it is pumped to the turret and/or the handline. The STANDBY/OFF switch must be in the OFF position to prevent damaging the AFFF foam pump.

The water tank quick-fill connection consists of one 2 1/2-inch connection for servicing the vehicle's water tank. It has a quick-fill control valve/lever that opens the water tank fill piping to allow for tank servicing. You must pull to open it, and it is closed under normal conditions.

Fire-Fighting System Safety Precautions

Before opening the turret flow control valve and actuating the 0/150/250/500 gpm joystick, be sure

turret is aimed away from personnel and equipment. Failure to do so can cause injury to personnel or damage to equipment.

When using the handline, be aware that the pressure could cause personnel to lose control and drop the nozzle. The handline would then represent a hazard in the area as it would spray and move uncontrollably.

When inhaled in a concentrated form directly from the bottle, Halon can be fatal. Use care to avoid discharging the Halon fire extinguishers directly at personnel.

The water pump, control valves, tanks, and piping are equipped with heaters for cold weather operation. They are located in the water tank and powered by a 440 Vac external power source. It is recommended however, that the AFFF proportioning system piping be drained if the vehicle is going to a "standby" status and cold weather conditions could freeze the water/AFFF. Before connecting heating system supply voltage cable, ensure that the heating elements circuit breakers are in the OFF position.

MAINTENANCE OF THE FIRE-FIGHTING VEHICLE

Scheduled maintenance is performed at the intermediate maintenance level on 28-, 91-, 182-, and 364-day intervals. These maintenance procedures can normally be performed while in port or underway by using a ± 3 -day scheduling tool. If you keep in mind the advantages of rotating flight deck equipment and the anticipated flight schedules, you can complete most procedures safely and securely in the work space rather than as a rush job on deck.

Unscheduled maintenance is a direct reflection of how well the flight deck personnel perform the preoperational inspections and maintain the integrity of the equipment. This is an area where the support equipment troubleshooters will have a direct influence on the well being of the P-25. Many minor repairs can be completed during the preoperational inspection, but the vehicle will have to be relocated in the shop if any major repair is required.

The A/S32P-25 fire-fighting vehicle's maintenance instruction manual is quite thorough in its repair procedures, and the fire-fighting vehicle's periodic maintenance requirements manual covers all scheduled maintenance checks.

One important consideration when determining the feasibility of scheduled and unscheduled maintenance, while in an operational status, is that the fire-fighting vehicle's water tank must be drained completely before the unit can be raised up off the deck (jacked up to relieve the weight from the suspension components). When the entire vehicle is on jack stands, remove the front jack stands first, and then the rear jack stands.

Q13-6. Which of the following is the correct model diesel engine for the A/S32P-25 fire-fighting vehicle?

1. 3V-53TA
2. 6V-53TA
3. 8V-54TA
4. 12V-54TA

Q13-7. What is the capacity of the steering system hydraulic tank on the vehicle?

1. 5 gallons
2. 8 gallons
3. 10 gallons
4. 15 gallons

Q13-8. A pressure-relief valve maintains the steering system hydraulic system pressure at or below what maximum pressure?

1. 750 psi
2. 900 psi
3. 1500 psi
4. 2200 psi

Q13-9. What is the maximum flow rate of the turret nozzle on the A/S32P-25?

1. 100 gpm
2. 250 gpm
3. 400 gpm
4. 500 gpm

Q13-10. How many Halon bottles does the A/S32P-25 fire-fighting system have available for use?

1. 1
2. 2
3. 3
4. 4

Q13-11. The A/S32P-25 has how many pressure-relief valves for the AFFF proportioning system?

1. 1
2. 2
3. 3
4. 4

Q13-12. What size is the water tank quick-fill connection on the A/S32P-25?

1. 1 inch
2. 1 1/2 inch
3. 2 inch
4. 2 1/2 inch

AIRCRAFT LIFTING SLINGS

LEARNING OBJECTIVES: Identify the purpose for aircraft lifting slings. Identify the components of aircraft lifting slings. Identify procedures for troubleshooting and maintenance of aircraft lifting slings.

Aircraft lifting slings are specialized items of support equipment whose function is to facilitate the hoisting of aircraft and aircraft components. Slings are used to hoist aircraft from the pier to carrier decks, clear crash-damaged aircraft, and remove and install wings and other major components during maintenance operations.

Aircraft lifting slings are constructed in accordance with Military Specification MIL-S-5944 and can be classified under four types of construction (or com-

binations of types). These types are wire rope, fabric or webbing, structural steel or aluminum, and chain. A typical aircraft crash sling is shown in figure 13-7.

STORAGE OF LIFTING SLINGS

Whenever possible, aircraft slings should be stored indoors in a clean, dry, well-ventilated area so as to be protected from moisture, salt atmosphere, and acids. Where practical, slings should be hung or secured in a storage rig to prevent damage from shifting and banging while underway. (Keep in mind that these slings must be available for immediate use on deck should an emergency arise.) An ideal storage procedure and location must also allow for periodic inspections and availability to reapply proper protective coatings.

INSPECTION OF LIFTING SLINGS

The inspection of lifting slings falls into two general categories—preinstallation inspections and qualification inspections. These inspections are discussed in great depth in *Inspection and Proofload Testing of Lifting Slings and Restraining Devices for Aircraft and Related Components*, NAVAIR 17-1-114.

Preinstallation Inspections

Prior to each use, or at least once a month, a complete visual inspection is performed and documented as follows:

- Wire rope cables are visually inspected for knots, fraying, stretching, abrasions, broken wires, severe corrosion, or other signs of failure. Of particular importance is the detection of a cable in which a kink has been pulled through in order to straighten the cable (commonly called a bird cage) (fig. 13-8). Any birdcage on a lifting cable is cause for rejection no matter where it is located.

- The maximum number of broken wires allowed in a cable is three per inch, and the broken wires must be distributed randomly. No two broken wires may be next to each other. No strand may have more than one broken wire per pitch length, and no broken wires are permitted within five times the cable diameter of an end fitting.

- Fabric straps should be visually inspected for cuts, holes, severe abrasions, mildew, dry rot, broken stitches, and frays. They should also be inspected for deterioration due to contact with foreign materials, such as oils, greases, fuels, and caustic cleaners.

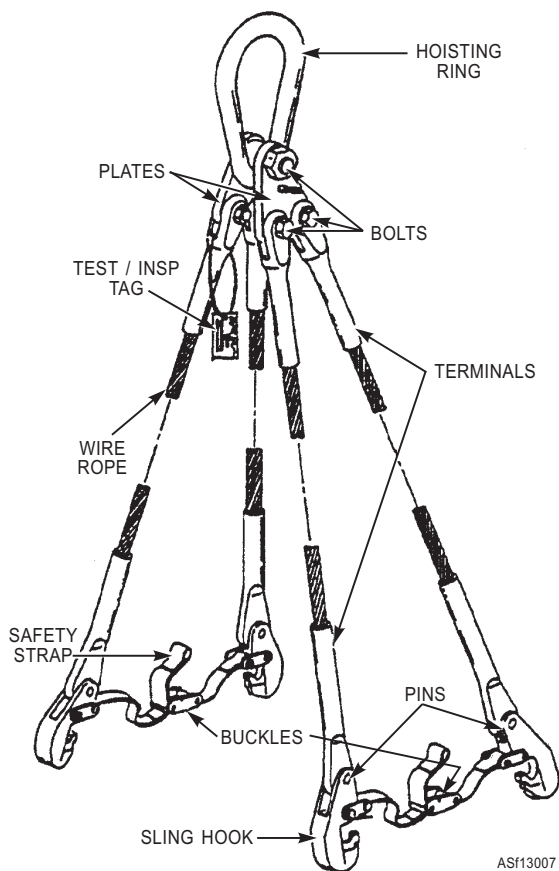

Figure 13-7.—A typical aircraft hoisting sling.

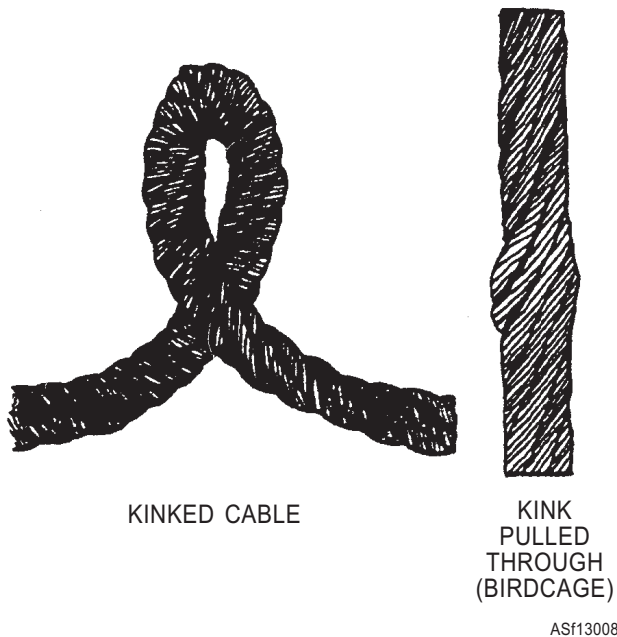

Figure 13-8.—Cable damage resulting from a pulled-through cable.

- Chain components must be inspected for stretched links, wear, gouges, open welds, fractured kinks, knots, and corrosion. The chain attachment fittings and adjusters must also be inspected for security and damage.
- The fittings and structural members should be checked by inspecting all of the terminals, shackles, lugs, and structural members for misalignment, wear, corrosion and pitting, and deformation. Ensure the latest test/inspection certification tag (fig. 13-9) is securely attached and legible.
- The inspection must be documented in accordance with the NAMP and logged in the sling's SE Custody and Maintenance History Record (OPNAV 4790/51).

Qualification Inspection

All aircraft lifting slings must be disassembled, inspected both visually and by nondestructive inspection, and requalified by an AIMD annually or upon the sling's failure to pass the preinstallation inspection. The only exception is for fabric slings; they require requalification semiannually, or upon failure to pass the preinstallation inspection.

Documentation of the qualification inspection is the same as for the preinstallation inspection, except the MAF must be kept until the completion of the next qualification inspection.

TEST/INSP CERT.	
TESTED BY	████████████████████
NEXT T/I DUE	████████████████████
TESTED IAW	████████████████████
SWL	████████████████████
28638 — 4SE00726-1	

ASF13009

Figure 13-9.—Required test/inspection certification tag.

REPAIR OF AIRCRAFT LIFTING SLINGS

In a rare situation, an inspection might reveal a damaged or defective sling component. If the component in question is a replaceable item or piece of hardware, and a pretested component can be ordered, normally the reassembled sling does not require proof-testing prior to reuse on aircraft. However, if the sling requires a complete disassembly and non-pretested components are installed, the sling must be sent to a rework facility for proof-testing/recertification. Chapter 3 of NAVAIR 17-1-114 discusses the procedures for proof-testing/certifying aircraft slings, as well as inspection requirements and storage and shipping procedures.

- Q13-13. What is the maximum number of broken wires allowed on a wire rope lifting sling?*
1. One per inch
 2. Two per inch
 3. Three per inch
 4. Four per inch
- Q13-14. Where is the proof-testing/recertification of lifting slings accomplished?*
1. At the local PWC
 2. At a rework facility
 3. At the AIMD onboard the ship
 4. At a certified civilian agency

FORKLIFTS

LEARNING OBJECTIVES: Recognize the purpose for forklifts. Identify the components of forklifts. Identify procedures for troubleshooting and maintenance of forklifts.

The forklift (fig.13-10) is a power-driven piece of material handling equipment. It is an industrial lift truck, either gasoline, diesel, or electrically powered, and has three or four wheels. It contains vertical uprights and an elevator backplate equipped with a fork of sufficient length and thickness for use with various types of pallets. Forklifts are generally used to handle palletized material like bombs or food, but they may also be used to haul boxes, containers like jet engine cans equipped with skids, and other large containers and packages.

In addition to the normal controls and indicators you expect to find on a control panel, you may also find an hour meter to measure operating time (for tracking scheduled maintenance) and a load or hydraulic pressure gauge to display the amount of weight being lifted by the forklift.

CAUTION

If you have a forklift that does not measure the load, you should check to see if the weight of the load is written on the container. If the container does not list the weight of the load, you can lift the load very slowly, watching to see if the load raises the rear wheels of the forklift off the ground. If the rear wheels lift, the load is too heavy for the forklift, and you must get a larger forklift or reduce the weight of the load.

OPERATION

Forklifts are equipped with a hydraulic cylinder to raise and lower the fork and one or two cylinders to tilt the upright. The tilt cylinders provide the means whereby the fork and upright may be tilted forward for loading and unloading, and tilted aft to stabilize the load while transporting it. In addition to these cylinders, some forklifts are provided with a hydraulic cylinder, which supplies power to move the carriage laterally to facilitate manipulation of the fork in confined areas.

Frequently, loads that could be lifted and transported with forklifts are inaccessible to the fork or must be lifted with chains or wire ropes. As a result, some forklifts are provided with a detachable boom, which may be telescopic. The boom may be attached to the upright in place of the fork. A hydraulic cylinder on the boom supplies the power to extend and retract the boom to permit accessibility to the load. The chains or wire ropes required to lift the load are attached to a hook at the end of the boom. The cylinder is connected to the hydraulic system by suitable flexible hose and fittings.

CAUTION

The chain or sling used must be rated to lift the required load and be within current load test dates.

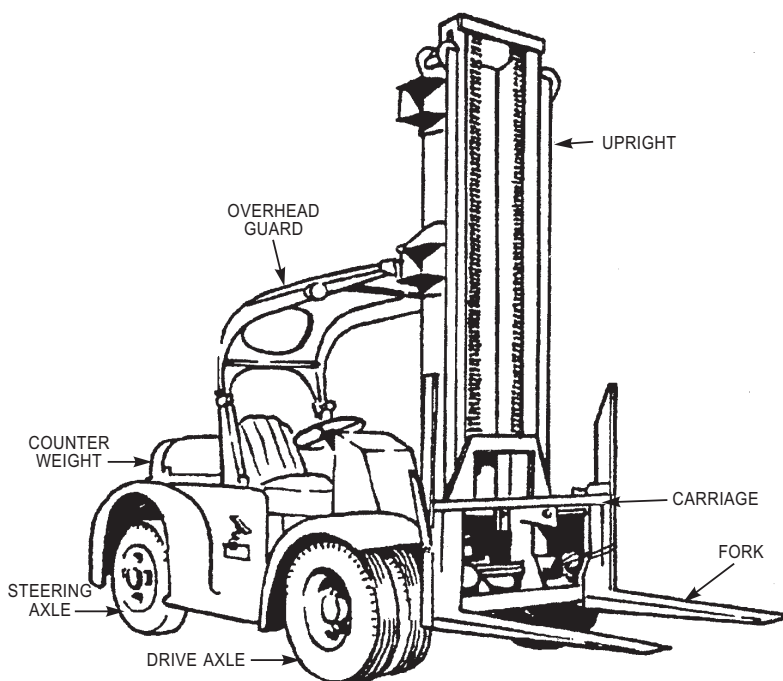

AS13010

Figure 13-10.—A typical forklift.

The most common forklift is the 6,000-pound model, often called a “6K.” For shipboard use, this forklift will have a diesel engine, an automatic transmission, rear steering, and a differential that operates on the same principle as any rear-steering vehicle (even though this is a front-wheel drive unit). Some models are driven by a bull gear system, which is much like a planetary gear system. That is, one small gear is the drive gear, and it rotates the large outer gear, which provides the torque required to transport the large payloads carried by the forklift.

The brakes are hydraulic and may or may not be powered, depending upon the model. Some models have four-wheel brakes, but many have brakes only on the two drive wheels. The parking brakes are controlled by a hand lever. One other type of brake that you will encounter on a forklift is the deadman brake (switch). There is a mechanical lever under the seat that releases the brakes when you sit down in the drivers seat. When you rise (or fall) off the seat, the spring and lever under the seat activate the brakes to stop the forklift.

WARNING

The turning radius of a forklift is very short. To achieve this short turning radius, the wheel base is short and the wheels are placed close together. This gives the forklift its maneuverability, but it also makes it unstable. Always use caution and common sense when you operate a forklift.

COUNTERWEIGHT

All forklifts have some kind of counterweight that allows the forklift to raise and travel with its payload. Some counterweights are built in as part of the frame, but most 6K forklifts have removable counterweights to permit access to components located behind the counterweights. Counterweights are very heavy, ranging from about 4,000 pounds and up. Prior to removing a counterweight, be sure to check your technical manual to see if blocks are required to prevent the forklift from tilting forward when the counterweight is removed.

HYDRAULICS

The hydraulic cylinders for the tilt and carriage assemblies on forklifts are the double-acting type. In this type, fluid must be applied to either side of the piston to provide movement in the corresponding direction. The lift cylinder, however, is single-acting, which operates similar to the cylinder assemblies of hydraulic jacks and work stands. Fluid under pressure is required to raise the piston in the cylinder. When this pressure is released through a control valve, the weight of the fork, loaded or not, will lower the piston in the cylinder.

Figure 13-11 shows a schematic for a typical forklift hydraulic system. (This schematic is included to support the explanation and does not depict any particular model. However, many of the features included in this system are found in all forklift hydraulic systems.)

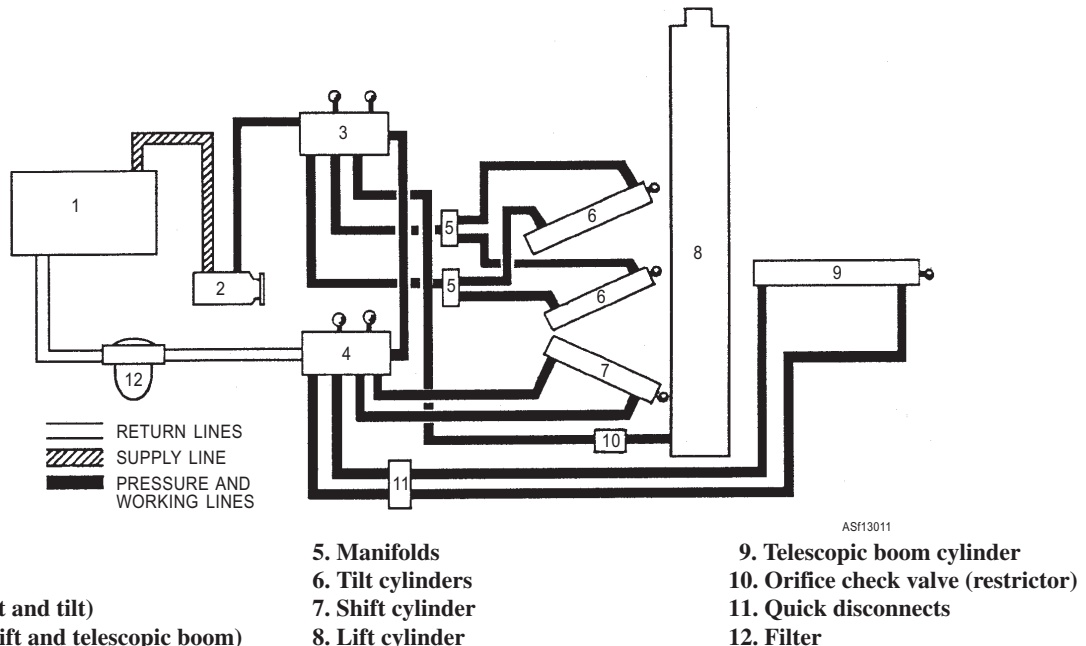

Figure 13-11.—Schematic of a typical forklift hydraulic system.

You may recall that this type of system is called an open-center system. In an open-center system, when the actuating mechanisms are idle, there is fluid flow but no pressure. The pump circulates the fluid from the reservoir, through the control valves, and back to the reservoir. The control valves in an open-center system are always connected in series, an arrangement whereby the pressure line goes through each control valve.

Fluid is always allowed free passage through the control valves and back to the reservoir until one of the control valves is positioned to operate a mechanism. Fluid is then directed from the pump through one of the working lines to the actuator. Pressure builds up in the system and provides the necessary force to move the actuator. The fluid from the other end of the actuator returns to the control valve through the opposite working line and flows back to the reservoir.

The pump (fig. 13-11) is a constant-displacement pump. On engine-driven forklifts, the pump is usually mounted on the transmission assembly and receives its power from the engine through the transmission. On electrically driven forklifts, an electric motor drives the pump. Gear pumps are normally used in these systems; however, vane pumps are used on some models. With the engine running, the pump provides a flow of fluid to the control valves.

The control valves are actually four individual control valves. The lift control valve and the tilt control valve are constructed as one assembly, and the shift control valve and the telescopic boom control valve are also constructed as one assembly. Each valve operates independently of the others, and each control valve contains a relief valve. The relief valve protects the pump from any overload of pressure. For example, if the pressure increases due to an overload, or due to an actuator extending or retracting to the end of its stroke, the relief valve opens and fluid is allowed to bypass and return to the reservoir.

To raise the fork, the lever of the lift control valve is moved aft. This directs fluid from the pump to the bottom of the lift cylinder. The orifice check valve allows free flow during the raising operation. However, during the lowering operation, the orifice check valve restricts the flow, thus preventing the load on the fork from forcing the piston of the lift cylinder to lower too fast. Flow regulators are used in some systems for this purpose. The fork is lowered by positioning the control

valve in the forward position, allowing the fluid to flow in the opposite direction back to the reservoir.

To tilt the upright, the tilt control valve lever is pulled back toward the operator. This directs the flow of fluid from the pump to one of the manifolds, where it is split into two lines and flows to the corresponding ends of the two tilt cylinders. The fluid from the opposite ends of the actuating cylinders flows through the other manifold, through the control valve, and back to the reservoir.

The shift and telescopic boom systems operate much like the tilt system. The quick-disconnect fittings are provided for convenient attachment and detachment of the telescopic boom.

There is a filter located in the return line. The filter is a full-flow type; that is, all fluid flows through the filter element. If the filter element becomes clogged and causes pressure to build up in the return line, a relief valve in the top of the filter assembly opens and allows the fluid to bypass the element and flow directly to the reservoir.

MAINTENANCE

The maintenance of the forklift hydraulic system includes periodic inspections, servicing, and repair. The inspection intervals and procedures are included in the operation and servicing instructions. Inspection consists mainly of checking for external leaks, damaged tubing and flexible hose, loose fittings, etc. You should pay particular attention to the type of fluid used for servicing the system. Consult the technical manual for the correct fluid specification.

Suppose one of the subsystems, like the lift system, fails to operate. Before assuming it is defective, first check the operation of one or more of the other subsystems. If more than one fails to operate, the trouble is probably in the power system. The power system includes those components necessary to supply fluid to the control valves. In this case, the power system includes the reservoir and the pump. Check the fluid level in the reservoir first, and then check the output of the pump.

If the other subsystems operate normally, the malfunction is probably due to an internal leak in the lift actuating cylinder or the lift control valve. Similar procedures may be used to determine the cause of malfunctions in the other subsystems.

In general, the procedures for troubleshooting and repairing a forklift are similar to those for repairing other pieces of support equipment. The systems are similar—they are just arranged differently. Review your technical manual and follow the guidelines contained therein.

Q13-15. What type of engine does the 6K forklift have?

1. A gasoline engine
2. An electric motor
3. A diesel engine
4. A hydraulic motor

Q13-16. What is the purpose of the deadman switch used on a forklift?

1. It will stop the engine when the operator is not sitting on the seat
2. It will apply the brakes when the operator is not sitting on the seat
3. It will lock the boom in place when the operator is not sitting on the seat
4. It will disable the steering when the operator is not sitting on the seat

Q13-17. If the lever of the lift control valve is moved aft, what happens to the forks?

1. The forks will rise
2. The forks will descend
3. The forks will be locked
4. The forks will shift to the right

FLIGHT DECK SCRUBBER

LEARNING OBJECTIVES: Recognize the purpose of flight deck scrubbers. Identify the components of flight deck scrubbers. Identify procedures for troubleshooting and maintenance of flight deck scrubbers.

At first glance, a flight deck scrubber might seem to be a luxury item; but reconsider. In cities and towns where mechanical street sweepers are used, the streets are undoubtedly cleaner than in places where they are not. Street cleaners help to keep streets free of dirt, rocks, nails, and other debris. The flight deck scrubber serves the same function on the deck of an aircraft carrier, and on a flight deck, cleaner means safer.

The flight deck scrubber (fig. 13-12) is diesel powered with a hydraulic pump that is directly coupled

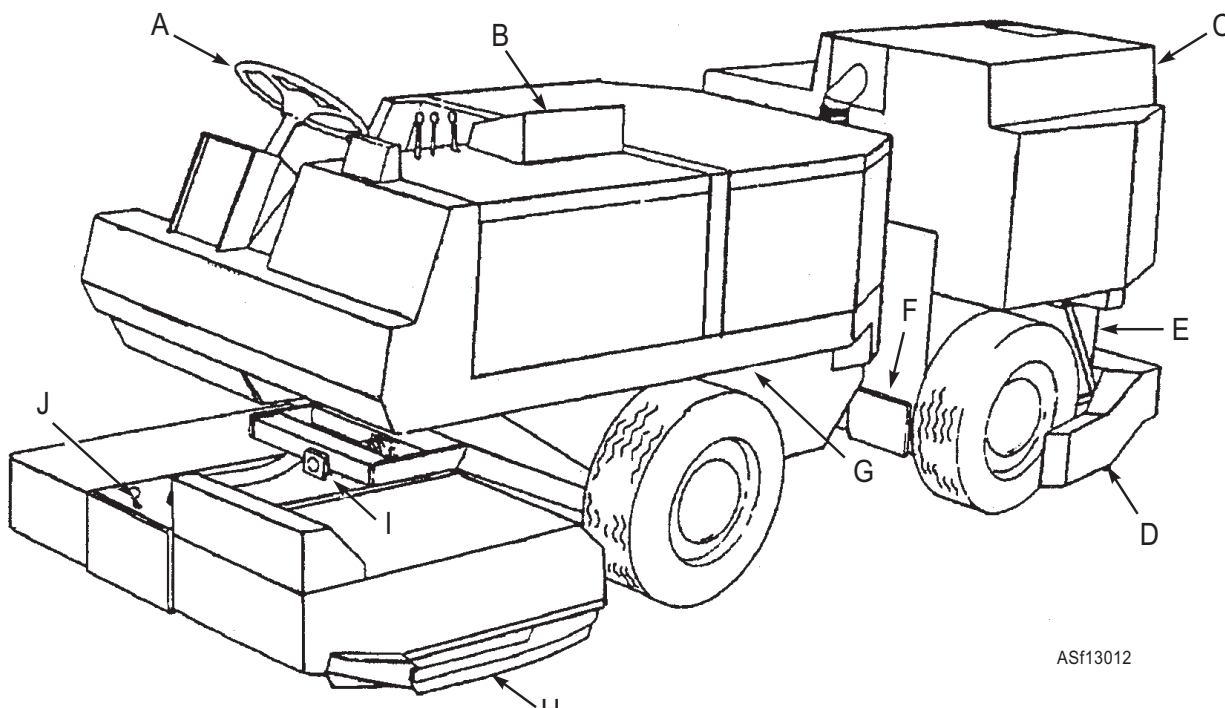

ASf13012

- A. Steering wheel
- B. Instrument panel
- C. Solution tank
- D. Rear squeegee

- E. Recovery tank
- F. Clean-out door
- G. Articulated joint
- H. Side squeegee

- I. Head pivot
- J. Debris trough release lever

Figure 13-12.—Flight deck scrubber.

to the engine. The hydraulic pump provides fluid flow to the power train. Two hydraulic drive motors on the front wheels produce a maximum forward speed of 9 mph and a maximum speed in reverse of 5 mph.

OPERATION

Placing the throttle lever (fig. 13-13) in the “Full” position puts the engine in the governed speed mode.

Both speed and direction are controlled by the directional control pedal. With the engine at governed speed, the scrubber moves forward when the operator presses on the top of the directional control pedal. The

more the pedal is depressed, the faster the scrubber travels. When the operator removes his foot, the scrubber goes into neutral. Pressing on the bottom of the pedal puts the scrubber in reverse.

The control panel (fig. 13-13) is located to the left of the operator. Most of the controls and gauges are similar to those you have seen on other support equipment, except for the controls used to operate the cleaning components. The squeegee control lets the operator lower the squeegees in order to trap water and debris from the deck, which is then vacuumed into the recovery tank. The scrub brush controls allow the operator to control the rotating brushes. The scrub

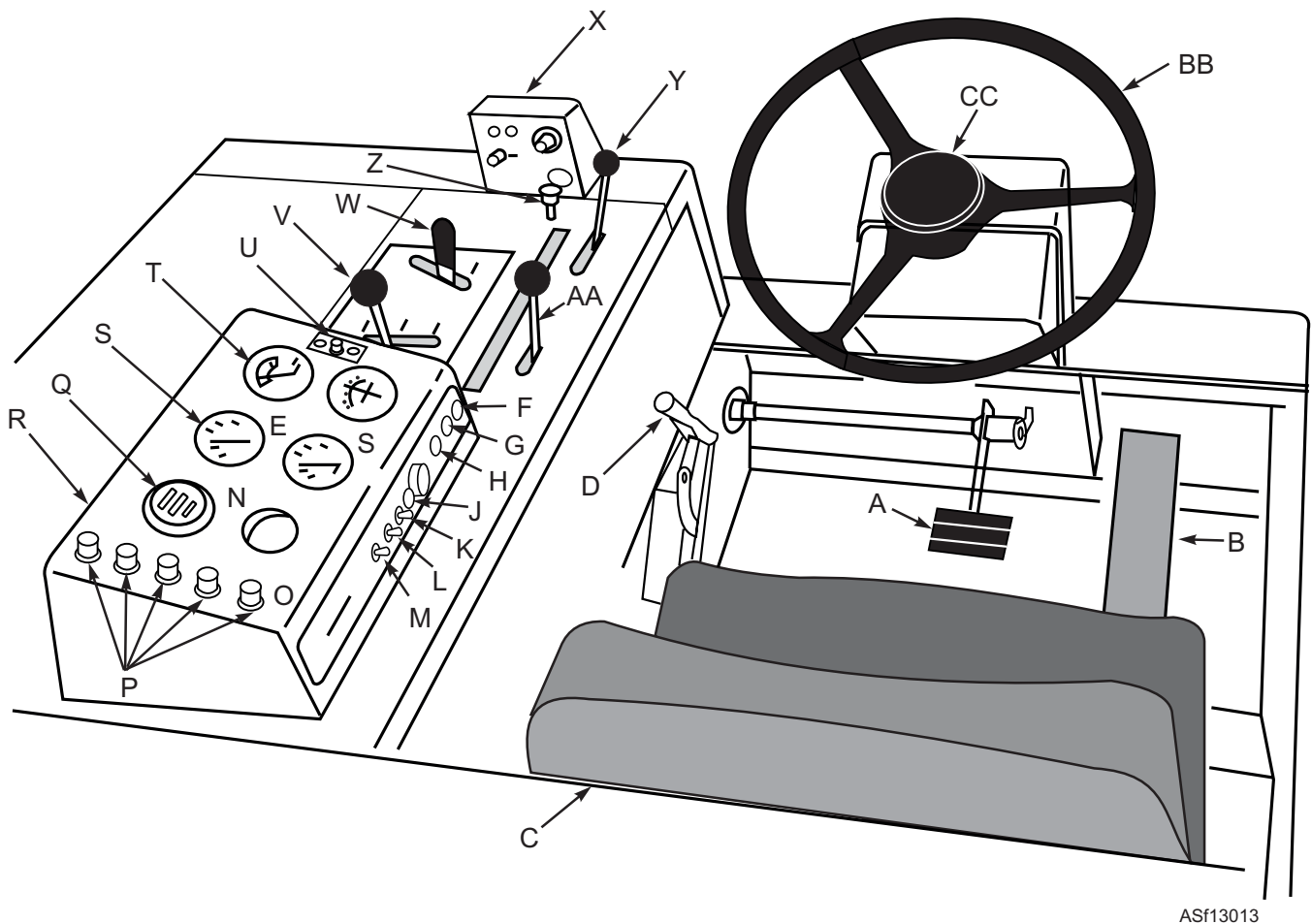

ASf13013

- | | | |
|-----------------------------------|-------------------------------------|------------------------------|
| A. Brake pedal | K. Operating lights switch | U. Squeegee switch |
| B. Directional pedal | L. Rotating light switch | V. Scrub brush lever |
| C. Operator seat | M. Hazard light switch | W. Scrub head position lever |
| D. Parking brake lever | N. Fuel level gauge | X. SRS® panel |
| E. Ammeter | O. Panel lamp | Y. Solution lever |
| F. Squeegee position lamp | P. Fuses | Z. Choke knob |
| G. Tank drain lamp | Q. Engine hour meter | AA. Throttle lever |
| H. Scrub brush pressure lamp | R. Instrument panel | BB. Steering wheel |
| I. Ignition switch | S. Oil pressure gauge | CC. Horn button |
| J. Diesel preheat indicating lamp | T. Engine coolant temperature gauge | |

Figure 13-13.—Flight deck scrubber instruments and controls.

WARNING: Crush Hazard Between Front And Rear Halves Of Machine. Engage Pivot Lock.

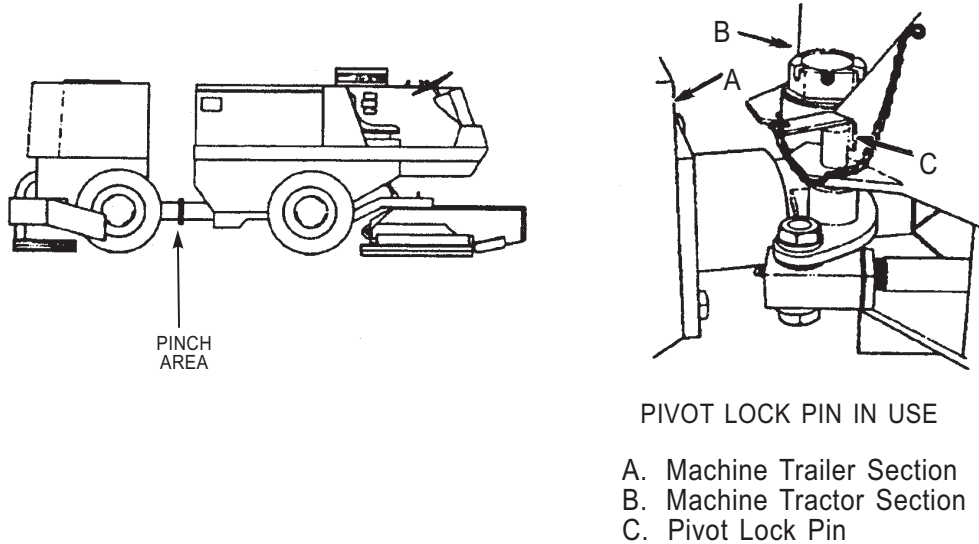

AS13014

Figure 13-14.—Pinch area and pivot lock pin.

brush lever is a three-position lever (ON, OFF, and REVERSE) that controls the spin of the brushes. The scrub head position lever is a lever that controls the position of the scrubbers (RAISE, HOLD, and LOWER). The SRS® panel is a control box (control panel) and solution lever that controls the application of the cleaning solution.

A diesel engine drives the flight deck scrubber's hydraulic system. Components of the hydraulic system include the two hydraulic motors for the scrub brushes, the cylinder for the scrub head lift, the cylinder for the rear squeegee lift, and the steering cylinder. The complete hydraulic system, including the hydraulic reservoir, requires 13.8 gallons of hydraulic fluid.

The front disc brake assembly provides the service brake and the parking brake on the same disc. The master cylinder is a nonpowered type, and the parking brake is operated by a cable from the drivers seat.

CLEANING SYSTEM

The flight deck scrubber uses two rotating scrub brushes to clean the deck. There are two types of brushes available; one is made of polypropylene, and the other is an abrasive bristle. Both types of brushes are 50 inches long and have a diameter of 11 inches (fig. 13-15).

WARNING

The area between the front and rear halves of the flight deck scrubber is known as a pinch area because the halves come together during a turn. (See fig. 13-14.) During maintenance activities, the articulated joint can be locked with a pin to keep the halves from accidentally coming together. The pivot locking pin is hung on the tractor section of the flight deck scrubber, adjacent to the pivot point. The pin should be inserted prior to working in this area. And, when work is completed, be sure to remove the pin so that full steering is available to the operator.

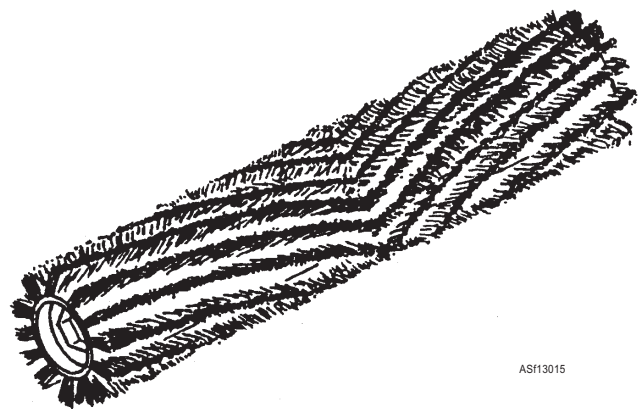

AS13015

Figure 13-15.—Scrub brush.

The solution tank (fig. 13-12) holds 140 gallons of cleaning solution that is delivered to the scrub brushes by an electrical pump. The recovery tank holds 120 gallons. Because there is a 20 gallon difference between the two tanks, you may have to empty the recovery tank before you use up the entire contents of the solution tank. The recovery tank is equipped with a ball float shutoff actuated device to prevent overflow. All large debris, such as string and wire, should be removed from the deck before you start cleaning operations.

The vacuum fan is belt-driven from the engine and provides the suction to pull water and debris from the deck at the rear squeegee. To work most efficiently, the squeegee must be properly adjusted as outlined in the technical manual.

Two hand-controlled components allow the operator to reach places that cannot be reached by the scrubber. One is a high-pressure sprayer that can spray water or cleaning solution at 4 gal/min at a pressure up to 800 psig. The second component is a vacuum wand with a 20-foot hose.

MAINTENANCE

To be effective, the flight deck scrubber must be very carefully maintained. Scheduled and unscheduled maintenance are a must. The flight deck and hanger deck are covered with a nonskid compound to provide a traction surface for the safe movement of aircraft, equipment, and personnel. The nonskid surface is very destructive to the brushes and squeegees, so, they must be carefully adjusted and replaced when worn.

Space aboard ship is at a premium, and clearances for the scrubber are close. In addition, the scrubber must clean as close as possible to bulkheads, and this means that components such as brushes and squeegees can easily get bent or knocked out of alignment. To keep the scrubber operating correctly, inspect it frequently and follow the prescribed maintenance schedules. Remember the alternative—if your scrubber is out of service, you may have to do the job with long-handled scrub brushes.

Q13-18. What is the maximum forward speed of the flight deck scrubber?

1. 5 mph
2. 9 mph
3. 11 mph
4. 14 mph

Q13-19. Where is the “pinch area” on the flight deck scrubber?

1. The area below the edge of the front scrubber deck
2. The area below the edge of the aft scrubber deck
3. The between the top of the aft scrubber deck and the frame
4. The area between the front and rear sections of the scrubber

TROUBLESHOOTING SUPPORT EQUIPMENT

LEARNING OBJECTIVE: Identify the five steps for properly troubleshooting an item of support equipment.

Troubleshooting is one of the most important, yet least understood, tasks an AS performs. Before you can troubleshoot a piece of equipment, you must have a thorough understanding of the operating procedures and characteristics of the equipment. You must know what indications are normal before you can identify the conditions that are not normal. The five-step troubleshooting technique is proven and very effective in finding the malfunction and performing necessary repairs. The five steps are operate, analyze, isolate, repair, and operate.

- **Preoperational Inspection/Operate**—The first step in troubleshooting a discrepancy is a proper preoperational inspection, using the preoperational checklist for the equipment. During the preoperational inspection, ensure a thorough visual inspection is accomplished. Look for obvious signs for the cause of the malfunction. After completion of the preoperational inspection, the next step would be to operate the equipment. You should verify what systems are operating properly as well as any systems that are malfunctioning. Attention to detail while operating the equipment is essential. Problems that seem unrelated may save hours of testing if they are identified at this point. A panel light that is operational may tell you that the fuse is good for the circuit that is malfunctioning. Systems that operate will tell you what part of the system you don't need to check. Several systems that are not operational will lead you to a common point that caused the malfunction.

- Analyze—Use the information gathered during the operate step, along with the schematics, diagrams, and other information in the maintenance manuals, to determine the possible cause of the malfunction. All possible causes of the problems should be identified during this step.

- Isolate—Check each possible cause from the analyze step until the problem is located. The checks should be performed from the most likely to the least likely cause. Moving parts are more likely to fail than stationary parts. If the problem can not be located at this point, you may need to start over with the operate step. You may have overlooked an indication that identifies the source of the problem.

- Repair—During this step, the malfunction(s) discovered in the isolate step are corrected.

- Operate—After all repairs are completed, you must operate the equipment to ensure proper operation. You must, as in the first step, verify that all systems are operational.

When you use this five-step approach, you should be able to find the malfunction on any type of equipment or system. The steps work the same for mechanical, hydraulic, or electrical systems with consistent reliability.

CAUTION

Always observe safety and proper maintenance procedures when performing troubleshooting and maintenance.

Q13-20. What are the five steps to proper troubleshooting?

- 1. Operate, analyze, isolate, repair, and operate*
- 2. Operate, repair, isolate, troubleshoot, and operate*
- 3. Troubleshoot, repair, analyze, operate, and sign off the MAF*
- 4. Troubleshoot, analyze, isolate, repair, and operate*

Q13-21. What is the first thing you should do when the squadron turns in a tow tractor and says it won't stay running?

- 1. Begin troubleshooting as soon as possible to reduce turn around time.*
- 2. Notify the work center supervisor*
- 3. Write a VIDS/MAF*
- 4. Perform an operational check*

APPENDIX I

GLOSSARY

ABDC—After bottom dead center.

ABSOLUTE—The temperature measured using absolute zero as a reference. Absolute zero is -273.16°C or -459.69°F.

ACCELERATION—Time rate of change of velocity.

ACCELERATION PUMP—A device in the carburetor that supplies an additional amount of fuel, temporarily enriching the fuel-air mixture when the throttle is suddenly opened.

ACCELERATOR—Pedal and linkage used to control engine speed.

ACCUMULATOR—A device for storing liquid under pressure. It usually consists of a chamber separated into a gas compartment and a liquid compartment by a piston or diaphragm. An accumulator also serves to smooth out pressure surges in a hydraulic system.

AC—Alternating current or current that reverses its direction at regular intervals.

ACTUATOR—A device that converts fluid power into mechanical force and motion.

ADDITIVE—A chemical compound or compounds added to a fluid to change its properties.

AFFF (AQUEOUS FILM FORMING FOAM)—(A fire fighting agent.) A liquid concentrate, which consists primarily of synthetic fluorocarbon surfactant materials.

AIR, COMPRESSED—Air at any pressure greater than atmospheric pressure.

AIR BLEED—A passage in the carburetor through which air can seep or bleed into fuel moving through a fuel passage.

AIR BRAKES—Vehicle brakes actuated by air pressure.

AIR CLEANER—A device through which air must pass before entering the cylinders of an internal-combustion engine. On gasoline engines equipped with carburetors, it is mounted on the carburetor air horn. On engines with fuel injection

(gasoline and diesel), it is mounted on or in-line with the air inlet housing. A filtering device in the air cleaner removes dust and dirt particles from the air.

AIR CONDITIONING—A system designed to provide control over air temperature, movement, and humidity.

AIR-COOLED ENGINE—An engine cooled by air circulating between the cylinders and around the cylinder heads, as opposed to the liquid-cooled engine that is cooled by a liquid passing through jackets surrounding the cylinders.

AIR FILTER—A filter through which air passes, and which removes dust and dirt particles from the air. Air filters are placed in passages through which air must pass, as in the crankcase breather, air cleaner, etc.

AIR-FUEL RATIO—The ratio between the volume of air and the volume of fuel used to establish the combustible mixture in the cylinder of an internal-combustion engine.

AIR HORN—That part of the air passage in the carburetor of a gasoline engine that is on the atmospheric side of the venturi. The choke valve is located in the air horn.

ALLOY—A mixture of two or more metals.

ALTERNATOR—An electrical system device that converts mechanical energy into electrical energy for charging the battery. Also known as an ac generator, the alternator produces alternating current (ac) which must be changed (rectified) to direct current for use in an automotive electrical system.

AMBIENT—Surrounding, such as ambient air, meaning surrounding air.

AMBIENT TEMPERATURE—The temperature of the environment surrounding an object.

AMMETER—An electric meter that measures current, in amperes, in an electric circuit.

AMPERE—Unit of measurement of electric current flow. The current that will flow through a 1-ohm of

resistance when 1 volt is impressed across the resistance.

ANTI-FRICTION BEARING—A bearing of the type that supports the imposed load on rolling surfaces (balls, rollers, needles), minimizing friction.

ANTI-KNOCK—Refers to substances that are added to automotive fuel to decrease the tendency to knock when the fuel-air mixture is compressed and ignited in the engine cylinder.

ANTIFREEZE—A chemical, usually ethylene glycol, added to the water in cooling system (usually a 50/50 mixture) in a liquid-cooled engine to prevent freezing and to raise the boiling point of the coolant.

ARMATURE—(1) In a relay, the movable portion of the relay. (2) The windings in which the output voltage is produced in a generator or in which input current creates a magnetic field that interacts with the main field in a motor.

ASBESTOS—A fibrous material that resists heat and burning.

ATDC—After top dead center.

ATMOSPHERE—The mass of air that surrounds the earth.

ATMOSPHERIC PRESSURE—The weight of the atmosphere per unit area. Atmospheric pressure at sea level is 14.7 pounds per square inch (psi).

ATOM—The smallest particle, or part, of an element, composed of electrons and protons and also of neutrons (with the exception of hydrogen).

ATOMIZATION—The spraying of a liquid through a nozzle so that the liquid is broken into tiny globules or particles.

AUTOMATIC CHOKE—A choke that operates automatically in accordance with certain engine conditions, usually temperature and intake manifold vacuum (also electrically controlled).

AUTOMATIC TRANSMISSION—A transmission that reduces or eliminates the necessity of hand shifting of gears to secure different gear ratios in the transmission.

AXIAL—In a direction parallel to the axis. Axial movement is movement parallel to the axis.

AXIS—A centerline. The line about which something rotates or about which something is evenly divided.

AXLE—A cross support on a vehicle on which a supporting wheel, or wheels, turn. There are two general types: live axles that also transmit power to the wheels, and dead axles that transmit no power.

BACK PRESSURE—The resistance of liquids and gases to flow through a system.

BACKFIRE—Pre-explosion of the fuel-air mixture so that the explosion passes back around the opened intake valve and flashes back through the intake manifold.

BACKLASH—The backward rotation of a driven gear that is permitted by clearance between meshing teeth of two gears.

BAFFLE—A plate or shield to deflect, check, or regulate the flow of a liquid or gas.

BALL BEARING—A type of bearing that contains steel balls that roll between inner and outer races.

BALLAST RESISTOR—A resistor that changes voltage in direct proportion to the heat of the resistance element. Such a resistor is used in the ignition system of gasoline engines.

BAROMETER—An instrument that measures atmospheric pressure.

BATTERY—A device consisting of two or more cells for converting chemical energy into electrical energy.

BATTERY CAPACITY—Rating of a battery's current output, usually expressed in ampere-hours or cold-cranking-amperes.

BATTERY CHARGING—The process of supplying a battery with a flow of electric current to produce chemical actions in the battery; these actions reactivate the chemicals in the battery so they can produce electrical energy again.

BATTERY, MAINTENANCE-FREE—A battery that does not require addition of water during its normal life.

BATTERY RATING—A standardized measurement of a battery's ability to deliver electrical power under certain conditions. *See also* BATTERY CAPACITY.

BBDC—Before bottom dead center.

BDC—Bottom dead center; the position of the piston when it reaches the lower limit of travel in the cylinder.

- BEAD**—The circular wire-reinforced section of a tire that joins with the wheel rim.
- BEARING**—A part in which a journal pivot, or pin, turns or revolves. A part on or in which another part slides.
- BENDIX DRIVE**—A type of drive used in a starter that provides automatic coupling with the engine flywheel for cranking and automatic uncoupling when the engine starts.
- BERNOULLI'S PRINCIPLE**—If a fluid flowing through a tube reaches a constriction, or narrowing of the tube, the velocity of the fluid flowing through the constriction increases and the pressure decreases.
- BEVEL GEAR**—One of a pair of meshing gears whose working surfaces are inclined to the centerline of the driving and driven shafts.
- BEZEL**—A device used to attach a glass face to an instrument.
- BLACKOUT LIGHTS**—A lamp installed on a vehicle for use during blackouts, which can be seen from the air only at very close range.
- BLEEDER, AIR**—A bleeder for the removal of air.
- BLOCK**—*See* CYLINDER BLOCK.
- BLOWBY**—Leakage of the compressed fuel-air mixture or burned gases from combustion, passing the piston and rings, and into the crankcase.
- BLOWER**—A mechanical device for compressing and delivering air to the engine at higher than atmospheric pressure.
- BODY**—The assembly of sheet metal sections, framework, doors, windows, etc, which provides an enclosure for passengers or carriage space for freight.
- BOGIE**—A suspension unit consisting of tandem axles jointed by a single cross support (trunnion axle) that also acts as a vertical pivot for the entire unit.
- BOILING POINT**—The temperature at which a liquid boils.
- BOND**—To bind together.
- BORE**—The diameter of an engine cylinder hole. Also, the diameter of any hole; for example, the hole into which a bushing is fitted.
- BOSS**—An extension or strengthened section, such as the projections within a piston which supports the piston pin.
- BOURDON TUBE**—A hollow circular-shaped tube used as the pressure-sensing element in some gages.
- BOYLE'S LAW**—The absolute pressure of a fixed mass of gas varies inversely as the volume, provided the temperature remains constant.
- BRAKE ANCHOR**—A steel pin-shaped stud, rigidly mounted to the backing plate, upon which the brake shoe either is attached or rests against.
- BRAKE BACKING PLATE**—A rigid steel plate upon which certain brake components are attached.
- BRAKE BAND**—A flexible band, usually made of metal with an inner lining of brake fabric, that is tightened on a drum to slow or stop drum rotation.
- BRAKE, DISK TYPE**—A braking network consisting of a rotating disk that is restrained during application by stationary brake pads mounted on both sides of the disk.
- BRAKE DRUM**—A metal drum mounted on a car wheel or other rotating members. Brake shoes or a brake band is mechanically forced against the brake drum, causing it to slow or stop.
- BRAKE FADE**—A reduction in the coefficient of friction between retarding members as a result of excessive heat buildup.
- BRAKE FLUID**—A compounded fluid used in hydraulic brake systems. It transmits hydraulic force from the brake master cylinder to the wheel cylinder.
- BRAKE HORSEPOWER**—The power actually delivered by an engine that is available for driving the vehicle.
- BRAKE HOSE**—A tubular hose used to transmit fluid pressure when a flexible joint is required.
- BRAKE LINE**—A rigid tube used to carry brake fluid.
- BRAKE LINING**—A special woven fabric material with which brake shoes or brake bands are lined: it withstands high temperatures and pressures.
- BRAKES**—The mechanism that slows or stops a vehicle or mechanism when a pedal or other control is operated. Also called the brake system.

BRAKE SHOES—The curved metal part, faced with brake lining, that is forced against the brake drum to produce the braking or retarding action.

BRAKE SYSTEM—The system on a vehicle that slows or stops it as a pedal or lever is operated.

BREAKER POINTS—An adjustable cam-operated switch inside the distributor used to trigger the ignition coil.

BRONZE—An alloy consisting essentially of copper and tin.

BRUSHES—The carbon or carbon and metal parts in a motor or generator that contact the rotating armature commutator or rings.

BTDC—Before top dead center.

BUSHING—A sleeve placed in a bore to serve as a bearing surface.

BYPASS—A separate passage that permits a liquid, gas, or electric current to take a path other than that normally used.

CAB—A separate driver's compartment provided on some self-propelled equipment.

CALIPER—A disk brake component used to house the actuating piston(s) and brake pads.

CAM-GROUND—A process by which a piston is ground slightly egg-shaped and, when heated, becomes round.

CAMBER—The amount in inches or degrees that the front wheels of an automotive vehicle are tilted from a true vertical at the top.

CAMSHAFT—A shaft with cam lobes used to operate valves.

CAM—An irregular shaped moving part that is designed to move or alter the motion of another part.

CAPACITANCE—That property of a circuit that opposes a change in voltage and tends to increase the amount of current flowing in a circuit for a given voltage.

CAPACITOR (CONDENSER)—A device for inserting the property of capacitance into a circuit; two or more conductors separated by a dielectric.

CARBON MONOXIDE—A colorless, odorless, tasteless, deadly gas found in engine exhaust. This gas is formed by incomplete burning of hydrocarbons.

CARBURETOR—The device in a gasoline engine fuel system that mixes fuel and air and delivers the combustible mixture to the intake manifold.

CASTER—The amount in degrees that the steering knuckle pivots on an automotive vehicle are tilted forward or backward from a true vertical.

CASTING—Pouring metal into a mold to form an object.

CATALYTIC CONVERTER—A device used on some exhaust systems to reduce harmful emissions.

CAVITATION—A localized gaseous condition within a liquid stream that occurs where the pressure is reduced to the vapor pressure.

CELL—A combination of electrodes and an electrolyte that converts chemical energy into electrical energy; two or more cells connected together form a battery.

CELSIUS—The temperature scale using the freezing point of water as zero and the boiling point as 100, with 100 equal divisions between, called degrees. This scale was formerly known as the centigrade scale.

CENTER STEERING LINKAGE—A steering system configuration using two tie rods connected to the steering arms and to a central idler arm; the idler arm pivots on the frame on one end and is connected to the drag link on the other.

CENTIGRADE—(See CELSIUS.)

CENTRIFUGAL ADVANCE—The mechanism in an ignition distributor by which the spark is advanced or retarded as the engine speed varies.

CENTRIFUGAL FORCE—A force exerted on a rotating object in a direction outward from the center of rotation.

CFM—Cubic feet per minute.

CHARGE INDICATOR—The device on a vehicle that indicates, by a needle, whether or not the battery is receiving a charge from the generator or alternator.

CHARGING RATE—The rate of flow, in amperes, of electric current flowing through a battery while it is being charged.

CHARLES'S LAW—If the pressure is constant, the volume of dry gas varies directly with the absolute temperature.

CHASSIS—An assembly of mechanisms, attached to a frame, that make up the major operating parts of an automotive vehicle (less the body).

CHEMICAL CHANGE—A change that alters the composition of the molecules of a substance.

CHOKE—A device in a carburetor that blocks off, or reduces, the flow of air into the intake manifold. This produces a partial vacuum in the intake manifold and a consequent richer fuel-air mixture.

CHOKE STOVE—A device used to draw heat from around the exhaust manifold into the carburetor during engine warmup.

CID—Cubic inch displacement.

CIRCUIT—A closed path or combination of paths through which passage of the medium (electric current, air, liquid, etc) is possible.

CIRCUIT BREAKER—In electric circuits, a device designed to break or open the circuit when certain conditions exist.

CLEARANCE—A given amount of space between two parts.

CLOCKWISE—The direction of movement, usually rotary, which is the same as movement of hands on the face of a clock.

CLUTCH—The mechanism in an automotive vehicle, located in the power train, that connects the engine to, or disconnects the engine from, the remainder of the power train.

COIL—In electrical circuits, turns of wire, usually on a core and enclosed in a case, through which electric current passes.

COIL SPRING—A type of spring made of an elastic metal such as steel, formed into a wire or bar and wound into a coil.

COMBUSTION—A chemical action, or burning; in an engine, the burning of a fuel-air mixture in the combustion chamber.

COMBUSTION CHAMBER—The space at the top of the cylinder and in the head in which combustion of the fuel-air mixture takes place.

COMMUTATION—The process of converting alternating current that flows in the armature windings of direct current generators into direct current.

COMMUTATOR—A mechanical device that reverses armature connections in a motor or generator at the proper instant so that current continues to flow in one direction only.

COMPENSATING PORT—A small hole in the brake master cylinder to permit fluid to return to the reservoir.

COMPRESSIBILITY—The change in volume of a unit volume of a fluid when it is subjected to a unit change of pressure.

COMPRESSION—The act of pressing into a smaller space or reducing in size or volume by pressure.

COMPRESSION RATIO—The ratio between the volume in a cylinder with the piston at bottom dead center and with the piston at top dead center.

COMPRESSION RINGS—The upper rings on a piston. They are designed to hold the compression in the cylinder and prevent blowby.

COMPRESSION STROKE—The piston stroke from bottom dead center to top dead center during which both valves are closed and the gases in the cylinder are compressed.

COMPRESSOR—A device that converts mechanical force and motion into pneumatic fluid power.

COMPUTER—A device capable of accepting information, applying prescribed processes to the information, and supplying the results of these processes.

CONCENTRIC—Having a common center, as circles or spheres, one within the other.

CONDENSE—To transform a vapor into a liquid.

CONDENSATION—The change from a gaseous (or vapor) state to a liquid state.

CONDENSER—(1) A unit used in air-conditioning and refrigeration systems that removes heat of compression from a gas to return it to a liquid state. (2) *See also* CAPACITOR.

CONDUCTOR—A material through which electricity will flow readily.

CONNECTING ROD—The linkage between the crankshaft and piston, usually attached to the piston by a piston pin and to the journal on the crankshaft by a split bearing and bearing cap.

CONTAMINANT—Detrimental matter in a fluid.

CONTINUITY EQUATION—The mass rate of fluid flow into any fixed space is equal to the mass flow rate out. Hence, the mass flow rate of fluid past all cross sections of a conduit is equal.

CONTROL—A device used to regulate the function of a component or system.

CONTROL, CYLINDER—A control in which a fluid cylinder is the actuating device.

CONTROL, ELECTRIC—A control actuated electrically.

CONTROL, HYDRAULIC—A control actuated by a liquid.

CONTROL, MANUAL—A control actuated by the operator.

CONTROL, MECHANICAL—A control actuated by linkages, gears, screws, cams, or other mechanical elements.

CONTROL, PNEUMATIC—A control actuated by air or other gas pressure.

CONTROL RACK—A toothed rod inside mechanical injectors that rotates the pump plunger to control the quantity of injected fuel.

CONTROL, SERVO—A control actuated by a feedback system that compares the output with the reference signal and makes corrections to reduce the difference.

CONTROLS, PUMP—Controls applied to positive-displacement variable delivery pumps to adjust their volumetric output or direction of flow.

CONVERGENT—That which inclines and approaches nearer together, as the inner walls of a tube that is constricted.

COOLANT—The liquid that circulates in an engine cooling system that reduces heat generated by the engine.

COOLER—A heat exchanger, which removes heat from a fluid.

COOLER, AFTERCOOLER—A device that cools a gas after it has been compressed.

COOLER, INTERCOOLER—A device that cools a gas between the compressive steps of a multiple stage compressor.

COOLER, PRECOOLER—A device that cools a gas before it is compressed.

COOLING FAN—The fan in the engine cooling system that provides a forced circulation of air through the radiator or around the engine cylinders so that cooling is affected.

COOLING FINS—The thin metal projections on the air-cooled engine cylinder and head that greatly increase the heat-radiating surfaces and helps provide cooling of the engine cylinder.

COOLING SYSTEM—A system that reduces heat generated by the engine and thereby prevents engine overheating. In a liquid-cooled engine, it includes the engine water jackets, radiator, cooling, and water pump.

CORE—An iron mass, generally the central portion of a coil or electromagnet or armature around which the wire is coiled.

CORROSION—The slow destruction of materials by chemical agents and electromechanical reactions.

COUNTERBALANCE—A weight attached to a moving part so it will be in balance.

COUNTERCLOCKWISE—The direction of movement, usually rotary, which is opposite in direction to movement of hands on the face of a clock.

COWL—The front portion of the vehicle body or cab that partially encloses the dash panel and forms the windshield frame.

CRANK—A device for converting reciprocating motion into rotary motion, and vice versa.

CRANKCASE—The lower part of the engine in which the crankshaft rotates. In automotive practice, the upper part of the crankcase is the lower section of the cylinder block, while the lower section is the oil pan.

CRANKCASE BREATHER—The opening or tube that allows air to enter the crankcase and thus permits crankcase ventilation.

CRANKCASE DILUTION—Dilution of the lubricating oil in the oil pan by liquid gasoline seeping down the cylinder walls past the piston rings.

CRANKCASE VENTILATION—The circulation of air through the crankcase, which removes water and other vapors, thereby preventing the formation of sludge and other unwanted substances.

CRANKING MOTOR—*See* STARTER.

CRANKSHAFT—The main rotating member or shaft of the internal-combustion engine, with cranks (throws) to which the connecting rods are attached.

CYCLE—A series of events with a start and finish during which a definite chain of events takes place. In an internal-combustion engine, four piston strokes (or two piston strokes on two-stroke-cycle engine) complete the working process and produce power.

CYLINDER—A device that converts fluid power into linear mechanical force and motion. It usually consists of a movable element, such as a piston and piston rod, plunger, or ram, operating within a cylindrical bore. In an engine, it is the tubular opening in which the piston moves up and down.

CYLINDER BLOCK—That part of an engine to which, and in which, other engine parts and accessories are attached or assembled.

CYLINDER, CUSHIONED—A cylinder with a piston-assembly deceleration device at one of both ends of the stroke.

CYLINDER, DOUBLE-ACTING—A cylinder in which fluid force can be applied to the movable element in either direction.

CYLINDER, DOUBLE-ROD—A cylinder with a single piston and a piston rod extending from each end.

CYLINDER, DUAL-STROKE—A cylinder combination that provides two working strokes.

CYLINDER HEAD—The part of an engine that covers the cylinder bores. It contains water jackets (on liquid-cooled engines) and valves (on I-head engines).

CYLINDER, PISTON—A cylinder in which the movable element has a greater cross-sectional area than the piston rod.

CYLINDER, PLUNGER—A cylinder in which the movable element has the same cross-sectional area as the piston rod.

CYLINDER, SINGLE-ACTING—A cylinder in which the fluid force can be applied to the movable element in only one direction.

CYLINDER, SINGLE-ROD—A cylinder with a piston rod extending from one end.

CYLINDER SLEEVE—A pipe-shaped removable insert used as the cylinder wall on some engines.

CYLINDER, SPRING-RETURN—A cylinder in which a spring returns the piston assembly.

CYLINDER, TANDEM—Two or more cylinders with interconnected piston assemblies.

CYLINDER, TELESCOPING—A cylinder with nested multiple tubular rod segments which provide a long working stroke in a short retracted envelope.

DAMPER—A device for reducing the motion or oscillations of moving parts, air, or liquid.

DASH PANEL—The partition that separates the driver's compartment from the engine compartment. Sometimes called firewall.

DC—Direct current, or current that flows in one direction only.

DEAD AXLE—An axle that simply supports and does not turn or deliver power to the wheel or rotating member.

DECELERATION—The process of slowing down; opposite of acceleration.

DEGASSER—A device used in connection with carburetors for shutting off the flow of fuel during deceleration so that gases from incomplete combustion during deceleration are prevented.

DENSITY—The weight per unit volume of a substance.

DESICCANT—A substance used to absorb and retain moisture.

DETONATION—In an internal-combustion engine, excessively rapid burning of the compressed fuel-air mixture so that knocking results.

DIAGRAM, COMBINATION—A drawing using a combination of graphical, cutaway, and pictorial symbols.

DIAGRAM, CUTAWAY—A drawing showing principal internal parts of all components, controls, and actuating mechanisms, all interconnecting lines and functions of individual components.

DIAGRAM, GRAPHICAL—A drawing or drawings showing each piece of apparatus including all interconnecting lines by approved standard symbols.

DIAGRAM, PICTORIAL—A drawing showing each component in its actual shape according to the manufacturer's installation.

DIAGRAM, SCHEMATIC—(See **DIAGRAM, GRAPHICAL**.)

DIAPHRAGM—A flexible membrane, usually made of fabric and rubber, in hydraulic and pneumatic components.

DIESEL ENGINE—An engine using the diesel cycle of operation. Air alone is compressed in the cylinder and diesel fuel is injected at the end of the compression stroke. Heat of compression produces ignition.

DIESELING—A condition in which an engine continues to run after the ignition is turned off. Also referred to as engine run-on.

DIFFERENTIAL—A mechanism between the axles that permits one axle to turn at a different speed than the other and, at the same time, transmits power from the driving shaft to the axles.

DIFFUSER—A duct of varying cross section designed to convert a high-speed gas flow into low-speed at an increased pressure.

DIODE—A device that permits current flow in one direction and resists flow in the other.

DISC BRAKE—A braking network that uses a rotating disk called a rotor and stationary brake pads such that when forced together perform a retarding action.

DISPLACEMENT—The total amount of air or liquid an object consumes or moves while moving from one location to another.

DISTRIBUTION TUBES—Tubes in the cooling system used to direct coolant flow to vital areas.

DISTRIBUTOR—See **IGNITION DISTRIBUTOR**.

DIVERGENT—Moving away from each other, as the inner wall of a tube that flares outward.

DOHC—Double overhead camshaft.

DRAG LINK—An intermediate link in the steering system between the pitman arm and an intermediate arm, or drag-link arm.

DRIVE SHAFT—A shaft used to transmit rotary motion. In an automotive drive train, the drive shaft transmits power from the transmission to the differential. Also called the propeller shaft.

DROP FORGED—A part that has been formed by heating until red hot and pounding with a hammer.

DRY SLEEVE—A cylinder sleeve that is supported its entire length by the block and coolant does not contact the sleeve.

DRY SUMP—A lubricating system that uses a scavenger pump to collect oil and transfer it to an auxiliary container or sump.

DUAL IGNITION—An ignition system using two spark plugs for each cylinder so that a dual spark effect takes place, driving each power stroke.

DYNAMOMETER—A device for measuring the power output of an engine.

ECCENTRIC—Offcenter; as in the eccentrics (lobes) on a camshaft.

EDDY CURRENTS—Currents that are induced in a conducting material that are caused by a varying magnetic field.

EFFICIENCY—The ratio between the effect produced and the power expended to produce the effect.

ELECTRIC BRAKES—A brake system that uses electric current for energization.

ELECTRICAL SYSTEM—The system that provides the necessary input power to operate such components. In an automotive vehicle, the system that electrically cranks the engine for starting, furnishes high-voltage sparks to the engine cylinders to fire compressed fuel-air charges, lights the lights, and operates heater motor, radio, etc. It consists, in part, of the starter, wiring, battery, alternator, alternator regulator, ignition distributor, and ignition coil.

ELECTRICITY—A form of energy that involves the movement of electrons from one place to another, or the gathering of electrons in one area.

ELECTRODE—Either terminal of an electric source; either conductor by which the current enters and leaves an electrolyte.

ELECTROLYTE—A solution that is capable of conducting electricity. It may be in the form of either a liquid or paste.

ELECTROMAGNET—A temporary magnet constructed by winding a number of turns of insulated wire into a coil or around an iron core. It is energized by a flow of electric current through the coil.

- ELECTRON**—A negative-charged particle that is a basic constituent of matter and electricity. Movement of electrons is an electric current.
- EMF (ELECTROMOTIVE FORCE)**—The force that causes electricity to flow between two points with different electrical charges or when a difference of potential exists between two points. The unit of measurement is volts.
- EMISSIONS**—Products of automotive engine combustion that are released into the atmosphere.
- ENERGY**—The capacity for performing work.
- ENGINE**—An assembly that burns fuel to produce power; sometimes referred to as a powerplant.
- EQUILIBRIUM**—A state of balance between opposing forces or actions.
- ETHYLENE GLYCOL**—A solution added to anti-freeze to help prevent freezing.
- EVAPORATION**—The action that takes place when a liquid changes to a vapor or gas.
- EVAPORATOR**—A component in an air-conditioning system that is used to absorb heat from a passing airstream, thus changing the liquid flowing within into a vapor.
- EXHAUST MANIFOLD**—That part of an engine that provides a series of passages through which burned gases from the engine cylinders may flow.
- EXHAUST STROKE**—The piston stroke from bottom dead center to top dead center during which the exhaust valve is opened so that burned gases are forced from the engine cylinder into the exhaust manifold.
- EXHAUST VALVE**—The valve that opens to allow the burned gases to escape from the cylinder during the exhaust stroke.
- EXPANSION TANK**—A tank, separate from the radiator, used to compensate for expansion and contraction of engine coolant. Also called an overflow tank.
- EXPANSION VALVE**—A component used on some air-conditioning systems to control flow and reduce pressure of the refrigerant flowing into the evaporator.
- F-HEAD**—A type of engine with valves arranged to form an F; one valve is in the head, the other is in the cylinder block.
- FAHRENHEIT**—The temperature scale using the freezing point of water as 32 and the boiling point as 212, with 180 equal divisions between, called degrees.
- FAN**—*See* COOLING FAN.
- FEEDBACK**—A transfer of energy from the output of a device to its input.
- FERROUS METAL**—A metal that contains iron or steel.
- FIELD**—In a generator or electric motor, the area in which a magnetic flow occurs.
- FIELD COIL**—A coil of wire, wound around an iron core, that produces the magnetic field in a generator or motor when current passes through it.
- FIELD FRAME**—The frame in a generator or motor into which the field coils are assembled.
- FIELD WINDING**—*See* FIELD COIL.
- FILAMENT**—A fine wire inside a light bulb that emits light when current passes through it.
- FILTER**—A device whose primary function is the retention by a porous media of insoluble contaminants from a fluid.
- FILTER ELEMENT**—The porous device that performs the actual process of filtration.
- FILTER MEDIA, SURFACE**—Porous materials that primarily retain contaminants.
- FILTER MEDIA**—The porous materials that perform the actual process of filtration.
- FINAL DRIVE**—That part of an automotive power train that carries the driving power to the differential assembly. It consists of a pinion gear and a ring gear.
- FIREWALL**—The partition between the engine compartment and driver's compartment.
- FIRING ORDER**—The order in which respective cylinders of an engine deliver their power strokes.
- FLASH POINT**—The temperature to which a liquid must be heated under specified conditions of the test method to give off sufficient vapor to form a mixture with air that can be ignited momentarily by a specified flame.
- FLOAT**—In a carburetor, the metal shell that is suspended by the fuel in the float bowl and controls a needle valve that regulates the fuel level in the

bowl. When used with a liquid-level gauge, it is the apparatus (metal or cork) that is suspended by the liquid and actuates the gauge needle via mechanical linkage or other devices.

FLOAT BOWL—A section in the carburetor used as a reservoir for gasoline and in which the float is placed.

FLOAT CIRCUIT—In a carburetor, the circuit that controls entry of fuel and fuel level in the float bowl.

FLOAT LEVEL—The height of fuel in the carburetor as set by the float.

FLOW, LAMINAR—A flow situation in which fluid moves in parallel layers (also referred to as streamline flow).

FLOW, METERED—Flow at a controlled rate.

FLOW RATE—The volume, mass, or weight of a fluid passing through any conductor per unit of time.

FLOW, TURBULENT—A flow situation in which the fluid particles move in a random manner.

FLOWMETER—An instrument used to measure quantity or the flow rate of a fluid motion.

FLUID—A liquid or a gas.

FLUID COUPLING—A coupling in the power train that connects between the engine and other power train members through a fluid.

FLUID, FIRE-RESISTANT—A fluid difficult to ignite, which shows little tendency to propagate flame.

FLUID FLOW—The stream or movement of a fluid, or the rate of its movement.

FLUID FRICTION—Friction due to the viscosity of fluids.

FLUID, HYDRAULIC—A fluid suitable for use in a hydraulic system.

FLUID, PETROLEUM—A fluid composed of petroleum oil. It may contain additives.

FLUID, PHOSPHATE ESTER BASE—A fluid that contains a phosphate ester as one of the major components.

FLUID POWER—Energy transmitted and controlled through the use of fluids under pressure.

FLUID POWER SYSTEM—A system that transmits and controls power through use of a pressurized fluid within an enclosed circuit.

FLUID, SILICONE—A fluid composed of silicones. It may contain additives.

FLUID STABILITY—Resistance of a fluid to permanent change in properties.

FLUID, WATER-GLYCOL—A fluid whose major constituents are water and one or more glycols or polyglycols.

FLUX—Lines of magnetic force moving through a magnetic field.

FLYWHEEL—The rotating metal wheel attached to the crankshaft of an engine to level out the power surges from the power strokes. It also serves as part of the clutch for manual transmissions and houses the ring gear for the engine starter.

FOOT-POUND—The amount of work accomplished when a force of 1 pound produces a displacement of 1 foot.

FORCE—The action of one body on another tending to change the state of motion of the body acted upon.

FOUR-STROKE-CYCLE ENGINE—An engine that requires four piston strokes (intake, compression, power, exhaust) to make the complete cycle of events in the engine cylinder.

FRAME—An assembly of metal structural parts and channel sections that support the engine and body and that is supported by the vehicle wheels.

FREE ELECTRONS—Electrons in the outer orbits of an atom that are easily moved out of orbit.

FREE FLOW—Flow that encounters negligible resistance.

FREON-12—A refrigerant used in air-conditioning and refrigeration systems. Also called refrigerant-12 or R-12.

FREQUENCY—The number of vibrations, cycles, or changes in direction in a unit of time.

FRICTION—The resistance to motion between two bodies in contact with each other.

FRICTION BEARING—A bearing having no moving parts. The shaft that rotates simply rubs against or rides on a thin film of oil between the bearing and shaft.

- FRICITION PRESSURE DROP**—The decrease in the pressure of a fluid flowing through a passage attributable to the friction between the fluid and the passage walls.
- FUEL**—The substance that is burned to produce heat and create motion of the piston on the power stroke in an engine.
- FUEL FILTER**—A device placed in the fuel line of the fuel system to remove dirt and other harmful impurities.
- FUEL GAGE**—An indicating device in the fuel system that indicates the amount of fuel in the fuel tank.
- FUEL INJECTION**—A fuel delivery system that sprays fuel either directly into the cylinders or into the intake manifold just ahead of the cylinders.
- FUEL LINE**—The tube or tubes connecting the fuel tank and other fuel system components and through which the fuel passes.
- FUEL PUMP**—The mechanism in the fuel system that transfers fuel from the fuel tank to the carburetor or fuel injection system.
- FUEL TANK**—The storage tank for fuel on the vehicle.
- FULCRUM**—The support, as a wedge-shaped piece or a hinge, about which a lever turns.
- FULL-FLOATING AXLE**—An axle that is designed only to deliver power to the wheel. Vehicle weight and wheel retaining are accomplished by other members.
- FUSE**—A circuit-protecting device that makes use of a substance that has a low melting point. The substance melts if an overload occurs, thus protecting other devices in the system.
- FUSIBLE LINK**—A length of special wire inserted in a circuit to protect against excessive current draw.
- GAS**—The form of matter that has neither a definite shape nor a definite volume.
- GASKET**—A class of seals that provides a seal between two stationary parts.
- GASOLINE**—A hydrocarbon, obtained from petroleum, that is suitable as an internal-combustion engine fuel.
- GAUGE**—An instrument or device for measuring, indicating, or comparing a physical characteristic.
- GAUGE, BELLOWS**—A gauge in which the sensing element is a convoluted closed cylinder. A pressure differential between the outside and the inside causes the cylinder to expand or contract axially.
- GAUGE, BOURDON TUBE**—A pressure gauge in which the sensing element is a curved tube that tends to straighten out when subjected to internal fluid pressure.
- GAUGE, DIAPHRAGM**—A gauge in which the sensing element is relatively thin and its inner portion is free to deflect with respect to its periphery.
- GAUGE, PRESSURE**—A gauge that indicates the pressure in the system to which it is connected.
- GAUGE PRESSURE**—Pressure above atmospheric pressure.
- GAUGE SNUBBER**—A device installed in the line to the pressure gauge used to dampen pressure surges and thus provide a steady reading and a protection for the gauge.
- GAUGE, VACUUM**—A pressure gauge for pressures less than atmospheric.
- GEAR RATIO**—The relative speeds at which two gears turn; the proportional rate of rotation.
- GEARSHIFT**—A mechanism by which the gears in a transmission system are engaged.
- GEARS**—Mechanical devices to transmit power or turning effort, from one shaft to another; more specifically, gears that contain teeth that engage or mesh upon turning.
- GENERATOR**—A machine that changes mechanical energy to electrical energy. A machine that produces ac or dc voltage, depending on the design.
- GLOW PLUG**—An electrical device placed in some diesel engines that heats up when activated to aid in cold weather starting.
- GOVERNOR**—A mechanism that controls speed or other variables. Specifically, speed governors used on automotive vehicles to prevent excessive engine speed by controlling actions in the carburetor or fuel injection system.
- GRAVITY**—The force that tends to draw all bodies toward the center of the earth. The weight of a body is the resultant of gravitational force acting on the body.

GRID—A lead screen or plate to which battery plate material is attached.

GROUND—(1) The point in an electrical circuit used as a common reference point for measuring purposes. (2) To connect some point in an electrical circuit or some item of electrical equipment to earth or to the conducting medium used in lieu thereof, as in connecting an electrical unit to the engine or frame to return the current to its source.

GUSSET PLATE—A plate at the joint of a frame structure of steel to strengthen the joint.

HALON 1211—(A fire fighting agent) A colorless gas with a faintly sweet smell. It will not conduct electricity and is primarily used on class “B” or “C” fires. The byproducts decompose at temperatures above 900°F which leaves a sharp, irritating odor.

HAND BRAKE—A brake operated by hand. Also referred to as the parking brake.

HEAD—The height of a column or body of fluid above a given point expressed in linear units. Head is often used to indicate gauge pressure. Pressure is equal to the height times the density of the fluid.

HEAD, FRICTION—The head required to overcome the friction at the interior surface of a conductor and between fluid particles in motion. It varies with flow, size, type, and condition of conductors and fittings, and fluid characteristics.

HEAD, STATIC—The height of a column or body of fluid above a given point.

HEAD, VELOCITY—The equivalent head through which the liquid would have to fall to attain a given velocity. Mathematically it is equal to the square of the velocity (in feet) divided by 64.4 feet per second square.

HEADLIGHT—Lights at the front of the vehicle designed to illuminate the road ahead when the vehicle is traveling forward.

HEAT CROSSOVER—A passage from one exhaust manifold under carburetor to the other manifold to provide heat to the base of carburetor during warmup.

HEAT EXCHANGER—A device used to cool or heat by transferring heat from one object to another.

HEAT STOVE—A metal shroud around the exhaust manifold or intake manifold that supplies the carburetor with warm air when needed.

HELICAL—In the shape of a helix, which is the shape of a screw thread or coil spring.

HERRINGBONE GEARS—Gears having teeth machined in a V-configuration.

HIGH-SPEED CIRCUIT—In a carburetor, the passages through which fuel flows when the throttle valve is fully opened.

HIGH TENSION—Another term for high voltage. In the electrical system, refers to the ignition secondary circuit since this circuit produces high-voltage surges to cause sparking at the spark plugs.

HORN—An electrical signaling device on the vehicle.

HORSEPOWER—A measure of a definite amount of power. One horsepower equals 550 foot pound per second. To calculate horsepower: $\text{Horsepower} = \text{Power (in ft-lb per min)} \div 33,000$.

HYDRAULIC BRAKES—A braking system that uses a fluid to transmit hydraulic pressure from a master cylinder to wheel cylinders, which then cause brake shoe movement and braking action.

HYDRAULICS—Engineering science pertaining to liquid pressure and flow.

HYDRAULIC VALVE TAPPET—A valve tappet that, by means of hydraulic pressure, maintains zero valve clearance so that valve noise is reduced.

HYDROCARBON—A mixture of hydrogen and carbon found in vehicle emissions.

HYDROMETER—A device to determine the specific gravity of a liquid. This indicates the freezing point of the coolant in a cooling system or, as another example, the state of charge of a battery.

HYDROPNEUMATICS—Pertaining to the combination of hydraulic and pneumatic fluid power.

HYDROSTATICS—Engineering science pertaining to the energy of liquids at rest.

HYDROVAC BRAKES—A type of braking system using vacuum to assist in brake operation. The vacuum action reduces the effort required from the driver to operate the vehicle brakes.

I-HEAD—A type of engine with valves in the cylinder head.

IDLE—The engine speed when the accelerator pedal is fully released; generally assumed to mean when the engine is doing no work.

- IDLE CIRCUIT**—The circuit in the carburetor through which fuel is fed when the engine is idling.
- IDLER ARM**—A steering system component designed to support one end of the center link.
- IDLER GEAR**—A gear placed between a driving and a driven gear to make them rotate in the same direction. It does not affect the gear ratio.
- IDLING ADJUSTMENT**—The adjustment made on the carburetor to alter the fuel-air mixture ratio or engine speed on idle.
- IGNITION**—The action of setting fire to. In an engine, the initiating of the combustion process in the engine cylinders.
- IGNITION ADVANCE**—Refers to the spark advance produced by the distributor in accordance with engine speed and intake manifold vacuum.
- IGNITION COIL**—The component of the ignition system that acts as a transformer and steps up battery voltage to many thousand volts. The high voltage then produces a spark at the spark plug gap.
- IGNITION DISTRIBUTOR**—The component of the ignition system that closes and opens the circuit between the battery and ignition coil, and distributes the resultant high-voltage surges from the coil to the proper spark plugs.
- IGNITION SWITCH**—The switch in the ignition system that can be operated to open or close the ignition primary circuit.
- IGNITION TIMING**—Refers to the timing of the spark at the spark plug in relation to the piston position in the engine cylinder.
- IMPACT PRESSURE**—The pressure of a moving fluid brought to rest that is in excess of the pressure the fluid has when it does not flow; that is, total pressure less static pressure. Impact pressure is equal to dynamic pressure in incompressible flow; but in compressible flow, impact pressure includes the pressure change owing to the compressibility effect.
- IMPELLER**—The rotor of a centrifugal pump.
- IMPINGEMENT**—The striking or dashing upon with a clash or sharp collision, as air impinging upon the rotor of a turbine or motor.
- IMPULSE TURBINE**—A turbine driven by a fluid at high velocity under relatively low pressure.
- IN-LINE ENGINE**—An engine in which all engine cylinders are in a single row, or line.
- INDEPENDENT SUSPENSION**—A type of suspension system designed to spring each wheel separately, therefore allowing each wheel to move independently from the other.
- INDICATED HORSEPOWER**—A measurement of engine power based on power actually developed in the engine cylinders. *See also* BRAKE HORSEPOWER.
- INDUCTION**—The action or process of producing voltage by the relative motion of a magnetic field and a conductor.
- INERTIA**—The tendency of a body at rest to remain at rest, and a body in motion to continue to move at a constant speed along a straight line, unless the body is acted upon in either case by an unbalanced force.
- INHIBITOR**—Any substance which slows or prevents chemical reactions such as corrosion or oxidation.
- INJECTOR**—The mechanism, including nozzle, that injects fuel into the engine combustion chamber.
- INSERT**—A form of screw thread insert to be placed in a tapped hole into which a screw or bolt will be screwed. The insert protects the part into which the hole was tapped, preventing enlargement due to repeated removal and replacement of the screw or bolt.
- INSULATION**—A substance that stops movement of electricity (electrical insulation) or heat (heat insulation).
- INSULATOR**—A substance (usually of glass or porcelain) that will not conduct electricity.
- INTAKE MANIFOLD**—That component of the engine that provides a series of passages from the carburetor to the engine cylinders through which fuel-air mixture can flow.
- INTAKE STROKE**—The piston stroke from top dead center to bottom dead center during which the intake valve is open and the cylinder receives a charge of fuel-air mixture.
- INTAKE VALVE**—The valve in the engine that is opened during the intake stroke to permit the entrance of fuel-air mixture into the cylinder.
- INTEGRAL**—Whole; entire; lacking nothing of completeness; included within or upon.

- INTERFERENCE**—In radio, any signal received that overrides or prevents normal reception of the desired signal. In mechanical practice, anything that causes mismating of parts so they cannot be normally assembled.
- INTERNAL GEAR**—A gear in which the teeth point inward rather than outward as with a standard spur gear.
- INTERNAL-COMBUSTION ENGINE**—An engine in which the fuel is burned inside the engine, as opposed to an external-combustion engine where the fuel is burned outside the engine, such as a steam engine.
- INVERSE PROPORTION**—The relation that exists between two quantities when an increase in one of them produces a corresponding decrease in the other.
- ION**—An electrically charged atom produced by an electrical field.
- JET**—A metered opening in an air or fuel passage to control the flow of fuel or air.
- JOURNAL**—That part of a shaft that rotates in a bearing.
- KELVIN SCALE**—The temperature scale using absolute zero as the zero point and divisions that are the same size as centigrade degrees.
- KINETIC ENERGY**—The energy that a substance has while it is in motion.
- KINETIC THEORY**—A theory of matter that assumes that the molecules of matter are in constant motion.
- KINGPIN INCLINATION**—The number of degrees that the kingpin, which supports the front wheel, is tilted from the vertical.
- KINGPIN**—The pin by which a stud axle is articulated to an axle beam or steering head.
- KNOCK**—In an engine, a rapping or hammering noise resulting from excessively rapid burning or detonation of the compressed fuel-air mixture.
- KNUCKLE**—A joint or parts carrying a hinge pin that permit one part to swing about or move in relation to another.
- L-HEAD**—A type of engine with valves in the cylinder block.
- LAMINATED**—Made up of thin sheets, leaves, or plates.
- LAMINATED LEAF SPRING**—A spring made up of leaves of graduated size.
- LANDS**—(1) Piston metal between the ring grooves. (2) The raised machined surface on a spool valve.
- LEAF SPRING**—A suspension system component made up of one or several layers of flat spring steel.
- LEAN MIXTURE**—A fuel-air mixture that has a high proportion of air and a low proportion of fuel.
- LEVER**—A rigid bar or beam of any shape capable of turning about one point, called the fulcrum; used for transmitting or changing force or motion.
- LEVERAGE**—The mechanical advantage obtained by use of lever. Also an arrangement or combination of levers.
- LINE**—A tube, pipe, or hose that is used as a conductor of fluid.
- LIQUID**—A form of matter that has a definite volume but takes the shape of its container.
- LOAD**—The power that is being delivered by any power-producing device. The equipment that uses the power from the power-producing device.
- LPG**—Liquefied petroleum gas.
- LUBRICATION**—The process of supplying a coating of oil between moving surfaces to prevent actual contact between them. The oil film permits relative movement with little frictional resistance.
- LUBRICATOR**—A device that adds controlled or metered amounts of lubricant into a fluid power system.
- LUNETTE**—An eye that hooks into a pintle assembly to tow vehicles.
- MACPHERSON STRUT**—A front end suspension system in which the wheel assembly is attached to a long telescopic strut.
- MAGNETIC CLUTCH**—An electric clutch that uses a magnetic field created by electrical current flow for engagement. Such clutches are used in air-conditioning systems.
- MAGNETIC FIELD**—The space around a magnet that the magnetic lines of force permeate.

- MAGNETIC FLUX**—A general term used to designate collectively all the electric or magnetic lines of force in a region.
- MAGNETIC POLE**—Focus of magnetic lines of force entering or emanating from magnet.
- MAGNETISM**—The property exhibited by certain substances and produced by electron motion, which results in the attraction of iron and steel.
- MAGNETO**—A device that generates voltage surges, transforms them to high-voltage surges, and distributes them to the engine cylinder spark plugs.
- MAGNET**—Any body that has the ability to attract iron.
- MAIN BEARING**—In an engine, the bearings that support the crankshaft.
- MANIFOLD**—(1) A type of fluid conductor that provides multiple connections ports. (2) *See also* INTAKE MANIFOLD OR EXHAUST MANIFOLD.
- MANOMETER**—A differential pressure gauge in which pressure is indicated by the height of a liquid column of known density. Pressure is equal to the difference in vertical height between two connected columns multiplied by the density of the manometer liquid. Some forms of manometers are U tube, inclined tube, well, and bell types.
- MASTER CYLINDER**—In a hydraulic brake system, the liquid-filled cylinder in which hydraulic pressure is developed by depressing the brake pedal.
- MATTER**—Anything that has weight and occupies space.
- MECHANICAL ADVANTAGE**—The ratio of the resisting weight to the acting force. The ratio of the distance through which the force is exerted divided by the distance the weight is raised.
- MECHANICAL EFFICIENCY**—In an engine, the ratio between brake horsepower and indicated horsepower.
- MECHANISM**—A system of parts or appliances that acts as a working agency to achieve a desired result.
- MEMBER**—Any essential part of a machine or structure.
- MESHING**—The mating or engaging of the teeth of two gears.
- METER-IN**—To regulate the amount of fluid into a system or an actuator.
- METER-OUT**—To regulate the flow of fluid from a system or actuator.
- METERING ROD**—A small rod, having a varied diameter, operated within a jet to vary the flow of fuel through the jet.
- MICRON**—A millionth of a meter or about 0.00004 inch.
- MODULATOR**—A pressure control or adjusting valve used in hydraulic systems of automatic transmissions.
- MOLECULE**—A small natural particle of matter composed of two or more atoms.
- MOTOR, ELECTRIC**—A device for converting electrical energy into mechanical energy.
- MOTOR, FIXED-DISPLACEMENT**—A motor in which the displacement per unit of output motion cannot be varied.
- MOTOR, HYDRAULIC**—A device that converts fluid power into mechanical force and motion. It usually provides rotary mechanical motion.
- MOTOR, LINEAR**—(*See* CYLINDER.)
- MOTOR, ROTARY**—A motor capable of continuous rotary motion.
- MOTOR, ROTARY LIMITED**—A rotary motor having limited motion.
- MOTOR, VARIABLE-DISPLACEMENT**—A motor in which the displacement per unit of output motion can be varied.
- MUFFLER**—In an exhaust system, a device through which the exhaust gases must pass and which greatly reduces the exhaust sounds.
- MUTUAL INDUCTION**—Induction associated with more than one circuit, as two coils, one of which induces current in the other as the current in the first changes.
- NEEDLE BEARING**—An antifriction roller-type bearing in which the rollers have a very narrow diameter in relation to their length.
- NEEDLE VALVE**—A type of valve with a rod-shaped, needle-pointed valving element body that works into a valve seat so shaped that the needle point fits into it and closes the passage. The

needle valve in the carburetor float circuit is an example.

NEGATIVE TERMINAL—The terminal from which electrons depart when a circuit is completed from this terminal to the positive terminal of a generator or battery.

NEGATIVE—A term designating the point of lower electrical potential when the potential difference between two points is considered.

NEOPRENE—A synthetic rubber highly resistant to oil, light, heat, and oxidation.

NEUTRALIZATION NUMBER—A measure of the total acidity or basicity of an oil; this includes organic or inorganic acids or bases or a combination of them.

NEUTRON—A neutral-charge particle forming part of an atom.

NO-SPIN DIFFERENTIAL—A special type of differential that prevents the spinning of one of the driving wheels even if it is resting on smooth ice.

NONFERROUS METALS—All metals containing very little or no iron.

NORTH POLE—The pole of a magnet from which the lines of force are assumed to emanate.

NOZZLE—An orifice or opening in a carburetor through which fuel feeds into the passing airstream on its way to the intake manifold.

OCTANE RATING—A measure of the antiknock value of engine fuel.

ODOMETER—The part of the speedometer that measures, accumulatively, the number of vehicle miles traveled.

OHMMETER—A device for measuring the resistance of a circuit or electrical machine.

OHM—A measure of electrical resistance. A conductor of 1-ohm resistance will allow a flow of 1 ampere of current when 1 volt is imposed on it.

OIL CONTROL RINGS—The lower rings on the piston that are designed to prevent excessive amounts of oil from working up into the combustion chamber.

OIL COOLER—A special cooling radiator through which hot oil passes. Air also passes through separate passages in the radiator, providing cooling of the oil.

OIL GAGE—An indicating device that indicates the pressure of the oil in the lubrication system. Also, a bayonet-type rod to measure oil level in the crankcase.

OIL GALLERY—A pipe or drilled passageway that transports oil from one area to another in an engine.

OIL PAN—The lower part of the crankcase in which a reservoir of oil is maintained.

OIL PUMP—The pump that transfers oil from the oil pan to the various moving parts in an engine.

OIL SLINGER—A device mounted to a revolving shaft such that any oil passing that point will be thrown outward where it will return to the point of origin.

OIL STRAINER—A strainer placed at the inlet end of the oil pump to strain out dirt and other particles, preventing these from getting into moving engine parts.

OTTO CYCLE—The four-stroke cycle composed of intake, compression, power, and exhaust strokes.

OVERFLOW TANK—A special tank in the cooling system (a surge tank) to permit expansion and contraction of engine coolant without loss.

OVERHEAD VALVE—A valve mounted in the head above the combustion chamber.

OVERLOAD BREAKER—In an electrical circuit, a device that breaks or opens a circuit if it is overloaded by a short, ground, or use of too much equipment, etc.

OVERRUNNING CLUTCH—(1) A type of drive mechanism used in a starter that transmits cranking effort but overruns freely when the engine tries to drive starter. (2) A special clutch used in several mechanism that permits a rotating member to turn freely under some conditions but not under other conditions.

OXIDATION—The process by which oxygen unites with some other substance, causing rust or corrosion.

PACKING—A class of seal that is used to provide a seal between two parts of a unit which move in relation to each other.

PARALLEL CIRCUIT—Two or more electrical devices connected to the same pair of terminals so that separate currents flow through each; electrons

have more than one path to flow from the negative to the positive terminal.

PARKING BRAKE—*See* HAND BRAKE.

PASCAL'S LAW—A pressure applied to a confined fluid at rest is transmitted with equal intensity throughout the fluid.

PCV (POSITIVE CRANKCASE VENTILATION)—A system that removes gasoline and water vapors from the engine crankcase to prevent excessive crankcase pressure and contamination of the engine oil supply.

PERIOD—The time required for the completion of one cycle.

PERIPHERY—The outside surface, especially that of a rounded object or body.

PERMANENT MAGNET—A piece of steel or alloy in which molecules are so aligned that the piece continues to exhibit magnetism without application of external influence.

PHASE—The angular relationship between two alternating currents or voltages when the voltage or current is plotted as a function of time.

PICKUP COIL—A device used in automotive electronic ignition systems that sends electrical pulses to a control unit.

PILOT—A short plug at the end of a shaft to align it with another shaft or rotating part.

PING—A metallic rattling sound produced in the combustion chamber resulting from air-fuel mixture exploding rather than burning evenly.

PINION—The smaller of two mating or meshing gears.

PINTLE ASSEMBLY—A swivel-type assembly used to engage with a lunette for towing equipment.

PIPE—A type of fluid line whose dimensions are designated by nominal (approximate) outside diameter and wall thickness.

PISTON—In an engine, the cylindrical part that moves up and down in the cylinder.

PISTON BOSS—An enlarged area around the piston pin hole.

PISTON DISPLACEMENT—The volume displaced by the piston as it moves from the bottom to the top of the cylinder in one complete stroke.

PISTON HEAD—The portion of the piston above the top ring.

PISTON LANDS—The portion of the piston between the ring grooves.

PISTON PIN—The cylindrical or tubular metal pin that attaches the piston to the connecting rod; also called wrist pin.

PISTON RING—One of the rings fitted into grooves in the piston. There are two types: compression rings and oil control rings.

PISTON ROD—*See* CONNECTING ROD.

PITMAN ARM—The arm that is a part of the steering gear. It is connected by linkage to the wheel steering knuckle.

PLANETARY GEARS—A set of gears having a set of pinions rotating around a central gear (called a sun gear).

PIVOT INCLINATION—*See* KINGPIN INCLINATION.

PLIES—Layers of rubber-impregnated fabric that make up the body of a tire.

PNEUMATICS—Engineering science pertaining to gaseous pressure and flow.

PORT—An internal or external terminus of a passage in a component.

POSITIVE—A term designating the point of higher electrical potential when the potential difference between two points is considered.

POTENTIAL—A characteristic of a point in an electric field or circuit indicated by the work necessary to bring a unit positive charge from infinity; the degree of electrification as compared to some standard (the earth, for example).

POTENTIAL DIFFERENCE—The arithmetical difference between two electrical potentials; same as electromotive force, electrical pressure, or voltage.

POTENTIAL ENERGY—The energy a substance has because of its position, its condition, or its chemical composition.

POUR POINT—The lowest temperature at which a liquid will flow under specified conditions.

POWER STEERING—A steering system that uses a fluid to produce an assisting hydraulic pressure on the steering linkage, thus reducing the steering effort on the part of the driver.

- POWER STROKE**—The piston stroke from top dead center to bottom dead center during which the fuel-air mixture burns and forces the piston down so the engine produces power.
- POWER TAKEOFF**—An attachment for connecting an engine to power-driven auxiliary machinery when its use is required.
- POWER**—The rate of doing work or the rate of expanding energy.
- POWERPLANT**—The engine or power-producing mechanism on a vehicle or equipment.
- POWER UNIT**—A combination of pump, pump drive, reservoir, controls, and conditioning components which may be required for its application.
- PREIGNITION**—Premature ignition of the fuel-air mixture being compressed in the cylinder on the compression stroke.
- PRESSURE**—The amount of force distributed over each unit of area, usually expressed in pounds per square inch.
- PRESSURE, ABSOLUTE**—The sum of atmospheric and gauge pressures.
- PRESSURE, ATMOSPHERIC**—Pressure exerted by the atmosphere at any specific location.
- PRESSURE, BACK**—The pressure encountered on the return side of a system.
- PRESSURE, DIFFERENTIAL**—The difference in pressure between any two points of a system or a component.
- PRESSURE, HEAD**—The pressure due to the height of a column or body of fluid. It is usually expressed in feet.
- PRESSURE, OPERATING**—The pressure at which a system operates.
- PRESSURE, PRECHARGE**—The pressure of compressed gas in an accumulator prior to the admission of a liquid.
- PRESSURE, PROOF**—The nondestructive test pressure in excess of the maximum rated operating pressure.
- PRESSURE, STATIC**—The pressure in a fluid at rest.
- PRESSURE SWITCH**—An electrical switch operated by the increase or decrease of fluid pressure.
- PRIMARY BRAKE SHOE**—The brake shoe installed facing the front of the vehicle; usually a self-energizing shoe.
- PRIMARY CIRCUIT**—The low-voltage part of an automotive ignition system.
- PRIMARY WINDING**—The winding of a transformer connected to the electrical power source; for example, the low-voltage winding in an ignition coil.
- PRIME MOVER**—The source of mechanical power used to drive the generator, pump or compressor.
- PRIMER**—An auxiliary fuel pump operated by hand to feed additional fuel into the engine to produce a richer mixture for starting or to purge air from the system.
- PROPELLER SHAFT**—*See* DRIVE SHAFT.
- PROTON**—A basic particle of matter having a positive electrical charge, normally associated with the nucleus of the atom.
- PSI (POUNDS PER SQUARE INCH)**—A measure of force per unit area.
- PTO (POWER TAKEOFF)**—A location on a transmission or transfer case from which an operating shaft from another unit can be driven.
- PUMP**—A device that converts mechanical force and motion into hydraulic fluid power.
- PUMP, AXIAL PISTON**—A pump having multiple pistons disposed with their axes parallel.
- PUMP, CENTRIFUGAL**—A pump that produces fluid velocity and converts it to pressure head.
- PUMP, FIXED-DISPLACEMENT**—A pump in which the displacement per cycle cannot be varied.
- PUMP, RADIAL PISTON**—A pump having multiple pistons disposed radially actuated by an eccentric element.
- PUMP, VARIABLE-DISPLACEMENT**—A pump in which the volume of fluid per cycle can be varied.
- PUSH ROD**—On overhead valve engines, it is the device that transmits motion from the camshaft and valve lifter to the rocker arm to open the valve.
- RACE**—The inner or outer ring that provides a contact surface for balls or rollers to ride on.

- RADIAL ENGINE**—An engine with each cylinder located on the radius of a circle and with all cylinders disposed around a common crankshaft.
- RADIAL TIRE**—A tire having plies parallel and at right angles to tread pattern.
- RADIAL**—Pertaining to the radius of a circle.
- RADIATOR**—A device in the cooling system that removes heat from the coolant passing through it, permitting the coolant to remove heat from the engine.
- RADIUS**—The distance from the center of a circle or from the center of rotation.
- RANKINE SCALE**—A thermometer scale based on absolute zero of the Fahrenheit scale, in which the freezing point of water is approximately 492° R.
- RATIO**—The value obtained by dividing one number by another, indicating their relative proportions.
- RECEIVER**—A container in which gas is stored under pressure as a supply source for pneumatic power.
- RECIPROCATING**—Moving back and forth, as a piston reciprocating in a cylinder.
- RECTIFIER**—An electrical device that changes alternating current to direct current.
- REFRIGERANT-12**—*See* FREON-12.
- REGULATOR**—A device used to control or maintain the output of a system at a predetermined value. For example, the regulator in an automotive electrical system, controls the output of the charging system. Regulators are also use in fluid power (hydraulic and pneumatic) systems.
- RELAY**—An electromagnetic device with one or more sets of contacts that change position (open or close) by magnetic attraction of a coil to an armature in response to voltage or amperage changes in a controlling circuit.
- RESERVOIR**—A container for storage of liquid in a fluid power system.
- RESIDUAL MAGNETISM**—The magnetism retained by a material after all magnetizing forces have been removed.
- RESISTANCE**—The opposition a device or material offers to electric current flow. The effect of resistance is to raise the temperature of the device or material carrying the current. A resistance of 1 ohm will allow a current of 1 ampere to flow through it when 1 voltage is applied.
- RESISTOR**—In an electrical system, a device made of resistance wire, carbon, or other resisting material, that has a definite value of resistance and serves a definite purpose in the system by virtue of that resistance.
- RESPONSE TIME**—The time lag between a signal input and the resulting change of output.
- RESTRICTOR**—A device that reduces the cross-sectional flow area.
- RESTRICTOR, ORIFICE**—A restrictor, the length of which is relatively small with respect to its cross-sectional area. The orifice may be fixed or variable. Variable types are non-compensated, pressure compensated, or pressure and temperature compensated.
- RETURN LINE**—A line used for returning fluid back into the reservoir or atmosphere.
- RHEOSTAT**—A variable resistor used for regulating the current in a circuit.
- RICH MIXTURE**—A fuel-air mixture with a high proportion of fuel.
- RIM**—That part of a vehicle wheel on which the tire is mounted.
- RING GEAR**—A gear in the form of a ring such as the ring gear on a flywheel or in a differential.
- ROCK POSITION**—The piston and connecting rod position (top or bottom dead center) at which the crank can rock or rotate a few degrees without appreciable movement of the piston.
- ROCKER ARM**—A device used to direct upward motion of the push rod into downward motion to open the valve. Used in overhead valve installations.
- ROD CAP**—The lower detachable part of the connecting rod that can be taken off by removing bolts or nuts so the rod can be detached from the crankshaft.
- ROD**—*See* CONNECTING ROD.
- ROLLER BEARING**—A type of bearing with rollers positioned between two races.
- ROTARY ENGINE**—A piston engine in which the crankshaft is fixed and the cylinders rotate around the crankshaft.

- RPM (REVOLUTIONS PER MINUTE)**—A measure of rotational speed.
- SAE HORSEPOWER**—A measurement based upon the number of cylinders and the cylinder diameter.
- SAE**—Society of Automotive Engineers.
- SCAVENGING**—In an internal-combustion engine, it is the cleaning or blowing out of exhaust gases in the cylinders upon completion of the power stroke.
- SEALED BEAM**—A special type of headlight in which the reflector and lens are sealed together to enclose and protect the filaments.
- SEALED BEARING**—A bearing that has been lubricated and sealed during manufacturing and cannot be lubricated during service.
- SEAT**—The surface upon which another part rests.
- SECONDARY BRAKE SHOE**—A brake shoe that is installed facing the rear of a vehicle.
- SECONDARY WIRES**—The wire from the coil to the distributor central tower and the spark plug wires in an automotive ignition system.
- SELF-ENERGIZING**—A brake shoe that develops a wedging action to assist in the braking action.
- SELF-INDUCTION**—The production of a counterelectromotive force in a conductor when its own magnetic field collapses or expands with a change in current in the conductor.
- SEMI-ELLIPTICAL SPRING**—A series of leaf springs starting with the longest on top and a number of progressively shorter springs attached below.
- SEPARATOR**—A device whose primary function is to isolate undesirable fluids and or contaminants by physical properties other than size.
- SERVO**—A device used to convert a small movement into a greater movement of force.
- SHIM**—A strip of copper or similar material, used under a bearing cap or behind a gear for example, to adjust clearance. Also used as a means to adjust or alter pressure control valves and thermostats opening pressure.
- SHOCK ABSORBER**—A device in an automotive suspension system placed at a vehicle wheel to regulate spring rebound and compression.
- SHORT CIRCUIT**—An unintentional current path between two components or a component and ground; usually caused by a malfunction.
- SHUNT**—A resistive device placed in parallel with another component to protect the component from excessive current.
- SIGHT GLASS**—A glass window in an air-conditioning system used for detection of moisture or bubbles. Also used in other systems as a liquid level indicator.
- SLIP JOINT**—In a drive train, a variable-length connection that permits the propeller shaft to change effective length. Used in a variety of other applications.
- SOHC**—Single overhead camshaft.
- SOLENOID**—An electromagnetic device that changes electrical energy into mechanical motion; based upon the attraction of a movable iron plunger to the core of an electromagnet.
- SOLID**—The form of matter that has a definite shape and a definite volume.
- SOUTH POLE**—The pole of the magnet into which it is assumed the magnetic lines of force pass.
- SPARK PLUG**—The assembly that includes a pair of electrodes which has the purpose of providing a spark gap in the engine cylinder.
- SPECIFIC GRAVITY**—The ratio of the weight of a substance to the weight of an equal volume of chemically pure water at a given temperature.
- SPEEDOMETER**—An indicating device, usually connected to the transmission, that indicates the speed of motion of the vehicle.
- SPEED**—Rate of motion.
- SPIDER**—In planetary gear sets, the frame, or part, on which the planetary gears are mounted.
- SPIRAL BEVEL GEAR**—A bevel gear having curved teeth.
- SPLINE**—A slot or groove cut in a shaft or bore; a splined shaft onto which a hub, wheel, etc, with matching splines in its bore is assembled so the two must engage and turn together.
- SPRAG CLUTCH**—A form of overrunning clutch; power can be transmitted through it in one direction but not in the other.

- SPRINGS**—Flexible or elastic members that support the weight of a vehicle.
- SPUR GEAR**—A gear with radial teeth parallel to the axis.
- STARTER SOLENOID**—An electric relay used to deliver electrical power to the starting motor.
- STARTER**—The motor in an automotive electrical system that cranks the engine to get it started.
- STATIC ELECTRICITY**—Accumulated electrical charges, usually considered to be those produced by friction.
- STATOR**—(1) The part of a torque converter that stands still as torque is being multiplied, then rotates as the turbine approaches impeller speed. (2) The stationary armature of an ac generator (alternator).
- STEADY FLOW**—A flow in which the velocity, pressure, and temperature at any point in the fluid do not vary with time.
- STEERING GEAR**—That part of the steering system, located at the lower end of the steering shaft, that carries the rotary motion of the steering wheel to the vehicle wheels for steering.
- STEERING GEOMETRY**—Refers to camber, caster, pivot inclination, toe-in, and toe-out.
- STEERING LINKAGE**—Linkage between steering gear and vehicle wheels.
- STEERING SYSTEM**—The system of gears and linkage in the vehicle that permits the driver to turn the wheels for changing the direction of vehicle movement.
- STOPLIGHT**—A red light illuminated upon application of the brake cable.
- STORAGE BATTERY**—A lead-acid electrochemical device that changes chemical energy into electrical energy. The action is reversible; electric energy supplied to the battery stores chemical energy.
- STRAINER**—A coarse filter.
- STROKE**—The movement, or the distance of the movement, in either direction, of the piston travel in an engine.
- SUN GEAR**—In a planetary gear set, the central gear.
- SUPER HEAT**—Heat added to a vapor above the temperature that caused the vapor.
- SUPPLY LINE**—A line that conveys fluid from the reservoir to the pump.
- SUPPRESSION**—In electrical systems, the elimination of stray electromagnetic waves/signals so that they cannot be detected by radio.
- SURGE**—A momentary rise of pressure in a circuit.
- SWITCH**—In electrical systems, a device used to open or complete an electrical circuit.
- SYNCHRONIZE**—To make two or more events or operations occur at the same time.
- SYNTHETIC MATERIAL**—A complex chemical compound that is artificially formed by the combining of two or more simpler compounds or elements.
- TACHOMETER**—A device for measuring revolutions per minute.
- TAILPIPE**—The exhaust piping running from the muffler to the rear of the vehicle.
- TAPPET**—A screw used to adjust clearance between the valve stem and lifter or rocker arm.
- TANK**—A container for the storage of fluid in a fluid power system.
- TDC (TOP DEAD CENTER)**—The position of an engine piston when it is at the top of its stroke.
- TEFLON**—A plastic with excellent self-lubricating (slippery) bearing properties.
- TEMPER**—To effect a change in hardness and strength of steel through heating and cooling.
- TEMPERATURE GAGE**—An indicating device in the cooling system that indicates the temperature of the coolant and gives warning if excessive engine temperatures develop.
- TENSION**—A stress caused by a pulling force.
- THEORY**—A scientific explanation, tested by observations and experiments.
- THERMAL EFFICIENCY**—The ratio between the power output and the energy in the fuel burned to produce the output.
- THERMAL EXPANSION**—The increase in volume of a substance due to temperature change.
- THERMISTOR**—A resistor whose value varies with temperature.
- THERMOSTAT**—A device for automatic regulation of temperature.

- THERMOSTATIC SWITCH**—A switch that is turned on or off by temperature change.
- THROTTLE**—A mechanism in the fuel system that permits the driver to vary the amount of fuel-air mixture entering the engine and thus control engine speed.
- THROTTLE VALVE PLATE**—The disk in the lower part of the carburetor air horn that can be tilted to pass more or less fuel-air mixture to the engine.
- THRUST BEARING**—A bearing that is designed to resist axial (sideways) forces of a rotating member.
- THRUST**—A force tending to push a body out of alinement. A force exerted endwise through a member upon another member.
- TIE ROD**—A rod connection in the steering system between wheels.
- TIMED FUEL INJECTION**—Fuel injection system that injects fuel on an individual cylinder basis and in sequence with the cylinder's intake stroke.
- TIMING**—Refers to ignition or valve timing and pertains to the relation between ignition or valve mechanism and piston position in the cylinder.
- TIMING BELT**—A flexible toothed belt that, through sprockets, drives the engine camshaft.
- TIMING CHAIN**—A link- or roller-type continuous chain that, through sprockets, drives the engine camshaft.
- TIMING GEARS**—A pair of helical gears that drive the engine camshaft.
- TIMING MARKS**—A pair of reference points that are used to obtain correct timing of the valves or ignition distributor of an engine.
- TOE-IN**—The number of inches that the front wheels of a vehicle point in toward the center of the vehicle. A measurement is obtained by measuring the distances between the front tires at the forward and rearward edges and taking the difference between the two dimensions. The measurements are taken with the wheels in the straight ahead position.
- TOE-OUT**—The difference in turning of the inner wheel, with the outer wheel turned at a 20-degree angle. The inner wheel must turn sharper than the outer, the wheels are further apart at the forward edge (toe) than the rearward edge.
- TOLERANCE**—The amount of variation permitted from an exact size or measurement; the actual amount from smallest acceptable dimension to largest acceptable dimension.
- TORQUE**—A force or combination of forces that produces or tends to produce a twisting or rotary motion.
- TORQUE CONVERTER**—A special form of fluid coupling in which torque may be increased (at expense of speed).
- TORQUE MULTIPLICATION**—A term that refers to engine torque increase that occurs within a torque converter.
- TORQUE ROD**—An arm or rod used to ensure accurate alinement of an axle with the frame and to relieve the suspension system springs of driving and braking stresses.
- TORSIONAL VIBRATION**—Vibration in a rotary direction; a portion of a rotating shaft repeatedly moves ahead, or lags behind, while the remainder of the shaft is exhibiting torsional vibration.
- TORUS**—The rotating members of a fluid coupling.
- TRANSDUCER**—A device that is actuated by power from one system and supplies power in another form to a second system.
- TRANSFER CASE**—A gearbox, driven by the transmission that will provide driving force to both front and rear propeller shafts on four-wheel drive vehicles.
- TRANSMISSION BRAKE**—A brake placed at the rear of the transmission, usually used for parking.
- TRANSMISSION**—The device in the power train that provides different gear ratios between the engine and driving wheels, as well as reverse.
- TRUNNION**—Either of two opposite pivots or cylindrical projections from the sides of a part or assembly, supported by bearings, to provide a means of swiveling or turning the part or assembly.
- TUBING**—A type of fluid line whose dimensions are designated by actual measured outside diameter and by actual measured wall thickness.
- TURBINE**—A rotary motor actuated by the reaction, impulse, or both, of a flow of pressurized fluid.
- TURBINE ENGINE**—An engine that uses the expansive force of burning gases to spin a turbine.

- TURNING RADIUS**—The diameter of the circle made by a vehicle during operation with front wheels turned fully in either direction.
- TURRET NOZZLE**—A hose nozzle that pivots and revolves on the A/S32P-25 fire fighting vehicle.
- TWO-STROKE-CYCLE ENGINE**—An internal-combustion engine requiring only two piston strokes to complete the cycle of events that produce power.
- UNIVERSAL JOINT**—A device that transmits power through an angle.
- UNSPRUNG WEIGHT**—Weight of a vehicle that is not supported by springs.
- UPDRAFT CARBURETOR**—A carburetor in which air passes through it in an upward direction.
- V-TYPE ENGINE**—An engine with two banks of cylinders set at an angle to each other in the shape of a V.
- VACUUM**—A space entirely devoid of matter.
- VACUUM ADVANCE**—The mechanism on an ignition distributor that advances the spark in accordance with vacuum in the intake manifold.
- VACUUM BRAKE**—Vehicle brakes that are actuated by vacuum under the control of the driver.
- VACUUM PUMP**—A pump, used in a vacuum brake system (for example), that produces a vacuum in a designated chamber.
- VACUUM SWITCH**—In the starting system, an electric switch that is actuated by vacuum (in the intake manifold) to open the starting system control circuit after the engine starts.
- VALVE**—A device that controls fluid flow direction, pressure, or flow rate.
- VALVE, CHECK**—A directional control valve that permits flow of fluid in only one direction.
- VALVE, COUNTERBALANCE**—A pressure control valve that maintains back pressure to prevent a load from falling.
- VALVE, DIRECTIONAL CONTROL**—A valve whose primary function is to direct or prevent flow through selected passages.
- VALVE, FLOW CONTROL**—A valve whose primary function is to control flow rate.
- VALVE, HYDRAULIC**—A valve for controlling liquid.
- VALVE, ISOLATION**—A valve used to isolate a system or components.
- VALVE, PILOT**—A valve used to operate another valve or control.
- VALVE, PNEUMATIC**—A valve for controlling gas.
- VALVE, PRESSURE REDUCING**—A pressure control valve whose primary function is to limit outlet pressure.
- VALVE, PRIORITY**—A valve that directs flow to one operating circuit at a fixed rate and directs excess flow to another operating circuit.
- VALVE, RELIEF**—A pressure control valve whose primary function is to limit system pressure.
- VALVE SEAT**—The surface, normally curved, against which the valve operating face comes to rest, to provide a seal against leakage.
- VALVE SEAT INSERT**—A metal ring inserted into the valve seat; made of special metal that can withstand operating temperature satisfactorily.
- VALVE, SELECTOR**—A directional control valve whose primary function is to selectively interconnect two or more ports.
- VALVE, SEQUENCE**—A valve whose primary function is to direct flow in a predetermined sequence.
- VALVE, SERVO**—A directional control valve that modulates flow or pressure as a function of its input signal.
- VALVE, SHUTOFF**—A valve that operates fully open or fully closed.
- VALVE SPRING**—The compression-type spring that closes the valve when the valve-operating cam assumes a closed-valve position.
- VALVE TAPPET**—The part that rides on the valve-operating cam and transmits motion from the cam to the valve stem or push rod.
- VALVE TIMING**—Refers to the timing of valve closing and opening in relation to piston position in the cylinder.
- VALVE TRAIN**—The train of moving parts that causes valve movement.

- VALVE, UNLOADING**—A pressure control valve whose primary function is to permit a pump or compressor to operate at minimum load.
- VAPOR LOCK**—A condition in the fuel system in which gasoline has vaporized, as in the fuel line, so that fuel delivery to the carburetor is blocked or retarded.
- VELOCITY**—The rate of motion or speed at any instant, usually measured in miles per hour or feet per second or minute.
- VENTURI**—A tube having a narrowing throat or constriction to increase the velocity of fluid flowing through it. The flow through the venturi causes a pressure drop in the smallest section, the amount being a function of the velocity of flow. In a carburetor, it is the restriction in the air horn that produces the vacuum responsible for the movement of fuel into the passing airstream.
- VIBRATION DAMPER**—A weighted device that is attached to the engine crankshaft at the end opposite its power output. Its purpose is to absorb engine vibration.
- VISCOSITY**—A measure of the internal friction or resistance of a fluid to flow.
- VISCOSITY INDEX**—A measure of the viscosity-temperature characteristics of a fluid as referred to that of two arbitrary reference fluids.
- VISCOSITY, KINEMATIC**—The absolute viscosity divided by the density of the fluid. It is usually expressed in centistokes.
- VISCOSITY, SAYBOLT UNIVERSAL SECONDS (SUS)**—The time in seconds, for 60 milliliters of oil to flow through a standard orifice at a given temperature.
- VOLATILITY**—A measurement of the ease with which a liquid turns to vapor.
- VOLTAGE REGULATOR**—A device used in connection with a generator to keep the voltage constant and to prevent it from exceeding a predetermined maximum.
- VOLT**—A unit of potential, potential difference, or electrical pressure.
- VOLUME OF FLOW**—The quantity of fluid that passes a certain point in a unit of time. The volume of flow is usually expressed in gallons per minute for liquids and cubic feet per minute for gases.
- VOLUMETRIC EFFICIENCY**—The ratio between the amount of fuel-air mixture that actually enters an engine cylinder and the amount that could enter under ideal conditions.
- WATER JACKET**—A jacket that surrounds the cylinders and cylinder head(s), through which coolant flows.
- WATER MANIFOLD**—A manifold used to distribute coolant to several points in the cylinder block or cylinder head.
- WATER PUMP**—In the cooling system, the pump that circulates coolant between the engine water jackets and the radiator.
- WHEEL ALINEMENT**—The mechanics of keeping all parts of the steering system in correct relation with each other.
- WHEEL BRAKE**—A brake that operates at the wheel, usually on a brake drum attached to the wheel.
- WHEEL CYLINDER**—In hydraulic brake systems, the hydraulic cylinder that operates the brake shoes when hydraulic pressure is applied in the cylinder.
- WINCH**—A mechanism actuating a drum upon which a cable is coiled, so that when a rotating power is applied to the drum, a powerful pull is produced.
- WOBBLE PLATE**—That part of a certain type of pump that drives pistons back and forth as it rotates to produce pumping action. It is a disk, or plate, set at an angle on a rotating shaft.
- WORK**—The result of a force acting against opposition to produce motion. It is measured in terms of the product of the force and the distance it acts.
- WORM GEAR**—A gear having concave, helical teeth that mesh with the threads of a worm; also called a worm wheel.

APPENDIX II

REFERENCES USED TO DEVELOP THIS NONRESIDENT TRAINING COURSE

Although the following references were current when this Nonresident Training Course was published, their continued currency cannot be assured. When consulting these references, keep in mind that they may have been revised to reflect new technology or revised methods, practices, or procedures. Therefore, you need to ensure that you are studying the latest references.

Chapter 1

Aircraft Weapons Systems Cleaning and Corrosion Control, NAVAIR 01-1A-509, Commander, Naval Air Systems Command, Washington, D.C., 01 May 2001.

Avionic Cleaning and Corrosion Prevention/Control, Organizational/Unit and Intermediate Maintenance, NAVAIR 16-1-540, Commander, Naval Air Systems Command, Washington, D.C., 1 September 2000.

Manual of Enlisted Manpower and Personnel Classifications and Occupational Standards, Volume II, Navy Enlisted Classifications (NECs), NAVPERS 18068F, Bureau of Naval Personnel, Washington, D.C., July 1996.

Naval Aviation Maintenance Program (NAMP), OPNAVINST 4790.2H, Volumes I, III, and V, Department of the Navy, Office of the Chief of Naval Operations, Washington, D.C., 02 July 2001.

Support Equipment Cleaning, Preservation, and Corrosion Control, Maintenance Instructions (Organizational and Intermediate Levels), NAVAIR 17-1-125, Commander, Naval Air Systems Command, Washington, D.C., 15 April 2001.

Chapter 2

Aeronautical and Support Equipment Welding, Intermediate and Depot Level Maintenance Instructions, NAVAIR 01-1A-34, Commander, Naval Air Systems Command, Washington, D.C., 1 April 1998.

Aircraft Towing Tractor, A/S32A-37, Operation and Intermediate Maintenance with Illustrated Parts Breakdown, NAVAIR 19-40-519, Commander, Naval Air Systems Command, Washington, D.C., 1 August 1990.

Aviation Structural Mechanic (AM), NAVEDTRA 14315, Naval Education and Training Professional Development and Technology Center, Pensacola, Florida, July 2002.

Basic Machines, NAVEDTRA 14037, Naval Education and Training Program Management Support Activity, Pensacola, Florida, February 1994.*

Construction Mechanic Basic, Volume 1, NAVEDTRA 14264, Naval Education and Training Professional Development and Technology Center, Pensacola, Florida, February 1998.

Construction Mechanic Basic, Volume 2, NAVEDTRA 14273, Naval Education and Training Professional Development and Technology Center, Pensacola, Florida, May 1999.

Power Plant, Mobile Electric, Model No. NC-8A/NC-8A-1, Operation and Maintenance Instructions with Illustrated Parts Breakdown, Organizational, Intermediate, and Depot, NAVAIR 19-45-9, Commander, Naval Air Systems Command, Washington, D.C., 1 June 1985.

Support Equipment Tire and Wheel Assemblies, Operational and Intermediate Maintenance Instructions, NAVAIR 17-1-129, Commander, Naval Air Systems Command, Washington, D.C., 1 August 1995.

Chapter 3

Construction Mechanic Basic, Volume 1, NAVEDTRA 14264, Naval Education and Training Professional Development and Technology Center, Pensacola, Florida, February 1998.

Construction Mechanic Basic, Volume 2, NAVEDTRA 14273, Naval Education and Training Professional Development and Technology Center, Pensacola, Florida, May 1999

Principles of Automotive Vehicles, TM 9-8000, Headquarters, Department of the Army, Washington, D.C., 25 October 1985.

Chapter 4

Construction Mechanic Basic, Volume 1, NAVEDTRA 14264, Naval Education and Training Professional Development and Technology Center, Pensacola, Florida, February 1998.

Construction Mechanic Basic, Volume 2, NAVEDTRA 14273, Naval Education and Training Professional Development and Technology Center, Pensacola, Florida, May 1999.

Principles of Automotive Vehicles, TM 9-8000, Headquarters, Department of the Army, Washington, D.C., 25 October 1985.

Chapter 5

Construction Mechanic Basic, Volume 1, NAVEDTRA 14264, Naval Education and Training Professional Development and Technology Center, Pensacola, Florida, February 1998.

Construction Mechanic Basic, Volume 2, NAVEDTRA 14273, Naval Education and Training Professional Development and Technology Center, Pensacola, Florida, May 1999.

Principles of Automotive Vehicles, TM 9-8000, Headquarters, Department of the Army, Washington, D.C., 25 October 1985.

Chapter 6

Aircraft Electric and Electronic Wiring, Installation Practices, NAVAIR 01-1A-505, Commander, Naval Air Systems Command, Washington, D.C., 10 August 1994.

Naval Aircraft and Naval Aircraft Support Equipment Storage Batteries, Operation and Maintenance Instructions with Illustrated Parts Breakdown, NAVAIR 17-15BAD-1, Commander, Naval Air Systems Command, Washington, D.C., 1 June 2001.

Power Plant, Mobile Electric, Model No. NC-8A/NC-8A-1, Operation and Maintenance Instructions with Illustrated Parts Breakdown, Organizational, Intermediate, and Depot, NAVAIR 19-45-9, Commander, Naval Air Systems Command, Washington, D.C., 1 June 1985.

Chapter 7

Aircraft Electric and Electronic Wiring, Installation Practices, NAVAIR 01-1A-505, Commander, Naval Air Systems Command, Washington, D.C., 10 August 1994.

Intermediate Maintenance Instructions for Repair and Assembly of Dummy Load Bank DA-675/MSM, NAVAIR 17-15BA-241, Commander, Naval Air Systems Command, Washington, D.C., 1 December 1980.

Intermediate Maintenance Instructions for Repair and Assembly of External Power Cables and Attachable Plugs, NAVAIR 17-1-116, Commander, Naval Air Systems Command, Washington, D.C., 1 July 1995.

Navy Electricity and Electronics Training Series, Module 7, *Introduction to Solid-State Devices and Power Supplies*, NAVEDTRA 14179, Naval Education and Training Program Management Support Activity, Pensacola, Florida, July 1992.*

Mobile Electric Power Plant, MMG-1A, Organizational, Intermediate, and Depot Maintenance with Illustrated Parts Breakdown, NAVAIR 19-45-19, Commander, Naval Air Systems Command, Washington, D.C., 1 April 1993.

Mobile Electric Power Plant, NC-10B1 and NC-10C, Operation and Maintenance Instructions with Illustrated Parts Breakdown, NAVAIR 19-45-20, Naval Air Systems Command, Washington, D.C., 1 July 2000.

Mobile Electric Power Plant, NC-2A, Organizational and Intermediate Maintenance with Illustrated Parts Breakdown, NAVAIR 19-45-10, Commander, Naval Air Systems Command, Washington, D.C., 31 March 1993.

Power Plant, Mobile Electric, Model No. NC-8A/NC-8A-1, Operation and Maintenance Instructions with Illustrated Parts Breakdown, Organizational, Intermediate, and Depot, NAVAIR 19-45-9, Commander, Naval Air Systems Command, Washington, D.C., 1 June 1985.

Chapter 8

Aircraft Jacks, Various, Operation and Intermediate Maintenance with Illustrated Parts Breakdown, NAVAIR 19-70-521, Commander, Naval Air Systems Command, Washington, D.C., 30 June 1999.

Aircraft Tow Tractor, A/S32A-32, Operation, Intermediate, and Depot Maintenance Instructions with Illustrated Parts Breakdown, NAVAIR 19-1-157, Commander, Naval Air Systems Command, Washington, D.C., 1 October 1998.

Aviation Hose and Tube Manual, NAVAIR 01-1A-20, Commander, Naval Air Systems Command, Washington, D.C., 1 July 1997.

Aviation Hydraulics Manual, NAVAIR 01-1A-17, Commander, Naval Air Systems Command, Washington, D.C., 15 August 1997.

Fire Fighting Vehicle A/S32P-25 Operation and Intermediate Maintenance Instructions with Illustrated Parts Breakdown, NAVAIR 19-25-514, Commander, Naval Air Systems Command, Washington, D.C., 1 August 1999.

Fluid Power, NAVEDTRA 14105, Naval Education and Training Program Management Support Activity, Pensacola, Florida, July 1990.*

Loader, Air Launched Weapons (A/S32K-1 4500 Pound Capacity Swinging Boom), Operation and Maintenance Instructions with Illustrated Parts Breakdown (Organizational, Intermediate, Depot), NAVAIR 19-15BA-39, Commander, Naval Air Systems Command, Washington, D.C., 1 December 1990.

Portable Hydraulic Power Supply, A/M27T-5, Operation, Intermediate, and Depot Maintenance Instructions with Illustrated Parts Breakdown, NAVAIR 17-15BF-89, Commander, Naval Air Systems Command, Washington, D.C., 1 November 1990.

Chapter 9

Fluid Power, NAVEDTRA 14105, Naval Education and Training Program Management Support Activity, Pensacola, Florida, July 1990.*

Nitrogen Cylinder, Portable 3000 PSI, NAVAIR 19-35-17, Commander, Naval Air Systems Command, Washington, D.C., 1 March 1991.

Nitrogen Servicing Unit, A/M26U-4, Operation and Maintenance Instructions with Illustrated Parts Breakdown (Intermediate and Depot), AG-750AO-OMM-000, Commander, Naval Air Systems Command, Washington, D.C., 1 March 1993.

Chapter 10

Aircraft Liquid Oxygen System Gas Purging Set, NAVAIR 19-25D-27, Commander, Naval Air Systems Command, Washington, D.C., 30 May 1997.

Aviation - Crew Systems Oxygen Systems (Aircraft Equipment Masks and Other Systems), NAVAIR 13-1-6.4-1, Commander, Naval Air Systems Command, Washington, D.C., 1 April 2001.

Aviators Breathing Oxygen (ABO) Surveillance Program, Laboratory Manual and Field Guide, NAVAIR A6-332AO-GYD-000, Commander, Naval Air Systems Command, Washington, D.C., 1 June 1997.

Cryogenic Sampler, AG-115SL-OMP-000, Secretary of the Air Force, Washington, D.C., 31 March 1983.

Field Handling of Liquid Breathing Oxygen, NAVAIR 06-30-501, Commander, Naval Air Systems Command, Washington, D.C., 28 February 1999.

Gas Cylinders (Storage Type) Use, Handling, and Maintenance, NAVAIR 06-20-2, Secretary of the Air Force and by Direction of Commander, Naval Air Systems Command, Washington, D.C., 15 November 1991.

Oxygen Servicing Unit, A/U26U-1, Operation and Maintenance Instructions with Illustrated Parts Breakdown, NAVAIR 19-25D-31, Commander, Naval Air Systems Command, Washington, D.C., 16 November 1999.

Servicing Trailer, Liquid Oxygen Low Loss, Closed Loop, Type TMU-70/M, NAVAIR 19-25D-26, Commander, Naval Air Systems Command, Washington, D.C., 30 October 1987.

Storage Tank, Liquid Oxygen Type TMU-27/M 50 Gallon Capacity, NAVAIR 19-25D-33, Commander, Naval Air Systems Command, Washington, D.C., 30 September 2000.

Chapter 11

Air-Conditioner, Aircraft Ground Cooling, Model A/M32C-21, Organizational and Intermediate Maintenance with Illustrated Parts Breakdown, NAVAIR AG-180AO-MMM-000, Commander, Naval Air Systems Command, Washington, D.C., 15 May 1991.

Air Conditioning, FOS Fundamentals of Service, FOS-5705B, Deere & Company, Moline, IL, Copyright 1970, 1973, 1979, 1981, 1984.

Mobile Air Conditioning Unit, Model No. A/M32C-17, Organizational, Intermediate, and Depot Maintenance with Instructions with Illustrated Parts Breakdown, NAVAIR 19-60-87, Commander, Naval Air Systems Command, Washington, D.C., 31 July 1992.

Refrigerant Recovery-Recycle System, Part Number ST-100/A-USN, ST-1000, Operation and Intermediate Maintenance with Illustrated Parts Breakdown, NAVAIR 19-60-91, Refrigerant Recovery Systems, Inc., 20 August 1998.

Chapter 12

Gas Turbine Enclosure Model GTC85, NAVAIR 19-105B-47, Commander, Naval Air Systems Command, Washington, D.C., 1 May 1991.

Gas Turbine Enclosure Model GTC85, NAVAIR 19-105B-48, Commander, Naval Air Systems Command, Washington, D.C., 1 April 1973.

Gas Turbine Enclosure Model GTC85-1, NAVAIR 19-105B-49, Commander, Naval Air Systems Command, Washington, D.C., 1 November 1972.

Gas Turbine Engine Analyzer Model UPUA4-1, NAVAIR 19-105BC-1, Commander, Naval Air Systems Command, Washington, D.C., 15 August 1961.

Jet Aircraft Start Unit A/M47A-4, NAVAIR 19-105B-59, Commander, Naval Air Systems Command, Washington, D.C., 1 May 1999.

Pneumatic and Shaft Power Gas Turbine Engine Model GTCP 100-82, A1-580AB-MMI-200, Commander, Naval Air Systems Command, Washington, D.C., 1 June 1987.

Pneumatic Starter Duct Assembly, NAVAIR 19-105B-56, Commander, Naval Air Systems Command, Washington, D.C., 15 April 1987.

A/S47A-1 (GTCP-100) Tractor Mounted Enclosure Operation and Intermediate Instruction with Illustrated Parts Breakdown, NAVAIR 19-105B-60, Commander, Naval Air Systems Command, Washington, D.C., 15 November 1991.

Chapter 13

Aircraft Crash Handling and Salvage Crane A/S32A-36, Operational and Intermediate Level Maintenance Instructions with Illustrated Parts Breakdown, NAVAIR AG-310DO-OMM-000, Commander, Naval Air Systems Command, Washington, D.C., 1 April 1998.

Forklift Truck 6000 lb Capacity, Operation, Maintenance, Repair and Overhaul with Illustrated Parts Breakdown, 0532-LP-000-4125, Commanding Officer, Navy Ships Parts Control Center, Mechanicsburg, PA, June 1993.

Lift Slings for Aircraft and Related Components, Organizational, Intermediate, and Depot Maintenance, Inspection and Proof Load Testing, NAVAIR 17-1-114, Commander, Naval Air Systems Command, Washington, D.C., 30 September 2000.

Navy Electricity and Electronics Training Series, Module 24, *Introduction to Fiber Optics*, NAVEDTRA 14196, Naval Education and Training Program Management Support Activity, Pensacola, Florida, August 1992.*

Flight Deck Scrubbers, Operation and Maintenance Manual with Parts List, SG340-AA-OMP-010, Commander Naval Sea Systems Command, Revision 1, 1 May 1995.

Fire Fighting Vehicle A/S32P-25 Operation and Intermediate Maintenance Instructions with Illustrated Parts Breakdown, NAVAIR 19-25-514, Commander, Naval Air Systems Command, Washington, D.C., 1 August 1999.

*Effective 01 October 1996, the Naval Education and Training Program Management Support Activity (NETPMSA) became the Naval Education and Training Professional Development and Technology Center (NETPDTC).

APPENDIX III

ANSWERS TO REVIEW QUESTIONS

CHAPTERS 1 THROUGH 13

CHAPTER 1

- A1-1. NAVPERS 18068 (series)*
- A1-2. 24 February 1966*
- A1-3. 7612*
- A1-4. 7616*
- A1-5. AIMD*
- A1-6. Unaccompanied overseas*
- A1-7. Clean it*
- A1-8. Preventive and corrective*
- A1-9. Calendar*
- A1-10. Only with prior approval from SECA*
- A1-11. Wiring diagrams, experience, MIM, and functional drawings*
- A1-12. Maintenance Instruction Manual and Maintenance Requirements Card*
- A1-13. Dirt and water in fuels*
- A1-14. Any temperature*
- A1-15. Antiknock, viscosity, and volatility*
- A1-16. Lower cost per gallon*
- A1-17. It forms a jelly-type substance*
- A1-18. Hydrometer*
- A1-19. Deterioration of metal by chemical or electrochemical process*
- A1-20. Wet and humid*
- A1-21. Maintaining a dry environment around support equipment*
- A1-22. NA 17-1-125*
- A1-23. None of the above*
- A1-24. Successful completion of the NAMTRAGRU Basic Corrosion Control (C-600-3180) or Avionics Corrosion Control (C-100-4176)*
- A1-25. Tracks inventory of support equipment*
- A1-26. SE Operator's license (OPNAV 4790/102) for the specific equipment*
- A1-27. The using activity*
- A1-28. Preoperational inspection record*

- A1-29. *VIDS/MAF*
- A1-30. *Squadrons*
- A1-31. *Common and peculiar nonavionics SE*
- A1-32. *Hydraulic*
- A1-33. *True*
- A1-34. *NC-10C*
- A1-35. *MMG-1A and A/S37A-3*
- A1-36. *A/M27T-7*
- A1-37. *A/M27M-10*
- A1-38. *85,000 lb*
- A1-39. *A/S32A-32*
- A1-40. *True*
- A1-41. *R-22*
- A1-42. *NA 19-70-46*
- A1-43. *600 lb*
- A1-44. *4000A engine removal trailer*
- A1-45. *To recharge aircraft nitrogen systems*
- A1-46. *One*

CHAPTER 2

- A2-1. *The appropriate technical manuals*
- A2-2. *Use hot rivets to join the two pieces*
- A2-3. *Driving and nondriving*
- A2-4. *They are encased in a housing*
- A2-5. *True*
- A2-6. *Shock absorbers*
- A2-7. *True*
- A2-8. *They contain hydraulic fluid*
- A2-9. *The tie rod*
- A2-10. *The connecting rod*
- A2-11. *The worm gear and sector*
- A2-12. *Improper adjustment of the steering linkage*
- A2-13. *Pinion tilt*
- A2-14. *The number of degrees the steering knuckle is tilted to the rear or front*
- A2-15. *The shoe will automatically lock when brakes are initially applied*
- A2-16. *A caliper*
- A2-17. *Bonding allows the pad to be worn thin without scarring the drum*

- A2-18. *40 percent*
- A2-19. *The pressure method*
- A2-20. *Transmission, propeller shaft, universal joints, differential, and axles.*
- A2-21. *The torque converter*
- A2-22. *A planetary gear system*
- A2-23. *The planet pinion gears*
- A2-24. *The hydraulic control units*
- A2-25. *On the output shaft*
- A2-26. *The throttle valve*
- A2-27. *The hydraulic control unit*
- A2-28. *It applies torque to the rear wheels only*
- A2-29. *The transfer case will produce unusual noises*
- A2-30. *True*
- A2-31. *It permits the change of direction of drive*
- A2-32. *To adjust for the difference in the distance the driven wheels travel when the vehicle turns*
- A2-33. *They allow for one wheel to turn faster than the other when the vehicle is turning*
- A2-34. *Causes it to lose power*
- A2-35. *Toothed clutches*
- A2-36. *Full-floating drive axles*
- A2-37. *It channels the gasses to the rear of the vehicle to prevent the driver from breathing harmful gasses*
- A2-38. *Open faced rims*
- A2-39. *They should be installed so that they are facing each other*
- A2-40. *The deflated tire flag*
- A2-41. *3/4 in*
- A2-42. *An inflation cage and a tire inflator assembly*
- A2-43. *10*
- A2-44. *Limited to 1 weld, no longer than 1 inch*

CHAPTER 3

- A3-1. *It increases*
- A3-2. *Humidity*
- A3-3. *Top dead center*
- A3-4. *Traveling in the downward direction*
- A3-5. *It allows the engine to run without varying in engine speed.*

- A3-6. *The type of fuel used*
- A3-7. *A gasoline engine uses spark plugs to ignite the fuel and a diesel engine heats the air in the cylinder by compressing it to ignite the fuel.*
- A3-8. *Power*
- A3-9. *Friction*
- A3-10. *The power and economy will increase.*
- A3-11. *The camshaft*
- A3-12. *The cylinder head*
- A3-13. *The connecting rod*
- A3-14. *The compression ring*
- A3-15. *A clicking noise can be heard while the engine is running.*
- A3-16. *The timing gears*

CHAPTER 4

- A4-1. *Volatility*
- A4-2. *Octane rating*
- A4-3. *Fuel tank, fuel pump, fuel filter, carburetor, and fuel lines*
- A4-4. *15 parts air to 1 part fuel*
- A4-5. *A gauge and a sending unit*
- A4-6. *It will hold the fuel float needle valve off its seat*
- A4-7. *3-5 psi*
- A4-8. *A non-positive diaphragm pump*
- A4-9. *It creates a vacuum at the outlet of the fuel nozzle.*
- A4-10. *The float circuit*
- A4-11. *The accelerator pump circuit*
- A4-12. *To reduce the amount of air entering the throat*
- A4-13. *Between the carburetor and the block*
- A4-14. *It is known as a compression-ignition engine.*
- A4-15. *Loss of torque*
- A4-16. *Cleanliness*
- A4-17. *Flow freely at low temperatures*
- A4-18. *Open combustion chamber and precombustion chamber*
- A4-19. *Higher injection pressure to obtain proper atomization*
- A4-20. *The throttle and injectors*
- A4-21. *To prevent the engine from overspeeding and allow the engine to meet changing load conditions.*
- A4-22. *The type of load and the degree of control desired*

- A4-23. *A variable-speed governor*
- A4-24. *A speed-limiting governor*
- A4-25. *Overspeed trips*
- A4-26. *A supply pump*
- A4-27. *Supply pumps*
- A4-28. *Atomization*
- A4-29. *It meters and times the fuel injection*
- A4-30. *By the push rod and rocker arm*
- A4-31. *Burning a small amount of the diesel fuel in the air prior to the air entering the cylinder*
- A4-32. *In the precombustion chamber*
- A4-33. *The intake manifold*
- A4-34. *There is air trapped in the fuel system*
- A4-35. *Remove the valve cover*
- A4-36. *Clogged fuel injector*

CHAPTER 5

- A5-1. *A blower*
- A5-2. *The fan*
- A5-3. *An automatic transmission*
- A5-4. *Two*
- A5-5. *A thermostat*
- A5-6. *A shutter*
- A5-7. *60% ethylene glycol and 40% water*
- A5-8. *One part ethylene glycol and two parts water*
- A5-9. *To help cool the engine*
- A5-10. *The oil pump*
- A5-11. *A rotary or gear pump*
- A5-12. *An oil temperature regulator*
- A5-13. *It eliminates excessive pressure in the crankcase*

CHAPTER 6

- A6-1. *A schematic diagram*
- A6-2. *It shows electrical wire routing between components and the approximate physical location of the components*
- A6-3. *The A/S32A-31A Towing Tractor*
- A6-4. *The wire is a neutral wire*
- A6-5. *An electrical grounding is not possible*

- A6-6. *A rubber mat*
- A6-7. *2.15 Vdc*
- A6-8. *1.265-1.290*
- A6-9. *A hydrometer*
- A6-10. *Hydrogen*
- A6-11. *By removing a small amount of electrolyte and replacing with distilled water*
- A6-12. *At 130% of its rated output*
- A6-13. *Six*
- A6-14. *A high resistance reading in one direction and a low resistance reading in the other direction*
- A6-15. *To prevent the battery from discharging through the generator when the engine is not running*
- A6-16. *A few turns of heavy wire*
- A6-17. *To protect the generator and charging circuit from overload*
- A6-18. *The regulator for the alternator does not require a reverse current relay*
- A6-19. *To control the rotor current*
- A6-20. *Perform a good visual inspection*
- A6-21. *Dirt and electrolyte on top of the battery*
- A6-22. *15,000-20,000 Vdc*
- A6-23. *To limit the current flow across the breaker points during low-speed operation*
- A6-24. *The breaker points*
- A6-25. *The capacitor*
- A6-26. *The distributor*
- A6-27. *Less battery voltage required for ignition*
- A6-28. *Primary-to-secondary coil test*
- A6-29. *To change electrical energy to mechanical energy*
- A6-30. *Gear reduction*
- A6-31. *The overrunning clutch*
- A6-32. *To shift the starter pinion into engagement with the ring gear*
- A6-33. *The neutral safety switch*
- A6-34. *Engine blower air pressure*
- A6-35. *1.220 or less*
- A6-36. *Gauges*
- A6-37. *Electrically*
- A6-38. *Bourdon tube and electrical*
- A6-39. *Switches*
- A6-40. *In series*

- A6-41. *GTC-85*
- A6-42. *A vibrator-type horn*
- A6-43. *Blackout lights*
- A6-44. *On the master cylinder mounting bracket*

CHAPTER 7

- A7-1. *Germanium and Silicone*
- A7-2. *A diode*
- A7-3. *A Zener diode*
- A7-4. *A transistor*
- A7-5. *A very small gate voltage can be used to control high power requirements*
- A7-6. *A dc signal voltage*
- A7-7. *The ease with which a substance conducts lines of force when compared with air*
- A7-8. *Increase the number of brushes*
- A7-9. *True*
- A7-10. *The ac generator has slip rings and the dc generator has a commutator*
- A7-11. *A self-excited generator*
- A7-12. *The field excitation*
- A7-13. *True*
- A7-14. *The exciter*
- A7-15. *208 Vac*
- A7-16. *DC undervoltage*
- A7-17. *It is a 28 Vdc, front axle, reversible, variable-speed motor*
- A7-18. *Two*
- A7-19. *115/200 Vac, 3-phase, 4-wire, 400 Hz*
- A7-20. *500 amps*
- A7-21. *S-29*
- A7-22. *A thermal time-delay relay*
- A7-23. *The circuit breakers*
- A7-24. *In the hanger bays of shore stations and aircraft carriers*
- A7-25. *220/440 Vac, 60 Hz*
- A7-26. *Replace the worn cable*
- A7-27. *NAVAIR 17-1-116*
- A7-28. *The DA-675/MSM*
- A7-29. *Both ac and dc sections of the load bank may be operated individually or simultaneously without influencing each other*

A7-30. *DC under voltage*

A7-31. *The worker should use only USDA approved tools*

CHAPTER 8

A8-1. *A liquid can be compressed to half of its original volume*

A8-2. *Pascal's law*

A8-3. *A reservoir*

A8-4. *Hand pump*

A8-5. *True*

A8-6. *GPM*

A8-7. *Rotary pumps*

A8-8. *Reciprocating pumps*

A8-9. *A Cellulose paper*

A8-10. *A 3-micron non-bypass filter*

A8-11. *A relief valve*

A8-12. *A rotary spool valve*

A8-13. *An accumulator can be used as a reservoir if the hydraulic system is over serviced*

A8-14. *A snubber*

A8-15. *NAVAIR 17-35MTL-1*

A8-16. *True*

A8-17. *A piston type*

A8-18. *A open-center system*

A8-19. *A closed-center system*

A8-20. *Worn seal*

A8-21. *Oxidation*

A8-22. *Lint free*

A8-23. *Under direct supervision of the cognizant engineering activity*

A8-24. *The power section and the actuating section*

A8-25. *A fixed displacement pump*

A8-26. *The cleanliness of the system*

A8-27. *Internal leakage*

CHAPTER 9

A9-1. *Gases are highly compressible*

A9-2. *It is considered an inert gas and is chemically inactive*

A9-3. *It is a by-product of oxygen production*

- A9-4. *A gray bottle with one black band*
- A9-5. *Class II*
- A9-6. *3,000 psi*
- A9-7. *Six*
- A9-8. *3,500 psi*
- A9-9. *The manifold bypass valve*
- A9-10. *The manifold bypass gauge*
- A9-11. *200 psi*
- A9-12. *3,500 psi*
- A9-13. *Relief valves*
- A9-14. *Defective piston*
- A9-15. *Five*
- A9-16. *They are black with two green stripes*

CHAPTER 10

- A10-1. *Combustion*
- A10-2. *Combustibles*
- A10-3. *-297 °F*
- A10-4. *862 to 1*
- A10-5. *It is a double wall tank with a powder-type material used as an insulator*
- A10-6. *50 gal*
- A10-7. *By gravity*
- A10-8. *False*
- A10-9. *An evaporation loss rate test*
- A10-10. *The bubble test*
- A10-11. *99.5%*
- A10-12. *Acetylene*
- A10-13. *Upon completion of preoperational inspections*
- A10-14. *A depot-level activity*
- A10-15. *Green with one white band*
- A10-16. *A nitrogen source*
- A10-17. *2,400 psi*
- A10-18. *25:1 to 36:1*
- A10-19. *Indirect regulator flow*
- A10-20. *90 to 150*
- A10-21. *MIL-C-52211, Class A*
- A10-22. *The Aviators' Breathing Oxygen (ABO) Surveillance Program*

CHAPTER 11

- A11-1. *British thermal units*
- A11-2. *Specific heat*
- A11-3. *Sensible heat*
- A11-4. *Latent heat*
- A11-5. *Super heat*
- A11-6. *Absorption*
- A11-7. *Boyles law*
- A11-8. *Charles' law*
- A11-9. *Condensation*
- A11-10. *The both have the capacity to absorb water*
- A11-11. *A liquid exchanger*
- A11-12. *It receives low pressure refrigerant vapor from the evaporator and compresses it to such an extent that it liquefies in the condenser*
- A11-13. *The receiver*
- A11-14. *The expansion valve*
- A11-15. *The thermobulb*
- A11-16. *A cool vapor at low pressure*
- A11-17. *The level of refrigerant is low*
- A11-18. *In the receiver*
- A11-19. *To protect the compressor from low inlet pressure and excessive discharge pressure*
- A11-20. *On the flightline of a naval air station*
- A11-21. *Humidify*
- A11-22. *Pump down*
- A11-23. *It is connected to the refrigerant supply cylinder when servicing the unit with refrigerant*
- A11-24. *It is virtually instantaneous*
- A11-25. *Cool Liquid*
- A11-26. *ST-1000*
- A11-27. *Loose drive coupling*

CHAPTER 12

- A12-1. *A centrifugal-flow*
- A12-2. *The intake section*
- A12-3. *The compressor section*
- A12-4. *The accessory section*

- A12-5. *The bypass valve*
- A12-6. *By bleeding control air pressure off the diaphragm and bypassing fuel away from the engine*
- A12-7. *A dual orifice*
- A12-8. *A drain check valve*
- A12-9. *By passing it through an oil cooler when the oil gets hot*
- A12-10. *By the accessory drive gear section of the engine*
- A12-11. *The 10% switch*
- A12-12. *When the engine is between 0% and 35% of rated speed*
- A12-13. *The 35% switch*
- A12-14. *Six*
- A12-15. *No. 5*
- A12-16. *A gear type*
- A12-17. *It can cause paralysis*
- A12-18. *The 110% centrifugal switch*
- A12-19. *Use a soft cloth and cleaning solvent*
- A12-20. *Use a de-carbonizing solvent*
- A12-21. *Shot-gunning*
- A12-22. *Excessive fuel in the combustion chamber*
- A12-23. *Defective 110% switch*
- A12-24. *The UPUA4-1 gas turbine engine analyzer*
- A12-25. *Personnel should be proficient in using a dummy load bank*
- A12-26. *5-amp fuse*
- A12-27. *Always wear the foam-type hearing protectors when working on or near the equipment*

CHAPTER 13

- A13-1. *The A/S32A-35A CVCC*
- A13-2. *440*
- A13-3. *70,000 lb*
- A13-4. *The ac generator*
- A13-5. *Annually, after repair or replacement of a major component, and prior to a deployment*
- A13-6. *6V-53TA*
- A13-7. *5 gallons*
- A13-8. *MV9*
- A13-9. *500 gpm*

- A13-10. 3 bottles*
- A13-11. 2 valves*
- A13-12. 2 1/2 inch*
- A13-13. Three per inch*
- A13-14. At a rework facility*
- A13-15. A diesel engine*
- A13-16. It will apply the brakes when the operator is not sitting on the seat*
- A13-17. The forks will rise*
- A13-18. 9 mph*
- A13-19. The area between the front and rear sections of the scrubber*
- A13-20. Operate, analyze, isolate, repair, and operate*
- A13-21. Perform an operational check*

Assignment Questions

Information: The text pages that you are to study are provided at the beginning of the assignment questions.

ASSIGNMENT 1

Textbook Assignment: "The Aviation Support Equipment (AS) Rating," chapter 1, pages 1-1 through 1-30, and "Chassis and Attaching Systems," chapter 2, pages 2-1 through 2-15.

- 1-1. Minimum occupational requirements for advancement are contained in what publication?
 1. NAVPERS 15060
 2. NAVPERS 18068
 3. BUPERS 13067
 4. BUPERS 13650
- 1-2. The Aviation Support Equipment Technician (AS) rating was first established in what year?
 1. 1950
 2. 1956
 3. 1966
 4. 1967
- 1-3. The first AS class "A" school convened September 9, 1967 at what location?
 1. NTTC Memphis
 2. NTTC North Island
 3. NTC Orlando
 4. NTC Great Lakes
- 1-4. The AS rating initially consisted of what total number of service ratings?
 1. One
 2. Two
 3. Three
 4. Four
- 1-5. The acronym "NEC" stands for what term?
 1. Navy Education Code
 2. Navy Employment Code
 3. Navy Enlistment Code
 4. Navy Enlisted Classification
- 1-6. The shore support equipment tow tractor technician has what NEC?
 1. 7602
 2. 7603
 3. 7607
 4. 7609
- 1-7. Afloat MEPP technicians should be assigned what NEC?
 1. 7604
 2. 7605
 3. 7613
 4. 7615
- 1-8. AS technicians are usually assigned to activities that perform intermediate level maintenance aboard which of the following locations?
 1. Naval air stations
 2. Aircraft carriers
 3. Overseas shore stations
 4. All of the above
- 1-9. Personnel in the AS rating are primarily concerned with what part(s) of support equipment?
 1. Operation
 2. Repair
 3. Inspections
 4. Both 2 and 3 above
- 1-10. Which of the following statements is NOT true when talking about support equipment maintenance?
 1. Equipment failure can delay a mission
 2. Periodic Maintenance is an important process to maintain equipment properly
 3. Maintenance on SE only needs to be performed if the unit is not operational
 4. Corrosion control is an important part of the maintenance process
- 1-11. What are the two types of maintenance performed on SE?
 1. Preventive and corrective
 2. Corrective and unscheduled
 3. Preventive and calendar
 4. Calendar and periodic

- 1-12. What official or activity establishes the minimum maintenance requirements necessary to maintain SE?
1. Naval Air Systems Command
 2. Naval Depot Operations Center
 3. Chief of Naval Operations (CNO)
 4. Naval Facilities Engineering Command
- 1-13. Records and forms for new SE are generated by what activity?
1. The SE controlling authority
 2. The designated rework point
 3. The supply department
 4. The receiving activity
- 1-14. An inventory of all equipment records should be conducted during which of the following inspections?
1. The preoperational
 2. The periodic
 3. The transfer
 4. The quarterly
- 1-15. Minimum requirements to maintain SE in satisfactory operational condition is contained in what publication?
1. The preoperational checklist
 2. The calendar checklist
 3. The depot maintenance checklist
 4. The maintenance requirements cards
- 1-16. Most of the corrective maintenance actions required are the result of which of the following factors?
1. Poor maintenance
 2. The normal wear
 3. Unqualified or careless operators
 4. Both 2 and 3 above
- 1-17. What is the first logical step when performing a corrective maintenance action?
1. Order repair parts
 2. Perform a power test
 3. Disassemble the components
 4. Perform a thorough inspection
- 1-18. Which of the following factors will not help the technician during the initial steps of a corrective maintenance action?
1. Preliminary checks
 2. Past troubleshooting experiences
 3. Removing and replacing parts
 4. A thorough knowledge of the equipment
- 1-19. Upon completion of a maintenance task, which of the following steps should you perform?
1. Replace inspection panels
 2. Inventory all tools
 3. Clean the work area and inspect of FOD on the equipment
 4. All of the above
- 1-20. What is the purpose of cleaning your work area immediately after completing a task?
1. Debris could be ingested into an engine
 2. Equipment could skid
 3. Personnel could fall
 4. All of the above
- 1-21. The correct procedures for removing and installing major components are contained in which of the following publications?
1. The maintenance requirements cards
 2. The equipment maintenance manual
 3. The illustrated parts breakdown
 4. The group assembly parts list
- 1-22. Problems caused by maintenance personnel are published monthly in which of the following publications?
1. Talking shop
 2. Approach magazine
 3. The NEASU tech report
 4. The Navy Times
- 1-23. What are the two elements in gasoline that allow it to burn freely and produce heat energy?
1. Hydrogen and nitrogen
 2. Carbon and hydrogen
 3. Carbon and oxygen
 4. Hydrogen and oxygen
- 1-24. What are the major properties of gasoline that affect engine performance?
1. Volatility, minimum foreign matter, good antiknock properties
 2. High carbon content, high flash point, low viscosity
 3. Volatility, viscosity, purity
 4. Purity, high carbon content, high flash point
- 1-25. To meet the requirements of the gas turbine compressor, what type of fuel must be used?
1. Low-grade gasoline
 2. High-octane gasoline
 3. Aviation Jet propulsion fuel
 4. Diesel fuel

- 1-26. What is the primary purpose of a lubricant?
1. To enhance metal-to-metal contact in an operation engine
 2. To increase friction
 3. To reduce engine heat
 4. To reduce friction
- 1-27. Lubricating oil that contains additives specifically designed to help clean the piston rings and other parts of the engine is known as what type of oil?
1. Heavy duty oil
 2. Detergent oil
 3. Multi-purpose oil
 4. Machine oil
- 1-28. For what reason should petroleum-base brake fluid NOT be mixed with synthetic brake fluid?
1. The chemical action cause heat
 2. Foam will occur that will add air to the brake system
 3. The heat expansion may damage the brake lines
 4. A jelly substance will form and damage will occur to the rubber seals
- 1-29. When testing a radiator, a hydrometer measures what property of the solution?
1. The boiling point
 2. The specific gravity
 3. The freezing temperature
 4. The percentage of antifreeze in the radiator
- 1-30. Support equipment is most often used in what type of atmosphere?
1. Hot, dry
 2. Hot, humid
 3. Cold, artic
 4. Salt-filled
- 1-31. During storage and shipment of SE, what is the most difficult problem to control?
1. Corrosion
 2. Physical damage
 3. Deterioration of non-metallic parts
 4. Pilferage
- 1-32. What is the conductor when dealing with electrochemical corrosion?
1. The anode
 2. The cathode
 3. The diode
 4. The electrolyte
- 1-33. Controlling corrosion by maintaining a dry environment through the use of moisture barriers and drying agents is known by what term?
1. Preservation
 2. Humidification
 3. Restoration
 4. Isolation
- 1-34. What manual should be used for support equipment cleaning and corrosion control?
1. NAVAIR 17-1-125
 2. NAVAIR 17-6-354
 3. NAVAIR 19-1-125
 4. OPNAVINST 4790.2
- 1-35. The NAVAIR 16-1-540 contains what type of information?
1. A list of corrosion control PQS
 2. A list of SE corrosion control publications
 3. Avionics corrosion control procedures
 4. Support equipment corrosion control procedures
- 1-36. What are two of the major categories of avionic and non-avionic SE?
1. General and experimental
 2. Common and peculiar
 3. Special and operational
 4. Experimental and operational
- 1-37. What military standard designates how a new model of SE is derived?
1. MIL-STD-378C
 2. MIL-STD-784B
 3. MIL-STD-875A
 4. MIL-STD-785-AA
- 1-38. What is the maximum amperage output of the NC-8A/1?
1. 500 amps intermittently
 2. 650 amps continuously
 3. 750 amps intermittently
 4. 800 amps continuously
- 1-39. What type of engine is used to drive the generator of the NC-10C mobile electric power plant?
1. An eight-cylinder Detroit diesel engine
 2. A six-cylinder Detroit diesel engine
 3. A four-cylinder Detroit diesel engine
 4. A six-cylinder gasoline engine

- 1-40. What type of an external power source is used to drive the MMG-1A?
1. 115 or 220 Vac
 2. 200 or 400 Vac
 3. 220 or 440 Vac
 4. 400 or 440 Vac
- 1-41. What is the maximum amperage output of the A/S37A-3 shipboard mobile electric power plant?
1. 28 amps
 2. 500 amps
 3. 750 amps
 4. 1000 amps
- 1-42. What items of SE is used to test the voltage, amperage, and frequency of a mobile electric power plant?
1. The DA-675/MSM
 2. The NC-10C MEPP
 3. The NC-8A MEPP
 4. The AS/USM-128
- 1-43. At a pressure of 5,000 psi, the A/M27T-5 has a rated output capacity of how many gallons per minute?
1. 15
 2. 20
 3. 25
 4. 30
- 1-44. What type of prime mover is used to power the A/M27T-7?
1. A hydraulic motor
 2. A diesel engine
 3. A gasoline engine
 4. An electric motor
- 1-45. What is the maximum hydraulic fluid capacity of the A/M27M-10?
1. 1 gallon
 2. 10 gallons
 3. 20 gallons
 4. 55 gallons
- 1-46. The HSU-1 has a maximum hydraulic fluid capacity of how many gallons?
1. 1
 2. 2
 3. 3
 4. 4
- 1-47. What type of towing tractor is used to tow heavy shore-based aircraft?
1. The A/S32A-31A
 2. The A/S32A-32
 3. The A/S32A-37
 4. The A/S32A-38
- 1-48. The A/S32A-31A is specially equipped to carry what type of equipment?
1. A hydraulic power supply
 2. A gas turbine compressor
 3. A generator set
 4. A nitrogen-servicing bottle
- 1-49. The A/S32A-30A can tow a maximum of how many pounds?
1. 10,000
 2. 20,000
 3. 30,000
 4. 40,000
- 1-50. Which of the following towing tractors is steered by a joy stick?
1. The A/S32A-32
 2. The A/S32A-31A
 3. The A/S32A-34
 4. The A/S32A-37
- 1-51. What type of refrigerant is contained in the A/M32C-17?
1. R-12
 2. R-22
 3. R-134
 4. R-137
- 1-52. What type of prime mover powers the compressor of the A/M32C-21?
1. An electric motor
 2. A diesel motor
 3. A gasoline engine
 4. A pneumatic motor
- 1-53. What components are used to change the height of a tripod jack?
1. A variable height platform
 2. Leg extensions
 3. Wheel kits
 4. Ram extensions

- 1-54. What type of maintenance platform has a height range of 3 to 7 feet?
1. The B-1 stand
 2. The B-2 stand
 3. The B-5 stand
 4. The B-4 stand
- 1-55. What maintenance platform has jack pads that can be used as brakes?
1. The B-1 stand
 2. The B-2 stand
 3. The B-5 stand
 4. The B-4 stand
- 1-56. What type of trailer is used for removing and installing aircraft engines?
1. The NET-4
 2. The 3000 trailer
 3. The 4000A trailer
 4. The 5500 trailer
- 1-57. What is the maximum nitrogen output pressure of the A/U26U-4 nitrogen-servicing cart?
1. 2,500 psi
 2. 3,000 psi
 3. 3,500 psi
 4. 4,000 psi
- 1-58. The storage tank on the TMU-70 can hold a maximum of how many gallons of LOX?
1. 20
 2. 25
 3. 45
 4. 50
- 1-59. What type of transfer system is incorporated on the TMU-70?
1. A closed-loop
 2. An open-loop
 3. A direct feed
 4. A high pressure
- 1-60. What parts are installed on a vehicles frame to provide additional strength at the point where the frame members are joined together?
1. Frame plates
 2. Cross members
 3. Gusset plates
 4. Side members
- 1-61. What is the preferred method of installing new members in a vehicle frame when replacement is required?
1. Nuts and bolts
 2. Oxyacetylene welding
 3. Hot rivets
 4. Arc welding
- 1-62. The axle in a vehicle that transmits power from the transmission to the driving wheels is know as what type of axle?
1. A live axle
 2. A power axle
 3. An inertial axle
 4. A dead axle
- 1-63. On a vehicle that uses coil springs in the suspension system, you can reduce pitching by taking which of the following actions?
1. By reducing friction between the springs and the frame
 2. By adding rubber bumpers
 3. By adding shock absorbers
 4. By removing the spacers between the springs and the frame
- 1-64. What component(s) are added between the springs and the frame to eliminate squeaking?
1. Rubber spacers
 2. A torque rod
 3. A stabilizer shaft
 4. Shock absorbers
- 1-65. Why are rubber mountings used for fastening shock absorbers to the frame and axle of a vehicle?
1. To prevent over-compression of the springs
 2. To prevent noise and wear
 3. To provide a controlled rebound of the springs
 4. To provide controlled flexing of the springs
- 1-66. In a steering system, what is the purpose of the tie rod?
1. To eliminate play in the steering system
 2. To reduce the vehicles turning radius
 3. To keep the front wheels in proper alignment
 4. To reduce vibration in the steering system

- 1-67. The ratio between the number of turns of the steering wheel and the number of degrees of movement of the pitman arm is the function of what component?
1. The worm gear only
 2. The sector gear only
 3. The worm and sector gear
 4. The cam roller
- 1-68. What is the major difference between the two types of power steering systems?
1. The type of actuating system used
 2. The location of the power cylinder and control valve
 3. The pressure required by the systems
 4. The manner in which the power steering pump is connected to the engine
- 1-69. Excessive play in a steering system is caused by which of the following conditions?
1. Low air pressure in the tires
 2. Loose wheel bearings
 3. Tight linkage adjustment
 4. Improperly adjusted brakes
- 1-70. Pivot inclination, caster, camber, toe-in, and toe-out refer to which of the following terms?
1. Front-end geometry
 2. Steering ratio
 3. Steering angle
 4. Turning radius
- 1-71. Pivot inclination is a term referring to what position of the kingpin?
1. The number of degrees it is tilted from vertical towards the rear of the vehicle
 2. The number of degrees it is tilted from vertical towards the center of the vehicle
 3. The number of degrees it is tilted from vertical towards the front of the vehicle
 4. The number of degrees it is tilted from vertical towards the side of the vehicle
- 1-72. Positive caster is achieved when the knuckle pivots are tilted in what direction?
1. To the back of the vehicle
 2. To the front of the vehicle
 3. To the left of the vehicle
 4. To the right of the vehicle
- 1-73. In a vehicle steering system, how is camber obtained?
1. By inserting wedges and shims between the front axle and the spring
 2. By tilting the spindles slightly downward on the steering knuckle
 3. By inserting shims between the upper suspension arm and the frame
 4. By tilting the spindles slightly upward on the steering knuckle
- 1-74. You should check which of the following items to ensure proper operation when you are servicing a vehicle with power steering?
1. The drive belt
 2. The hoses and fittings
 3. The fluid level
 4. All of the above
- 1-75. To correct toe-in of a vehicle, you must adjust what component(s)?
1. The drag link
 2. The tie rods
 3. The pitman arm
 4. The steering arm knuckle

ASSIGNMENT 2

Textbook Assignment: "Chassis and Attaching Systems," chapter 2, pages 2-15 though 2-78.

- 2-1. The braking system on a power support vehicle performs what function?
1. Decelerates the moving vehicle
 2. Stops the vehicle in as short a distance as possible
 3. Holds the vehicle in a stopped position
 4. All of the above
- 2-2. Braking action in a hydraulic braking system is accomplished by what method?
1. Rods and cables
 2. A fluid coupling
 3. Air pressure
 4. Electrical energy
- 2-3. Individual brakes of the internal expanding type are most often used for what purpose?
1. Trailer brakes
 2. Parking brakes
 3. Vehicle wheel brakes
 4. Brakes for controlling the speed of auxiliary equipment drive shafts
- 2-4. Which of the following statements best describes the self-energizing action of the internal-expanding braking system?
1. When the drum is rotating counterclockwise, the shoes will rotate with the drum
 2. When the drum is rotating clockwise, the shoes remain stationary
 3. When the drum is rotating counterclockwise, the shoes will rotate clockwise
 4. When the drum is rotating clockwise, the shoes will rotate counterclockwise
- 2-5. A self-energizing brake shoe automatically locks when pressure is applied to the brake pedal if the anchor pin is located in what position?
1. If the pin is located too far to the rear on the brake drum
 2. If the pin is located too far forward on the brake drum
 3. If the pin is located too close to the center of the brake drum
 4. If the pin has frozen in position
- 2-6. On a disc brake assembly, the disc is bolted to what component?
1. The axle housing
 2. The spindle
 3. The wheel hub
 4. The knuckle hub
- 2-7. What component in a disc brake system directly applies pressure to the brake pads?
1. The wheel cylinder
 2. The master cylinder
 3. The caliper
 4. The cam
- 2-8. Disc brake runout or wobble should be checked by using which of the following instruments?
1. A wobble plate
 2. A dial indicator
 3. A depth gauge
 4. A dynameter
- 2-9. Servicing a disc brake caliper usually involves replacing which of the following parts?
1. The piston
 2. The seals
 3. The dust boot
 4. All of the above
- 2-10. The assembly around which the expander tube brake assembly is built is known by what name?
1. The spider
 2. The boss
 3. The housing
 4. The nest
- 2-11. In addition to having high friction qualities, the material used for brake linings must have which of the following characteristics?
1. Be durable and moisture resistant
 2. Be able to withstand high temperatures
 3. Be corrosion resistant
 4. Be able to withstand extremely cold temperatures

- 2-12. What advantage is gained by combining a steel drum and a cast iron liner when making a brake drum?
1. The cast iron drum won't rust
 2. The steel drum dissipated heat rapidly
 3. The cast iron liner dissipates heat rapidly
 4. The steel drum will resist warping
- 2-13. Which of the following actions must occur to allow a self-adjusting brake mechanism to function?
1. The primary shoe must move away from the anchor pin
 2. The adjusting mechanism must pivot on the secondary shoe
 3. The secondary shoe must be forced against the anchor pin by the primary shoe
 4. The adjusting mechanism must pivot on the primary shoe
- 2-14. A road test in which the brakes must stop the vehicle within a reasonable distance is conducted to check what condition?
1. To ensure the auto-adjust feature is working correctly
 2. To ensure the brakes are functioning correctly
 3. To check the brake pedal for play
 4. To check the emergency brake when vehicle is moving
- 2-15. What two types of braking systems are most often used on support equipment?
1. Hydraulic and mechanical
 2. Hydraulic and pneumatic
 3. Pneumatic and electrical
 4. Pneumatic and mechanical
- 2-16. When the brake lever is pulled in a mechanical braking system, the intermediate lever and spreader will perform what function?
1. Release the brake shoes from the drum
 2. Equalized the tension of the cables on the brakes
 3. Remove the slack from the from cable conduit
 4. Move the cable and apply the brake shoes to the drum
- 2-17. Mechanical braking systems must be inspected periodically for which of the following conditions?
1. Rust and corrosion
 2. Frayed cables and bent rods
 3. Loose clams and fittings
 4. All of the above
- 2-18. The master cylinder performs all but which of the following functions?
1. As a control valve
 2. As an actuator
 3. As a pump
 4. As a fluid reservoir
- 2-19. What is the function of the compensating port in a master cylinder?
1. It permits fluid in the cylinder to flow to the reservoir during the release stroke
 2. It permits fluid to flow to and from the reservoir to allow for thermal expansion and contraction
 3. It furnishes fluid to the cylinder for the braking stroke
 4. Both 2 and 3 above
- 2-20. A single and double-piston wheel cylinder moves the brake shoes by changing hydraulic pressure to what type of force?
1. Pneumatic
 2. Mechanical
 3. Hydrostatic
 4. Vertical
- 2-21. Which of the following part(s) of the wheel cylinder should be removed when checking for leakage between the piston and cylinder wall?
1. The rubber seals
 2. The return spring
 3. The boots
 4. The primary cup
- 2-22. When servicing a braking system, what action should you perform?
1. Remove all dirt from the filler cap and filler opening
 2. Leave the proper space between the fluid level and the filler opening
 3. Use only the recommend fluid type
 4. All of the above

- 2-23. After you have installed a repaired master cylinder, what function should you perform first?
1. Bleed the system
 2. Operationally test the cylinder
 3. Adjust the brakes
 4. Visually check the master cylinder for leaks
- 2-24. What is the purpose of bleeding the hydraulic brake lines?
1. To remove excess hydraulic fluid
 2. To test for leaks
 3. To equalized hydraulic pressure in the lines
 4. To remove air from the system
- 2-25. When bleeding a hydraulic brake system, what wheel cylinder should you bleed first?
1. The right front
 2. The cylinder with the shortest line
 3. The cylinder with the longest line
 4. The left rear
- 2-26. In the high-pressure hydraulic brake system used on the A/S32A-37 (TA-35) aircraft towing tractor, the brake pedal is referred to by what name?
1. Pump
 2. Actuator
 3. Ram
 4. Accumulator
- 2-27. In a vacuum braking system, the hydrovac power brake cylinder is connected hydraulically to what component(s)?
1. The actuating slave cylinder
 2. The control valve
 3. The tandem piston vacuum power cylinder
 4. The master cylinder and the wheel cylinders
- 2-28. In the hydrovac braking system, when the brake pedal is depressed, pressure on the fluid in the master cylinder causes the diaphragm to move, therefore seating the vacuum valve and causing what other resulting action?
1. The bypass valve to open
 2. The vacuum valve to open
 3. The atmospheric valve to open
 4. The atmospheric pressure to replace the vacuum on the front side of each cylinder
- 2-29. The air control valve of the air-over-hydraulic braking system regulates the flow of compressed air to what component?
1. The air reservoir
 2. The system governor
 3. The air chamber in the pneumatic system
 4. The air chamber in the master cylinder
- 2-30. In which of the following ways does the automatic transmission differ from the standard transmission?
1. It automatically shifts from one forward speed /torque ratio to another
 2. It allows the driver to select forward/neutral/reverse without using a clutch
 3. Both 1 and 2 above
 4. It requires the use of a clutch to select the reverse speed/torque ratios
- 2-31. The driving member in a fluid coupling is known by what name?
1. The turbine
 2. The runner
 3. The pump
 4. The impeller
- 2-32. What is/are the advantage(s) of a fluid coupling?
1. It prevents sudden jerks of the engine from being transmitted to the gear s
 2. It prevents engine vibration from being transmitted to the rest of the power train
 3. It prevents engine overload
 4. All of the above
- 2-33. The bounce back effect in a torque converter is at a maximum when what condition in the fluid coupling exists?
1. The turbine is rotating much faster than the pump
 2. The pump is rotating faster than the turbine
 3. The pump and turbine are rotating at the same speed
 4. The pump and turbine are operating at zero vortex

- 2-34. How does the stator prevent the turbines flow of oil from opposing the pumps flow of oil?
1. By absorbing all the energy of the oil leaving the turbine
 2. By offering a flat surface to absorb the “bounce back” effect of the oil
 3. By redirecting the flow from the turbine to aid the pump
 4. By using a minimum amount to kinetic energy of the oil to prevent “bounce back”
- 2-35. During heavy load and hard-acceleration, the hindering action of the secondary pump in the torque converter is avoided by what means?
1. The secondary pump disengages and stops rotating
 2. The primary stator redirects the oil to bypass the secondary pump
 3. The secondary pump spins slower than the primary pump
 4. The secondary pump spins faster than the primary pump
- 2-36. When a torque converter reaches the coupling stage, which of the following conditions exists?
1. Both the primary and secondary stators are freewheeling
 2. Both the primary and secondary stators are operating
 3. Only the primary stator and primary pump are operating
 4. Only the secondary stator and secondary pump are operating
- 2-37. When a torque converter is used with an automatic transmission, what component of the converters hydraulic (oil) system is NOT required?
1. The cooler
 2. The filter
 3. The reservoir
 4. The supply pump
- 2-38. In the roller-type overrunning clutch, overrunning is permitted during which of the following conditions?
1. When the rollers wedge against the smaller spacings in the cam due to light spring action
 2. When the rollers move into the light springs and onto the larger spacings in the cam
 3. When the rollers wedge against the outer race due to slowing in the inner race
 4. When the rollers move against heavy springs into the smaller spacings in the cam
- 2-39. What component(s) is/are the heart of the modern type automatic transmission?
1. The fluid coupling
 2. The torque converter
 3. The planetary gears
 4. The hydraulic pumps
- 2-40. Which of the following actions occurs if a small gear drives a larger gear?
1. The speed increases and the torque decreases
 2. The speed decreases and the torque increases
 3. The speed and torque increase
 4. The speed and torque decrease
- 2-41. What type of gear has a tooth arrangement at right angles to the side of the gear?
1. Ring
 2. Spur
 3. Conical
 4. Helical
- 2-42. In a planetary gear system, which of the following is a characteristic of a planet pinion?
1. It has internal teeth
 2. It occupies the center position of the unit
 3. It rotates around the central components on the unit
 4. It has two smooth surfaces around which gears revolve
- 2-43. Locking any two gears together in a planetary gear system produces what result?
1. A direct drive condition
 2. A reverse drive condition
 3. A neutral or locked condition
 4. An increased speed condition

- 2-44. Which of the following is an advantage of the planetary gear system in a transmission?
1. There is little gear tooth contact; therefore, there is little friction in the system
 2. There is little damage to the gears because they are seldom meshed
 3. There is no need for special skills on the part of the driver for operation of the gear system because it is automatic
 4. There is rarely any contact between more than two gears in the system
- 2-45. The servo unit in an automatic transmission converts hydraulic pressure applied to the piston into mechanical force that actuates the friction bands for what purpose?
1. To hold a member of the planetary gear system to provide a specific gear ratio
 2. To hold two members of the planetary gear system to provide a specific gear ratio
 3. To enable the clutch disks to rotate as a unit
 4. To hold all three members of the planetary gear system to provide a direct connection
- 2-46. What component in an automatic transmission selects the gear ratio appropriate for the engine's load?
1. The torque converter
 2. The hydraulic operating unit
 3. The range selector
 4. The hydraulic control unit
- 2-47. What component in an automatic transmission maintains controlled oil pressure to the control units?
1. The regulator valve
 2. The manual valve
 3. The throttle valve
 4. The shift valve
- 2-48. The transmission is made fully automatic by what component or system?
1. The torque converter
 2. The range system
 3. The hydraulic control system
 4. The hydraulic operating units
- 2-49. Regulated oil pressure of 80 to 90 psi is NOT obtained until the oil reaches what location inside the transmission?
1. The primary reaction area of the regulator valve
 2. The secondary reaction area of the regulator valve
 3. The primary reaction area of the manual valve
 4. The secondary reaction area of the manual valve
- 2-50. The governor is normally mounted on what component?
1. The transmission output shaft
 2. The transmission input shaft
 3. The crankshaft
 4. The flywheel
- 2-51. The shift valve causes the vehicle transmission to up-shift when what condition exists?
1. When the throttle pressure exceeds the governor pressure
 2. When the governor pressure exceeds the throttle pressure
 3. When the governor and throttle pressure are equal
 4. When the vehicle begins moving in the forward direction
- 2-52. What component prevents the transmission from always shifting at the same vehicle speed?
1. The kickdown valve
 2. The throttle valve
 3. The regulator valve
 4. The shift valve
- 2-53. The shift valve in the automatic transmission is held in the servo position by the regulated oil pressure from what component?
1. The throttle valve
 2. The governor valve
 3. The kickdown valve
 4. The manual valve
- 2-54. When a vehicle is operating at full throttle with the transmission in direct drive, downshifting can occur by activating which of the following valves?
1. The throttle valve
 2. The governor valve
 3. The regulator valve
 4. The kickdown valve

- 2-55. The kickdown valve normally unseats when which of the following conditions exists?
1. When the vehicles speed decreases to a certain point
 2. When the full-shift oil pressure decreases
 3. When the vehicle reaches a point just beyond full throttle
 4. When it is at full-governor oil pressure
- 2-56. When the transmission is in the operating range, what valve prevents oil from the front pump from activating the shift valve?
1. The torque converter valve
 2. The manual selector valve
 3. The regulator valve
 4. The kickdown valve
- 2-57. Refer to figure 2-74 of your textbook. The governor oil pressure is prevented from operating the shift valve because of what other factor in the transmission?
1. The main-line oil pressures in the kickdown chamber
 2. The kickdown servo pressure
 3. The regulator valve pressure
 4. The shift valve oil pressure
- 2-58. Refer to figure 2-75 of your textbook. The clutch is prevented from engaging before the servo is fully released by what action?
1. The shift valve uncovers the clutch oil passage
 2. The accelerator goes through detent
 3. Governor oil pressure takes time to build up and actuate the clutch
 4. Release oil pressure is applied to the servo
- 2-59. When the accelerator is moved to less than full throttle after kickdown has occurred, the shift valve up-shifts because of what pressure?
1. Governor oil
 2. Kickdown valve
 3. Servo oil
 4. Manual selector valve oil
- 2-60. What component assists brakes in slowing heavy-duty vehicles?
1. The lockup clutch
 2. The blocker valve
 3. The hydraulic retarder
 4. The shuttle valve
- 2-61. What component prevents shifting to reverse while the vehicle is moving forward?
1. The lockup clutch
 2. The blocker valve
 3. The hydraulic retarder
 4. The shuttle valve
- 2-62. To determine the detailed step-by-step procedures for repairing a transmission, which of the following publications should you consult?
1. Maintenance requirements cards
 2. The transmission manufacturer's repair manual
 3. The maintenance manual for the equipment in which the transmission is used
 4. The operator's manual of the specific equipment
- 2-63. Which of the following items should NOT be adjusted until after the engine has been properly adjusted?
1. The control linkage
 2. The throttle linkage
 3. The bands
 4. The vacuum modulator
- 2-64. When troubleshooting an automatic transmission, what is the first step you should take?
1. Check the oil level
 2. Check the oil pressure to the various hydraulic circuits
 3. Check the control and throttle linkages
 4. Check the servo and band adjustments
- 2-65. When checking the oil level, most manufacturers recommend that you operate the engine and transmission until they have reached the normal operating temperature, operate the transmission through its ranges, and then check the oil level with the transmission in what range?
1. Direct drive
 2. Low
 3. Neutral
 4. Reverse
- 2-66. When a torque converter is a sealed unit, maintenance other than for oil leaks requires what action?
1. Complete overhaul of the unit
 2. The use of a parts kit to repair the unit
 3. Replacement of the unit
 4. Only limited repairs and replacement of worn parts

- 2-67. Testing the front and rear clutches of an automatic transmission requires the use of clean, moisture-free, compressed-air at what pressure?
1. 20 to 40 psi
 2. 30 to 100 psi
 3. 100 to 130 psi
 4. 130 to 200 psi
- 2-68. A defective clutch disc in an automatic transmission usually requires what type of maintenance?
1. Removal and overhauling of the clutch facings
 2. Replacement of the clutch discs with a parts kit
 3. Careful checking to determine the cause of the defect
 4. Replacement of the entire clutch assembly
- 2-69. Before reassembly of a hydraulic control, how should you clean the parts?
1. Use the proper solvent, and wipe dry with fibrous wipe material
 2. Use a highly volatile solvent, and dry by exposure to the air
 3. Use the proper solvent, and dry with clean, moisture-free, low-pressure compressed air
 4. Use a highly volatile solvent, and wipe dry with fibrous wipe material
- 2-70. When a four-wheel drive automotive vehicle needs additional traction, the required front-wheel drive is automatically provided by what device?
1. A power takeoff
 2. A sprag unit
 3. An auxiliary transmission
 4. A two-way clutch
- 2-71. For what reason is a slip joint in the propeller shaft of a vehicle power train vehicle necessary?
1. Because the distance between the engine and the transmission varies
 2. Because the distance between the transmission and the differential varies
 3. Because the differential moves up and down
 4. Because the differential moves forward and aft
- 2-72. What is the purpose of an automotive vehicle's differential assembly?
1. To connect the rear axles together to act as a single axle
 2. To permit both drive axles to be driven as a single unit even when they are driven at different speeds
 3. To prevent the rear axles from turning at different speeds
 4. To boost engine power transmitted to the wheels
- 2-73. In a left turn, the no-spin differential applies full drive to what wheel?
1. The left rear wheel
 2. The right rear wheel
 3. The left front wheel
 4. The right front wheel
- 2-74. Torque from the differential is delivered to the wheels by what component?
1. The pinion
 2. The ring gear
 3. The drive axle
 4. The transfer case
- 2-75. The exhaust system attaches to which of the following engine components?
1. The cylinder head
 2. The intake manifold
 3. The crankcase
 4. The air inlet housing

ASSIGNMENT 3

Textbook Assignment: "Chassis and Attaching Systems," chapter 2, pages 2-79 through 2-87, and "Principles of Internal Combustion Engines," chapter 3, pages 3-1 through 3-38.

- 3-1. Which of the following types of rims are most commonly used on support equipment?
1. Solid, split, and aircraft
 2. Split, aircraft, and demountable flange
 3. Split, solid, and automotive
 4. Split, solid, and demountable flange
- 3-2. What type of tire has cords that cross the tire at angles of 30 to 40 degrees?
1. Bias belted
 2. Bias ply
 3. Radial
 4. Solid rubber
- 3-3. What type of rim presents the greatest hazard to personnel?
1. A demountable flange rim
 2. An automotive rim
 3. A split rim
 4. A solid rim
- 3-4. The "deflated tire flag" should be used to show which of the following conditions?
1. The tire must be deflated
 2. The tire has been deflated only
 3. The valve core has been removed only
 4. The tire has been deflated and the valve core has been removed
- 3-5. Support equipment wheels removed to simplify other maintenance should be deflated to which of the following pressures?
1. 50 psi
 2. 30 psi
 3. 25 psi
 4. 15 psi
- 3-6. When installing a demountable flange onto the rim base, the opening between the flange ends should be within what range of measurement?
1. 1/4 in. to 1/2 in.
 2. 1/4 in. to 3/8 in.
 3. 3/8 in. to 1/2 in.
 4. 3/32 in. to 5/16 in.
- 3-7. When a tire/wheel assembly explodes violently during initial inflation, which of the following factors is/are normally the cause(s)?
1. Overinflation
 2. Material defects only
 3. Improper assembly only
 4. Material defects and improper assembly
- 3-8. To center the tube in a tire/wheel assembly after buildup, you should inflate the tire to what maximum pressure?
1. 10 psi
 2. 15 psi
 3. 20 psi
 4. 25 psi
- 3-9. When the bead of a tire fails to seat during inflation, you should apply what substance to the tire bead?
1. Talcum powder
 2. Tire lubricant
 3. General-purpose oil
 4. Dry-cleaning solvent
- 3-10. When mounting dual wheel assemblies on a vehicle, the demountable flanges should be facing what direction?
1. Both flanges should face inboard
 2. Both flanges should face outboard
 3. The flange on the inner wheel should face outboard; the flange on the outer wheel should face inboard
 4. The flange on the inner wheel should face inboard; the flange on the outer wheel should face outboard
- 3-11. An internal-combustion engine is a machine that performs what action?
1. It converts heat to create electrical energy
 2. It converts heat energy to mechanical energy
 3. It converts mechanical energy to heat energy
 4. It converts mechanical energy to electrical energy

- 3-12. Reciprocating motion in an internal-combustion engine is changed to rotary motion by what means?
1. The piston pin and a connecting rod
 2. The flywheel and a crankshaft
 3. The cylinder and a piston
 4. The crankshaft and a connecting rod
- 3-13. Which of the following basic parts are included in the 1-cylinder engine?
1. Cylinder, camshaft valve, piston, piston pin, connecting rod, and crankshaft
 2. Cylinder, valve, piston, piston pin, connecting rod, and crankshaft
 3. Cylinder, piston, piston pin, connecting rod, and crankshaft
 4. Cylinder, piston, connecting rod, and crankshaft
- 3-14. In a 4-stroke-cycle engine, which of the following events occurs during the second stroke?
1. The piston moves downward
 2. The waste gases are exhausted
 3. The air-fuel mixture is compressed
 4. The air-fuel mixture is ignited
- 3-15. At what point in the cycle of a 4-stroke-cycle engine does ignition occur?
1. Beginning of the compression stroke
 2. End of the compression stroke
 3. Beginning of the intake stroke
 4. During the power stroke
- 3-16. During the compression stroke, the piston is moving in (a) what direction and the valves are in (b) what position?
1. (a) Moving up (b) the exhaust valve is open and the intake valve is closed
 2. (a) Moving up (b) the exhaust and intake valves are closed
 3. (a) Moving down (b) the intake valve is open and the exhaust valve is closed
 4. (a) Moving down (b) the exhaust and intake valves are closed
- 3-17. During the power stroke, the piston is moving in (a) what direction and the valves are in (b) what position?
1. (a) Moving up (b) the exhaust valve is open; and the intake valve is closed
 2. (a) Moving up (b) the exhaust and intake valves are closed
 3. (a) Moving down (b) the intake valve is open; and the exhaust valve is closed
 4. (a) Moving down (b) and the exhaust and intake valves are closed
- 3-18. During the exhaust stroke, the piston is moving in (a) what direction and the valves are in (b) what position?
1. (a) Moving up (b) the exhaust valve is open; and the intake valve is closed
 2. (a) Moving up (b) the exhaust and intake valves are closed
 3. (a) Moving down (b) the intake valve is open; and the exhaust valve is closed
 4. (a) Moving down (b) the exhaust and intake valves are closed
- 3-19. The piston in a 4-stroke-cycle engine makes four strokes during what evolution?
1. A crankshaft revolution
 2. An engine cycle
 3. A two combustion cycles
 4. A cycle of two events
- 3-20. Which of the following statements is TRUE concerning the operating cycle of a 2-stroke-cycle diesel?
1. The exhaust valves and intake ports are never open at the same time
 2. The exhaust valves remain open until the piston reaches top dead center
 3. The inlet ports are uncovered after the exhaust valves open
 4. The inlet ports are uncovered when the piston reaches bottom dead center

- 3-21. Which of the following reasons partially accounts for the failure of a 2-stroke-cycle engine to produce twice the power of a 4-stroke-cycle engine of the same size?
1. Some power developed by the 2-stroke-cycle engine is used to force air and fuel into each cylinder
 2. Less than all the combustion gases are scavenged from each cylinder of the 2-stroke-cycle engine
 3. For a given air-fuel mixture, less fuel and air enter the cylinders of the 2-stroke-cycle engine
 4. Each of the above
- 3-22. The flywheel of an engine affects the operation of the engine by what means?
1. By smoothing out the power impulses
 2. By keeping the engine from stalling
 3. By preventing crankshaft vibration
 4. By increasing piston life
- 3-23. Engines are most commonly classified in which of the following ways?
1. By their valve arrangements
 2. By the number of their cylinders
 3. By the kind of fuel they burn
 4. By their cooling system
- 3-24. When the firing order is not marked on an engine and a manufacturer's manual is not available, what method should you use to find the engine's firing order?
1. Crank the engine by hand, observing the order in which the exhaust valves open
 2. Crank the engine by hand while observing the timing mark on the crankshaft
 3. Crank the engine with the starter and observe the rotor in the distributor
 4. Crank the engine by hand and observe the order in which the intake valves open
- 3-25. What type of internal-combustion engine has intake valves in the head and exhaust valves in the block?
1. F-head
 2. L-head
 3. I-head
 4. T-head
- 3-26. What type of internal-combustion engine has intake and exhaust valves in the head?
1. F-head
 2. L-head
 3. I-head
 4. T-head
- 3-27. What are the definitions of torque, energy, and power, in that order?
1. Turning force; capacity to do work; rate of doing work
 2. Turning force; rate of doing work; capacity to do work
 3. Rate of doing work; turning force; capacity to do work
 4. Rate of doing work; capacity to do work; turning force
- 3-28. Inertia will cause an object to resist which of the following changes?
1. Change of mechanical efficiency
 2. Change of speed only
 3. Change of direction only
 4. Change of speed and direction
- 3-29. The relationship between the power output of an engine and the energy in the fuel burned to produce this output is known by what term?
1. The mechanical efficiency
 2. The thermal efficiency
 3. The volumetric efficiency
 4. The area efficiency
- 3-30. The relationship between the amount of fuel-air mixture that enters an engine cylinder and the amount that could enter is known as by what term?
1. The mechanical efficiency
 2. The thermal efficiency
 3. The volumetric efficiency
 4. The area efficiency
- 3-31. What is the meaning of the cylinder designation 3 1/4 by 3 1/2 inches?
1. Piston stroke is 3 1/4 inches; cylinder bore is 3 1/2 inches
 2. Cylinder diameter is 3 1/4 inches; TDC-to-BDC distance in the cylinder is 3 1/2 inches
 3. Cylinder bore is 3 1/4 inches; piston head diameter is 3 1/2 inches
 4. Piston stroke is 3 1/4 inches; piston head diameter is 3 1/2 inches

- 3-32. The compression ratio of an engine is determined by what equation?
1. By subtracting the cylinder volume at TDC from the cylinder volume at BDC
 2. By dividing the cylinder volume at TDC by the cylinder volume at BDC
 3. By multiplying the cylinder volume at TDC by the length of the piston stroke
 4. By dividing the cylinder volume at BDC by the cylinder volume at TDC
- 3-33. Increasing the compression ratio of an engine will cause which of the following problems?
1. Excessive fuel consumption
 2. Knocking or rapping noise
 3. Excessive exhaust smoke
 4. Warped valves
- 3-34. Ignition timing should be adjusted so that the spark occurs when the piston does which of the following strokes?
1. Completes the intake stroke
 2. Starts down on the power stroke
 3. Completes the compression stroke
 4. Nears the end of the compression stroke
- 3-35. Gasoline and diesel engines are alike in what respect?
1. Both belong to the same engine family
 2. Both have the same basic internal components
 3. Both have the same number of cylinders
 4. Their internal parts are interchangeable
- 3-36. Which of the following parts provides a basic frame for the water-cooled engines used in automotive equipment?
1. The engine base
 2. The cylinder head
 3. The cylinder block
 4. The crankcase
- 3-37. What is the purpose of the interconnecting passages in the cylinder head and block?
1. To allow access for removal of the casting material
 2. To provide a path for the coolant to circulate
 3. To prevent cracks in the castings as they cool
 4. To reduce the weight of the engine
- 3-38. The purpose of fins surrounding the cylinders of an air-cooled engine is used to provide what specific function?
1. They are a means for strengthening the cylinder walls
 2. They are used as a mounting surface for the cylinder head
 3. They are a large surface area for heat dissipation
 4. They are a mounting surface for heat shields
- 3-39. Cylinder liners in an engine are used for what purpose?
1. To prevent scoring or cracking of the cylinder walls
 2. To increase cylinder wear limitations
 3. To eliminate cylinder block replacement due to cylinder wear
 4. To reduce the frequency of engine overhauls
- 3-40. Running an engine with the air cleaner removed would likely cause what problem?
1. Excessive gas consumption
 2. Excessive cylinder wear
 3. Excessive knocking
 4. Excessive bearing wear
- 3-41. One reason that engine cylinder heads are made of aluminum alloy is the ability to perform what function?
1. To resist wear
 2. To resist corrosion
 3. To retain its shape
 4. To conduct heat
- 3-42. The curved surfaces of the pockets in which the valves of an L-head type cylinder head operate are designed to perform what function?
1. To shorten the compression stroke
 2. To lengthen the compression stroke
 3. To decrease the turbulence of the fuel-air mixture
 4. To increase the turbulence of the fuel-air mixture
- 3-43. The stationary part of an internal-combustion engine that carries waste products of combustion from the cylinders is known by what name?
1. An intake manifold
 2. An exhaust manifold
 3. A carburetor
 4. A water pump

- 3-44. Why is it desirable that the intake manifold of a gasoline combustion engine be constructed to provide the fuel with a short and direct path between the carburetor and the cylinders?
1. To make the fuel-air mixture as uniform as possible
 2. To save space in the engine compartment
 3. To reduce the possibility of the fuel condensing in the manifold
 4. To keep the manifold from overheating
- 3-45. Which of the following features is common to all engines equipped with an exhaust gas recirculation system?
1. They have an intake manifold with exhaust passages
 2. Each cylinder contains two intake valves
 3. Each cylinder contains an exhaust valve and an exhaust port
 4. The exhaust valves are open during the intake strokes
- 3-46. A gasket is placed between the cylinder head and engine block for what reason?
1. To prevent gas and water leaks
 2. To provide even heat distribution
 3. To maintain clearance between the cylinder head and the engine block
 4. To prevent excessive temperatures within the cylinder head
- 3-47. In today's engines, fluid losses through clearances between moving parts and stationary parts are prevented by what means?
1. Neoprene seals and O-rings
 2. Leather seals
 3. Packing glands
 4. Plastic strips
- 3-48. The design of which of the following engine parts enables them to create an effect inside the combustion chambers that results in an improved fuel-air mixture?
1. Cylinder walls
 2. Pistons
 3. Exhaust valves
 4. Connecting rods
- 3-49. What principal difference exists between a diesel engine piston and a gasoline engine piston?
1. Diesel engine pistons weigh less than gasoline engine pistons
 2. Diesel engine pistons are made of cast iron, while gasoline engine pistons are made of aluminum
 3. Diesel engine pistons are usually fitted with more piston rings than gasoline engine pistons
 4. Diesel engine pistons have higher domes than gasoline engine pistons
- 3-50. The piston pin (wrist pin) is attached to the piston by what means?
1. A crankshaft
 2. A camshaft
 3. A connecting rod
 4. A balance shaft
- 3-51. In addition to sealing off the combustion chamber and distributing lubricating oil, piston rings serve what purpose?
1. To absorb the shock of the power stroke
 2. To prevent heat expansion of the piston
 3. To transfer heat from the pistons to the cylinder walls
 4. To provide an air bleed during the intake stroke
- 3-52. During engine operation, thrust from the piston is transmitted to the crankshaft by what component?
1. The balance shaft
 2. The camshaft
 3. The connecting rod
 4. The flywheel
- 3-53. Which of the following types of bearings is placed in the piston end of the connecting rod?
1. Roller
 2. Ball
 3. Bushing
 4. Annular
- 3-54. What is the function of the counterweights on a crankshaft?
1. To reduce shock from the power strokes
 2. To balance the weight of the connecting rod bearing assembly
 3. To transmit power from the crankshaft to the camshaft
 4. To provide momentum for crankshaft rotation during the compression strokes

- 3-55. What part(s) of an engine is likely to fail when subjected to uncontrolled torsional vibrations?
1. The camshaft
 2. The pistons
 3. The connecting rods
 4. The crankshaft
- 3-56. The purpose of thrust faces found on some main bearings is used to perform what function?
1. To prevent crankshaft vibration
 2. To eliminate crankshaft end play
 3. To maintain connecting rod alignment
 4. To ensure proper bearing lubrication
- 3-57. What bearing size will best fit a crankshaft that has been reground?
1. Standard
 2. Undersized
 3. Oversized
 4. Custom
- 3-58. The vibration damper is a device designed to perform what function?
1. To balance camshaft speed with crankshaft speed
 2. To reduce twisting strain on the crankshaft
 3. To brake the flywheel during engine speed reduction
 4. To reduce flywheel vibration
- 3-59. In addition to reducing engine speed fluctuations, the flywheel often serves what other purpose?
1. As a power takeoff of the camshaft and a pressure surface for the clutch
 2. As a pressure surface for the clutch and starting system gear
 3. As a starting system gear and a power takeoff for the fuel pump
 4. As a power takeoff for the fuel pump and as a timing reference for the ignition system
- 3-60. What is the purpose of the camshaft?
1. It holds the valves in place
 2. It force gas to the carburetor
 3. It operates the valve mechanism
 4. It rotates the valves
- 3-61. The camshaft is usually located directly above the crankshaft on which of the following types of engine heads?
1. L-head
 2. F-head
 3. I-head
 4. V-head
- 3-62. What will be the result of an accumulation of carbon on valve seats?
1. It will increase valve life
 2. It will produce cooler operating valves
 3. It will produce positive valve seating
 4. It will cause improper valve closure
- 3-63. What part of an engine must be removed before the valves is accessible?
1. The cylinder head
 2. The exhaust manifold
 3. The intake manifold
 4. The camshaft
- 3-64. During reassembly of an engine, replacing the valves in their original guides will result in what condition?
1. In excessive wear of the valve and guide
 2. In less valve wear
 3. In failure of the valve to seat properly
 4. In noisy valve operation
- 3-65. One procedure for checking valve guide wear involves the use of which of the following tools?
1. A thickness gauge
 2. A depth gauge
 3. A hole gauge and micrometer
 4. A valve guide gauge
- 3-66. When an unusually large amount of a valve seat is removed by grinding, the seat must be narrowed and centered by using what procedure?
1. Using a 45° narrowing stone
 2. Using a 20° narrowing stone and a 70° stone
 3. Using lapping compound
 4. Using grinding compound

- 3-67. Which of the following checks should you make on the valve springs before reinstalling them in the engine?
1. Height
 2. Strength
 3. Warpage
 4. Each of the above

ASSIGNMENT 4

Textbook Assignment: "Principles of Internal Combustion Engines," chapter 3, pages 3-38 through 3-42, and "Internal Combustion Engine Fuel Systems," chapter 4, pages 4-1 through 4-37.

- 4-1. Which of the following procedures is used for installing direct-driven timing gears?
1. Position the gears so that the single marked tooth of one gear is between the two marked teeth of the other gear
 2. Rotate the two gears until their marked teeth can be aligned with a straightedge
 3. Install the timing chain after positioning the crankshaft and camshaft gear
 4. Match the idler gears' marked teeth with those on the camshaft and crankshaft
- 4-2. The back of the typical bearing half is constructed of what type of metal?
1. Cast iron
 2. Bronze only
 3. Steel only
 4. Steel or bronze
- 4-3. Oil moves across the face of a bearing in order to accomplish which of the following actions?
1. Cool the bearing
 2. Lubricate the bearing
 3. Remove dirt from the bearing
 4. All of the above
- 4-4. What happens as oil clearance in bearings becomes greater?
1. Oil flows more quickly through the bearings
 2. Oil flows more slowly through the bearings
 3. Bearings remain cool
 4. Oil pressure increases
- 4-5. A bearing's ability to resist wear is referred to by what term?
1. Embedability
 2. Fatigue resistance
 3. Wear rate
 4. Corrosion resistance
- 4-6. A bearing's ability to withstand repeated stresses without failing is referred to by what name?
1. Embedability
 2. Fatigue resistance
 3. Wear rate
 4. Corrosion resistance
- 4-7. A bearing's ability to withstand being eaten away by the byproducts of combustion is referred to by what name?
1. Embedability
 2. Fatigue resistance
 3. Wear rate
 4. Corrosion resistance
- 4-8. Which of the following is an advantage of the quick engine change (QEC) concept?
1. It prevents excessive downtime of equipment
 2. It eliminates the need for engine overhauling
 3. It increases the number of interchangeable parts available
 4. Each of the above
- 4-9. When a fuel fails to evaporate readily in a cold climate, which of the following conditions will result?
1. Hard starting
 2. Loss of power
 3. Increased fuel consumption
 4. All of the above
- 4-10. The percentage of heat energy developed in a gasoline engine that actually provides power at the flywheel is approximately what percentage of the total heat produced?
1. 10% to 15%
 2. 20% to 25%
 3. 30% to 35%
 4. 40% to 45%

- 4-11. Which of the following conditions results when engine ignition timing is retarded beyond manufacturer's specifications?
1. Overheating
 2. Less fuel consumption
 3. Improved performance
 4. Burned valves
- 4-12. Which of the following conditions requires a mixture richer than 15 pounds of air to 1 pound of gasoline?
1. When starting a cold engine
 2. When accelerating
 3. When operating at a high speed or with a full load
 4. All of the above
- 4-13. What feature of a gasoline tank prevents sediment from entering the remainder of the fuel system?
1. The position of the outlet pipe
 2. The arrangement of the baffles
 3. The design of the outer shell
 4. The location of the filter
- 4-14. What is the function of the fuel pump?
1. To measure the amount of gas that enters the carburetor
 2. To deliver the fuel requirements of the engine
 3. To pump gas from the carburetor to the intake manifold
 4. To pump gas from the carburetor through the gasoline filter into the manifold
- 4-15. What component maintains the proper pressure in the line between the fuel pump and the carburetor?
1. The fuel filter
 2. The fuel gauge
 3. The fuel pump
 4. The sediment bowl
- 4-16. Which of the following pumps delivers fuel only when the float valve in the carburetor is opened?
1. Positive diaphragm
 2. Nonpositive diaphragm
 3. Electric tank unit
 4. Diaphragm
- 4-17. Which of the following conditions lowers the speed at which the molecules of a liquid escape as vapor?
1. Raising the temperature of the liquid
 2. Removing evaporated particles from the air above the liquid
 3. Decreasing air pressure at the surface of the liquid
 4. Lowering the temperatures of the liquid
- 4-18. What is the purpose of the venturi in a carburetor?
1. To lower the atmospheric pressure in the float bowl to force the gasoline through the fuel nozzle
 2. To create a partial vacuum to permit atmospheric pressure to force the fuel from the float bowl
 3. To reduce the rate of vaporization by lowering the pressure of the air entering the carburetor
 4. To spray the fuel in the air by decreasing the speed of the air entering the carburetor
- 4-19. What component varies the amount of fuel-air mixture that enters the intake manifold?
1. The automatic choke
 2. The fuel pump
 3. The throttle valve
 4. The venturi
- 4-20. In the high-speed circuit, a carburetor maintains a fairly constant ratio of fuel to air mixture. Although an enriched mixture is produced, what action of the carburetor prevents an over-rich mixture from entering the intake?
1. It decreases the volume of air through the venturi
 2. It maintains a constant volume of air in the venturi and causing fuel to discharge from the nozzle
 3. It lets more air enter the main nozzle
 4. It lets less air enter the main nozzle
- 4-21. Which of the following fuel-air ratios by weight will normally produce the most power in the high-speed circuit?
1. 12:1
 2. 13:1
 3. 14:1
 4. 15:1

- 4-22. To ensure delivery of the proper fuel-air mixture for all operating conditions, each position of the throttle valve must be synchronized with the position of what other component?
1. The power jet
 2. The metering rod
 3. The vacuum step-up
 4. The venturi
- 4-23. What component in the carburetor injects a small amount of fuel into the intake when the throttle is opened quickly?
1. The venturi
 2. The accelerator pump
 3. The throttle body
 4. The high-speed circuit
- 4-24. What is the function of the air-vent check valve in the accelerating pump circuit?
1. To prevent the accelerating jet flow from flowing at constant throttle openings
 2. To allow air to enter the passage connecting the pump cylinder and accelerating jet
 3. To prevent fuel from being discharged back into the bowl through the air-vent passage
 4. All of the above
- 4-25. A choke alters the fuel-air mixture that enters the manifold of a cold gasoline engine during starting by performing what function?
1. Admitting less air
 2. Admitting more air
 3. Admitting less fuel and more air
 4. Admitting more fuel and more air
- 4-26. What component in the choke circuit needs the assistance of a coiled spring on the end of the choke shaft and pressure to operate properly?
1. The spring-loaded poppet valve
 2. The off-center choke valve
 3. The needle valve
 4. The power jet
- 4-27. In the operation of an automatic choke, helping to close the choke valve and holding it closed is accomplished by what means?
1. By low intake manifold pressure
 2. The thermostatic spring
 3. By hot air from the exhaust manifold
 4. By a high velocity air passing through the carburetor air horn
- 4-28. Which of the following troubles within the carburetor system will cause an engine to use an excessive amount of fuel?
1. A high float level
 2. A defective radiator thermostat
 3. An air leak in the intake manifold
 4. A weak accelerator spring
- 4-29. Why are air cleaners used on all internal-combustion engines?
1. To protect the carburetor from excessive wear
 2. To keep dust and other foreign matter out of the engine
 3. To lower the moisture content of the air entering the engine
 4. To eliminate carburetor icing on humid days
- 4-30. Why is the dry-type air cleaner preferable to the wet-type?
1. It requires less maintenance
 2. It aids in conserving petroleum
 3. It is more efficient
 4. It is cleanable
- 4-31. Which of the following functions is performed by the intake manifold?
1. Admitting outside air to the air cleaner
 2. Providing an air passage between the air cleaner and the carburetor
 3. Forming a passage for the fuel-air mixture to enter the cylinders
 4. Passing air from the engine to the muffler
- 4-32. The purpose of the exhaust manifold is to perform what function?
1. To take air from the inside to the air filter
 2. To allow used gases to pass from the cylinders
 3. To pass air from the filter to the carburetor
 4. To pass air and fuel from the carburetor to the engine
- 4-33. What is the purpose of the manifold heat valve?
1. To create a "hot spot" around the exhaust manifold
 2. To run the windshield wipers in case intake manifold vacuum is insufficient
 3. To heat the fuel-air mixture in cold weather until the engine warms up
 4. To provide additional heat inside the vehicle in cold weather

- 4-34. When the manifold heat control valve sticks, which of the following internal parts will be damaged?
1. The exhaust valves
 2. The intake valves
 3. The piston rings
 4. The pistons
- 4-35. Which of the following conditions is an indication of a clogged muffler?
1. Engine not developing maximum power
 2. Difficulty in starting
 3. Engine operating at higher than normal temperature
 4. Each of the above
- 4-36. What factor makes it possible to ignite the fuel-air mixture of a diesel engine without the use of a spark as in a gasoline engine?
1. The ignition temperature of diesel fuel is low
 2. The compression temperature of the diesel engine is high
 3. The compression ratio of the diesel engine is low
 4. The speed of diesel engine moving parts is high
- 4-37. Which of the following items is considered a disadvantage of a diesel engine as compared to a gasoline engine?
1. High cost of manufacture
 2. Heavier construction necessary to withstand high compression pressure
 3. Difficulty in starting
 4. Each of the above
- 4-38. Which of the following sequences of events characterizes the operation of a diesel engine?
1. The fuel and air are mixed; the partly vaporized mixture enters on the intake stroke; and a spark ignites it near the end of the compression stroke
 2. The fuel and air are mixed; the mixture enters on the compression stroke; and a spark ignites it near the end of the compression stroke
 3. The air enters on the intake stroke; the fuel is injected near the end of the compression stroke; and the high temperature ignites the fuel
 4. The fuel enters on the intake stroke; the air is injected under pressure near the end of the compression stroke; and the high temperature ignites the fuel
- 4-39. Which of the following characteristics of diesel fuel increases the need for better filtering than that required for gasoline?
1. Viscosity
 2. Ignition quality
 3. Volatility
 4. Moisture content
- 4-40. The cetane value of a diesel fuel is a measurement of which of the following properties?
1. A volatility characteristic
 2. An antiknock characteristic
 3. An ignition characteristic
 4. A viscosity characteristic
- 4-41. Which of the following combustion chamber designs requires the highest fuel injection pressure?
1. Open
 2. Precombustion
 3. Turbulence
 4. Hypercycle
- 4-42. When precombustion chambers are used on a diesel engine, which of the following factors causes the greatest fuel atomization?
1. Turbulence within the cylinders
 2. High fuel injection pressure
 3. Dispersion of the fuel from the multi-orifice fuel injector
 4. Rapid air movement within the pre-combustion chamber
- 4-43. Which of the following components prevents an engine from overspeeding but allows it to meet changing load conditions?
1. The fuel pump
 2. The carburetor
 3. The throttle valve
 4. The governor
- 4-44. Which of the following factors are used to classify diesel engine governors?
1. The method by which the governor operates the fuel control mechanism
 2. The forces that acts on the governor and cause it to operate
 3. The function for which the governor is designed to perform
 4. Each of the above

- 4-45. What part of the spring-loaded centrifugal governor does the manual throttle directly adjust?
1. The linkage between the flyballs and the injectors
 2. The spring tension
 3. The position of the flyballs
 4. The centrifugal-force generator
- 4-46. For engine speed to stabilize, what action must occur within the centrifugal governor?
1. Centrifugal force must overcome spring tension
 2. Spring tension must overcome centrifugal force
 3. Centrifugal force and spring tension must balance fuel pressure
 4. Centrifugal force and spring tension must be equalized
- 4-47. A simple mechanical governor can be distinguished from a hydraulic governor by identifying which of the following characteristics?
1. The mechanical linkage between the governing unit and the fuel-control mechanism
 2. The set of two rotating flyweights
 3. The spring device
 4. The sensitivity control
- 4-48. When faulty governor operation allows an engine to overspeed, which of the following procedures should you use to stop the engine?
1. Repair the governor and then secure the engine
 2. Shut off the fuel supply
 3. Stall the engine by overloading it
 4. Flood the engine with fuel
- 4-49. When a diesel engine uses two fuel filters, the primary filter will be the filter between what components?
1. Fuel pump and the carburetor
 2. Supply tank and the fuel supply pump
 3. Injection pump and the fuel nozzle
 4. Fuel supply pump and the injection pump
- 4-50. Which of the following filters is designed with the greatest filtering quality?
1. A full-flow
 2. A cloth-bag
 3. A metal-disc
 4. A fabric
- 4-51. The relief valve in the fuel supply pump opens during which of the following conditions?
1. When the fuel filter restricts fuel flow to the injection pump
 2. When the gears in the pump are worn
 3. When the springs in the pump are weak
 4. When a fuel line develops a leak
- 4-52. What injection function ensures uniform engine speed with a uniform power output?
1. The metering
 2. The timing
 3. The atomization
 4. The rate control
- 4-53. If fuel is injected into the cylinder too late in the cycle, which of the following conditions occurs?
1. Engine overspeed
 2. Low exhaust temperature
 3. Smoky exhaust
 4. Excessive wear
- 4-54. In the mechanical flyweight governor, the action of the weights in their retainer is transmitted through what components?
1. A sleeve to the governor arm and a linkage to the metering valve
 2. A governor arm to the sleeve and a linkage to the metering valve
 3. A sleeve to the governor arm and a metering valve to the linkage
 4. A governor arm to the sleeve and a metering valve to the linkage
- 4-55. Fuel is drawn from the final fuel filter into the pump through the inlet strainer by what component?
1. The metering valve
 2. The cam lobe
 3. The vane-type transfer pump
 4. The delivery valve
- 4-56. The amount of fuel needed by the engine is determined by what component?
1. The metering valve
 2. The cam lobe
 3. The vane-type transfer pump
 4. The delivery valve

- 4-57. What component forces the plungers down towards each other, discharging the fuel from the cylinder through the outlet port into the outlet passage in the hydraulic head and the fuel injection line connected to this passage?
1. The metering valve
 2. The cam lobe
 3. The vane-type transfer pump
 4. The delivery valve
- 4-58. The end plate of the Roosa-Master fuel pump provides which of the following functions?
1. It provides for fuel passage and absorbs end thrust of the transfer pump
 2. It houses the pressure regulator valve
 3. It houses the primer bypass spring
 4. All of the above
- 4-59. The maximum amount of fuel that can be injected at rated engine speed is controlled by what component?
1. The torque screw
 2. The delivery valve
 3. The leaf spring
 4. The multi-orifice tip
- 4-60. The unit injectors of a diesel engine are actuated by what means?
1. Camshaft lobes
 2. Pushrods and rocker arms
 3. Fuel pressure
 4. Spring tension
- 4-61. Which of the following conditions must exist in the unit injector for it to inject fuel?
1. The lower port must be open, and the upper port must be closed
 2. The lower port must be closed, and the upper port must be open
 3. The lower and upper ports must be closed
 4. The lower and upper ports must be open
- 4-62. What is the primary difference between the distribution-pressurized and the unit-injection types of fuel injectors?
1. The distribution-pressurized type delivers enough pressure to overcome the cylinder pressure, whereas the unit-injection type does not
 2. The unit-injection type contains the injection nozzle and pressurization pump in one unit
 3. The unit-injection type requires a spring-loaded bypass valve on the header to assist in maintaining constant fuel pressure
 4. The distribution-pressurized type contains the injection nozzle and pressurization pump in one unit
- 4-63. What is heated by the preheaters used on a diesel engine to assist in cold weather starting?
1. The fuel
 2. The inlet air
 3. The lube oil
 4. The coolant
- 4-64. When an operating engine runs too hot or too cold, which of the following conditions could be the cause?
1. A malfunctioning thermostat
 2. A defective pressure cap
 3. A slipping fan belt
 4. Each of the above

ASSIGNMENT 5

Textbook Assignment: “Internal Combustion Engine Fuel Systems,” chapter 4, pages 4-37 through 4-47, and “Internal Combustion Engine Cooling and Lubricating Systems,” chapter 5, pages 5-1 through 5-24, and “Automotive Electrical Systems and Equipment,” chapter 6, pages 6-1 through 6-14.

- 5-1. A diesel engine has been operating normally and suddenly begins to puff thick, black smoke from its exhaust. Which of the following malfunctions would cause this problem?
1. An air lock in the fuel lines
 2. A grease-clogged fuel injector
 3. Dirt or grit holding a spray nozzle open
 4. Water blocking an expansion loop in the fuel line
- 5-2. When water enters the fuel system of a diesel engine, which of the following conditions can result?
1. An overspeeding of the engine
 2. Missing and stalling of the engine
 3. Smoking exhaust emissions
 4. All of the above
- 5-3. When air is known to be in the fuel system of a diesel engine, which of the following procedures should you use to remove the air?
1. Completely fill the fuel tank
 2. Operate the engine at high idle for a short period of time
 3. Bleed the fuel system
 4. Idle the engine until its operating temperature is reached
- 5-4. While testing the injectors of a diesel engine that fails to operate properly, you cut out one cylinder at a time and observe engine operation. Which of the following conditions indicates a defective injector for the cut-out cylinder?
1. The defect is more pronounced
 2. Irregular operation of the engine remains unchanged
 3. Irregular operation of the engine is eliminated
 4. Engine speed increases
- 5-5. If you do not have special equipment available to service a defective injector, which of the following actions should you take?
1. Replace it
 2. Repair it
 3. Clean it
 4. Blow it out with air
- 5-6. What fluid is commonly used to clean injectors?
1. Water
 2. Gasoline
 3. Wood alcohol
 4. Diesel fuel
- 5-7. When timing a unit injector, the engine speed control lever should be in what position?
1. Idle-speed
 2. Shut-off
 3. Centered
 4. Maximum speed
- 5-8. When equalizing injectors, you should NOT turn the adjusting screws on the control rack beyond what maximum limit?
1. 1/4 turn
 2. 1/2 turn
 3. 3/4 turn
 4. 1 turn
- 5-9. Cylinder wall temperature should not be allowed to exceed 500°F for what reason?
1. Because the combustion limit of the lubricating oil may be exceeded
 2. Because no radiator coolants will withstand higher temperature
 3. Because excess exhaust gases build up faster than they can be expelled
 4. Because lubricating oil films tend to break down with loss of lubricating properties

- 5-10. What is the approximate combined percentage of engine heat dissipated through the cooling, lubricating, and fuel systems?
1. 15%
 2. 25%
 3. 35%
 4. 45%
- 5-11. In an air-cooled engine, cooling efficiency is dependent on which of the following factors?
1. Heat conductivity of the engine's metallic parts
 2. Volume of air that circulates around engine surfaces
 3. Difference between air temperature and engine temperature
 4. Each of the above
- 5-12. Why are cylinders on an air-cooled engine mounted independently?
1. To reduce engine weight
 2. To expose more surface area to the cooling medium
 3. To eliminate the need for cooling system maintenance
 4. To provide easy access to the crankcase
- 5-13. Which of the following components is required on all stationary air-cooled engines?
1. Baffles
 2. Thermostats
 3. Fans or blowers
 4. Radiators
- 5-14. Coolant in a liquid cooling system flows directly from the water pump to what other component?
1. The bottom of the radiator
 2. The cylinder block
 3. The cylinder head
 4. The top of the radiator
- 5-15. The efficiency of a liquid cooling system is affected by which of the following factors?
1. Size of the coolant passages in the engine
 2. Capacity of the water pump
 3. Size of the radiator
 4. Each of the above
- 5-16. How do radiator fins contribute to cooling system efficiency?
1. They hold the tubes in a position that allows maximum contact with the airflow
 2. They increase heat dissipation by enlarging the area exposed to airflow
 3. They increase heat dissipation by enlarging the surface area exposed to the coolant
 4. They direct the flow of air to the hottest parts of the radiator
- 5-17. A radiator is equipped with a 12-pound pressure cap. What effect does this cap have on the boiling point of the coolant?
1. Lowers it to 36°F
 2. Raises it to 36°F
 3. Lowers it to 3°F
 4. Raises it to 3°F
- 5-18. You should be careful when removing the cap from a hot, pressurized radiator to avoid which of the following conditions?
1. A rapid cooling of the engine
 2. An excessive coolant loss
 3. Being burned by the hot coolant
 4. Collapsing the radiator hoses
- 5-19. Which of the following is a likely cause of noise, vibration, and frequent water pump failure?
1. An improperly adjusted drive belt
 2. A bent fan blade
 3. A strong solution of antifreeze
 4. Excessive cooling system pressure
- 5-20. Why are thermostats used in automotive cooling systems?
1. To control engine operating temperatures
 2. To prevent crankcase sludge buildup
 3. To reduce fuel consumption
 4. All of the above
- 5-21. What happens to a wide-open thermostat when its bellows or pellet ruptures?
1. It closes completely
 2. It remains wide open
 3. It assumes a half-open, half-closed position
 4. The engine shuts off
- 5-22. The expansion tank in a closed cooling system performs which of the following functions?
1. It increases the cooling system's capacity
 2. It eliminates the need for a pressure cap
 3. It prevents coolant loss
 4. Each of the above

- 5-23. What percentage of antifreeze is needed in a cooling system to provide maximum protection from freezing?
1. 40%
 2. 50%
 3. 60%
 4. 70%
- 5-24. To prevent the unwanted aftereffects of using a cleaning compound in an engine cooling system, you should perform which of the following actions?
1. Fill the system with a 60% solution of antifreeze
 2. Reverse flush the cooling system
 3. Use a neutralizing solution
 4. Operate the engine at high temperature for 10 minutes
- 5-25. When adding antifreeze to a cooling system, you do NOT need to do which of the following steps?
1. Determine the capacity of the cooling system
 2. Thoroughly inspect the cooling system components
 3. Mix the antifreeze with water before adding it to the cooling system
 4. Observe manufacturer's safety precautions for the antifreeze
- 5-26. After adding antifreeze to a cooling system, you should perform which of the following procedures?
1. Fill the radiator to operating capacity with water
 2. Operate the engine to mix the solution
 3. Check the solution with an antifreeze hydrometer
 4. Each of the above
- 5-27. When preparing to check a cooling system to determine if exhaust gases are entering the coolant, you do NOT need to remove which of the following components?
1. The lower radiator hose
 2. The upper radiator hose
 3. The thermostat
 4. The fan belt
- 5-28. By testing coolant with a hydrometer, you can determine if the coolant will provide adequate protection against which of the following conditions?
1. Leaking
 2. Clogging
 3. Freezing
 4. Boiling
- 5-29. For what reason will testing an antifreeze solution when its temperature is below 50°F result in a false reading?
1. Antifreeze changes color when cooled
 2. The solution is not thin enough
 3. Water and antifreeze are not soluble at this temperature
 4. Water tends to expand at this temperature
- 5-30. When back flushing the cooling system fails to unclog the water jacket, which of the following actions should you take?
1. Remove the cylinder head(s) and boil it/them in a cleaning solution
 2. Remove the core hole plugs and flush directly through the openings
 3. Remove the old thermostat and replace it with one having a lower opening temperature
 4. Replace the water pump or install a larger impeller
- 5-31. For what reason is a very small leak easier to detect in cooling systems that contain an antifreeze solution than in those that do not?
1. Antifreeze leaves a residue and water does not
 2. More antifreeze leaks through than water
 3. Antifreeze does not evaporate as fast as water
 4. Antifreeze is colored and water is not
- 5-32. After shutting down an engine that has been running for some time, you can check the radiator to determine if it is partially clogged by performing what test?
1. Taking the temperature of the coolant in the lower radiator outlet
 2. Taking the temperature of the coolant in the upper radiator tank
 3. Feeling the top and bottom of the radiator core with your hand
 4. Checking the cooling system for leaks

- 5-33. When a water pump fails to circulate enough coolant, the problem is normally caused by what malfunction?
1. A loose fan belt
 2. Eroded impeller blades
 3. A worn pump housing
 4. Faulty shaft bearings
- 5-34. Correct fan belt tension is determined by measuring what property?
1. The distance between the belt pulleys
 2. The width of the belt
 3. The deflection of the belt between pulleys
 4. The length of the fan belt
- 5-35. What is the primary function of an engine's lubrication system?
1. To reduce friction
 2. To prevent overheating
 3. To eliminate engine seizure
 4. To provide a seal between the cylinder and rings
- 5-36. Which of the following is an operating principle of the two-gear type of oil pump?
1. Both gears are independently driven by shafts
 2. Both gears turn in the same direction
 3. Pumping action forces oil to pass between gear teeth
 4. The pump is driven by the camshaft or distributor
- 5-37. Low engine oil pressure is usually indicated by what means?
1. A high engine temperature
 2. A warning light on the instrument panel
 3. A knocking noise coming from the engine
 4. A sudden loss of power
- 5-38. Dirt, water, and sludge do NOT pass through a fixed oil strainer because of which of the following reasons?
1. All oil is collected from the surface of the oil in the oil pan
 2. The mesh in the screen will only allow the oil to pass
 3. The strainer is located above the bottom of the oil pan
 4. The strainer is equipped with a 3-micron filter
- 5-39. Which of the following is an advantage of using a full-flow oil filter?
1. It has the capacity to strain all of the oil supplied by the oil pump
 2. It never permits any unfiltered oil to reach the moving parts of the engine
 3. It does not need changing as often as other types of filters
 4. Each of the above
- 5-40. Which of the following lubricating systems lubricates the valve mechanisms by oil droplets and mist?
1. A splash system
 2. A combination splash and force-feed system
 3. A force-feed system
 4. A full force-feed system
- 5-41. Which of the following lubricating systems uses oil under pressure to lubricate the rod bearings, while the piston pins are splash lubricated?
1. A splash system
 2. A combination splash and force-feed system
 3. A force-feed system
 4. A full force-feed system
- 5-42. Which of the following factors determines the frequency of engine oil changes for support equipment?
1. The preventative maintenance schedule
 2. Climatic conditions
 3. Adverse operating conditions
 4. All of the above
- 5-43. Which of the following types of oil filters must be disconnected from the oil lines before the filter can be dismantled?
1. A drain plug equipped partial-flow type
 2. A non-replaceable element type
 3. An external-bypass, screw-on type
 4. A non-drain equipped, partial-flow type
- 5-44. Assume that an operator reports that an item of support equipment has a low oil pressure reading. Which of the following conditions could cause the problem?
1. A defective oil pump
 2. A defective oil pressure gauge
 3. An improper grade of oil or low oil level
 4. Each of the above

- 5-45. A constant high oil pressure reading indicates which of the following conditions?
1. Worn engine bearing
 2. Engine overheating
 3. Blocked oil passages
 4. Diluted oil
- 5-46. What is the best method to determine how an oil pump is driven?
1. Remove the distributor to check whether or not it has a gear on the end of its shaft
 2. Remove the oil pan to notice the way the pump is mounted
 3. Consult the manufacturer's maintenance manual
 4. Remove the oil pump to see whether it has a slot or a gear on the end of its shaft
- 5-47. Symbols are used to represent components in which of the following types of diagrams?
1. Isometric
 2. Schematic
 3. Wiring
 4. Block
- 5-48. Detailed circuitry information concerning electrical systems is provided in which of the following diagrams?
1. Wiring
 2. Schematic
 3. Pictorial
 4. Block
- 5-49. What manual should you consult to find the proper wiring harness or proper wire color code for a piece of support equipment?
1. The applicable support equipment manual
 2. The universal wiring harness manual
 3. The support equipment standard wiring guide
 4. Your Nonresident Training Course
- 5-50. In the alphanumeric wiring identification code, what alphabet letter denotes dc power?
1. L
 2. X
 3. P
 4. D
- 5-51. Wires passing through a hole in a metal frame should be protected by what type of component?
1. A wire braid
 2. A piece of tubing
 3. A wrap of celluloid tape
 4. A rubber grommet or friction tape
- 5-52. When work is performed on an energized circuit, which of the following precautions should be taken?
1. An assistant should be stationed near the main switch
 2. The worker should be insulated from ground
 3. An experienced worker should be chosen
 4. All of the above
- 5-53. What material should you use to cover the handles of all metal tools used for working on or near electrical circuits?
1. Barrier tape
 2. Friction tape
 3. Rubber insulating tape
 4. Paper tape
- 5-54. What factor determines the terminal voltage of a battery?
1. The number of cells connected in series
 2. The spacing between the cells
 3. The spacing between the plates
 4. The size of the plates
- 5-55. The basic test that shows the condition or charge of a lead-acid cell is based on what measurement?
1. The percentage of sulfuric acid that remains in the electrolyte
 2. The percentage of lead sulfate deposited on the positive plates
 3. The percentage of lead peroxide remaining on the positive plates
 4. The percentage of spongy gray lead remaining on the negative plates
- 5-56. The hydrometer reading of a lead-acid battery is 1.260 at a cell temperature of 30°F. What is the specific gravity of the battery electrolyte?
1. 1.220
 2. 1.240
 3. 1.260
 4. 1.280

- 5-57. What causes the value of the charging current to change in a constant-voltage battery charger?
1. The battery increasingly resists charging voltage as its own voltage increases
 2. A clock-actuated rheostat adjusts the current value
 3. A rectifier tube automatically adjusts the current value
 4. The operator changes plug-in positions to lower the charger's output at half-hour intervals
- 5-58. Which of the following practices should you observe when charging batteries?
1. Remove each battery from the charger for a 10-minute cooling period when half charged
 2. Before charging, completely remove the vent caps in order to prevent accumulation of gases
 3. During charging, record hydrometer readings frequently to determine if the battery is charging properly
 4. Before charging, add sulfuric acid to any cell in which the electrolyte is below the plates
- 5-59. For what reason does a discharged battery freeze if it is left in a freezing climate?
1. Its plates absorb water from the electrolyte
 2. Its separators hold more water than the electrolyte holds in suspension
 3. Its electrolyte reclaims all of the sulfuric acid from the plates
 4. The temperature at which the electrolyte freezes decreases
- 5-60. After a dry-charged battery has been filled with electrolyte, you should wait at least how long before beginning the initial charge?
1. 1 hour
 2. 2 hours
 3. 30 minutes
 4. 10 minutes
- 5-61. In the absence of manufacturer's instructions, a dry-charged battery should receive its initial charge at which of the following rates?
1. 1 ampere per positive plate per cell
 2. 1 ampere per negative plate per cell
 3. 1 volt per positive plate per cell
 4. 1 volt per negative plate per cell
- 5-62. Which of the following items is included in the safe practice of mixing electrolyte for lead-acid batteries?
1. Pouring acid into water slowly and stirring gently
 2. Mixing in a lead-lined tank or heavy plastic container
 3. Neutralizing any spills using bicarbonate of soda or ammonia and fresh water
 4. All of the above
- 5-63. To determine a battery's state of charge and its ability to withstand loads, most manufacturers recommend what type of test?
1. A cell voltage test
 2. A battery load test
 3. A light load test
 4. A high discharge test

ASSIGNMENT 6

Textbook Assignment: "Automotive Electrical Systems and Equipment," chapter 6, pages 6-15 through 6-79.

- 6-1. It is necessary to rectify the output of an automotive alternator for which of the following reasons?
1. Because dc is easier to regulate
 2. Because ac would overcharge the battery
 3. Because all the accessories operate on dc
 4. Because of the variation in amplitude of the ac output caused by the varying speed of rotation
- 6-2. In the left-hand rule for generators, the direction of current flow is indicated by what finger?
1. The thumb
 2. The forefinger
 3. The middle finger
 4. The little finger
- 6-3. The commutator in a dc generator is constructed of what material?
1. Copper
 2. Steel
 3. Iron
 4. Carbon
- 6-4. Which of the following parts are common to both alternators and dc generators?
1. Rotor, stator, and a device for extracting a dc output
 2. Rotor, stator, a commutator, and brushes
 3. Rotor, stator, and a bridge rectifier
 4. Rotor, stator, and slip rings
- 6-5. Which of the following statements describes an automotive alternator?
1. It has rotating fields, a stationary armature, and no brushes
 2. It has stationary fields, a rotating armature, and no brushes
 3. It has rotating fields, a stationary armature, and brushes
 4. It has stationary fields, a rotating armature, and brushes
- 6-6. What component limits the operating rpm of an alternator?
1. The field windings
 2. The bearings
 3. The armature windings
 4. The brushes
- 6-7. Why are semiconductor diodes used instead of metallic rectifiers in modern automotive alternators?
1. Diodes are larger
 2. Diodes can carry more current
 3. Diodes are easier to replace
 4. Diodes last longer
- 6-8. What total number of positive and negative diodes is necessary to provide full-wave rectification of an alternator's three-phase ac output?
1. 3 positive or negative
 2. 2 positive, 2 negative
 3. 1 positive, 1 negative
 4. 3 positive, 3 negative
- 6-9. A test lamp lights when it is connected between a slip ring and the rotor shaft. This test result indicates what condition of the rotor winding?
1. They are open
 2. They are electrically sound
 3. They are grounded
 4. They are shorted
- 6-10. A diode being tested with an ohmmeter gives one high and one low reading. This test result indicates what condition of the diode?
1. It is grounded internally
 2. It is open internally
 3. It is electrically sound
 4. It is shorted internally
- 6-11. Which of the following equipment should you use to install or remove an alternator's diodes?
1. A hammer and a soft punch
 2. A press and special tools only
 3. A vise and locally manufactured adapters only
 4. A press and special tools or a vise and locally manufactured adapters

- 6-12. When replacing the bearing in the drive frame end of an alternator, you should fill it with grease to what specified level?
1. 1/4 full
 2. 1/2 full
 3. 3/4 full
 4. Completely full
- 6-13. Resistor R2 in the three-unit vibrating contact voltage regulator serves which of the following purposes?
1. It reduces arcing at the reverse-current relay contact points
 2. It reduces arcing at the voltage regulator relay contact points
 3. It reduces arcing at the current regulator relay contact points
 4. Both 2 and 3 above
- 6-14. In an ac generator regulator, a reverse current relay is NOT needed because of what factor?
1. The field relay performs the reverse current relay function
 2. A capacitor on the generator builds up a charge that is equal to the battery's voltage and opposite the battery's polarity
 3. Diodes in the alternator prevent reverse current flow
 4. The voltage regulator performs the reverse current relay function
- 6-15. At the instant the ignition switch is closed, and before any relay movement occurs, a path is completed for current flow through what component?
1. The field relay winding
 2. The voltage regulator winding
 3. The generator field winding
 4. The generator relay winding
- 6-16. In the semi-transistorized, two-unit, vibrating-contact regulator, the field circuit to ground is completed through which of the following paths?
1. The emitter-collector of the transistor
 2. The emitter-base of the transistor
 3. The voltage regulator contact points
 4. All of the above
- 6-17. In the semi-transistorized, two-unit, vibrating-contact regulator, the field circuit to ground is completed through which of the following paths?
1. The emitter-collector of the transistor
 2. The emitter-base of the transistor
 3. The voltage regulator contact points
 4. All of the above
- 6-18. The diode connected across the generator rotor winding serves what purpose?
1. To protect the transistor from surge voltage
 2. To balance the voltages on each side of the field winding
 3. To provide additional rectification of generator dc output
 4. To prevent high voltage buildup across the field relay contacts
- 6-19. Fine adjustments on the fully-transistorized ac regulator should be made by performing what action?
1. By turning the slotted screw on the potentiometer
 2. By relocating the screw in the base of the regulator
 3. By varying spring tension of the field relay
 4. By varying spring tension of the reverse-current relay
- 6-20. The voltage required to force a spark across the spark plug electrodes is approximately what voltage?
1. 10,000 volts
 2. 20,000 volts
 3. 30,000 volts
 4. 40,000 volts
- 6-21. The battery ignition system consists of what total number of circuits?
1. One
 2. Two
 3. Three
 4. Four
- 6-22. What is the purpose of the battery ignition system?
1. To create the high voltage necessary to fire the spark plug
 2. To provide 12 volts to operate the electrical accessories
 3. To provide the high voltage necessary for charging the battery
 4. To provide the low voltage necessary to fire spark plugs

- 6-23. The primary winding of the ignition coil consists of a few hundred turns of heavy wire wrapped around what type of core?
1. A water core
 2. A lead core
 3. A case-hardened steel core
 4. A laminated soft-iron core
- 6-24. What is the purpose of breaker points?
1. To open the primary circuit
 2. To close the primary circuit
 3. To open the secondary circuit
 4. To close the secondary circuit
- 6-25. In what manner, if any, is the capacitor (condenser) wired in relation to the breaker points?
1. In series
 2. In series-parallel
 3. In parallel
 4. None, the capacitor is not wired to the points
- 6-26. Which of the following components are NOT housed in the distributor?
1. The rotor
 2. The spark plug
 3. The breaker points
 4. The breaker capacitor
- 6-27. As engine speed increases, the spark is advanced by what component?
1. The camshaft
 2. The coil
 3. The distributor
 4. The crankshaft timing gear
- 6-28. The vacuum-type spark advance mechanism is directly connected between what two components?
1. The carburetor and spark plugs
 2. The spark plugs and distributor
 3. The distributor and carburetor
 4. The distributor and the coil
- 6-29. In addition to extending periods between engine tune-ups, which of the following advantages does the transistorized ignition system have over a conventional ignition system?
1. An extended breaker point life
 2. A higher available voltage
 3. A quicker operation
 4. All of the above
- 6-30. What type of battery ignition system uses no breaker points?
1. Conventional
 2. Contact-controlled
 3. Transistor-controlled magnetic pulse
 4. Magneto
- 6-31. Which of the following factors causes flash-over on a coil tower?
1. External moisture or dirt on the tower
 2. Internal corrosion within the tower
 3. The high voltage lead not being fully seated in the tower
 4. Each of the above
- 6-32. As much as 40 percent more voltage is required to fire the plugs when coil polarity is reversed. What results from this higher voltage requirement?
1. Engine misfiring
 2. Hard starting
 3. Eventual coil failure
 4. Each of the above
- 6-33. What effect does excessive breaker point gap have on the ignition system?
1. Extended saturation time for the coil, and low-speed missing
 2. Reduced saturation time for the coil, and high-speed missing
 3. Extended saturation time for the coil, and high-speed missing
 4. Reduced saturation time for the coil, and low-speed missing
- 6-34. Which of the following statements defines dwell?
1. The distance, in degrees of crankshaft rotation, that the breaker cam turns from the time the points close until they open again
 2. The distance, in degrees of breaker cam rotation, that the breaker cam turns from the time the points open until they close again
 3. The distance, in degrees of engine cam rotation, that the engine cam turns from the time the points open until they close again
 4. The distance, in degrees of breaker cam rotation, that the breaker cam turns from the time the points close until they open again

- 6-35. Which of the following statements is true regarding the relationship between dwell and point gap?
1. They are the same
 2. They are indirectly proportional
 3. They are directly proportional
 4. They are not related
- 6-36. Engine oil or low-temperature grease should NOT be used to lubricate the breaker cam for what reason?
1. Only special oil is to be used
 2. It will be thrown off the cam and onto the points
 3. It causes rapid deterioration of the point-rubbing block
 4. The felt wick will not hold it
- 6-37. A distributor is being installed and it will NOT bottom. What must be done?
1. Remove the distributor and turn the shaft one tooth
 2. Install the hold down bolt and pull the distributor down
 3. Hold firm pressure on the distributor and crank the engine to align the oil pump
 4. Place no pressure on the distributor and crank the engine to align the oil pump
- 6-38. Preignition can be caused by which of the following conditions?
1. A piece of glowing carbon
 2. An overheated spark plug
 3. A hot valve
 4. Each of the above
- 6-39. To check the air gap in an electronic distributor, which of the following measuring devices is used?
1. Wire gauge
 2. Nonmetallic feeler gauge
 3. Micrometer
 4. Depth gauge
- 6-40. The ballast resistor used in the Chrysler electronic ignition is of what value?
1. 0.5 ohm only
 2. 1.2 ohms only
 3. 5.0 ohms only
 4. 0.5 and 5.0 or 1.2 ohms, depending upon application
- 6-41. What pin in a dual ballast resistor/5-pin electronic control unit provides the magnetic pickup's electrical ground to the chassis?
1. 1
 2. 2
 3. 5
 4. 4
- 6-42. Which of the following components is NOT a part of a modern SE secondary ignition system?
1. The distributor cap
 2. The vacuum advance mechanism
 3. The rotor button
 4. The high-tension leads
- 6-43. Electrical starters used on SE are remotely controlled by which of the following devices?
1. A thermostatic clutch
 2. A push-button switch
 3. An ignition switch
 4. Both 2 and 3 above
- 6-44. The armature coils of a starter motor are arranged and connected in what configuration?
1. Series
 2. Parallel
 3. Series-parallel
 4. Compound
- 6-45. What is the normal starter pinion and flywheel ring gear ratio?
1. 5:1 to 10:1
 2. 10:1 to 16:1
 3. 15:1 to 20:1
 4. 16:1 to 25:1
- 6-46. When the armature shaft of the starter motor begins to rotate, what force or component prevents the bendix drive from rotating with it?
1. Spring tension
 2. An electromagnetic field
 3. Inertia of the counterweight
 4. The threaded sleeve
- 6-47. After an engine starts, what causes the pinion gear to disengage from the ring gear?
1. Inertia
 2. Drive spring
 3. Pinion spring
 4. Speed of the ring gear

- 6-48. A starter that uses an overrunning clutch drive is disengaged from the ring gear as a result of what action?
1. The action of the solenoid return spring
 2. The clutch spring compressing
 3. The ring gear speed overrunning the starter speed
 4. The clutch plunger springs being fully expanded
- 6-49. When a starter solenoid is energized, its plunger is pulled in by what action?
1. The remote control circuit
 2. The combined magnetic fields of the pull-in and hold-in windings
 3. The opposed magnetic fields of the pull-in and hold-in windings
 4. The action of the solenoid shift lever
- 6-50. The starter lockout relay is opened by what force?
1. Engine oil pressure
 2. Intake manifold vacuum
 3. Air pressure
 4. Generator output voltage
- 6-51. If a vehicle's starter fails to function, what is the first component that you should check?
1. The remote-control relay
 2. The starter switch
 3. The starter motor
 4. The battery
- 6-52. If the starter is operated for too long, it can be damaged due to overheating. To prevent this, what procedure should be followed?
1. 1-minute operation followed by a cooling period of 30 seconds
 2. 1-minute operation followed by a cooling period of 10 seconds
 3. 30-minute operation followed by a cooling period of 2 seconds
 4. 30-second operation followed by a cooling period of 2 minutes
- IN ANSWERING ITEMS 6-53 AND 6-54, REFER TO FIGURE 6-73 IN THE TEXTBOOK
- 6-53. With the voltmeter connected at the points for test 3, the maximum allowable voltage drop is what voltage?
1. 0.1 volt
 2. 0.5 volt
 3. 1.5 volts
 4. 6.5 volts
- 6-54. A voltage drop higher than the maximum allowable for test 3 indicates that the relay or solenoid is in what condition?
1. The contacts are burned
 2. The terminal posts are loose
 3. The coil is open
 4. The case is not grounded
- 6-55. Which of the following types of support equipment is equipped with a start counter?
1. The GTC-85
 2. The NC-8A
 3. The A/M32C-17
 4. The A/S32A-31A
- 6-56. Concerning the coil-type fuel gauge, which of the following statements is true?
1. Zero current is drawn when full is indicated
 2. Maximum battery drain occurs when the tank is one-half full
 3. The gauge reading is not affected by battery voltage variations
 4. Variations in hydrostatic pressure act against the float to indicate the various fuel levels
- 6-57. The Bourdon tube tends to straighten out as a result of what action?
1. The thermal expansion of the tube's metal
 2. The gas or liquid pressure within the tube
 3. The force from a spring, gear, and lever arrangement
 4. The current flow that heats the dissimilar metals from which the tube is made
- 6-58. The pressure required to operate the Bourdon tube temperature gauge is developed by which of the following actions?
1. The distortion of a bimetallic strip
 2. The magnetization of the magneto-sensitive rod
 3. The vaporization of the liquid in a bulb that is attached to the Bourdon tube
 4. The normal increase in pressure as a result of expansion of a heated metal
- 6-59. Which of the following automotive gauges can be replaced with an instrument panel warning light?
1. Ammeter
 2. Temperature
 3. Oil pressure
 4. All of the above

- 6-60. The start counter used on the GTC-85 gas turbine records the number of complete engine starts since what specific time frame?
1. The initial or overhaul installation
 2. The last preoperational check
 3. The last periodic check
 4. The last special check
- 6-61. Which of the following statements is true concerning design considerations of speedometers?
1. All speedometers are mechanical in design and hookup
 2. The speedometer and the odometer are driven by separate flexible shafts
 3. Tire size must be considered in the design of the speedometer for a vehicle
 4. The gears that turn the speedometer driveshaft are interchangeable between different types of vehicles
- 6-62. Which of the following statements concerning the operation of the vibrator-type horn is true?
1. When the horn circuit is not energized, the horn contacts are open
 2. When the horn circuit is not energized, the horn contacts are closed
 3. The horn armature winding is connected in parallel with the contacts
 4. The horn armature remains energized as long as the horn push button is depressed
- 6-63. Refer to figure 6-87 in the textbook. The tone and volume of the horn should be adjusted by what procedure?
1. Turning the adjusting nut
 2. Bending the contact arms
 3. Positioning the armature
 4. Turning the diaphragm locknut
- 6-64. The current flow through a flasher unit to the directional signal light is interrupted by which of the following components?
1. The rectifier
 2. The vibrator
 3. The solenoid
 4. The thermostatic element
- 6-65. When the electric windshield wiper is in the high-speed position, what amount of operating current is carried by the shunt field?
1. Zero
 2. A minimum amount
 3. A maximum amount
 4. A fluctuation between the minimum and maximum amount
- 6-66. Auxiliary power receptacles on vehicles provide for application of external power that may be used for what purpose(s)?
1. To start the vehicle's engine
 2. To charge the vehicle's battery
 3. To operate electrical components in the vehicle
 4. All of the above
- 6-67. On a vehicle having four headlights, how is the low beam achieved?
1. By lighting the low-beam filament of all four lamps
 2. By lighting the low-beam filament of the inboard lamps
 3. By lighting the low-beam filament of the outboard lamps
 4. By lighting all filaments, but with a reduced voltage
- 6-68. On a vehicle equipped with blackout lights, regular service lights can NOT be used when the blackout lights are in operation for which of the following reasons?
1. Such vehicles do not have service lights installed
 2. The light switch disables all but the blackout lights
 3. Blackout light voltage is too low to light regular lights
 4. When a blackout condition is ordered, all service lights are removed
- 6-69. Why are relays used in some automotive lighting systems?
1. To make the use of larger lights possible
 2. To reduce voltage losses
 3. To make the use of larger wire possible
 4. To increase voltage

ASSIGNMENT 7

Textbook Assignment: "Power Generating Systems," chapter 7, pages 7-1 through 7-68.

- 7-1. The NC-8A uses what total number of generators to supply both ac and dc power?
1. One dual-purpose generator
 2. One ac and a separate dc generator
 3. One ac generator, and dc voltage is rectified from the ac voltage
 4. One dc generator, and the voltage is obtained from a voltage inverter
- 7-2. When germanium is doped with boron, what is the result?
1. Addition of positive charges
 2. Addition of negative charges
 3. Deletion of positive charges
 4. Deletion of negative charges
- 7-3. When germanium is doped with antimony, what is the result?
1. Addition of positive charges
 2. Addition of negative charges
 3. Deletion of positive charges
 4. Deletion of negative charges
- 7-4. In figure 7-6 of your textbook, what component drops the difference of voltage between E_{in} and E_{out} ?
1. Transistor CR1
 2. Zener diode CR1
 3. Capacitor R1
 4. Resistor R1
- 7-5. Which of the following factors determines if a transistor acts as a switch or amplifier?
1. The type of material (P material or N material) sandwiched between the emitter and collector
 2. The type of material (P material or N material) sandwiched between the emitter and base
 3. The controlling circuit
 4. The operating circuit
- 7-6. Of the four basic tests required in troubleshooting a transistor, what two are the most important?
1. Gain and leakage tests
 2. Breakdown and switching tests
 3. Gain and breakdown tests
 4. Leakage and switching tests
- 7-7. While performing a transistor leakage test with an ohmmeter, you notice a low (but not shorted) reversed resistance exists. This transistor is considered to be in what condition?
1. Open
 2. Breakdown
 3. Shorted
 4. Leaking
- 7-8. A silicon-controlled rectifier (SCR) is a PNP semiconductor switch used where which of the following requirements exists?
1. A very small gate voltage can be used to control high power requirements
 2. Upon removing the gate voltage, the SCR will reverse bias immediately
 3. The load will provide a regenerative feedback to the input lead and cancel the input voltages
 4. All of the above
- 7-9. Permeability of the magnetic amplifier's core material decreases almost to the permeability of air when which of the following conditions occur?
1. Dc current is flowing through the coil
 2. Current flow through the coil is almost zero
 3. The core is not noticeably affected by magnetizing forces
 4. The core is completely saturated (magnetized)
- 7-10. Refer to figure 7-16 in your textbook. What conditions result when the core is moved into the coil?
1. Low load voltage and maximum circuit current flow
 2. Low load voltage and minimum circuit current flow
 3. High load voltage and maximum circuit current flow
 4. High load voltage and minimum circuit current flow

- 7-11. Refer to figure 7-17 in your textbook. The lamp in the load circuit receives maximum voltage when what condition occurs?
1. The ac increases enough to completely saturate the core
 2. The ac decreases enough to allow the core to be completely saturated by the ac voltage
 3. The control current decreases enough to allow the core to become completely saturated
 4. The control current increases enough to completely saturate the core
- 7-12. The magnetic amplifier, shown in figure 7-18 in your textbook, can be improved by using bias windings to accomplish which of the following actions?
1. Eliminate alternating flux in the core material
 2. Preset a magnetic flux in the core material
 3. Convert ac current to magnetic flux in the core material
 4. Convert dc current in the control winding to magnetic flux in the core material
- 7-13. In figure 7-19 in your textbook, the impedance of the load winding of L1 is regulated by what winding(s)?
1. 1-2 of L1
 2. T4 and T5
 3. 5-6 and 7-8 of L1
 4. Both 2 and 3 above
- 7-14. In figure 7-20 in your textbook, for current to flow from point Y to point X in the control windings (L1), line voltage must have what characteristic?
1. It must be at the nominal value
 2. It must be above the nominal value
 3. It must be below the nominal value
 4. It must be at zero
- 7-15. In figure 7-23 in your textbook, the conductors are LEAST affected by the magnetic flux at what position(s)?
1. A and B
 2. A and C
 3. A and D
 4. A only
- 7-16. Which of the following statements concerning ac and dc generators is NOT correct?
1. An ac generator's output is applied by direct connection to the stator; a dc generator's output is applied to a load by using commutator segments and brushes
 2. An ac generator has slip rings and brushes; a dc generator has commutator segments and brushes
 3. A dc generator produces an ac waveform, but uses the commutator segments to rectify to dc
 4. An ac generator uses smooth slip rings and brushes to rectify the pulsed dc waveforms
- 7-17. In a series-wound generator, as the load circuit starts drawing more current, what affect does this have on the voltage output?
1. It increases
 2. It decreases
 3. It remains constant
 4. It is directly proportional to the frequency
- 7-18. In a compound-wound generator, as the load circuit starts drawing more current, what affect does this have on the voltage output?
1. It increases
 2. It decreases
 3. It remains constant
 4. It is directly proportional to the frequency
- 7-19. The rotating field generator shown in figure 7-30 of your textbook contains which of the following components?
1. An ac exciter generator only
 2. A dc exciter generator only
 3. An ac exciter generator and a dc exciter generator
 4. An ac generator and a dc exciter generator
- 7-20. Voltage regulation of the generator, illustrated in view B of figure 7-30 in your textbook, is accomplished by controlling which of the following factors?
1. The number of windings in the generator field
 2. The exciter armature dc output voltage
 3. The number of diode pairs in effect during output load application
 4. The speed of shaft-mounted, rotating rectifiers

7-21. Improper phase sequencing of MEPPs is mostly caused by which of the following conditions?

1. A malfunctioning phase sequencing protector
2. A shorted exciter field winding
3. An improperly installed output power cable
4. Out-of-sequence shutdown procedures, causing reverse motor rotation upon restarting

7-22. In figure 7-32 in your textbook, the illustrated electrical frequency control circuits operate on what concept?

1. Capacitive reactance is independent of frequency
2. Capacitive reactance varies with frequency
3. Resistance varies with frequency
4. Equal voltages are dropped across all components in a series circuit

7-23. The frequency of an ac generator is controlled by controlling what property of the generator?

1. The polarity of the fixed magnetic field
2. The resistance that is in series with the stator
3. The speed of the magnetic field rotation
4. The strength of the magnetic field associated with the rotor

7-24. The brushless generator's operating speed is held within what percent of the generator's nominal speed?

1. 1 or 2 percent
2. 2 or 3 percent
3. 3 or 4 percent
4. 4 or 5 percent

REFER TO FIGURE 7-35 IN YOUR TEXTBOOK TO ANSWER QUESTIONS 7-25 AND 7-26.

7-25. What is the function of L1?

1. It amplifies the input signal
2. It works in conjunction with C4 to reduce voltage ripple
3. It reduces the input signal to Q2 emitter
4. It reduces the input signal to Q3 base

7-26. Capacitors C1, C2, and C6 are a part of what circuit in the voltage regulator?

1. Sensing
2. Amplifying
3. Controlling
4. Feedback

7-27. The dc generator on some MEPPs can be operated intermittently (20 seconds ON, 40 seconds OFF) at 750 amperes for 30 minutes. After such an operating cycle, the generator should be operated at no-load for what amount of time before beginning another 30-minute operating cycle?

1. 1 minute
2. 30 minutes
3. 1 hour
4. 3 hours

7-28. In a circuit that is either inductive or capacitive, apparent power differs from true power for what reason?

1. Because inductors and capacitors are purely resistive
2. Because inductors and capacitors do not draw current
3. Because the circuit voltage and current are not in phase
4. Because the circuit voltage and current are exactly in phase

7-29. The NC-2A MEPP has what type of propulsion system?

1. A hydraulic pump
2. A gasoline engine
3. An ac electric motor
4. A dc electric motor

7-30. When in propulsion mode, engine speed control on the NC-2A is accomplished by the action of what component?

1. The dc generator
2. The engine governor assembly
3. The drive control module assembly
4. The dc motor

REFER TO FIGURE 7-40 IN YOUR TEXTBOOK TO ANSWER QUESTIONS 7-31 THROUGH 7-33.

7-31. What is the designation symbol of the engine oil pressure switch?

1. S11
2. S14
3. S15
4. S19

7-32. What is the designation symbol of the water temperature switch?

1. S11
2. S14
3. S15
4. S19

- 7-33. What is the designation symbol of the engine start switch?
1. S11
 2. S14
 3. S15
 4. S19
- 7-34. As the operator varies pressure on the accelerator pedal, vehicle speed is changed by what action?
1. Varying the reference signal to the generator
 2. Varying the reference signal to the engine governor
 3. Energizing a relay circuit that controls polarity of the dc generator
 4. Switching resistance in series with the traction motor field in or out
- 7-35. In figure 7-43 in your textbook, when an over voltage condition exists, for what reason will an output voltage from the dc generator be stopped?
1. Because K25 energizes and causes K12 to energize
 2. Because K12 energizes and causes K11 to de-energize
 3. Because K11 de-energizes, and contacts B1 and B2 open and remove the generator voltage from pin C of the voltage regulator
 4. Because all of the relay actions above occur, and in the sequence listed
- 7-36. In figure 7-45 in your textbook, the time-delay relay K3 permits what action to take place?
1. An overall warm-up period for all components of the system
 2. The voltage regulator to warm up prior to generator operation
 3. The generator output voltage and frequency to reach rated levels, preventing inadvertent tripping of the voltage and frequency protective relays
 4. The voltage and frequency protective relays to energize before the generator develops an output
- 7-37. The ac over-voltage relay of the NC-8A power plant samples what phase(s) of the ac generator output?
1. A only
 2. B only
 3. C only
 4. A, B, and C
- 7-38. Which of the following conditions will NOT activate the fault circuitry of the NC-8A?
1. Low fuel supply
 2. Dc undervoltage
 3. Low oil pressure
 4. High engine temperature
- 7-39. At a maximum load of 1,000 amperes, the NC-10C can be operated continuously for no longer than what maximum amount of time?
1. 5 seconds
 2. 15 seconds
 3. 20 seconds
 4. 25 seconds
- 7-40. On the NC-10C, both the ac and dc power outputs are regulated by what type of regulator?
1. Transistorized
 2. Carbon pile
 3. Two-stage magnetic amplifier
 4. Single-stage magnetic amplifier
- 7-41. Which of the following units require(s) an external source of electrical power for operation?
1. MMG-1A
 2. NC-10C
 3. NC-2A
 4. NC-8A
- 7-42. The MMG-1A provides what type of output?
1. Ac and dc power for maintenance, calibration, and support for aircraft
 2. Compressed air for starting jet aircraft
 3. Hydraulic power for testing aircraft systems
 4. Compressed nitrogen for servicing aircraft pneumatic systems
- 7-43. Performance tests are performed on MEPPs to determine their ability to operate within prescribed perimeters under which of the following conditions?
1. Full-load only
 2. No-load only
 3. No-load and full-load
 4. Full-load and overload

- 7-44. "Detection and location of a malfunction by an orderly and systematic procedure" defines which of the following terms?
1. Testing
 2. Diagnosing
 3. Servicing
 4. Troubleshooting
- 7-45. The dummy load is designed to perform electrical load testing on MEPPs rated at which of the following outputs?
1. 24 Vdc or 120/240 Vac, three-phase, four-wire, 400-Hz
 2. 28 Vdc or 120/208 Vac, three-phase, four-wire, 400-Hz
 3. 24 Vac or 120/240 Vac, three-cycle, four-wire, 400-amp
 4. 28 Vdc or 120/240 Vac, three-phase, four-wire, 400-Hz
- 7-46. What source supplies the control power circuit for operating the cooling fans, lights, load control relays and contactors within the load bank?
1. Internal rechargeable battery
 2. External power cord requiring 115/230 Vac, 60 Hz
 3. Both 1 and 2 above
 4. Ac or dc input power, depending on the MEPP being tested
- 7-47. The control circuitry of a dummy load will trip if the ac input voltage exceeds 130 Vac, and it cannot be reset until the voltage falls below what maximum value?
1. 129 Vac
 2. 127 Vac
 3. 125 Vac
 4. 123 Vac
- 7-48. During DC common bus operation with the COMMON BUS SHOCK LOAD switch in the 5-MIN position, the load bank can handle what maximum number of amperes?
1. 1,000
 2. 2,000
 3. 3,000
 4. 4,000
- 7-49. When a MEPP has 0-35 Vdc jet start capabilities, it cannot be tested on the dummy load bank unless what other requirements are met?
1. The 0-35 Vdc is derived from an ac rectified, dc variable power source
 2. The 0-35 Vdc is derived from an ac driven inverter
 3. The 0-35 Vdc is derived from a magnetic amplifier
 4. An additional ac or dc voltage is supplied to the load bank for its control power circuitry
- 7-50. An ac load of up to 281.5 kVA (at any power factor between 1.0 and 0.47) can be applied to the MEPP when the AC LOAD PROGRAM SELECTOR switch on the dummy load bank is in what position?
1. ON
 2. CONTINUOUS
 3. 5-SEC
 4. 5-MIN
- 7-51. The dummy load's ac control circuitry will interrupt and be locked out if its input frequency is below what specification?
1. 370 Hz
 2. 380 Hz
 3. 385 Hz
 4. 390 Hz
- 7-52. When working on an energized circuit, which of the following precautions should be taken?
1. An assistant should be stationed near the main switch
 2. The worker should be insulated from ground
 3. An experienced worker should be chosen
 4. All of the above
- 7-53. When removing a capacitor from an electrical circuit, which of the following steps should you perform first?
1. Remove the positive terminal
 2. Remove the negative terminal
 3. Short-circuit the capacitor terminals
 4. Loosen any connections mechanically holding the capacitor in place

- 7-54. Which of the following is NOT a safety precaution when working around high voltage circuits?
1. Never use tools containing metal parts
 2. Always work with another person
 3. Rings and watches should only be removed when voltages exceed 200 volts
 4. Always discharge capacitors before handling them

- 7-55. What is the purpose of using warning signs when working on a high-voltage circuit?
1. To prevent personnel from coming into accidental contact with the high voltage
 2. To warn personnel of possible power outages
 3. To increase personnel safety awareness
 4. To notify DC central that there is work being performed

ASSIGNMENT 8

Textbook Assignment: "Hydraulic Systems and Equipment," chapter 8, pages 8-1 through 8-46, and "Pneumatics," chapter 9, pages 9-1 through 9-21.

- 8-1. To find a detailed discussion on the fundamentals of hydraulics and pneumatics and the operation of various fluid power systems components, you should refer to which of the following publications?
1. *Construction Mechanic Advanced*, NAVEDTRA 14050
 2. *Pneumatic Power*, NAVPERS 16192-D
 3. *Fluid Power*, NAVEDTRA 14105
 4. *Basic Machines*, NAVEDTRA 14037
- 8-2. "Pressure applied to an enclosed or confined fluid is transmitted equally in all directions without loss and acts with equal force on equal surfaces," describes which of the following laws?
1. Pascal's law
 2. Charles' law
 3. Newton's law
 4. Murphy's law
- 8-3. What is the applied pressure exerted on a 200-square-inch output piston if a 100-pound force is applied to a 50-square-inch input piston?
1. 400 psi
 2. 200 psi
 3. 2 psi
 4. 1 psi
- 8-4. How far must an input piston with a 2.5-square-inch surface area move to produce a 10-inch movement on an output piston with a 5-square-inch surface area?
1. 12.5 inches
 2. 20.0 inches
 3. 25.5 inches
 4. 50.0 inches
- 8-5. What component serves as a fluid supply in a typical fluid power system?
1. The pump
 2. The reservoir
 3. The relief valve
 4. The fluid supply lines
- 8-6. What component generates force in a hydraulic system?
1. An accumulator
 2. An actuating unit
 3. A pump
 4. A motor
- 8-7. Hydraulic pumps are normally rated in terms of volumetric output and what other property?
1. Temperature
 2. Size
 3. Location
 4. Pressure
- 8-8. The output volume of a fixed displacement pump can only be changed by performing what specific action?
1. Changing the speed of the pump
 2. Adding a pressure compensator
 3. Adding a relief valve
 4. Adding fluid to the reservoir
- 8-9. In figure 8-11 of your textbook, tooth 1 is in mesh with space 1 at the start of the first revolution (view A). Following three complete revolutions, what tooth will be meshing with space 1?
1. Tooth 2
 2. Tooth 3
 3. Tooth 4
 4. Tooth 5
- 8-10. When a vane pump is operating, the vanes are pushed against the housing wall by what force?
1. Spring tension
 2. Centrifugal force
 3. Hydraulic pressure
 4. Magnetism
- 8-11. Reciprocating pumps used in support equipment normally function on which of the following operating principles?
1. Balanced and unbalanced
 2. Constant volume and variable volume
 3. Closed-loop and open-loop
 4. Axial piston or hand pump

- 8-12. What type of pump is used on the B-2 maintenance platform?
1. Single-action hand pump
 2. Variable-displacement pump
 3. Rotary pump
 4. Double-action hand pump
- 8-13. In the fixed-displacement piston pump shown in figure 8-15 in your textbook, the volume output is determined by the angle between which of the following components?
1. The piston and the drive shaft
 2. The point of attachment and the universal link
 3. The universal link and the drive shaft
 4. The cylinder block and the drive shaft
- 8-14. An advantage of using a variable-displacement pump in a hydraulic system is the elimination of which of the following components?
1. Pressure regulator
 2. Relief valve
 3. Boost pump
 4. Heat exchanger
- 8-15. What is the primary function of a hydraulic filter?
1. The retention of insoluble contaminants from the hydraulic fluid
 2. The retention of soluble contaminants from the hydraulic fluid
 3. To remove chlorinated solvents from the hydraulic fluid
 4. To pass insoluble contaminants from the hydraulic fluid
- 8-16. The normal lower level of visibility for the naked eye is what total number of microns?
1. 10 microns
 2. 20 microns
 3. 30 microns
 4. 40 microns
- 8-17. The micronic-type filter element is made of what type of material?
1. A treated fiber clothe
 2. A treated cellulose paper
 3. A sintered bronze
 4. A wire mesh
- 8-18. Hydraulic filters should be changed at what interval?
1. Every 30 days
 2. Every 60 days
 3. Every 90 days
 4. As specified in applicable MIM and maintenance requirements cards (MRCs)
- 8-19. The most common metal filter elements used in hydraulic systems are of what types?
1. Porous metal and wire mesh
 2. Stainless steel and wire mesh
 3. Stainless steel and sintered bronze
 4. Sintered bronze and micronic
- 8-20. The bypass pressure-relief valve in a filter housing serves what purpose?
1. It allows the fluid to bypass the element in the event the element becomes clogged
 2. It allows the fluid to bypass the element when the system pressure falls below a safe filtering value
 3. It regulates the gallons per minute (gpm) of fluid passing into the main pump
 4. It provides an accumulator for pulsating fluid pressures
- 8-21. A contamination indicator in a hydraulic filter assembly operates on what principle?
1. The amount of fluid aeration on the output side of the filter
 2. The amount of back-pressure on the discharge side of the pump
 3. The difference between the input volume and output volume of the filter
 4. The differential pressure between the inlet and outlet ports of the filter
- 8-22. All aircraft hydraulic servicing units must be equipped with a final filter of what micron rating?
1. 3 microns
 2. 5 microns
 3. 10 microns
 4. 15 microns
- 8-23. Valves that regulate the flow of hydraulic fluid are known as what type of valves?
1. Regulator valves
 2. Flow control valves
 3. Directional control valves
 4. Pressure control valves

- 8-24. The most common pressure control valve is what type of valve?
1. A release valve
 2. A shuttle valve
 3. A relief valve
 4. A pressure regulator
- 8-25. In the relief valve shown in figure 8-28 in your textbook, which of the following events occurs during an excessive pressure surge?
1. Piston 1 opens the return to the reservoir
 2. Pressure in chamber 3 forces piston 1 to close the return to the reservoir
 3. Pilot valve 4 opens, reducing pressure in chamber 3
 4. Pressures in chambers 3 and 9 remain in hydraulic balance
- 8-26. Hydraulic systems with fixed displacement pumps require which of the following types of valves?
1. Flow divider valve
 2. Relief valve
 3. Counterbalance valve
 4. Pressure regulator valve
- 8-27. A check valve is an example of what type of valve?
1. A regulator valve
 2. A flow control valve
 3. A directional control valve
 4. A pressure control valve
- 8-28. What is the purpose of an accumulator in a hydraulic system?
1. To regulate the volume of the fluid
 2. To regulate the pressure of the fluid
 3. To store a volume of fluid under pressure
 4. To prevent fluid aeration
- 8-29. What device transforms fluid pressure into mechanical force?
1. An actuator
 2. A pump
 3. A valve
 4. An accumulator
- 8-30. Which of the following support equipment uses single-action actuators?
1. Hydraulic jacks
 2. AERO-47A1 weapons loader
 3. A/M27T-5 power supply
 4. A/S32A-32 spotting dolly
- 8-31. What is the main part of gauges used in support equipment?
1. The dial
 2. The Bourdon tube
 3. The face
 4. The cover glass
- 8-32. What is purpose of a gauge snubber?
1. To increase the pressure value of the gauge
 2. To decrease the pressure value of the gauge
 3. To protect the gauge from vibration
 4. To dampen out system pressure surges
- 8-33. The hydraulic motor most commonly used in hydraulic systems is of what type?
1. Axial piston
 2. Radial piston
 3. Gear-type
 4. Rotor-type
- 8-34. Which of the following components is NOT required for a hydraulic system to operate?
1. A pump
 2. An actuator
 3. A relief valve
 4. A reservoir
- IN ANSWERING QUESTIONS 8-35 THROUGH 8-37, REFER TO FIGURE 8-46 IN YOUR TEXT-BOOK.
- 8-35. With the selector valve in the position indicated, fluid is returned to the reservoir from what component(s)?
1. The selector valve via the power pump
 2. The power pump via the selector valve
 3. The top of the actuating cylinder
 4. The bottom of the actuating cylinder via the selector valve
- 8-36. The pressure regulator and the check valve perform which of the following functions?
1. They relieve the workload on the pump and make the system more durable, safe, and efficient
 2. They relieve the pressure in the system in case of a mechanical failure
 3. They enable the system to utilize a variable-volume pump
 4. They determine the direction of the flow of fluid from the actuating cylinder

- 8-37. What is the purpose of a hand pump?
1. It maintains system pressure between two predetermined limits
 2. It acts as an emergency power source
 3. It traps fluid to maintain pressure until a mechanism is actuated
 4. It provides a buffer to suppress hydraulic surges
- 8-38. A closed-center hydraulic system differs from an open-center hydraulic system in what way?
1. A closed-center system has fluid flowing under no pressure when its pump is idling
 2. A closed-center system has its selector valves arranged in parallel
 3. A closed-center system has a constant-volume pump
 4. A closed-center system has no need for a pressure regulator
- 8-39. Contamination is commonly introduced into a hydraulic system at which of the following points?
1. The refill point
 2. The breather opening
 3. The cylinder rod packing
 4. Each of the above
- 8-40. Good contamination control practices are described in all EXCEPT which of the following statements?
1. Do not open hydraulic systems except when absolutely necessary
 2. Do not operate hydraulic equipment unless the hydraulic filter lamp is illuminated
 3. Use extreme caution and only approved equipment when servicing hydraulic systems
 4. Do not use hydraulic fluid that has been left in an open can or drained from a hydraulic system
- 8-41. Fluid sampling points on support equipment must meet the general requirements listed in what NAVAIR publication?
1. 17-1-114
 2. 17-1-125
 3. 01-1A-17
 4. 01-1A-20
- 8-42. Which of the following hydraulic system decontamination methods requires use of a cleaning agent?
1. Purging
 2. Flushing
 3. Recirculation cleaning
 4. Electrostatic cleaning
- 8-43. Which of the following malfunctions generally causes sluggish or erratic operation of a hydraulic system?
1. A defective mechanical linkages
 2. A defective electrical linkages
 3. An external or internal leaks
 4. Insufficient fluid in the system
- 8-44. What is the key to a hydraulic system's dependability?
1. The proper setting of relief valves and gauges
 2. The replacement of identical components
 3. The attention given to the cleanliness of the repair facility
 4. A sound understanding of the system's operation
- 8-45. Before reassembling a hydraulic valve, you should lubricate the internal parts with what type of lubricant?
1. A thin coat of general-purpose oil
 2. A thin coat of high-temperature grease
 3. A clean lubricating oil
 4. The specified type of hydraulic fluid used in the system
- 8-46. What is the major difference between a gas system and a hydraulic system?
1. Gases are more stable
 2. Gases are highly compressible
 3. Gases are less stable
 4. Gases are less compressible
- 8-47. The term "dry," as applied to a gas, means that the gas has a moisture content of less than which of the following measurements?
1. 0.10 milligrams per liter
 2. 0.07 milligrams per liter
 3. 0.05 milligrams per liter
 4. 0.02 milligrams per liter

- 8-48. Which of the following statements best describes the walk-around bottle's cylinder?
1. 500 cubic-inch capacity at 3,000 psi working pressure
 2. 300 cubic-inch capacity at 5,000 psi working pressure
 3. 300 cubic-inch capacity at 3,000 psi working pressure
 4. 500 cubic-inch capacity at 5,000 psi working pressure
- 8-49. The bleed valve on the walk-around bottle serves what purpose?
1. It isolates the cylinder from the plumbing during storage
 2. It assists in recharging the nitrogen cylinder from an external source
 3. It bleeds pressure from the servicing hose
 4. It isolates the cylinder pressure gauge from the system while bleeding the regulator
- 8-50. Requirements for the remote inflator assembly are covered in what publication?
1. NAVAIR 19-17-35
 2. NAVAIR 19-25B-15
 3. NAVAIR 17-1-123
 4. NAVAIR 17-1-125
- 8-51. The service hose on the walk-around bottle should be bled before securing the regulator to prevent what action?
1. Rupturing the regulator diaphragm with back pressure from the charged component
 2. System pressures and contaminants from backing up into the regulator
 3. Rupturing the cylinder safety valve
 4. Rupturing the servicing hose when bleeding the regulator
- 8-52. What is the purpose of the A/M26U-4?
1. To provide a versatile source of filtered high-pressure compressed air
 2. To provide a storage container for gaseous oxygen used in breathing equipment
 3. To provide a storage container for liquid oxygen used in breathing equipment
 4. To provide a versatile source of nitrogen for servicing aircraft high-pressure systems
- 8-53. Which of the following components is NOT attached to the A/M26U-4 control panel?
1. The pneumatic motor and pump
 2. The gauges
 3. The purifier
 4. The hand brake
- 8-54. The A/M26U-4 contains what total number of green lever control valves?
1. One
 2. Two
 3. Three
 4. Four
- 8-55. On the A/M26U-4, the amount of pressure going to the pump motor is controlled by what component?
1. The recharge valve
 2. The manifold bypass valve
 3. The motor regulator
 4. The pump inlet valve
- 8-56. The filter assembly on the A/M26U-4 is of what type?
1. 3-micron cellulose paper element with a 50-psi bypass valve
 2. 5-micron microfilm element with a 50-psi bypass valve
 3. 10-micron cellulose paper element with a non-bypassing housing
 4. 15-micron cellulose paper element with a non-bypassing housing
- 8-57. On the A/M26U-4, what is the pump and motor output pressure to input drive pressure ratio?
1. 10:1
 2. 20:1
 3. 30:1
 4. 40:1
- 8-58. When recharging the A/M26U-4, what device prevents the reverse flow of nitrogen from the recharge connection?
1. A check valve
 2. A flow diverter
 3. A counterbalance valve
 4. A bypass valve

- 8-59. When more than one control lever valve is opened at the same time on the A/M26U-4, what action results?
1. The combined pressure from the opened cylinders exceeds the relief valve setting
 2. The bypass valve automatically dumps the pressure in the cylinders
 3. The pressure equalizes between the opened cylinders
 4. The excess pressure ruptures the regulator's disc
- 8-60. Which of the following conditions is the most common cause for failure of the pressure regulator on the A/M26U-4?
1. A defective relief valve
 2. A ruptured diaphragm
 3. Contamination
 4. A stripped adjusting knob
- 8-61. The purifier on the A/M26U-4 should be changed how often?
1. Every 30 days
 2. Every 60 days
 3. After depletion of 12 cylinders
 4. As specified in the periodic maintenance requirements cards
- 8-62. The motor and pump assembly on the A/M26U-4 does not operate. Which of the following conditions can cause this malfunction?
1. A leaking pressure regulator
 2. An open or defective manifold bypass valve
 3. An improperly positioned motor inlet selector valve
 4. A clogged purifier
- 8-63. The manifold bypass valve on the A/M26U-4 should be opened during which of the following conditions?
1. When operating the pump using nitrogen drive
 2. When recharging the cylinders
 3. When operating the pump using air drive
 4. Both 2 and 3 above
- 8-64. Compressed air cylinders should be painted what color?
1. Black
 2. White
 3. Orange
 4. Yellow

ASSIGNMENT 9

Textbook Assignment: "Liquid and Gaseous Oxygen Systems," chapter 10, pages 10-1 through 10-39, and "Mobile Air-Conditioners," chapter 11, pages 11-1 through 11-36.

- 9-1. Which of the following traits are characteristics of oxygen?
1. Weightless, colorless, and tasteless
 2. Tasteless, volume less, and odorless
 3. Tasteless, colorless, and odorless
 4. Volume less, weightless, and colorless
- 9-2. Which of the following statements concerning the indicating gauges of the TMU-70/M LOX trailer is true?
1. The storage tank liquid level gauge is calibrated in gallons
 2. The transfer tank liquid level gauge is calibrated in percent full
 3. The converter full indicator monitors the converter vent line temperature and indicates GAS during transfer to the converter and LIQUID when the converter is full
 4. All of the above
- 9-3. Which of the following valves on the TMU-70/M controls the flow of oxygen gas vapors from the transfer tank to the vapor space of the storage tank?
1. Fill-drain line shutoff valve
 2. Converter vent line shutoff valve
 3. Transfer tank vent shutoff valve
 4. Transfer tank fill line shutoff valve
- 9-4. What is the maximum pressure permitted in the storage tank of the TMU-70/M when you fill it from central supply tanks?
1. 90 psig
 2. 50 psig
 3. 45 psig
 4. 30 psig
- 9-5. Under normal conditions and with 30 psig of transfer pressure, the storage tank should be filled within what average period of time?
1. 5 to 8 minutes
 2. 5 to 10 minutes
 3. 4 to 8 minutes
 4. 3 to 6 minutes
- 9-6. When emptying the liquid oxygen from the transfer tank to the storage tank, which of the following statements concerning the positioning of the transfer tank fill-line shutoff valve and the transfer tank pressure buildup valve is true?
1. Both valves should be closed
 2. The transfer tank fill-line shutoff valve should be closed; the transfer tank pressure buildup valve should be adjusted to maintain required pressure
 3. The transfer tank fill-line shutoff valve should be open; the transfer tank pressure buildup valve should be opened if necessary
 4. The transfer tank pressure buildup valve should be closed; the transfer tank fill-line shutoff valve should be adjusted to maintain required pressure
- 9-7. A blown rupture disc on the TMU-70/M LOX trailer is indicated by which of the following conditions?
1. Failure to build up pressure
 2. Visible vapors from the vent line
 3. Frost formation
 4. Each of the above
- 9-8. What test is performed on the LOX trailer to locate plumbing leaks?
1. Evaporation loss rate
 2. Bubble
 3. Sniff
 4. Vacuum
- 9-9. What method should you use to divert free-flowing LOX away from combustibles?
1. A strong stream of water
 2. Blasts of compressed air
 3. Barrier material
 4. A clean swab

- 9-10. Clothing splashed by LOX should be aired for at least how long?
1. 15 min
 2. 30 min
 3. 45 min
 4. 60 min
- 9-11. An odor test should be performed on a LOX trailer at which of the following times?
1. After servicing a converter
 2. After the vent valve has been left open
 3. Whenever contamination is suspected
 4. Whenever the transfer tank is filled
- 9-12. When repeated LOX washing fails to decontaminate a LOX trailer, you should take what action?
1. Turn the unit into salvage
 2. Flush the system with a known good supply of LOX
 3. Let the unit stand for 24 hours and retest it
 4. Have the unit purged
- 9-13. Gaseous cylinders may have a safety device installed in which of the following locations?
1. The valve only
 2. The bottom only
 3. The shoulder only
 4. The valve, the bottom, and the shoulder
- 9-14. What is the primary purpose of the A/U26U-1?
1. To provide a mobile source of compressed air for servicing pneumatic systems
 2. To provide a mobile source of nitrogen for servicing pneumatic systems
 3. To provide a mobile source of oxygen for servicing aircraft systems
 4. To provide a source of compressed air for operating pneumatic tools and equipment
- 9-15. The A/U26U-1 trailer houses what total number of cylinders?
1. Six
 2. Five
 3. Three
 4. Four
- 9-16. The nitrogen cylinders on the A/U26U-1 should be filled to what maximum pressure?
1. 5,000 psi
 2. 3,500 psi
 3. 2,400 psi
 4. 1,800 psi
- 9-17. The nitrogen module on the A/U26U-1 houses which of the following components?
1. The boost pump
 2. The high-pressure relief valve
 3. The bypass valve
 4. The boost pump drive valve
- 9-18. During operation, the normally closed pilot valve on the A/U26U-1 closes when the pressure at the boost pump inlet falls below what minimum pressure?
1. 200 psi
 2. 250 psi
 3. 400 psi
 4. 500 psi
- 9-19. On the A/U26U-1, the pressure upstream of the pressure regulator is vented to the atmosphere by what component?
1. The nitrogen supply valve
 2. The low-pressure rupture disc
 3. The oxygen vent valve
 4. The selector valve
- 9-20. To relieve excessive pressure, the low-pressure servicing adapter on the A/U26U-1 contains a burst disc that is designed to rupture at what specific pressure?
1. 400 psi
 2. 600 psi
 3. 800 psi
 4. 1,000 psi
- 9-21. When using the pressure equalization method to service an aircraft system, the selector valve should be placed in what position?
1. OFF
 2. BYPASS
 3. BOOST
 4. VENT
- 9-22. Ship service air used to drive the boost pump on the A/U26U-1 should have what minimum pressure?
1. 200 psi
 2. 150 psi
 3. 120 psi
 4. 90 psi

- 9-23. Maintenance on the A/U26U-1 should be performed in accordance with which of the following publications?
1. NAVAIR 19-25D-31
 2. NAVAIR 19-25D-26
 3. NAVAIR 19-25B-15
 4. NAVAIR 19-25A-38
- 9-24. All hoses and tubes on the A/U26U-1 must be suitable for oxygen use as specified in which of the following manuals?
1. NAVAIR 17-1-125
 2. NAVAIR 16-1-540
 3. NAVAIR 15-01-500
 4. NAVAIR 01-1A-20
- 9-25. An oxygen cylinder must be decontaminated by heat-vacuum treatment when the pressure within the cylinder falls below what minimum pressure?
1. 90 psig
 2. 50 psig
 3. 25 psig
 4. 15 psig
- 9-26. An AS is normally concerned with air-conditioning systems that provide which of the following functions?
1. Cooling and dehumidifying
 2. Cooling and ventilating
 3. Cooling, heating, and ventilating
 4. Cooling, dehumidifying, and heating
- 9-27. Which of the following statements concerning heat is true?
1. It cannot be seen only
 2. It cannot be created only
 3. It cannot be destroyed only
 4. It cannot be seen, created, or destroyed
- 9-28. Heat is a form of which of the following terms?
1. Energy
 2. Radiation
 3. Convection
 4. Motion
- 9-29. What are the two methods by which heat is measured?
1. Quantity and conduction
 2. Intensity and radiation
 3. Convection and conduction
 4. Intensity and quantity
- 9-30. A British thermal unit (Btu) is the quantity of heat required to raise the temperature of 1 pound of pure water 1-degree Fahrenheit. What is the starting temperature of the water when figuring the Btu?
1. 38.90°F
 2. 32.10°F
 3. 39.10°F
 4. 98.6 °F
- 9-31. Which of the following types of heat is heat that is added to, or subtracted from, a substance and changes its temperature but not its physical state?
1. Sensible heat
 2. Latent heat
 3. Total heat
 4. Specific heat
- 9-32. As pressure on a liquid increases, what happens to the boiling point?
1. It remains the same
 2. It decreases
 3. It increases
 4. It increases, and then drops off sharply
- 9-33. What law states, "The volume of a gas varies inversely to the pressure, provided the temperature remains the same?"
1. Presley's law
 2. Boyle's law
 3. Charles' law
 4. Johnson's law
- 9-34. Which of the following statements defines Charles' law?
1. "At a constant pressure, the volume of a compressed gas varies directly to the absolute temperature; at a constant volume, pressure varies directly to the absolute temperature"
 2. "The volume of a gas varies inversely to the pressures, provided the temperature remains constant"
 3. "The total pressure of a confined mixture of gases is the sum of the pressure of each of the gases in the mixture"
 4. "The volume of a gas varies proportionally to the pressures, provided the temperature remains constant"

- 9-35. The process by which a vapor changes state to a liquid when heat is removed from the vapor is known by what term?
1. Compression
 2. Condensation
 3. Conduction
 4. Convection
- 9-36. The act of increasing the pressure and temperature of a substance by decreasing its volume is known by what term?
1. Compression
 2. Condensation
 3. Conduction
 4. Convection
- 9-37. Which of the following is NOT an advantage of R-12 refrigerant?
1. Its vapor is nontoxic
 2. At the low pressure point of its cycle, it operates at pressures slightly above atmospheric pressure
 3. It operates on high system pressures, allowing for heavy weight construction
 4. It is nonflammable, non-explosive, and non-corrosive
- 9-38. Water combines with R-12 and R-22 to form which of the following acids?
1. Sulfuric
 2. Nitric
 3. Hydrochloric
 4. Chromic
- 9-39. The refrigerant changes from a low-pressure gas to a high-pressure gas as it passes through what component?
1. The condenser
 2. The metering device
 3. The compressor
 4. The evaporator
- 9-40. What unit of the air-conditioner removes and dissipates latent heat from the compressed gas?
1. The evaporator
 2. The compressor
 3. The condenser
 4. The receiver
- 9-41. Which of the following functions is NOT a purpose of the receiver?
1. To store refrigerant during off-peak operation
 2. To accumulate the reserve liquid refrigerant
 3. To permit the entrance of gaseous refrigerant into the liquid line
 4. To permit pumping down the system
- 9-42. The function of the refrigerant metering device, such as the thermostatic expansion valve, is to perform which of the following functions?
1. To indicate the quantity of refrigerant used
 2. To indicate the quantity of refrigerant remaining
 3. To control the quantity of gas refrigerant flow out of the condenser
 4. To control the quantity of liquid refrigerant flow into the evaporator
- 9-43. What causes the coils of the evaporator to become cold?
1. Air being directed over them
 2. Heat being dissipated from the coils to the surrounding atmosphere
 3. The refrigerant absorbing heat from the coils as it changes from a liquid to a gas
 4. The refrigerant absorbing heat from the coils as it changes from a gas to a liquid
- 9-44. A convoluted phosphorous bronze tube may be used in place of a rigid copper tube for what purpose?
1. Radiating heat
 2. Absorbing shock
 3. Restricting refrigerant flow
 4. Allowing increased refrigerant flow
- 9-45. Some of the operating controls in an air-conditioning system are manually controlled by the operator. Others are automatic and operate in response to what action?
1. Remote control
 2. Constant operating conditions
 3. Changing the location of the unit
 4. Changes in temperature or pressure
- 9-46. What component is usually threaded into the receiver tank, and is designed to relieve pressure in the event of fire?
1. A pressure-relief valve
 2. A fusible plug
 3. A double-action hand-pump
 4. A high-pressure cut-out

- 9-47. When R-22 comes in contact with a flame, it turns into what deadly nerve gas?
1. Phosphoric acid
 2. Cyanide
 3. Hydrogen sulfide
 4. Phosgene
- 9-48. Which of the following statements concerning the A/M32C-17 is NOT correct?
1. It is self-propelled
 2. It provides 150 pounds per minute of refrigerated air
 3. It delivers 75 pounds per minute of air at static pressures up to 4 psig at the end of the delivery hose
 4. Its total power for the air conditioner is supplied by a diesel engine
- 9-49. When the A/M32C-17 is operating in the cooling mode, what is the maximum relative humidity of the delivered air?
1. 85%
 2. 80%
 3. 60%
 4. 40%
- 9-50. The A/M32C-17 has what total number of modes of operation?
1. One
 2. Two
 3. Three
 4. Four
- 9-51. The drier-filter of the A/M32C-17 is located in what position?
1. Between the receiver inlet and the outlet valves
 2. Between the solenoid valve and the expansion valve
 3. Between the heat exchanger and the expansion valve
 4. Between the heat exchanger and the receiver outlet valve
- 9-52. What component of the A/M32C-17 permits cold liquid refrigerant to be added to the hot liquid to lower the temperature of the hot gas?
1. Hot gas bypass valve
 2. Expansion valve
 3. Compressor suction valve
 4. Quench valve
- 9-53. When the A/M32C-17 is ventilating, the blower is driven by what device(s)?
1. A belt
 2. Gears
 3. A hydraulic motor
 4. An electric motor
- 9-54. For all of the evaporator solenoids to close on the A/M32C-17, the selector switch must be in what position?
1. Dehumidify
 2. Pump down
 3. Cool
 4. Air condition
- 9-55. To sense refrigerant head pressure on the A/M32C-17, a capillary tube in the refrigerant line is connected to which of the following components?
1. The pressure control valve
 2. The pressure transducer
 3. The receiver outlet valve
 4. The suction valve
- 9-56. The hose in the center of the manifold test set should be connected to which of the following items?
1. A vacuum pump only
 2. A recovery system only
 3. A refrigerant cylinder only
 4. A vacuum pump, recovery system, and refrigerant cylinder
- 9-57. After pump down, the system should be allowed to stabilize at what maximum pressure?
1. 1 psi
 2. 5 psi
 3. 3 psi
 4. 10 psi
- 9-58. The first step in the removal of any refrigeration system component is to perform what function?
1. To pump the system down
 2. To evacuate the system
 3. To unload the compressor
 4. To charge the system
- 9-59. A leak from which of the following components is the most difficult to detect?
1. The drier strainer
 2. The condenser
 3. The receiver
 4. The evaporator

- 9-60. When the flame of the halide torch remains white in the presence of a R-22 leak, you should take which of the following actions first?
1. Clean the exploring tube
 2. Replace the reactor plate
 3. Replace the burner
 4. Dispose of the unit
- 9-61. When charging a system with liquid refrigerant, you should connect the high-pressure hose of the manifold test set to which of the following items?
1. The receiver inlet valve
 2. The compressor suction valve
 3. The compressor head valve
 4. The expansion valve outlet service connection
- 9-62. What is/are the purpose(s) of the ST-1000/ST-100A unit?
1. To recover refrigerant only
 2. To filter refrigerant only
 3. To recover and filter refrigerant
 4. To determine the moisture content of the refrigerant
- 9-63. To ensure that refrigerant lines and containers are maintained properly, which of the following precautions must be observed?
1. Cylinders must not be filled above 80% capacity
 2. Refrigerant containers, whether lines or drums, must not be heated
 3. Only vapor, never liquid, is to be injected into the suction side of the compressor
 4. All of the above

ASSIGNMENT 10

Textbook Assignment: "Gas Turbine Compressors," chapter 12, pages 12-1 through 12-39, and "Shipboard Flight deck Equipment," chapter 13, pages 13-1 through 13-23.

- 10-1. What are the two basic types of gas turbine engines?
1. Centrifugal-flow and axial-flow
 2. Centrifugal-flow and radial-flow
 3. Centrifugal-flow and reverse-flow
 4. Axial-flow and reverse-flow
- 10-2. What gas turbine engine is most commonly used in support equipment?
1. Reverse-flow
 2. Centrifugal-flow
 3. Axial-flow
 4. Turbojet
- 10-3. The greatest difference between axial-flow and centrifugal-flow gas turbine engines is in what section of the engine?
1. The exhaust section
 2. The turbine section
 3. The starter section
 4. The compressor section
- 10-4. The gas turbine engine has what total number of major sections?
1. One
 2. Two
 3. Three
 4. Four
- 10-5. In reference to the air reaching the compressor of a gas turbine engine, which of the following statements is correct?
1. It must be available in the same quantity required to operate reciprocating engines
 2. It must be free from turbulence
 3. It must be heated to a high temperature
 4. It must be under extremely high pressure
- 10-6. Air used in operating pneumatic equipment is taken from what part of the gas turbine compressor (GTC)?
1. The turbine section
 2. The combustion chamber
 3. The compressor section
 4. The accessory section
- 10-7. What area of the GTC provides drive for the entire unit?
1. The combustion chamber
 2. The accessory drive
 3. The compressor
 4. The turbine
- 10-8. On the GTC, the compressed air that is developed for external use is obtained as bleed air from what part of the engine?
1. The turbine exhaust system
 2. The turbine plenum chamber
 3. The first-stage compressor
 4. The flame tube
- 10-9. What component or system of the GTC-85 automatically maintains a constant turbine rpm?
1. The fuel spray nozzle
 2. The turbine plenum chamber
 3. The fuel and control air system
 4. The flame tube inlet valve
- 10-10. What component of the GTC-85 controls turbine speed during starting and acceleration?
1. The pneumatic governor
 2. The mechanical governor
 3. The load thermostat
 4. The load valve
- 10-11. What component of the GTC-85 controls the rate of acceleration from 0 to 35 percent governed speed?
1. The air shutoff valve
 2. The mechanical governor
 3. The acceleration stabilizer
 4. The load valve
- 10-12. On the GTC-85, where is the load control thermostat located?
1. On the control panel
 2. In the engine tail pipe
 3. Next to the fuel pump and control unit
 4. Behind the unloading air shutoff valve

- 10-13. On the GTC-85, after the oil has lubricated the gears, shafts, and bearings, it is routed through the common sump directly to what location?
1. The scavenge pump
 2. The oil tank
 3. The oil cooler
 4. The pressure pump
- 10-14. The purpose of the bypass line around the oil cooler, as illustrated in figure 12-7 of your textbook, is to perform what specific operation?
1. To prevent loss of pressure in the event that the cooler becomes clogged
 2. To supplement the oil flow through the cooler
 3. To prevent cooling of the oil until the oil temperature exceeds operating temperature
 4. To act as a feedback line to further cool any oil that may still be too hot after leaving the cooler
- 10-15. What is the purpose of the 35-percent switch on the GTC-85?
1. To de-energize the starter
 2. To act as a safety device
 3. To permit the use of bleed air
 4. To start the unit
- 10-16. What is the purpose of the 110-percent switch on the GTC-85?
1. To actuate a governor that reduces engine rpm to a safe level
 2. To de-energize the ignition unit if the engine rpm exceeds 110 percent
 3. To complete the circuit to the load
 4. To shut off the fuel to the engine if the engine accelerates past 110 percent
- 10-17. On the GTC-85, combustion is initiated at approximately what rpm?
1. 5,000 rpm
 2. 15,000 rpm
 3. 35,000 rpm
 4. 42,000 rpm
- 10-18. Engine rpm and turbine temperature are determined by controlling which of the following items?
1. Inlet airflow
 2. Fuel flow
 3. Oil pressure
 4. Exhaust airflow
- 10-19. On the GTC-85, if during the start cycle the turbine temperature exceeds the specified value, what action takes place to protect the unit?
1. The acceleration control thermostat bypasses fuel, thereby reducing pressure at the fuel nozzle
 2. The fuel shutoff solenoid valve actuates, cutting off fuel to the engine
 3. The ignition system de-energizes, cutting off the spark at the igniter plug
 4. The starter motor relay de-energizes, preventing the engine from reaching the 35 percent point
- 10-20. The governor corrects an underspeed condition of the turbine by performing what function?
1. By increasing fuel bypass, thereby decreasing the pressure applied to the fuel nozzle
 2. By increasing fuel bypass, thereby increasing the pressure applied to the fuel nozzle
 3. By restricting fuel bypass, thereby increasing the pressure applied to the fuel nozzle
 4. By restricting fuel bypass, thereby decreasing the pressure applied to the fuel nozzle
- 10-21. The purpose of the GTCP-100 gas turbine compressor is to provide what type of service?
1. Provide compressed air for power tools
 2. Provide mechanical and electrical power for air turbine starters
 3. Provide mechanical and pneumatic power for hydraulic pumps and air turbine motors
 4. Provide mechanical and hydraulic power to test aircraft systems
- 10-22. On the GTCP-100, compression of outside air is done by what total number of stages in the compressor section?
1. One
 2. Two
 3. Three
 4. Four
- 10-23. The fuel shutoff and drain solenoid valve of the GTCP-100 is mounted on what assembly?
1. Compressor
 2. Turbine
 3. Accessory
 4. Oil cooler

- 10-24. What total number of igniter plugs is used on the GTCP-100?
1. One
 2. Three
 3. Five
 4. Six
- 10-25. The second-stage impellers receive compressed air from the first-stage impellers through which of the following components?
1. The compressor plenum
 2. The cross-fire tubes
 3. The crossover ducts
 4. The diffuser housing
- 10-26. On the GTCP-100, what component(s) meter(s) fuel flow during starting?
1. The pneumatic governor (fuel scheduling valve)
 2. The fuel atomizers
 3. The mechanical governor
 4. The flow divider valve
- 10-27. FULL fuel flow to the atomizers should begin at what specific pressure?
1. 75 psig
 2. 100 psig
 3. 125 psig
 4. 150 psig
- 10-28. What component controls butterfly valve modulation in the modulating and shutoff valve?
1. The load control thermostat
 2. The pneumatic shutoff valve
 3. The acceleration and over-temperature thermostat
 4. The variable pressure regulator
- 10-29. The lubrication system of the GTCP-100 uses what total numbers of scavenge pumps?
1. One
 2. Two
 3. Three
 4. Four
- 10-30. On the GTCP-100, pressurized oil operates which of the following components?
1. The starter motor clutch
 2. The hydraulic servo assembly
 3. The cooling fan
 4. Each of the above
- 10-31. On the GTCP-100, the contacts of the oil pressure switch energize the components listed below in what sequence?
1. Fuel shutoff and drain valve, start counter, and ignition unit
 2. Fuel shutoff and drain valve, ignition unit, and start counter
 3. Ignition unit, fuel shutoff and drain valve, and start counter
 4. Start counter and ignition unit, then fuel shutoff and drain valve
- 10-32. The igniter of the GTCP-100 stops firing at what percent of governed engine speed?
1. 10%
 2. 20%
 3. 35%
 4. 95%
- 10-33. When the starter relay of a GTC clicks but the starter is silent, which of the following components is likely defective?
1. The current limiter relay coil
 2. The turbine inlet door switch
 3. The starter clutch
 4. The 95 percent switch
- 10-34. If a flame is observed at the exhaust when you start a gas turbine engine, which of the following components may be suspect?
1. The oil pressure-sequencing switch
 2. The fuel filter
 3. The auxiliary fuel solenoid
 4. The ignition unit
- 10-35. Which of the following conditions likely exists if a gas turbine engine lights off but "hangs" as the turbine discharge temperature approaches the setting of the acceleration and over-temperature thermostat?
1. The engine is burning the puddles of fuel in the combustion chamber only
 2. The engine is unable to reach idle speed because of fouled ignition plugs only
 3. Both 1 and 2 above
 4. The engine is requiring more than the normal power from the turbine

- 10-36. During an unscheduled shutdown of a gas turbine engine, a fog of unburned fuel is being discharged through the turbine exhaust. This can happen as a result of what malfunction?
1. The electrical controls being de-energized
 2. The fuel solenoid valve being closed
 3. The 110-percent switch being set too low
 4. The combustion chamber flame having gone out
- 10-37. Speed droop is controlled by which of the following components when the bleed load switch of a GTC is energized?
1. Boost pump
 2. Fuel control mechanical governor
 3. Acceleration control thermostat
 4. Fuel filter sensor
- 10-38. Which of the following statements relative to the UPUA4-1 engine analyzer is INCORRECT?
1. A battery is furnished with the analyzer to provide the electrical power necessary for the proper test functions when the analyzer is used with an engine on a test stand
 2. When installed in a service installation, the battery of the service installation provides the electrical power necessary for the proper test functions
 3. The analyzer is provided with a speed conversion chart that converts tachometer rpm indications to actual engine rpm for different engines that can be tested
 4. The analyzer contains a very sensitive pressure gauge in the lid compartment
- 10-39. What connection(s) on the engine analyzer is/are used to measure engine speed?
1. J5
 2. K17 and K18
 3. J4
 4. K22 and K23
- 10-40. What switch on the engine analyzer is used for monitoring the start circuit?
1. S1
 2. S2
 3. S4
 4. S7
- 10-41. Which of the following areas around an operating gas turbine engine mounted in the UTTS-1-7 must be avoided?
1. The compressor air inlet
 2. The turbine exhaust
 3. The turbine's plane of rotation
 4. All of the above
- 10-42. Scheduled maintenance on aircraft crash and fire-fighting equipment is generally performed during in-port periods for which of the following reasons?
1. To provide more time for scheduled maintenance while underway
 2. Because some maintenance checks cannot be performed while underway
 3. Because some of the required replacement parts might not be readily available at sea
 4. Because aircraft crash and fire-fighting equipment must be fully operational during flight operations
- 10-43. What is the primary purpose of the amphibious assault ship crash crane?
1. To provide support for all flight deck cargo handling operations
 2. To assist the deck crew when they are moving the boarding ladder
 3. To move crashed or damaged aircraft from the landing or launch areas
 4. To offload SE to the beach
- 10-44. The AACC can lift what maximum number of pounds?
1. 40,000
 2. 50,000
 3. 60,000
 4. 70,000
- 10-45. What type of wheel braking system is used on the AACC?
1. A hydraulic disc-type
 2. A hydraulic drum-type
 3. A hydraulic expander tube
 4. An electric regenerative motor
- 10-46. What is the maximum vehicle speed of the AACC during pendant operation?
1. 1 mph
 2. 2 mph
 3. 3 mph
 4. 5 mph

- 10-47. The differential of the AACC is driven by which of the following components?
1. An automatic transmission and a non-slip differential
 2. A hydrostatic transmission
 3. Electric motors
 4. Hydraulic motors
- 10-48. Aircraft lifting slings are classified under what types of construction?
1. Specific or universal usage
 2. Fabric or metal strap
 3. Chain, wire rope, fabric, and structural metal
 4. Wire rope, chain, or rigid frame
- 10-49. Aircraft slings should be stored, inspected, and repaired in accordance with which of the following manuals?
1. NAVAIR 00-80T-96
 2. NAVAIR 01-1A-17
 3. NAVAIR 01-1A-20
 4. NAVAIR 17-1-114
- 10-50. A cable sling should be disassembled, inspected by NDI, and requalified how often?
1. Annually, or upon failure to pass a preinstallation inspection
 2. Semiannually, or upon failure to pass a preinstallation inspection
 3. Every 13-week inspection or upon failure to pass a preinstallation inspection
 4. Only if a major component fails a proof-load testing
- 10-51. What is the capacity of the two fire-fighting storage tanks onboard the A/S32P-25?
1. 75 gallons of AFFF solution and 400 pounds of PKP
 2. 100 gallons of AFFF and 375 pounds of PKP
 3. 55 gallons of AFFF solution and three 20 lb bottles of HALON 1211
 4. 40 gallons of AFFF and two 50 lb bottles of HALON 1211
- 10-52. On the A/S32P-25, what type of hydraulic pump is used in the propulsion system?
1. A variable displacement pump
 2. A high-pressure, full-flow pump
 3. A low-pressure, full-flow pump
 4. A rotary pump
- 10-53. On the A/S32P-25, the water is prevented from freezing by what components?
1. Five, 24 Vdc heating strips wrapped around various valves and plumbing, controlled by a thermostat and the engine alternator
 2. Heating elements submerged within the water tank and powered by a 440 Vac external power source
 3. Two heating strips wrapped around various valves and plumbing controlled by a thermostat and powered by a 440 Vac external power source
 4. Five heating blankets submerged within the light water tank powered by the engine alternator
- 10-54. Aircraft lifting slings are classified under what types of construction?
1. Specific or universal usage
 2. Fabric or metal strap
 3. Chain, wire rope, fabric, and structural metal
 4. Wire rope, chain, or rigid frame
- 10-55. On a forklift, what means or device is used to raise the load?
1. An electric motor
 2. A hydraulic cylinder
 3. A pneumatic cylinder
 4. An accumulator
- 10-56. The hydraulic system of the forklift is known by what name?
1. Reverse-flow
 2. Double-acting
 3. Closed-center
 4. Open-center
- 10-57. On a forklift, what device prevents the load from lowering too fast?
1. A counterbalance valve
 2. An orifice check valve
 3. A flow divider
 4. A flow equalizer
- 10-58. The flight deck scrubber is propelled by what means?
1. A three-speed manual transmission
 2. A two-speed automatic transmission
 3. Two hydraulic drive motors
 4. An electric motor

10-59. The direction of the flight deck scrubber is controlled by what device?

1. A directional control pedal
2. A directional control switch
3. A selector lever
4. A gearshift

10-60. The hand-held, high-pressure sprayer of the flight deck scrubber can dispense cleaning solution at a rate of 4 gal/min at pressures up to how many psig?

1. 500 psig
2. 600 psig
3. 700 psig
4. 800 psig