

**SUBCOURSE  
SS05235**

**EDITION  
5**

---

# **OPERATION OF AUTOMATIC PRINT PROCESSORS**

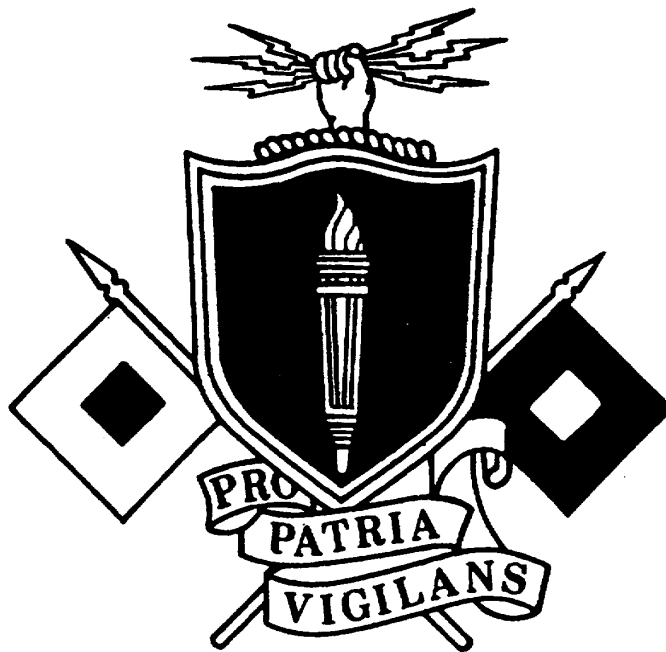

**THE ARMY INSTITUTE FOR PROFESSIONAL DEVELOPMENT  
ARMY CORRESPONDENCE COURSE PROGRAM**

**A  
I  
P  
D**

**READINESS /  
PROFESSIONALISM**



**THRU  
GROWTH**

US ARMY STILL PHOTOGRAPHIC SPECIALIST  
MOS 84B, SKILL LEVEL 1 COURSE

AUTHORSHIP RESPONSIBILITY

SP5 GERALD SMITH  
3420 TCHTG Sciences Branch  
Lowry AFB, CO  
AUTOVON: 926-2521  
COMMERCIAL: (303) 370-2521

OPERATION OF AUTOMATIC  
PRINT PROCESSORS

SUBCOURSE NO. SS0523-5

US Army Signal School  
Fort Gordon, Georgia

Four Credit Hours

GENERAL

The Operation of Automatic Print Processors subcourse, part of the Still Photographic Specialist MOS 84B Skill Level 1 Course, is designed to teach the knowledge necessary for performing tasks related to automatic print processors. Information is provided which is not currently available through resident training in Advanced Individual Training for MOS 84B. This subcourse is also intended to aid the Illustrator MOS 81E merge into MOS 84B at Skill Level 3. The subcourse is presented in three lessons, each lesson corresponding to a terminal objective as indicated below.

Lesson 1: PREPARE AN AUTOMATIC PRINT PROCESSOR

- TASK:** Describe the components, purpose and operation of the automatic print processor.
- CONDITIONS:** Given information about the components' purpose, and operation of various models of automatic print processors.
- STANDARDS:** Demonstrate competency of the task skills and knowledge by responding to the multiple-choice test covering components, purpose, and operation of automatic print processors.

(This objective supports STP TASK 113-578-3046, Prepare an Automatic Print Processor for Operation.)

## Lesson 2: OPERATE AN AUTOMATIC PRINT PROCESSOR

**TASK:** Describe the methods of operation, maintenance of chemicals, and importance of silver recovery in using automatic print processors.

**CONDITIONS:** Given information on the operation of the Kodak Royalprint Processor Model 417, the chemical requirements of the processor, and the importance of silver recovery.

**STANDARDS:** Demonstrate competency of the task skills and knowledge by responding to the multiple-choice test covering operation of automatic print processor.

(This task supports STP 113-578-3047, Operate Automatic Print Processor.)

## Lesson 3: PROCESS PAPER IN AN AUTOMATIC PRINT PROCESSOR

**TASK:** Describe the conventional, stabilization, and activation processes.

**CONDITIONS:** Given information on the methods of processing photographic paper using a Kodak Royalprint Processor.

**STANDARDS:** Demonstrate competency of the task skills and knowledge by responding to the multiple-choice test covering methods of processing paper in an automatic print processor.

(This objective supports STP Task 113-578-3047, Operate Automatic Print Processor.)

## TABLE OF CONTENTS

Section	Page
TITLE PAGE .....	i
TABLE OF CONTENTS.....	iii
INTRODUCTION TO AUTOMATIC PRINT PROCESSORS.....	vi
Lesson 1: PREPARE AN AUTOMATIC PRINT PROCESSOR.....	1
Learning Event 1: Define the Capabilities of the Automatic Print Processor.....	1
Learning Event 2: Describe the Operation of the Automatic Print Processor .....	5
Learning Event 3: Identify the Major Components of an Automatic Print Processor.....	7
Practice Exercise .....	14
Answers to Practice Exercise.....	15
Lesson 2: OPERATE AN AUTOMATIC PRINT PROCESSOR.....	16
Learning Event 1: Describe the Operation and Controls of the Kodak Royalprint Processor.....	16
Learning Event 2: Describe the Start Up Procedure for the Kodak Royalprint Processor.....	18
Learning Event 3: Describe the Processing Procedure Using the Kodak Royalprint Processor.....	20
Learning Event 4: Describe the Shutdown Procedure for the Kodak Royalprint Processor.....	23
Learning Event 5: Describe the Procedure for Changing Chemicals in the Kodak Royalprint Processor.....	23
Learning Event 6: Identity the Importance of Silver Recovery.....	24

Section	Page
Practice Exercise.....	26
Answers to Practice Exercise.....	27
Lesson 3: PROCESS PAPER IN AN AUTOMATIC PRINT PROCESSOR.....	28
Learning Event 1: Describe the Conventional Process of Print Processing.....	28
Learning Event 2: Describe the Stabilization Process.....	30
Learning Event 3: Describe the Activation - Conventional Processing.....	31
Practice Exercise.....	34
Answers to Practice Exercise.....	35

**\*\*\* IMPORTANT NOTICE \*\*\***

**THE PASSING SCORE FOR ALL ACCP MATERIAL IS NOW 70%.**

**PLEASE DISREGARD ALL REFERENCES TO THE 75% REQUIREMENT.**

Whenever pronouns or other references denoting gender appear in this document, they are written to refer to either male or female unless otherwise indicated.

**THIS PAGE INTENTIONALLY LEFT BLANK**

## INTRODUCTION TO OPERATION OF AUTOMATIC PRINT PROCESSORS

This subcourse contains three lessons on the operation of automatic print processors. These processors are becoming more common in Army laboratories throughout the world. Your understanding of their operation will help make you a better still photographic specialist.

Lesson 1 deals with the preparation of a processor and Lesson 2 explains how to operate the processor. Lesson 3 tells you how to process paper.

LESSON 1  
PREPARE AN AUTOMATIC PRINT PROCESSOR

TASK

Describe the components, purpose, and operation of the automatic print processor.

CONDITIONS

Given information about the components, purpose, and operation of various models of automatic print processors.

STANDARD

Demonstrate competency of the task skills and knowledge by responding to the multiple-choice test covering components, purpose, and operation of automatic print processors.

REFERENCES

None

Learning Event 1:

DEFINE THE CAPABILITIES OF THE AUTOMATIC PRINT PROCESSOR

1. Automatic print processors are made to provide for more rapid processing of photographic papers and to eliminate many of the variables in the processing of paper.
2. Photographic processors are other machines or automatic systems used in place of manual processing in order to handle a greater volume of material in less time and with more consistent results. Processors suitable for small darkrooms or low-volume applications are usually drums, tubes, or roller-transport devices such as stabilization processors.
3. More sophisticated processors can be used to achieve both efficiency and economy wherever high-volume output is required or large-sized materials are handled. These include:
  - a. Film processing and printing labs;
  - b. Busy illustrative and portrait photo studios;
  - c. Industrial and corporate photo departments;





- d. Reprographic concerns handling architectural or engineering drawings and similar originals;
  - e. Surveying, mapping, and reconnaissance-surveillance organizations;
  - f. Public relations and other concerns with a need to produce or distribute multiple copies of photographs.
4. The Kodak Print Processor (fig 1-1) will deliver a 10-inch print in about 55 seconds with a production capability for 720 8- by 10-inch prints per hour.

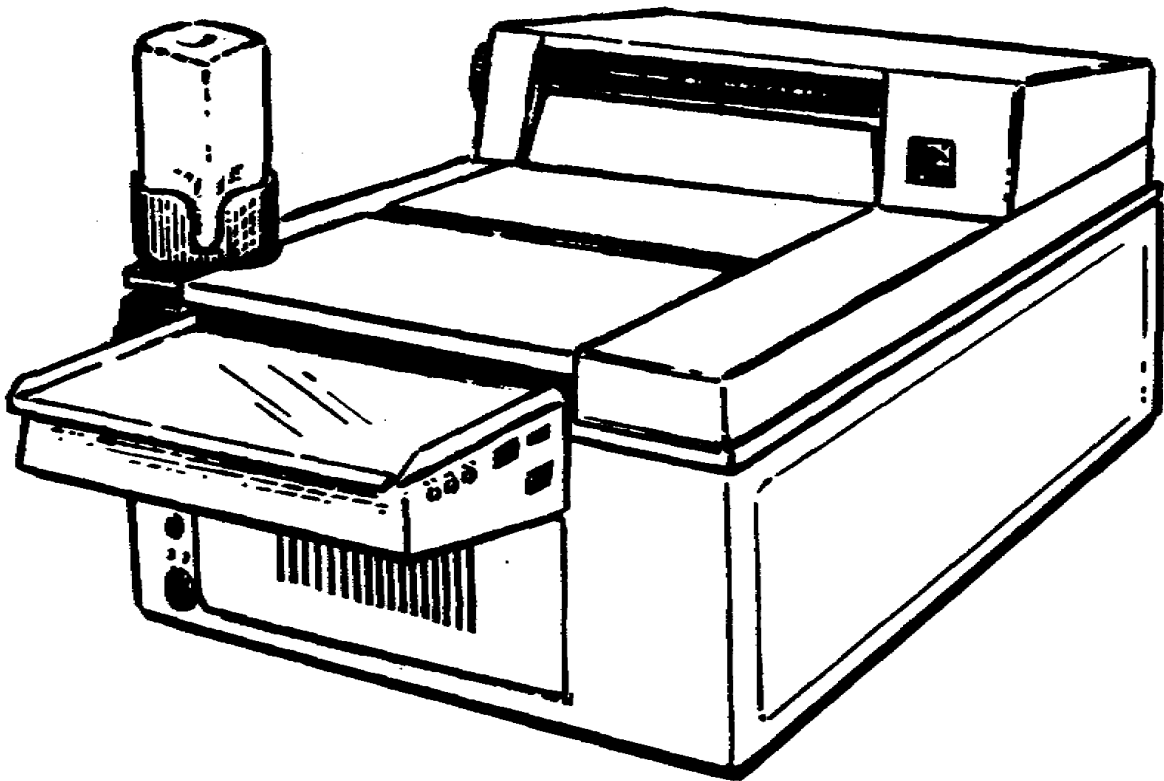

Figure 1-1. Kodak print processor

5. Figure 1-2 illustrates a Kreonite Krematic 16-inch tabletop processor. It can be set up to process color paper or black and white paper using normal color and black and white chemistry.

- a. The overall length is 61 inches and installation is very easy. The processor also has an optional light seal kit that is available for “thru the wall” installations. Production capacity for color processing is 84 8- by 10-inch prints or 47 square feet per hour. The entire process from dry-to-dry is 11 minutes.

- b. The black and white process is much more rapid, producing 420 8-by 10-inch or 235 square feet per hour. From dry-to-dry the entire process takes about 2 minutes.
- c. The Kreonite Krematic is a variable speed processor.

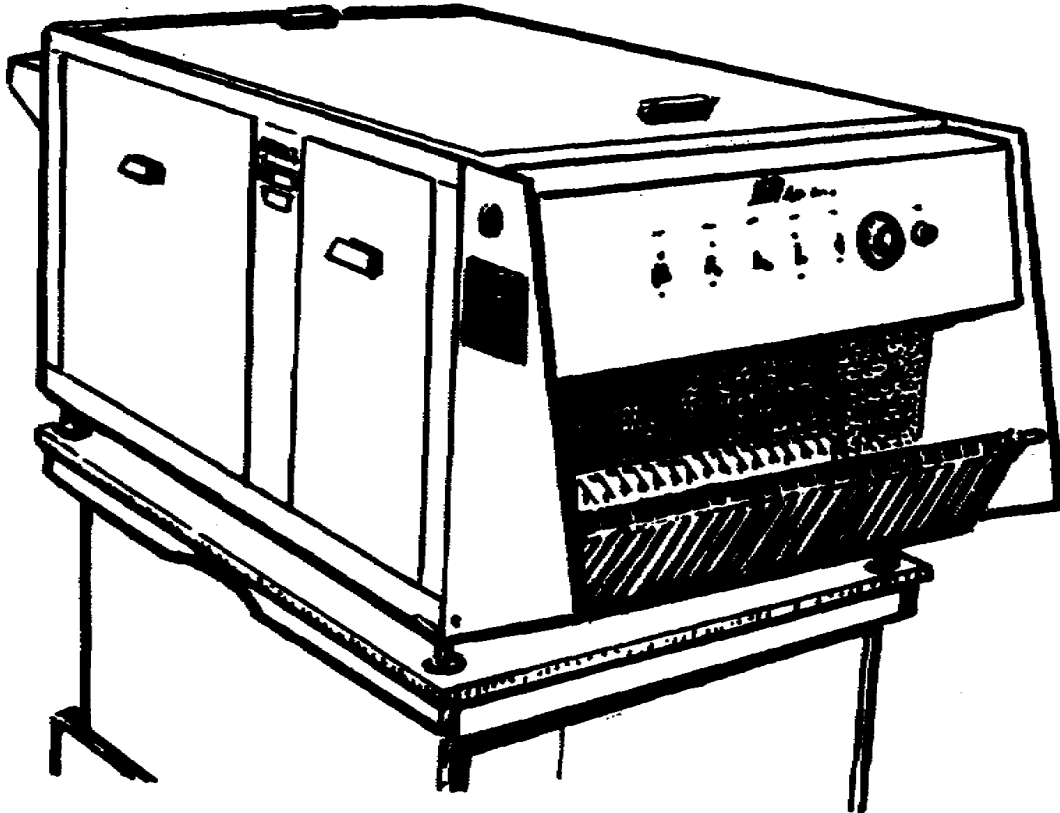

Figure 1-2. Kreonite Krematic processor

6. Figure 1-3 represents a floor model processor, the Ilford Ilfospeed 2240 black and white print processor. It has a production capability of up to 580 8 by 10 prints per hour. Dry-to-dry time is only 67 seconds. It can be set up to run all standard roll sizes and can accept paper up to 17 inches wide for even higher throughput. The 2240 processor is a one-speed processor but feeds through a remarkable 62.2 inches per minute.

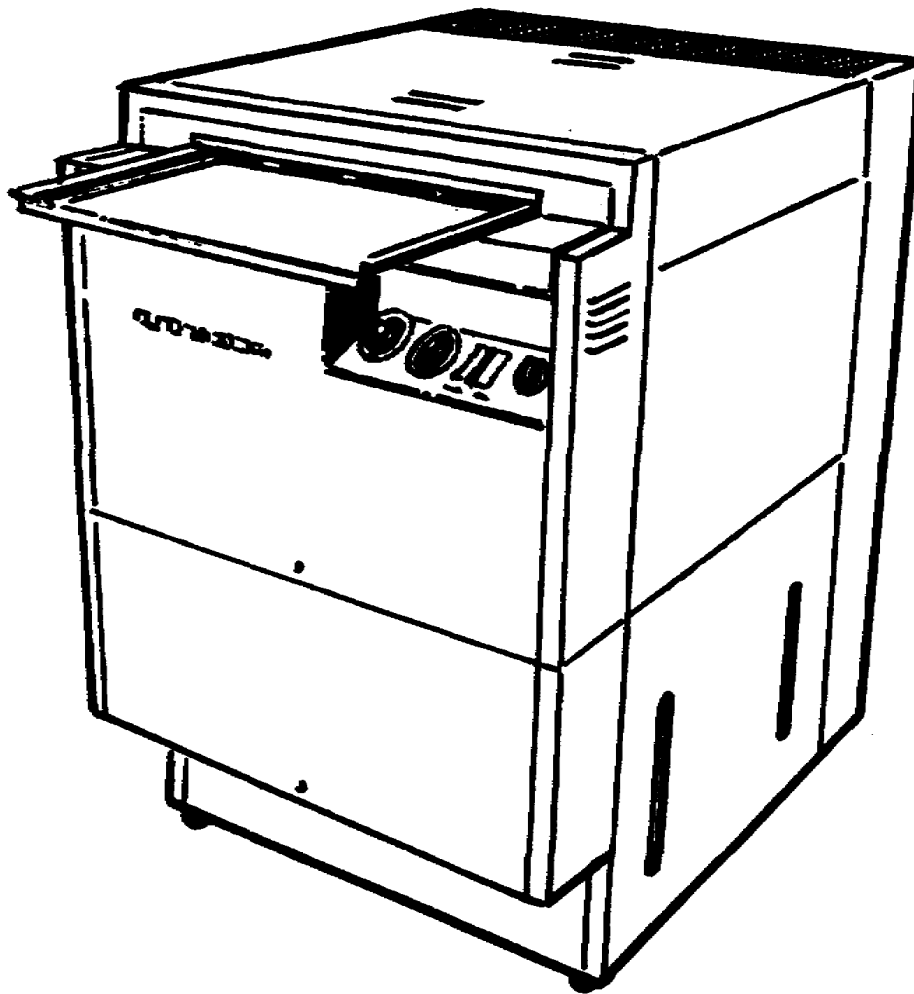

Figure 1-3. Floor model processor

7. Print processors are versatile in what they can do and accomplish in a short time. By far the greatest speed and efficiency is achieved by processing materials in continuous lengths. Commercial labs utilize print paper in rolls up to several hundred feet long; short rolls may be spliced together to form greater lengths. Similarly, roll and cartridge-load films are spliced into continuous lengths. Motion picture film is handled in the same way. A leader strip or a roller-transport is used to pull/transport the material through the various solution tanks, washing and drying stations. The material is moved at a constant speed; the size of the tank and the length of the path through it, which is established by a multiple series of rollers, determine how long the material remains in each solution. As the dry processed material emerges from the processor and moves past an inspection station, there may be attached to the processor equipment that will automatically trim, mount, sort, and even package the results.

8. It is important to know that mission requirements may differ from one Army photo lab to another causing different equipment to be used from lab to lab. One lab may have a need for a large continuous print processor for processing roll-type paper, i.e. a unit that gathers information, another may

have only a small tabletop model if requirements call for only 8-by 10-inch portraits, i.e., post commander and staff, chain of command, and for promotion purposes for soldiers in the grade of E6 and above.

9. Remember that the function of a processor is to give efficient and uniform development to the material being processed and the purpose is to handle a greater volume of material in less time and with more consistent results.

10. The economies in staff, materials, and time that may result from using a processor are not always readily apparent. Consultation with a manufacturer's technical or sales representative can be extremely valuable in deciding whether your lab actually needs an automatic processing machine and when to invest in one.

Learning Event 2:

#### DESCRIBE THE OPERATION OF THE AUTOMATIC PRINT PROCESSOR

The basic processor is one that will develop, fix, wash and dry a print in a specified amount of time. It is the same as processing in a tray.

1. Processors come in many shapes and sizes but all operate in the same manner using conventional chemistry depending on the type of material being processed, i.e. Kodak Ektacolor 74 and 78 RC Papers in Kodak Ektaprint 2 and Ektaprint 3 chemicals or Kodak RC B&W Print Papers in Kodak D-76 B&W chemical developer.

2. Material to be processed is inserted into the processor and transported through the machine by a series of rollers or by a belt-driven system which needs a leader. The paper is transported through the various chemical solutions; wash section, and finally the dryer section. It then exits the processor onto a roller or basket. The only exception to this is the processor that uses the stabilization process which will be discussed later.

3. High-volume processors automatically control temperature, timing, and cycling throughout the process. The most modern and complex processors are computer-controlled by stored programs; punched card, disk or tape, and electromechanical timer-thermostat devices.

4. Print processors that handle sheet materials commonly use either roller-transport systems or baskets connected to belts or chains; mesh dividers keep prints separated in each basket.

5. The primary task of the operator is to prepare, start, and stop the processor; feed print material in; and remove the finished results. Operating personnel may also monitor results by making periodic checks and tests at various processing stages, and adjusting processor operation accordingly.

6. Operation of a Continuous Print Processor includes the following steps:

- a. Paper is fed into the feed entrance (fig 1-4) or attached to a clip which is fastened to a belt (fig 1-5).

- b. The paper then enters one or more developer tanks.
- c. It then goes onto the fixing tanks, then the wash tanks.
- d. The dryer section receives the paper and transports it upward between a set of rollers to be air-dried (fig 1-5).
- e. The developed and dried paper then passes into a receiving bin for sheet paper or onto a take-up adaptor for roll paper.

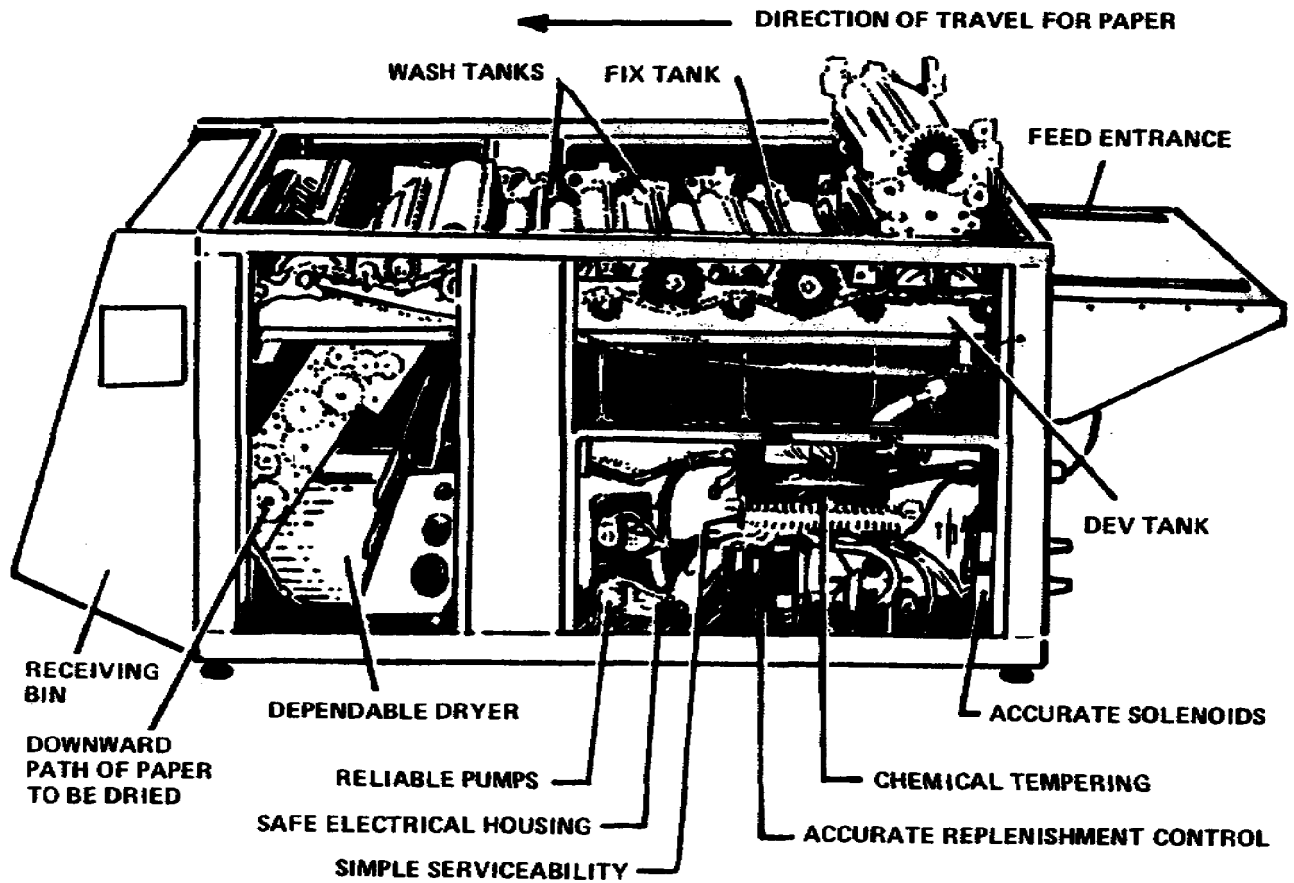

Figure 1-4. Continuous print processor

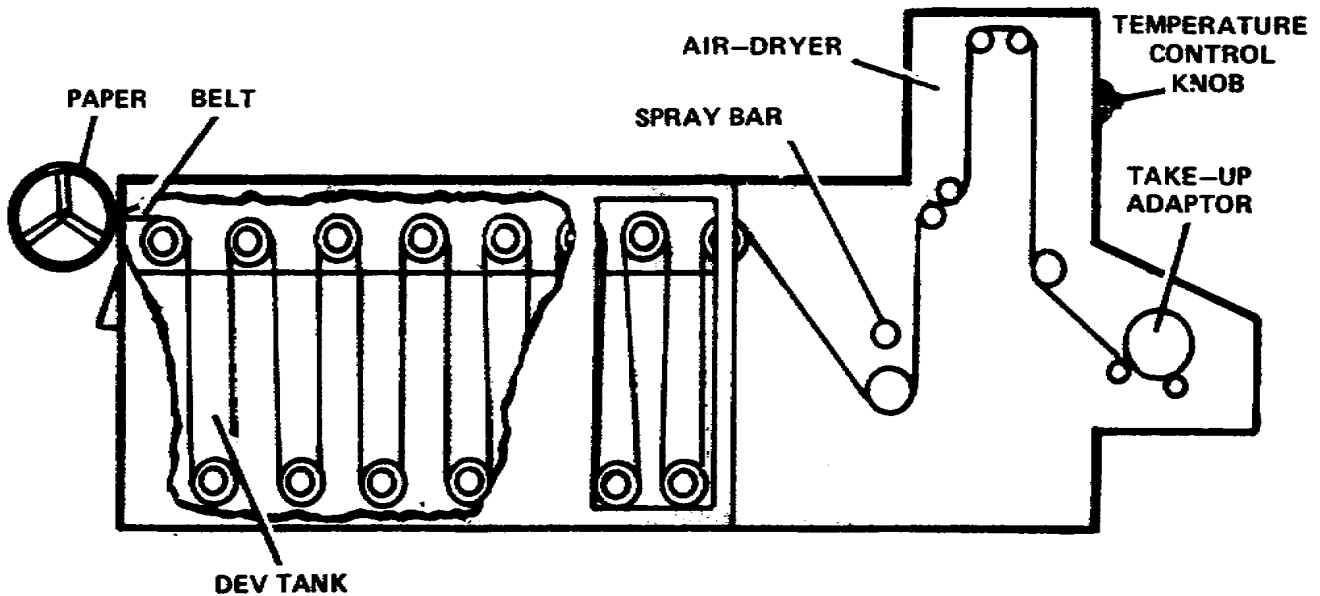

Figure 1-5. Belt-drive transport system

Learning Event 3:

IDENTIFY THE MAJOR COMPONENTS OF AN AUTOMATIC PRINT PROCESSOR

1. Major Components. All processors have basically the same major components. A processor will have a paper transport system, a replenishment system for developer and fix, a water circulation system, a filtration system, a temperature control unit, a recirculation system, a dryer system, and an electrical system.
  - a. The number of processing tanks will vary with the type of processor, i.e. B&W processor will have four tanks and a color processor will have at least five tanks.
  - b. Other equipment will include storage containers for chemistry and flow meters to regulate the amount of replenishment.
2. Paper Transport System. One of the more important areas of machine design is the paper transport system. The paper must be transported through the solution tanks at a constant rate of speed. Ideally the speed is adjusted if the situation warrants. A processor will have a roller transport or a belt-drive transport.

a. In the roller-transport system the paper is guided through the machine by a series of rollers that are placed in a staggered pattern (fig 1-6). This type of system is usually found in the smaller type processors but can also be found in some of the larger floor models. The size (width) of the paper to be processed is only dependent upon the maximum width allowed by the processor.

b. The belt-drive system uses a belt that is threaded through the machine between the outer ends of the rollers. The paper is threaded through a clip which is then attached to the belt to be transported through the machine for processing (fig 1-7).

c. Of the two types of transport systems, the roller-transport is the more efficient and better of the two. A roller-type system provides better tracking. Materials are squeegeed while passing through exit rollers before being transferred to the next step and the roller also gives a mild agitation effect, an important technique in the proper development of photographic materials.

d. Finally, drive systems generally consist of a motor, a variable speed transmission, and a drive chain which produces rotation of the transport rollers, usually through a system of clutches.

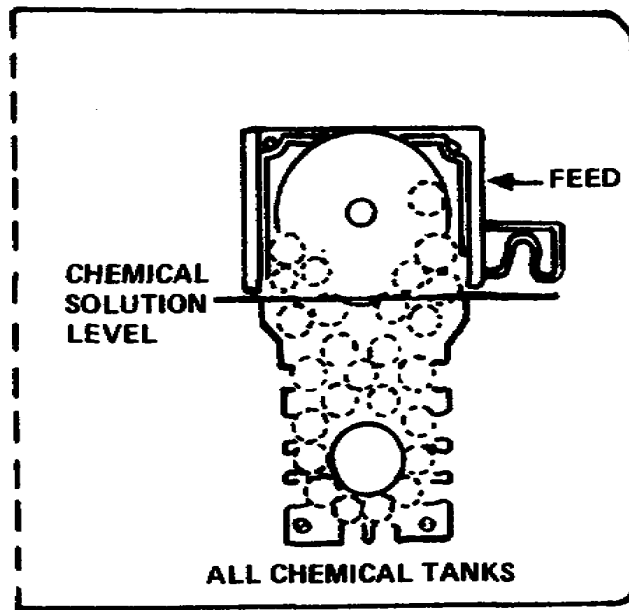

Figure 1-6. Roller-transport system

e. Paper is inserted through clip, clip attached to belt, belt transports clip and paper through processor.



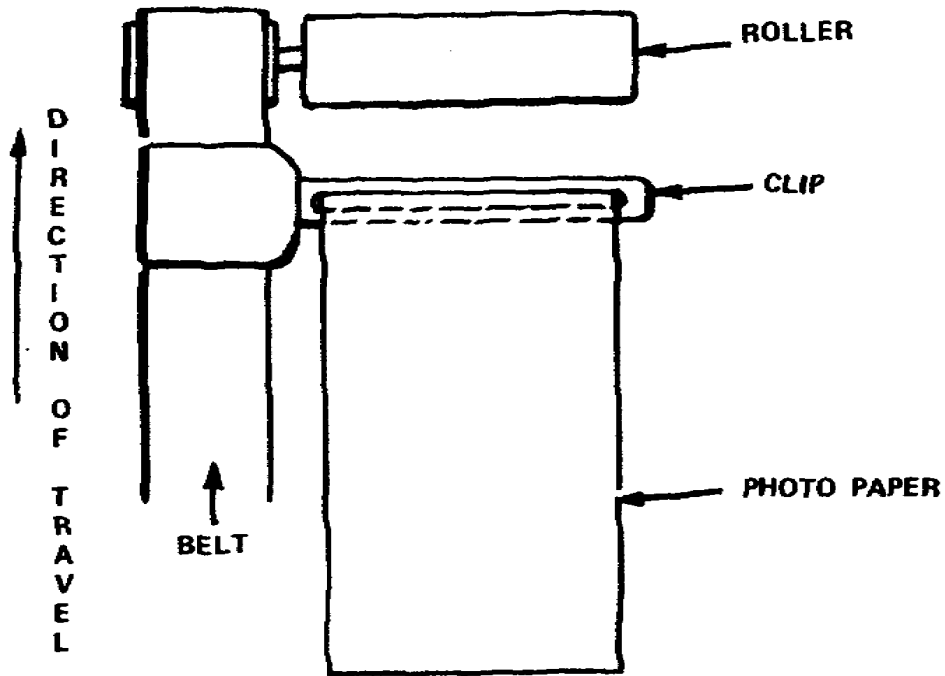

Figure 1-7. Paper feed with clip

3. Circulation system.

a. Agitation is the technique of moving the solution around the photographic material being processed to ensure more even development by bringing fresh chemistry into contact with the paper.

(1) There are numerous types of agitation systems used in print processors but the method most used and perhaps the oldest is the immersion method of agitation (fig 1-8). In this system, the paper travels through the various solution tanks and receives agitation solely from its movement through the tanks.

(2) The immersion system is the least expensive and the easiest agitation method to maintain.

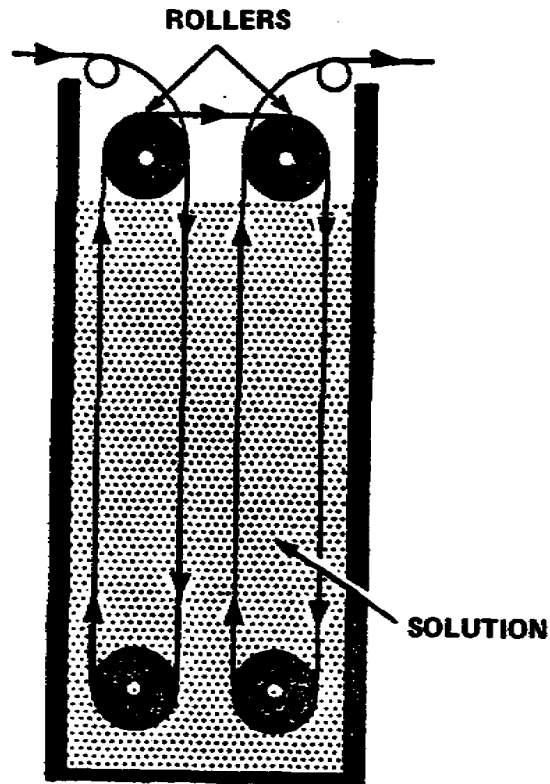

Figure 1-8. Schematic of a typical immersion processing tank

b. Recirculation system (fig 1-9) performs four important functions in processing machines.

- (1) Filters the solutions.
- (2) Controls the temperature of the solutions.
- (3) Provides a logical place to add replenisher to the solutions.
- (4) Provides a certain amount of agitation to the solutions.

4. Filtration. Solutions are generally filtered before they are reintroduced into the machine. Solutions are filtered and recirculated on a continuous basis during machine operation.

a. Filtration is accomplished through the use of screen or cartridge filters. The particle size passed by the filters is very important.

b. Most processors use filters that will filter out all particles larger than 10 microns. Wash water must be filtered to the same degree as the chemical solutions. Instruments used on the solution filter system should include pressure gauges on the inlet and outlet of the filter to indicate the pressure drop across the filter system.

c. The pressure drop signals when the filters are becoming clogged and need cleaning or replacing.

5. Temperature control. Controlling the temperature of your chemistry is very important to ensure that your materials are processed properly. This is accomplished by a temperature control unit referred to as a heat exchanger.

a. The heat exchanger incorporates refrigeration coils and heating elements. The developer and fixer are pumped through separate exchangers. The chemicals are adjusted to the proper temperature and reintroduced to the processing machine.

b. A temperature sensing probe, located in the processing tank, monitors solution temperatures and transmits this information to the solution thermostats. If solution temperature is too high, the refrigeration compressor is turned on and this drives the coolant through coils within the heat exchanger and cools the solution.

c. If the solution in the tank is too cold, the heaters located in the heat exchanger are turned on. This heats the solution. The operator sets the solution thermostats at the desired temperature and the solution temperature is automatically controlled.

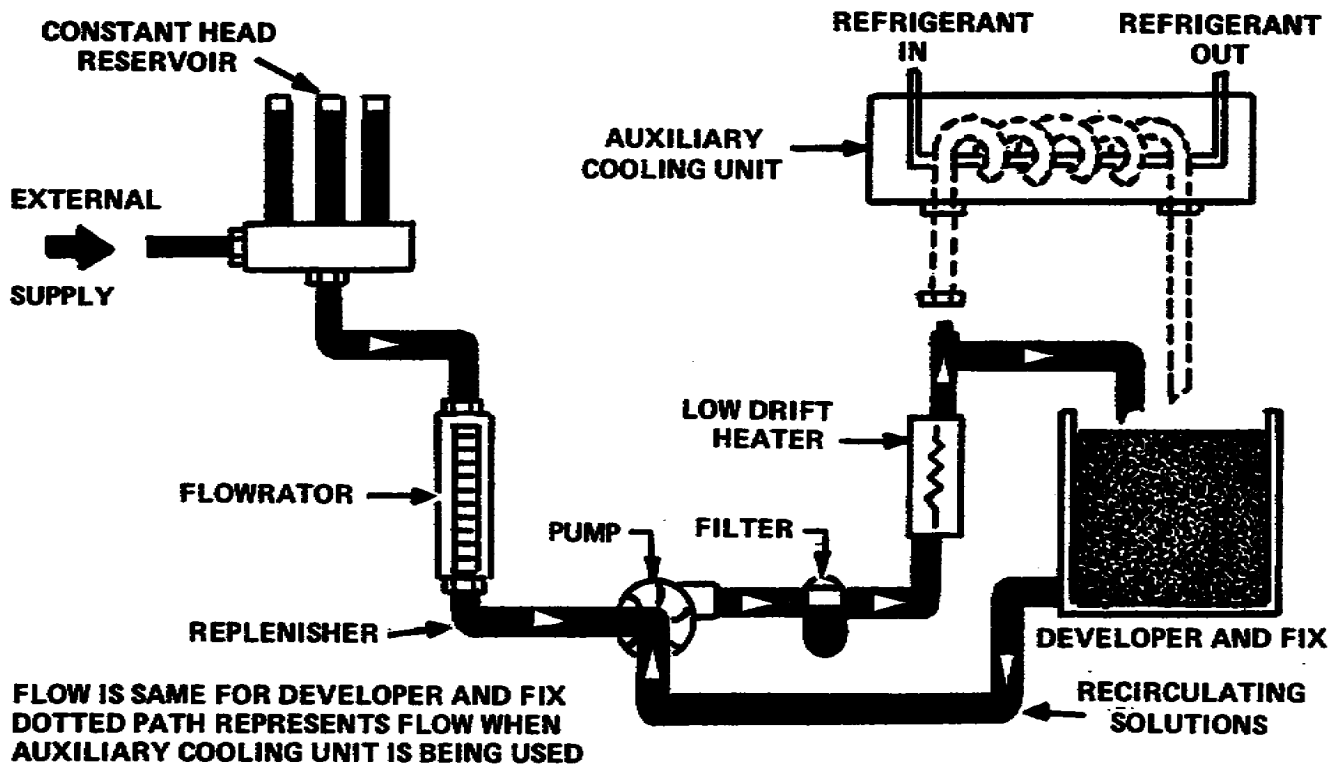

Figure 1-9. Typical recirculation system

6. Replenishment. The developer and fixer replenishment systems pump developer and fixer to the processing tanks from the storage tanks.

a. The solution is filtered before being introduced into the existing chemistry in the processing tanks. This is necessary because the chemistry in the storage tanks is undiluted and if added directly to the solution tank would cause uneven development and fixation.

b. The replenisher pumps can be operated continuously or automatically and are usually controlled by micro-switches located at the food entrance of the processor. They sense the materials as they enter the machine and activate solenoids adding the right amount of replenisher.

c. The purpose of replenishment is to maintain the activity of the solution at a constant level throughout processing operations.

7. Water Circulation. The water circulation system on a processor operates from regulated pressure through a water mixing valve and a flow meter. It provides fresh water to the wash and spray tanks. Water temperature is regulated by a thermostatically controlled valve in the mixing valve.

8. Drying Systems. The drying of paper is a simple task for a print processor. The papers being used most often today are resin-coated (RC) and absorb less chemistry than a paper that is not an RC-type paper. Less chemistry is absorbed allowing for easier removal of the various solutions and a more rapid drying pace.

a. Processors dry paper by two methods, forced-air, heat, or both. Larger processors use the forced-air method and have a housing at the end of the machine where the paper enters to have warm air blown over it to be dried. Smaller machines use a combination of heat and forced-air to dry paper.

b. It is important to know the drying temperature for your particular type of paper. All photographic papers are not made to be dried at the same temperature. Some problems that can occur if the temperature is incorrect are water spots if the temperature is too low and excessive curling of the paper if the temperature is too high.

c. The exact limits are dictated by the material being dried, and the type of dryer being used.

9. Safety. There are three basic areas of safety: chemical, electrical, and mechanical. When you are working with a print processor, you will be confronted by all three areas simultaneously.

a. Chemical. When working with photographic solutions you should always consider that they will be harmful if mishandled. Never try to determine the contents of a container by sniffing. If in doubt discard it and obtain a bottle that is properly labeled. When mixing chemicals always wear protective clothing to include eyewear and rubber gloves and always follow the manufacturer's instructions. Most important of all, never add water to an acid or alkali. Remember AAA - Always Add Acid or Alkali to water.

b. Electrical. Electrical equipment always presents the possibility of shock. Make sure that your equipment is connected to the proper power source and that it is properly grounded. If in doubt, have a qualified person check it out. And under no circumstances should you ever operate equipment with wet hands.

c. Mechanical. Processing machines are filled with gears, chains, drive shafts, and other moving parts. Keep hands away from these while the machine is running. Be especially careful of loose-fitting clothing and remove all jewelry when around processors.

**Note: Try to remember at all times that safety is a continuous job. The importance of safety can not be stressed enough. If you find an unsafe condition report it immediately to your supervisor. It's always better to be safe now rather than sorry later.**

## PRACTICE EXERCISE

1. Print processors are used in place of\_\_\_\_\_.
2. Print processors can handle a greater volume of work and are more consistent and economical.
  - a. True
  - b. False
3. The material being processed is moved at an irregular speed through the machine which produces acceptable results.
  - a. True
  - b. False
4. What is the function of a pressor?
5. What is the purpose of a processor?
6. What is the best way to process photographic materials?
7. A print processors method of operation is similar to what method of processing?
8. What methods are used to move the material through the processor?
9. What is the primary task of the operator?
10. What is agitation?
11. What method of agitation is most often used?
12. The three areas of safety that a operator must be aware of are what?

## ANSWERS TO PRACTICE EXERCISE

1. Manual processing
2. True
3. False
4. Provide efficient and uniform development
5. Handle a greater volume of work
6. In continuous lengths
7. Tray processing
8. Roller-transport and belt-drive system
9. Start and stop the processor
10. The technique of moving the solution around the photographic material
11. Immersion
12. Chemical, mechanical and electrical

LESSON 2  
OPERATE AN AUTOMATIC PRINT PROCESSOR

TASK

Describe the methods of operation, maintenance of chemicals, and importance of silver recovery in using an automatic print processor.

CONDITIONS

Given information on the operation of the Kodak Royalprint Processor Model 417, the chemical requirements of the processor, and the importance of silver recovery.

STANDARDS

Demonstrate competency of the task skills and knowledge by responding to the multiple-choice test covering operation of automatic print processors.

REFERENCES

None

Learning Event 1:

DESCRIBE THE OPERATION AND CONTROLS OF THE ROYALPRINT PROCESSOR

1. The Kodak Royalprint Processor Model 417 fig 1-1 page 2 was designed to provide faster and better black and white print processing. In this lesson you will become familiar with the nomenclature and operating procedures of the Royalprint Processor.
2. The Kodak Royalprint Processor, Model 417, is a table processor that will process certain black and white photographic papers very rapidly. It is easy to operate and maintain and produces completely processed and dried.
3. Paper passes through three chemical solutions; activator, stop, and fixer, then through a wash section, and finally, through a dryer. Process time for a dried 8-by 10-inch sheet is about 55 seconds. For more rapid access, the processor has a wet print inspection station where you can inspect a print as soon as it has passed through the stop solution -about 21 seconds for an 8-by 10-inch sheet. You can then reinsert it for final processing.
4. Chemicals are supplied in batch form. Each batch will process one thousand 8-by 10-inch sheets, or the equivalent paper area in other sheet sizes; after this or one week, whichever occurs first, the three solutions must be changed.



5. The transport speed is 18.3 (6 ft.) per minute which allows processing up to seven hundred twenty 8-by-10-inch sheets per hour. This requires that paper be fed into the machine with a 2-inch spacing between sheets and the sheets are fed two at a time, side by side.

6. Processor Controls. The controls and indicators of the Kodak Royalprint Processor, Model 417, consist of the following: (fig 2-1).

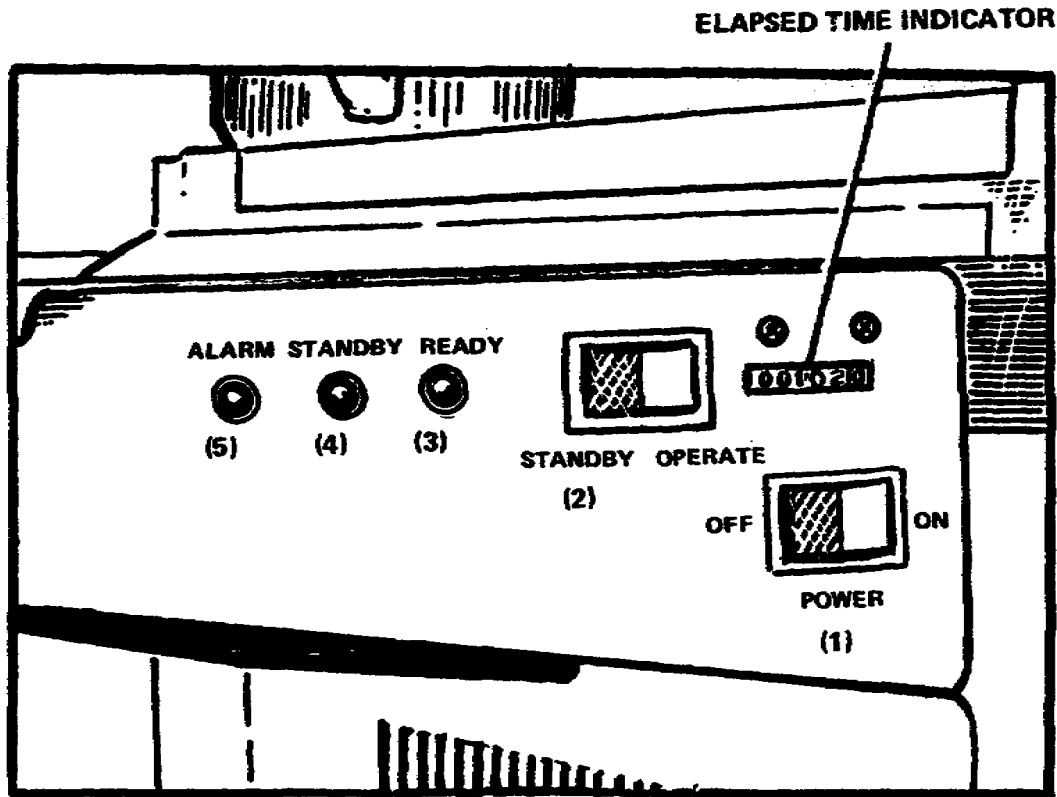

Figure 2-1. Controls and indicators

a. POWER Switch. This switch controls power to the processor.

b. STANDBY/OPERATE Switch. When placed in the OPERATE position, it energizes all circuits for normal operation. When placed in the STANDBY position, the processor is not operational. This conserves water, power and chemicals. It should be placed in STANDBY whenever the processor will not be used for more than 5 minutes. The cycling timer will automatically run the processor for 3 minutes, shut it down for 9 minutes, then run it again for 3 minutes. This cycling will continue until you are ready to use the machine again.

c. READY Light. The READY light, which is red, comes on when the power switch is ON and the Standby/Operate switch is on OPERATE. When the processor is warmed up and ready to operate, the light will blink on and off.

d. STANDBY Light. The yellow standby light comes on and remains on when the Standby/Operate switch is on STANDBY.

e. ALARM Light with buzzer. The amber ALARM light and buzzer both turn on for the following alarm conditions:

- (1) Top cover is ajar.
- (2) Fixer solution is low.
- (3) Wash water is low.
- (4) Lack of solution or air lock in fixer line.
- (5) Fixer solution too high.
- (6) Drier air temperature is too high with fan working.
- (7) Drier fan inoperative.

f. If an alarm condition occurs, power is interrupted at the main relay. Reset the relay by turning the power switch to OFF and then to ON. If the alarm sounds again, DO NOT reset the relay. The problem causing the alarm must be located and corrected.

g. Elapsed Time Indicator. The digital readout registers the amount of hours that the motor drive has run.

#### Learning Event 2:

#### DESCRIBE THE START UP PROCEDURE FOR THE KODAK ROYALPRINT PROCESSOR

1. The task of starting. A processor is not difficult but does require that the operator know the procedure well enough to successfully start the processor without benefit of the operator's manual. Two procedures are described below: initial start-ups and daily start-up procedures.

a. Initial Start Up. Most processors require a special sequence of initial start up. You must follow the instructions that come with your processor.

(1) Remove the top cover by lifting at the feed end and then straight up. Then remove the side panel.

(2) All drain valves must be closed if so equipped. This usually includes activator, stop bath fixer and water valves.

(3) Pour in the recommended amount of activator into the fill receptacle. Usually a funnel is required.



**WARNING: Most activators are caustic. Avoid contact with your body. Wear eye protection and gloves. If the activator comes in contact with your skin, flush with water. If activator touches your eyes, flush with water and seek medical help immediately.**

(4) Pour in the proper amount of stop bath into the stop bath receptacle. Again, a funnel is usually required. Do not spill chemicals on the machine.

(5) Fill the fixer receptacle with water first to the lower mark of the fixer sight gauge. Using the funnel if required, pour the proper amount of fixer into the fill receptacle. Water must then be added as required.

(6) Always fill the machine in the proper sequence to avoid contaminating the chemicals.

(7) If required, pour water into the water fill receptacle. There is usually a sight glass to check the proper level. Disregard the lower mark and fill to the upper mark. The water must be at a certain temperature.

(8) If the processor is equipped with mixing valves for water temperature control, set them at the required setting.

(9) Follow all instructions as provided by the manufacturer when preparing any automatic processor.

b. Daily Start Up. After the initial start up procedures are completed, it is NOT necessary to follow daily start up steps. However, most processors require that certain steps be followed in bringing the processor up to temperature.

(1) Check the level of all solutions in the machine, according to the manufacturer's instructions. If necessary add water to the activator if solution level is low.

(2) Close the water drain if so equipped and add water as necessary. Water must be at the correct temperature.

(3) Most activators will evaporate. Make sure that sufficient activator is always available.

(4) Follow the manufacturers instructions for starting the processor.

(5) After the processor has warmed up, switch the processor to "standby" if no processing will be done for at least 5 minutes. This conserves energy, water, and chemicals.



Learning Event 3:

**DESCRIBE THE PROCESSING PROCEDURE USING THE KODAK ROYALPRINT PROCESSOR**

1. Processing Paper. The Kodak Royalprint processor is intended for certain black-and-white papers that are resin-coated and developer-impregnated.

a. The paper can be as wide as 17 inches. For proper transport the paper must be at least 5 inches in length, with a maximum length of 20 inches. The paper must also be in sheet form, the machine does not process roll paper.

b. Before beginning to process any prints, you should give some thought to maintaining a log sheet of print sizes and the amount of paper processed in the machine. This information is helpful in that it will let the operator know when to change the chemical solutions for a new batch. There are three conditions the operator should keep track of:

- (1) Processing the equivalent of 1,000 8- by 10-inch prints (fig 2-2).
- (2) When the solutions are 1 week old.
- (3) When you have used three bottles of water to replenish the activator.

NOTE: Whichever condition occurs first, you must change the chemicals.

<b>EQUIVALENT PRINT SIZE</b>	
<b>PRINT</b>	<b>EQUIVALENT 8 X 10</b>
<b>4 X 5</b>	<b>0.25</b>
<b>5 X 7</b>	<b>0.44</b>
<b>8 X 10</b>	<b>1.0</b>
<b>8 1/2 X 11</b>	<b>1.2</b>
<b>11 X 14</b>	<b>1.9</b>
<b>14 X 17</b>	<b>2.97</b>
<b>16 X 20</b>	<b>4.0</b>

Figure 2-2. Equivalent print size

## 2. Processing Procedure

- a. Press the OPERATE/STANDBY switch to "Operate."
- b. Feed the exposed paper emulsion down into the machine. Always insert the paper lengthwise into the machine for a more reliable transport.
- c. In approximately 55 seconds your print will clear the dryer exit. If you do not plan to process any more prints for at least 5 minutes, press the OPERATE/STANDBY switch to standby. Make sure that all prints have cleared the machine.

## 3. Wet Print Inspection

- a. The Royalprint has a wet print inspection station that is located between the stop and fixer stages. Access time for a 10-inch long print is about 21 seconds. After the print has been inspected reinsert it emulsion down to complete the process.
- b. To use this station, raise the hinged cover, figure 2-3, and prop it in place by raising the hinged curved piece that is below it so that the edge of the cover catches the edge of the curved piece, as shown in figure 2-4. Prints will now automatically exit at this station due to the position of the inspection shoe actuator.
- c. To reinsert a print, place it emulsion down, and feed the leading edge of the print into the slot just beyond the inspection shoe. Feed it squarely into the machine so that the transport rollers catch the entire leading edge of the print evenly, and begin moving it.

NOTE: If the print is not fed emulsion down, proper fixing of the print will not take place.

**HINGED COVER**

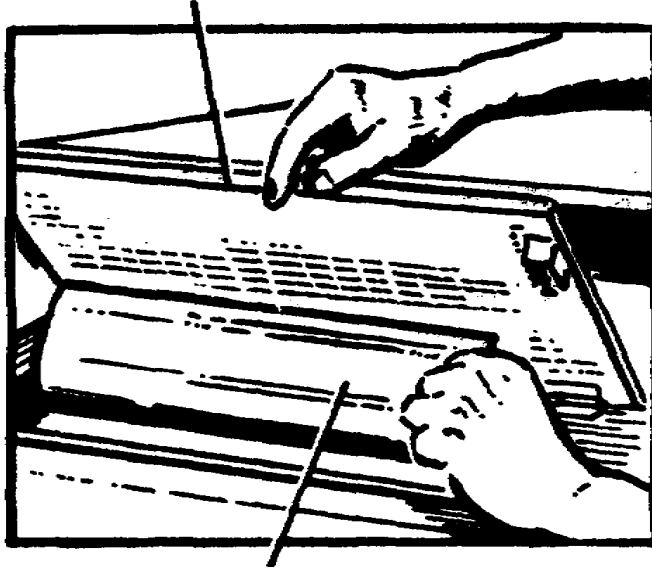

**HINGED CURVED PIECE**

Figure 2-3. Hinged cover

**INSPECTION SHOE**

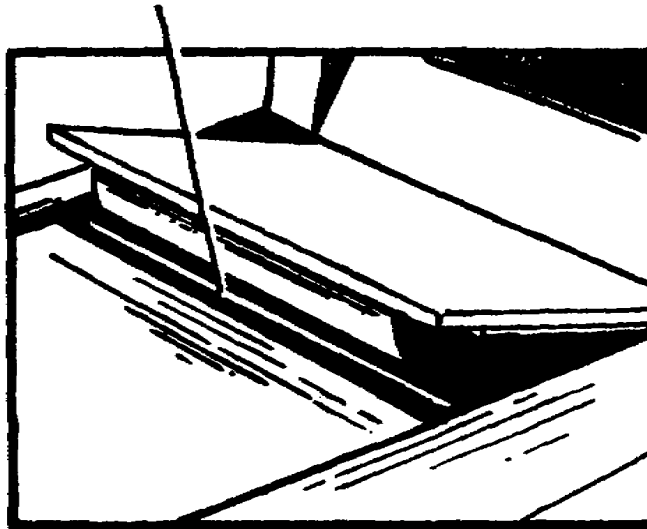

Figure 2-4. Inspection shoe actuator



Learning Event 4:

DESCRIBE THE SHUTDOWN PROCEDURE FOR THE KODAK ROYALPRINT PROCESSOR

1. Turn the processor power switch and main power (wall) switch to OFF.
2. Turn off the water supply.
3. Remove the activator supply bottle.

WARNING: Activator is very caustic and therefore should not be allowed to come into contact with the body.

4. Remove the top cover. Make sure that the activator supply bottle is removed first.
5. Insert the splash guard in front of the activator/stop rack; then replace the top cover onto the splash guard. Do this by setting the rear end of the cover down first. Set it down a few inches in front of the dryer cover. Lower the front gradually down to the splash guard while sliding the cover a short distance to the rear at the same time. With the splash guard in place, the cover will not come low enough to contact or harm the inspection shoe actuator as you slide it.
6. Remove the side panel and open the water drain valve. When this has been done you can replace the side panel.
7. Wipe any chemical or water spillage off the machine with damp cloth or sponge.

Learning Event 5:

DESCRIBE THE PROCEDURE FOR CHANGING CHEMICALS IN THE KODAK ROYALPRINT PROCESSOR

1. The Royalprint is designed for batch chemical operation. When the equivalent of one thousand 8-by 10-inch prints, after a week elapses, or after three bottles of water have been used to replenish the activator, whichever occurs first, the chemicals in the processor must be changed.

NOTE: If you exceed these limitations print quality and permanence will be impaired.

2. When changing chemicals, follow these steps:
  - a. Turn off the processor power switch and the main power (wall) switch.
  - b. Remove the activator bottle.
  - c. For processors that are equipped with silver-recovery equipment, do not proceed further without reading the silver-recovery information that follows this procedure. Modify this procedure, as needed, to accommodate your equipment. For all processors, open the activator, stop, and fixer drain

valves.

- d. Do not drain the wash water unless you are changing the chemicals at the end of the day.
- e. Insert the splash guard in front of the activator/stop rack.
- f. Rinse the activator/stop rack, without removing it from the processor. The fill hose can be used to do the rinsing.
- g. At each chemical change, remove the fixer rack from the processor and clean it in a large sink to remove any chemical buildup. To do this, remove the dryer cover first, then the dryer transport rack and last the wash section cover. Use warm water and a soft brush or sponge.
- h. Place the clean racks in the processor.
- i. Give all sections time to drain completely; then close all drain valves and add new chemical solutions as outlined under initial start-up.
- j. Record the date/time of chemical change.

Learning Event 6:

#### IDENTIFY THE IMPORTANCE OF SILVER RECOVERY

1. Although it is optional, visual information units should install silver recovery equipment for two reasons: It saves you money, and, it reduces silver to levels which are low enough to comply with local codes. This protects the environment from high levels of waste.
2. A satisfactory hookup for silver recovery is shown in Figure 2-5. All of the chemical solutions; activator, stop bath, and fixer are drained through two KODAK Chemical Recovery Cartridges, Type 2-P, connected in series.
  - a. For satisfactory flow, the first cartridge must be about 4 to 6 inches higher than the second cartridge.
  - b. The wash water drains through the usual separate water drain.
3. To drain the chemicals through the cartridge:
  - a. Turn the three-way-valve handle toward the line leading to the first cartridge.
  - b. Open the activator, stop, and fixer drain valves until the processor sumps are empty.
  - c. Turn the three-way valve handle away from the cartridges so that the rinse water will bypass them and go directly to the drain during the rinsing procedures.

d. Be sure to bypass the cartridges with the rinse water. This prevents dilution of the chemicals retained in the cartridges and permits maximum silver recovery.

4. After the rinse water has drained, turn the three-way valve handle toward the cartridges again. Then close the activator, stop, and fixer drain valves to prepare the processor for the new batch of solutions.

a. Up to 30 batches of chemicals can be drained through the chemical recovery cartridges for the first reclamation.

b. The front or first cartridge is removed for reclamation and the rear cartridge is moved to the front or first position.

c. A new cartridge is installed in the rear or second position.

d. Thereafter, the front cartridge can hold a total of 60 batches before being removed for reclamation.

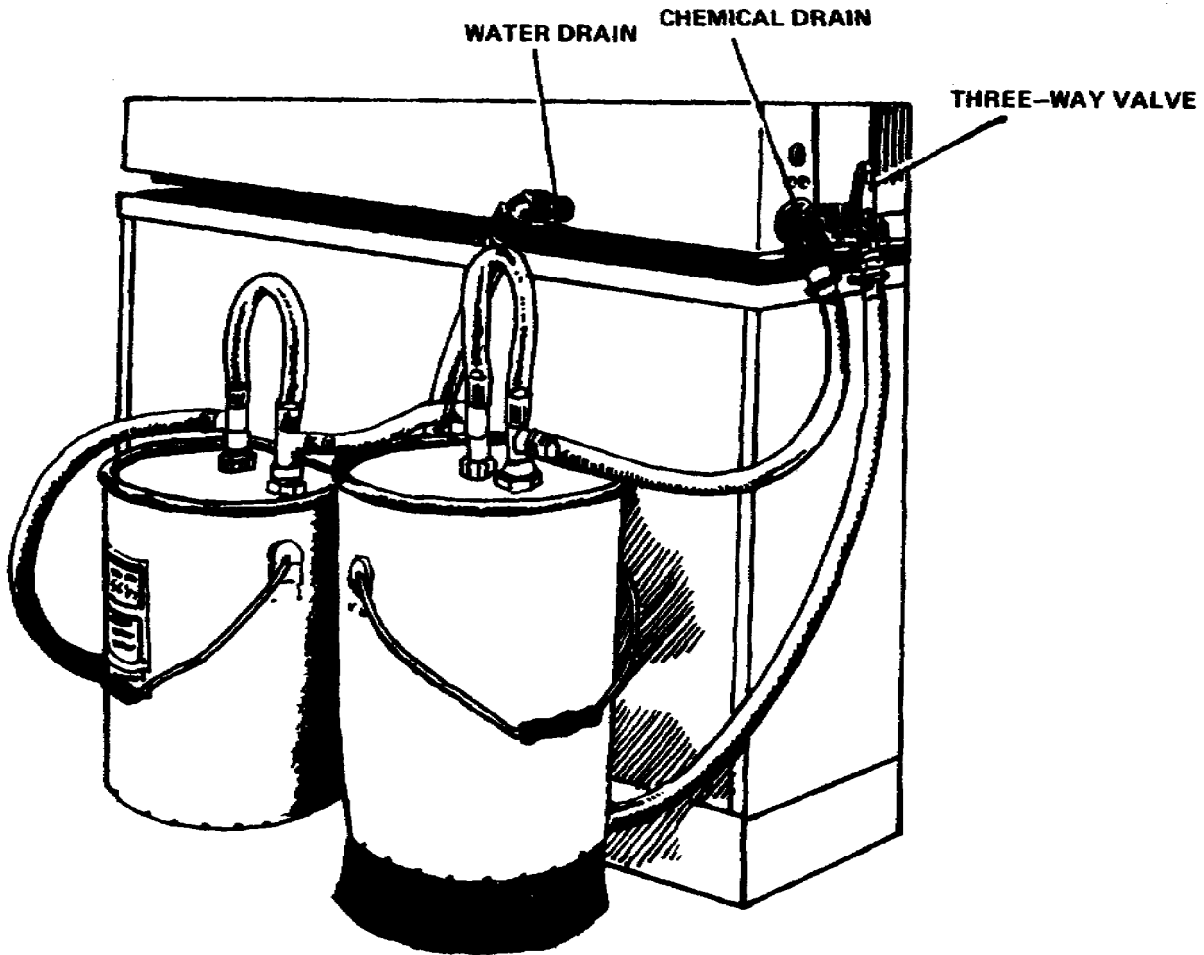

Figure 2-5. Hookup for silver recovery

## PRACTICE EXERCISE

1. During the initial start up why should the operator never slide the top cover of the processor?
2. How many bottles of Royalprint Activator are used during initial start up procedures?
3. What is the temperature range for the water?
4. What is the fixer temperature preset to?
5. How much warm-up time is needed if the fixer temperature is not at the correct operating temperature?
6. The Royalprint Processor will process a sheet of photographic paper in approximately
7. When must all the chemicals in the processor be changed?
8. Why is silver recovery important?
9. Exceeding the batch limitations of your chemistry can do what to your prints?
10. What is the first thing that you should do when shutting down the processor?

## ANSWERS TO PRACTICE EXERCISE

1. It can damage the Inspection Shoe Actuator
2. Three
3. 18 to 22°C (64 to 72°F)
4.  $43.3 \pm 1.7^{\circ}\text{C}$  ( $110 \pm 3^{\circ}\text{F}$ )
5. 30 minutes
6. 55 seconds
7. After 1,000 8- by 10-inch prints, one week elapses, or after three bottles of water have been used to replenish activator
8. Saves money and to comply with local codes
9. Impair print permanence
10. Turn off processor power switch and main power switch

LESSON 3  
PROCESS PAPER IN AN AUTOMATIC PRINT PROCESSOR

TASK

Describe the conventional, stabilization, and activation processes.

CONDITIONS

Given information on the methods of processing photographic paper using a Kodak Royalprint Processor.

STANDARDS

Demonstrate competency of the task skills and knowledge by responding to the multiple-choice test covering methods of processing paper in an automatic print processor.

REFERENCES

None

Learning Event 1

DESCRIBE THE CONVENTIONAL PROCESS OF PRINT PROCESSING

1. The Conventional Process.
  - a. Historically the oldest of the processes, the conventional print process consists of these steps:
    - (1) Develop
    - (2) Stop
    - (3) Fix
    - (4) Wash
    - (5) Dry
  - b. A conventional paper (not water-resistant) consists of a silver halide emulsion coated on a photographic paper base. A baryta (barium sulfate in gelatin) subbing is coated on the paper under the emulsion to provide a smoother, higher reflectance base for the emulsion.
  - c. The exposed silver halide crystals are converted to black metallic

silver during development, forming the photographic image. Unexposed and undeveloped silver halide crystals, still light-sensitive, remain in the emulsion.

d. The two most important components of a developer are the developing agents that are required to convert exposed silver halide to metallic silver, and a base or basic salt to make the solution alkaline. Other ingredients include a preservative (normally sodium sulfite) to inhibit oxidation of the developing agents.

e. The stop bath is usually a dilute solution of acetic acid. It stops the action of the developer and prolongs the life of the acidic fixing solution.

f. The fixing agent (hypo) converts the unexposed, undeveloped silver halide crystals, which are insoluble, into soluble silver salts that will wash out of the emulsion. The removal of these salts is necessary to make the print permanent--if left in the emulsion, they will darken in light.

g. With conventional fiber-base papers, the solutions penetrate the paper base. Complex silver salts formed in the fixer saturate the paper at the end of the fixing step. These must be removed both from the emulsion and from the paper base to prevent staining and fading of the image.

h. A wash of at least an hour in continually changing water at 20°C (68°F) is required for complete removal of these dissolved salts from single-weight base. A longer time is required for double-weight paper. The time required to wash the salts out of the emulsion alone is relatively short, about 4 minutes. Most of the long wash time is required to remove them from the base paper. The total time usually required for a conventional process up to the drying stage is about 1 hour and 15 minutes.\*

i. Drying prints on conventional papers can be accomplished in a number of ways. Air-drying of prints may take hours; this time can be shortened by blowing warm air over the drying prints.

j. Heated drums with canvas belts are used to speed up the drying process to a time of several minutes. Lustre and matte-surface papers are dried with the emulsion surface away from the drum. In order to attain a high gloss on conventional papers, the emulsion is ferrotyped against the smooth, polished surface of the drum.

k. Ferrotyping requires constant vigilance. The surface of the drum must be kept free of scratches, since such marks result in scratches in the ferrotyped surface of the prints. Also, the drum surface must be kept clean and polished so that prints do not stick to it.

2. Water-Resistant Papers: Water-resistant papers are made by coating the paper base on both sides with a resin layer. The coating on the emulsion side, which replaces the baryta coating on conventional papers, is pigmented white, or the same color as the paper tint. The pigmentation is unnecessary on the base side. Water does not penetrate the resin coating, and thus the

conventional processing of resin-coated papers requires a shorter time.

a. Because the fixer solution, with its dissolved silver salt content, does not penetrate the paper base, the wash time is shortened considerably—to 4 minutes. The developing and stop bath times are essentially the same as for conventional papers. The fixing time, however, is reduced from 10 minutes to 2 minutes.

b. The big saving in processing time for water-resistant papers occurs in the washing step. Instead of the minimum of an hour wash for conventional papers, a 4-minute wash time is recommended, in which time prints attain optimum stability. Further, prints made on water-resistant papers air-dry much faster than prints made on conventional papers.

#### Learning Event 2:

#### DESCRIBE THE STABILIZATION PROCESS

1. Some users require more rapid access to prints than can be achieved by the conventional process—even with water-resistant papers—and they have no need for permanence in the usual sense. For these users, the activation stabilization process is recommended. The Kodak Ektamatic Processor, Model 214-K, provides such a process.

a. In the conventional process, all the developing ingredients are in the developer and are carried into the emulsion by the solvent which is water.

b. In the stabilization process, the components of the developer are divided between the paper emulsion and the activator solution. The papers used in the stabilization process are developer-incorporated papers. The developing agents are in the paper emulsion, and the remainder of the necessary ingredients are in the activator solution.

2. Activation: While an activator could be at the same level of alkalinity as a developer solution, the activators actually used in the stabilization process have a much higher alkalinity to make the development more rapid. If a normal developer had as high an alkalinity as a typical activator, it would be caustic to hands. Also, a developer of very high alkalinity would oxidize the developing agents very rapidly—and would have a very short useful life. When the developing agents are in the paper, the activator can be highly alkaline and still have a long useful life.

3. In the Ektamatic Processor, development is completed in a few seconds by activator brought to the print surface by the roller mechanism. The paper does not enter the activator solution. The second, and last, step of this process is stabilization.

4. Stabilization: Stabilization is the chemical conversion of light-sensitive salts to other silver salts that are much less light sensitive. Such a print can be used as a proof print, as an original for graphic reproduction, or for any other purpose not requiring long-term permanence. Prints come from the processor immediately in a damp-dry condition and air-dry in several minutes. It takes only about 15 seconds for an 8- by 10-inch print to enter, be





activated, be stabilized, and completely emerge from an Ektamatic Processor. Stabilization processing is not recommended for resin-coated papers.

a. The unexposed, undeveloped silver-halide salts left in a print emulsion after development would turn dark in a few minutes if exposed to light. When stabilized, they turn dark very slowly; often the first signs of image deterioration show up only after months. Strong light, high temperature, and high humidity all help to shorten the life of a stabilized print.

b. A stabilized print can be fixed, washed, and dried in the conventional manner to obtain optimum stability.

### Learning Event 3:

#### DESCRIBE THE ACTIVATION - CONVENTIONAL PROCESS

1. A combination of fast black-and-white print processing and optimum stability is achieved with the Kodak Royalprint Processor, Model 417. The purpose of this section is to describe how the automatic processor works and to relate the process to previously available print processing methods.

2. This processor works by an activation-conventional process that produces dry prints with optimum stability in less than a minute. Until the advent of this new process, there had been two major methods of processing prints: conventional process and the activation-stabilization process. Each method has advantages and disadvantages.

3. This new activation-conventional process makes use of the best features of conventional processing, stabilization processing, water-resistant paper base, developer-incorporated emulsions, and specially designed equipment. Other important features make possible prints of optimum stability in a complete process time of less than a minute.

4. Activation: The diagram of the Royalprint Processor illustrates this activation process and shows how its many advantages are realized (fig 3-6).

a. The exposed print is placed emulsion-side-down on the feeder tray, where it enters the processor. The first pair of rollers are dry rollers in contact, and serve to transport the print down into the activator solution. The highly alkaline activator enters the emulsion, combines with the developer-incorporated particles, dissolves them rapidly, and develops the image in slightly less than 9 seconds. The activator does not require an elevated temperature--it operates in the range of 18 to 24C (65 59 75°F) with a tolerance of  $\pm 3^{\circ}\text{C}$  ( $\pm 5^{\circ}\text{F}$ ) about any temperature in the range. The activator is kept within the range by incoming tap water on its way to the wash section of the processor.

b. However, because tap water often exceeds this range, a thermostically-controlled mixing valve is furnished. The print leaves the activator via the last pair of transport rollers in the activator section. These rollers are in contact and act as squeegees, removing excess activator from the print.

5. Stop Bath. The first pair of transport rollers in the stop bath feed the print down into the stop bath solution, which requires about 5 seconds to stop the developing action to neutralize the alkalinity of the activator remaining in the paper emulsion.

6. Fixer. The three processing factors that determine the rate of a fixing process are formula, temperature and rate of agitation.

a. The most time-efficient fixing ingredient commonly used is ammonium thiosulfate, the ingredient used in Kodak Rapid Fixer. This is also used in Kodak Royalprint Fixer. There is a certain concentration of fixing agent that fixes fastest; it is neither the least nor the greatest concentration possible, but is at a certain intermediate level.

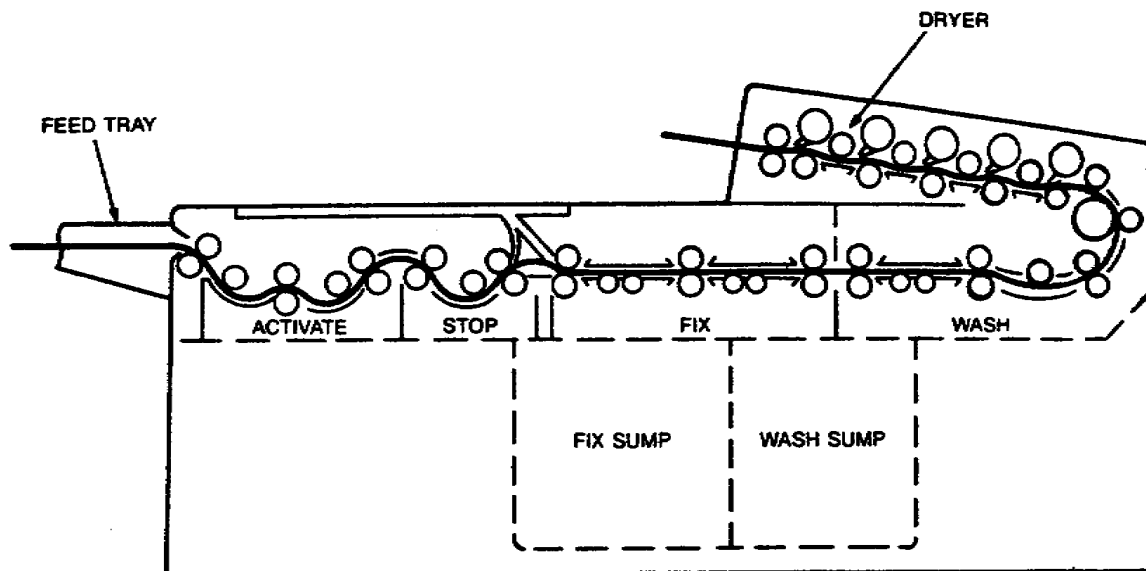

Figure 3-6. Activation process

b. When the Royalprint Fixer concentrate is diluted 1 to 3 with water, the best concentration is achieved. Increasing the temperature increases the function rate. The temperature of the fixer is kept at a normal 43°C (110°F). In order for the prints to stand this temperature without deterioration, a special hardened emulsion is used in the papers.

c. The print is fixed using fountain agitation in a narrow chamber about 3/16 inch in height. The high-turbulence fountain jet agitation in the relatively low chamber helps fix the paper rapidly. By keeping the paper close to jet openings, the rate of agitation is increased. By keeping the volume of the chamber relatively small the rate of change of the fixer in the chamber is increased.

d. The fixer is able to fix the print completely in about 10 seconds because of the combination of formulation, concentration, temperature, and highly efficient agitation.

7. Agitation. The high-agitation fountain achieves an increased rate of fixation because it removes used fixer from the emulsion and replaces it with fresh fixer at a high rate of speed.

a. The small chamber is equipped with two-stage, two-directional fountain jets, which are supplied with fixer under pressure. They provide an extremely high degree of agitation uniformly across the print surface.

b. The high turbulence results because the jets of fixer within the liquid filled chamber are aimed in opposite directions against the surface of the moving print. In addition to the direct jet action against the print surface, the jets cause the fixer to swirl rapidly in whirlpool fashion against the emulsion. As the print moves through the fixing section, the emulsion receives continual high-turbulence agitation from both of these actions.

c. The hardened paper emulsion is coated on a resin layer which is water-resistant. The fixer can penetrate only the emulsion, which reaches a fixer-saturated state immediately as it enters the fixing section of the processor. The resin coatings shorten the time both in the fixing and in the washing steps of the activation process.

8. Washing.

a. Complete washing takes place in the last wet section of the Royalprint Processor in slightly more than 8 seconds because of:

(1) The squeegee action of the feed rollers, which removes most of the fixer from the print surfaces.

(2) The water-resistant paper base.

(3) The high-turbulence fountain-jet wash-water application.

(4) A final clear-water rinse.

b. As the print leaves the fixing section, it is transported by two pairs of transport rollers. These rollers serve a second function; as well as moving the print along, they double-squeegee the fixer from the print, leaving very little surface fixer on the print as it enters the wash.

c. The water-resistant base has not allowed the fixer to penetrate the paper fibers. Therefore the back surface of the print needs only a rinse to eliminate any residual surface fixer, and the fixer needs to be removed only from the thin, porous gelatin emulsion.

d. Agitation of the wash water is provided by fountain jets, which are arranged in the same way as the jets in the fixer section. Because of the

small amount of fixer to be removed, fresh water needs to be introduced into the wash section at the low rate of a half-gallon per minute, thus saving water and energy. The high pressure of the water coming out of the fountain jets is supplied by a pump and does not depend on having a high water pressure at the tap.

9. Dryer: As the print leaves the wash chamber, it passes through two transport rollers which also act as squeegee rollers, removing any surface water.

a. The print then enters a clear-water rinse. It is submerged in clear water so that both surfaces get a fresh-water rinse before going to the drying section.

b. Water from the tap enters this rinse chamber first, and as it leaves the rinse tray, it overflows into the wash sump for use in the pressure wash. This double use of the water helps account for the low rate of water consumption by the Royalprint Processor. The countercurrent arrangement, often used in conventional washers set up in stages, provides the freshest water at the last wash stage.

c. As the paper leaves the wash section on its way into the drying section of the processor, it is squeegeed twice by transport rollers and little surface water is left. In the drying section, air at 68 to 71°C (155 to 160°F) is applied to the prints. Because of the water-resistant paper base, only the slight amount of surface water and the water in the emulsion have to be removed. Drying takes place in less than 15 seconds, and the completely dry prints emerge from the processor less than a minute from their entry into the processor.

#### PRACTICE EXERCISE

1. How many steps are there in conventional processing?
2. What does the term developer-incorporated paper mean?
3. What step in the conventional process is considerably shortened when using resin-coated paper?
4. The Kokak Royalprint Processor uses the \_\_\_\_\_ process which makes use of conventional and stabilization processing along with water-resistant and developer-incorporated paper.

## ANSWERS TO PRACTICE EXERCISE

1. Five
2. Developing agents are in the paper emulsion
3. Wash
4. Activation-Conventional