

**OPERATION AND MAINTENANCE
OF
PHOTOGRAPHIC EQUIPMENT**

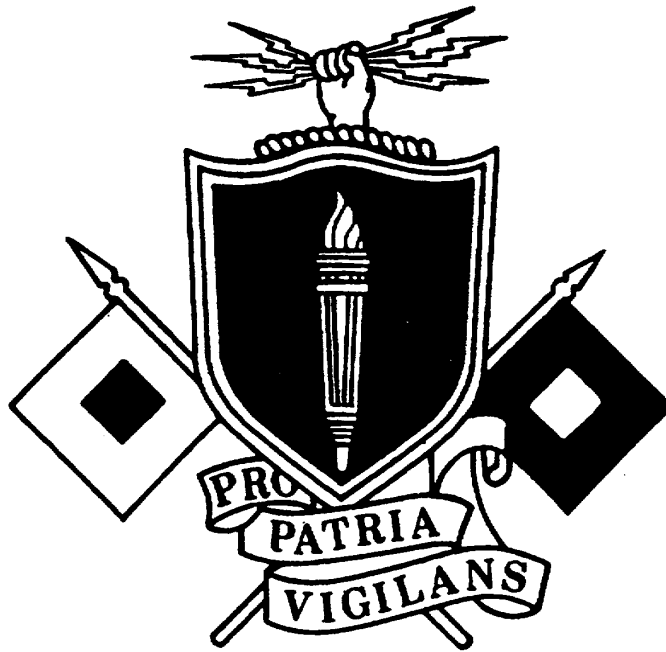

**THE ARMY INSTITUTE FOR PROFESSIONAL DEVELOPMENT
ARMY CORRESPONDENCE COURSE PROGRAM**

**A
I
P
D**

**READINESS /
PROFESSIONALISM**



**THRU
GROWTH**

US ARMY VISUAL INFORMATION/
AUDIO DOCUMENTATION SYSTEMS SPECIALIST
MOS 25S SKILL LEVEL 1

OPERATION AND MAINTENANCE OF
PHOTOGRAPHIC EQUIPMENT

SUBCOURSE NO: SS0522-0

US Army Signal Center and Fort Gordon
Fort Gordon, Georgia

10 Credit Hours

GENERAL

During the time you will be serving in the military as a photographer, whether it will be at the division or Corps Headquarters Photo Facilities, you will be required to operate and maintain your equipment to insure continuous service from you and from the photo section to which you are assigned. So therefore, it is vital that you know how the various types of photographic equipment found throughout the military function, and how to maintain it at the operator's level.

This subcourse will teach you the basic operation and maintenance techniques of the most commonly used equipment with which you might come in contact.

The subcourse is presented in three lessons. The lessons correspond to a learning objective as listed below.

Lesson 1: Operation and Maintenance of Photographic Equipment

TASK: Identify the types of cameras and equipment needing maintenance, their basic operation and operator maintenance procedures required for Still Cameras, Printing Equipment and Finishing Equipment.

CONDITIONS: Given information, illustrations, and procedures on equipment operation and maintenance, and applicable equipment TMs,

STANDARDS: Demonstrate competency of the task skills and knowledge by responding correctly to at least 75 percent of the multiple choice and true or false questions covering the procedures, objectives, techniques for operation and maintenance of photographic equipment.

The objective of this subcourse supports the tasks in STP 11-25S13-SM-TG, published in March 1989, as follows:

- 113-578-5021 Perform Operator's Maintenance of Still Camera(s).
- 113-578-5022 Perform Operator's Maintenance on Projection Printer.
- 113-578-5023 Perform Operator's Maintenance on Print Washer.
- 113-578-5024 Perform Operator's Maintenance on Film Driers.
- 113-578-5026 Perform Operator's Maintenance on Processing Machine EH-91A.
- 113-578-5027 Perform Operator's Maintenance on Darkroom, Photographic, Transportable ES82A.
- 113-578-5028 Perform Operator's Maintenance on Temperature Control Unit, Photographic Processing FH-19A.

NOTE: Any reference to MOS 84B has been changed to MOS 25S effective 1 October 1988.

TABLE OF CONTENTS

Section	Page
TITLE PAGE.....	i
TABLE OF CONTENTS.....	ii
Lesson 1: PHOTOGRAPHIC STILL CAMERAS.....	1
Lesson 2: PHOTOGRAPHIC PRINTING EQUIPMENT.....	134
Lesson 3: PHOTOGRAPHIC FINISHING EQUIPMENT.....	218
ANSWERS TO PRACTICE EXERCISES.....	267

***** IMPORTANT NOTICE *****

THE PASSING SCORE FOR ALL ACCP MATERIAL IS NOW 70%.

PLEASE DISREGARD ALL REFERENCES TO THE 75% REQUIREMENT.

LESSON 1

OPERATION AND MAINTENANCE OF STILL PICTURE CAMERAS

OBJECTIVE:

In this lesson you will learn all the basic functions and operation of the various parts of the following Skill Practice Camera Sets: the KS-7A, KS-17A, and the KS-99C. You will be able to identify each major component and know its function, and have it work together with the rest to make a complete camera.

You will be tested as you go from one section to the next, so that at the end you will be able to pass the examination.

We will not cover anything pertaining to performing photography with this camera, ONLY how the equipment works.

SECTION 1

STILL PICTURE, CAMERA SET KS-7A

1-1 Description of Camera

The camera consists of a camera body, two carriages, a 4" x 5" focusing back, an 8" x 10" focusing back, two front movement mechanisms, two handwheel assemblies, a camera bed, and an easel.

a. Camera body. The camera body includes the following:

(1) A front frame (figure 1) for mounting the lens assembly. The front frame contains a front stationary plate and two front movement plates (horizontal and vertical).

(2) A front bellows (figure 1) and a rear bellows which provide a flexible lighttight compartment (body).

(3) A center frame for securing the bellows in the center of the camera body.

(4) A rear frame for mounting the focusing backs. A clip at each corner of the rear frame provides the means for securing the focusing back to the rear frame.

b. Carriages. The front and rear carriages (figure 1) are castings that are secured to the front and rear frames respectively. The carriages house the camera movement and locking mechanisms, and the slides that ride on the tubular guide rails.

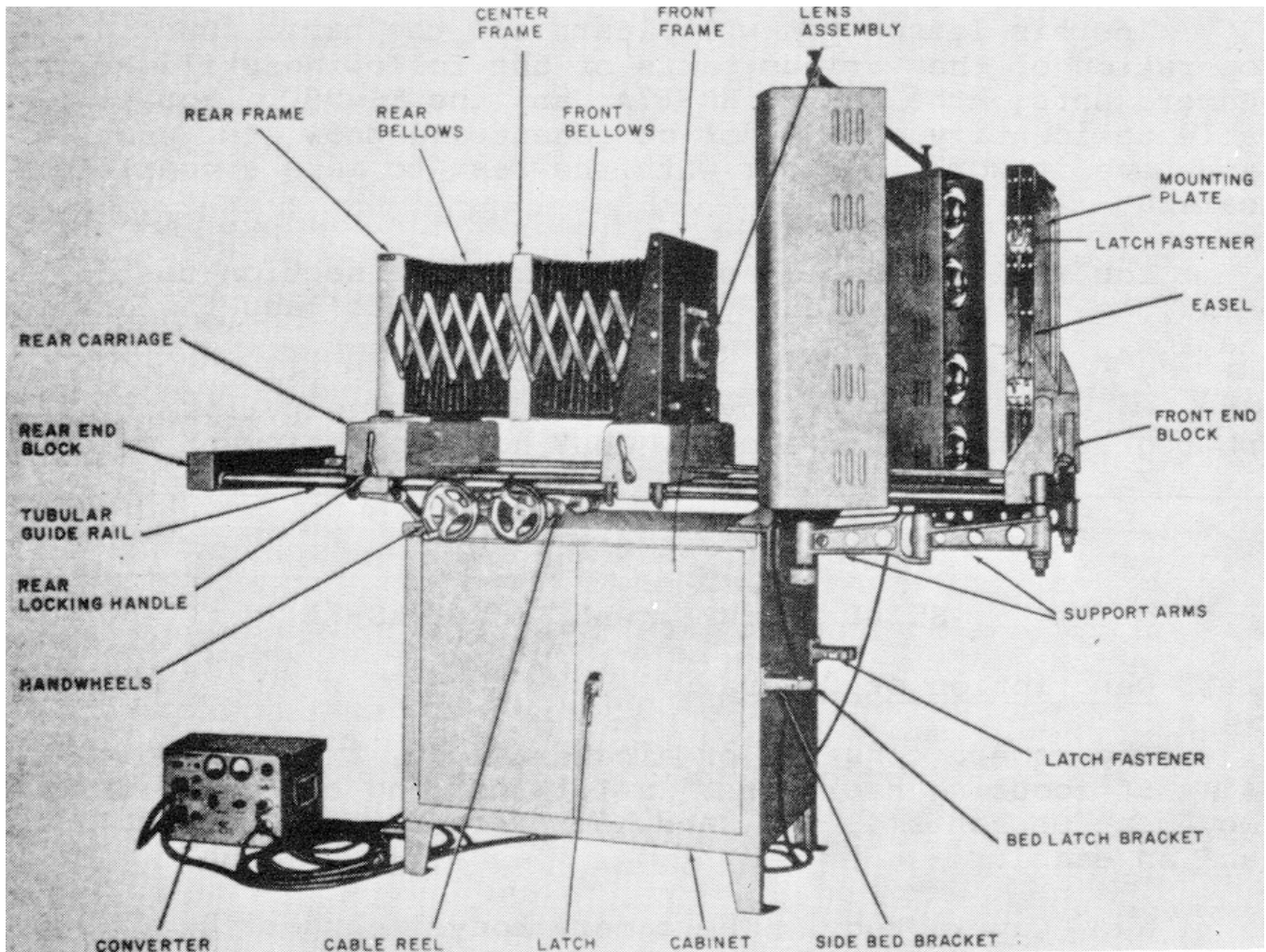

FIGURE 1. Camera set, set up for horizontal operation, right-front view.

c. Camera focusing backs. Two focusing backs are provided with the camera set.

(1) 4" x 5" focusing back. The 4" x 5" focusing back is interchangeable with the 8" x 10" focusing back [(2) below]. The focusing panel shield (figure 2) is secured within the focusing back by two springs. A ground focusing glass is mounted within the focusing panel shield. Horizontal and vertical lines on the ground focusing glass provide a scale to align the image.

(2) 8" x 10" focusing back. The 8" x 10" focusing back is interchangeable with the 4" x 5" focusing back [(1) above]. The focusing panel shield is secured within the focusing back by a screw in each corner. A ground focusing glass is mounted within the focusing panel shield. Horizontal and vertical lines on the ground focusing glass provide a scale to align the image.

d. Front movement mechanisms. The front movement mechanisms provide the facilities for horizontal movement or for the vertical movement of the lens assembly. Each mechanism consists of a guide bar (figure 2) that runs the full length of the carriage bed, a handle grip, and a gear arrangement.

e. Handwheel assemblies. Two handwheel assemblies are provided for movement of the camera carriages. The handwheels (front and rear) (figure 2), through a system of cable reels and wire ropes, move the camera carriages forward and backward as required.

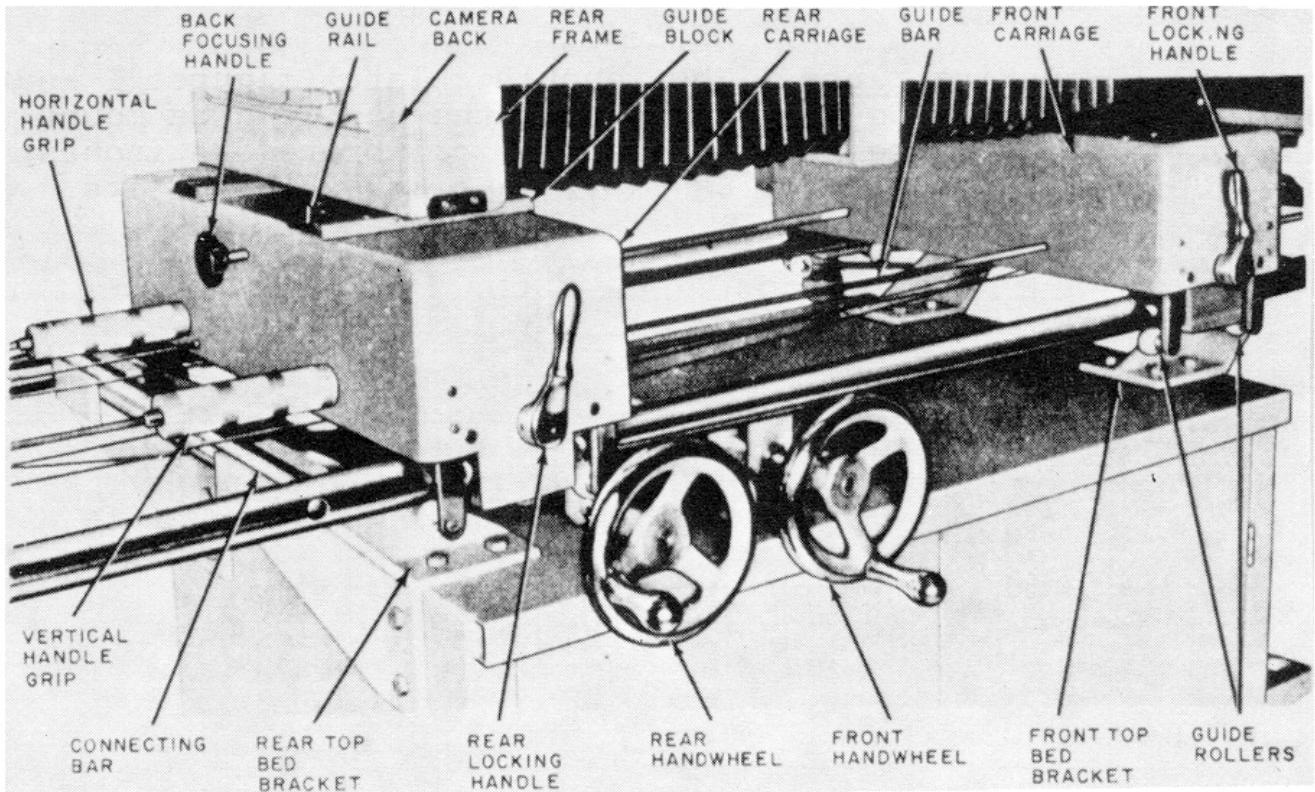

FIGURE 2. Camera, showing location of controls, partial view.

f. Camera bed. The camera bed includes two tubular guide rails (figure 1) with an end block at each end. Wire-rope pulleys are secured to brackets within the end blocks. Two connecting bars between the tubular guide rails provide additional rigidity for the camera bed.

g. Easel. The easel (figures 1 and 3) is hinge-mounted on the front end and includes a blasted glass secured within the easel frame. Five interlocking photographic masks [(1) below] are supplied to hold-copy to the glass frame. Both the glass frame and the masks use clips to secure copy, or the next smaller mask, to the easel. A calibrated mounting plate [(2) below], mounted on a sponge rubber padded mounting board, and two glass plates are also part of the easel.

(1) Masks. Five standard size interlocking masks (figure 3), ranging in masks size from 3 1/4" x 4" through 11" x 14", are used to exclude extraneous light from the camera lens. The large mask can be used by itself to frame an object on the easel. However, when a smaller mask is used, it must be mounted within the next largest mask. Thus, when the smallest mask (3 1/4" x 4") is used, the largest mask must be first mounted on the easel.

(2) Mounting plate. The mounting plate (figures 1 and 3) is used to provide copy support on the easel. The mounting plate has a white imprinted scale, calibrated in inches, and a border imprinted for 8 1/2" x 11" and 8 1/2" x 14" sheets.

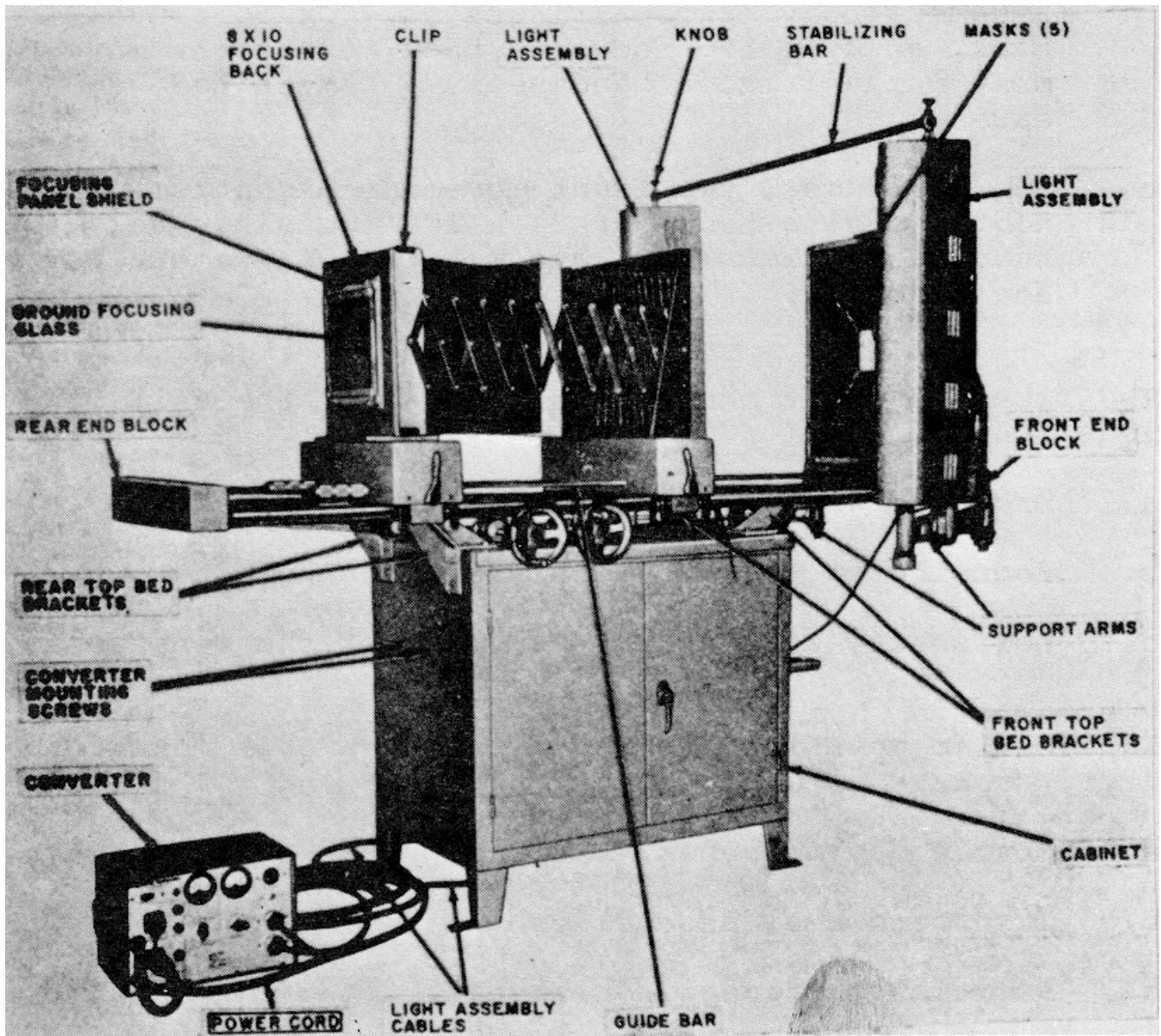

FIGURE 3. Camera set, set up for horizontal operation, right-rear view.

EXERCISE

1. The Camera Set KS-7A consists of which of the following listed major parts?
 - a. two carriages, a 4" x 5" and an 8" x 10" focusing back, two handwheel assemblies, a camera bed, and five easels.

- b. a camera body, two carriages, a 4" x 5" focusing back, an 8" x 10" focusing back, two front movement mechanisms, a handwheel, a camera bed, and an easel.
 - c. two carriages, two front movement mechanisms, a 4" x 5" focusing back, an 8" x 10" focusing back, two handwheel assemblies, a camera bed, a camera body, and an easel.
-

2. The front movement mechanism has one of the following functions:

- a. providing movement of the camera carriages.
 - b. focusing of the image on the focusing glass.
 - c. horizontal and lateral movement of the lens assembly.
-

3. In order to move the camera carriages either forward or backward, you have to do which of the following?

- a. Move the camera bed.
 - b. Turn handwheel assemblies.
 - c. Position the easel horizontal.
 - d. Remove the focusing back.
-

1-2 Description of Cabinet

a. The cabinet (figure 1) is a completely enclosed unit with an adjustable shelf. The doors of the cabinet can be locked close by a latch located on the right-hand door.

b. Two rear top bed brackets (figure 2) and two front top bed brackets, mounted on the cabinet, hold the camera during horizontal operation. During vertical operation, the camera is held by two side bed brackets and the two front top bed brackets and is secured in position by bed latch brackets and latch fasteners (figure 1).

1-3 Description of Lens Assembly (figure 4)

The lens assembly includes a lens, a shutter, a lens board, and a cable release.

a. Lens. The lens is a four-element anastigmatic type XII copying unit. It has a focal length of 12 inches and a maximum aperture of f/6.3. The lens elements are coated to reduce internal reflections.

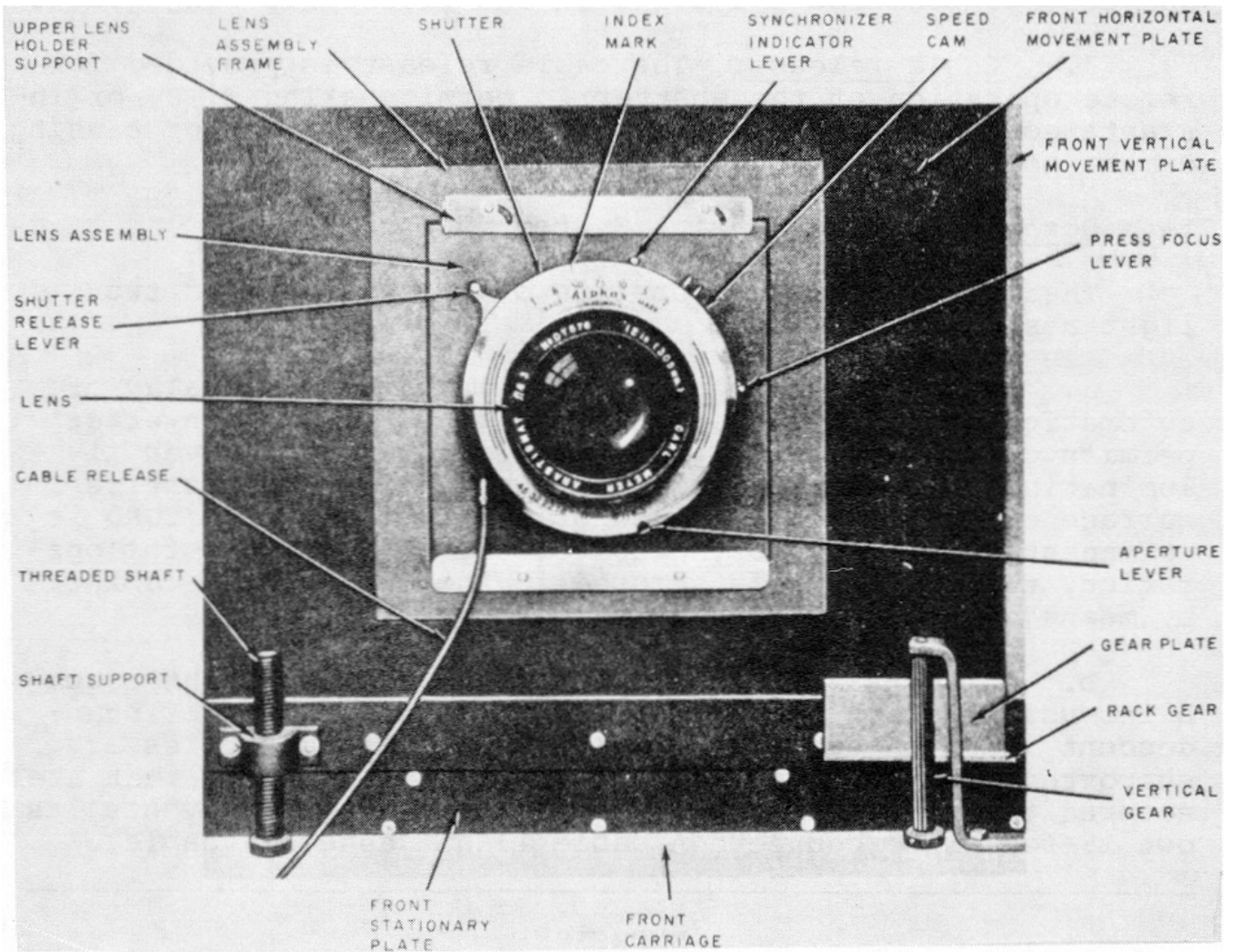

FIGURE 4. Lens assembly mounted in front frame.

b. Shutter. The shutter has five automatically timed speed settings plus time (T), bulb (B), and seven aperture settings. The shutter also contains an internal synchronization mechanism and a press focus lever to open and close the shutter to facilitate focusing.

c. Lens board. The lens board is provided to permit mounting the lens assembly in the front frame of the camera. The front vertical movement plate with the threaded shaft and shaft support, and the front horizontal movement plate with the vertical gear and rack gear shift the lens board and lens to position the image on the ground focusing glass.

d. Cable release. The cable release is provided for remote operation of the shutter to permit making T, B, or instantaneous (I) exposures without jarring the lens or causing camera movement.

1-4 Description of Lighting System (figure 3)

The lighting system consists of a converter and two light assemblies.

a. Converter. The converter is used to manually or automatically operate the light assemblies. The converter permits control of the light assemblies to obtain even illumination and balanced color temperature over the entire surface of the easel. One end of the 20-foot POWER CORD is permanently attached to the converter. When set up for operation, the converter is secured to the rear of the cabinet by means of two converter mounting screws.

b. Light assemblies (figure 3). The two light assemblies use standard incandescent lamps (four 150-watt incandescent lamps in each assembly). The light assemblies are supported by a carriage assembly (two support arms) that are secured to the front end block. Each light assembly has its own 15-foot interconnection cable (light assembly cable).

EXERCISE

4. The lens assembly includes the following items: _____

(complete sentence)

5. What is the focal length of the lens and the maximum f/stop?

ANS: _____, _____

6. There are _____ automatically timed speed settings plus () and () settings and _____ aperture settings.
(fill-in blanks)

7. What is the wattage of the incandescent lamps used with the light assemblies?

ANS: _____

1-5 Description of Minor Components

a. Ground focusing glass. The 4" x 5" focusing back and the 8" x 10" focusing back (para 1-1c) are provided with a 4" x 5" ground focusing glass and an 8" x 10" ground focusing glass, respectively. When either of the focusing backs is installed on the camera, the ground focusing glass is positioned in the focal plane to permit focusing the image from the lens and to define the picture area.

b. Filmholders. Six 4" x 5" filmholders and six 8" x 10" filmholders are furnished with the camera set. During operation, a loaded filmholder is inserted in the focusing back. The film is positioned in the film plane to second the image after it has been sharply focused on the ground focusing glass (a above).

c. Filter holder. The filter holder positions standard 4" x 5" photographic filters in front of the camera lens. The filter is used when it is necessary to alter the film spectral response.

d. Opal glass. The opal glass provides even illumination when transparencies or other materials that are illuminated from the rear, are being copied.

e. Camel's hair brush. The camel's hair brush is used for removing dust from the glass parts of the camera set. The brush is contained within its own metal case.

f. Spanner wrench. The spanner wrench is provided only for use by higher echelon personnel. The spanner wrench has an 11 1/4" jaw and a 9/32" tooth. The spanner wrench is stored in the cabinet and is used to tighten the light assemblies in place on the support arms.

EXERCISE

8. When copying a transparency, which must have an even illumination, you should use the _____.
(complete statement)

9. When using a photographic filter in copying with the KS-7A, it should be placed where on the camera?

ANS: _____

SECTION 2

STILL PICTURE, CAMERA SET KS-7A

CONTROLS, INDICATORS, AND CONNECTORS

NOTE: Paragraphs 1-6 through 1-8 cover only items used by the operator; items used by maintenance personnel are covered in instructions for the appropriate maintenance echelon.

2-1 Camera Controls (figure 5)

Control	Function
Front handwheel.....	Image size adjustment. Rotating front handwheel clockwise moves camera toward easel to increase image size. Rotating front handwheel counterclockwise moves camera away from easel to decrease image size.
Rear handwheel.....	Course focus adjustment. Rotating rear handwheel clockwise moves rear carriage toward front frame to decrease bellows extension. Rotating rear handwheel counterclockwise moves rear carriage away from front frame to increase bellows extension.
Front locking handles.....	Two-position levers:

NOTE: A locking handle is located at each end of the front carriage.

<u>Position</u>	<u>Function</u>
Forward.....	Lock front carriage to tubular guide rails.
Backward.....	Unlock front carriage from tubular guide rails.

Control	Function						
Rear locking handles.....	Two-position levers:						
<u>NOTE:</u> A locking is located at each end of rear carriage.	<table border="1"> <thead> <tr> <th data-bbox="821 352 966 380"><u>Position</u></th> <th data-bbox="1060 352 1205 380"><u>Function</u></th> </tr> </thead> <tbody> <tr> <td data-bbox="821 420 966 447">Forward.....</td> <td data-bbox="1060 420 1485 483">Lock rear carriage to tubular guide rails.</td> </tr> <tr> <td data-bbox="821 520 966 548">Backward.....</td> <td data-bbox="1060 520 1485 615">Unlock rear carriage from tubular guide rails.</td> </tr> </tbody> </table>	<u>Position</u>	<u>Function</u>	Forward.....	Lock rear carriage to tubular guide rails.	Backward.....	Unlock rear carriage from tubular guide rails.
<u>Position</u>	<u>Function</u>						
Forward.....	Lock rear carriage to tubular guide rails.						
Backward.....	Unlock rear carriage from tubular guide rails.						
Vertical handle grip.....	Controls vertical movement of lens assembly:						
	<table border="1"> <thead> <tr> <th data-bbox="821 751 1031 814">Direction of rotation</th> <th data-bbox="1240 751 1385 779">Function</th> </tr> </thead> <tbody> <tr> <td data-bbox="821 852 1031 879">Clockwise.....</td> <td data-bbox="1240 852 1485 947">Moves lens assembly downward.</td> </tr> <tr> <td data-bbox="821 984 1031 1012">Counterclockwise.....</td> <td data-bbox="1240 984 1485 1083">Moves lens assembly upward.</td> </tr> </tbody> </table>	Direction of rotation	Function	Clockwise.....	Moves lens assembly downward.	Counterclockwise.....	Moves lens assembly upward.
Direction of rotation	Function						
Clockwise.....	Moves lens assembly downward.						
Counterclockwise.....	Moves lens assembly upward.						
Horizontal handle grip.....	Controls horizontal movement of lens assembly:						
	<table border="1"> <thead> <tr> <th data-bbox="821 1220 1031 1283">Direction of rotation</th> <th data-bbox="1240 1220 1385 1247">Function</th> </tr> </thead> <tbody> <tr> <td data-bbox="821 1320 1031 1348">Clockwise.....</td> <td data-bbox="1240 1320 1485 1415">Moves lens assembly to the left.</td> </tr> <tr> <td data-bbox="821 1453 1031 1480">Counterclockwise.....</td> <td data-bbox="1240 1453 1485 1551">Moves lens assembly to the right.</td> </tr> </tbody> </table>	Direction of rotation	Function	Clockwise.....	Moves lens assembly to the left.	Counterclockwise.....	Moves lens assembly to the right.
Direction of rotation	Function						
Clockwise.....	Moves lens assembly to the left.						
Counterclockwise.....	Moves lens assembly to the right.						

Control

Function

Back focusing handle.....Fine focus adjustment:

Direction of rotation

Function

Clockwise.....Moves camera back away from lens assembly.

Counterclockwise.....Moves camera back toward lens assembly.

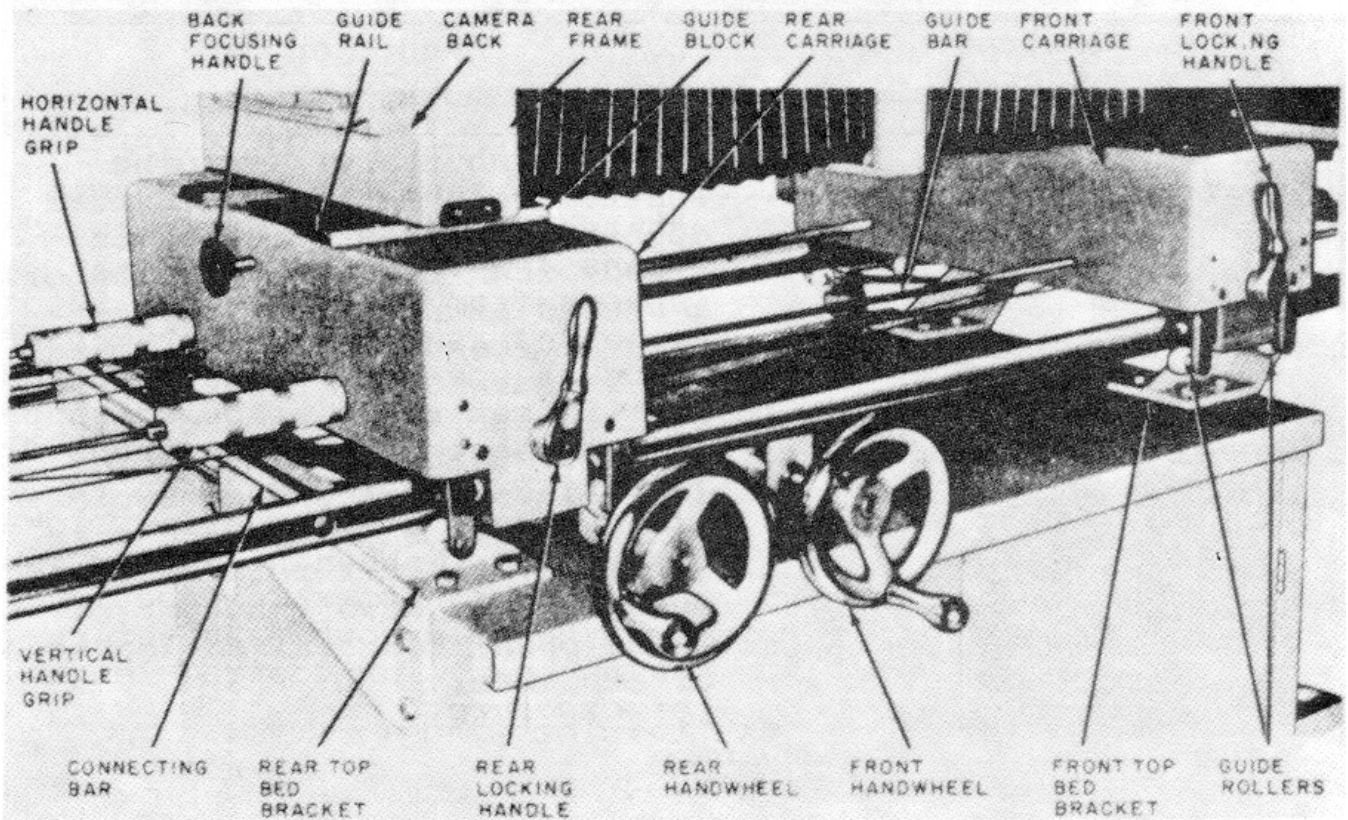

FIGURE 5. Camera, showing location of controls, partial view.

EXERCISE

10. The two handwheels control what portion of the camera operation on the KS-7A Camera Set?

ANS: _____

11. The lateral and vertical movement of the image on the ground glass is controlled by the _____ and _____. (complete sentence)

12. In order to fine focus an image on the ground glass, how must you make your adjustment?

ANS: _____

2-2 Lens Assembly Controls (figure 6)

Control	Function
Shutter release lever.....	Operates shutter. Tripping shutter release lever downward opens and closes shutters in speeds from 1/2 through 1/50 of a second as determined by setting of speed cam. When speed cam is set to T, tripping shutter release lever once opens shutter; tripping shutter release lever a second time closes shutter. When speed cam is set to B, shutter release lever must be held down (shutter remains open) for desired length of exposure.

Control	Function
---------	----------

Synchronizer indicator lever.....Flash circuit adjustment control:

Position	Function
X (left).....	Synchronizes shutter with electronic flash.
M (right).....	Synchronizes shutter for medium peak flash.

Speed cam (circular disk).....Shutter speed adjustment control:

Position	Function
2.....	Sets shutter speed at 1/2 second.
5.....	Sets shutter speed at 1/5 second.
10.....	Sets shutter speed at 1/10 second.
25.....	Sets shutter speed at 1/25 second.
50.....	Sets shutter speed at 1/50 second.

Control	Function						
	<table border="1"> <thead> <tr> <th>Position</th> <th>Function</th> </tr> </thead> <tbody> <tr> <td>T.....</td> <td>Sets up shutter for double tripping operation (first for opening and second for closing).</td> </tr> <tr> <td>B.....</td> <td>Sets up shutter for exposures longer than 1/2 second.</td> </tr> </tbody> </table>	Position	Function	T.....	Sets up shutter for double tripping operation (first for opening and second for closing).	B.....	Sets up shutter for exposures longer than 1/2 second.
Position	Function						
T.....	Sets up shutter for double tripping operation (first for opening and second for closing).						
B.....	Sets up shutter for exposures longer than 1/2 second.						
Press focus lever.....	Shutter opening (for focusing control:						
	<table border="1"> <thead> <tr> <th>Position</th> <th>Function</th> </tr> </thead> <tbody> <tr> <td>Down.....</td> <td>Opens shutter for focusing; latches open until released manually.</td> </tr> <tr> <td>Up.....</td> <td>Closes shutter.</td> </tr> </tbody> </table>	Position	Function	Down.....	Opens shutter for focusing; latches open until released manually.	Up.....	Closes shutter.
Position	Function						
Down.....	Opens shutter for focusing; latches open until released manually.						
Up.....	Closes shutter.						
Aperture lever.....	Aperture size adjustment control. Moving lever to left (towards f/45) decreases aperture size. Moving lever to right (towards f/6.3) increases aperture size.						
Cable release.....	Plunger (not shown) on end of cable release used to operate shutter in same manner as shutter release lever.						

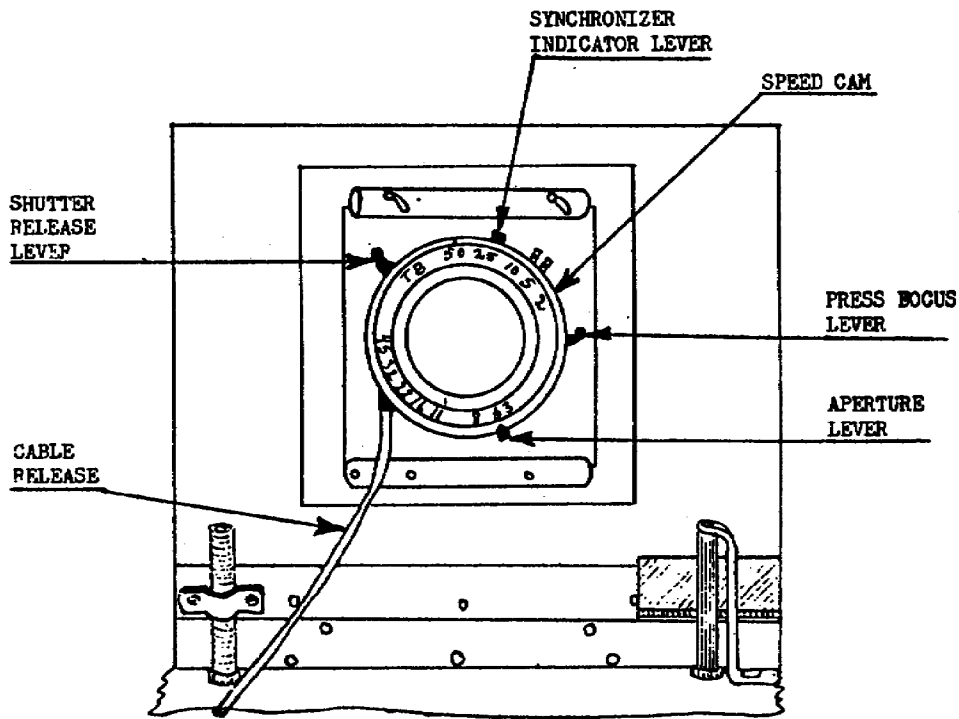

FIGURE 6. Lens assembly controls.

EXERCISE

13. The lens for the KS-7A Camera has two synchronizer positions "M" and "X". What position controls what type of synchronization?

"M" - _____

"X" - _____

(Fill in)

14. Which shutter speed selection should you use if your selected exposure time is 15 seconds?

ANS: _____

15. What is the function of the aperture lever?

ANS: _____

2-3 Converter Controls, Indicators, and Connectors (figure 7)

Control, Indicator or Connector	Function						
MAIN POWER switch.....	Dpst toggle switch: <table border="0"> <thead> <tr> <th data-bbox="803 655 950 682">Position</th> <th data-bbox="1047 655 1193 682">Function</th> </tr> </thead> <tbody> <tr> <td data-bbox="803 724 950 751">ON.....</td> <td data-bbox="1047 724 1485 787">Applies power to converter.</td> </tr> <tr> <td data-bbox="803 829 950 856">OFF.....</td> <td data-bbox="1047 829 1485 892">Disconnects power from converter.</td> </tr> </tbody> </table>	Position	Function	ON.....	Applies power to converter.	OFF.....	Disconnects power from converter.
Position	Function						
ON.....	Applies power to converter.						
OFF.....	Disconnects power from converter.						
Pilot light.....	Neon indicator; lights when MAIN POWER switch is set to ON.						
Ammeter.....	0- to 30-ampere range; indicates amount of current being drawn by converter.						
<u>NOTE:</u> Indication should not exceed 30 amperes when power source is low voltage (105-125V ac) or 15 amperes when power source is high voltage (210-230V ac).							
Kelvin meter.....	Dual scale ac voltmeter; indicates converter output voltage and related color temperature, in degrees Kelvin, that light assemblies produce.						

Control, Indicator or Connector	Function
------------------------------------	----------

Interval timer receptacle.....Two-prong female receptacle; permits connection of interval timer.

MANUAL-TIMER switch.....Dpdt toggle switch:

Position	Function
----------	----------

Manual

Operation....Sets up converter output to be controlled (on or off) by MAIN POWER switch.

NOTE: Lamps will operate only at voltage selected by KELVIN TEMPERATURE SELECTOR switch.

Remote Timer

Operation....Sets up converter output to be low or to be controlled by interval timer.

NOTE: If interval timer is not used, lamps will operate at reduced voltage until switch is set to MANUAL OPERATION. If interval timer is used, lamps will operate at reduced voltage until interval timer operates. Then, lamps will operate at voltage selected by KELVIN TEMPERATURE SELECTOR switch. When

Control, Indicator
or Connector

Function

cycle of interval timer is
over, lamps will again
operate at reduced voltages.

KELVIN TEMPERATURE

SELECTOR switch.....7-position ROTARY switch:

Position	Function
1.....	Selects output of 120V ac at 2900° K.
2.....	Selects output of 131V ac at 2992° K.
3.....	Selects output of 142V ac at 3084° K.
4.....	Selects output of 153V ac at 3176° K.
5.....	Selects output of 164V ac at 3268° K.
6.....	Selects output of 175V ac at 3360° K.
7.....	Selects output of 186V ac at 3450° K.

NOTE: The above outputs are based
on an input voltage of 115V
ac.

Control, Indicator or Connector	Function																
Output Receptacle (2).....	Permit connection of cables from light assemblies to converter.																
INPUT VOLTAGE SELECTOR																	
switch.....	6-position ROTARY switch:																
	<table border="0"> <thead> <tr> <th data-bbox="808 489 951 514">Position</th> <th data-bbox="1049 489 1190 514">Function</th> </tr> </thead> <tbody> <tr> <td data-bbox="808 556 1000 613">105V, 115V, or 125V.....</td> <td data-bbox="1049 590 1481 709">Sets up converter to operate off low voltage (105V ac through 125V ac input).</td> </tr> <tr> <td data-bbox="142 751 792 777">INPUT VOLTAGE SELECTOR</td> <td></td> </tr> <tr> <td data-bbox="142 783 792 808">switch.....</td> <td data-bbox="808 783 1481 947"> <table border="0"> <tbody> <tr> <td data-bbox="808 783 1000 840">210V, 220V, or 230V.....</td> <td data-bbox="1049 821 1481 940">Sets up converter to operate off high voltage (210V ac through 230V ac input).</td> </tr> </tbody> </table> </td> </tr> <tr> <td></td> <td data-bbox="857 989 1481 1079"> <p><u>NOTE:</u> Switch is set to position which most nearly matches input voltage.</p> </td> </tr> <tr> <td data-bbox="142 1121 792 1146">105/125V ac receptacle.....</td> <td data-bbox="808 1121 1481 1241">When INPUT CORD is connected to 105/125V ac receptacle, converter is set up to operate off low voltage input.</td> </tr> <tr> <td data-bbox="142 1289 792 1314">210/230V ac receptacle.....</td> <td data-bbox="808 1289 1481 1409">When INPUT CORD is connected to 210/230V ac receptacle, converter is set up to operate off high voltage input.</td> </tr> </tbody> </table>	Position	Function	105V, 115V, or 125V.....	Sets up converter to operate off low voltage (105V ac through 125V ac input).	INPUT VOLTAGE SELECTOR		switch.....	<table border="0"> <tbody> <tr> <td data-bbox="808 783 1000 840">210V, 220V, or 230V.....</td> <td data-bbox="1049 821 1481 940">Sets up converter to operate off high voltage (210V ac through 230V ac input).</td> </tr> </tbody> </table>	210V, 220V, or 230V.....	Sets up converter to operate off high voltage (210V ac through 230V ac input).		<p><u>NOTE:</u> Switch is set to position which most nearly matches input voltage.</p>	105/125V ac receptacle.....	When INPUT CORD is connected to 105/125V ac receptacle, converter is set up to operate off low voltage input.	210/230V ac receptacle.....	When INPUT CORD is connected to 210/230V ac receptacle, converter is set up to operate off high voltage input.
Position	Function																
105V, 115V, or 125V.....	Sets up converter to operate off low voltage (105V ac through 125V ac input).																
INPUT VOLTAGE SELECTOR																	
switch.....	<table border="0"> <tbody> <tr> <td data-bbox="808 783 1000 840">210V, 220V, or 230V.....</td> <td data-bbox="1049 821 1481 940">Sets up converter to operate off high voltage (210V ac through 230V ac input).</td> </tr> </tbody> </table>	210V, 220V, or 230V.....	Sets up converter to operate off high voltage (210V ac through 230V ac input).														
210V, 220V, or 230V.....	Sets up converter to operate off high voltage (210V ac through 230V ac input).																
	<p><u>NOTE:</u> Switch is set to position which most nearly matches input voltage.</p>																
105/125V ac receptacle.....	When INPUT CORD is connected to 105/125V ac receptacle, converter is set up to operate off low voltage input.																
210/230V ac receptacle.....	When INPUT CORD is connected to 210/230V ac receptacle, converter is set up to operate off high voltage input.																

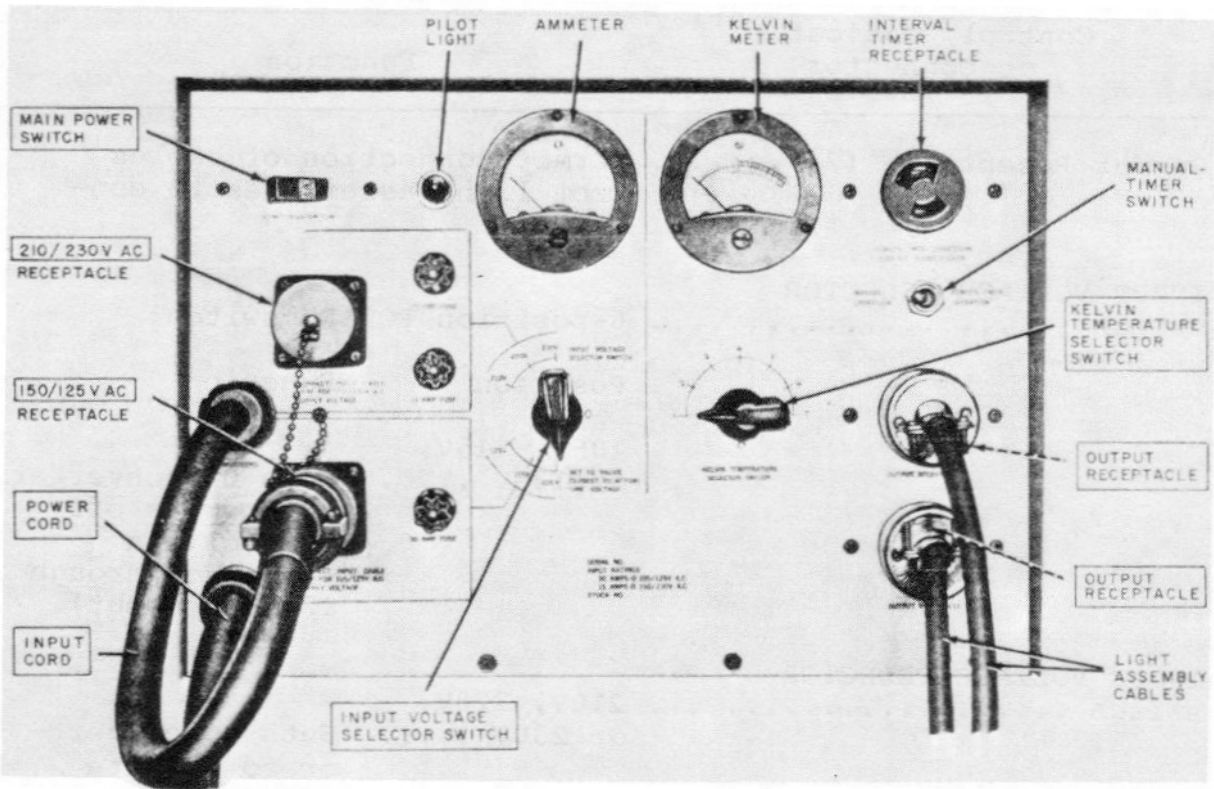

FIGURE 7. Converter, showing location of controls, indicators, and connectors, front view.

EXERCISE

16. The pilot light on the converter, when glowing tells you that the

(complete statement)

17. In order to set the Kelvin meter to the correct Kelvin temperature, which of the following controls should you use?
(circle best answer)

- a. INPUT VOLTAGE SELECTOR switch.
- b. MANUAL-TIMER switch.
- c. KELVIN TEMPERATURE SELECTOR switch.
- d. MAIN POWER switch.

18. The INPUT VOLTAGE SELECTOR switch has how many variable voltage selector positions? (circle one)

- a. 5 b. 8 c. 7 d. 6
-

19. "0- to 30-ampere range; indicates amount of current being drawn by converter."

The above statement explains the function of one of the following items:

- a. Ammeter.
b. Pilot light.
c. MAIN POWER switch.
d. Kelvin meter.
-

2-4 Loading of Filmholders

To load the 4" x 5" filmholders, follow the procedures in a below. To load the 8" x 10" filmholders, follow the procedures in b below.

CAUTION: The film loading procedures must be performed in a photographic darkroom. Loading the filmholders in other than total darkness will ruin the film. Be sure to read and understand the loading procedures (a or b below) before attempting to load the holders.

a. Loading the 4" x 5" filmholders (figure 8). The following procedures apply to each of the 4" x 5" filmholders.

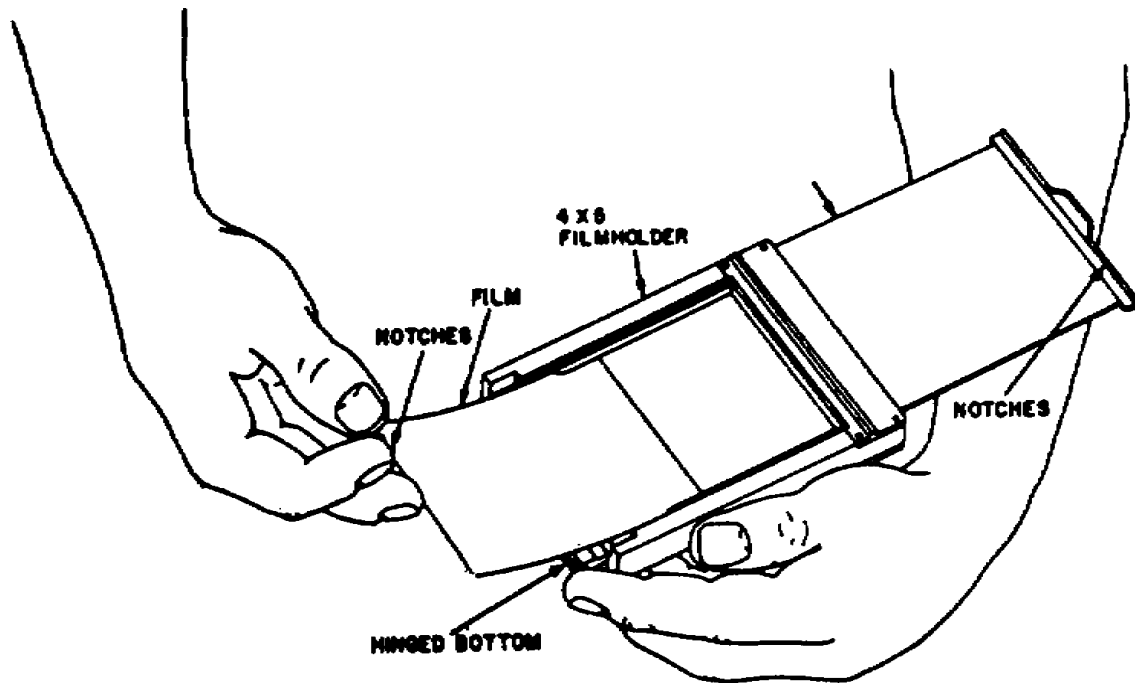

FIGURE 8. Loading 4" x 5" filmholder.

- (1) Pull out the slide and partially reinsert it in the filmholder. Make sure that the bright side of the slide (notches) faces out.
- (2) Open the hinged bottom of the filmholder. Hold the hinged bottom open with the left hand and the film in the right hand, with the forefinger on the notches. Make sure that the notches are in the position as shown, so that the emulsion (dull) side will face up.
- (3) Slide the film into the grooves, along the sides of the filmholder, until it is fully inserted. Close the hinged bottom.
- (4) Insert the slide completely into the filmholder and into the hinged bottom.
- (5) Lift the locking screw (not shown) to hold the slide in position.
- (6) Turn the filmholder over and load the opposite side by repeating the procedures in (1) through (5) above.

b. Loading 8" x 10" filmholders (figure 9). The following procedures apply to each of the 8" x 10" filmholders.

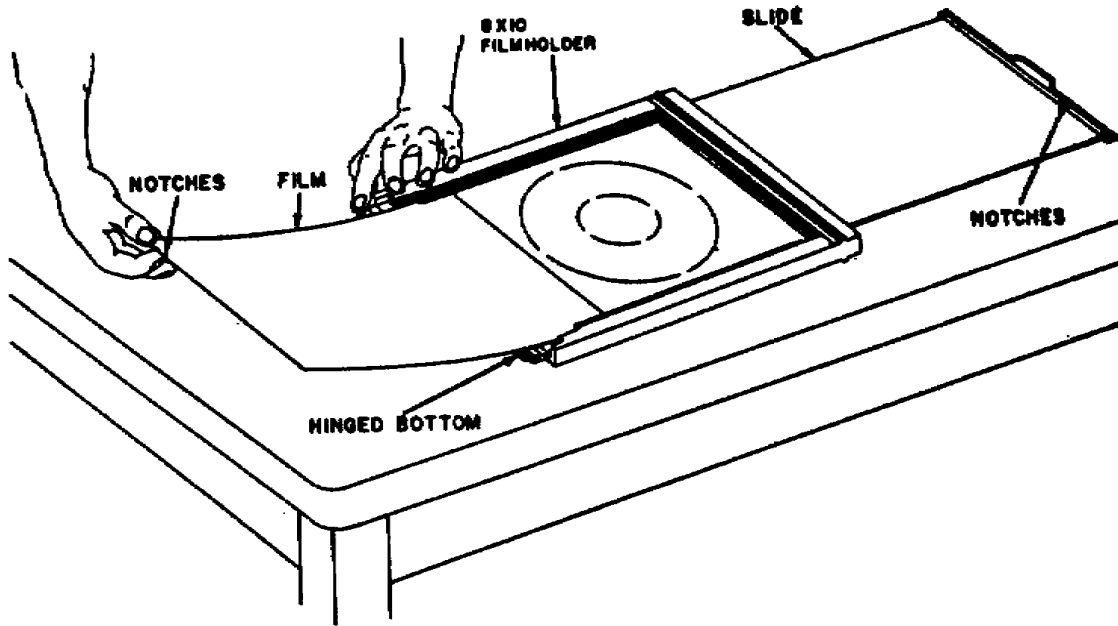

FIGURE 9. Loading 8" x 10" filmholder.

- (1) Place the filmholder on a clean work surface.
- (2) Follow the procedures in a(1) through (6) above.

EXERCISE

20. When following prescribed loading steps of a cut filmholder, where are the notches on the film located when you insert the film into the filmholder?

- a. Upper right-hand corner.
 - b. Lower right-hand corner.
 - c. Lower left-hand corner.
 - d. None of the above.
-

2-5 Preparing Lighting System

To prepare the lighting system for operation, first adjust the output converter (a below) and then adjust the position of the light assemblies (b below).

a. Converter (figure 10). Prepare the converter for operation as follows:

(1) Check to be sure that the MAIN POWER switch is set to OFF.

(2) Check to be sure that the POWER CORD is connected to the source of power and that the INPUT VOLTAGE SELECTOR switch is set to the position that most nearly matches the voltage of the power source.

NOTE: The value of the voltage at the power source will have been marked on the output receptacle at the time the camera set was installed by higher echelon personnel.

(3) Set the MANUAL-TIMER switch to REMOTE TIMER OPERATION.

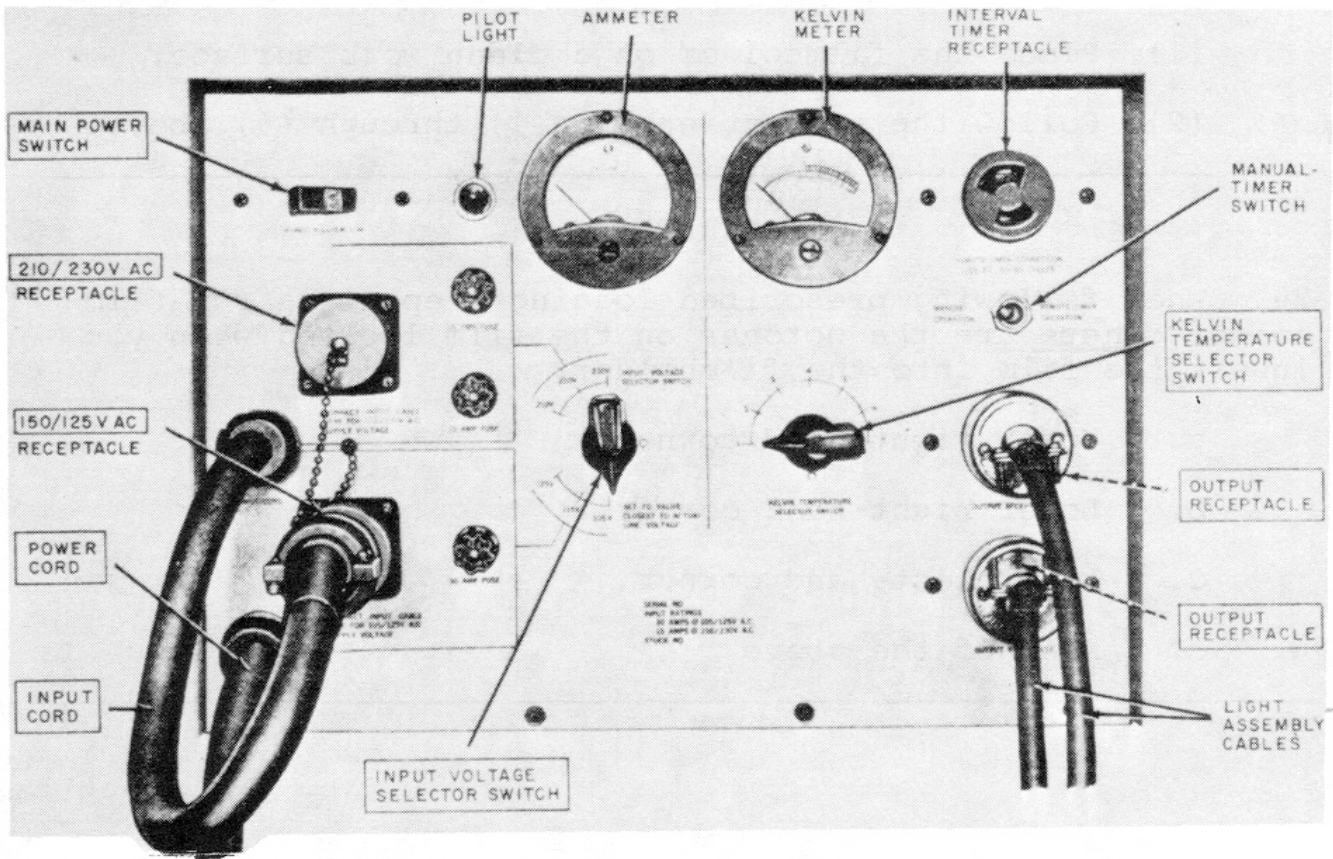

FIGURE 10. Converter, showing location of controls, indicators, and connectors, front view.

(4) Set the MAIN POWER switch to ON; the pilot light will glow and the lamps in the light assemblies will glow dimly.

(5) Set the KELVIN TEMPERATURE SELECTOR switch to 1.

(6) Set the MANUAL-TIMER switch to MANUAL OPERATION; the lamps in the light assembly will glow more brightly.

(7) Adjust the KELVIN TEMPERATURE SELECTOR switch to the position at which the Kelvin meter indicates the desired color temperature.

b. Light assemblies. The light assemblies can be positioned either in front of the easel or in back of the easel. Adjust the position of the light assemblies as follows:

(1) Loosen the knob located on the outside of the top of each light assembly.

(2) Remove the stabilizing bar from the stabilizing bar brackets.

(3) Swing the light assemblies (mounted on the support arms) to the front of the easel for copying opaque material, or to the back of the easel for copying transparent material.

(4) Align the light assemblies so that even illumination is obtained on the easel.

(5) Loosen the knobs located inside the top of each light assembly and align the stabilizing bar brackets.

(6) Install the stabilizing bar in the stabilizing bar brackets and tighten the knobs (both inside and outside the light assemblies).

EXERCISE

21. When you prepare the converter for operation, the first thing you must do is to _____.

(complete statement)

22. Which of the following operations will cause the light assemblies to glow dimly?

- a. Set KELVIN TEMPERATURE switch to #1.
 - b. Set MANUAL-TIMER switch to REMOTE TIMER OPERATION.
 - c. Set MAIN POWER switch to ON.
 - d. Set MAIN POWER switch to OFF.
-

2-6 Loading Easel Horizontal Operation

For horizontal operation, the easel can be loaded with standard size rigid copy (a below), with nonstandard size or nonrigid copy (b below), or with a negative or a colored transparency (c below).

a. Standard size rigid copy. To load the easel with standard size rigid copy, proceed as follows:

(1) Select the mask that matches the size of the copy. Mask sizes available (figure 11) are 3 1/4" x 4", 4" x 5", 5" x 7", 8" x 10", and 11" x 14".

(2) Secure the mask (or masks) to the front of the easel (figure 12).

(3) Secure the copy within the mask with the clips provided at the corners.

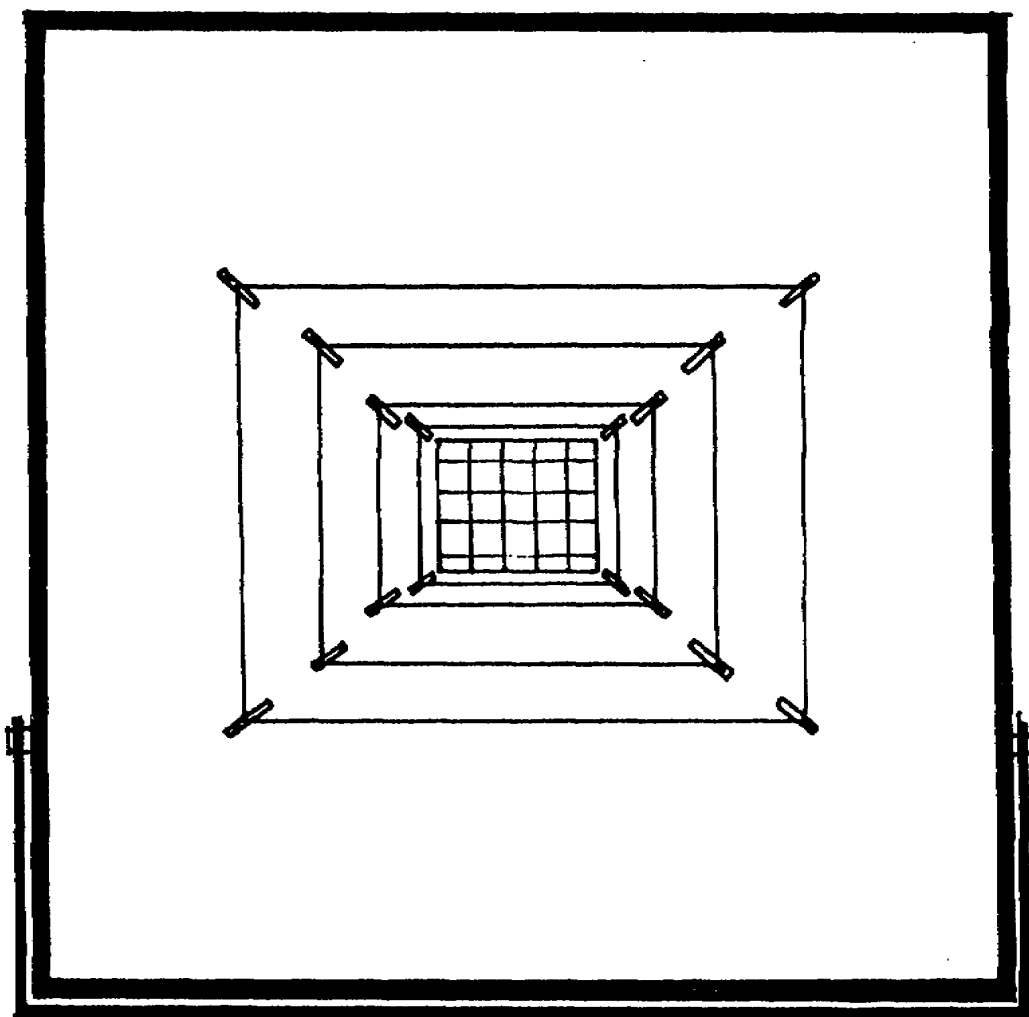

FIGURE 11. Easel, with the five standard masks in place.

b. Nonstandard size or nonrigid copy. To load the easel with nonstandard size or nonrigid copy, proceed as follows:

- (1) Tip the easel (figure 12) to the right (horizontal position).
- (2) Release the latch fasteners and open the easel.
- (3) Place the copy over the scale on the mounting plate, or within the border lines as necessary.
- (4) Close the easel and secure the latch fasteners.
- (5) Raise the easel to the vertical position.

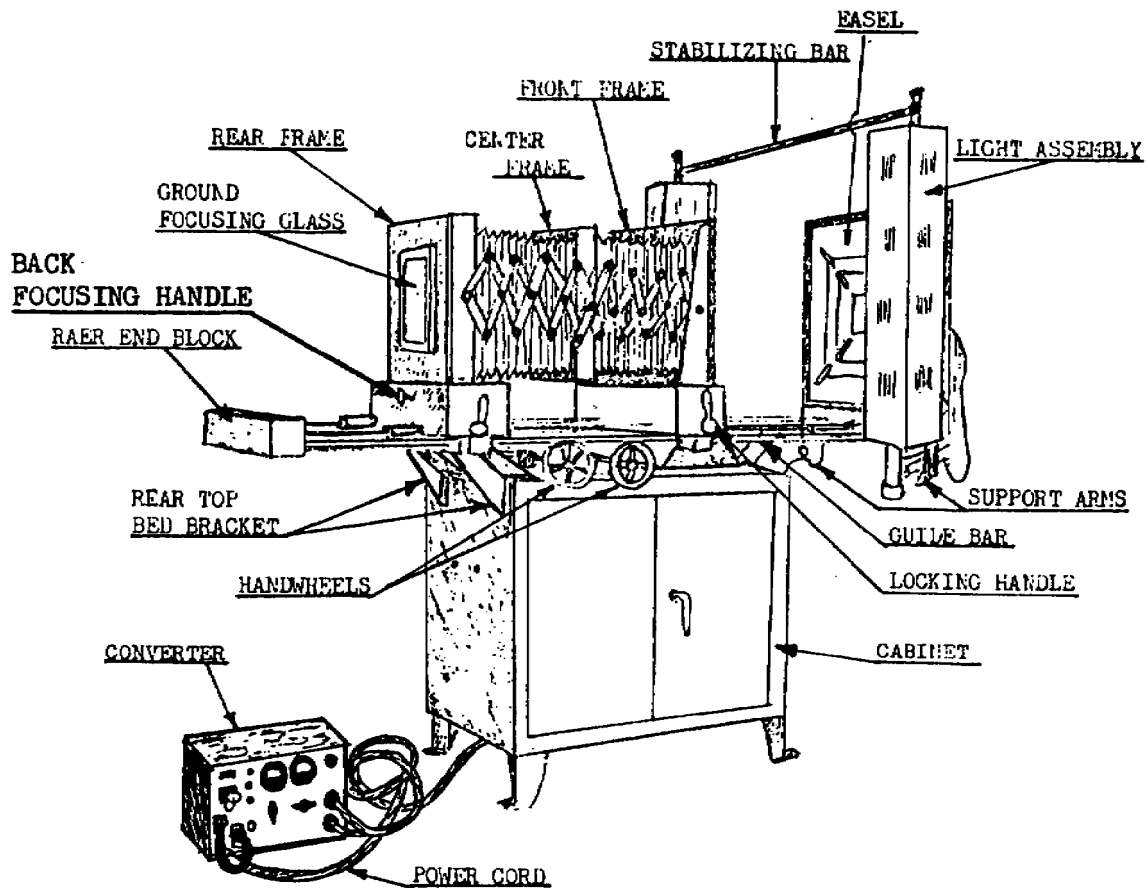

FIGURE 12. Camera set, set up for horizontal operation, right-rear view.

c. Negative or colored transparency. To load the easel with a negative or colored transparency of a standard size, follow the procedures in (1) below. To load the easel with a negative or colored transparency that is not of a standard size, follow the procedures in (2) below.

(1) Standard size.

(a) Release the latch fasteners, open the easel, and remove the plate and the sponge rubber padded mounting board.

(b) Close the easel and secure the latch fasteners.

(c) Install the opal glass in the rear of the easel; use the easel corner clips.

(d) Secure the negative or colored transparency to the front of the easel with the photographic mask or masks (a above).

(2) Nonstandard size.

(a) Follow the procedures in (1)(a) and (b) above.

(b) Install the opal glass in the front of the easel; use the easel corner clips.

(c) Tape the negative or colored transparency directly to the opal glass.

EXERCISE

23. The easel has five different masks sizes. Identify the five mask sizes.

ANS: _____, _____, _____, _____,
and _____.

24. The three types of material that can be mounted on the easel are

SECTION 3

STILL PICTURE, CAMERA SET KS-7A

OPERATING INSTRUCTIONS

3-1 Setting Up Camera Set

Set up the camera set for operation as follows:

- a. Load the filmholders (4" x 5" or 8" x 10") that will be required (para 2-4a or b).
 - b. Load the easel with the object (para 2-6a and b).
 - c. Install the 4" x 5" or the 8" x 10" focusing back to accommodate the required filmholders (4" x 5" or 8" x 10").
 - d. Prepare the converter (para 2-5a) and the light assemblies (para 2-5b) for operation.
-

3-2 Adjusting Size and Focusing

The camera set will produce copies the same size as the original, enlargements of the original, or reductions of the original. The following procedures may be used to obtain the required size.

- a. Remove the lens cap from the front of the lens (figure 13).
- b. Set the aperture lever (figure 13) to f/6.3. This setting will admit the maximum amount of light and produce the minimum depth of field for sharp focusing.
- c. Press down on the press focus lever. The shutter will open and remain open to permit focusing.

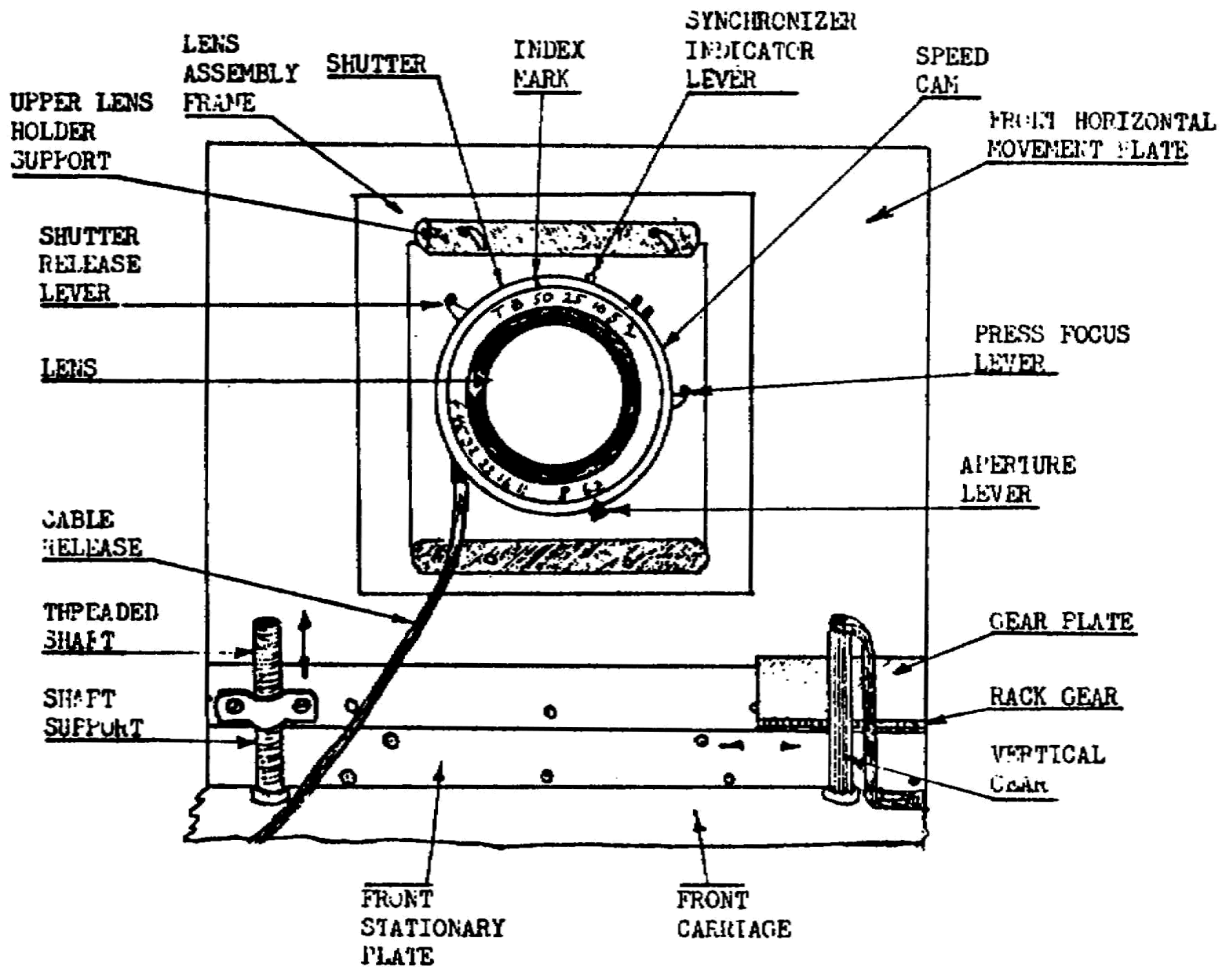

FIGURE 13. Lens assembly mounted in front focus

d. Move the locking handles on the carriages backward to release the carriages (figure 14).

e. Rotate the front handwheel (clockwise or counterclockwise as required) until the image on the ground focusing glass (figure 14) is approximately the size desired.

NOTE: The size of the image can be estimated by using the lines on the ground focusing glass as a guide. The distance between the lines on the 8" x 10" focusing back is 1/2 inch. The distance between the lines on the 4" x 5" focusing back is 1/4 inch. The image dimensions can range from one-quarter to four times the dimensions of the object being copied. Moving the

lens toward the object increases image size, while moving the lens away from the object decreases image size. Maximum reduction is obtained with an object-to-lens distance of approximately 60 inches.

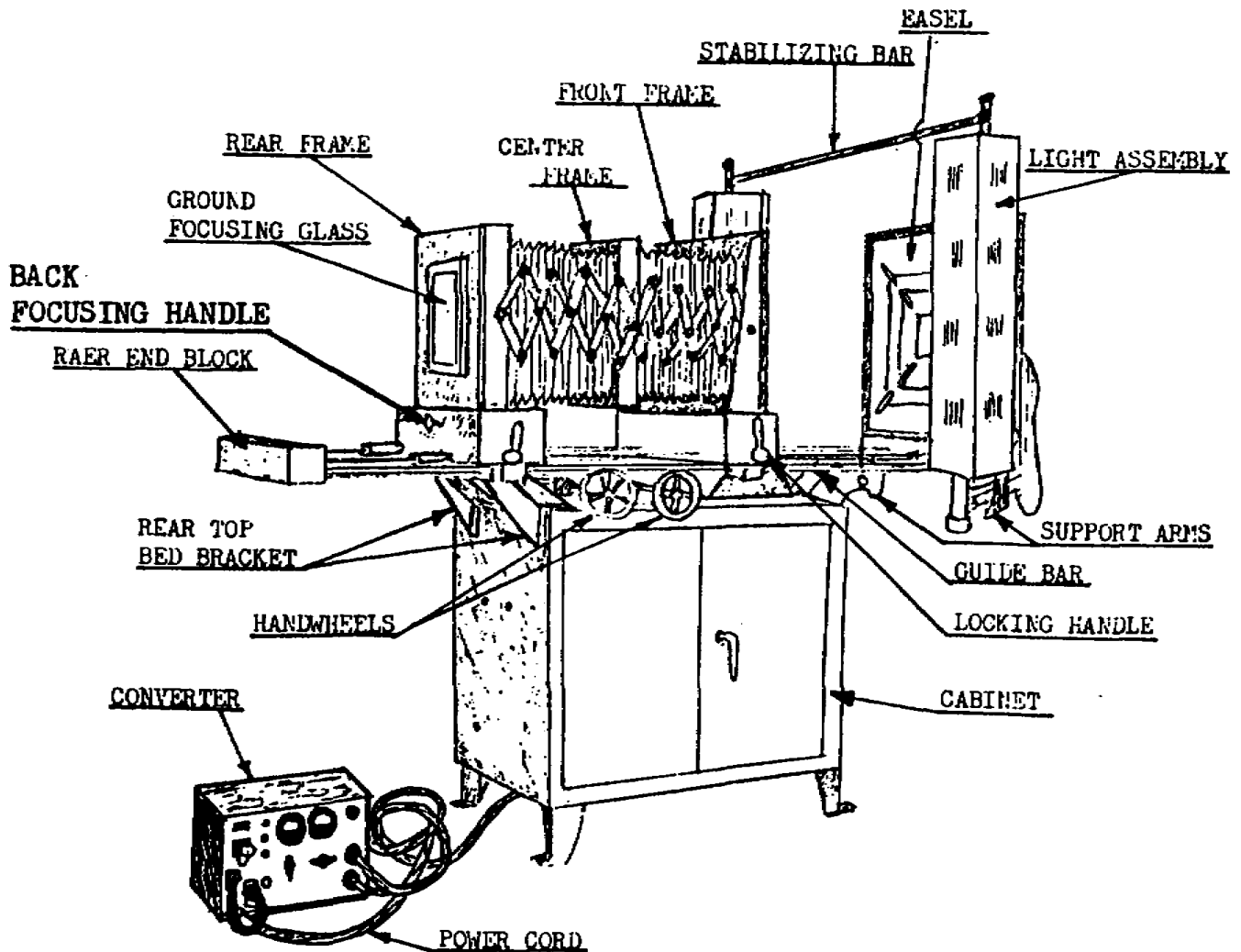

FIGURE 14. Camera set, set up for horizontal operation, right-rear view.

f. Rotate the rear handwheel (figure 14) or the camera (clockwise or counterclockwise as required) until the image on the ground focusing glass (figure 14) is coarse focused. Rotate the back focusing handle (figure 14) until the image is sharply focused.

g. If the image is not of the proper size after focusing, repeat the procedures in e and f above until a sharp image of the desired size is obtained.

h. Move all four locking handles forward to secure the carriages.

i. Gently lift the press focus lever (figure 13). The shutter will close.

EXERCISE

25. (Ref. figure 13) In order to open the lens to focus the camera, which of the following levers must be activated? (select best answer)

- a. Synchronizer Indicator Lever.
- b. Shutter Release Lever.
- c. Press Focus Lever.
- d. Aperture Lever.

26. (Ref. figure 14) After you have placed item to be copied in the easel and the lens is open to the widest f/stop, which parts of the camera must you operate in order to FOCUS the image on the ground glass? (select best answer)

- a. Rear and front frame.
- b. Handwheels and back focusing handle.
- c. Guide bars and rear end block.
- d. None of the above.

3-3 Adjusting Light Assemblies and Determining Exposure

To adjust the light assemblies, follow the procedures in a below. To determine the exposure required for the type of copy and image size used, follow the procedures in b below.

a. Adjusting light assemblies. Adjust the light assemblies as follows:

(1) Position your head in front of the lens assembly (figure 14) and study the illumination of the item to be copied.

(2) Readjust the light assemblies (para 2-5b) to produce an even illumination with no glare or hotspots.

b. Determine exposure. The exposure required for the type of copy and the image size used may be determined by the operator based upon experience. Normally, however, an exposure meter must be used. When an exposure meter is used, proceed as follows:

(1) Operate the exposure meter to measure the light from the material to be copied, and to determine the exposure setting (f/stop and time) for the light measured and for the film used.

(2) The exposure setting obtained [(1) above] is correct for objects at infinity (a lens operating at a distance from the film equal to the lens focal length). However, the lens used with the camera set operates at a distance from the film much greater (due to the bellows extension) than its 12-inch focal length. As a result, a corrected exposure setting must be determined (calculated).

(3) Calculate the corrected exposure setting as follows:

(a) Measure the bellows extension (distance from the center of the lens to the film plane).

(b) Use the following formula to calculate the corrected exposure setting:

$$CES = \frac{BE^2}{FL^2} \times EM$$

Where: CES is the corrected exposure setting in seconds.

BE is the bellows extension distance in inches [(a) above].

FL is the focal length of the lens in inches.

EM is the exposure meter setting in seconds [(1) above].

EXAMPLE: The camera set lens has a 12-inch focal length which is operating with a bellows extension of 29.5 inches. The exposure meter indicated that an exposure of 5 seconds at f.16 would be correct for the illumination and the film used. Using the formula, find the corrected exposure setting.

$$\begin{aligned} \text{CES} &= \frac{\text{BE}^2}{\text{FL}^2} \times \text{EM} \\ \text{CES} &= \frac{29.5^2}{12^2} \times 5 \\ \text{CES} &= \frac{870.25}{144} \times 5 \\ \text{CES} &= 6.04 \times 5 \\ \text{CES} &= 30.2 \text{ seconds} \end{aligned}$$

(Therefore, the corrected exposure setting is 30 seconds at f.16.)

(4) Upon completion of the corrected exposure setting calculation, set the aperture lever at the required f. stop, set the speed cam at T, and make the copy.

3-4 Making Copy

To make a copy negative, proceed as follows:

- a. Insert a loaded filmholder in the focusing back.

NOTE: The slide of the filmholder that faces the lens must have the bright side out, indicating an unexposed film.

b. Release the locking screw on the filmholder and remove the slide from the filmholder.

c. To use the cable release to produce the exposure as calculated in paragraph 3-3b, proceed as follows:

- (1) Press the cable release plunger to open the shutter.

(2) Allow the calculated amount of time to pass.

(3) Press the cable release plunger a second time to close the shutter.

d. Replace the slide in the filmholder with the black (dull) side of the slide out to indicate the film has been exposed.

e. Set the locking screw on the filmholder to hold the slide in position; remove the filmholder from the focusing back.

f. Shut down the camera set (para 3-5).

g. Process the exposed film IAW film manufacturer's instructions.

3-5 Stopping Procedures

If the camera set is to be placed in a standby condition, follow the procedures in a below. If the camera set is to be shut down overnight or for an extended period of time, follow the procedures in b below.

a. Standby shutdown.

(1) Set the MANUAL-TIMER switch (figure 7) on the converter to REMOTE TIMER OPERATION; the light assembly lamps will glow dimly.

(2) Place the lens cap on the lens.

b. Extended shutdown.

(1) Set the MAIN POWER switch (figure 7) on the converter to OFF.

(2) Place the lens cap on the lens.

EXERCISE

27. The best way to determine the illumination of the original (art work) copy, is by using the following method:
(select best answer)

- a. Pencil silhouette.
 - b. Exposure meter.
 - c. Gray card.
 - d. Eye-ball it.
-

28. After the illumination has been adjusted and is even, you must then determine the correct exposure to use (set) on the camera. This is done by using one of the following formulas: (select one).

- a. $BE^2 = \frac{EM}{FL^2} \times CES$
 - b. $EM = \frac{FL^2}{CES} \times BE^2$
 - c. $FL^2 = \frac{CES}{EM} \times BE^2$
 - d. $CES = \frac{BE^2}{FL^2} \times EM$
-

29. You have just completed setting up the original into the easel; you have checked and adjusted the camera lighting; you have measured the exposure and the bellows extension; and you now have the following information:

The camera focal length is 12 inches, with a bellows extension of 35 inches; the exposure meter read 8 seconds at f.22 for the film used. Using the following formula, compute for the CES corrected exposure setting.

$$CES = \frac{BE^2}{FL^2} \times EM$$

SECTION 4

STILL PICTURE, CAMERA SET KS-7A

OPERATOR'S MAINTENANCE

4-1 In order to maintain a high performance of a piece of equipment, whether it be a tank or a camera, it must be maintained by the operator or crew. This is called OPERATOR'S MAINTENANCE.

4-2 Scope of Operator's Maintenance

Operator's maintenance for Camera Set, Still Picture KS-7A consists of the following:

- a. Preventive maintenance.
- b. Visual inspection.
- c. Troubleshooting.

4-3 Tools and Materials Required

The following tools and materials are required for operator's maintenance:

- a. Cleaner, lens (FSN 6760-408-5175).
- b. Paper, tissue, lens (FSN 6640-393-2090).
- c. Cloth, textile, lintless (QM 27-C-11565-36).
- d. Hand blower (air syringe) (ORD 41-B-1485).
- e. Camel's Hair Brush TL-72 (FSM 7920-282-9242).
- f. Cleaning compound (FSN 7930-395-9542).

WARNING: CLEANING COMPOUND IS FLAMMABLE AND ITS FUMES ARE TOXIC. DO NOT USE NEAR A FLAME AND PROVIDE ADEQUATE VENTILATION.

4-4 Preventive Maintenance Steps

a. The daily operator's preventive maintenance steps. This is a list of steps that must be performed daily before operating the Camera Set KS-7A. The daily preventive maintenance must be done before the equipment is used each day and the appropriate entry made on DA FORM 2404, EQUIPMENT INSPECTION AND MAINTENANCE WORKSHEET, IAW TM 38-750.

b. The following preventive maintenance steps must be performed:

(1) Remove dust and lint with a soft camel's hair brush or an air syringe. If cleaning of lens assembly is required, refer to paragraph c below.

(2) Rotate the working controls on the lens assembly to be sure that they are operating properly. Excessive looseness or binding indicates a defect; when this condition is observed, turn in the lens assembly for repair or replacement using the appropriate forms as outlined in TM 38-750.

(3) Use a clean, lint-free cloth to remove dust, dirt, or moisture from external metal surfaces. If necessary, dampen the cloth with cleaning compound and then wipe with a dry clean cloth.

(4) All control knobs of the converter should work smoothly, be tight on the shafts, and should not bind. Tighten all loose knobs and be sure that the knobs do not rub against the panel.

(5) Inspect all latches for positive action. If wear or damage is apparent, refer to higher echelon for replacement using appropriate forms as outlined in TM 38-750.

c. Additional preventive maintenance information. The lens elements of the lens assembly should be cleaned once a week. DO NOT clean the lens elements more often than once a week unless necessary. Excessive cleaning can mar the lens surfaces.

(1) Raise the upper lens holder support (figure 15) and withdraw the lens assembly from the front frame.

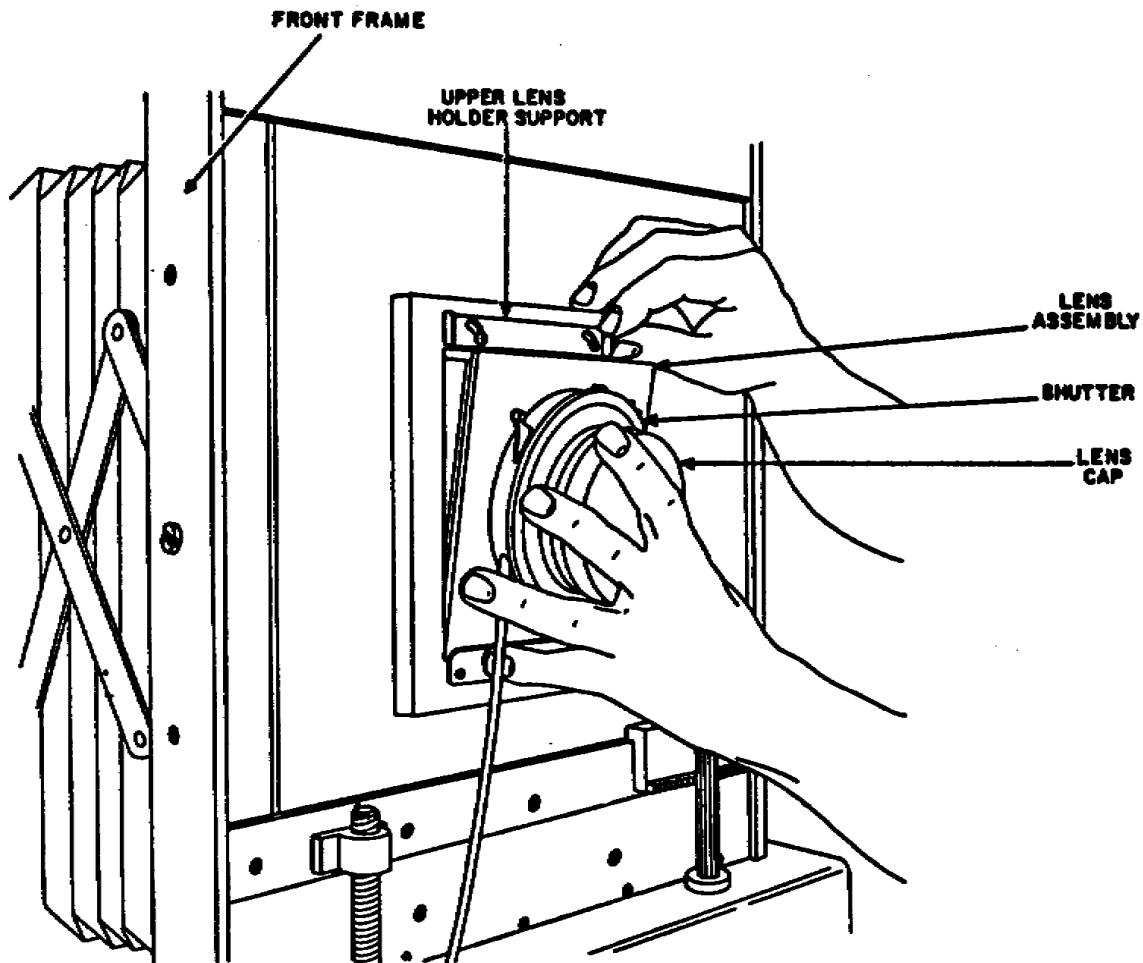

FIGURE 15. Removing and replacing lens assembly.

(2) Remove the lens cap from the front of the lens.

(3) Inspect the lens and remove all dust with the camel's hair brush.

CAUTION: DO NOT ATTEMPT TO DISASSEMBLE THE LENS ELEMENTS.

(4) If necessary, clean the lens with paper lens tissue and lens cleaner as follows:

(a) Wad a sheet of paper lens tissue and dampen it with lens cleaner.

(b) Apply the lens cleaner with a gentle circular motion.

(c) Dry the lens in the same manner with a clean sheet of paper lens tissue.

CAUTION: DO NOT USE TISSUE THAT CONTAINS SILICON. A SLIGHT DEPOSIT OF SILICON MAY BE LEFT ON THE LENS SURFACE AND AFFECT ITS PERFORMANCE.

(5) Replace the lens cap on the front of the lens.

(6) Raise the upper lens holder support and insert the lens assembly in the front frame; release the upper lens holder support.

EXERCISE

30. Which of the following tools and materials combination is NOT recommended for operator's maintenance on the KS-7A Camera Set?

- a. Hand blower, lens tissue.
- b. Cleaning compound, lens cleaner.
- c. Acedic acid, steel brush.
- d. Camel's hair brush, lintless cloth.

31. Identify the types of operator's preventive maintenance you must use for the KS-7A Camera Set.

- a. _____
- b. _____
- c. _____

4-5 Visual Inspection

When the camera set fails to perform properly, turn off the power and check all the items listed below. Do not check any item with the power on. If any of the checks (a and b below) do not locate the trouble, proceed to the equipment performance checklist (para 4-6).

- a. Check for light leakage as follows:

- (1) Remove the focusing back.
- (2) Close the shutter and darken the room.
- (3) Move a light around inside the bellows with the bellows fully extended.
- (4) Watch the outside of the bellows for pinhole or other light leakage.
- (5) Operate the handwheels to move the bellows to check for faults that may appear only while the bellows are being flexed.
- (6) Set the speed cam for various speeds and operate the shutter release lever each time. Check to be sure that the shutter closes completely at all speeds.
- (7) Replace the focusing back.

b. Check the converter as follows:

- (1) Wrong setting of switches and controls.
- (2) POWER CORD or INPUT CORD disconnected or poorly connected.
- (3) Burned out fuse (usually indicates some other fault).
- (4) Light assembly cables disconnected or poorly connected.
- (5) Burned out pilot light.

4-6 Equipment Performance Checklist

a. General. The equipment performance checklist is used to systematically check equipment performance. All corrective measures that the operator can perform are given in the corrective measures column. If the action taken by the operator does not correct the fault, additional maintenance is required by higher echelon personnel. The operator should note on the DA Form 2404 how the equipment performed and the corrective measures taken. Start at the beginning of the checklist and follow each step in sequence to locate trouble.

However, if trouble is suspected in a particular area, check at that point first and continue the steps in the order listed.

b. Checklist. Operate the equipment as shown in the checklist below.

ITEM NO.	ITEM	ACTION OR CONDITION	NORMAL INDICATION	CORRECTIVE MEASURE
1	4 by 5 filmholder (figure 8)	Load one 4 x 5 filmholder.	Filmholder properly loaded.	Check procedure for loading 4 by 5 filmholder (para 2-4).
2	8 by 10 filmholder	Load one 8 x 10 filmholder.	Filmholder properly loaded.	Check procedure for loading 8 by 10 filmholder (para 2-4).
3	MAIN POWER switch (figure 10)	Check to be sure it is set to OFF.		
4	POWER CORD	Connect to power source.		
5	KELVIN TEMPERATURE SELECTOR switch	Set to 1.		
6	INPUT VOLTAGE SELECTOR switch	Set to position that most nearly matches input voltage.		
7	Light assembly cables	Connect to converter.		
8	MANUAL-TIMER switch	Set to REMOTE TIMER OPERATION.		

P R E P A R A T O R Y

ITEM NO.	ITEM	ACTION OR CONDITION	NORMAL INDICATION	CORRECTIVE MEASURE
9	MAIN POWER switch	Set to ON.	<ul style="list-style-type: none"> a. Pilot light glows. b. All lamps in light assemblies glow dimly. c. Ammeter indicates amount of current being supplied to converter. 	<ul style="list-style-type: none"> a. Check fuse (or fuses) and replace if necessary; or, replace pilot light. b. Replace defective lamp or lamps. c. Higher echelon maintenance required.
10	MANUAL-TIMER switch	Set to MANUAL OPERATION.	All lamps in light assembly glow more brightly than noted in 9b above.	Higher echelon maintenance required.
11	KELVIN TEMPERATURE SELECTOR switch	<ul style="list-style-type: none"> a. Set to 1. b. Set to 2. 	<ul style="list-style-type: none"> a. Kelvin meter indicates 120 volts at 2900° K. b. Kelvin meter indicates 131 volts at 2992° K. 	<ul style="list-style-type: none"> a. Higher echelon maintenance required. b. Higher echelon maintenance required.

P R E P A R A T O R Y

ITEM NO.	ITEM	ACTION OR CONDITION	NORMAL INDICATION	CORRECTIVE MEASURE
P R E P A R A T O R Y				
		c. Set to 3. d. Set to 4. e. Set to 5. f. Set to 6. g. Set to 7.	c. Kelvin meter indicates 142 volts at 3082° K. d. Kelvin meter indicates 153 volts at 3176° K. e. Kelvin meter indicates 164 volts at 3268° K. f. Kelvin meter indicates 175 volts at 3360° K. g. Kelvin meter indicates 186 volts at 3450° K.	c. Higher echelon maintenance required. d. Higher echelon maintenance required. e. Higher echelon maintenance required. f. Higher echelon maintenance required. g. Higher echelon maintenance required.
12	KELVIN TEMPERATURE SELECTOR switch	Adjust to position at which Kelvin meter indicates desired color temperature.		
O P E R A T I O N				

ITEM NO.	ITEM	ACTION OR CONDITION	NORMAL INDICATION	CORRECTIVE MEASURE
13	Easel (figure 11)	Load easel with test object of standard size rigid copy. <u>NOTE:</u> Use any available standard size rigid copy.	Easel properly loaded.	Check easel loading procedures for standard size rigid copy (para 2-6).
14	4 by 5 focusing back (figure 3)	Install 4 by 5 focusing back in rear frame (figure 3).	4 by 5 focusing back held in place in rear frame.	Higher echelon maintenance required.
15	Size and focusing	Adjust size and focusing (para 3-2).	Image on ground focusing glass is sharp and of desired size.	Check to be sure lens cap is removed from lens (figure 13). Check aperture lever setting (para 3-2). Check press focus lever position (para 3-2). Check operation of locking handles and handwheels (para 2-1).

OPERATION

OPERATION

O P E R A T I O N

ITEM NO.	ITEM	ACTION OR CONDITION	NORMAL INDICATION	CORRECTIVE MEASURE
16	Light assemblies	Adjust light assemblies for even light and for no glares or hotspots on easel (para 3-3).	Even light distribution on easel.	Readjust light assemblies (para 3-3).
17	Exposure determination	Determine exposure required for object and amount of light (para 3-3).	Correct exposure determined.	Check exposure meter operating procedure. Check measurement of bellows extension. Check calculation procedure (para 3-3). Check setting of aperture lever and speed cam (para 3-3).
18	Copying	Insert 4 by 5 film-holder in 4 by 5 focusing back (figure 3) and make two copies of test object (para 3-4).	Adequate negatives produced.	Refer to paragraph 4-7.

ITEM NO.	ITEM	ACTION OR CONDITION	NORMAL INDICATION	CORRECTIVE MEASURE
19	Easel (figure 11)	Remove standard size rigid copy from easel; load easel with test transparency.	Easel properly loaded.	Check easel loading procedures for transparencies (para 2-6).
20	8 x 10 focusing back (figure 4)	Remove 4 by 5 focusing back from rear frame and replace with 8 x 10 focusing back.	8 x 10 focusing back held in place in rear frame.	Higher echelon maintenance required.
21	Size and focusing	Refer to item 15 above.		
22	Light assemblies	Refer to item 16 above.		
23	Exposure determination	Refer to item 17 above.		
24	Copying	Insert 8 x 10 film-holder in focusing back (figure 3) and make two copies of test object (para 3-4).	Adequate negative produced.	Refer to paragraph 4-7.

O P E R A T I O N

ITEM NO.	ITEM	ACTION OR CONDITION	NORMAL INDICATION	CORRECTIVE MEASURE
STOPPING	25 MAIN POWER switch (figure 7)	Set to OFF.	Pilot light and lamps in light as- semblies go out.	Higher echelon mainte- nance required.
	26 Lens cap (figure 15)	Replace on lens.		

EXERCISE

32. In order to perform a visual inspection of the bellows correctly, you must do it the following way: _____

(write statement)

4-7 Operator's Troubleshooting Checklist

a. General. This checklist helps the operator sectionalize and/or correct certain troubles. The troubles and correction measures listed are those the operator can accomplish. If the corrective measures suggested do not restore normal equipment performance, troubleshooting is required by higher echelon maintenance personnel. Note on the DA Form 2404 what corrective measures were taken and how the equipment performed at the time of failure.

b. Procedure. Generally, the operator can troubleshoot the camera set by examining the processed negatives for obvious symptoms. The symptoms apply to negatives developed for the normal time in standard developing solutions. Refer to the symptom column to locate the difficulty indicated on the negative.

Item No.	Symptom	Probable trouble	Corrective measure
1	Negative image too light	Underexposure Error in developing procedure.	Make new negative with more exposure. Check developing procedure (TM 11-401) and make new negative.
2	Negative image too dark	Overexposure	Make new negative with less exposure.

Item No.	Symptom	Probable trouble	Corrective measure
2 (cont)		Error in developing procedure.	Check developing procedure (TM 11-401) and make new negative.
3	No image on negative	<p>Lens cap not removed from lens (fig. 15).</p> <p>Filmholder slide not removed from filmholder during copying procedure.</p> <p>Error in developing procedure.</p>	<p>Remove lens cap from lens and make new negative.</p> <p>Make new negative; be sure to remove filmholder slide.</p> <p>Check developing procedure (TM 11-401) and make new negative.</p>
4	Overall fog on negative; film margins fogged	<p>Excessive light in darkroom.</p> <p>Film past expiration date.</p> <p>Error in developing procedure.</p>	<p>Reduce darkroom light level and make new negative.</p> <p>Use fresh film and make new negative.</p> <p>Check developing procedure (TM 11-401) and make new negative.</p>
5	Uneven fog on negative; film margins not fogged	Internal reflection in camera or pinholes in bellows.	Remove focusing back from rear frame and inspect interior of camera for shiny areas or pinholes; cover shiny areas or pinholes with dull black tape.
6	Negative image uneven	Uneven illumination during copying procedure.	Readjust color temperature output of converter (para 2-5) and reposition light assemblies (para 2-5).

Item No.	Symptom	Probable trouble	Corrective measure
7	Hotspots on negative	Light reflections on easel glass photographed.	Position light assemblies so that no reflections show in picture area when viewed from a point directly in front of lens.

EXERCISE

33. You have just exposed and processed a sheet of 4" x 5" black and white film and you see that the image on the film is too light. This is due to _____. What is the corrective measure you must take in order to correct this?

ANS: _____

34. Light reflections on the easel glass will show in the negative in the form of what? _____. In order to correct for this symptom, you must do the following:

 (complete statement)

You should now have a general knowledge on the operation and operator's maintenance of the Camera Set, Still Picture KS-7A. This lesson will help you to better perform your assigned tasks and give you the satisfaction of a job well done.

SECTION 5

STILL PICTURE, CAMERA SET KS-17A

5-1 Scope

a. This section describes Camera Set, Still Picture KS-17A (figure 1) and covers its installation, operation, and operator's maintenance.

b. Camera Set, Still Picture KS-17A is a self-contained portable view camera. The KS-17A is used to make still photographs using 4" x 5" cut film or film pack.

c. The KS-17A is intended for use under field conditions.

d. Reference to the Camera Set, Still Picture KS-17A will, for the rest of this lesson, be "the KS-17A".

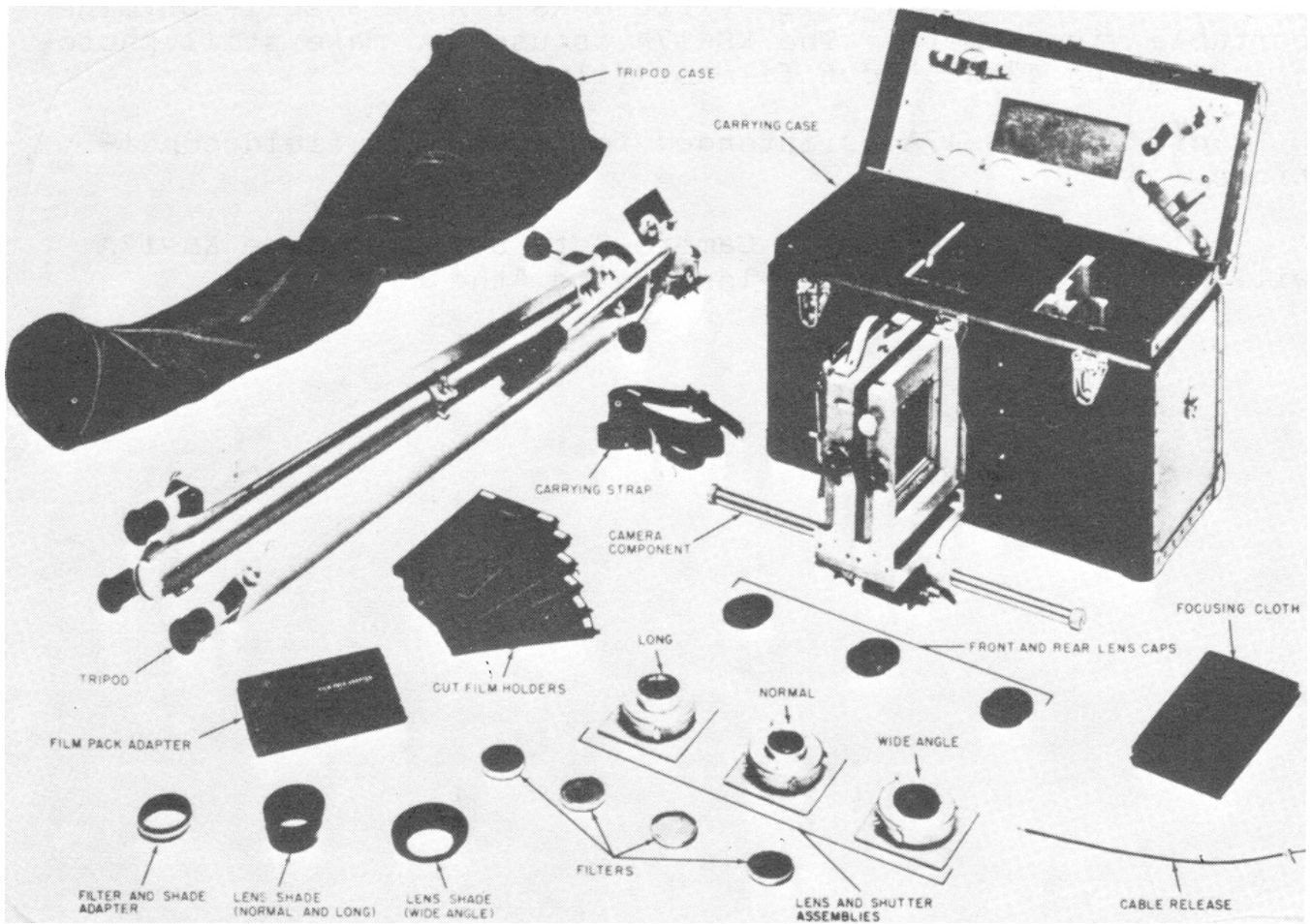

FIGURE 1. Camera Set, Still Picture KS-17A, components.

5-2 Technical Characteristics

Camera:

Type.....View, still picture, rotating back.
Format.....4 by 5 inch.
Film accommodation.....Cut film or film pack.
Lenses.....Wide angle, normal, and long (mounted
on individual lens boards with
between-the-lens shutters).

Camera component:

Bed.....Monorail.
Front adjustments.....Tilt, swing, slide, and elevation.
Tilt.....26° maximum from plan perpendicular to
monorail bed.
Swing.....12° maximum in either direction from
plane perpendicular to monorail bed.
Slide.....7/8 inch maximum left or right from
centerline of monorail bed.
Elevation.....3 inch maximum rise, 1 inch maximum
drop from normal (centered) position.
Back adjustments.....Tilt, swing, slide, and rotation.
Tilt.....26° maximum from plane perpendicular
to monorail bed.
Swing.....12° maximum in either direction from
plane perpendicular to monorail bed.

Slide.....7/8 inch maximum left or right from
centerline of monorail bed.

Rotation.....360° in either direction.

Bellows draw.....15 inches.

Lens and shutter assemblies:

Lenses:

Wide angle:

Type.....Anastigmatic, f/8 coated glass-air
surfaces.

Cable release.....10 inches long with locking device.

Focusing cloth.....48 by 70 inches.

Cut filmholders:

Type.....Double-sided, equipped with slide
locks.

Film accommodated.....Cut film, 4 by 5 inch, two sheets.

Film pack adapter.....Accommodates one 4 by 5 inch film
pack.

Tripod:

Type.....Floating action with panhead.

Closed length.....44 inches.

Leg extension.....24-1/2 inches maximum.

Maximum height of panhead.....90 inches.

Rotation of panhead.....360°.

Mounting.....Between-the-lens shutter.

Focal length.....111 millimeters.

Angle of field.....39° maximum.

Normal:

Type.....Anastigmatic, f/4.5, coated glass-air surfaces.

Mounting.....Between-the-lens shutter.

Focal length.....165 millimeters.

Angle of field.....25° maximum.

Long:

Type.....Anastigmatic, f/6.3, coated glass-air surfaces.

Mounting.....Between-the-lens shutter.

Focal length.....216 millimeters.

Angle of field.....21-1/2° maximum.

Shutters (common to all lens and shutter assemblies):

Type.....Between-the-lens.

Size.....No. 3.

Speeds.....1/200, 1/100, 1/50, 1/25, 1/10, 1/5, 1/2, and 1 second, bulb, and time.

Diaphragm stops:

Wide angle lens.....f/8, f/11, f/16, f/22, f/32, and f/45.

Normal lens.....f/4.5, f/5.6, f/6.4, f/8, f/11, f/16, f/22, and f/32.

Long lens.....F/6.3, f/8, f/11, f/16, f/22, f/32, and f/45.

Synchronism.....Built-in electrical contacts, continuously adjustable from 0 to 20 milliseconds with designated color dot settings, separate cocking.

Designated settings:

Red dot.....20 milliseconds delay.
Blue dot.....5 milliseconds delay.
White dot.....0 millisecond delay.

Lens caps.....Velvet lined, friction fit.

Filters:

Type.....Type II gelatine.
Quantity.....4 (K2, G, and A, and pola screen).
Mounting.....B-glass.
Size.....Series VII.

Lens shades:

Quantity.....2 (wide angle lens and normal and long lens).
Mounting.....Screw in.
Size.....Series VII.

Filter and shade adapter:

Accommodation.....Filter and/or lens shade.
Mounting.....Friction fit over front lens barrel.
Tilt of panhead.....150°.

Temperature and environ-
mental ranges:

Temperature:

Operation.....-35° F to +120° F.

Storage temperature.....-65° F to +160° F.

Relative humidity.....Up to 90 percent.

Elevation.....Up to 10,000 feet above sea level.

5-3 Camera Set Description

a. The KS-17A (figure 1) includes two major components (camera component and tripod) and various minor components. The minor components consist of three lens and shutter assemblies (mounted on individual lens boards), a cable release, three sets of front and rear lens caps, two lens shades, four filters (red, yellow, deep yellow, and pola screen), a filter and shade adapter, a focusing cloth, tripod case, six cut film holders and a film pack adapter, a carrying strap and a carrying case.

b. The camera component and the minor components are stored in the carrying case (figure 3). The tripod (with the attached panhead) (figure 7) is stored in the tripod case.

5-4 Description of Camera Set Components

a. Camera component. The camera component, with a lens and shutter assembly attached, is a monorail bed view camera (figure 2). Focusing is accomplished by means of front and rear carriage adjust knobs (figure 4). An adjustable mounting adapter permits positioning the monorail bed so that the camera's center of gravity is over the point of attachment to the panhead (figure 2). The camera has provisions that permit vertical tilt, horizontal swing, and lateral and vertical movement of the optical axis and film plane with respect to each other. Click stops facilitate retiming movable parts to their normal resting position. A rack and pinion gear arrangement allows the lens and shutter assembly to be raised or lowered with respect to the camera's film plane. A camera level vial (figure 4) is provided on the

top of the rear frame to facilitate the leveling of the camera when it is set up for operation. A lift handle (figure 5) attached to the revolving back permits the cut film holder and film pack adapter to be inserted in the camera easily. A 360° revolving back arrangement permits composing and making vertical or horizontal photographs without disturbing the camera's position on the tripod.

b. Tripod. The tripod (figure 2) is equipped with a detachable panhead and a springloaded central support column (center post). The center post can be raised or lowered in a center post tube to which the three telescoping legs are attached. Each leg telescopes in two sections and is equipped with a rubber foot. A spirit level vial (figure 5) is provided on the panhead to facilitate leveling the equipment when it is set up for operation.

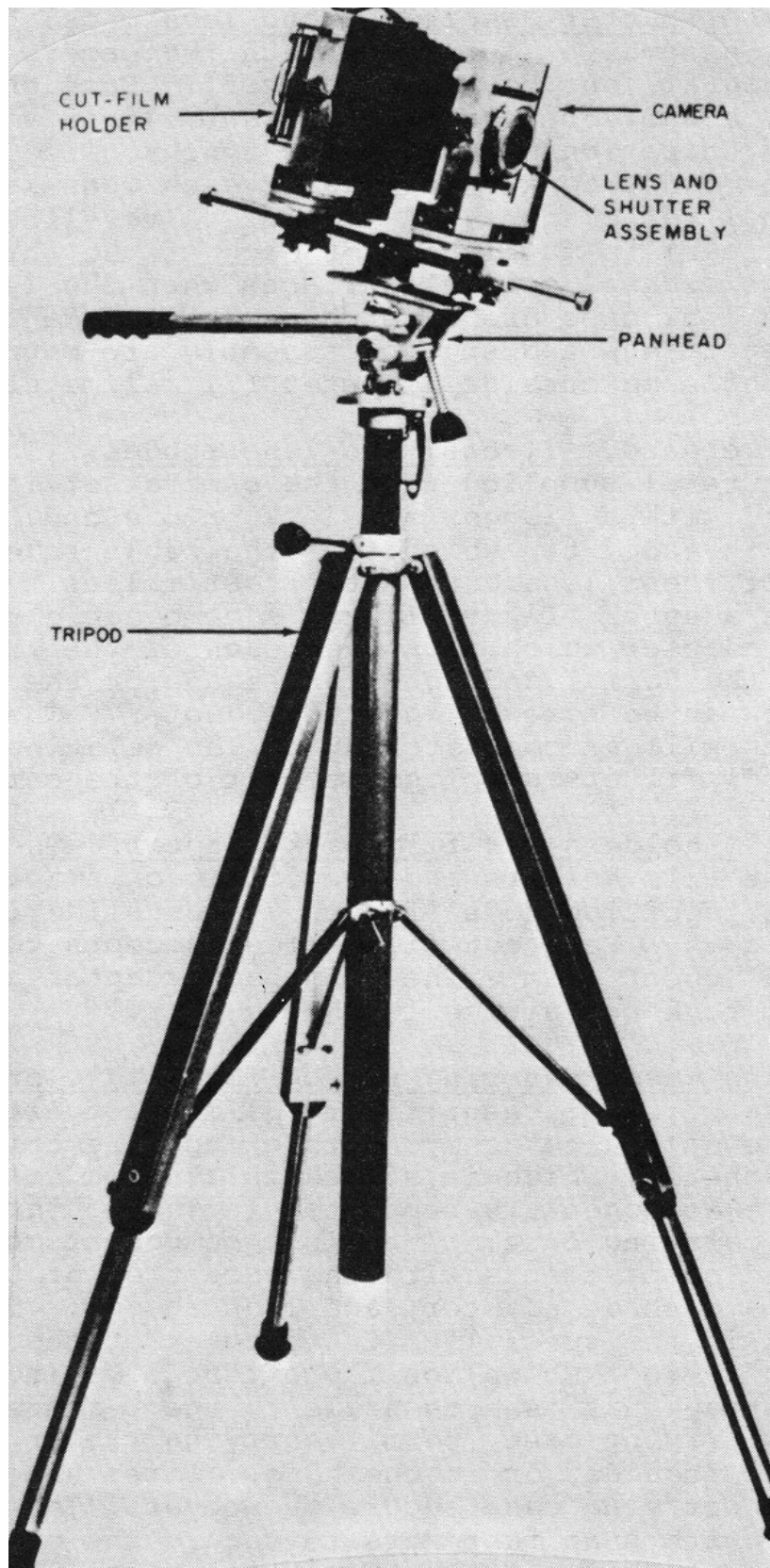

FIGURE 2. Camera mounted on tripod.

c. Lens and shutter assemblies and lens caps. The lens and shutter assemblies furnished with the camera set are mounted on individual lens boards (figure 7). Each shutter is fitted to accept a cable release and has a built-in adjustable time delay synchronization mechanism for synchronized flash photography. The glass-to-air surface of each lens is coated to reduce internal reflections. A pair of velvet-lined lens caps (front and rear) is furnished for each of the three lenses to protect the exposed optical surfaces when the lens is not in use. The lens caps are interchangeable since the optical parts of each lens and shutter assembly are mounted in barrels having the same outside diameter (51 millimeter).

d. Cable release, filters, and lens shades. The cable release (figure 7) supplied with the camera set is flexible and equipped with a plunger and lock on one end. The other end has a threaded tip which fits the cable release socket on each of these lens and shutter assemblies. The filter and shade adapter (figure 1) has a removable retaining ring and an adapter which fits over each of the three lenses. Either the normal and long lens shade or the wide angle lens shade can be screwed into the adapter. The filter and shade adapter will accommodate any of the gelatine (optical glass mounted) filters supplied as part of the camera set.

e. Cut film holders and film pack adapter. The dark slides of the cut film holders and the film pack adapter have raised identification dots (figure 8) for slide identification in the dark. Each cut film holder accepts two sheets of 4" x 5" sheet film. The film pack adapter accepts one 4" x 5" film pack containing 16 sheets of film.

f. Carrying case, carrying strap, focusing cloth, and tripod case. The carrying case (figure 3) has compartments to accept all the camera set components except the tripod (and attached panhead), which is stored in its own tripod case. The camera component is supported in the center compartment of the carrying case. The minor components are stored in the end compartments with the exception of the filters, filter and shade adapter, and lens shades. These items are stored in the specially fitted cover of the carrying case. A handle (not shown) on top of the carrying case and a carrying strap that is attachable to the D-rings on the ends of the carrying case, permit carrying the enclosed equipment off the shoulder or in the hand. Three hinged fasteners on the carrying case secure the cover. The tripod case is equipped with snap fasteners to secure the opening end. A handle on the side of the tripod case facilitates transporting the tripod.

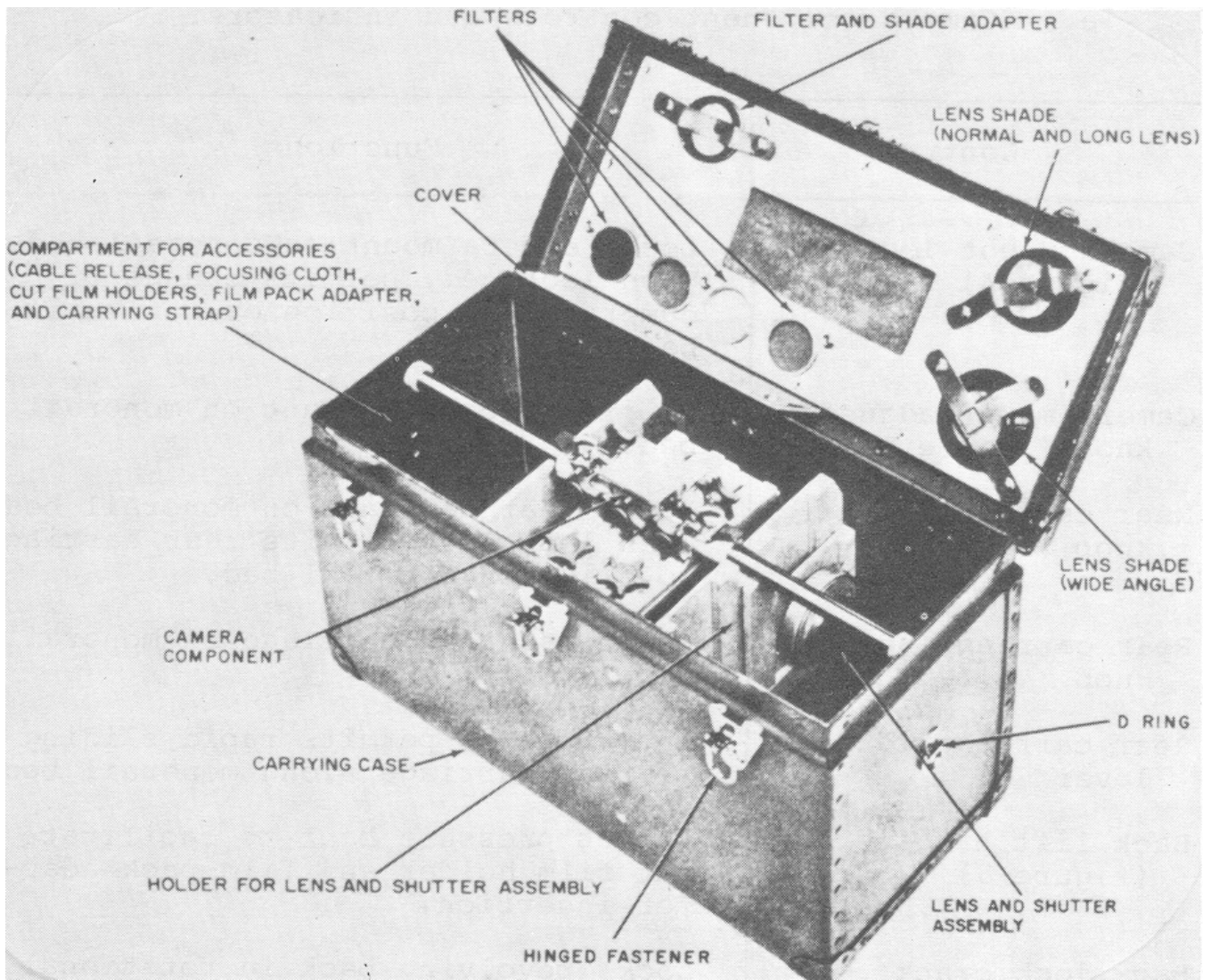

FIGURE 3. Carrying case, interior view.

5-5 Controls and Indicators.

In order to properly operate the KS-17A, you must understand the function and purpose of the various camera controls and indicators.

a. Camera component controls and indicators.

Control	Function
Camera mount lock (figure 4)	Locks camera mount on monorail bed. When loosened, permits change of camera mount position on monorail bed.
Camera mount adjust knob (figure 5)	Positions camera mount on monorail bed.
Rear carriage lock knob (figure 4)	Locks rear carriage on monorail bed. When loosened, permits rear carriage to slide on monorail bed.
Rear carriage adjust knob	Positions rear carriage on monorail bed.
Rear carriage release lever	When raised, permits rapid sliding of rear carriage along monorail bed.
Back lift handle (figure 5)	Raises pressure back to facilitate cut film holder and film pack adapter insertion.
Back lock crank	Locks revolving back in rotational position selected. When loosened, permits rotation of revolving back.
Rear slide and swing lock knob	Locks rear frame (figure 4) on rear carriage. When loosened, permits swinging and/or sliding of rear frame on rear carriage.
Rear pivot lock knob (figure 4)	Locks rear frame at degree of vertical tilt selected. When loosened, permits change in degree of vertical tilt.
Front carriage lock knob	Locks front carriage on monorail bed. When loosened, permits front carriage to slide on monorail bed.

Control	Function
Front carriage adjust knob	Adjusts position of front carriage on monorail bed.
Front carriage release lever	When raised, permits rapid sliding of front carriage on monorail bed.
Front slide and swing lock knob (figure 5)	Locks front frame in position on front carriage. When loosened, permits swinging and/or sliding of front frame on front carriage.
Front pivot lock knob (figure 4)	Locks front frame in degree of vertical tilt selected. When loosened, permits change in degree of tilt.
Camera level vial	Facilitates leveling camera component.
Pinion knob (figure 7)	Raises and lowers lens board mounting plate.
Lens board retainer	Secures lens board to lens board mounting plate.

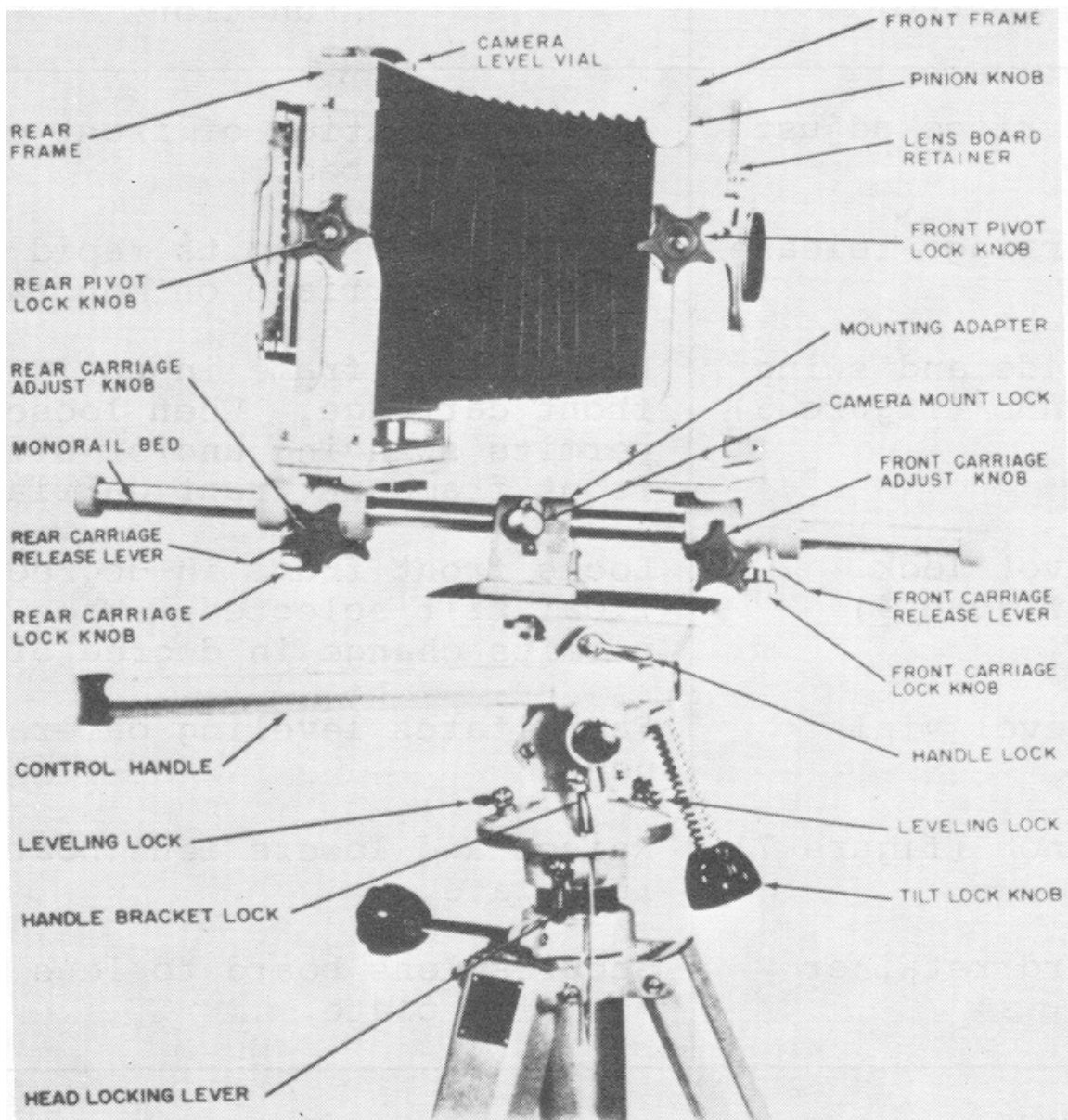

FIGURE 4. Camera component and tripod, right side view, operating controls.

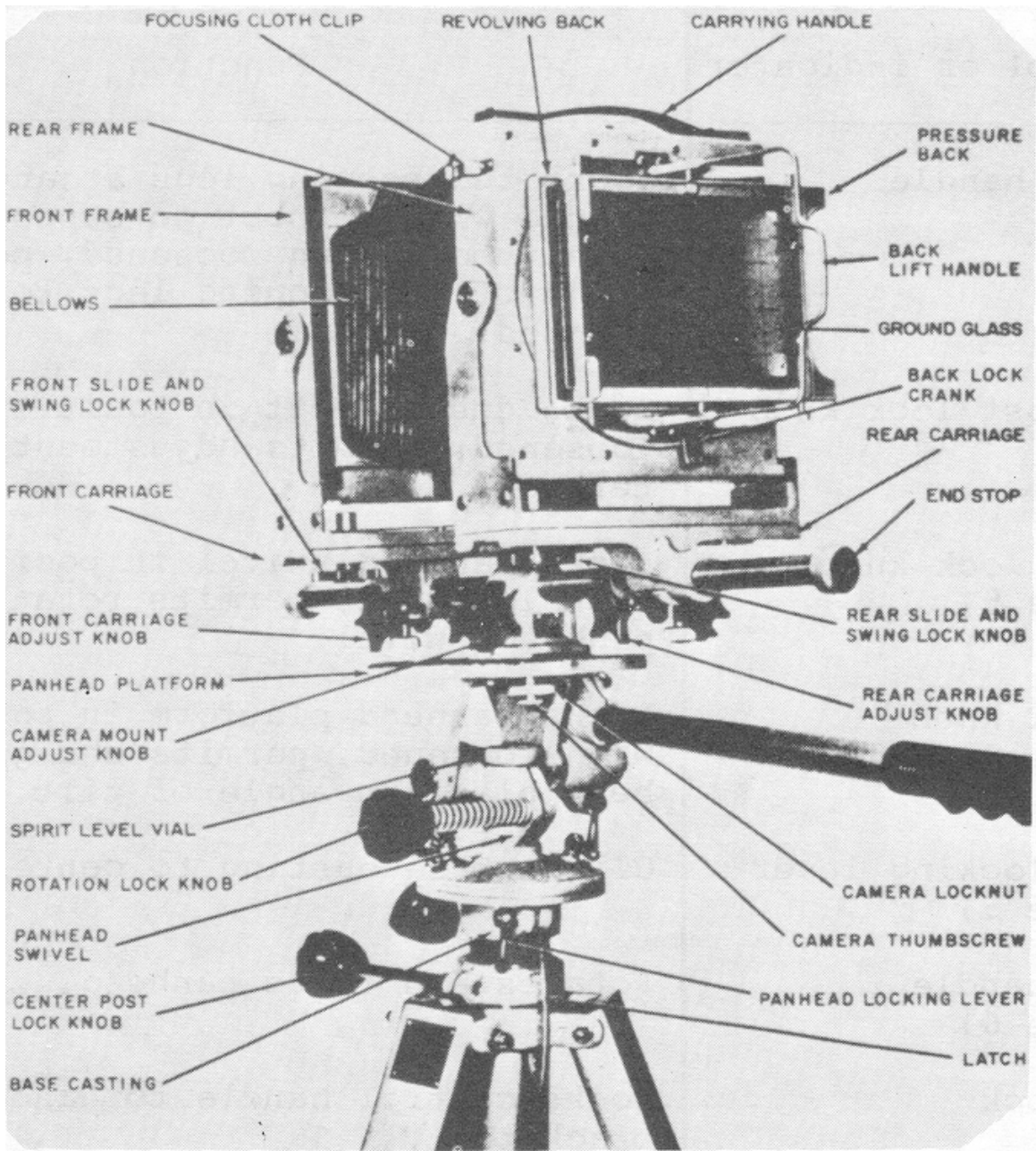

FIGURE 5. Camera component, left rear view, operating controls.

b. Tripod controls and indicators.

Control or indicator	Function
Leg thumbscrews (figure 6)	Locks telescoping legs in position. When loosened, permits telescoping legs to be lengthened or shortened.

Control or indicator	Function
Leg lock handle	Locks telescoping legs at angle selected with respect to support column tube. When loosened, permits angle of telescoping legs to be changed.
Center post lock knob	Locks center post in position. When loosened, permits adjustment of center post height.
Rotation lock knob (figure 5)	Locks panhead swivel in position. When loosened, permits rotation of panhead swivel.
Tilt lock knob (figure 6)	Locks panhead platform in position. When loosened, permits changing panhead platform angle of tilt.
Panhead locking lever (figure 5)	Clamps base casting to center post.
Control handle (figure 6)	Rotates and tilts panhead.
Handle lock	Locks control handle to handle bracket.
Handle bracket lock	Locks handle bracket on cross shaft.
Latch (figure 5)	Secures center post in telescoped position.
Leveling locks (figure 6)	Secure head casting to base casting.
Panhead level vial (figure 5)	Facilitates leveling tripod.
Camera thumbscrew	Secures camera to panhead.
Camera locknut	Secures camera thumbscrew to panhead platform.

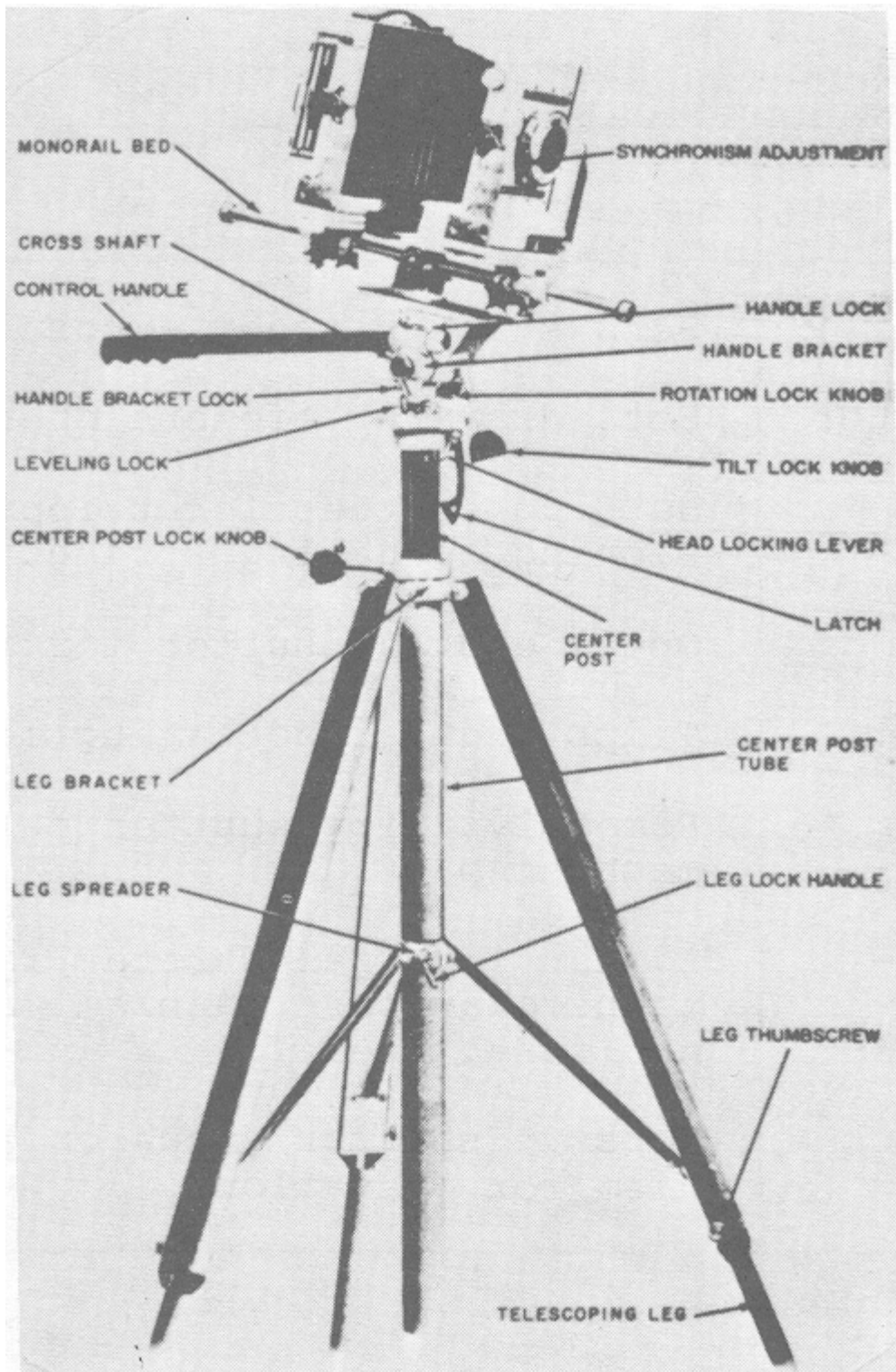

FIGURE 6. Tripod, operating controls.

c. Lens and shutter assembly controls and indicators.

(1) Controls.

Control	Function
Speed selector ring	Sets shutter speed exposure timing.
Lens opening selector	Sets diameter of lens opening (f/stop).
Cocking lever	Sets up shutter for tripping by tensioning actuating spring.
Focus button	Opens cocked shutter for focusing.
Release lever	Trips shutter actuating mechanism.
Cable release	Remotely trips shutter actuating mechanism.
Synchronism adjustment wheel	Adjust internal shutter synchronization delay for flashlamp and electronic flash use.
Synchronization cocking lever	Sets up shutter synchronizing mechanism for operation.

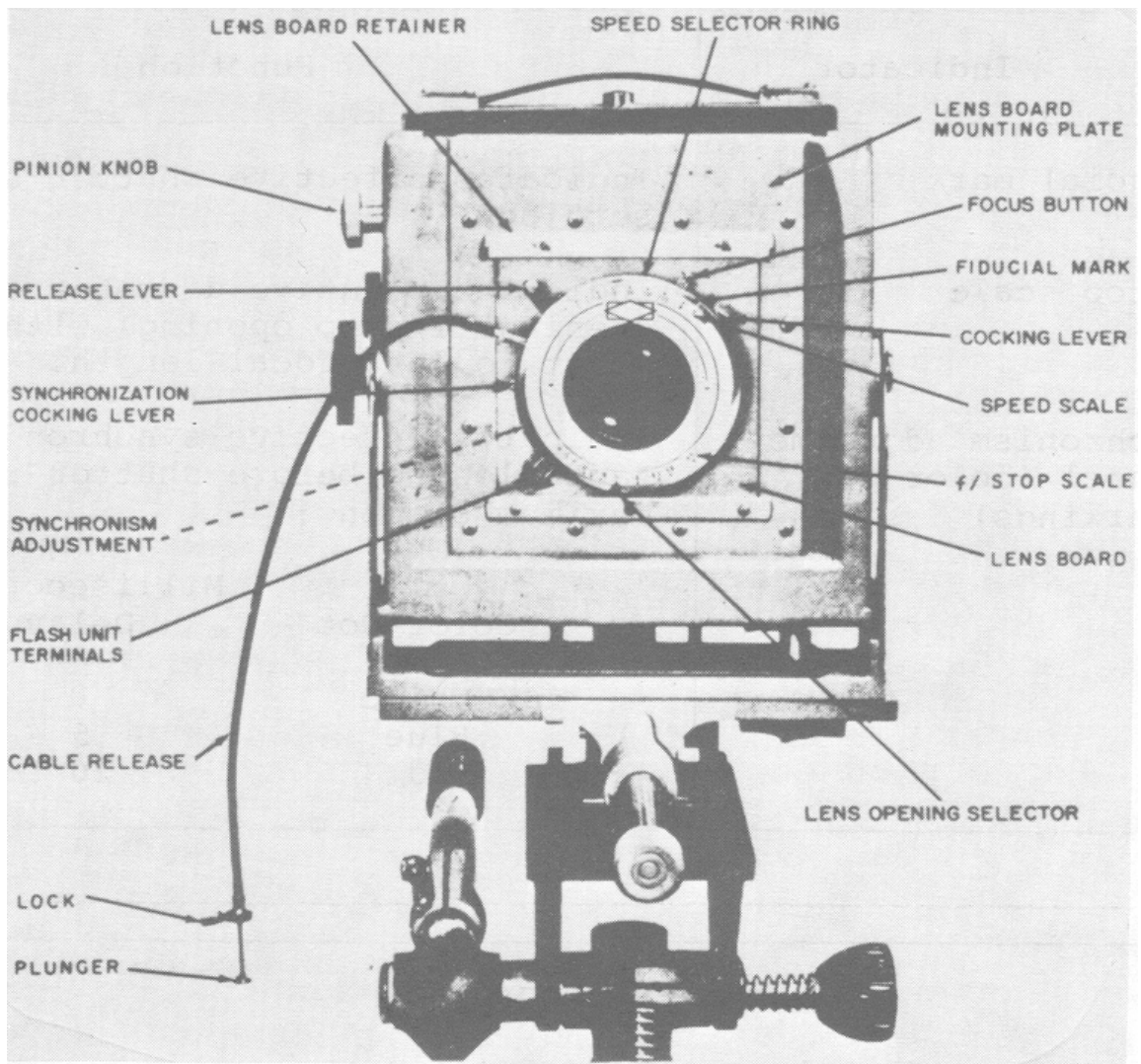

FIGURE 7. Controls on lens and shutter assembly.

(2) Indicators.

Indicator	Function
Speed scale	Indicates length of time (in seconds) shutter will remain open during an exposure.

Indicator	Function								
Fiducial mark	Indicates effective shutter speed setting.								
f/stop scale	Indicates relative diameter of lens opening (f/stop opening) with respect to lens focal length.								
Synchronism adjustment wheel (color dot markings)	<p>Indicates effective synchronism contact closing before shutter reaches maximum opening:</p> <table data-bbox="771 577 1356 787"> <thead> <tr> <th data-bbox="771 577 1112 640">Color Dot</th> <th data-bbox="1112 577 1356 640">Milliseconds Delay</th> </tr> </thead> <tbody> <tr> <td data-bbox="771 672 1112 703">White</td> <td data-bbox="1112 672 1356 703">0</td> </tr> <tr> <td data-bbox="771 703 1112 735">Blue</td> <td data-bbox="1112 703 1356 735">5</td> </tr> <tr> <td data-bbox="771 735 1112 766">Red</td> <td data-bbox="1112 735 1356 766">20</td> </tr> </tbody> </table>	Color Dot	Milliseconds Delay	White	0	Blue	5	Red	20
Color Dot	Milliseconds Delay								
White	0								
Blue	5								
Red	20								

EXERCISE

35. You want to change the focal length of the camera (distance between lens and ground glass). Which of the following controls should you use to do this? (Ref. figure 4)

- a. Rear pivot lock knob and control handle.
- b. Rear frame and front pivot lock knob.
- c. Handle lock and tilt lock knob.
- d. Front carriage adjust knob and rear carriage adjust knob.

36. What is the purpose of the camera level vial?

ANS: _____

37. The following function is done by what control? "Locks panhead platform in position. When loosened, permits changing panhead platform angle of tilt."

ANS: _____

38. You are getting ready to focus your camera, prior to making an exposure, for which you must operate which of the following controls? (circle one)

- a. Speed selector ring.
 - b. Lens opening selector.
 - c. Focus button.
 - d. Synchronization cocking lever.
- _____

39. In order to do the following function, "Indicates length of time (in seconds) shutter will remain open during an exposure," you must operate which indicator?

ANS: _____

5-6 Preliminary Procedures

General. The 4" x 5" film or film pack used will depend on the individual situation and mission to be accomplished. Instructions for loading the cut film holders and the film pack adapter are outlined in a and b below. Refer to TM 11-401-1 and the film manufacturer's instruction sheet (packed with the film to be used) for additional information, such as exposure combination (f/stop and time), types of developer, development time, etc.

a. Loading cut film holders (A, figure 8). Load the cut film holders only in a darkroom. Panchromatic film must be handled in total darkness: Other films may be handled in a darkroom equipped with recommended safelight.

(1) Withdraw the dark slide from the cut film holder.

(2) Swing the bottom flap out to open the bottom of the cut film holder.

(3) Grasp a sheet of cut film by the edges so that the emulsion (dull) side is up and the identification notches are in the upper right-hand corner as shown.

NOTE: The identification notches may be felt with the right index finger when the unnotched shorter edge is toward the operator.

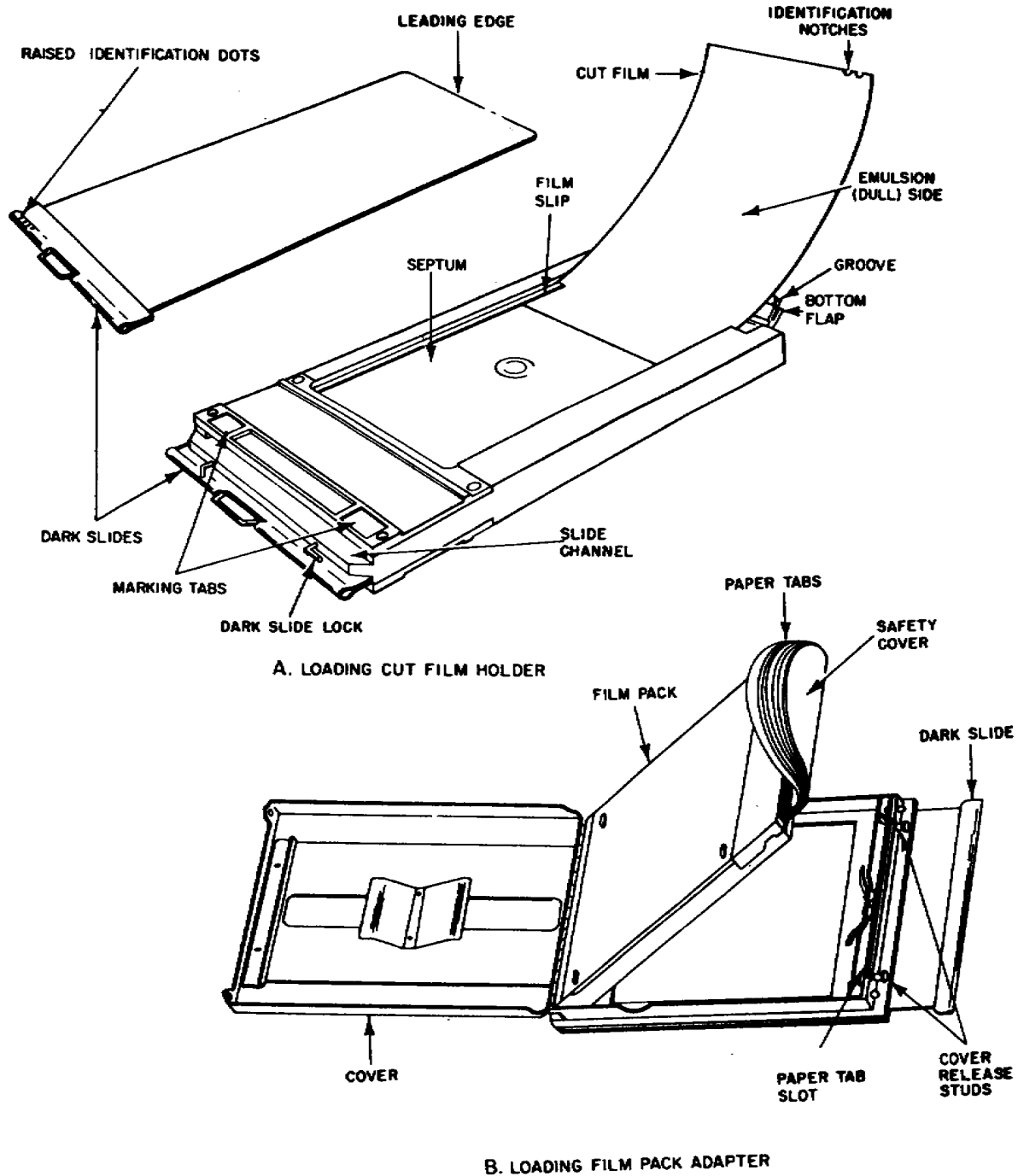

FIGURE 8. Loading cut film holder and film pack adapter.

(4) Slip the corners of the unnotched shorter edge of the cut film under the film slips (along each long side of the septum) and slide the cut film completely into the cut film holder.

(5) Swing the bottom flap closed and hold down firmly.

(6) Insert the dark slide into the slide with the channel so that the raised identification dots face away from the cut film holder.

(7) Push the dark slide all the way into the cut film holder; make sure the end of the leading edge of the dark slide engages the groove along the edge of the bottom flap.

(8) Turn the slide hook over the end of the dark slide to prevent accidental removal of the dark slide.

(9) Load the reverse side of the cut film holder by repeating the procedures in (1) through (8) above.

(10) Load additional cut film holders by repeating the procedures in (1) through (9) above.

b. Loading film pack adapter (B, figure 8). The film pack adapter may be loaded under existing lighting conditions. Do not expose the film pack to direct sunlight during loading.

(1) Make sure the dark slide is inserted in the film pack adapter.

(2) Simultaneously press the two cover release studs to open the cover.

(3) Unwrap the film pack and insert in the film pack adapter as shown.

CAUTION: Hold the film pack carefully by the sides. DO NOT depress the black safety cover or twist the metal frame; to do so may cause light to enter the film pack.

(4) Make sure that the film pack is inserted in the film pack adapter with the paper safety cover facing the dark slide (down), and that all the paper tabs rest in the paper tab slot.

(5) Close the cover; make sure it latches and that all the paper tabs are centered in the paper tab slot.

(6) Draw out the safety cover to its stop (about 5 inches) and tear it off.

EXERCISE

40. How can you make sure that the 4" x 5" cut film you are loading will be loaded correctly in the cut film holder(s)?

ANS: _____

41. When loading a film pack adapter with a film pack, the safety paper must be facing which way in the film pack adapter?

ANS: _____

5-7 Setting Up Tripod. Remove the tripod from the tripod case and set it up as follows:

a. Loosen the three leg thumbscrews (figure 6) and extend the three telescoping leg extensions. Perform this operation with the telescoping legs closed against the center post tube so that all three legs can be extended approximately the same amount.

b. Tighten the leg thumbscrews to secure the telescoping legs in their extended position.

c. Loosen the leg lock handle and spread the telescoping legs away from the center post tube to provide a firm stance. Tighten the leg lock handle securely.

d. Loosen the tilt lock knob and place the top surface of the panhead in an approximately horizontal position.

NOTE: The position of the control handle with respect to the plane of the panhead platform (figure 5) can be changed by loosening the handle bracket lock and shifting the handle bracket on the cross shaft. Tighten the handle bracket lock securely after making the desired adjustment. The protrusion of the control handle (figure 6) may be shortened by loosening the handle lock and sliding the shaft of the control handle in the handle bracket. Tighten the handle lock securely after adjusting the control handle.

e. Loosen both the leveling lock and shift the position of the upper portion of the base casting until the spirit level vial (figure 5) indicates a level condition. Only limited adjustment is available by this method. If leveling cannot be obtained, lengthen or shorten one of the telescoping legs to bring the panhead within range of the base casting adjustment. Tighten leveling locks securely after making the final adjustment.

EXERCISE

42. In order to insure that the tripod stands approximately perfectly level, you should use the _____ in order to achieve this.

5-8 Camera Component

a. Carefully remove the camera component from the carrying case.

b. Center bottom of the mounting adapter (figure 5) over the camera thumbscrew projecting through the panhead platform.

c. Turn the camera thumbscrew into the camera mounting adapter and tighten the camera locknut securely.

5-9 Selecting and Attaching Lens and Shutter Assembly

a. Selecting lens and shutter assembly. The nature of the photographic mission to be accomplished will determine the selection of the lens. Refer to TM 11-401-1 for lens selection information.

(1) Remove the front and rear lens caps from the lens and shutter assembly selected.

(2) Check the optical parts for cleanliness; if cleaning is required, refer to paragraph 6-6 for cleaning information.

(3) Install the front lens cap on the front cell of the lens and shutter assembly.

(4) Return rear lens cap to carrying case for safe storage.

b. Installation of lens and shutter assembly. Install the lens and shutter assembly in the front of the camera component as follows:

(1) Slide the lens board retainer (figure 7) to the left and upward as far as possible.

(2) Place the lens board in position on the lens board mounting plate with the lower edge behind the fixed lower lens board retainer.

(3) Set the lens board completely in the recess of the front of the lens board mounting plate.

(4) Slide the lens board retainer down and to the right as far as possible to secure the lens board in place.

NOTE: Leave the front lens cap in position until actual use of the camera is required. This protects the lens from damage and unnecessary accumulation of dust and foreign matter.

(5) Attach the cable release to the cable release socket by screwing the threaded end of the cable release into the socket.

EXERCISE

43. To insure that the selected lens will be secured properly to the lens board mounting plate, you must use the _____.

5-9 Coarse Focusing Procedure

a. Attach the focusing cloth under the two focusing cloth clips (figure 5) on the top sides of the rear frame.

b. Depress the cocking lever (figure 7) until it latches in the cocked position.

c. Set the lens opening selector to the lowest f/number on the f/stop scale to provide maximum lens opening during focusing.

d. Remove the front lens cap from the lens.

e. Depress the focus button to open the shutter.

NOTE: The shutter will remain open until the cocking lever is depressed.

f. Loosen the front and rear carriage lock knobs enough to allow the front and rear carriages to slide on the monorail bed when the front and rear carriage adjust knobs are rotated.

g. Increase the distance between the front carriage and rear carriage by turning the carriage adjust knobs until the objective or scene to be photographed appears on the ground glass.

h. To produce the desired image on the ground glass, the height, angle, and direction of the camera may have to be changed. Use the tripod controls [(1) through (4) below] as required.

(1) To initially adjust the camera height, loosen the leg thumbscrews (figure 6) and extend or retract the telescoping legs as required; tighten leg thumbscrews securely after height adjustment is made.

(2) For additional height adjustment, loosen the center lock post knob and slide the center post up or down as required. After obtaining the desired height adjustment, tighten the center post lock knob securely.

CAUTION: Always maintain a firm grip on the tripod control handle when loosening the tilt knob. Unless the camera is accurately balanced on the panhead, rapid tilting will occur with possible damage to camera or tripod.

(3) To adjust the degree of camera tilt, loosen the tilt lock knob and with the tripod control handle, tilt the camera to the desired angle. After obtaining the desired tilt adjustments, tighten the tilt lock knob securely.

(4) To change the rotational position of the camera, loosen the rotation lock knob and with the tripod control handle, rotate the camera to the desired angle; tighten the rotation lock knob securely after rotational adjustment is made.

EXERCISE

44. Which lens mechanism must you operate in order to open the lens shutter prior to starting the focusing steps?

(select best answer)

- a. Cocking lever.
- b. Rear carriage adjust knob.
- c. Tilt adjustment knob.
- d. Focus button.

5-10 Fine Focusing Procedure

The camera has provisions for raising, falling, swinging, and sliding tilts that can change the lens axis and film plane with respect to each other. To make maximum use of these provisions, refer to TM 11-401-2 and proceed as indicated in a through f below.

NOTE: The rising, falling, swinging, and sliding tilts provided on the camera, exceed the covering power of the lens and shutter assemblies supplied. Be careful when composing the subject on the ground glass not to exceed the covering power of the lens and shutter assembly in use to avoid cutoff at the corners.

a. To eliminate undesirable foreground or background from the photograph, raise or lower the lens board mounting plate (figure 7) by pushing in and rotating the spring-loaded pinion knob until the desired degree of elimination is achieved.

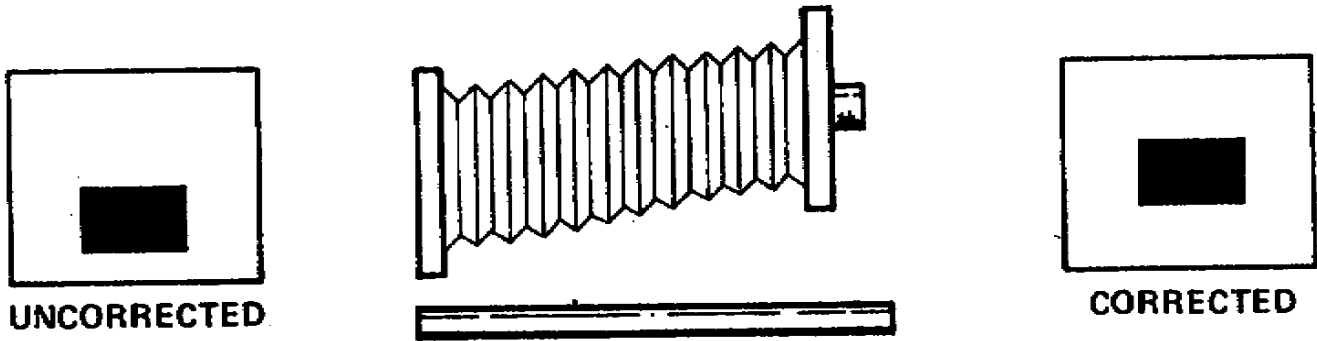

CENTERING IMAGE USING RISING / FALLING FRONT

b. After approximate focus has been obtained, slight changes in the image size on the ground glass may be obtained by moving the monorail bed with respect to the panhead as follows:

(1) Loosen the camera mount lock (figure 4) and turn the camera mount adjust knob (figure 5).

(2) After positioning the camera with respect to the subject, tighten the camera mount lock.

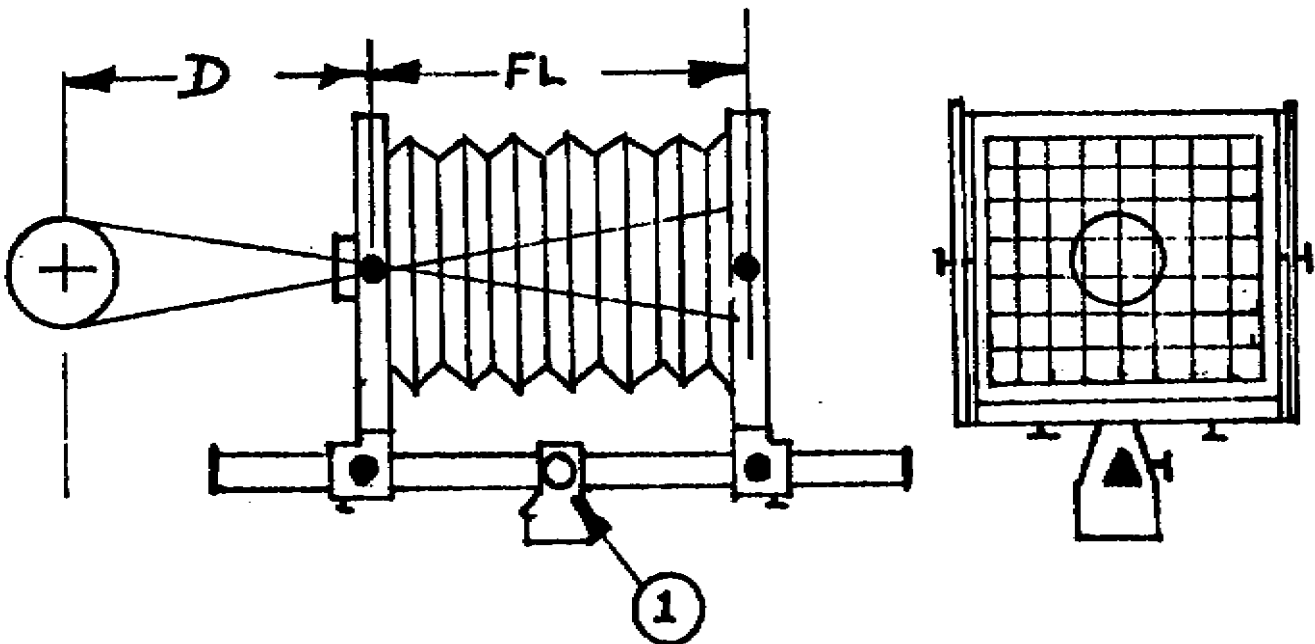

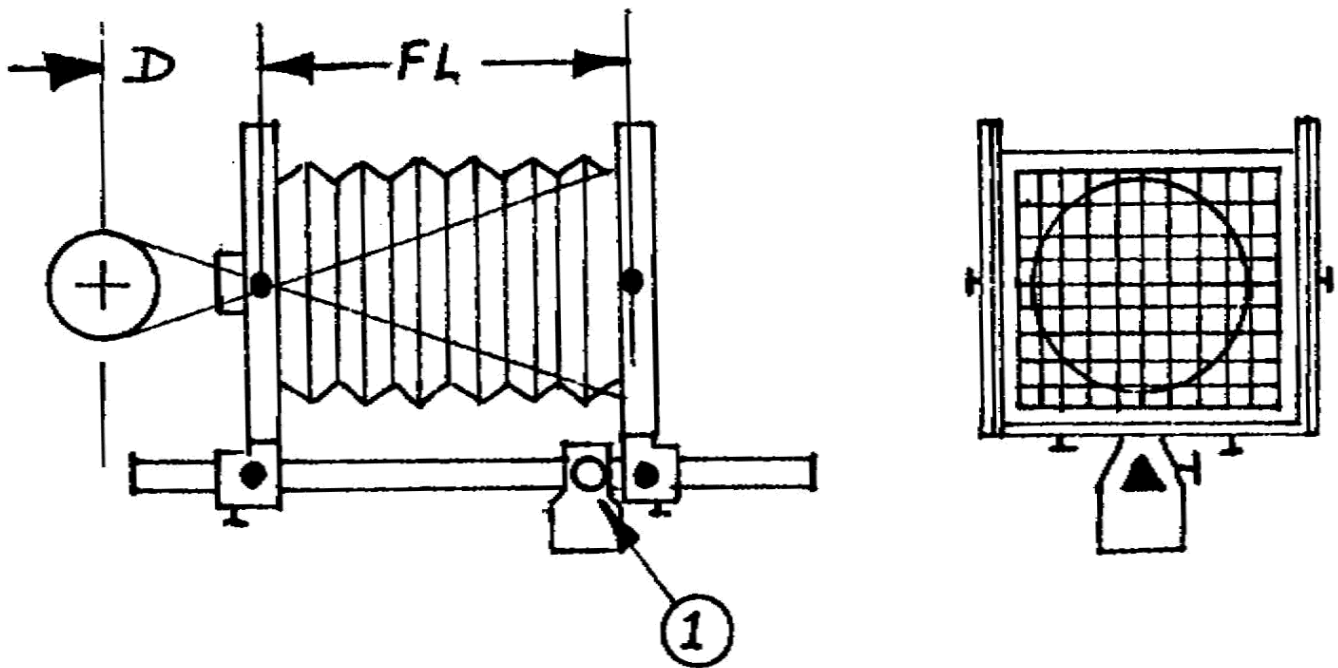

NOTE: Since the front and rear carriages are secured to the monorail bed, the distance between them is NOT changed by the rotating camera mount adjust knob.

c. When the camera cannot be centered horizontally with respect to the subject because of an obstruction, centering of the subject on the ground glass may be obtained by sliding the front or rear frame or both with respect to its carriage. Slide the front or rear frame as follows:

- (1) Loosen the respective slide and swing lock knob.
- (2) Gently slide the front or rear frame to the right or left as desired on its respective carriage.
- (3) After the adjustment is made, tighten the respective slide and swing lock knob.

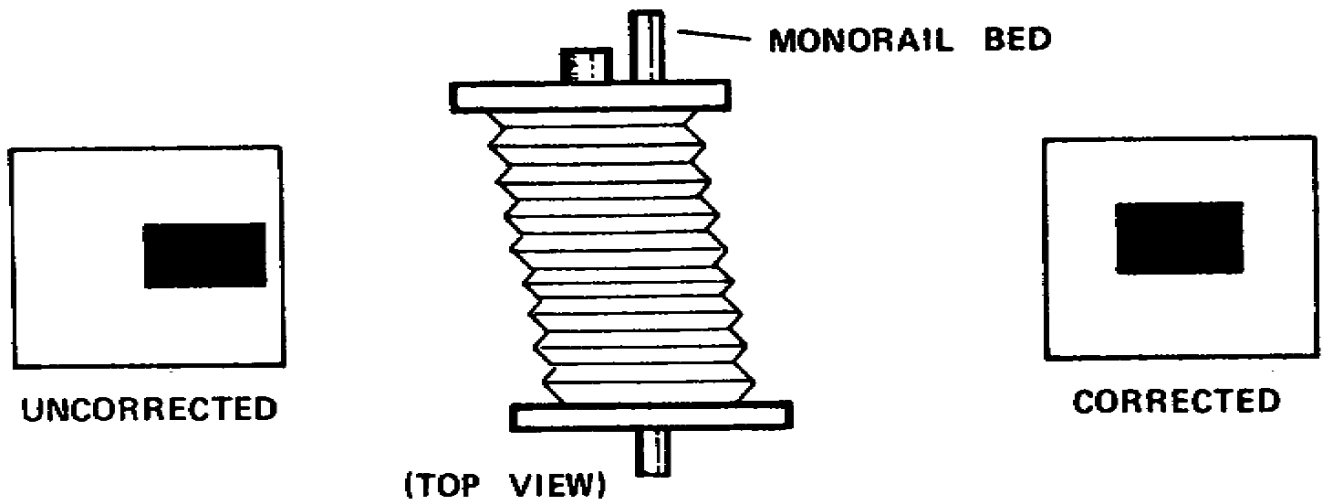

CENTERING IMAGE USING CARRIAGE SHIFT KNOB

d. To place the plane of sharp focus of the lens in the most advantageous relationship to the subject, use the swings and tilts of the front frame. Tilt the camera front as follows:

- (1) Loosen the front pivot lock knob (figure 4).

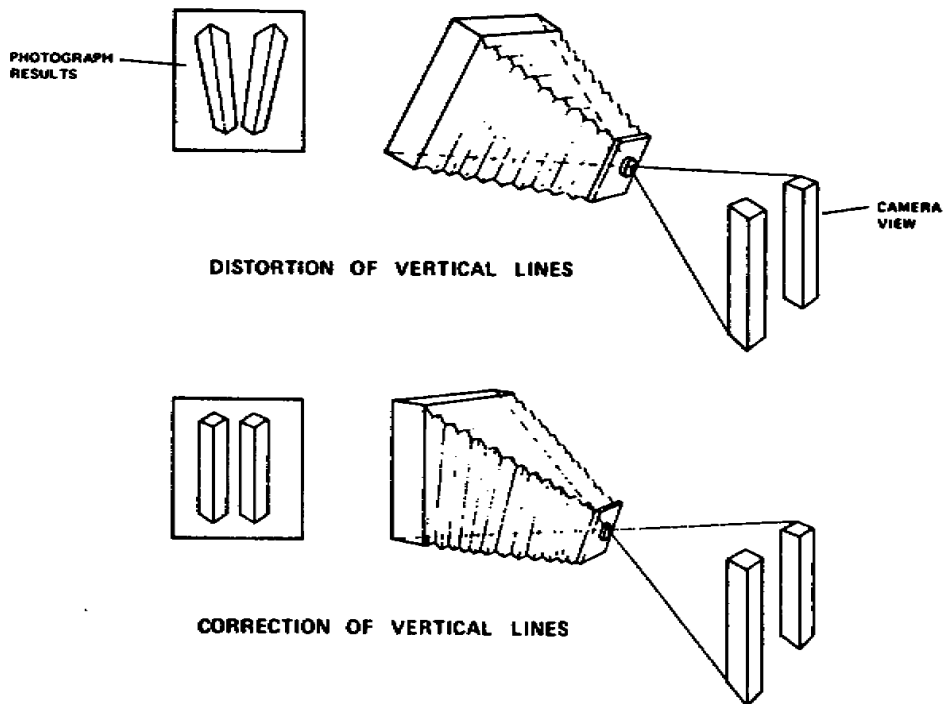

(2) Tilt the front forward or backward to the angle desired.

(3) After the tilting adjustment is made, tighten the front pivot lock knob.

(4) Loosen the front slide and swing lock knob.

(5) Grasp the front frame (figure 5) near the base and rotate it on the front carriage to the desired angle.

(6) After positioning the front frame, tighten the front slide and swing lock knob securely.

e. The rear frame has similar swinging and tilting provisions to permit correction for converging and diverging horizontal and vertical lines. The method of adjusting the rear frame is the same as described in d above, except that the rear controls are used.

NOTE: Detents are provided to indicate when the front and rear frames are in the normal perpendicular and swing positions with respect to the monorail bed.

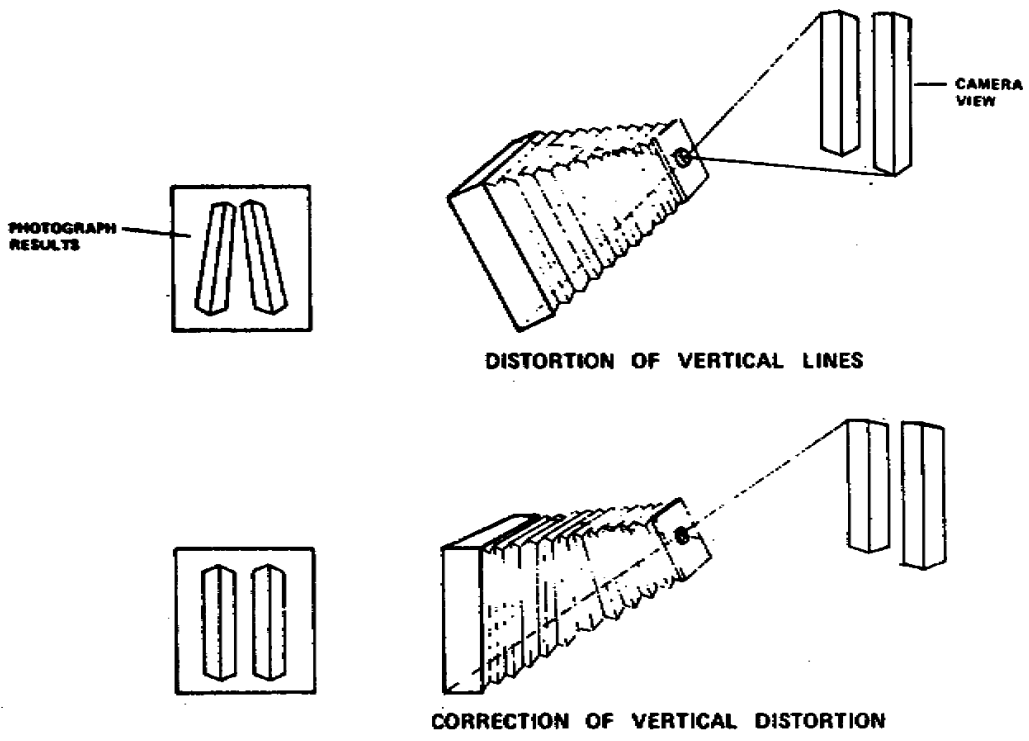

f. Changes in the orientation of the subject with respect to the long and short dimensions of the film may be made by rotating the revolving back. Rotation of the revolving back also permits more advantageous use of the film area when photographing long narrow subjects. The revolving back may be rotated in either direction through 360° and locked in any position. Detents are provided at each 90° point.

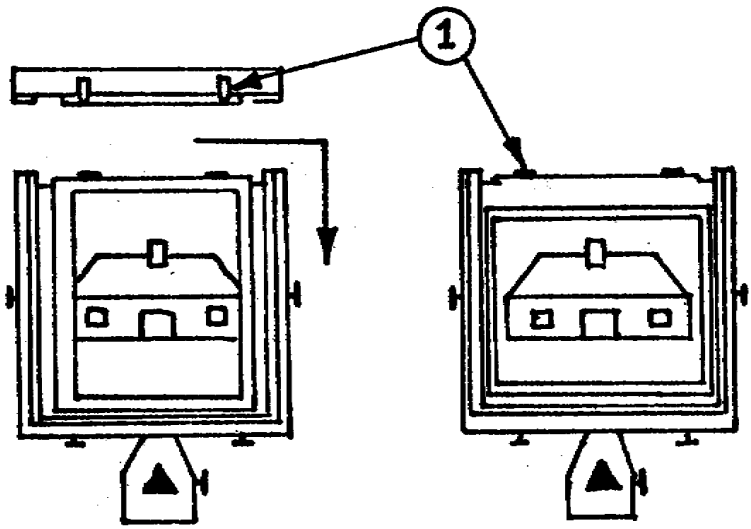

Rotate the revolving back as follows:

(1) Rotate the back lock crank to the right to release the locking mechanism.

(2) Grasp the pressure back near the outer edges and rotate the entire assembly to the desired position.

(3) Rotate the back lock crank to the left to lock the revolving back securely in position.

EXERCISE

45. You have just fine focused the image on the ground glass, but there is too much left over space above the image; in order to correct this you must perform the following steps:

ANS: _____

46. The image is centered and in approximate focus, but there is a lot of wasted space all around it. How can you correct this without changing the camera selected focal length and not move the tripod from where it stands?

ANS: _____

47. To place the plane of sharp focus of the lens in the most advantageous relationship to the subject, what camera movement should you use to correct for this?

ANS: _____

48. You are lining your camera up so you can make the best presentation of a large tank. You like the angle of viewing, but the image on the ground glass (vertical) is too wide; you are losing the outer edges of the tank. You can you correct for this, without moving the camera and tripod?

ANS: _____

5-11 Lens and Shutter Assembly Adjustments

a. After completing the focusing procedures, depress the cocking lever (1) to close the shutter.

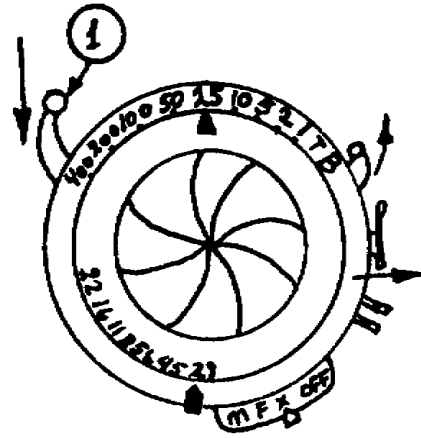

b. Rotate the speed selector ring (2) until the fiducial mark is opposite the desired shutter speed on the speed scale.

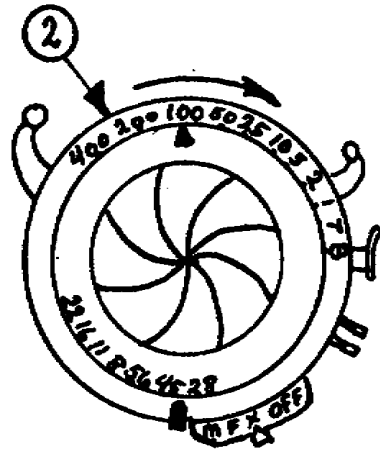

c. Move the lens opening selector until its pointer (3) is opposite the desired f/stop number on the f/stop scale.

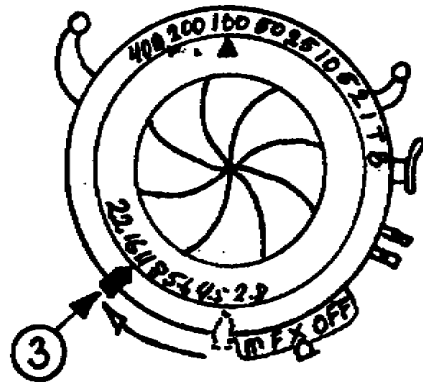

d. When a filter is required (TM 11-401-2), insert the filter in the filter and shade adapter and attach the adapter over the front of the lens.

NOTE: The lens shades may be screwed also into the filter and shade adapter for attachment to the lens either with or without a filter.

5-12 Inserting Cut Film Holder or Film Pack Adapter

The spring-loaded pressure back (figure 5) has an attached back lift handle or finger pads to facilitate insertion of the cut film holder or the film pack adapter. Insert the cut film holder or the film pack adapter as follows:

a. Pull the back lift handle or finger pads outward until there is approximately 1 inch between the pressure back and the frame of the revolving back.

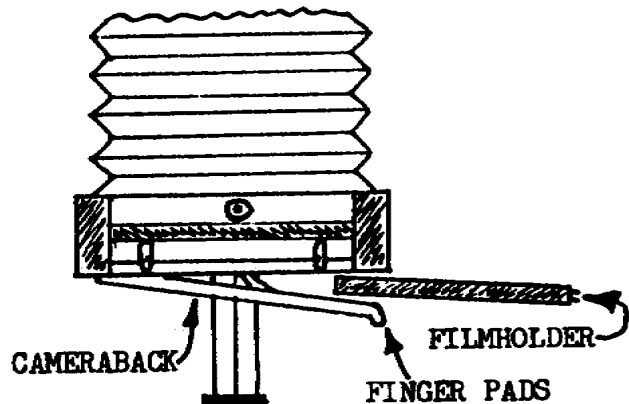

b. Insert the cut film holder or film pack adapter into the space between the pressure back and the camera back. Make sure that the cut film holder or the film pack adapter is pushed in as far as it will go, thus assuring a lighttight closure.

CAUTION: Do not allow the pressure back to snap closed from the open position without a cut film holder or film pack adapter in position. The ground glass may snap closed with sufficient force to break the ground glass or other parts.

c. Lower the pressure back against the cut film holder or film pack adapter by lowering the back slowly.

NOTE: While operating the pressure back, steady the rear frame with one hand while inserting the cut film or film pack holder. This will prevent possible shift in the camera position or adjustments.

EXERCISE

49. Which of the following items (components) must you manipulate when you want to set the correct shutter speed on the lens? (circle answer)

- | | |
|---------------------------|-------------------------|
| a. cocking lever. | c. fiducial mark. |
| b. lens opening selector. | d. speed selector ring. |
-

50. Why should you support the camera rear frame, while you are inserting a cut film holder or film pack adapter into the camera?

ANS: _____

In the just completed section, we have covered the identification, function and operating of the various parts and components of the KS-17A. This will not make you an expert on the operation of the KS-17A, but does give you the basic knowledge needed to operate the camera. But only through constant training and some supervision will you become better in order to produce top notch products.

SECTION 6

OPERATOR'S PREVENTIVE MAINTENANCE

6-1 Scope of Operator's Preventive Maintenance

a. Operator's maintenance for the camera set consists of the following:

- (1) Preventive maintenance.
- (2) Visual inspection.
- (3) Cleaning.
- (4) Troubleshooting.

b. No special tools or test equipments are required for operator's preventive maintenance.

6-2 Materials Required

The following items are required by the operator to perform preventive maintenance.

- a. Lint-free cloth (QM-27C-11565-36).
- b. Lens tissue (FSN 6640-393-2090).
- c. Lens cleaner (FSN 6760-408-5175).
- d. Camel's hair brush.
- e. Hand blower (air syringe).
- f. Cleaning compound, legend form (FSN 7930-395-9542).

WARNING: Prolonged breathing of cleaning compound is dangerous. Make sure that adequate ventilation is provided. Cleaning compound is flammable; do not use near an open flame.

6-3 Preventive Maintenance

a. DA Form 2404 (Equipment Inspection and Maintenance Worksheet) is used for recording equipment faults found during the operator's inspection, periodic maintenance services, inspection of equipment by maintenance activities, diagnostic checkouts and spot check inspection of equipment.

b. Use of DA Form 2404. The following sample copy of the 2404 will explain the primary use of the form and explain what information goes in the various blocks and columns. Each item of interest is numbered and explained in separate paragraphs.

(1) General instruction for preparation.

(a) Block 1. Enter the organization designation of the unit to which the equipment belongs.

(b) Block 2. Enter the noun nomenclature and model of the equipment.

(c) Block 3. For serial numbered equipment, enter item serial number.

(d) Block 5. Enter current calendar date, on which equipment faults were found, otherwise leave blank.

(e) Block 6. Enter the type of inspection or service to be performed (operator's daily, monthly, or quarterly service, etc.).

(f) Block 7. Enter the TM number and date of the manual pertaining to the item of equipment being inspected. When a change or changes to the manual has/have been published, enter the manual number followed by "w/c" and the latest change number. Enter the date of the latest change.

(g) Blocks 8a and 8b. Upon completion of an inspection, the inspector (operator) will enter his signature, rank, and time signed.

(h) Column a. Identify each uncorrected fault entered in column c by the TM item (sequence) number which identifies the prescribed check in the preventive maintenance checks and services (PMCS) (table of the technical manuals) used in the inspection.

(i) Column b. Enter the condition status symbol for all uncorrected faults. Status symbols are defined in paragraph 4-2c, TM 38-750 w/c 2. Upon correction of a fault entered in column c, the person correcting the fault will place his last name initial over the status symbol.

(j) Column c. At the start of a duty day, the equipment operator will enter the date in column 10c. Upon completion of the after-operation check, the operator will initial column c to denote that no uncorrected faults were found on the item of equipment.

c. For further explanation and maintenance procedures, you must refer to your unit SOP and unit maintenance section. Paragraph b above only briefly covers the usage of the DA Form 2404 which you will be using as the operator of a photographic equipment.

EXERCISE

51. Which of the following items listed is NOT a preventive maintenance step? (circle answer)

- a. Shooting technique.
- b. Cleaning.
- c. Troubleshooting.
- d. Visual inspection.

52. When performing operator's preventive maintenance on a camera, you should select and use which of the following combination of material and equipment? (circle answer)

- a. Lint-free cloth.
Dirty old rags.
Camel's hair brush.
Blow torch.
- b. Lens tissue.
Cleaning compound.
Diesel fuel.
Sand paper.
- c. Camel's hair brush.
Lens tissue.
Hand blower (air syringe).
Lint-free cloth.
- d. Steel brush.
Lens tissue.
Lint-free cloth.
High-test gasoline.

53. What is the information that goes in block #2 on the DA Form 2404?

ANS: _____

6-4 Operator's Maintenance Procedure Checklist

a. The following listed items must be checked when performing operator's maintenance and the DA Form 2404 for listing of equipment faults found during maintenance procedures.

Item	Maintenance Procedure
1	<p>Remove dust and foreign matter from lenses and filter by cleaning as outlined in paragraph 6-6. Install front and rear lens caps after cleaning lenses. Clean lens mountings by wiping with lint-free cloth.</p> <p style="padding-left: 40px;"><u>CAUTION:</u> Do not attempt to disassemble lens to remove foreign matter between lens elements. If internal cleaning is required, refer equipment to higher echelon for correction.</p>
2	<p>Remove dirt, dust, moisture, or other foreign matter from bellows, metallic parts of camera, and tripod with lint-free cloth. If additional cleaning is required, refer to paragraph ____.</p>
3	<p>Operate camera component controls (paragraph 5-5) and tripod controls (paragraph 5-5). Check for excessive looseness or binding. Operate controls on the lens and shutter assemblies (paragraph 5-5) to assure smoothness and ease of operation. Refer equipment defects to higher echelon for correction.</p>
4	<p>Carrying case cover should close tightly and be held securely closed by hinged fasteners.</p>
7	<p>Do not attempt to disassemble equipment to inspect for corrosion, worn spots, roughness, or binding threads.</p>
8	<p>Determine that shutter (figure 7) is firmly attached to lens board and that lenses are secure in shutter.</p>

Item	Maintenance Procedure
9	Check for distortion in lens board (figure 7) and for proper seating in lens board mounting plate.
10	With lens and shutter assembly removed, blow out any foreign matter inside camera component with air syringe.

6-5 Performing Visual Inspection

a. Check the camera component for lighttightness through cracks or around loose parts. Also, check for damage to the bellows which will admit light to the camera interior. Any light leakage may fog the film and reduce the contrast in the final negative.

b. Check the shutter for lighttightness as follows:

(1) Hold the lens and shutter assembly with the lens between a light source and the eyes.

(2) Set the lens opening selector for largest opening position.

(3) Observe that no light is visible through the shutter blades or around any part of the lens mounting.

(4) At various speed settings, operate the shutter release lever slowly until the shutter trips. Observe that the shutter blades do not start to open before shutter tripping occurs.

(5) If any defect in shutter operation appears, refer the trouble to higher echelon for correction.

c. Inspect the camera set for presence of all components which comprise the set. Replace any missing components.

d. Inspect all finished parts for scratched or marred surfaces. Refer finish defects to higher echelon for repair.

e. Inspect lens elements and filters for chipped surfaces, cracks, and scratches. Replace defective components of the camera set with serviceable components.

6-6 Equipment Cleaning

a. Optical and glass surfaces.

CAUTION: Dust particles may contain abrasive particles as hard as or harder than the fluoride coating on the lens surface. Dust the lens carefully [(2) below] before attempting removal of fingerprints or any other foreign matter from the optical surfaces.

(1) Remove the front and rear lens caps from the lens and shutter assembly.

(2) Carefully remove all dust, dirt, and foreign matter from the exposed optical surfaces of the lens and shutter assembly, filters, and camera ground glass; use a camel's hair brush, air syringe, or a gentle blast of moisture-free compressed air.

(3) Slightly dampen a small wad (one sheet) of lens tissue with lens cleaner.

CAUTION: Do not use lens tissue that contains silicons to clean optical surfaces. Any residue deposit that would be left on the optical surfaces by this kind of lens tissue could affect the performance of the lens and filters.

(4) Gently wipe the exposed optical surfaces of the lens and filters with the moistened lens tissue; using a circular motion, start from the edge of the glass and work toward the center.

(5) Dry the cleaned areas with a fresh sheet of lens tissue; use the same circular motion described in (4) above.

(6) Clean the camera ground glass surface with a clean, lint-free cloth dampened with clear water. After cleaning, dry the cleaned area thoroughly.

(7) Install the front and rear lens caps on the lens and shutter assembly.

b. Mechanical surfaces.

(1) Clean all exposed parts of the equipment with a dry lint-free cloth.

(2) Use a camel's hair brush or an air syringe to remove dust and foreign matter from hard-to-reach parts on the equipment.

(3) If foreign matter cannot be removed from the mechanical parts of the equipment by normal dry wiping, use a lint-free cloth moistened with cleaning compound to remove stubborn grime. Wipe the cleaned parts with a clean dry lint-free cloth immediately after cleaning.

CAUTION: Do not allow cleaning compound to come in contact with optical surfaces. Use cleaning compound sparingly.

EXERCISE

54. You are performing operator's preventive maintenance on your camera equipment and you have found that the shutter mechanism does not work properly. In what column on the DA Form 2404 must you make the entry of this fault? (select one)

a. Column 7.

c. Block 2.

b. Column 10d.

d. Column 10c.

55. In order to safely remove dirt and dust from the optical lens elements of a camera, you should only use _____

(complete statement)

56. How do you correctly use the lens tissue when cleaning an optical lens?

ANS: _____

6-7 Operator's Troubleshooting Checklist

a. General. The operator's troubleshooting checklist helps to sectionalize and correct certain minor troubles. The corrective measures listed are those that the operator can perform. If the measures suggested do not restore the equipment to normal performance, troubleshooting and corrective action will be required by equipment maintenance personnel. When referring equipment to higher echelon for maintenance or repair, note on the DA Form 2404 what corrective measures were taken and how the equipment performed at the time of failure.

NOTE: Consult your unit maintenance section and local SOP on how to turn your equipment in for repair.

b. Procedure. Generally, the operator can troubleshoot the camera set by examining the processed negatives for obvious symptoms. Refer to the SYMPTOM column to locate the trouble indicated on the negative.

Symptom	Probable trouble	Correction
Film not exposed	Front or rear caps not removed	Remove front and rear lens cap.
	Dark slide (figure 8) not removed from cut film holder of film pack adapter	Remove dark slide prior to making exposure (para 5-12).
	Shutter (figure 7) not cocked	Cock shutter (para 5-12).
	Defective shutter (figure 7)	Refer equipment to higher echelon for repair.
Film under-exposed	Shutter speed too fast	Reset speed selector ring to proper shutter speed (para 5-11).

Symptom	Probable trouble	Correction
Film over-exposed	Lens opening selector (figure 7) incorrectly set	Reset lens opening selector to correct (larger opening) f/stop (para 5-11).
	Actual shutter timing is not indicated by fiducial mark (figure 7)	Refer equipment to higher echelon for repair.
	Lens opening selector (figure 7) incorrectly set	Reset lens opening selector to correct (smaller opening) f/stop (para 5-11).
	Shutter speed too slow	Reset speed selector ring to proper shutter speed (para 5-11).
Film scratched	Actual shutter timing is not that indicated by fiducial mark	Refer equipment to higher echelon for repair.
	Film improperly loaded in cut film holder	Load cut film holder (para 5-6) carefully.
Film fogged	Film improperly loaded in cut film holder or film pack adapter	Exercise care and observe safelighting procedures when loading cut film holder (para 5-6) or film pack adapter (para 5-6).
	Cut film holder or film pack adapter incorrectly inserted in camera	Insert cut film holder or film pack adapter in camera as indicated in para 5-12.

Symptom	Probable trouble	Correction
Processed film not sharp (image hazy or dif-fused)	Dark slide (figure 8) in cut film holder or film pack adapter im-properly removed or inserted	Keep dark slide straight; remove and insert dark slide smoothly.
	Camera, cut film holder or film pack adapter not lighttight	Refer equipment to higher echelon for correction.
	Camera moved during exposure	Steady camera during exposure.
	Camera not focused correctly	Refocus camera (para 5-9).
	Optical surfaces dirty	Clean optical sur-faces (para 6-6).
Under or overexposure (when photo-flash equip-ment is used)	Optical surfaces badly scratched	Refer equipment to higher echelon for repair.
	Shutter speed incor-rectly set	Reset shutter speed (para 5-11).
	Lens opening selector (figure 7) incorrectly set	Reset lens opening selector to correct f/stop setting (para 5-11).
	Synchronism adjustment wheel (figure 7) in-correctly set	Reset synchronism adjustment wheel.
	Synchronization cock-ing lever (figure 7) not cocked prior to shutter operation	Cock synchronization cocking lever before operating shutter.
	Synchronization mecha-nism defective	Refer equipment to higher echelon for repair.

This completes the lesson on the KS-17A Camera Set. We have talked about some basic operation steps and how to perform the operator's preventive maintenance. This will by no means make you or anybody else an expert on this camera set, but with this information and a lot of hard work you will be able to achieve a much better result and you will be commended and awarded for your performance, but you have got to work at it.

SECTION 7

CAMERA SET, STILL PICTURE KS-99C

THE OPERATION OF CAMERA SET, STILL PICTURE KS-99C IS COVERED IN TEC LESSON NO. 832-113-9003F. THE TEC LESSON CAN BE OBTAINED FROM YOUR LOCAL LEARNING CENTER.

THIS SECTION WILL ONLY COVER THE OPERATOR'S PREVENTIVE MAINTENANCE.

7-1 Preventive Maintenance Checks and Services

Purpose: Preventive maintenance checks and services (PMCS) is the systematic care, service, and inspection of equipment to insure that the equipment is serviceable and to prevent the occurrence of trouble.

a. Operator's maintenance consists of the following:

- (1) Daily and monthly preventive maintenance.
- (2) Troubleshooting.
- (3) Cleaning.

b. Repair of the still picture camera components is not authorized at operational level. If correction or repair is required, refer the equipment to the next level of maintenance.

7-2 PMCS Period, Reporting, and Procedures

a. PMCS Periods. Preventive maintenance checks and service table 7-1 lists checks to be performed daily when camera set is in use. If the camera set is not used daily,

it should be checked and serviced immediately before being put to use and as soon after being used as possible. When not in regular use, do NOT allow the camera set to go beyond one week without performing the daily preventive maintenance checks and services.

b. PMCS Reporting. Record all checks in accordance with TM 38-750 w/c 2.

c. PMCS Procedures. Table 7-1 lists procedures for performing PMCS. The first column lists the interval and sequence that a particular check or service is required. This column is subdivided into two columns: D (daily) and M (monthly). The second column lists the item to be inspected and the procedures. For detailed information on performing the inspections, refer to paragraphs 8-1, 8-2, and 8-3.

7-3 Tools and Material Required

No tools are required for operator's maintenance. The material required are listed below.

NSN	ITEM	USE
7920-00-356-4694	1-inch bristle brush	Clean metal surface
8020-00-246-8806	Camel's hair brush	Clean glass surfaces
8305-00-267-3015	Lint-free cloth	Clean metal surfaces
8305-00-170-5062	Lens tissue	Clean glass surfaces
6750-00-408-5175	Lens cleaner (liquid)	Clean glass surfaces

Table 7-1. Preventive Maintenance Checks and Services

D - daily

Time required: 4

M - monthly

Time required: 1.2

INTERVAL AND SEQUENCE NO.		ITEM TO BE INSPECTED PROCEDURE	WORK TIME (M/H)
D	M		
1		<u>CAMERA SET.</u> (figure 1-20) Check to see that Camera Set KS-99C is complete IAW packaging list.	0.1
2		<u>CAMERA BODY EXTERIOR SURFACES</u> a. Check for physical damage. b. Remove dust, dirt, and moisture with a clean, lint-free cloth.	0.1
3		<u>EXTERIOR SURFACES OF LENSES AND FILTERS</u> a. Check for physical damage. b. Clean metal and optical surfaces if required.	0.1
4		<u>OPERATION</u> a. During operation, be alert for any unusual conditions. b. Listen for unusual sounds when winding, rewinding, and operating shutter release. c. Feel for binding of controls and film winding lever.	0.1
	5	<u>CAMERA BODY</u> (figure 1-21) a. Check back cover hinge and lock to be sure that they are not loose. b. Check operation of shutter at each speed setting. c. Check shutter speed control for tightness and for alignment of numbers with index.	0.3

Table 7-1. Preventive Maintenance Checks and Services (cont)

D - daily
Time required: 4

M - monthly
Time required: 1.2

INTERVAL AND SEQUENCE NO.		ITEM TO BE INSPECTED PROCEDURE	WORK TIME (M/H)
D	M		
	5	d. Check frame counter for correct operation. e. Check to see that depressing safety stopper allows film rewind knob to be lifted up. Check that back cover opens slightly when knob is lifted all the way up. f. Load film in camera. Check film transport for smooth winding and rewinding. g. Check operation of self-timer. h. Check to see that lens mounting surface is smooth.	
	6	<u>LENSES</u> a. Check operation of focusing mount. b. Check operation of diaphragm ring.	0.7
	7	<u>FILTERS</u> Check mounting threads for damage.	0.1
	8	<u>CABLE RELEASE</u> a. Check operation. b. Inspect threads.	0.1
	9	<u>LENS HOODS</u> Inspect lens hoods for cracks or other damage.	0.1

Table 7-1. Preventive Maintenance Checks and Services (cont)

D - daily

Time required: 4

M - monthly

Time required: 1.2

INTERVAL AND SEQUENCE NO.		ITEM TO BE INSPECTED PROCEDURE	WORK TIME (M/H)
D	M		
	10	<u>FLASH UNIT</u> a. Check condition of flash unit, AC/charge unit, on connecting cords. b. Remove dirt, dust, and moisture from the flash unit and AC/charge unit with a lint-free cloth.	0.2
	11	<u>CARRYING CASE AND MINOR COMPONENTS (figure 1-20)</u> a. Inspect all minor components for completeness and condition. Report any damage or shortage to organizational maintenance. b. Clean carrying case inside and outside. Remove all dirt, dust, and moisture with a clean, lint-free cloth dampened with water. Wipe dry.	0.3

EXERCISE

57. Which of the following TM's outlines the procedures for recording all the maintenance checks you will do on the KS-99C Camera Set? (select one)

- a. TM 11-401-1.
- b. TM 38-750 w/c 2.
- c. TM 11-6720-253-10.
- d. TM 750-5-5.

58. What are the two intervals at which you must do preventive maintenance checks and services?

ANS: _____ and _____.

7-4 Troubleshooting

General. This section contains troubleshooting information for locating and correcting most of the operating troubles which may develop in the camera set. Each malfunction in Table 7-2 is followed by a list of tests or inspections which will help you to determine probable causes and corrective actions for you to take. You should perform the tests/inspections and corrective actions in the order listed. Repair of camera components is NOT authorized at operational level. If corrective maintenance or repair is required, refer the camera set to the next higher category of maintenance.

a. Unlisted malfunctions.

(1) This subcourse cannot list all possible malfunctions that may occur, or all tests or inspections and corrective actions. If a malfunction is not listed (except when malfunction and cause are obvious), or is not corrected by listed corrective actions, notify your supervisor.

NOTE: Before you use this table, be sure you have performed all applicable checks.

Table 7-2. Troubleshooting

MALFUNCTION	TEST OR INSPECTION	CORRECTIVE ACTION
CAMERA		
1. VIEWFINDER AREA IS DARK.	Step 1. Check to see that lens cap was removed. Remove lens cap.	
	Step 2. Check to see that mirror is not locked in up position (figure 1-23).	Unlock mirror by turning lever lock/mirror lock lever as far toward lens mount as possible.
2. VIEWFINDER AREA IS CIRCULAR AND DOES NOT FOCUS PROPERLY.	Check to see that viewfinder screen was installed after cleaning (figures 1-29 and 1-30).	Put viewfinder screen in correct position.
3. NO EXPOSURE.	Step 1. Check to see that film is properly loaded in camera (figures 1-26 and 1-27).	Load film properly.
	Step 2. Check to see that film is not defective.	Use good quality film.
4. IMPROPER EXPOSURE.	Step 1. Check camera battery.	If battery condition indication is low, replace battery.
	Step 2. Check to see that film speed dial setting matches rating of film loaded in camera (figure 1-28).	
5. FILM WILL NOT ADVANCE.	Step 1. Check to see that film is properly loaded in camera (figures 1-26 and 1-27).	Load film properly.
	Step 2. Check to see that film is not past last exposure.	If film is past last exposure, rewind film.

Table 7-2. Troubleshooting (cont)

MALFUNCTION	TEST OR INSPECTION	CORRECTIVE ACTION
(cont)	Step 3. Check cartridge spool.	If spool does not rotate, obtain a new cartridge and load the camera.
6. FILM CANNOT BE REWOUND.	Step 1. Check to see that the film rewind button has been pressed (figure 1-22).	Press the film rewind button and rewind the film.
	Step 2. Check to see that the film has not been pulled off the supply spool.	If the film has been pulled off the supply spool, take the camera into a darkroom or changing bag. Then unload the camera and rewind the film onto the cartridge by hand.
7. METER INOPERATIVE.	Check camera battery.	If camera battery condition indication is low, replace battery (figure 1-22).
8. SCRATCHES ON NEGATIVE.	Check to see that the camera film path is free of dirt and dust (figure 1-25).	If dust or dirt is present, clean the camera with a lint-free cloth or soft brush.
9. LIGHT LEAKS ON FILM.	Step 1. Check to see that the back cover is completely closed (figure 1-25).	If the cover is not closed, insure that the cover hook is inserted in its slot in the camera body and that the cover latches with an audible click when it is pressed in place.

Table 7-2. Troubleshooting (cont)

MALFUNCTION	TEST OR INSPECTION	CORRECTIVE ACTION
(cont)		
Step 2.	Check to see that the back cover was not opened before the film was rewound.	Exercise care not to open the back cover before the film has been completely rewound.
FLASH UNIT		
10.	FLASH UNIT DOES NOT FIRE WHEN READY LIGHT IS ON AND SHUTTER RELEASE IS PRESSED.	
Step 1.	If flash unit is mounted on camera, check to see that the flash unit is securely fastened to flash adapter, that PC cord is connected to the hot shoe PC terminal (receptacle on flash unit) and that adapter is pushed as far toward the front of the camera as possible (figure 1-23).	
	If these conditions are not satisfactory, attach the flash unit to the camera correctly.	
Step 2.	If flash unit is hand-held, check to see that cords are securely connected to camera and flash unit.	
	If these conditions are not satisfactory, connect the cord properly.	
11.	FLASH UNIT READY LIGHT DOES NOT COME ON WITHIN 1 MINUTE AFTER PLUGGING UNIT INTO AC OUTLET.	
Step 1.	Check to see that outlet has power. If there is no power, use another outlet or switch to DC operation (figure 1-24).	
Step 2.	Check to see that ON-OFF switch is at ON. If switch is at OFF, move it to ON position.	

Table 7-2. Troubleshooting (cont)

MALFUNCTION	TEST OR INSPECTION	CORRECTIVE ACTION
(cont)	Step 3.	Check to see that AC/charge unit is properly connected to flash unit.
		If unit is not properly connected, plug AC/charge unit connector securely into AC/charge receptacle on flash unit.
	Step 4.	Insure that the flash unit capacitor is properly activated.
		Form (electrically activate) the capacitor.

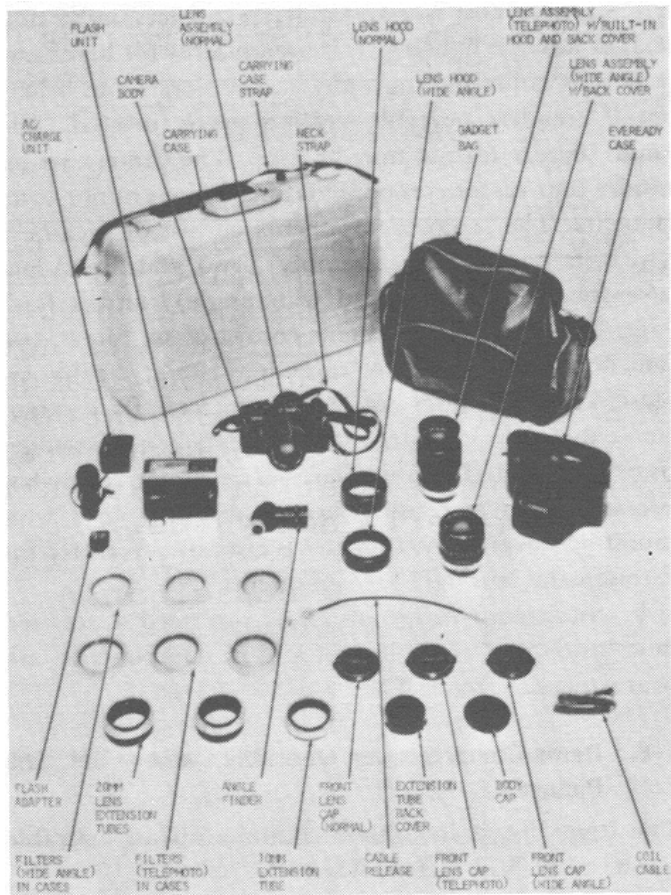

FIGURE 1-20. Camera Set, Still Picture KS-99C.

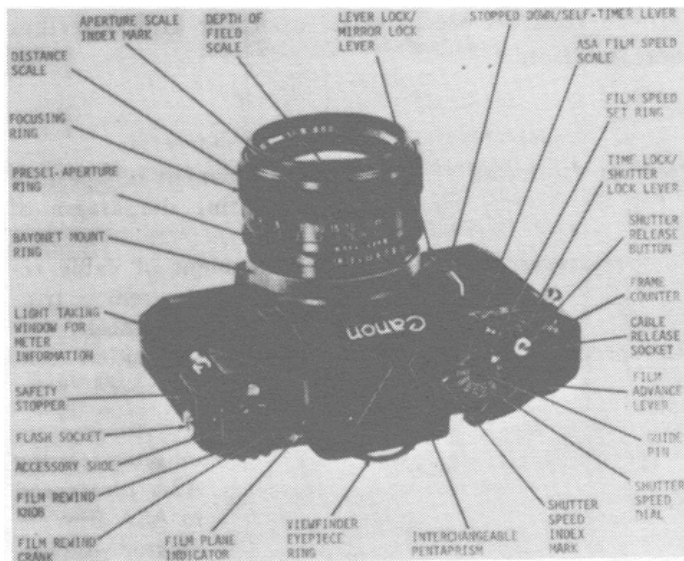

FIGURE 1-21. Camera controls and indicators, front top view.

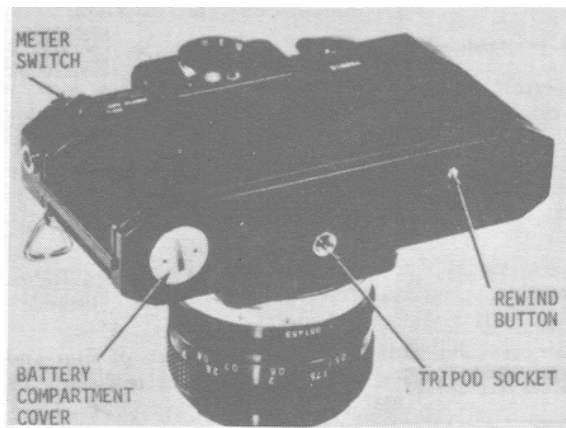

FIGURE 1-22. Camera (bottom view).

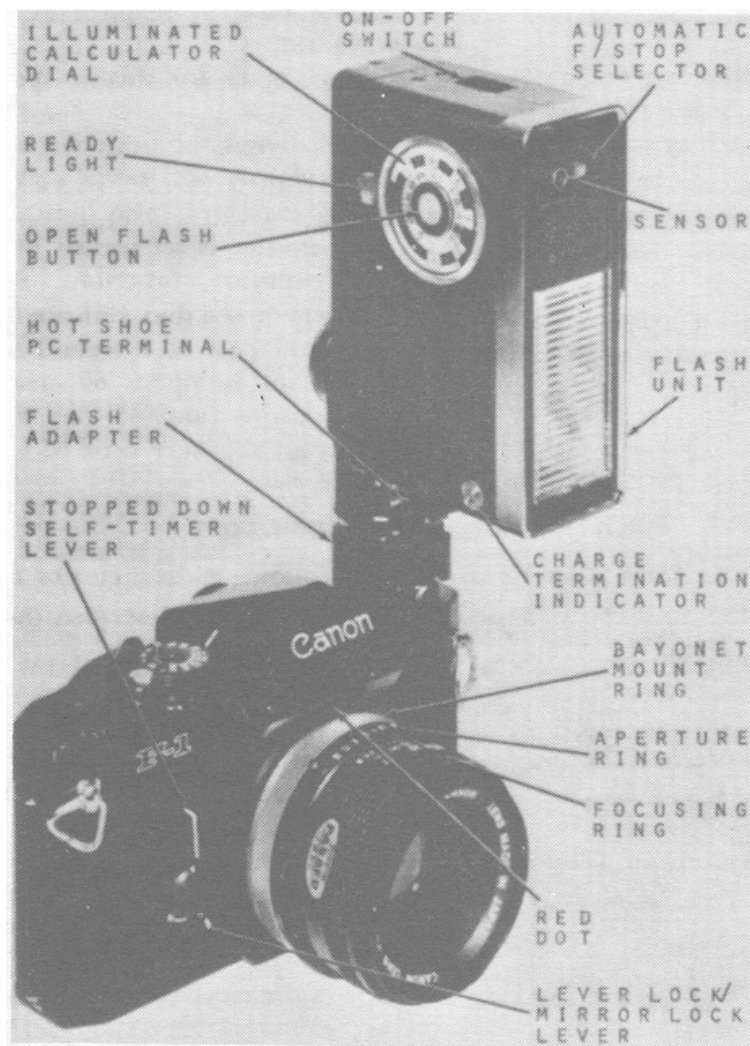

FIGURE 1-23. Camera with flash unit (front view).

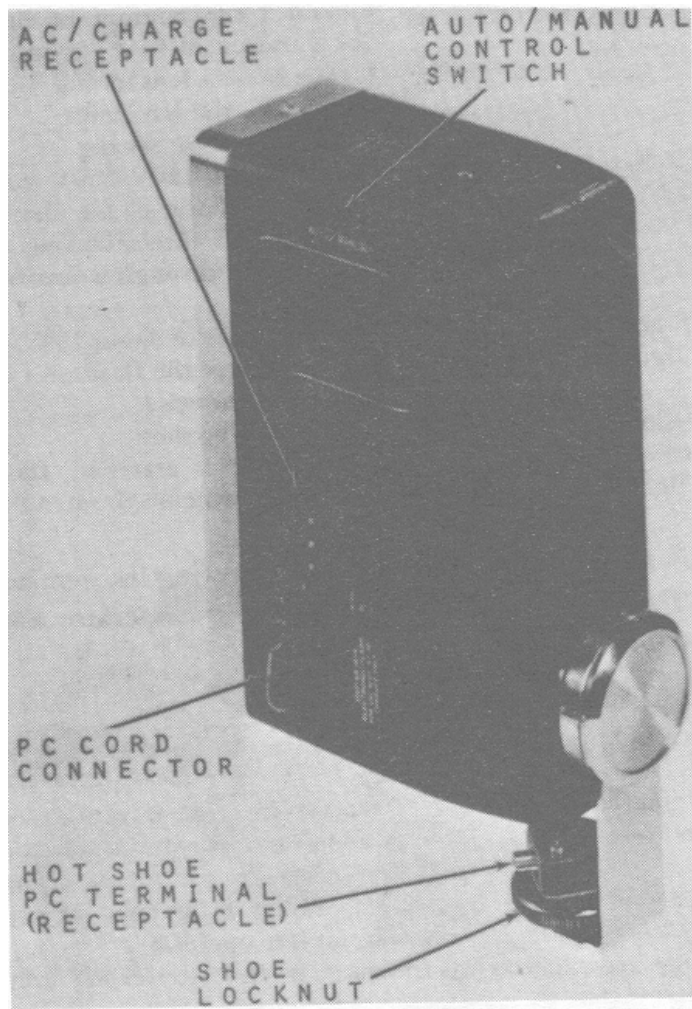

FIGURE 1-24. Flash unit (rear view).

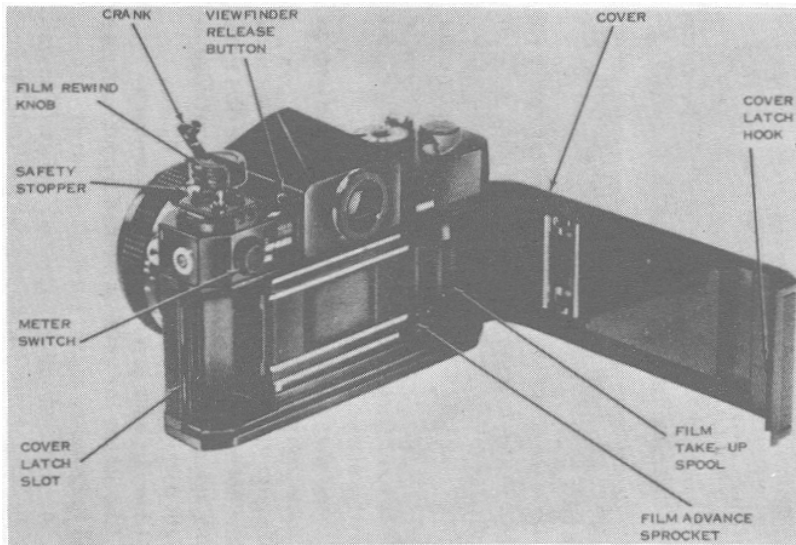

FIGURE 1-25. Camera with back open.

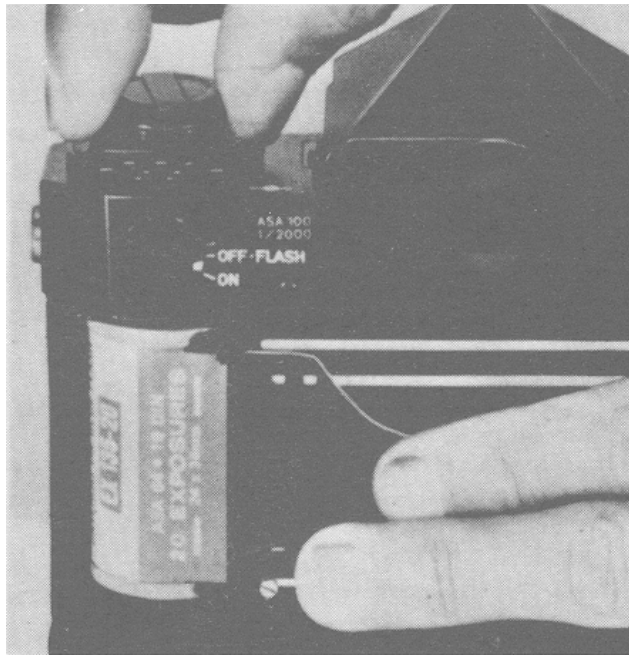

FIGURE 1-26. Inserting film in camera.

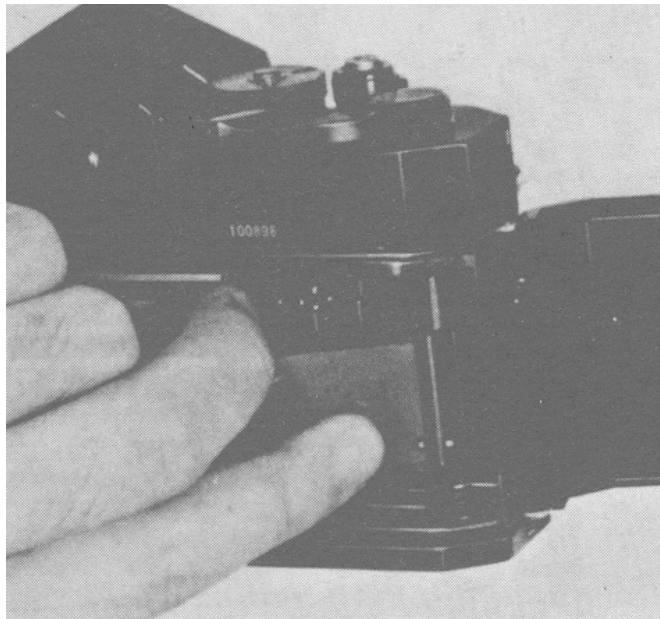

FIGURE 1-27. Engaging film in takeup spool.

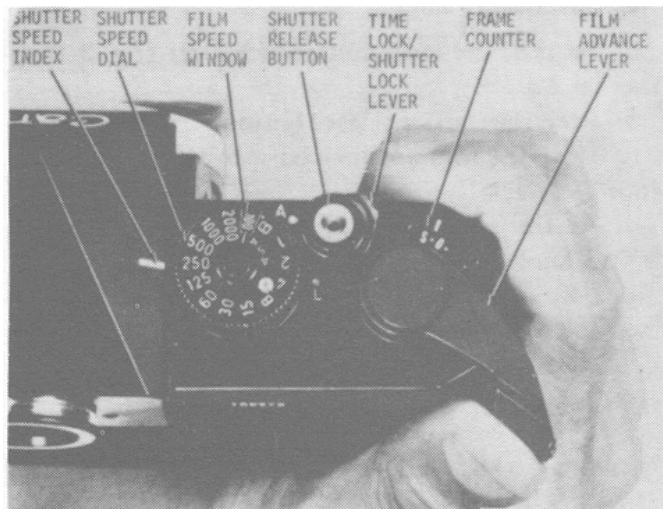

FIGURE 1-28. Winding film.

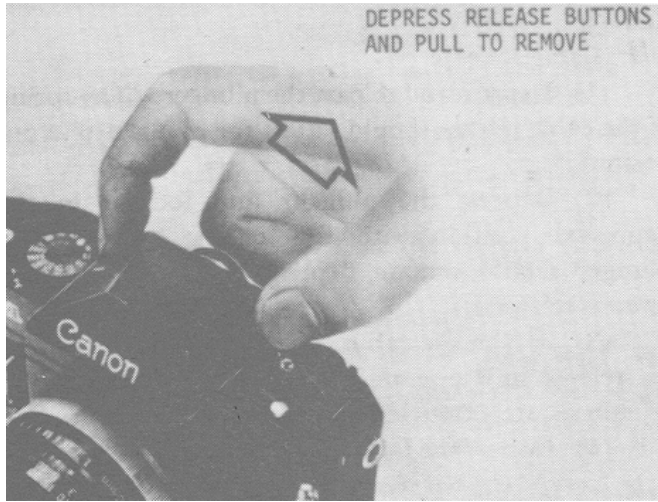

FIGURE 1-29. Removing pentaprism.

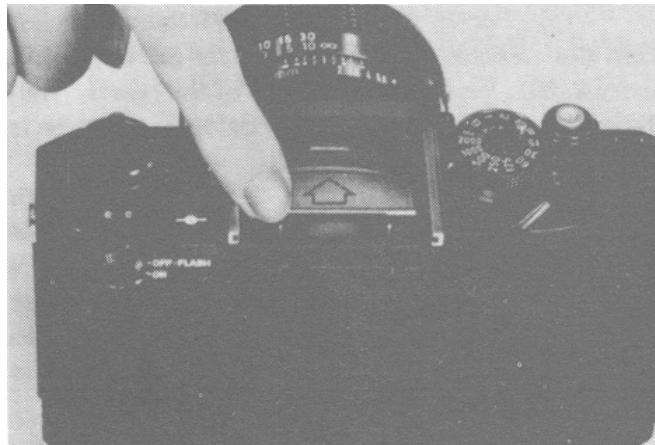

FIGURE 1-30. Removing viewfinder screen.

SECTION 8

MAINTENANCE PROCEDURES

8-1 Inspection and Operating Checks

NOTE: Rewind the film and remove it from the camera before carrying out the following procedures.

a. Interior.

(1) Remove the lens from the camera body.

(2) Lock the mirror up.

(3) Open the back of the camera.

(4) Remove the pentaprism by squeezing both release buttons (figure 1-29) with your fingers and sliding the pentaprism toward the rear of the camera.

(5) Remove the viewfinder screen by lifting up on the rear edge with your fingernail (figure 1-30). (There is a notch on each side to make this easier.)

(6) For easier cleaning of the viewing window, unscrew the eyepiece ring.

(7) Check the pressure plate (figure 125) for scratches, pits, and dirt; clean if required (para 8-2a(2)(b)).

(8) Check the interior of the camera body for dust, film clips, and foreign particles; clean if required (para 8-2a(2)(a)).

b. Shutter operation.

(1) Remove the lens and open the back of the camera body as in a above.

(2) Point the camera body toward a light area and look at the rear of the shutter curtain.

(3) Turn the film advance lever until it stops and then press the shutter release button.

(4) Repeat this for each speed on the shutter speed dial.

(5) The shutter should open each time it is tripped.

c. Shutter speed control.

(1) Rotate the shutter speed dial throughout its range.

(2) Check that it is not loose. (Each indicated shutter speed should have a positive click and align with the shutter speed index.)

d. Frame counter.

(1) Turn the film advance lever until it stops and then press the shutter release button.

(2) Do this several times. (This frame counter should move one division each time the shutter is wound.)

e. Film rewind knob.

(1) Unfold film rewind crank and rotate it several turns.

(2) Check for smooth operation. (The film rewind fork, inside the camera body, should rotate as the rewind knob is turned.)

f. Self-timer.

(1) Wind the shutter.

(2) Turn the stopped-down/self-timer lever away from lens mount until it stops.

(3) Press the shutter release button. (The shutter should open after delay of approximately 10 seconds.)

g. Lens mounting flange.

(1) Check to see that the surface of the flange is smooth and free of dirt, nicks and burrs. (The mounting screws should be tight.)

(2) Mount a lens on the camera and lock it in position. (It should not bind while mounting. The lens lock should hold the lens securely.)

h. Film transport.

(1) Load the camera with film. (The film advance lever should operate smoothly and the film should not drag or bind.)

(2) Rewind the film. (Rewinding should be smooth and without binding.)

NOTE: To avoid waste, use a roll of outdated film if it is available.

i. Camera synchronization and flash unit circuit.

(1) Rewind and remove the film if the camera is loaded.

(2) Mount flash unit on the camera.

(3) Set the shutter speed dial to 60.

(4) Turn the flash unit on and wait approximately 5 seconds.

(5) Turn the film advance lever until it stops and then press the shutter release button.

(6) Do this several times. (The flash should flash each time.)

j. Lenses.

(1) Mount the lens on the camera body. (Mounting should be smooth and the lens should lock securely.)

(2) Rotate the focusing ring throughout its range. (Rotation should be smooth and free of binding.)

(3) Rotate the preset aperture ring throughout its range. (It should operate smoothly and without binding. Each aperture number and one intermediate position should have a positive click.)

(4) Check the filter mounting threads.

(5) Check self-storing lens hood on telephoto lens for freedom of movement and for physical damage.

k. Cable release.

(1) Depress and release the plunger. (The spring in the cable release should return the plunger to its out position.)

(2) Depress the plunger and lock it in the depressed position with the locking screw. (The plunger should remain depressed until the locking screw is released.)

(3) Attach the cable release to the camera shutter release and operate it several times. (It should remain securely fastened.)

(4) Inspect the fabric covering for signs of wear.

1. Lens hoods for normal and wide angle lens.

(1) Inspect the lens hoods for damage.

(2) Mount the lens hoods on the lenses. (They should mount securely.)

m. Eveready case.

Inspect the interior and exterior of the case for damage. (The snap fasteners should hold the cover in the closed position.)

n. Neck strap.

(1) Check to see that the neck strap is free of breaks and tears.

(2) Check to see that the fasteners lock securely on the camera body.

EXERCISE

59. Your viewfinder gives you a circular image (round corners) and unclear focus. This is due to which of the following faults? (select one answer)

a. The wrong lens hood.

b. Improper focusing.

c. Viewfinder screen improperly installed.

60. Which of the following items should be checked because your build-in light-meter does not give you a light-meter reading?

- a. ASA setting, f/stop.
- b. Battery and meter switch.
- c. Battery.
- d. Lens cap on lens.

61. When checking the synchronization of the flash unit and the camera, what is the correct shutter speed setting?

- a. 1/250 sec.
- b. 1/60 sec.
- c. 1/25 sec.
- d. 1/125 sec.

8-2 Cleaning

CAUTION: Do not use cleaning materials other than those authorized.

Cleanliness is essential for proper operation and preservation of precision photographic equipment. Dirty or scratched lens surfaces will seriously affect the quality of the photograph.

a. Camera body.

(1) Exterior.

(a) Metal surfaces and body covering. Remove the lens from the camera. Brush the camera body with a soft bristle brush and wipe it with a clean, lint-free cloth.

NOTE: A small stick with lens tissue or cotton on the end may be used in areas otherwise inaccessible.

(b) Optical surfaces. Clean the illuminating window, viewfinder screens, viewfinder prism, and eyepiece. Follow the procedure for cleaning lens in (2) below.

(2) Interior.

(a) Transport mechanism. Remove the lens from the camera. Lock the mirror in the up position. Swing open the back of the camera body. Blow out any dust or foreign matter that may be inside the camera body.

(b) Pressure plate (figure 1-25). Gently wipe the surface of the pressure plate with a clean piece of lens tissue. If further cleaning is required, moisten a piece of lens tissue with lens cleaner and wipe the pressure plate. Remove any moisture with a piece of dry lens tissue.

b. Lenses.

(1) Metal surfaces. Clean the outside metal surfaces of the lens. Follow the procedure for exterior cleaning as described in a(1) above.

CAUTION: Dust particles are abrasive and can damage optical surfaces. Fingermarks and other foreign matter should be removed carefully as soon as possible. Do NOT use tissue or cloth intended for eyeglass cleaning. Such materials usually contain silicone which will leave a deposit damaging the coating of the lens. Do NOT use more lens cleaner than necessary to moisten the lens tissue. Excess liquid may seep between the elements, dissolve the binding medium, and damage the lens.

(2) Optical surfaces.

(a) Front surface. Brush the surface with a clean camel's hair brush. If further cleaning is required, breathe lightly on the surface and wipe with a clean piece of crumpled lens tissue. If foreign matter still remains, moisten a piece of lens tissue with lens cleaner and wipe the surface. Remove any moisture with a fresh piece of lens tissue.

(b) Rear surface. Clean the rear surface as described in (a) above.

(c) Eveready case. Wipe down the interior and exterior surfaces with a clean, lint-free cloth. Remove dirt from around the snaps. Blow dust from inside the case. If necessary, the exterior of the case may be cleaned with a damp cloth and mild soap. Remove all soap with a clean damp cloth.

8-3 Flash Unit

a. Changing battery.

NOTE: Change the flash unit battery before and after each use. Also charge the battery whenever it takes more than 30 seconds for the ready light (figure 1-23) to come on again after flashing.

(1) Insure that the battery ON-OFF switch on the flash unit is set at OFF.

(2) Insure that the AC/charge unit VOLTAGE SELECTOR IS SET FOR THE AC line voltage available.

(3) Plug the AC/charge unit into an ac receptacle.

(4) Connect the AC/charge unit cord to the flash unit.

NOTE: A full charge should take approximately 1 hour; variations in charging conditions may cause full charging to take up to 1 1/2 hours. You will get an average of 65+ flashes after the unit is fully charged. Shorter charging times will give you fewer flashes. On the average, you will get eight flashes from 5 minutes of charging and 20 flashes from 15 minutes.

(5) Charge unit until charge termination indicator (figure 1-23) glows.

NOTE: Unplug AC/charge unit when the AC/charge unit is unplugged from a power source. Failure to do so will allow the flash unit battery to discharge.

b. Forming capacitor.

NOTE: The capacitor in the flash unit must be formed (electrically activated) whenever the unit has not been used for 30 days or more. Do this after the battery has been charged.

(1) After the battery has been charged, leave the AC/charge unit connected to the flash unit, and slide the ON-OFF switch to ON.

(2) When the ready light comes on, fire the flash by pressing the open flash button (figure 1-23).

(3) When the ready light comes on again, press the switch.

(4) Do this for a total of five flashes.

In this lesson we have talked about the large format camera, and the 35 m/m SLR. You have been told something about how the cameras function; we have also talked about what you, the operator, must do in order to insure a smooth and trouble-free performance. This is known as operator's preventive maintenance checks and services (PMCS).

We are not telling you that you will become a top notch operator and maintenance person. This you will only become by a lot of hard work and a lot of studying. You must keep up to date on the equipment and the state of the art.

This lesson will give you the start toward an awarding and interesting field of work. But you have to do the rest.

EXERCISE SOLUTIONS

Lesson 1

1. c, (para 1-1)
2. c, (para 1-1g)
3. b, (para 1-1e)
4. a lens, a shutter, a lens board, a cable release (para 1-3)
5. 12 inches, f/6.3 (para 1-3a)
6. five, (T), (B), seven (para 1-3b)
7. 150 watts (para 1-4b)
8. opal glass (para 1-5d)
9. in front of camera lens (para 1-5c)
10. focusing and image size (para 2-1).
11. vertical and horizontal handle grips (para 2-1)
12. Use the back focusing handle. (para 2-1)
13. "M", medium peak flash, X, electronic flash (para 2-2)
14. "T" (para 2-2)
15. Controls the amount of light reaching the film. (para 2-2)
16. MAIN POWER switch is ON. (para 2-3)
17. c, (para 2-3)
18. d, (para 2-3)
19. a, (para 2-3)
20. b, (para 2-4)

21. Set MAIN POWER switch on OFF. (para 2-5a)
22. c, (para 2-5a)
23. 3 1/4" x 4", 4" x 5", 5" x 7", 8" x 10", 11" x 14" (para 2-6a)
24. Standard size rigid copy, nonstandard size or nonrigid copy, negative or colored transparency. (para 2-6)
25. c, (para 3-2c)
26. b, (para 3-2e and f)
27. b, (para 3-3b)
28. d, (para 3-3b)
29. CES = f.22 at 8 seconds. (para 3-3b)
30. c, (para 4-3)
31.
 - a. Preventive maintenance.
 - b. Visual inspection.
 - c. Troubleshooting. (para 4-2)
32. Remove back, close shutter, extend bellows fully, check outside while handlight is inside bellows. (para 4-5)
33. underexposure; make a new negative with more exposure. (para 4-7)
34. Hotspots on negative. Reposition the lights and check for reflections from the front of lens. (para 4-7)
35. d, (para 5-5a)
36. Facilitates leveling camera component (para 5-5a)
37. Tilt lock knob. (figure 6, para 5-5)
38. c, focus button (para 5-5c)
39. Speed scale (para 5-5c)

40. The dull side up and identification notches in the upper right-hand corner. (para 5-6)
41. Paper safety cover facing the dark slide (down). (para 5-6)
42. Spirit level vial (para 5-7)
43. Lens board retainer (para 5-8)
44. d, focus button (para 5-9)
45. Raise the lens board mounting plate. (para 5-10a)
46. Loosen camera mount lock, turn the camera mount adjust knob. (para 5-10b)
47. Use the swings and tilts of the front frame. (para 5-10c)
48. Rotate the revolving back from vertical to the horizontal position. (para 5-10f)
49. d, speed selector ring (para 5-11b)
50. To prevent possible shift of camera position or adjustment. (para 5-12c)
51. a, shooting technique (para 6-1a)
52. c, (para 6-2a)
53. nomenclature and model number (para 6-2b)
54. d, (para 6-3)
55. a camel's hair brush, air syringe or a gentle blast of moisture-free compressed air (para 6-6a)
56. Use a circular motion, start from the edge and work toward the center. (para 6-6a)
57. b, (para 7-2b)
58. daily and monthly (para 7-2c)
59. c, (Table 7-2.2)
60. c, (Table 7-2.7)
61. b, (para 8-1i)

LESSON 2

PHOTOGRAPHIC PRINTING EQUIPMENT

SCOPE:

In this lesson we will talk about the photographic equipment used to produce the image on photographic paper. This will include the Contact Printer, Enlarger and the Ektamatic Paper Processor. Each equipment will be covered in the same order as listed. Also in this lesson, we will ONLY cover the operation and operator's maintenance of each piece of equipment.

SECTION 1

PHOTOGRAPHIC CONTACT PRINTER EN-12(1)

2-1 Controls and Operation (figure 2-1)

a. All controls are mounted on the printer and are divided into two types: the switches (electrical) and the manual controls.

b. The chart below lists these controls, gives location on the printer, and explains their function.

Control	Location	Function
Power switch (ON-OFF)	Lower right side of lamp house, toward rear.	When this switch is plac- ed in the ON position, the ruby safe lamp will light and power is sup- plied to the printer. The four white printing lamps will not light at this time.
MOMENTARY switch	Top center of lamp house, above front panel.	This switch is actuated by the contact spring on the platen arm. When the platen arm is lowered, the switch is closed and the four white printing lamps will light.

Control	Location	Function
Platen arm	Attached to rear of printing head.	This arm is used to raise and lower the platens and to actuate the MOMENTARY switch.
Masking blade	Mounted on guide bars on printing head.	Permits setting of margins to desired print size.

2-2 Preoperational Cleaning Procedures

To clean the equipment before operation, proceed as follows:

a. With a soft camel's hair brush, remove dust from the printing glass, masking blades, and upper surfaces of the printer. Be sure that NO lint or brush hairs cling to the printing glass.

b. Remove fingerprints from the printing glass by using soap and water, and dry with a lint-free cloth.

c. Remove dust or dirt from the diffusion glass. If necessary, remove the printing and diffusion glasses (figure 2-2) and wash them with soap and water. After washing, dry them carefully and replace them in their original position.

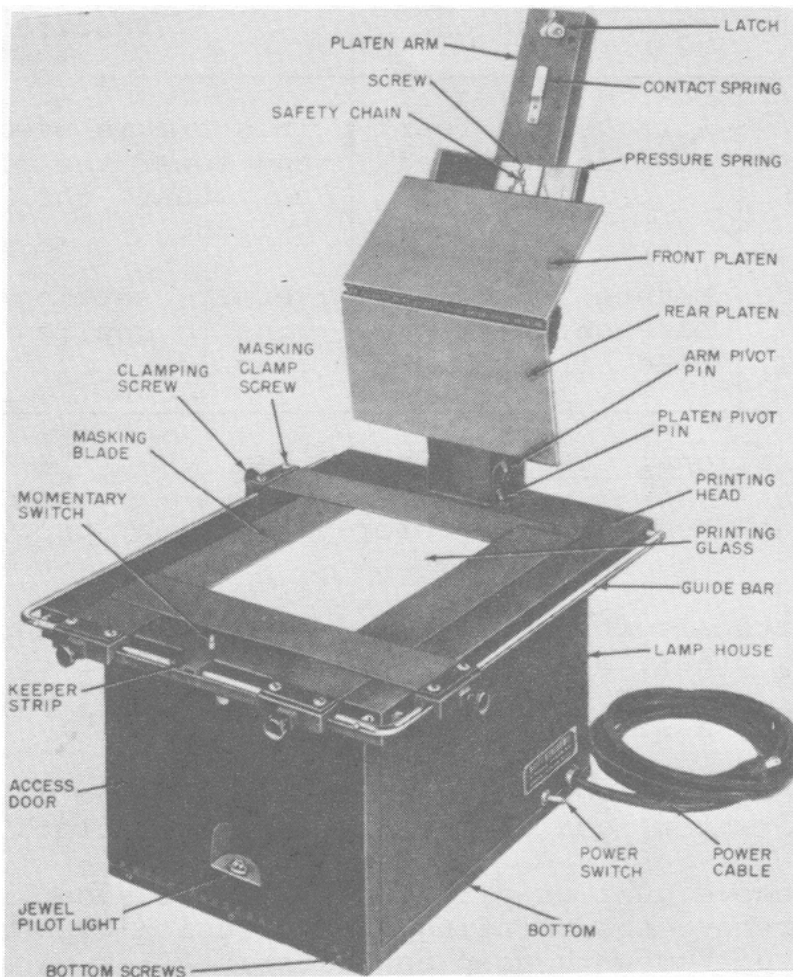

FIGURE 2-1. Photographic Contact Printer EN-12(1), front view.

2-3 Preliminary Starting Procedures (figure 2-1)

Before operating the equipment, check the equipment as follows:

- a. Be sure that the power switch is in the OFF position and that each socket contains the proper lamp (figure 2-2).
- b. See that the masking blades (figure 2-1) are clean and square and that they ride freely on the guide bar.

c. Be sure that the platen arm moves freely from the up position to the lower clamping position and that the latch is held in place by the keeper strip.

d. Be sure that the power cable connector is plugged into the power source. Move the power switch to the ON position. The ruby safe light should light.

CAUTION: See that no unexposed photographic paper is present when the printing lamps are lighted. The lights from the printing lamps will fog the photographic paper.

e. With the access door open (figure 2-2), pull the platen arm down to the closed position, allowing the latch on the platen arm to engage the keeper strip. If all the lamps light, release the latch and allow the platen arm to return to the vertical position. Close the access door.

f. Be sure that the ground side of the diffusion glass faces the printer lamps.

EXERCISE

1. The following statement describes the function of which part of the Contact Printer EN-12(1).

"This switch is actuated by the contact spring on the platen arm. When the platen arm is lowered, the switch is closed and the four white printing lamps will light."

- a. Power switch (ON-OFF).
- b. Platen arm.
- c. MOMENTARY switch.
- d. None of the above.

2. Describe the function of the masking blades.

ANS: _____

2-4 Operating Procedures (figure 2-1)

To operate the printer, proceed as follows:

a. Loosen the clamping screws on the masking blades and lift the masking blades to a vertical position.

b. Place the negative to be printed, emulsion side up, on the printing glass.

c. Lower the masking blades. Adjust the masking blades to the desired print size by loosening the clamping screws. Be sure that the edges of the negative are covered. Tighten the clamping screws to hold the masking blades in the desired position.

d. Place the photographic paper, with the emulsion side down, over the negative and center the image on the paper. Use the ruled lines on the masking blades as a guide.

e. The hinged platen arrangement makes it possible to place and hold the paper properly over the negative before lowering the platen arm all the way. Pull down the platen arm, and hold the paper during the first portion of travel so that the rear platen does not push the paper away from the desired position. When the platen arm (figure 2-1) is partly lowered, the rear platen will hold the paper in place. Continue lowering the platen arm until it is latched. As the platen arm is latched, the contact spring under the platen arm automatically depresses the MOMENTARY switch, lighting the printing lamps (figure 2-2). The jewel light glows when the printing lamps are on.

f. Expose the photographic paper by allowing the platen arm to remain locked for the predetermined exposure time. After the exposure time is completed, release the latch, raise the platen arm, and remove the paper. The paper now is exposed and ready for development.

g. Process the paper. See TM 11-401.

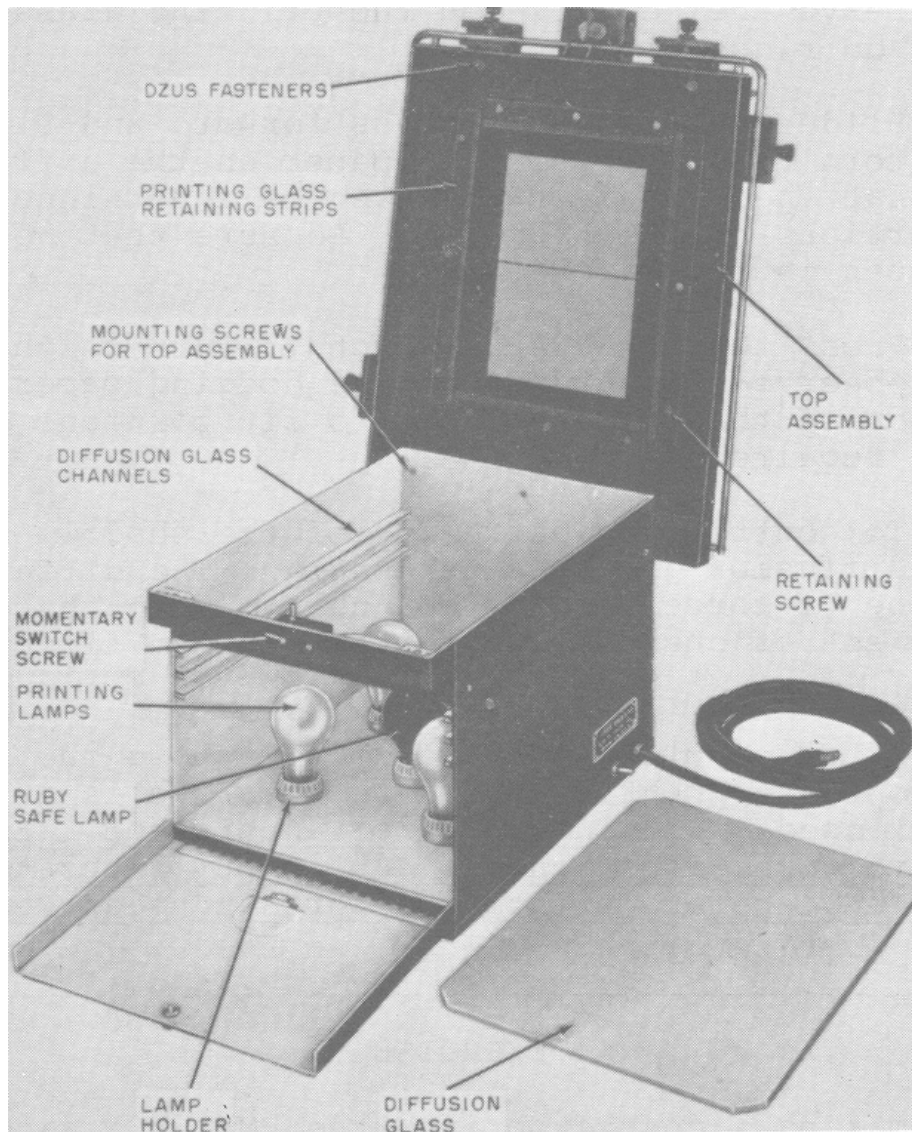

FIGURE 2-2. Photographic Contact Printer EN-12(1), printing head raised, access door open, and diffusion glass removed.

2-5 Dodging

Sometimes it is necessary to print negatives (in certain areas) that are either imperfect or unequal in exposure. Some parts may be considerably denser or lighter than the rest of the negative. The process of balancing the lighting to all of these areas is called dodging. If a test print from a negative indicates that a portion of the print is overexposed, it is necessary to dodge. Dodge ONLY those portions of the negative that show overexposure.

a. Leave the negative on the printing glass and open the access door.

b. Slide the diffusion glass forward and place small pieces of torn tissue or similar paper on the diffusion glass so that their shadows are cast on the thinner or overexposed portions of the negative. Be sure that no unexposed paper is open in the darkroom.

c. Press the MOMENTARY switch to turn on the printing lamps and observe the shadows of the dodging paper. Adjust the position of the dodging paper to fit portions of the negatives as required.

d. To control the diffusion of the shadow, raise or lower the diffusion glass as necessary. The diffusion glass rests on one of three sets of channels. When the glass is on the top set of channels, it gives minimum diffusion of light.

e. After completing the dodging, close the access door and continue printing from the negative as if it were properly exposed. Dodging requires experience. Exposure time also requires experience. Make test prints to acquire this experience before printing important negatives.

EXERCISE

3. When making a contact print, the EMULSION side of both paper and film (negative) must be facing which way?

a. Both down.

c. Paper down, film up.

b. Both up.

d. Film down, paper up.

4. In order to vary the diffusion of the shadow during dodging, you must do what?

ANS: _____

SECTION 2

PREVENTIVE MAINTENANCE SERVICES

2-6 Definition of Preventive Maintenance

Preventive maintenance means making systematic checks and adjustments at regular intervals to keep the equipment operating at top efficiency. It is not the same as troubleshooting or repair. The purpose of troubleshooting and repair is to locate and correct existing defects. Preventive maintenance is designed to prevent the development of defects. The importance of preventive maintenance cannot be overemphasized. Failure or inefficient operation of one piece of equipment may cause the failure of the entire photographic system. It is vitally important, therefore, that operators and repairmen maintain their equipment properly.

2-7 Tools and Materials Used with Equipment

No special tools are necessary for operation of the printer. For organizational maintenance, the following common tools and materials are needed:

Item	Use
Screw driver (1/4" blade)	For slotted screws.
Pliers	For nylon cable grommet and switch retaining nuts.
Stiff bristle brush	Clean dirt and other debris from equipment.
Camel's hair brush	Brush off dust and lint.
Bleached cheesecloth, 36" wide	Wash printing and diffusion glass with soap and water.
Lint-free cloth	Clean dust from lamp house and printing and diffusion glass.
Sandpaper No. 000	Sand rust spots before painting.
Dry cleaning solvent (SD)	Remove dirt and grease from equipment.
Orange stick	Clean dirt from hard-to-reach places.

2-8 Maintenance Instructions

Certain maintenance instructions should be followed for the printer. Cleanliness of the printer is absolutely essential.

a. Clean and dust all parts of the printer after it has been unpacked and before it is put into use.

b. Be sure that no scratches are on the printing glass.

c. Wipe fingerprints from the printing glass with a lint-free cloth. If they do not come off completely, remove the glass and wash with soapy water. Use a clean, lint-free cloth. Dry with a clean towel and brush off any lint with a camel's hair brush.

d. Examine the rubber platen surfaces to be sure that no foreign particles are embedded in them. Remove any foreign particles carefully without cutting the rubber.

e. Inspect all outside surfaces for cracks, chipped paint, broken or cracked glass, bent or dented metal parts, rust, mildew, fungi, loose or missing screws, and accumulations of moisture.

f. Tighten all loose screws and mountings.

g. Inspect all lamps and determine whether replacement is necessary.

h. Inspect all switches and controls for free movement, positive action, and freedom from binding.

NOTE: No lubrication of the equipment is required.

2-9 Preventive Maintenance Checklist

The following chart shows preventive maintenance procedures for the printer. The list contains information on what to check, when to check, how to check, and precautions to be taken before, during, and after checking.

Item No.	What to check	When to check	How to check	Precautions
1	Power cable (figure 2-1)	Weekly	Examine for abrasion, cuts, or breaks. See that connections are tight.	Examine before plugging into power source. Tighten screws snugly, keep cable clean.
2	Printing and ruby lamps (figure 2-2)	Daily before use	See that they are tight in their sockets and that they are all operating. Check all wiring.	If they do not light, replace with new lamps as required.
3	Momentary switch (figure 2-1)	Daily before use	Pull down platen arm until it catches. See whether printing lamps light and go out when arm is released.	Be sure that no sensitized material is open in the darkroom.
4	Printing glass (figure 2-1)	Daily before use	Examine visually for scratches or debris.	If debris cannot be brushed off, try to soak it off. Scratched glass must be replaced.
5	Masking blades (figure 2-1)	Daily before use	Examine for rust, bends, or nicks.	Straighten, remove rust. If badly damaged, replacement if necessary.
6	Rubber platens (figure 2-1)	Daily before use	Examine for foreign particles.	Clean with a moist cloth, but be sure to dry before use.
7	Diffusion glass (figure 2-2)	Daily before use	Examine for left-over dodging material.	Remove old dodging material and clean glass.

Item No.	What to check	When to check	How to check	Precautions
8	Power switch (figure 2-1)	Weekly	Inspect for free movement, dirt, positive action.	Be sure all leads are in good order and properly connected.
9	Lamp house (figure 2-2)	Monthly	Inspect for dirt, cracks, loose or missing screws, loose mounting, defective cable.	Remove dirt. Tighten loose screws; replace missing ones.

EXERCISE

5. What is the purpose of preventive maintenance?

ANS: _____

6. In order to remove hard to clean fingerprints and smudge marks from the printing glass, you should _____

_____ (complete statement)

2-10 Troubleshooting at Organizational Maintenance Level

a. General. Organizational troubleshooting is performed by the operator or unit repairman. Familiarity with the equipment will help in the locating of some troubles and in making minor repairs. Any abnormal performance must be checked, its cause discovered, and repairs made. Repairs beyond the ability of the operator or unit repairman must be referred to higher repair authority. When troubles occur, refer to the equipment performance checklist (para 2-13) and to the general procedures as outlined in paragraph 2-11.

2-11 Visual Inspection (figures 2-1 and 2-2)

Most defects that may occur in the printer may be detected by visual inspection.

a. Examine the power cable to see that the connecting plug and conductors have not been damaged.

b. Connect the equipment to a power source and move the power switch to the ON position; the ruby safe lamp should light automatically.

c. Light the printing lamps by manually pressing down on the MOMENTARY switch. If any of the printing lamps fail to light, try a replacement lamp.

d. Examine the masking blades, platen (front and rear) and platen springs to see that they are not physically damaged.

e. Examine the lamp house and the printing head for obvious physical damage.

2-12 Troubleshooting

a. General. The equipment performance checklist (para 2-13) will help to locate trouble in the equipment. The list gives the items to be checked the normal indication and tolerances of correct operation and the corrective measures that can be taken by the operator. When using this list, follow the items in numerical sequence.

b. Action or condition. For some items, the information given in the action or condition column consists of various switch and control settings at which the item is to be checked. For other items, it represents an action that must be taken to check the normal indication given in the normal indication column.

c. Normal indication. The normal indications listed include the visible and audible signs that the operator should detect when he checks the items. If the indications are not normal, the operator should apply the recommended corrective measures.

d. Corrective measures. The corrective measures listed are those that the operator can make. If the set is completely inoperative and if the recommended corrective measures do not yield results, troubleshooting is necessary. However, if the tactical situation requires that operation be maintained, and if the printer is not completely inoperative, the operator must keep the printer in operation as long as possible.

Item No.	Item	Action or Condition	Normal Indication	Corrective Measures
1	Power cable (figure 2-1)	Plug into power supply		
2	Power switch (figure 2-1)	Snap to ON and OFF (figure 2-1)	Ruby safe lamp lights and goes out.	Check the power source and the power cable. Install a new ruby safe lamp. Turn in equipment for repair.
3	MOMENTARY switch (figure 2-1)	Push plunger down (figure 2-1)	Printing lamps go on.	Replace any defective printing lamps. If no printing lamps light, it may be necessary to adjust position of MOMENTARY switch. Move the switch out by loosening the inside nut and tightening the outside nut.

PREPARATORY

START

EQUIPMENT PERFORMANCE

Item No.	Item	Action or Condition	Normal Indication	Corrective Measures
4	Platen arm (figure 2-1)	Pull platen arm down and lock in position (figure 2-1)	Presses printing paper in absolute contact with negative. Actuates MOMENTARY switch and turns printing lamps on.	Check printer top platen hinge, platen face, and platen spring. Check contact spring and latch.
5	Printing lamps (figure 2-1)	Proper lamps selected and mounted in sockets.	Lamps should light when platen is lowered and latched.	Check contacts on lamp bases. Check lamps.
6	Masking blades (figure 2-1)	Frames print to the desired size.	Masking blades should lock, holding even margin.	Check frame and clamps. Clean. Turn in equipment for repair. If fuzzy print results, examine for defective platen springs. Turn in equipment for repair.

Item No.	Item	Action or Condition	Normal Indication	Corrective Measures
7	Platen arm (figure 2-1)	Platen arm raised.	Releases plunger on MOMENTARY switch and turns off printing lamps.	Check MOMENTARY switch for defect if printing lamps do not go off. Check action of MOMENTARY switch actuating lever. Turn in equipment for repair.
8	Power switch (figure 2-1)	Moved to OFF position.	Ruby safe lamp goes out.	If ruby safe lamp still lights, it indicates a defective power switch. Turn in equipment for repair.
9	Power cable (figure 2-1)	Remove from power source.		

STOP

EXERCISE

7. Who performs the organizational troubleshooting on a piece of equipment?

ANS: _____

8. After the equipment is connected to a power source and the power switch is set to ON, how do you know if there is power to the equipment?

ANS: _____

9. What are the four step sequence of the Equipment Performance Checklist?

ANS: _____, _____,

_____, _____.

2-14 Maintenance Forms

For the use of maintenance forms, check TM 38-750 w/c 2.

SECTION 3

PRINTER, PROJECTION, PHOTOGRAPHIC EN-91A AND EN-18B

2-15 Scope

a. This section will cover the Printer, Projection, Photographic EN-91A and EN-18A to include the operating instructions and operator's maintenance. It includes operation under usual conditions, cleaning and inspection of the equipment and replacement of parts available to the operator.

b. Throughout this section, Printer, Projection, Photographic EN-91A or EN-18B is referred to as printer. Easel, Projection, Printing FN-9(1) or FN-10(1) is referred to as easel.

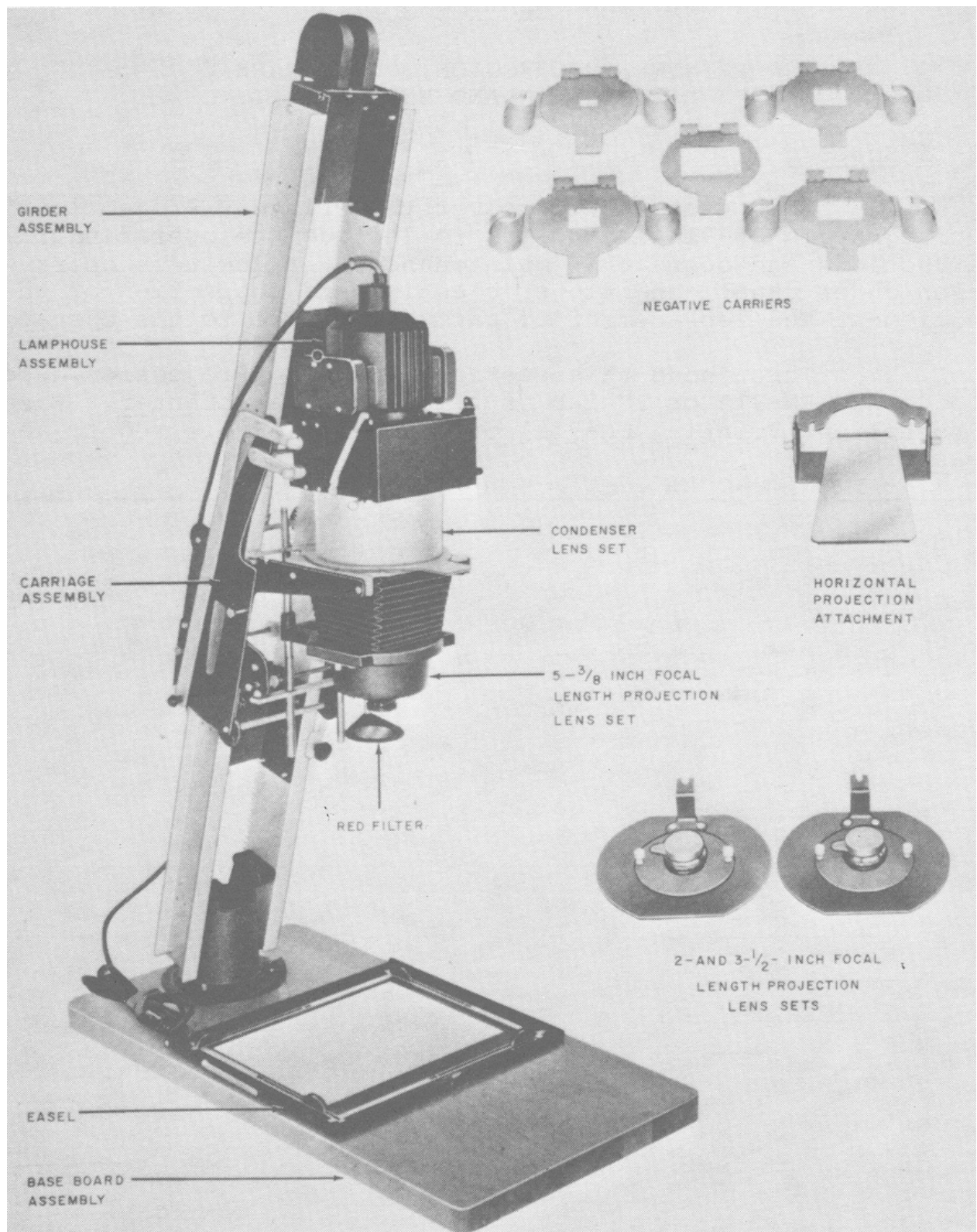

FIGURE 2-3. Printer, Projection, Photographic EN-91A.

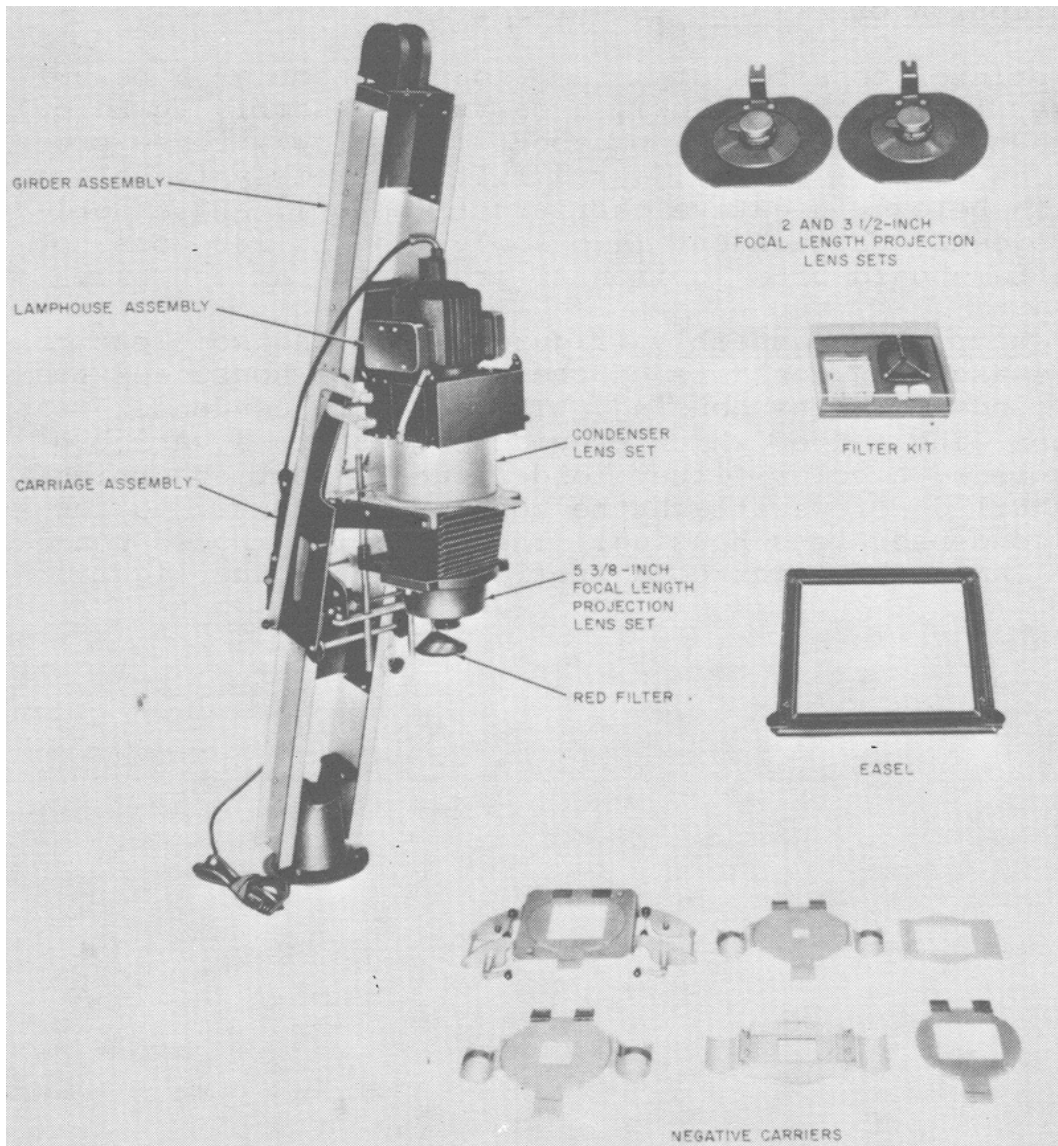

FIGURE 2-4. Printer, Projection, Photographic EN-18B.

2-16 Description of Printer (figures 2-3 and 2-4)

The printer consists of a lamp house assembly (a below), a condenser lens set (b below), a carriage assembly (c below), girder assembly (d below), a baseboard (e below), three projection lens sets (f below), a red filter assembly (g below), an easel (h below), negative carriers (i below), and a horizontal projection attachment (j below). The EN-18B does not include a baseboard or a horizontal projection attachment.

a. Lamp house assembly (figure 2-5). The complete lamp house assembly consists of the upper lamp house and the variable condenser lens housing. The variable condenser lens housing contains a door which provides access to a variable condenser lens, a color filter holder, and a heat absorbing glass. Knurled screws attach the condenser lens set to the variable condenser lens housing. The upper lamp house contains the lamp, the light cone (reflector), and the light traps.

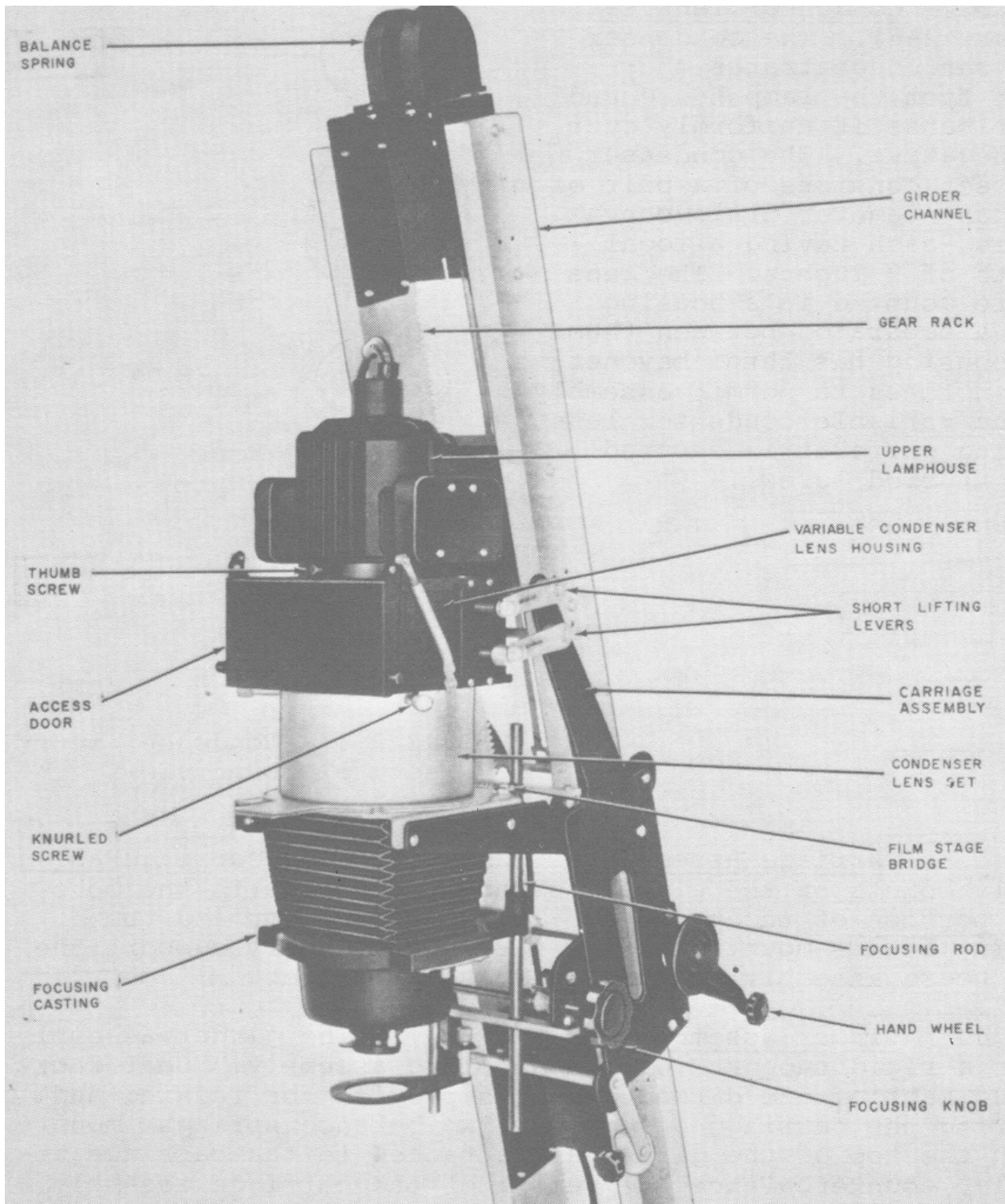

FIGURE 2-5. Printer, right-side view.

b. Condenser lens set (figure 2-6). The condenser lens set concentrates the light from the lamp house and distributes it uniformly over the negative. The condenser lens set consists of a pair of 6 1/2-inch diameter plano-convex lenses, each having a focal length of 9 inches. The lenses are mounted in a housing with a separator between them. The housing has three bayonet-type notches to permit assembly to the variable condenser lens housing where it is secured with knurled screws.

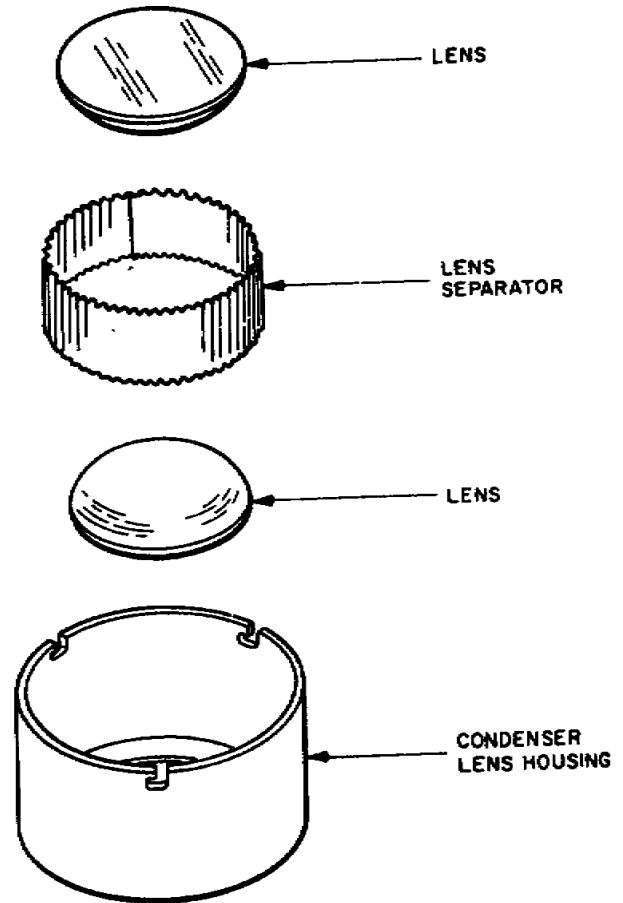

FIGURE 2-6. Condenser lens set, exploded view.

c. Carriage assembly (figure 2-5). The carriage assembly mounts on the girder assembly and supports the movable portion of the printer. The control lever and the lifting levers mounted on the carriage assembly support the lamp house assembly and the condenser lens set.

d. Girder assembly (figure 2-5). The girder assembly forms a rigid support for the carriage assembly. Gear racks at the back of the girder channels provide for raising and lowering the carriage assembly. Two balance springs, mounted on the top of the girder and attached to the carriage assembly, counterbalance the weight of the carriage assembly.

e. Baseboard assembly, EN-91A (figure 2-7). The baseboard assembly consists of a wooden baseboard and a steel baseboard plate that forms the mounting support for the girder assembly. Three rotary clamping pads secure the girder assembly to the baseboard.

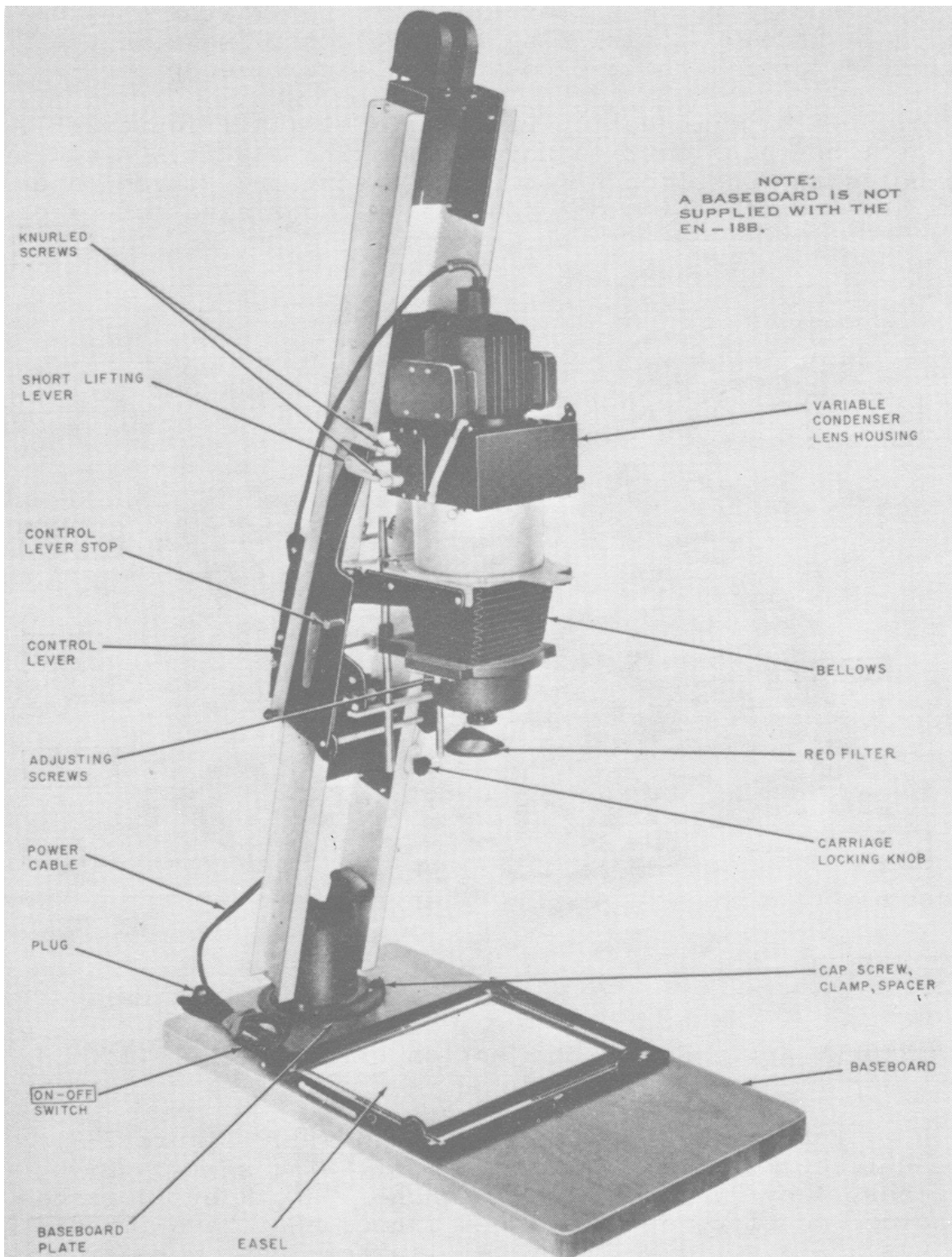

FIGURE 2-7. Printer, left-side view.

f. Red filter (figure 2-7). The red filter is provided for visually positioning the projected image on the sensitized paper without exposing the sensitized paper.

g. Easel, Projection Printing FN-10(1) (figure 2-8). The easel contains four adjustable masking blades. A click stop holds the easel open for paper insertion. Three paper slots are incorporated to accommodate various sizes of paper.

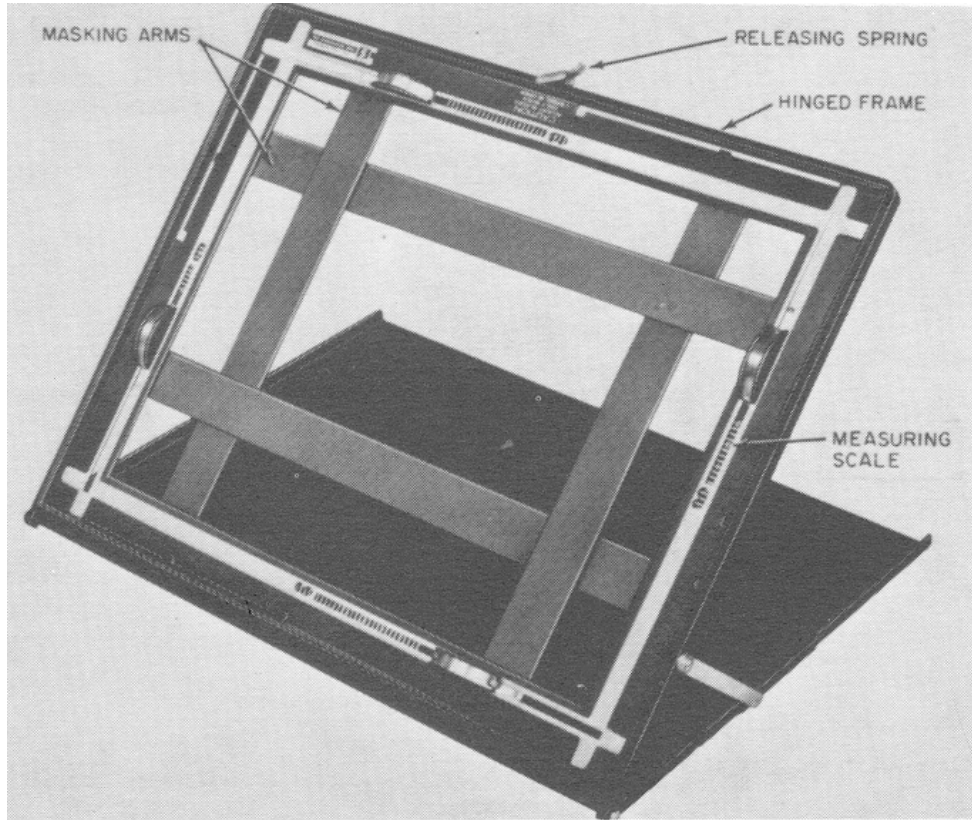

FIGURE 2-8. Easel, Projection Printing FN-10(1).

h. Easel, Projection Printing FN-9(1) (figure 2-9). The easel accommodates paper of the following sizes: 2 1/2 by 3 1/2 inches, 4 by 5 inches, 5 by 7 inches, and 8 by 10 inches. The holder consists of two hinged frames that have fixed openings and a solid white enamel finished center section.

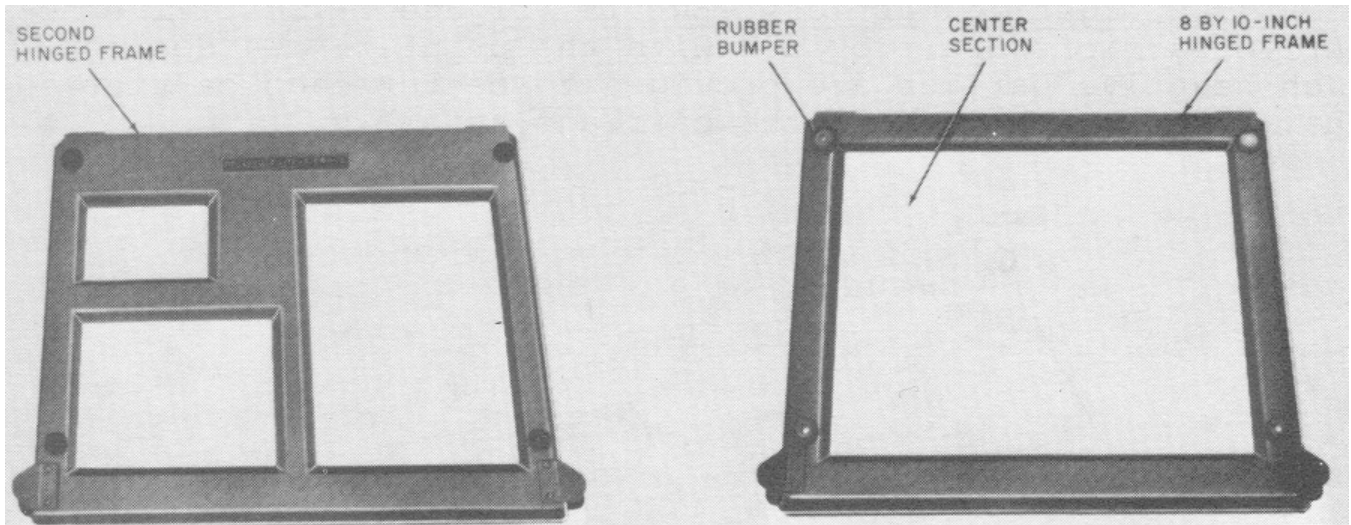

FIGURE 2-9. Easel, Projection Printing FN-9(1).

i. Projection lens sets (figure 2-10). Three projection lens sets, having focal lengths of 2, 3 1/2, and 5 3/8 inches, are supplied with the printer. Each lens board has been cut off at two diametrically opposed sides of the top to permit bayonet-type mounting, and each is equipped with a bracket on which the red filter assembly can be mounted by a knurled screw.

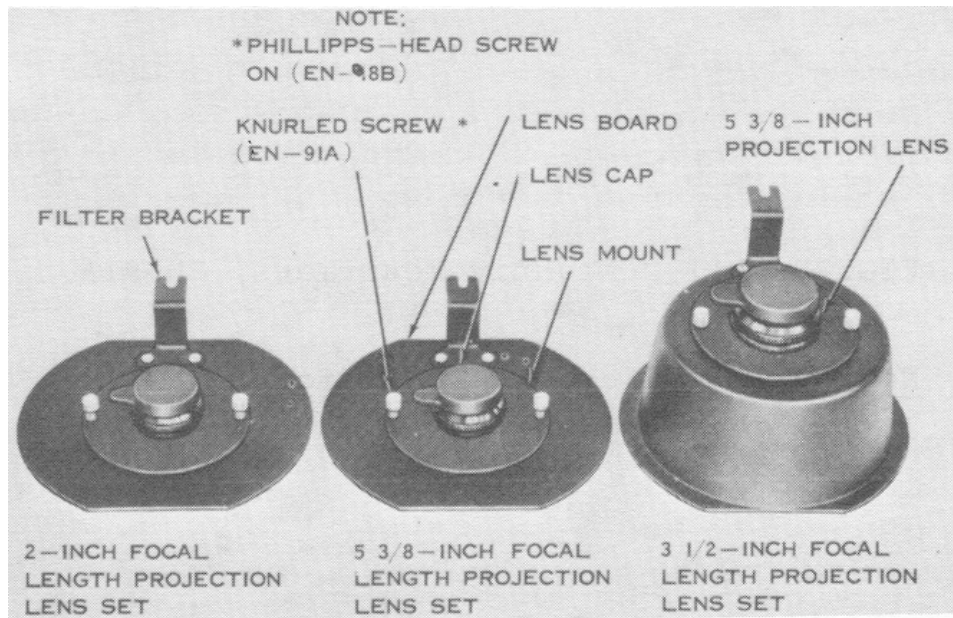

FIGURE 2-10. Projection lens sets.

j. Negative Carriers, EN-91A (figure 2-11). Five negative carriers are provided with the printer. Guides in each negative carrier are provided to center each carrier in the film stage bridge of the carriage assembly.

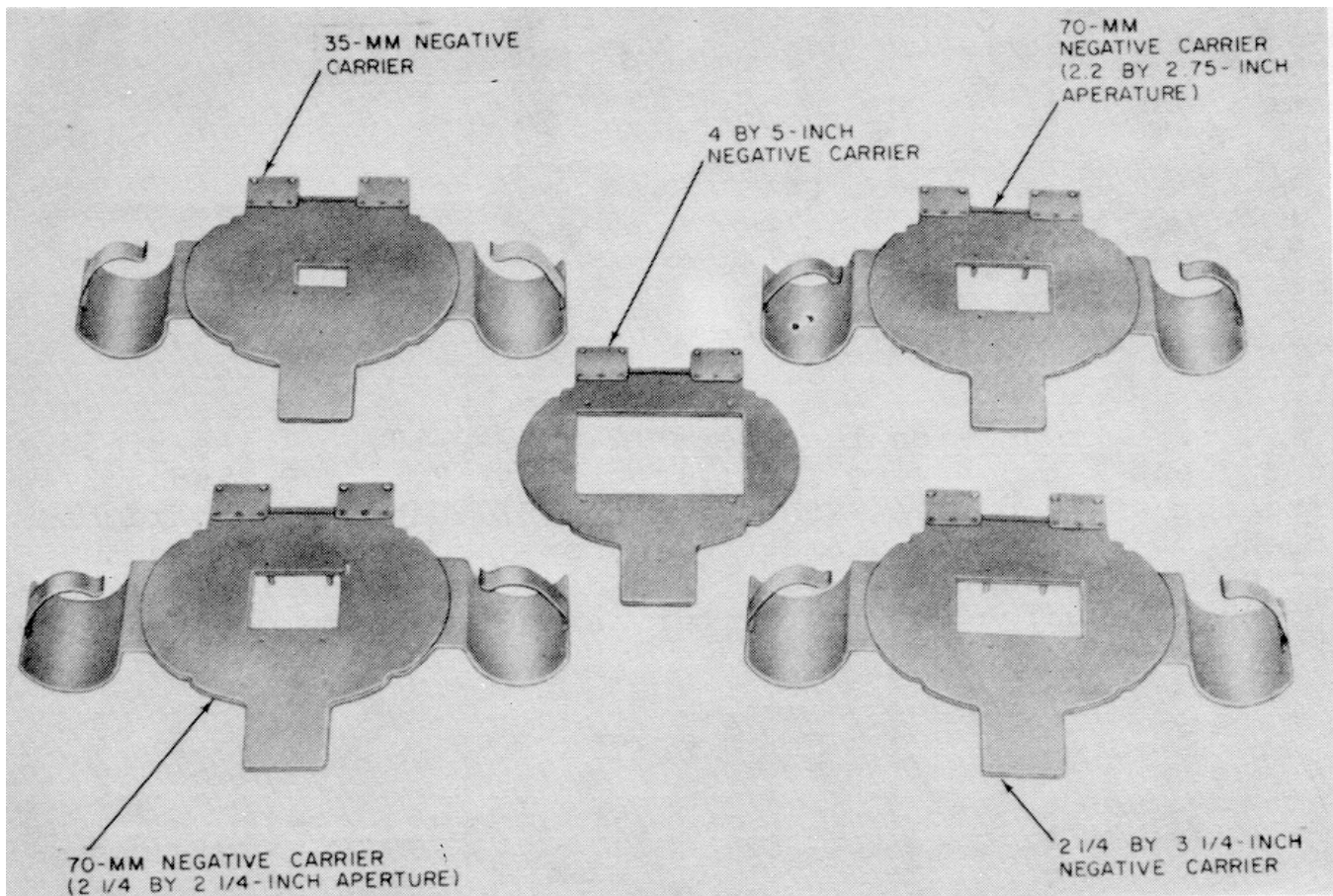

FIGURE 2-11. Negative carriers, EN-91A.

k. Negative Carrier, EN-18B (figure 2-12). Six negative carriers are provided with the printer. Guides in each negative carrier center the carrier in the printer.

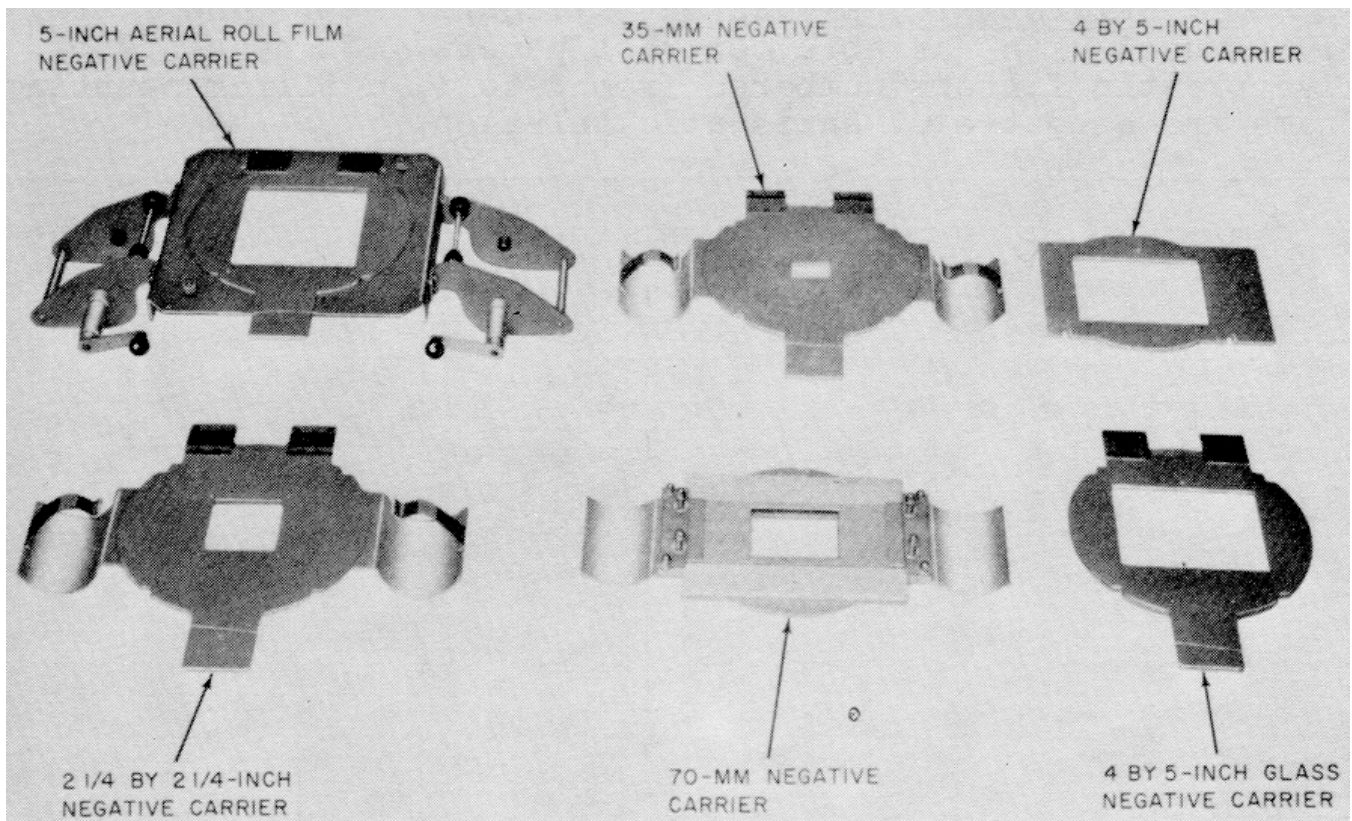
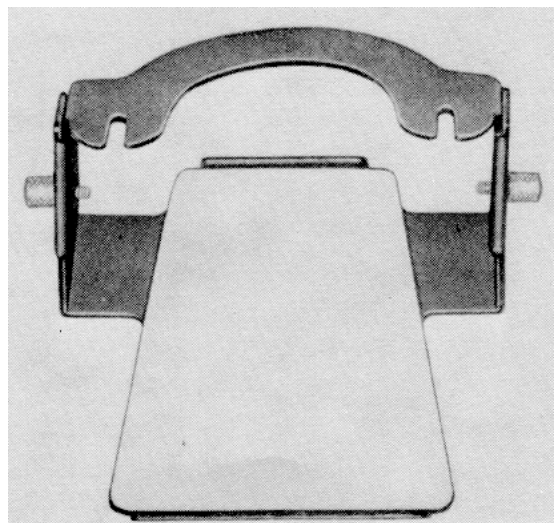

FIGURE 2-12. Negative carriers, EN-18B.

1. Horizontal Projection Attachment, EN-91A only (figure 2-13). The horizontal projection attachment provides for making large size prints. The image is projected on the wall by the 45 degree ground surface coated mirror.



projection

FIGURE 2-13. Horizontal attachment, FN-91A only.

m. Filter Kit, EN-18B only (figure 2-4). The filter kit is used with variable contrast papers. It consists of five plastic filters numbered from 0 to 4, a filter mounting frame and a bottle of antistatic solution.

SECTION 4

OPERATION INSTRUCTIONS

2-17 Controls (figure 2-14)

Control	Function
Carriage locking knob	Locks carriage assembly in position on girder assembly.
Control lever	Forward position: raises lamp house assembly. Rear position: lowers lamp house assembly.
Control lever stop	Locks control lever in forward (raise) position.
Diaphragm ring	Sets lens opening between f/4.5 and f/32.
Focusing wheel	Varies distance of projection lens from film to control focus.
Handwheel	Varies distance of carriage assembly from sensitized paper to control size of enlargement.
ON-OFF switch (figure 2-3)	ON position: applies power to printer. OFF position: removes power from printer.

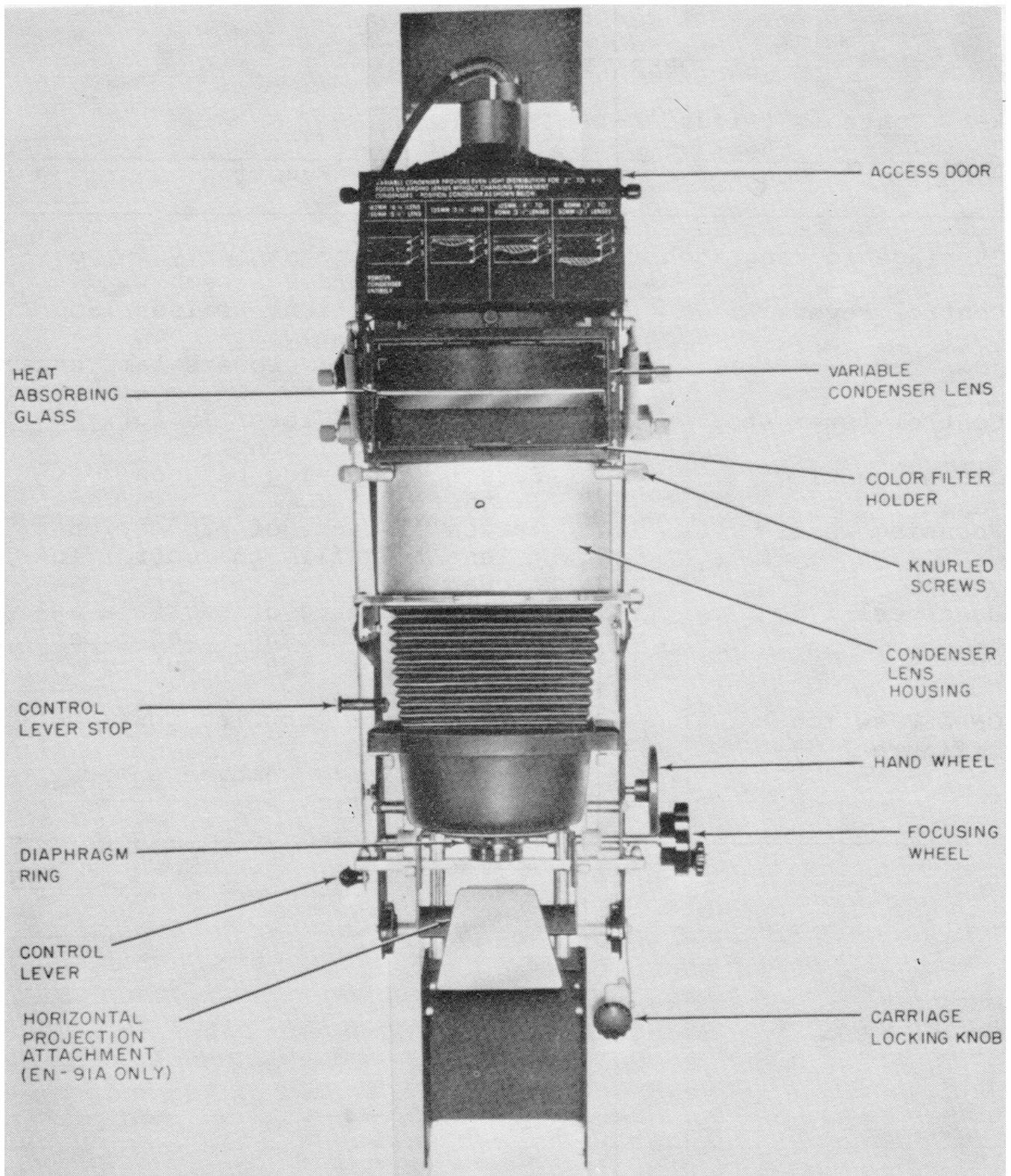

FIGURE 2-14. Operator's controls.

2-18 Selecting Projection Lens Set and Determining Variable Condenser Lens Position

Use the chart (a below) to select the projection lens set and to determine the variable condenser lens position; if necessary, change the projection lens set (b below) and the variable condenser lens position (c below).

a. Chart.

Negative size	Projection lens set	Variable condenser lens position
4 by 5 inch	5 3/8 inch	1
2 1/4 by 2 1/4 or 2 1/4 by 3 1/4 inch	3 1/2 inch	2
35mm	2 inch	3

b. Changing projection lens sets.

(1) Removal. Rotate the projection lens set approximately one-quarter turn until it is disengaged, and remove it from the printer.

NOTE: If the projection lens set does not turn easily, slightly loosen the adjusting screw (figure 2-3).

(2) Replacement. Hold the replacement projection lens set so that its straight sides are parallel to the long sides of the baseboard; insert the projection lens set in the printer and rotate it approximately one-quarter turn to lock it in position.

c. Changing variable condenser lens position.

(1) Open the access door.

(2) Slide out the variable condenser lens.

(3) Slide the variable condenser lens into the correct position (a above).

(4) Close the access door.

2-19 Using Negative Carriers

a. Roll film.

(1) Hold the carrier so that the curves of the negative carrier face upward and place the roll of film in the left-hand curve.

(2) Pass the film, emulsion side down, between the upper and lower plates of the carrier until the frame to be enlarged is centered in the aperture.

(3) Press the upper plate against the lower plate. Pull the control lever forward and place the negative carrier on the film stage bridge; return the control lever to the rear position.

b. 4 by 5 inch negative carrier.

(1) Place the film, emulsion side down, over the lower plate of the carrier.

(2) Proceed as indicated in a(3) above.

c. 5-inch aerial roll film negative carrier.

(1) Place the spool of film on the handcrank shaft in one of the bracket assemblies and place an empty film spool on the corresponding shaft in the other bracket assembly. To place a film spool on the shaft, push the shaft in against the pivot until one end is free. Slip the spool over the free end of the shaft.

(2) Slide the film, emulsion side down, between the negative carrier plates, and insert the free end of the film strip in the empty spool.

(3) Turn the handcrank which controls the empty spool until the frame to be enlarged is centered in the aperture.

2-20 Using Easel, Projection Printing FN-10(1) (figure 2-8)

a. Pull out the releasing spring and raise the hinged frame.

b. Adjust the masking arms for the size enlargement to be made.

- c. Place a piece of waste enlarging paper against the guide on the base of the easel to provide a white reflecting surface for focusing (para 2-22).
- d. Lower the hinged frame and lock it in place with the releasing spring.

2-21 Using Easel, Projection Printing FN-9(1) (figure 2-9)

- a. Place the easel on a table, with the side having the desired paper aperture facing up.
- b. Raise the hinged frame.
- c. Place a sheet of enlarging paper on the base with upper left-hand portion of the paper against the paper guide.
- d. Lower the hinged frame.

2-22 Image Size and Focus (figure 2-14)

- a. Be sure that the correct projection lens set is in place and the variable condenser lens is in the correct position (para 2-18).
- b. Connect the equipment to the source of power.
- c. If the printer is not being used for color, be sure that the color filter has been removed. If the printer is being used for color, proceed as indicated in paragraph 2-25, then perform the procedures given in d through m below.
- d. Remove the lens cap from the projection lens and turn the diaphragm ring clockwise to the largest aperture (f/4.5).
- e. Load a negative corner (para 2-19) and position it on the film stage bridge.
- f. Turn the room lights OFF and the safelight ON.
- g. Place the printer ON-OFF switch to ON.
- h. Loosen the carriage locking knob (figure 2-14).
- i. Using the handwheel, raise or lower the carriage assembly until the desired size of the projected image is obtained.

j. Tighten the carriage locking knob.

k. Turn the focusing wheel until the projected image is in sharp focus.

NOTE: It may be necessary to alternately adjust the carriage assembly position and the focus several times before the desired projected image size and focus are obtained.

l. Adjust the f/stop opening of the projection lens by turning the diaphragm ring until the desired illumination of the projected image is obtained.

m. Turn the ON-OFF switch to OFF.

2-23 Making Prints

a. Obtain correct image size and focus (para 2-22).

b. Remove the waste enlarging paper (para 2-20) and replace it with a sheet of good enlarging paper.

c. Place the ON-OFF switch to ON to make the exposure. The required exposure time depends on the brightness of the projected image and the speed (sensitivity) of the enlarging paper used.

d. Snap the ON-OFF switch to OFF after the exposure is completed.

e. Remove the exposed enlarging paper from the easel and slide it into the developer. Develop, fix, wash, and dry the print (TM 11-401-1).

f. If cut film is being used, raise the lamp house assembly by moving the control lever forward and remove the negative carrier. Remove the negative and replace with the next negative to be printed in the negative carrier; replace the negative carrier in the printer.

g. If roll film is being used, raise the lamp house assembly to prevent scratching the film, and move the film to the next frame to be printed.

h. Repeat the procedures given in a through g above for each negative to be printed.

EXERCISE

10. Why should you open the largest aperture (f/4.5) when getting ready to frame and focus an image?

ANS: _____

11. In order to obtain the desired image size on the easel during focusing, you must do the following:

ANS: _____

2-24 Horizontal Projection

If the degree of enlargement desired is greater than can be obtained using vertical projection, the horizontal projection attachment (figure 2-13) may be used. Install the horizontal projection attachment as follows:

- a. Remove the projection lens set from the printer.
- b. Loosen the knurled screws on the projection lens set.
- c. Position the two slots of the horizontal projection attachment under the heads of the knurled screws.
- d. Tighten the knurled screws.
- e. Replace the projection lens set back under the carriage assembly.
- f. Remove the dust cover from the mirror.

NOTE: Insert the negative to be enlarged in the negative carrier with the emulsion side up. This will compensate for the mirror reversal and the projected image will be corrected left to right.

- g. Place the printer ON-OFF switch to ON.
- h. Focus the image on the wall, raising or lowering the carriage assembly to bring the image into the desired area.

i. Move the printer closer to the wall or farther from the wall to make the projected image smaller or larger, respectively. Refocus each time the distance is changed. Make sure the printer faces the wall squarely to prevent image distortion.

j. Place the printer ON-OFF switch to OFF.

k. Fasten the enlarging paper to the wall in position to receive the desired portion of the image.

l. Perform the procedures outlined in paragraphs 2-23c through g for each negative to be printed horizontally, then proceed as follows:

(1) Place the dust cover on the mirror of the attachment.

(2) Remove the projection lens set.

(3) Loosen the knurled screws securing the horizontal projection attachment and lens mount to the lens board, and remove the detachment.

2-25 Color Printing

The color filter controls the color of the printing light when making color prints. To prevent damage to the color filter, remove it when using the printer for work other than color printing. To place a color filter in the color filter holder, proceed as follows:

a. Lift the top half from the bottom of the holder.

b. Place the color filter on the bottom of the holder.

c. Position the top half on the bottom half of the holder so that the locating pins are engaged.

NOTE: For more detailed information on or about color printing, complete Subcourse SS0515, Color Photograph II.

d. Place the color filter holder in position 3 in the variable condenser lens housing (figure 2-14).

NOTE: If the variable condenser lens is in position 3, place the color filter holder on top of the variable condenser lens.

e. Place the heat absorbing glass in position 2.

NOTE: If the variable condenser lens is in position 2, place the heat absorbing glass on top of the variable condenser lens.

EXERCISE

12. Where must you install the horizontal projection attachment on the printer when you want to make an extra-large enlargement with the EN-91A?

ANS: _____

13. Which way must the emulsion side face in the negative carrier when you are using the horizontal projection attachment?

ANS: _____

SECTION 4

OPERATOR'S MAINTENANCE INSTRUCTIONS

2-26 Scope of Operator's Maintenance

The maintenance duties assigned to the operator of the printer are listed below together with a reference to the paragraphs covering the specific maintenance function. The duties assigned do not require tools or test equipment. The materials required are listed in paragraph 2-27.

- a. Daily preventive maintenance checks and services (para 2-30).
- b. Weekly preventive maintenance checks and services (para 2-31).
- c. Cleaning (para 2-32).
- d. Troubleshooting (para 2-33).
- e. Repairs (para 2-34).
- f. Adjustments (para 2-35).

2-27 Operator's Material Required

- a. Cleaning compound (FSN 7930-395-9542).
- b. Lens cleaner (FSN 6750-408-5175).
- c. Lens tissue (FSN 6640-393-2093).
- d. Textile cloth (FSN 8305-267-3015).

2-28 Operator's Preventive Maintenance

Preventive maintenance is the systematic care, servicing, and inspection of equipment to prevent the occurrence of trouble, to reduce downtime, and to assure that the equipment is serviceable.

a. Systematic care. The procedures given in paragraphs 2-30, 2-31, and 2-33 cover routine systematic care and cleaning essential to proper upkeep of the equipment.

b. Preventive maintenance checks and services. The preventive maintenance checks and services charts (para 2-30

and 2-31) outline functions to be performed at specific intervals. These checks and services are to maintain any photographic equipment in a combat serviceable condition; that is, in good general (physical) condition and in good operating condition. To assist operators in maintaining combat serviceability, the charts indicate what to check, how to check, and the normal conditions; the references column lists the paragraphs that contain detailed cleaning, repair, or replacement procedures. If the defect cannot be remedied by the operator, higher category maintenance or repair is required. Records and reports of these checks and services must be made in accordance with the requirement set forth in TM 38-750 w/c 2.

2-29 Operator's Preventive Maintenance Checks and Service Periods

Operator's preventive maintenance checks and services on the printer are required daily and weekly. Paragraphs 2-30 and 2-31 specify the items to be checked and serviced. In addition to the routine daily checks and services, the equipment should be rechecked and serviced immediately before going on a mission and as soon after completion of the mission as possible.

2-30 Operator's Preventive Maintenance Checks and Service Chart

a. Physical checks.

Sequence No.	Item to be inspected	Procedure	References
1	Exterior surfaces	Clean exterior surfaces of printer.	Para 2-32
2	Lenses	Check condenser lenses and projection lenses for dust, dirt, scratches, or cracks. Clean dirty lenses.	Para 2-32
3	Heater absorbing glass	Check for dust dirt, scratches, or cracks. Clean dirty glass.	Para 2-32

Sequence No.	Item to be inspected	Procedure	References
4	Horizontal projection attachments	Check mirror for dust, dirt, scratches, or cracks. Clean dirty mirror surface.	Para 2-32
5	Condenser lens set	Check for secure engagement with knurled screws. Tighten loose knurled screws.	Para 2-34
6	Variable condenser lens housing	See that the thumb-screw securing the variable condenser lens housing to upper lamphouse is tight.	Figure 2-5

b. Operational check.

Sequence No.	Item to be inspected	Procedure	References
7	ON-OFF switch	Place in ON position. Printer lamp should light and project light on easel.	Para 2-34
8	Negative carrier	Position loaded negative carrier on film stage bridge.	
9	Easel	Load easel with plain white paper.	
10	Handwheel	Raise or lower carriage assembly as required for correct enlargement size. a. Motion should be free.	

Sequence No.	Item to be inspected	Procedure	References
11	Focusing knob	<ul style="list-style-type: none"> b. Image should be free of spots, streaks, or lines. c. Image should be of desired enlargement size (para 2-22). Adjust for sharp focus (para 2-22). <ul style="list-style-type: none"> a. Image should be in sharp focus. b. Check for light streaks from bellows. 	
12	Diaphragm ring	Adjust f/stop opening. Image should darken and remain evenly illuminated (para 2-22).	

2-31 Operator's Weekly Preventive Maintenance Checks and Service Chart

Sequence No.	Item to be inspected	Procedure	References
1	Power cable	Check power cable for cut or frayed insulation, or defective ON-OFF switch, plug, or lampholder.	
2	Mounting	Tighten all knurled screws. Replace missing hardware as required.	

Sequence No.	Item to be inspected	Procedure	References
3	Minor components	Check minor components for dirt and breakage. Clean dirt components.	para 2-32
4	Carrying case	Check carrying case for wear or breakage. Clean carrying case.	para 2-32

EXERCISE

14. What is the only material required by the operator when performing operator's preventive maintenance on the printer?

ANS: _____

15. All maintenance records and reports must be completed in accordance with _____.

(fill in)

16. What are the various types of checks to be performed by the operator?

ANS: _____

2-32 Operator's Cleaning

Inspect the exteriors of the printer, the negative carriers. The exterior surfaces should be free from dust, dirt, grease, and fungus.

a. Remove dust and loose dirt with a clean soft cloth.

WARNING: CLEANING COMPOUND IS FLAMMABLE AND ITS FUMES ARE TOXIC. PROVIDE ADEQUATE VENTILATION. DO NOT USE NEAR A FLAME.

b. Remove grease, fungus, and ground-in dirt from the case; use a cloth dampened (not wet) with cleaning compound.

c. Clean each lens with tissue. If necessary, dampen the lens tissue with lens cleaner; after cleaning, wipe the lens dry with clean lens tissue.

d. Clean the mirror of the horizontal projection attachment (figure 2-13) with lens tissue dampened with water.

2-33 Operator's Troubleshooting Chart

Item No.	Trouble symptom	Probable trouble	Check and corrective measures
1	Light is not projected on easel when ON-OFF switch is placed to ON.	Lens cap not removed from projection lens. Loose or defective printer lamp. Defective ON-OFF switch Defective lamp-holder Defective plug Defective power cable	Remove lens cap. Check lamp installation or replace defective lamp (para 2-34). Higher category maintenance required. Higher category maintenance required. Higher category maintenance required. Higher category maintenance required.
1	a. Carriage assembly does not move freely. b. Image contains spots, streaks, or lines.	Carriage locking knob not loosened. Nylon tip in locking knob excessively worn or damaged. Printer out of alignment Negative contains foreign matter or scratches.	Loosen carriage locking knob. Replace locking knob. Higher category maintenance required. Use negative that is in good condition.

Item No.	Trouble symptom	Probable trouble	Check and corrective measures
	c. Desired image size cannot be obtained.	Unclean condenser lenses Scratched or damaged condenser lenses Improper combination of variable condenser lens positioning and projection lens set selection.	Clean condenser lenses (para 2-32). Replace damaged condenser lenses (para 2-34). See that proper projection lens set is used for negative being enlarged and that variable condenser lens is properly positioned (para 2-18).
3	a. Projected image not evenly illuminated.	a. Variable condenser lens not properly positioned. b. Wrong projection lens set being used.	a. Use proper projection lens set for negative being enlarged (para 2-19). b. Check variable condenser lens position (para 2-18).
4	Image not sharp and clear	a. Printer improperly focused. b. Projection lens dirty c. Defective projection lens	a. Check focus. b. Clean lens (para 2-32). c. Higher category maintenance required.

2-34 Operator's Repairs

a. Printer, lamp, replacement (figure 2-15).

(1) Loosen the thumbscrews (5).

(2) Remove the upper lamp house (2).

(3) Reach inside the upper lamp house (2) and unscrew the printer lamp (1).

(4) Check the condition of the light cone (reflector) inside the upper lamp house (2). Remove dust or dirt with a clean, lint-free cloth.

(5) Replace the printer lamp (1), and position the upper lamp house on the variable condenser lens housing (4).

(6) Tighten the thumbscrew (5).

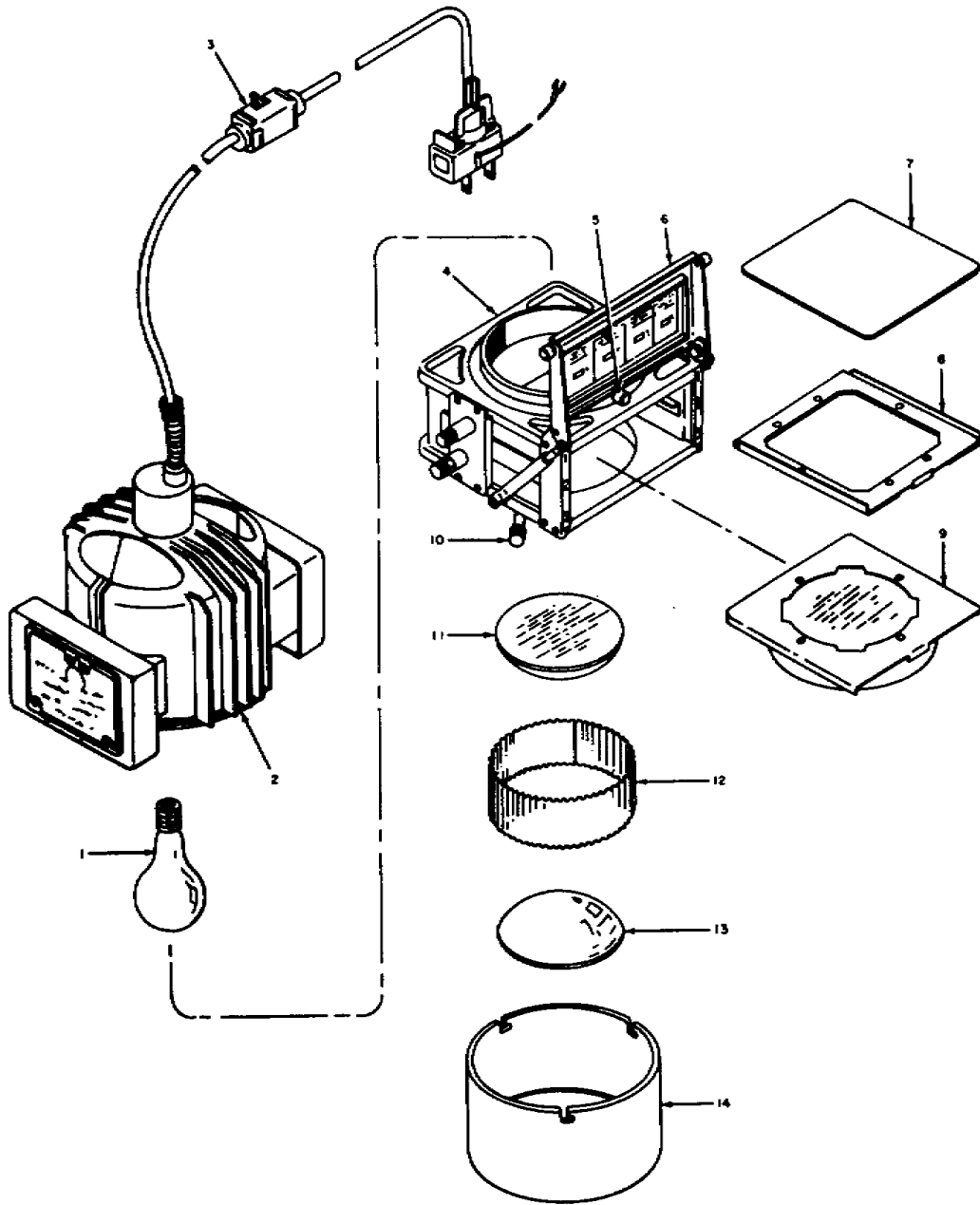

FIGURE 2-15. Lamp house assembly and condenser lens set disassembled.

- | | | | |
|----|---------------------------------|-----|-------------------------|
| 1. | Printer lamp | 8. | Color filter holder |
| 2. | Upper lamp house | 9. | Variable condenser lens |
| 3. | Power cable | 10. | Knurled screw |
| 4. | Variable condenser lens housing | 11. | Upper condenser lens |
| 5. | Thumbscrew | 12. | Lens separator |
| 6. | Access door | 13. | Lower condenser lens |
| 7. | Heat absorbing glass | 14. | Condenser lens housing |

b. Condenser lens replacement.

(1) Move the control lever (figure 2-14) forward and set it on the control lever stop.

CAUTION: The condenser lenses are not attached to the housing, and will fall out if the housing is inverted. Be careful not to drop the condenser lenses.

(2) Remove the condenser lens set (11 through 14, figure 2-15) by loosening the two knurled screws (10) and turning the condenser lens set slightly to release it.

(3) Place a lens tissue on the upper condenser lens (11) and, with the palm of one hand placed firmly over the lens tissue, tip the condenser lens set so that the upper condenser lens falls into hand.

(4) Turn the condenser lens housing (14) right side up and remove the lens separator (12) and the lower condenser lens (13).

(5) Clean and inspect the condenser lenses. Replace defective lenses.

(6) Replace one condenser lens with the plano (flat) side out, and then replace the lens separator (12) and the other condenser lens in the housing. Be sure that the plano side of each lens is out. Handle the lenses by the edges only.

(7) Position the condenser lens set under the variable condenser lens housing (4) so that the bayonet-type notches engage the knurled screws (10). Tighten the screws.

(8) Lower the lamp house assembly by releasing the control lever from the control lever stop.

2-35 Operator's Adjustments

Operator's adjustments on the printer are limited to adjusting the tension of the springs that secure the projection lens set by the use of the adjustment screws (figure 2-7). Tightening the screws increases the spring tension; loosening the screws decreases the spring tension. All other adjustments are to be performed by higher maintenance categories.

EXERCISE

17. When you are using the cleaning compound to remove grease, fungus, and ground-in dirt, what precautions must you take?

ANS: _____

18. You are making a projection print, but the desired image size cannot be obtained. What is the probable trouble, what should you check for, and what corrective measures should you take?

ANS: _____

19. What are the only two things that you, the operator, may replace on the printer when performing operator's maintenance?

ANS: _____, _____

SECTION 3

PROCESSING MACHINE, PHOTOGRAPHIC PAPER EH-91A

3-1 Scope

This section describes Processing Machine, Photographic Paper EH-91A [print processor (figure 3-1)], (this term will be used throughout this section), and covers its assembly, installation, operation, and operator's maintenance. It includes operation under usual conditions, cleaning and inspection of the equipment, and replacement of parts available for the operator.

3-2 Forms and Records

Reports of maintenance and unsatisfactory equipment. Use equipment forms and records in accordance with instruction given in TM 38-750 w/c 1, 2.

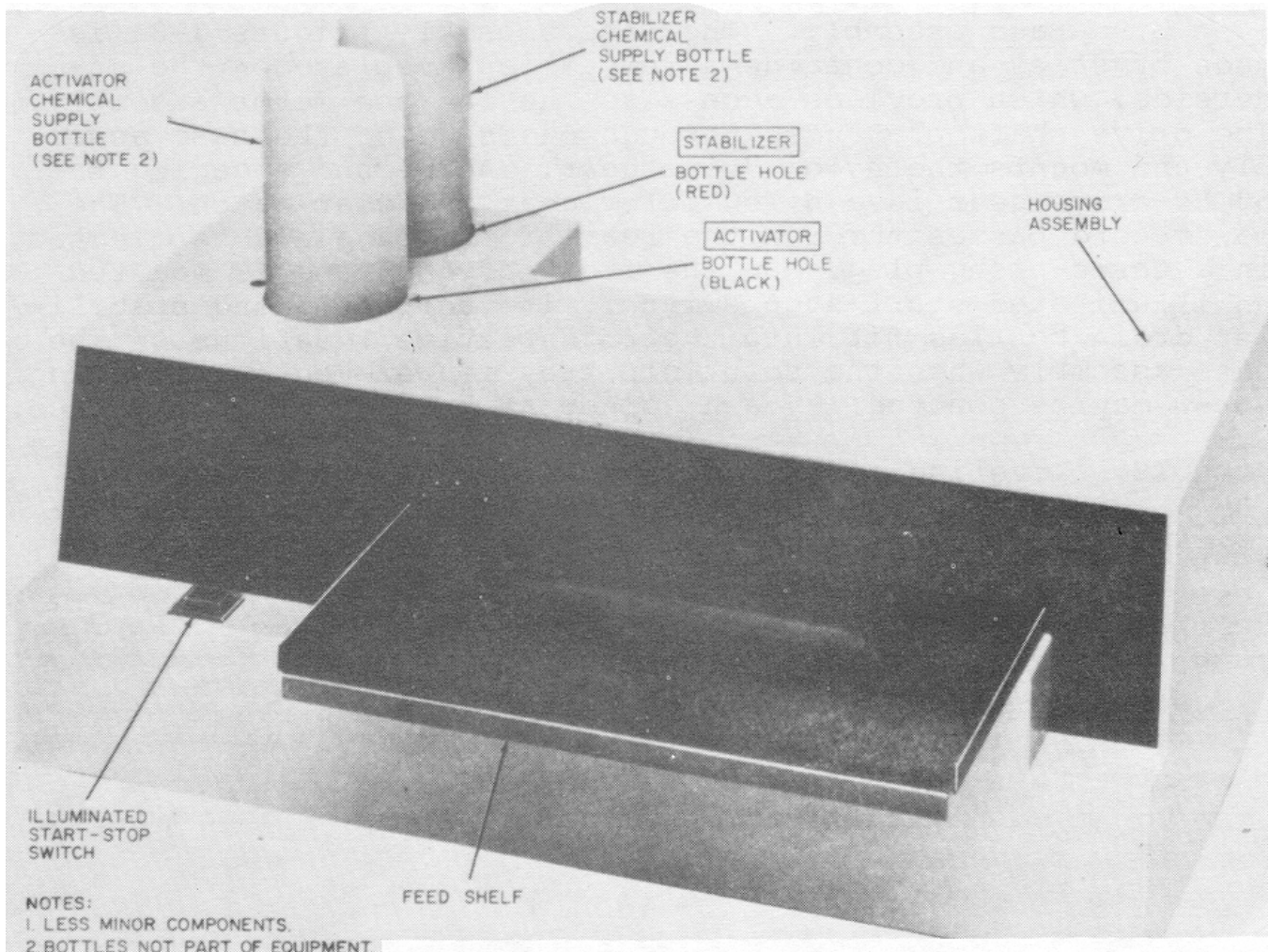

FIGURE 3-1. Processing machine, photographic paper EH-91A.

3-3 Purpose and Use

a. Purpose. The print processor is a self-contained automatic processing machine for development of stabilization type paper exposed by conventional contact and projection printing methods.

b. Use. The print processor is used in a fixed position in a darkroom. The print processor is equipped for 60-Hertz (Hz) operation when supplied as part of darkroom ES-82A (TM 11-6780-225-12, Appendix A).

3-4 Description of Equipment

a. Overall description. The print processor consists of the base assembly (b below), the solution tray (c below), the processing rack assembly (d below), the housing assembly (e below), the feed shelf (f below), and the valve assemblies (g below).

b. Base assembly. The base assembly (figure 3-2) is made of steel and contains a removable baseplate on the underside, which provides access to the fan and motor assembly. The drive shaft protrudes through one side of the base assembly and mounts the nylon drive gear. Above and engaging the 60 Hz drive gear is a nylon idler gear and gear latch. The power cord passes through the rear of the base and terminates in a three-prong plug. On the front of the base is mounted an illuminated start-stop switch. The activator and stabilizer drain bottles fit into their respective locations on the base assembly when the solution tray is removed. A leveling screw may be counted in each corner at the bottom of the base.

NOTE: Leveling screws are not used when print processor is supplied as part of the ES-82A (TM 11-6780-225-12, Appendix A).

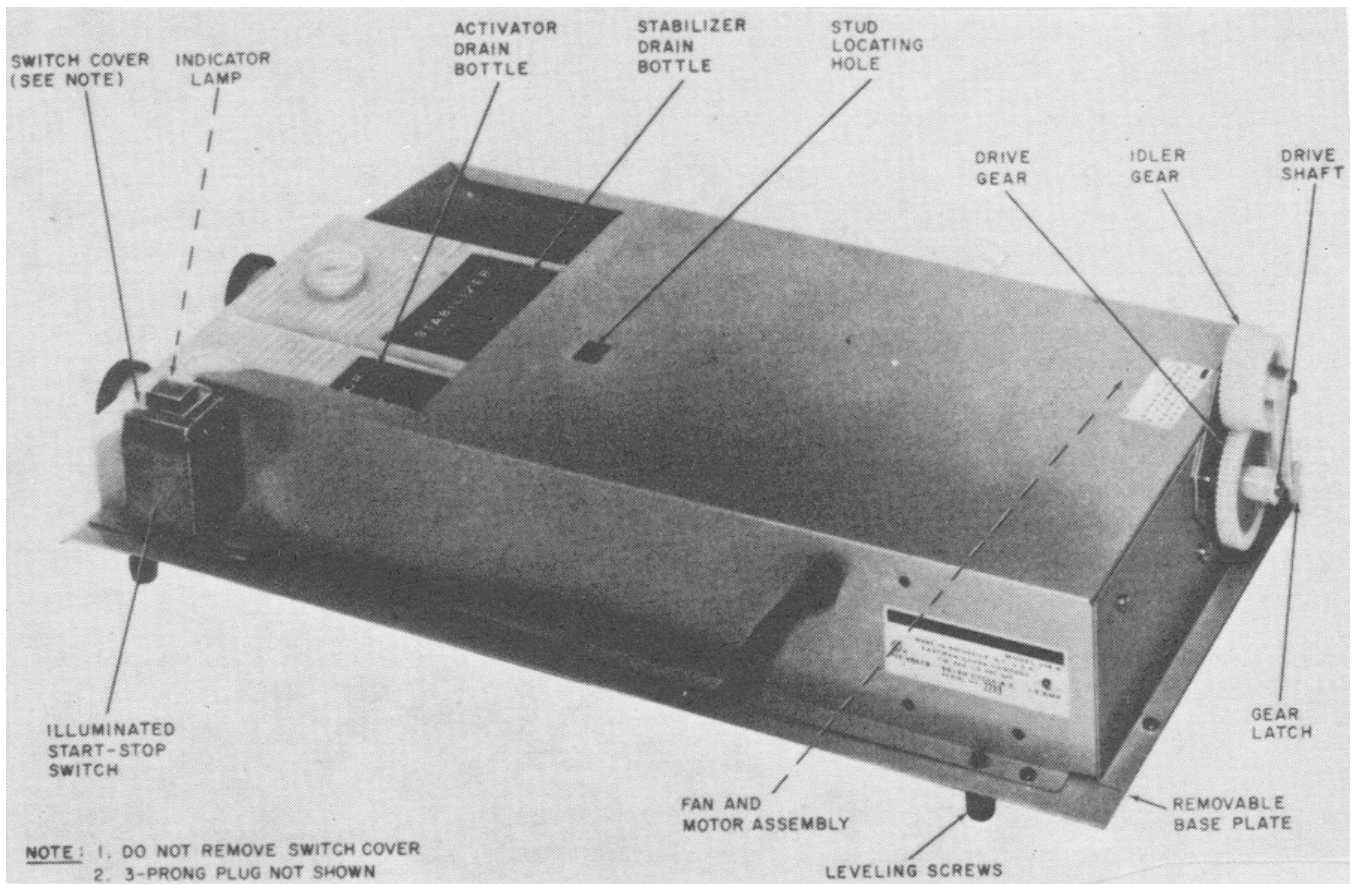

FIGURE 3-2. Base assembly.

c. Solution tray. The plastic solution tray (figure 3-3) is mounted on the base assembly and positioned by locating studs fitting into a stud locating hole (figure 3-2) at the top of base. The solution tray (figure 3-3) contains two plastic drain bellows which fit into the activator and stabilizer drain bottles, respectively. The drain bellows are compressed manually to empty the contents of the solution tray into the drain bottles.

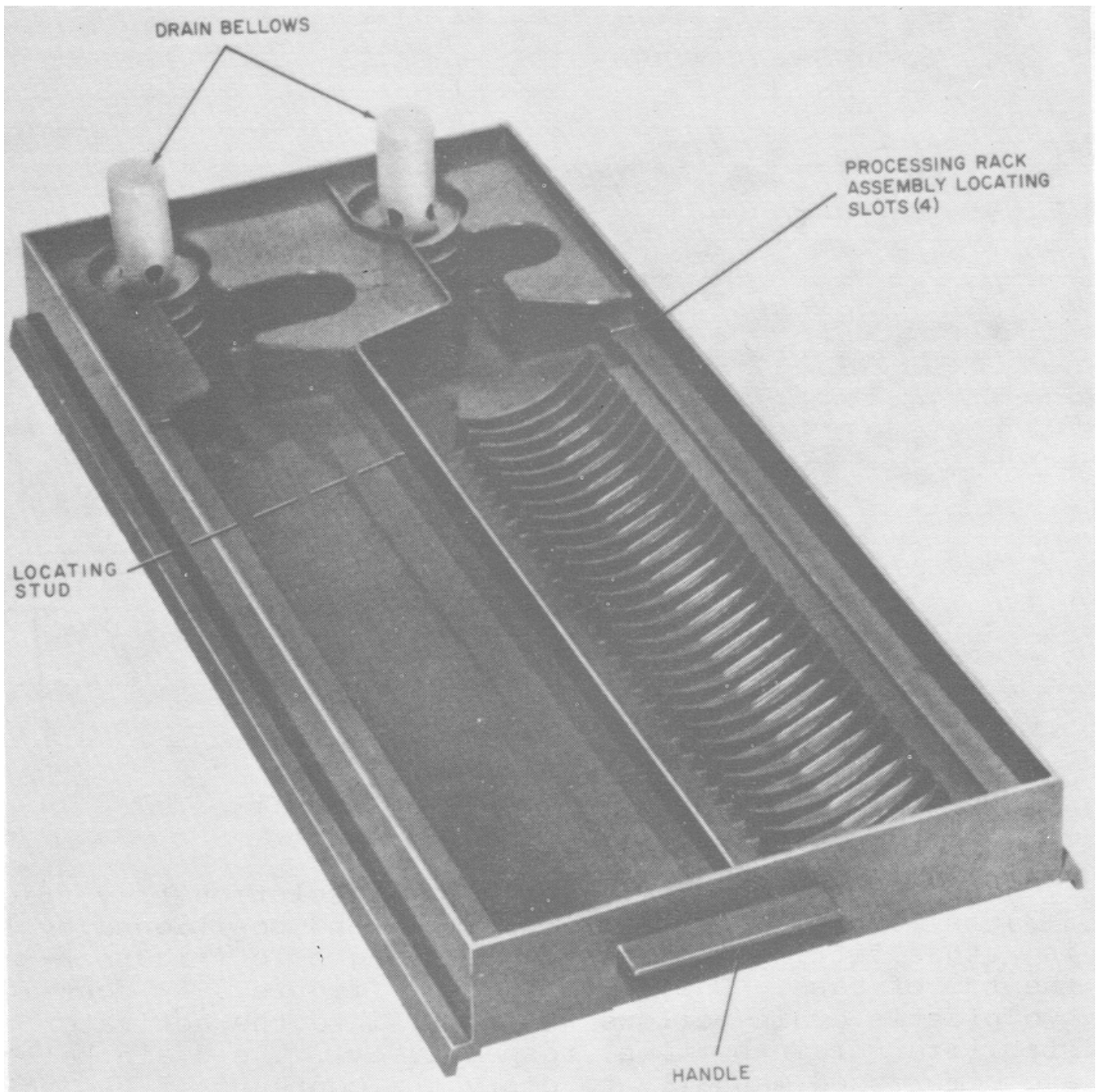

FIGURE 3-3. Solution tray.

d. Processing rack assembly. The processing rack assembly (figure 3-4) consists of 10 rubber rollers mounted on steel shafts driven by nylon gears with a 1:1 ratio, and two frame flanges. The tension of the rollers is preset by roller springs. The processing rack assembly mounts into the solution tray with the rack drive gear meshing with the idler

gear on the base assembly (figure 3-2), and is secured by the gear latch as shown in figure 3-8.

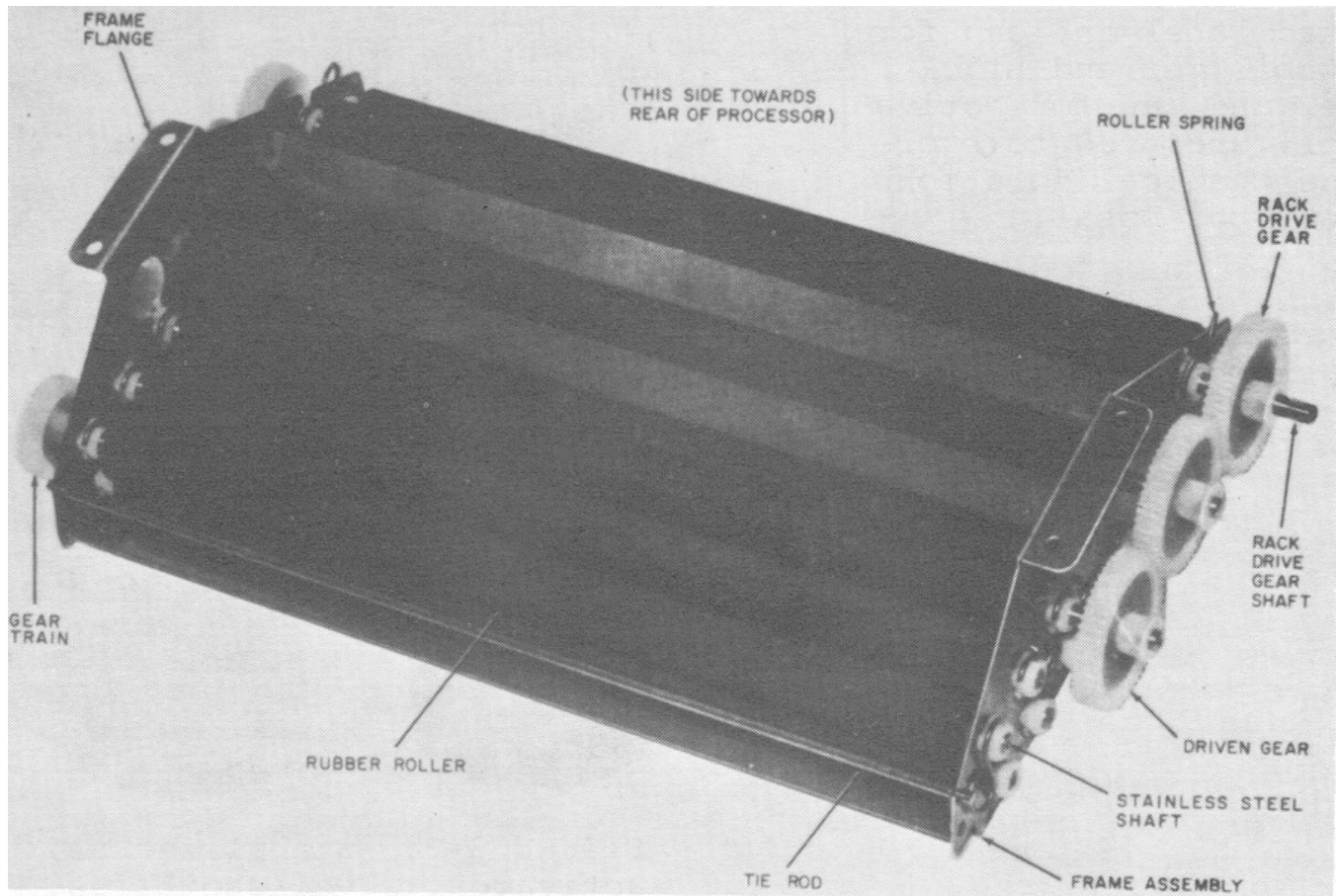

FIGURE 3-4. Processing rack assembly.

e. Housing assembly. The plastic housing assembly (figure 3-1) fits over the print processor, serving as a protective cover for the other components and provides bottle holes for the activator and stabilizer bottles.

f. Feed shelf. The feed shelf (figure 3-1) is a flat stainless steel tray which attaches to the processing rack assembly, and provides a guide for the exposed stabilization print into the print processor.

g. Valve assemblies. Two color-coded plastic spring-loaded valve assemblies (red for stabilizer and black for activator (figure 3-5) are used to maintain the correct level of each solution in the solution tray (figure 3-3). Each valve assembly (figure 3-5) is screwed onto the top of its corresponding stabilizer and activator chemical supply bottle (figure 3-11).

h. Drain bottles. Two plastic drain bottle assemblies (figure 3-2) (red label and cap for stabilizer and black label and cap for activator) are used to store the chemical solutions until disposal.

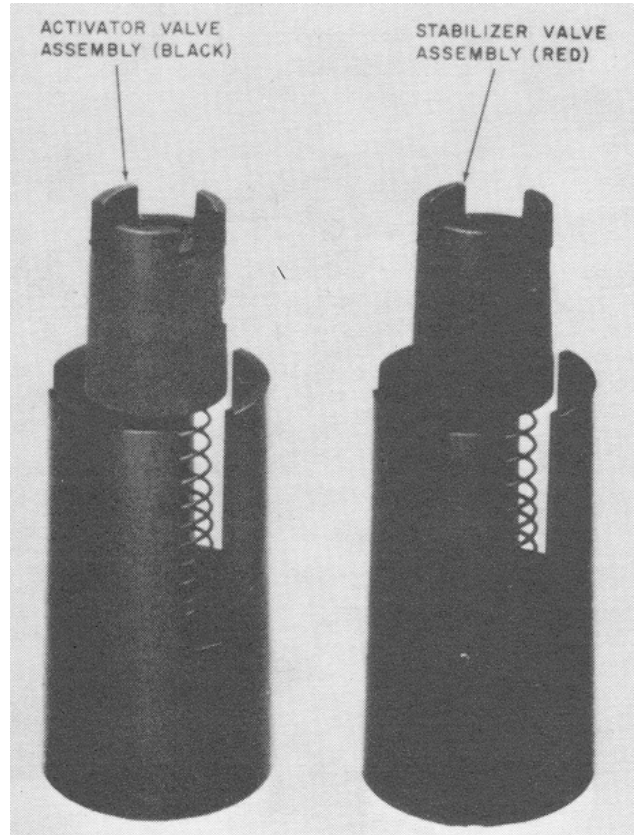

FIGURE 3-5. Stabilizer and activator valve assemblies.

EXERCISE

20. List all the major components of the print processor (not necessarily in any order).

ANS: _____

3-5 Installation Instructions

Siting. The print processor may be placed at any convenient waist-high location that will support its weight, not farther than 7.5 feet from a grounded receptacle. For greater ease of operation, the print processor should be located as close as possible to the printer or enlarger that will be used for exposing the stabilization type paper. Check to see that the print processor is level (para 3-8c, TM 11-6780-225-12, Appendix A, if the print processor is supplied as a part of the ES-82A). Check to see that the safelight in use has a Wratten Series OC filter and a 15-watt bulb and that it is not located closer than 4 feet to the print processor.

3-6 Assembly of Components

a. Assembly of activator and stabilizer drain bottles.

(1) Screw the drain bottle caps securely on the threaded ends of the drain bottles as shown in figure 3-6.

(2) Insert the stabilizer drain bottle (red label) inside and to the rear of the base assembly, with the top opening facing up.

(3) Insert the activator drain bottle (black label) inside and to the front of the base assembly.

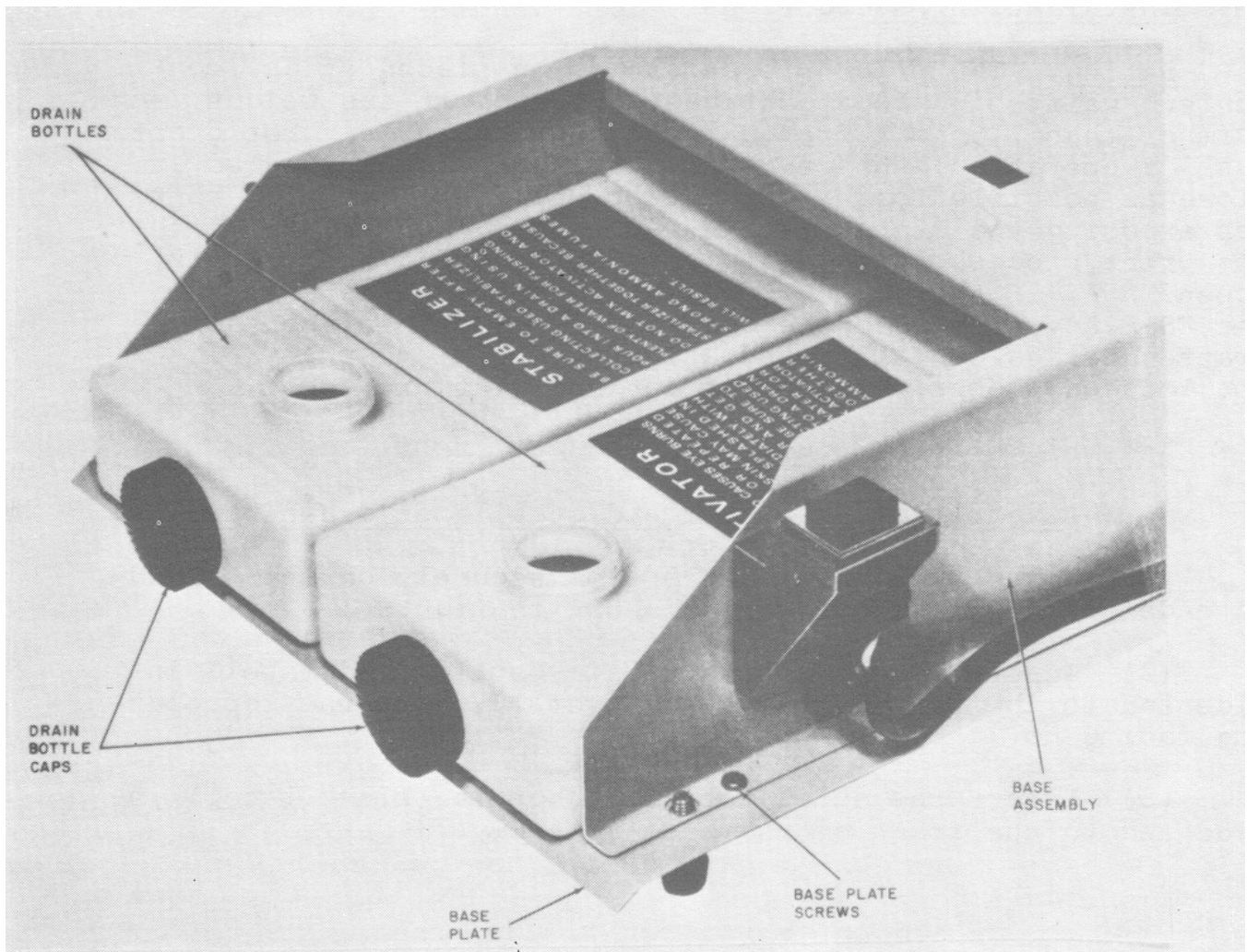

FIGURE 3-6. Assembly of activator and stabilizer drain bottles.

b. Assembly of solution tray (figure 3-7).

(1) Check to see that the solution tray (figure 3-3) is clean (para).

(2) Place the solution tray on top of the base assembly with the drain bellows to the left, so that the locating stud on the bottom of the solution tray mates with the stud locating hole (figure 3-2) on the top of the base assembly.

(3) Make certain that the opening at the bottom of each drain bellow mates with the opening at the top of each drain bottle.

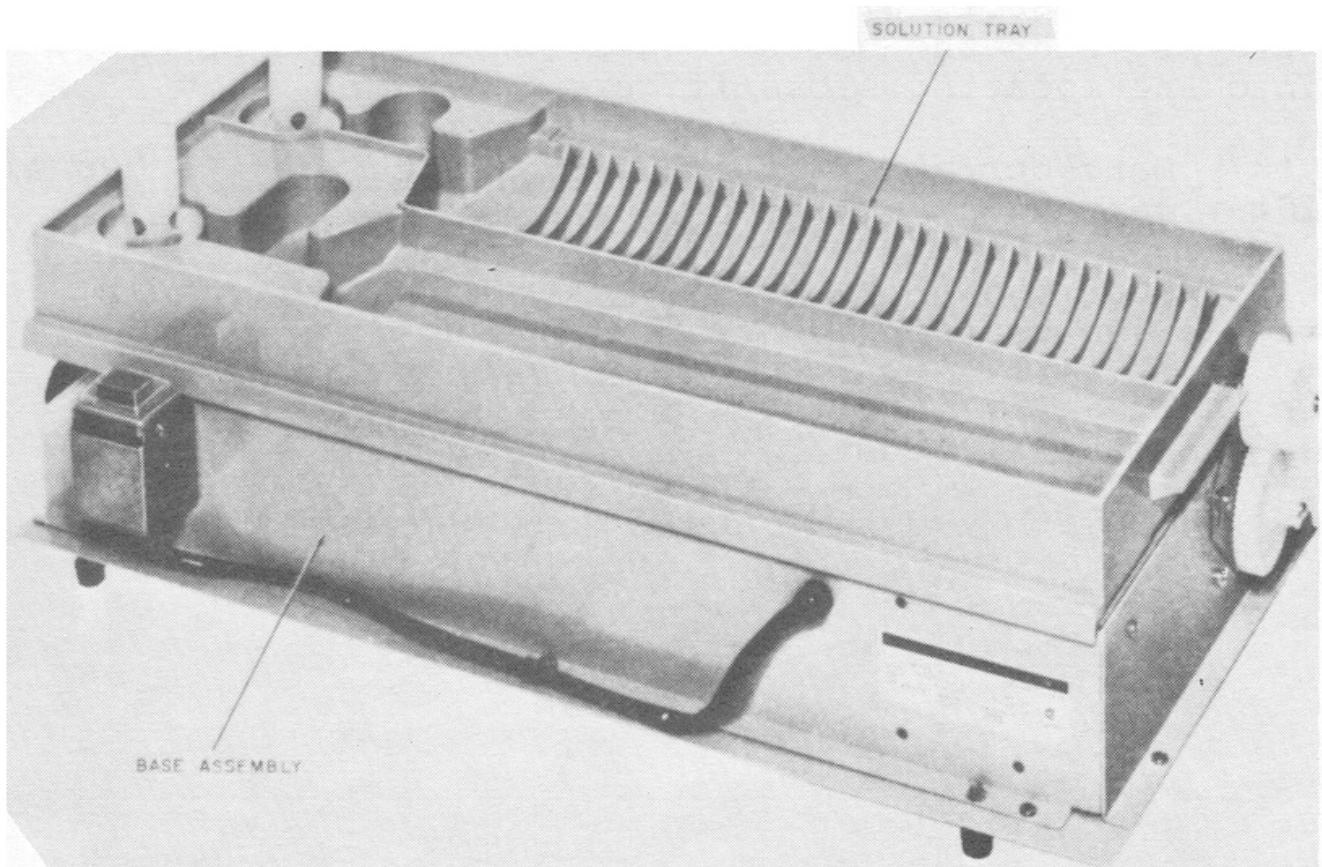

FIGURE 3-7. Solution tray assembled with base assembly.

c. Assembly of processing rack assembly (figure 3-8).

(1) Check to see that the processing rack assembly (figure 3-4) is clean (para 3-15).

(2) Check to see if the driven gear (figure 3-8) is assembled; if not, install as described in (3) through (6) below.

(3) Insert the roller drive pin into the roller shaft.

(4) Make certain that the hole in the roller shaft is horizontal.

(5) Slide the driven gear onto the roller shaft, with the hub of the gear toward the processing rack assembly until the gear hub encloses the roller drive pin.

(6) Push the Teflon retaining washer on the roller shaft until it seats in the groove on the roller shaft.

(7) Grasp the processing rack assembly by the frame flanges and with the driven gear toward the right side of the print processor, place the rack assembly in the solution tray so that the bottom edges of the frame assembly fit into the locating slots (figure 3-3).

(8) Make certain that the rack driven gear meshes with the idler gear (figure 3-8) of the base assembly.

(9) Snap the gear latch over the shaft protruding from the rack drive gear on the processing rack assembly.

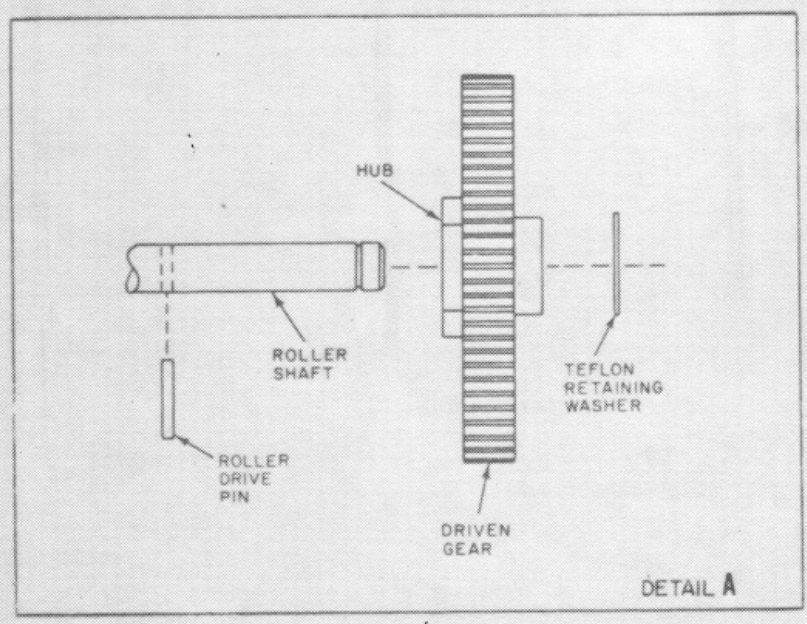
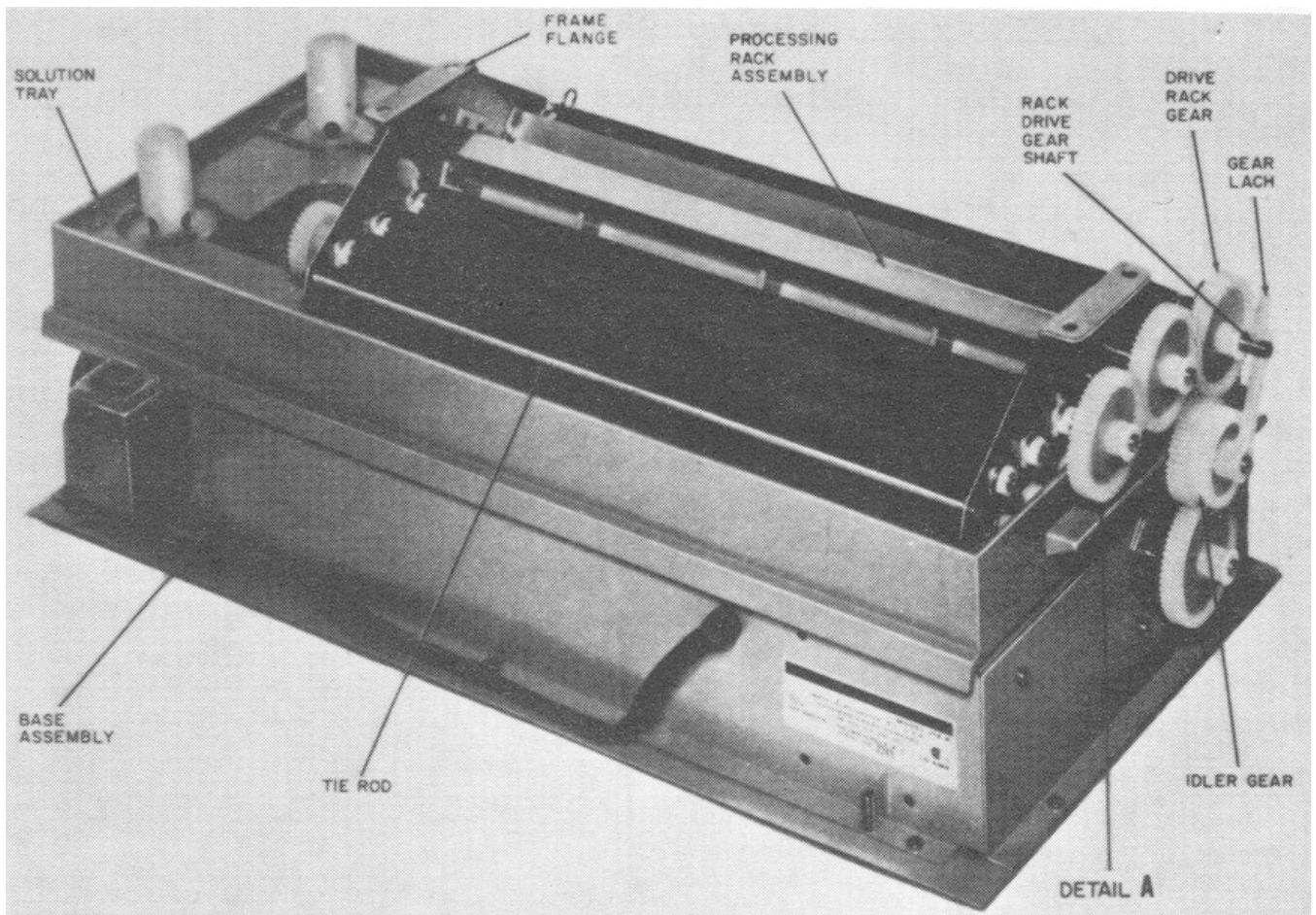

FIGURE 3-8. Assembly of processing rack assembly.

d. Assembly of housing assembly.

(1) Assemble the housing assembly (figure 3-1) onto the print processor as follows:

(2) Tilt the front of the housing assembly upward and toward the rear of the print processor hooking the hinge shaft (figure 3-9) under the two brackets mounted on the rear of the base assembly (figure 3-10).

(3) Gently lower the front of the housing assembly until it seats properly and securely.

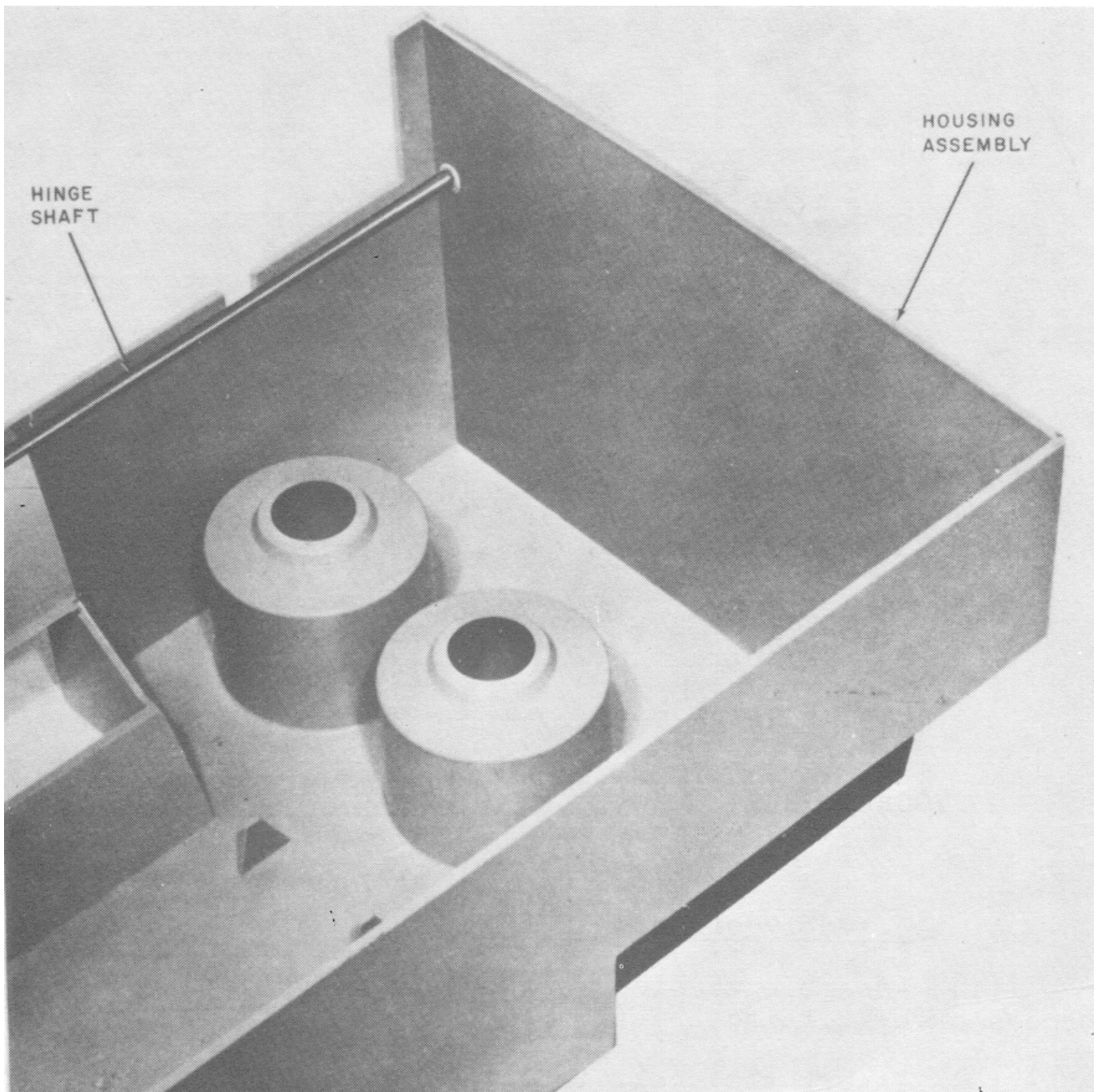

FIGURE 3-9. Housing assembly, bottom view.

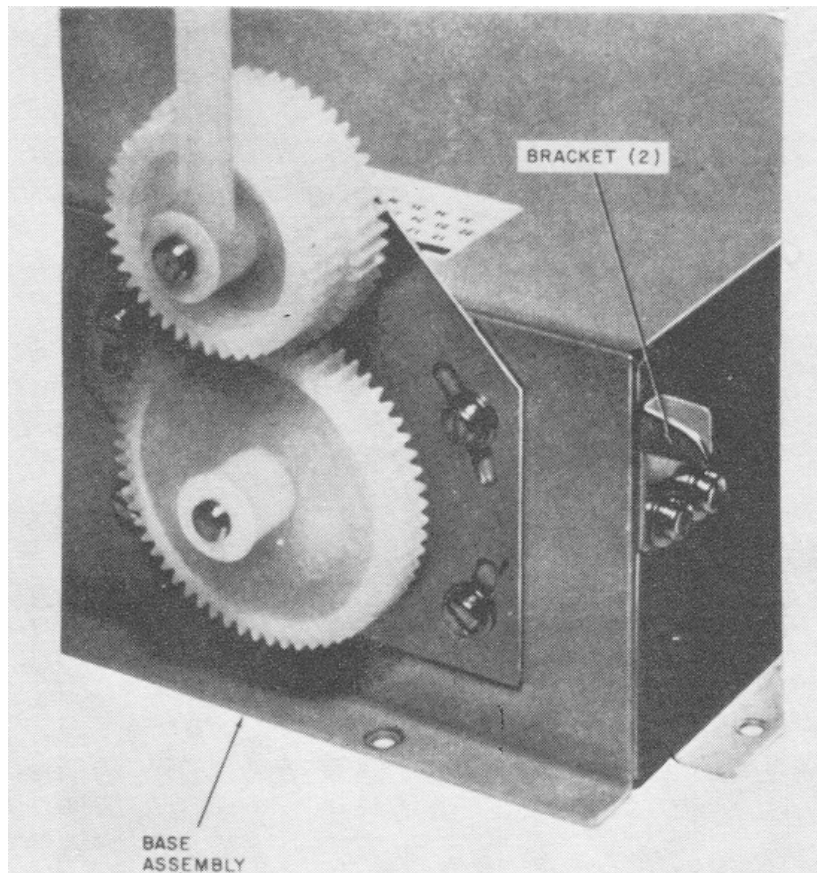

FIGURE 3-10. Bracket location for assembly of housing assembly.

e. Assembly of feed shelf.

(1) Assemble the feed shelf (figure 3-1) to the print processor by tilting the front upward.

(2) Insert the shelf into the housing assembly as far as it will go, then lower the front of the shelf until it is securely in place.

(3) This motion hooks the rear of the feed shelf to the tie rod (figure 3-4).

CAUTION: To avoid any possibility of contaminating solutions, always use the black valve assembly with the activator and the red valve assembly with the stabilizer (para 3-12).

f. Assembly of stabilizer and activator valve assemblies to chemical supply bottles.

(1) Remove the cap from each of the one-quart chemical supply bottles.

(2) Screw a valve assembly onto each bottle as shown in figure 3-11.

(3) Tighten each valve assembly securely.

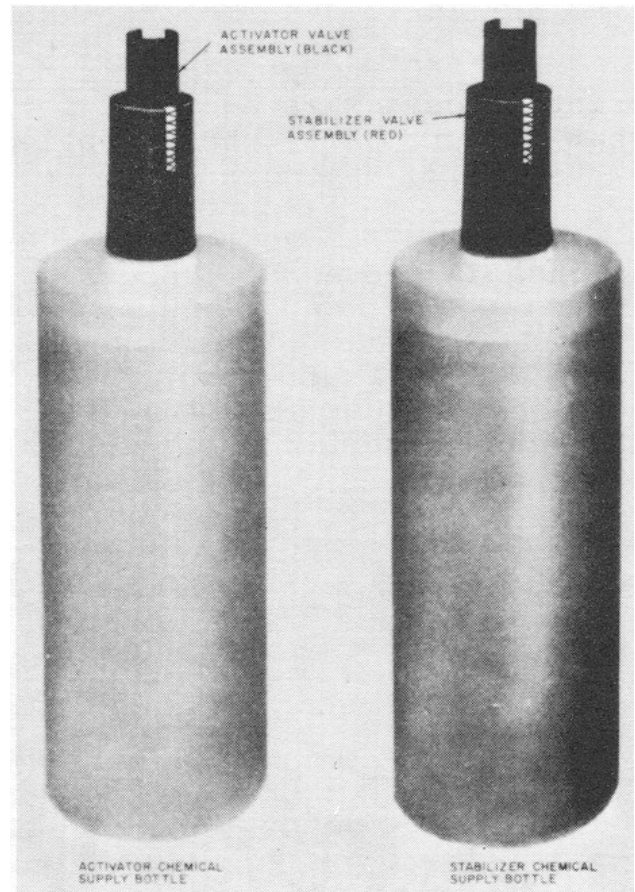

FIGURE 3-11. Assembly of stabilizer and activator valve assemblies to chemical supply bottles.

3-7 Checking Installation

a. Before applying power to the print processor, remove the feed shelf (figure 3-1) and remove the housing assembly [para 3-12d(6)].

b. Check that the gear latch (figure 3-8) is securely positioned over the rack drive gear shaft.

c. Rotate the rack gear by hand to ascertain that all other gears and rollers operate smoothly.

d. Replace the housing assembly and feed shelf (para 3-6d and e).

3-8 Initial Adjustment of Equipment

a. 60 Hz drive gear removal for 50 Hz operation. The print processor is equipped for operation with the 60 Hz drive gear (figure 3-12) when supplied as part of the ES-82A (TM 11-6780-225-12, Appendix A).

(1) To remove the 60 Hz drive gear, release the gear latch and remove the processing rack assembly and solution tray.

(2) Pull off the Teflon retaining washer and slide the 60 Hz drive gear from the drive shaft, being careful to catch the gear drive pin as it falls from the drive shaft.

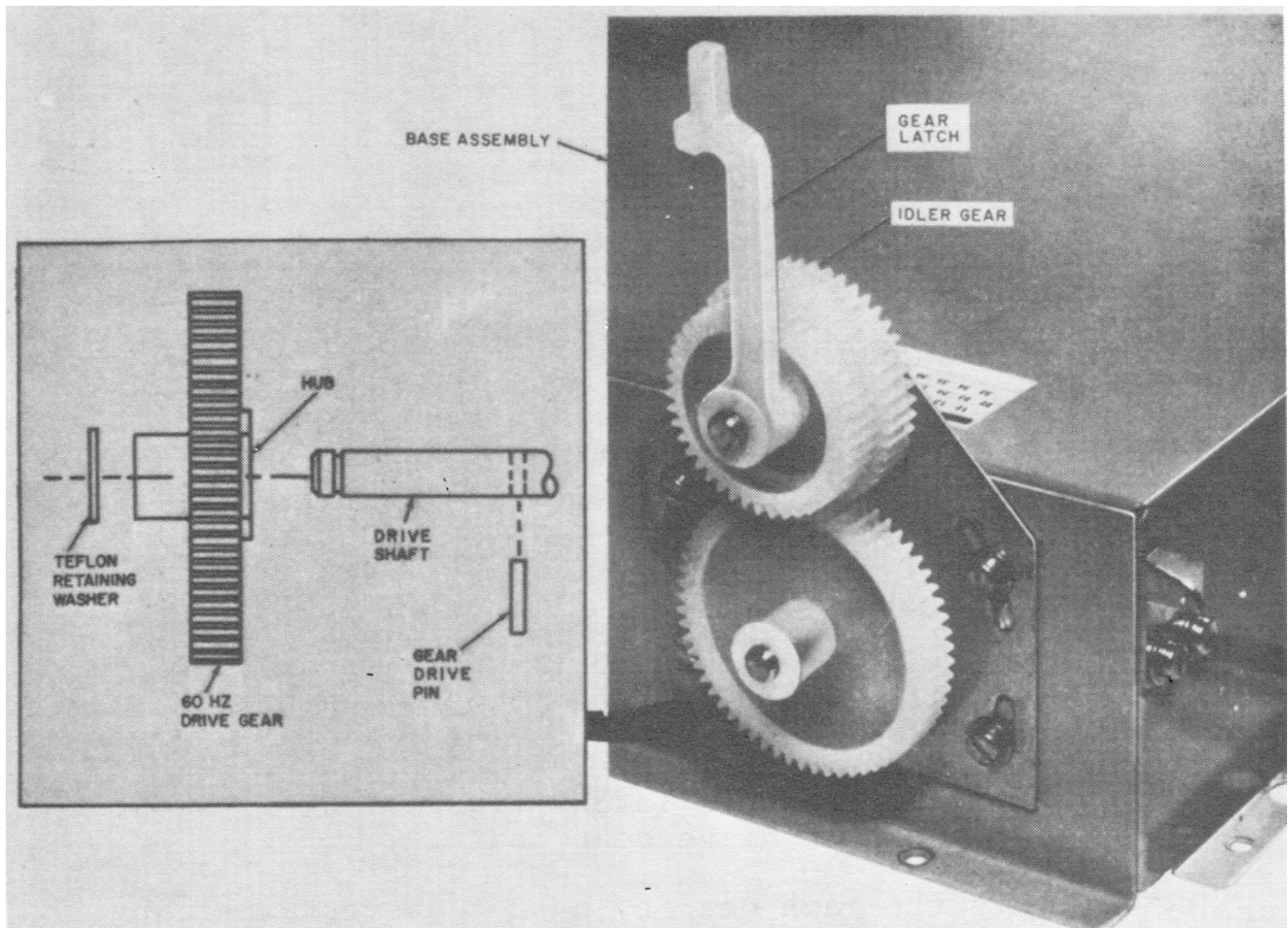

FIGURE 3-12. 60 Hz drive gear removal.

b. 50 Hz drive gear installation for 50 Hz operation. If it is necessary to install the 50 Hz drive gear (figure 3-13), remove the 60 Hz drive gear as described in a above.

(1) To install the 50 Hz drive gear, insert the gear drive pin into the motor shaft, holding the pin in place with a screwdriver blade or similar object.

(2) Slide the 50 Hz drive gear onto the drive shaft with the hub of the gear toward the base assembly until the gear hub encloses the gear retaining pin.

(3) Push the Teflon retaining washer onto the drive shaft until it seats in the groove on the motor shaft.

(4) Replace the solution tray and processing rack assembly (para 3-6b and c).

(5) Snap the gear latch over the rack drive gear shaft (figure 3-13).

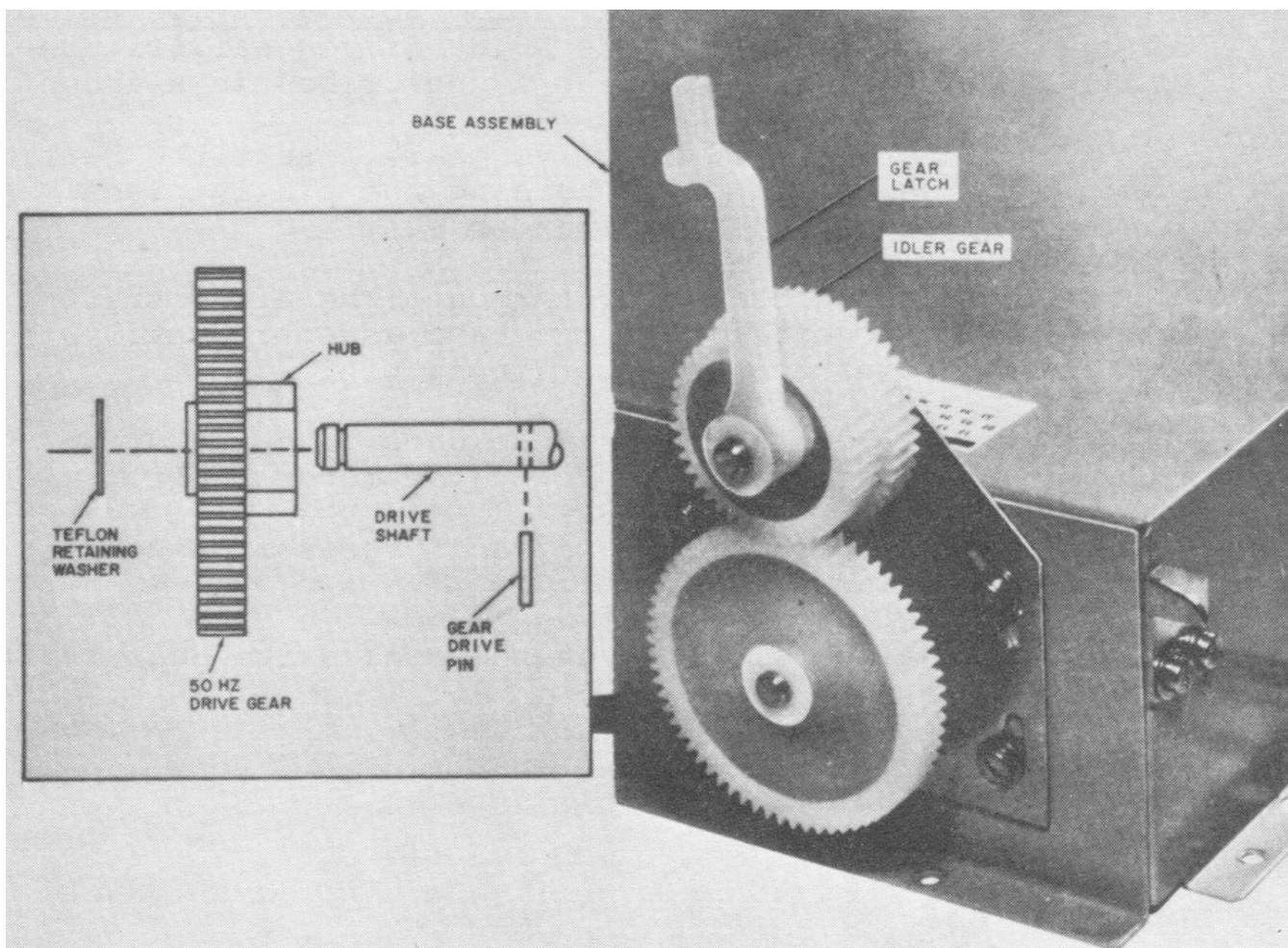

FIGURE 3-13. 50 Hz drive gear installation.

CAUTION: The print processor must be leveled, as described below, each time it is moved to a new location.

c. Leveling print processor. Leveling of the print processor may be accomplished as follows:

(1) Place the activator drain bottle in position in the base assembly (figure 3-2) before mounting the solution tray (para 3-6a), then mount the solution tray on the base assembly (para 3-6b).

(2) Fill the front section of the solution tray with water (figure 3-14) and adjust the leveling screws until the water is at the same height along the entire length of the center partition.

(3) Front to rear adjustment can be checked by comparing the water level against the height of the flat surfaces near the front drain bellows.

(4) Drain the water from the tray by depressing the drain bellows (figure 3-16).

(5) Remove the solution tray and empty the activator drain bottle.

(6) Replace the drain bottle and solution tray (para 3-6a and b) and reassemble the print processor (para 3-6).

(7) If the print processor is supplied as part of the ES-82A, refer to TM 11-6780-225-12, Appendix A.

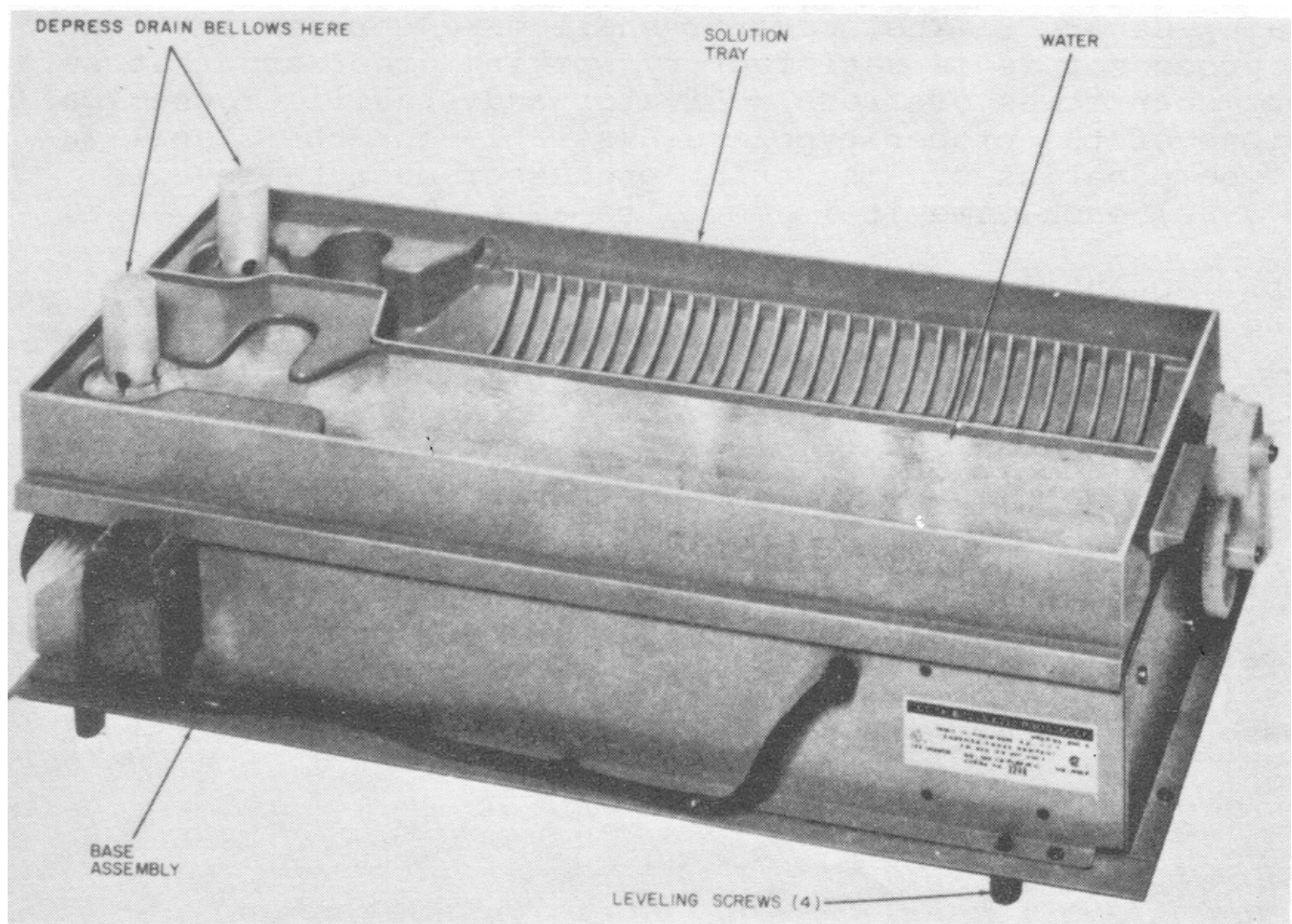

FIGURE 3-14. Leveling print processor.

EXERCISE

21. When setting up the print processor, the distance to a power source should not be farther than: (select one)

- a. 5 feet.
- b. 10 feet.
- c. 7.5 feet.
- d. 3 feet.

22. When changing the drive gear from 60 Hz to 50 Hz, the hub on the new drive gear must be facing _____

_____.
(complete statement)

23. A simple way to insure that the solution tray and the print processor stands level is to use _____

_____.
(complete statement)

3-9 Operating Instructions

a. General. The operator shall make certain that the print processor is in satisfactory working order and that sufficient quantities of fresh activator and stabilizer chemical solutions of the proper type are available for the stabilization type paper used. The print processor must be leveled (para 3-8c) each time it is moved to a new location.

b. Quantity of chemicals required. For the initial filling of the solution tray of the print processor, 30 ounces of activator and 40 ounces of stabilizer are required. After the solution tray is filled, a one-quart bottle of activator and a one-quart bottle of stabilizer must be installed to maintain correct levels of solutions in the solution tray.

c. Chemical life. The activator and stabilizer chemical solutions shall be discarded and replaced with fresh chemicals after approximately three hundred 8" x 10" in prints (or the equivalent area in other sizes) have been processed, or after one week's use, whichever comes first.

3-10 Operator's Controls and Indicators

<u>Control or Indicator</u>	<u>Function</u>
Illuminated start-stop switch (figure 3-2)	Starts or stops print processor.
Indicator lamp	Glows red when print processor is operating.

3-11 Preliminary Procedures

CAUTION: BE CERTAIN THE ACTIVATOR CHEMICAL SUPPLY BOTTLE IS INSERTED IN THE FRONT OPENING MARKED ACTIVATOR, AND THAT THE STABILIZER CHEMICAL SUPPLY BOTTLE IS INSERTED IN THE REAR OPENING MARKED STABILIZER. AFTER INSTALLING THE VALVE ASSEMBLIES ON THE CHEMICAL SUPPLY BOTTLES (PARA 3-6f), HOLD THE BOTTLES ABOVE THE PRINT PROCESSOR, TURN THEM BOTTOM SIDE UP AND QUICKLY INSERT THEM INTO THEIR RESPECTIVE BOTTLE HOLES (figure 3-1). REFER TO PARAGRAPH 3-9b FOR THE QUANTITY OF ACTIVATOR AND STABILIZER CHEMICAL SOLUTIONS REQUIRED.

3-12 Operating Under Normal Conditions

CAUTION: Do NOT operate the print processor if the switch cover (figure 3-2) has been removed.

a. Starting print processor. Depress the illuminated start-stop switch (figure 3-1). When the indicator lamp is illuminated, the print processor is operating and ready for use.

CAUTION: Always insert the exposed print (emulsion side down) into the print processor. Do not touch the emulsion side of the print before processing.

NOTE: If the print processor is to be used intermittently, operate it for one minute before inserting the first sheet of exposed stabilization type paper.

b. Developing exposed stabilization type paper. Place the exposed print to be developed (emulsion side down) on the feed shelf, and feed the print into the print processor as shown in figure 3-15. Always feed the exposed print into the

print processor squarely. With a 14-inch wide print, use an edge of the feed shelf to align the print squarely with the rollers.

CAUTION: To avoid chemical contamination of the feed shelf, do not allow developed prints to come in contact with the feed shelf or housing assembly as they are removed.

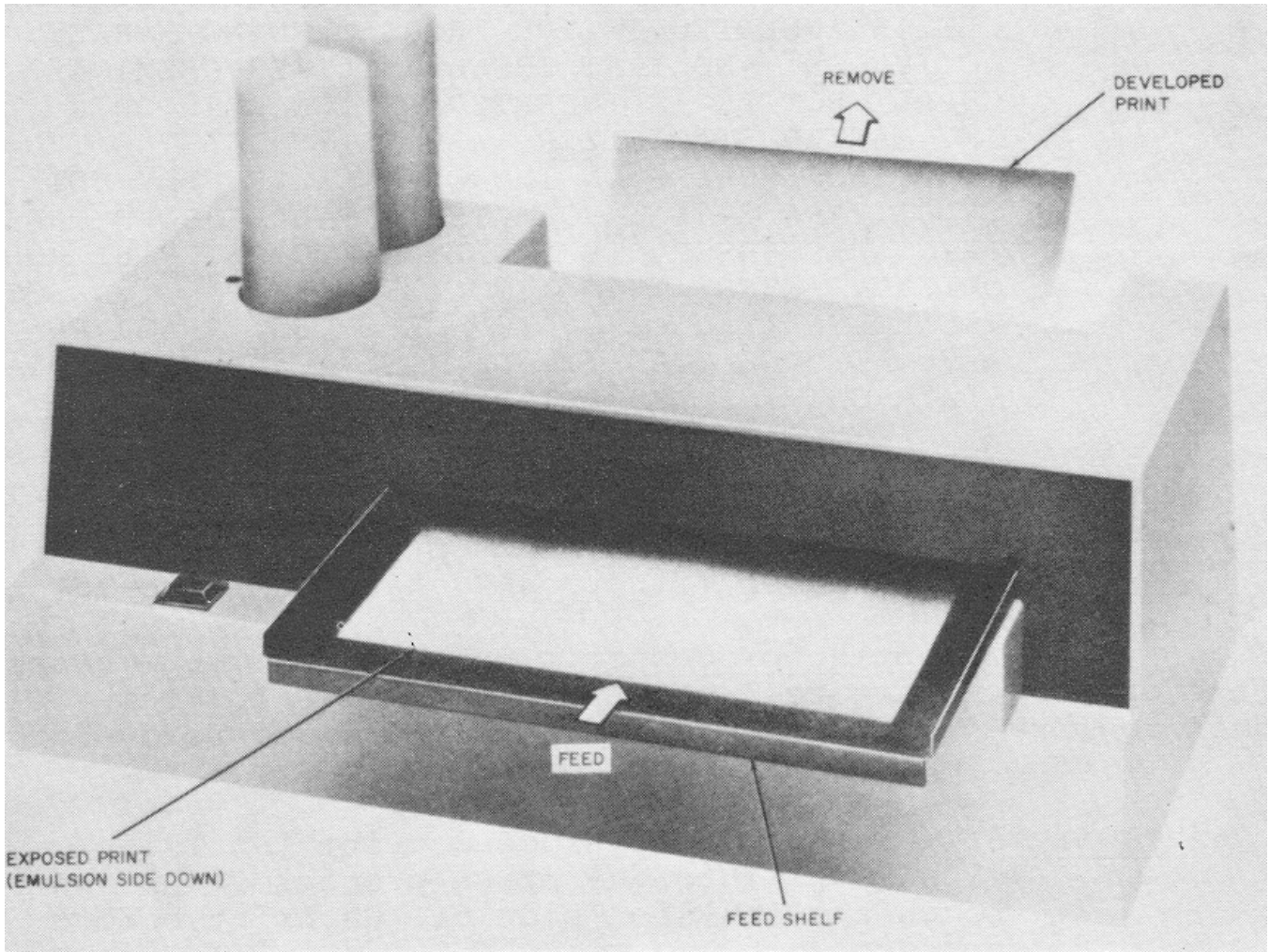

FIGURE 3-15. Feeding and removal of prints from print processor.

c. Removal of developed prints from print processor. As the developed print emerges from the print processor (figure 3-15), grasp the lead edge of the print and apply slight tension to be certain the trail edge is pulled free

as it leaves the final roller of the processing rack assembly. Failure to do this may result in a paper jam, or excessive moisture on the trailing edge of the print, which would cause nonuniformity. When developing a photomechanical print, stiffen the lead edge of the print by folding a 2-inch tab, emulsion to emulsion, straight across the lead edge. This tab will prevent a lightweight print from wrapping around the rubber rollers.

d. Replacement of activator and stabilizer chemical supply bottles and emptying drain bottles. To replace the activator and stabilizer chemical supply bottles, proceed as follows:

WARNING: Before refilling chemical supply bottles (figure 3-1) with fresh chemicals, label one bottle Activator with black ink and label the other bottle Stabilizer with red ink. The activator may cause eyeburns. Prolonged or repeated contact with skin may cause irritation. If activator is splashed in the eyes, flush eyes immediately with cool water for 15 minutes and get medical attention.

(1) Depress the illuminated start-stop switch (figure 3-2) until indicator lamp is extinguished.

(2) Remove the activator and stabilizer chemical supply bottles (figure 3-1).

(3) Remove the valve assemblies (figure 3-11) from the chemical supply bottles. Rinse the valve assemblies thoroughly in cold water and shake to dry. If chemical supply bottles are to be refilled, rinse each thoroughly with cold water and drain dry. If chemical supply bottles are not to be refilled, they may be discarded after rinsing.

(4) Screw the activator valve assembly (black) on the new or refilled activator chemical supply bottle. Screw the stabilizer valve assembly (red) on the new or refilled stabilizer chemical supply bottle. Store [at a temperature of 65° to 85° F (18° to 29° C)] the two chemical supply bottles to await installation.

(5) Remove the feed shelf (figure 3-1J) from the print processor.

(6) Remove the housing assembly from the print processor by lifting the housing assembly upward from the front and then lifting it rearward until the hinge shaft (figure 3-9) is free of the brackets (figure 3-10).

(7) Depress and hold down the drain bellows, as shown in figure 3-16, until both used chemical solutions have drained from the solution tray into their respective drain bottles.

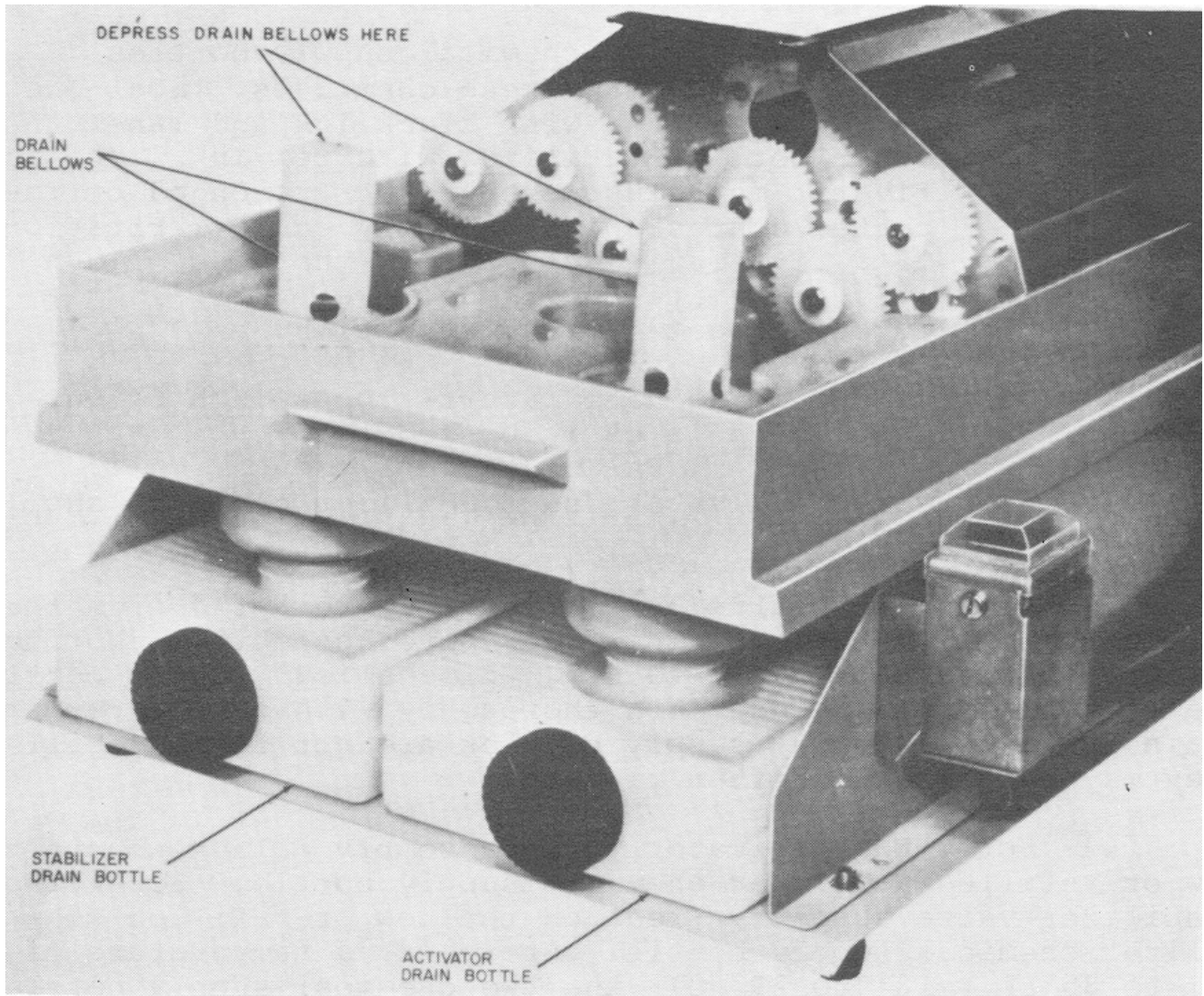

FIGURE 3-16. Emptying drain bottles.

(8) Disengage the gear latch (figure 3-2). Raise the left side of the solution tray by the handle (figure 3-3).

While holding a towel or large sponge under both drain bellows to prevent dripping, lift the solution tray and processing rack assembly as a unit and carry it to a sink. Remove the processing rack assembly (figure 3-4) from the solution tray and clean both (para 3-15).

(9) Remove the caps from the ends of the activator and stabilizer drain bottles (figure 3-6) and screw them securely on the openings at the top of their respective drain bottles.

WARNING: Do NOT mix activator and stabilizer solutions. Mixing these solutions causes toxic ammonia fumes. Dispose of used solutions one at a time in a sink, flushing with water thoroughly while pouring each solution. The activator solution may cause eyeburns and prolonged or repeated contact with the skin may cause irritation. If activator is splashed in the eyes, flush eyes immediately with cool water for 15 minutes and get medical attention.

(10) Carefully remove the drain bottles from the base assembly. Remove the caps from the top openings of the drain bottles. Discard the used solutions in a sink, one at a time, flushing thoroughly with water while pouring each solution into the sink. Rinse each cap thoroughly in water before replacing it (para 3-6a).

(11) Rinse and replace the drain bottles in the base assembly.

(12) Reassemble the solution tray, processing rack assembly, housing assembly, and feed shelf (para 3-6).

(13) When ready to develop the exposed paper (stabilization type), install the activator and stabilizer supply bottles containing fresh chemicals from (4) above, and as described in para 3-11.

e. Shutdown procedure. For a shutdown not exceeding 12 hours, with usable solutions in the print processor (para 3-9c), depress the illuminated start-stop switch (figure 3-1) until the indicator lamp (figure 3-2) is extinguished. Ascertain that the ambient temperatures will remain 65° to 85° F (18° to 29° C). For a shutdown exceeding 12 hours, remove the activator and stabilizer chemical supply bottles. Upon restarting the print processor, replace the activator and stabilizer chemical supply bottles (d above) and allow it to run for 5 minutes before developing the first exposed print.

EXERCISE

24. What is the maximum recommended amount of prints there should be processed before you must change or add chemicals?

ANS: _____

25. When feeding an exposed sheet of stabilization type paper into the print processor, which way must the emulsion side face?

ANS: _____

26. When storing the activator and stabilizer chemical when in use on the print processor, the recommended temperature must be: (select best answer)

- a. 35° to 55° F.
- b. 55° to 65° F.
- c. 65° to 85° F.
- d. 85° to 95° F.

27. After the print processor has been shut down for more than 12 hours, how long must it be allowed to run before you should process the next exposed stabilization type print paper?

ANS: _____

3-13 Scope of Operator's Maintenance

The maintenance duties assigned to the operator of the print processor are listed below together with references to the paragraphs covering specific maintenance functions. The tools and materials required are listed in paragraph 3-14.

- a. Cleaning (para 3-15).
- b. Daily preventive maintenance checks and services (para 3-17).
- c. Weekly preventive maintenance checks and services (para 3-18).
- d. Troubleshooting (para 3-19).

3-14 Tools and Materials Required for Operator's Maintenance

The following tools and materials are required for operator's maintenance.

- a. Trichlorethane.
- b. Mild soap.
- c. Lint-free cloth or sponge.
- d. Soft bristle brush.

3-15 Cleaning

- a. Remove dust and loose dirt with a clean, soft cloth.

WARNING: The fumes of trichloroethane are toxic. Provide thorough ventilation whenever used. DO NOT use near open flame. Trichloroethane is not flammable, but exposure of the fumes to an open flame converts the fumes to highly toxic, DANGEROUS GASES.

CAUTION: Do not use trichloroethane on rubber rollers of processing rack assembly (figure 3-4).

- b. Grease, fungus, and ground-in dirt. Remove grease, fungus, and ground-in dirt, using a cloth dampened (not wet) with trichloroethane.

c. Gears. Remove dust and dirt from gears with a brush. If difficulty in removing dirt occurs, dampen the cloth with water; mild soap may be used to make the cleaning more effective.

d. Solution tray, housing assembly, and feed shelf. Clean the solution tray (figure 3-3), housing assembly, and feed shelf (figure 3-1) thoroughly with mild soap, cool water and a lint-free cloth or sponge. Rinse them thoroughly in cool water for 5 minutes. Allow them to drain dry or wipe dry with a clean, lint-free cloth. Make certain all water is removed from drain bellows of the solution tray (figure 3-3).

CAUTION: Do not soak the processing rack assembly (figure 3-4) in water.

e. Processing rack assembly. Clean the processing rack assembly by thoroughly rinsing it in cool water for 5 minutes. Place the processing rack assembly on its frame flanges on a flat surface; allow to drain dry.

f. Base assembly. Clean only the exterior surfaces of the base assembly (figure 3-2) with a lint-free cloth moistened with trichloroethane.

g. Drain bottles and valve assemblies. Rinse the drain bottles and caps (figure 3-7) and valve assemblies (figure 3-5) thoroughly in cool water for 5 minutes; allow them to drain dry.

CAUTION: Check to see that labels have not been removed from drain bottles during cleaning.

3-16 Operator's Preventive Maintenance Checks and Services Periods

a. Paragraph 3-17 specifies checks and services that must be accomplished daily and under the special conditions listed below:

(1) when the print processor is initially installed.

(2) when the print processor is reinstalled after removal for any reason.

(3) at least once each week if the print processor is not used daily, but is maintained in standby condition (i.e., ready for immediate use).

b. Paragraph 3-18 specifies additional checks and services that must be performed once each week.

3-17 Operator's Daily Preventive Maintenance Checks and Services

Sequence No.	Item to be inspected	Procedure	Reference
1	Chemical supply bottles	Make certain that there are sufficient amounts of chemical solutions in activator and stabilizer chemical supply bottles.	Para 3-12

Sequence No.	Item to be inspected	Procedure	Reference
2	Feed shelf and exterior of housing assembly	Clean with clean lint-free cloth or sponge moistened with trichloroethane.	Para 3-15
3	Quality of developed print	Observe developed print as it emerges from the print processor for chemical stains and indication of overdevelopment due to improper speed of processing rack assembly.	Para 3-20

3-18 Operator's Weekly Preventive Maintenance Checks and Services

Sequence No.	Item to be inspected	Procedure	Reference
1	Power cord	Check for fraying, cuts and worn insulation. Check for bent or broken prongs on plug.	Refer to higher category of maintenance for replacement.
2	Feed shelf, housing assembly, and chemical supply bottle holes	Clean.	Para 3-15
3	Solution tray and processing rack assembly	Clean.	Para 3-15
4	Illuminated start-stop switch and indicator lamp	Check for smooth operation and that indicator lamp illuminates when print processor is operating.	Refer to higher category of maintenance for repair or adjustment.

Sequence No.	Item to be inspected	Procedure	Reference
5	Processing rack assembly	Check for smooth operation, freedom of binding, and no excessive looseness.	Refer to higher category of maintenance for repair or adjustment.

3-19 General Troubleshooting Information

Troubleshooting the print processor is based on the operational checks in the daily and weekly preventive maintenance checks and services chart. To troubleshoot the print processor, perform all the functions in the daily and weekly preventive maintenance checks and services charts (para 3-17 and 3-18) until an abnormal condition or result is observed. Perform the checks and corrective measures indicated in the troubleshooting chart (para 3-20). If the corrective measures indicated do not result in correction of the trouble, a higher category of maintenance is required.

3-20 Operator's Troubleshooting Chart

Item No.	Trouble symptom	Probable trouble	Checks and corrective actions
1	Indicator lamp does not illuminate and print processor does not operate when illuminated start-stop switch is depressed.	<ul style="list-style-type: none"> a. Print processor not connected to power source. b. Illuminated start-stop switch defective. 	<ul style="list-style-type: none"> a. Connect print processor to power source. b. Replace defective switch (refer to higher category of maintenance).
2	Chemical stains on developed prints.	Chemical contamination of feed shelf.	Clean feed shelf (para 3-15).
3	Prints emerging from print processor wet.	Improper roller pressure.	Adjust roller pressure (refer to higher category of maintenance).
4	Prints emerging from print processor undeveloped.	<ul style="list-style-type: none"> a. Exhausted activator chemical solution. 	<ul style="list-style-type: none"> a. Replace activator chemical solution (para 3-12).

Item No.	Trouble symptom	Probable trouble	Checks and corrective actions
		<ul style="list-style-type: none"> b. Processing rack assembly not operating at proper speed. c. Print fed into print processor incorrectly. d. Solution level too low in solution tray. 	<ul style="list-style-type: none"> b. Check that correct drive gear (50 or 60 Hz) (para 3-8a or b) has been installed. Check voltage at power source. c. Feed prints into print processor, emulsion side down. d. Check solution level in chemical supply bottles (para 3-12).
5	Developed image of print becoming dark too rapidly.	Exhausted stabilizer chemical solution.	Replace stabilizer solution (para 3-12).
6	Developed prints do not emerge from print processor.	Print jammed in processing rack assembly.	Remove jammed print from processing rack assembly.

3-21 Preparing Print Processor for Travel

Perform the following operations:

a. Remove the activator and stabilizer chemical supply bottles and drain solution tray [para 3-12d(5) through (7)]. Do not refill the print processor with chemical solutions until travel is completed.

b. Remove the processing rack assembly by reversing the instructions given in paragraph 3-6c. Store the processing rack assembly in a secure location, free from vibration and shock.

NOTE: If the print processor is supplied as part of the ES-82A, refer to TM 11-6780-225-12, Appendix A.

c. Store the feed shelf (figure 3-1) in a separate location from the print processor.

d. With gummed paper tape, tape the solution tray to the base assembly and after assembling the housing assembly, secure the bottom sides of the housing assembly to the underside of the base assembly with gummed paper tape.

EXERCISE

28. When using trichloroethane for cleaning the processing machine, you must make sure that you have?

ANS: _____

29. Trichloroethane should NOT be used as a cleaning material on the following parts of the print processor: (select one)

- a. base assembly
- b. gears
- c. drain bottles and valve assemblies
- d. processing rack assembly

30. There are two types of maintenance checks and services you must perform when doing operator's preventive maintenance and they are: (select one)

- a. daily, monthly
- b. weekly, daily
- c. monthly, quarterly
- d. None of the above.

3-22 Records and Reports

Records and reports of these checks and services must be made in accordance with the requirement set forth in TM 38-750 w/c 1, 2.

SUMMARY

You have now completed Lesson 2 which covers the basic types of laboratory print producing machine(s) (equipment). We have covered the basic operation and operator's preventive maintenance of each. The types of equipment you might come in contact with from time to time may not be the exact same model or number, but the principals are the same as long as you work with a contact printer, enlarger, or print processor. You have to maintain them in order to be able to produce top quality work. Never fall behind on preventive maintenance.

EXERCISE SOLUTIONS

LESSON 2

1. c, (para 2-1)
2. permits setting of margins to desired print size (para 2-1)
3. c, (para 2-4)
4. Raise or lower the diffusion glass as necessary. (para 2-5)
5. to prevent the development of defects (para 2-6)
6. Remove glass and wash with soapy water. (para 2-8)
7. the operator and unit repairman (para 2-10)
8. The ruby safe lamp should light automatically. (para 2-11)
9. preparatory, start, equipment performance, stop (para 2-13)
10. to give maximum brightness of the projected image (para 2-22)
11. Raise or lower the carriage assembly and refocus each time. (para 2-22)
12. Position the two slots of the horizontal projection attachment under the heads of the knurled screws. (para 2-24)
13. Emulsion side must be up. (para 2-24)
14. cleaning compound, lens cleaner, lens tissue, textile cloth (para 2-27)
15. TM 38-750 (para 2-28)
16. physical and operational checks (2-30)
17. provide adequate ventilation and not near any open flame (para 2-32)

18. Improper combination of variable condenser lens position and projection lens selection; use proper projection lens with correct condenser lens position. (para 2-33).
19. printer lamp, condenser lens (para 2-34)
20. base assembly, housing assembly, feed shelf, valve assemblies, drain bottles (para 3-4)
21. c. 7.5 feet (para 3-5)
22. toward the base assembly (para 3-8)
23. water in the activator tray (para 3-8)
24. approximately 300 8" x 10" prints (para 3-9)
25. down (para 3-12)
26. c, (para 3-12d)
27. 5 minutes (para 3-12e)
28. plenty of ventilation and not near open flame (para 3-15)
29. d, (para 3-15)
30. b, (para 3-16)

LESSON 3

PHOTOGRAPHIC FINISHING EQUIPMENT

SCOPE

In this lesson we will talk about the photographic equipment that is used for the last steps in the photographic process. This includes the drying of processed film, washing of photographic (newly developed) prints, and drying of the washed photographic prints. We will cover ONLY the equipment operation and operator's maintenance of each piece of equipment.

SECTION 1

PHOTOGRAPHIC PRINT WASHER, EK-1

3-1 Description and Data

a. General. Washer EK-1 is designed to wash photographic prints for the purpose of removing the fixing solution. A constant flow of water, aided by a rotating cylinder (figure 3-1), circulates the prints to provide constant agitation. The machine is equipped with manually regulated inlet and outlet valves to adjust the rate of water flow and displacement.

b. The overall dimensions of the washer are 23" x 36" x 35".

3-2 Component Parts of Washer EK-1 (figure 3-1)

Washer EK-1 consists of the following major components: frame, cylinder (drum), tank, transmission, motor, and cylinder lift.

a. Washer frame (figure 3-1). The frame, together with the four legs which are bolted to it, provides support for the motor, transmission, cylinder lift units, cylinder, and tank.

b. Cylinder (figure 3-1). The cylinder is a perforated stainless steel drum which holds the prints during washing. It has a hinged door with door locks for convenient loading and unloading. An index pin, located on each lift channel, holds the cylinder in position when it is raised and the door turned upward. Attached to each end of the cylinder is a stub shaft that rests in the rubber bearing of the lift channel to

support the cylinder. These shafts, resting in the rubber bearings, permit cylinder rotation. Two rollers in the bottom of the tank contact the cylinder surface to drive the cylinder in its lowered position. The cylinder may be raised from the tank during operation.

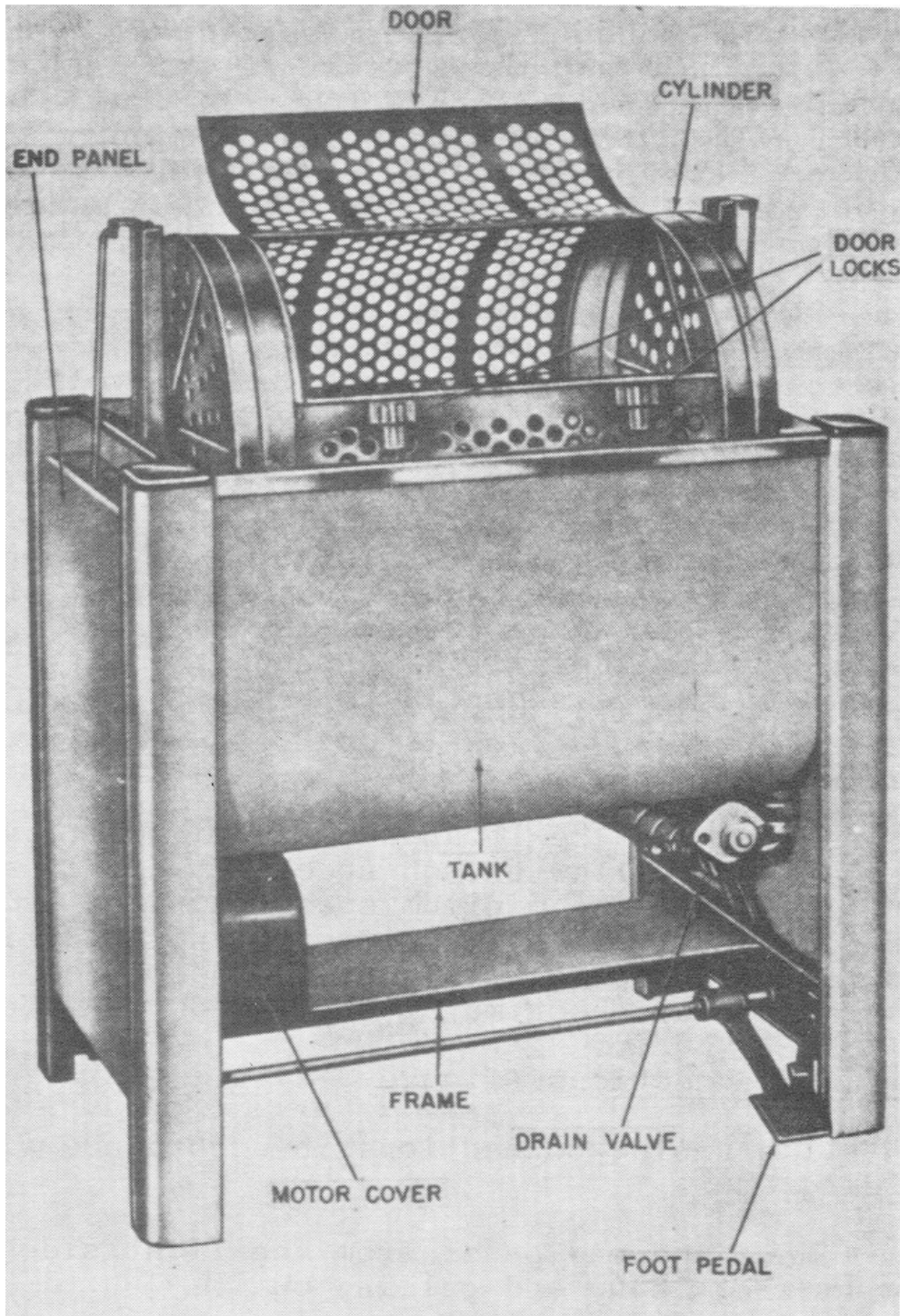

FIGURE 3-1. Washer EK-1, in position for receiving prints.

c. Tank (figure 3-1). The tank is supported by the four legs to which the frame is bolted. It has a water inlet and overflow outlet on the right side. The drain valve is bolted to the bottom under the drain outlet. The inlet pipe assembly, cylinder rollers, and roller shaft are located on the inside of the tank. The outside surface is painted for ease of maintenance.

d. Transmission. The transmission consists of a simple reduction pulley system (figures 3-3 and 3-4). The motor pulley is fastened to the motor shaft. The reduction pulley revolves on a pulley stud which is mounted to the upright bracket on the frame. The driven pulley is attached to the left end of the roller shaft where it emerges from the tank. Two belts, the motor belt and the drive belt, transmit the power from the motor to the roller shaft.

e. Motor (figure 3-1). The motor is a 1/20-hp (horsepower) splitphase type which operates on 115-volt, 60-cycle ac (alternating current). A 6-foot power cord with a two-prong plug is provided for electrical connection.

f. Cylinder lift (figure 3-1). The cylinder lift consists of the foot pedal, pedal shaft, two lift rods, and two lift levers. The foot pedal and lift levers are fastened to the pedal shaft which rotates in the frame. The lift rods are fastened to the lift levers and the lift channels which ride in the guide channels in the tank.

3-3 Location

The washer should be located in the laboratory near fresh water connections. Allow enough space between it and other equipment or walls. The minimum space required is 37" x 24", but allowance must be made for plumbing and electrical connections and for maintenance work. Level the washer, if necessary, by placing wooden or metal shims under the legs.

3-4 Plumbing Connections (figure 3-2)

Make all plumbing connections in accordance with the plumbing diagram.

a. Remove the end panel from the right side of the washer by lifting it up and pulling out.

b. Connect the drain valve to a 1 1/4-inch drain pipe with the rubber hose and hose clamps provided.

c. Connect the water inlet fittings to a 1/2-inch water line with any necessary pipe fittings. Install two 1/2-inch valves in tandem in the water supply line, one for shut-off and the other for regulating.

NOTE: The two valves and all pipe fittings installed must be brass or stainless steel to prevent rust and dirt from being carried into the print washer.

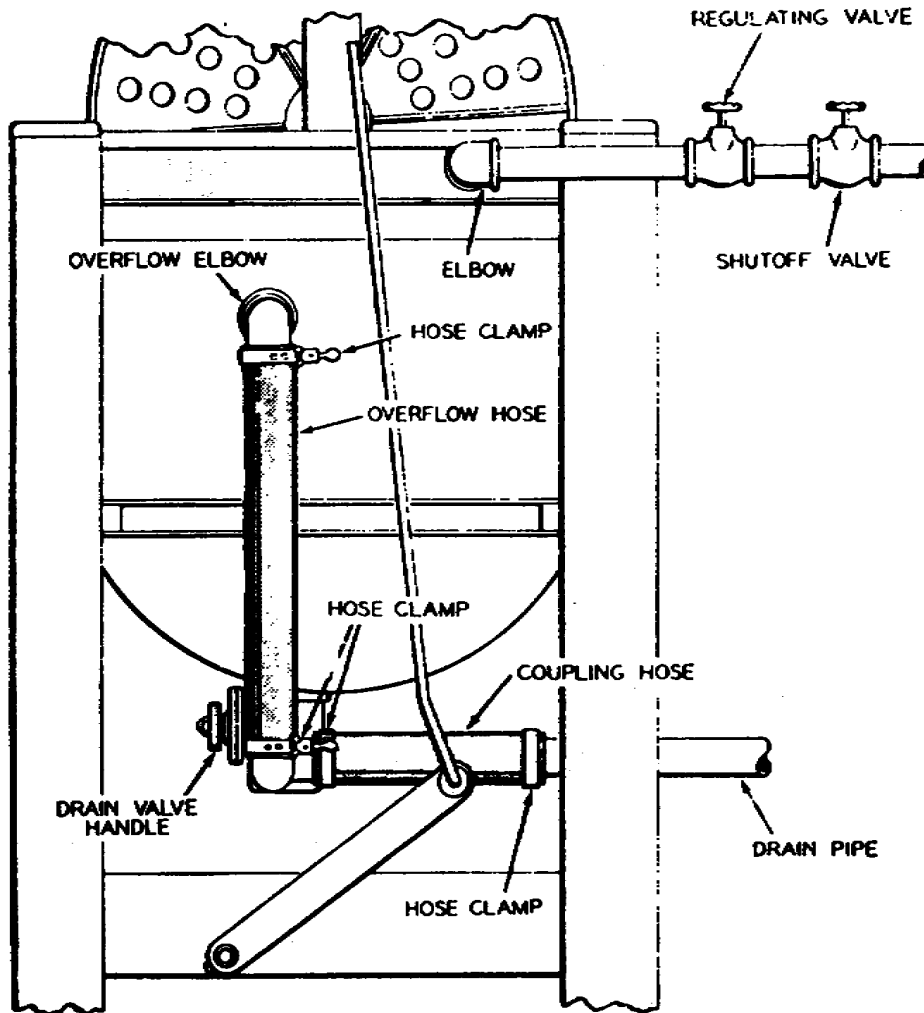

FIGURE 3-2. Plumbing diagram for Washer EK-1.

- d. Make sure all hose clamps are tightened securely.
- e. Hang the end panel in place on the right side of the washer.

3-5 Electrical Connections

a. This washer is equipped with a power cord which must be plugged into a 115-volt, 60-cycle power outlet and will carry a total of 125 watts. Install a DISCONNECT (power ON-OFF) switch of proper size and electrical rating in the power line at a point where it will be convenient for the operator.

b. The cylinder must revolve toward the operator as he faces the machine (para 3-9, item 2).

3-6.1 Preliminary Lubrication

Lubricate the print washer as described in paragraph 3-11. The stuffing box is lubricated with graphite and should not require further lubrication even though the washer has been in storage for some time.

EXERCISE

1. What is the voltage recommended to safely operate the EK-1 Washer?

ANS: _____

3-6.2 Controls

a. Foot pedal. The foot pedal (figure 3-1) is used to raise and lower the cylinder in the tank. To raise the cylinder, push down on the foot pedal far enough to allow the pedal lock to hold the pedal down. To lower the cylinder, push down on the foot pedal to release the pedal lock and allow the pedal to raise slowly.

b. Drain valve. The drain valve (figure 3-2) is used to empty the tank after operation (para 3-11). Turn the valve handle counterclockwise to open the valve and clockwise to close the valve.

NOTE: The valve is designed so that only slight pressure on the diaphragm, inside the valve, is necessary to shut off the flow of water. Excessive tightening will damage the diaphragm.

c. Door lock. The two door locks (figure 3-1) on the cylinder slide over the end of the hinged door. Simply push the door locks up or down to lock or unlock the door.

3-7 Operation

a. Placing washer in operation.

(1) Drain hypo from prints before washing them to decrease washing time.

(2) Close the drain valve (figure 3-2).

(3) Open the water shut-off valve (figure 3-2) and allow the tank to fill to overflow. Leave the valve from one-half to three-quarters open to maintain a continuous flow of fresh water.

(4) Raise the cylinder by stepping on the foot pedal (figure 3-1). Engage the pedal lock to hold the foot pedal down.

(5) Rotate the cylinder by hand until the door is on top and the index pin on each lift channel engages the cylinder to hold it in place.

(6) Release the door locks and open the door.

(7) Place the prints in the cylinder, one by one, so that they do not stick together.

(8) Close and lock the door.

(9) To lower the cylinder in the tank, step on the foot pedal to release the pedal lock, and allow the pedal to rise slowly.

(10) Turn on the power switch to start the motor.

NOTE: No other equipment is used with the washer as part of the washing operation.

b. Washing time.

Variations in chemical characteristics, temperature, and rate of flow of wash water, as well as variation in the size and weight of prints, make it impractical to give firm rules for the washing time required. Length of washing time should be determined when the equipment is first placed in

operation under a given set of conditions; use the potassium permanganate test for the elimination of hypo. Recheck whenever the washer is used under different conditions. Repeated checking of performance in this manner will allow the operator to determine the time required for complete washing of various quantities, sizes, and weights of prints at a given water temperature and rate of water flow.

c. Removing prints.

(1) Turn off the power switch to the motor.

(2) Raise the cylinder by pressing down on the foot pedal until it is held by the pedal lock.

(3) Rotate the cylinder by hand until the index pin locks the cylinder in position.

(4) Release the door locks and open the door. Remove the prints and place them on the door to drain.

d. Shutting down washer.

(1) Remove all prints from the washer (c above).

(2) Turn off the shut-off valve (figure 3-2).

(3) Open the drain valve (figure 3-2) to drain the tank.

(4) Wipe the tank and cylinder with a clean dry cloth.

EXERCISE

2. What is the sole purpose for the foot pedal on the washer?

ANS: _____

3. To insure that the prints to be washed do not stick together in the wash, how should you place them into the washer?

ANS: _____

3-8 Purpose and Use of Equipment Performance Checklist

The equipment performance checklist (para 3-9) is used to determine whether Washer EK-1 is functioning properly. The checklist gives the item to be checked, the normal indication of correct operation, and the corrective measures that the operator can take. Check items 1 through 6 before starting, items 7 and 8 when starting, and items 9, 10, and 11 when stopping.

a. Action or condition. The information given under the Action or Condition column represents, in the case of some items, the control settings at which the item is to be checked. In other items the information represents the action that must be taken to check the normal indication given in the column bearing the title Normal Indication.

b. Normal indication. The normal indications listed include the visible and audible signs that the operator will perceive when he checks the items. If the indications in the equipment operation are not normal, the operator should apply the recommended corrective measures.

c. Corrective measures. The corrective measures listed are those that the operator can make without turning the equipment in for repairs. If the equipment will not operate or if the recommended corrective measures do not yield the desired results, turn the equipment in for repair by technical service personnel.

3-9 Equipment Performance Checklist

Item No.	Item	Action or Condition	Normal Indication	Corrective Measure
1	Power cord	Connects washer to an external power source	Power cord fits securely in source receptacle	Check power source, power cord, and repair or re-place.
2	ON-OFF switch	Power is on when switch is ON	Motor should start. Cylinder should revolve toward the operator.	Check wiring and motor. If cylinder revolves backward, reverse its direction by interchanging the leads to the starting winding of the motor.
3	Foot pedal	Raises and lowers cylinder into the tank	Cylinder should rise or descend without friction. Pedal lock should hold cylinder in place when raised.	Check foot pedal mechanism. Replace damaged or worn parts.
4	Cylinder	Turns freely when raised	Should be turned by hand until doors are on top and the index pin on the cylinder holds the cylinder in place.	Check index pin. Check cylinder shafts and rubber bearings.
5	Door locks	Releases easily	Should work smoothly so door can be opened or closed.	Check door locks for damage or broken parts.
6	Shut-off valve	Works easily	Should open to permit intake of water. Should close to shut off water supply.	Check valve for damage or broken parts.

Item No.	Item	Action or Condition	Normal Indication	Corrective Measure
S T A R T	7 ON-OFF switch	Starts and stops motor when turned ON or OFF	Motor starts and cylinder turns when switch is turned to ON	Check wiring and motor.
	8 Cylinder	Raises or descends easily when foot pedal is pushed down or released	Cylinder is lowered into tank when foot pedal is released	Check foot pedal mechanism for possible damage.
S T O P	9 ON-OFF switch	Starts and stops motor when turned ON or OFF	Motor stops and cylinder stops turning when switch is turned to OFF	Check wiring or motor. Remove power cord from receptacle.
	10 Cylinder	Rises or descends easily when foot pedal is pushed down or released	Push down on foot pedal until it locks; cylinder rises. Door is on top. Door unlocks so that prints can be removed.	Check foot pedal mechanism for damage.
11	Drain valve	Opens and closes easily	Tank empties when valve is open	Check drain valve for damage. Replace parts.

SECTION 2

ORGANIZATIONAL TOOLS, EQUIPMENT, AND LUBRICANTS

3-10 Tools and Equipment

No tools or equipment are issued for use with the Washer EK-1; however, the common tools, such as screw drivers and wrenches, which are required for maintenance services, are provided in Tool Equipment TK-24/GF. This tool kit contains general tools for repair of photographic equipment.

3-11 General Lubrication (figure 3-3)

Apply two or three drops of oil (OE-30) to the motor, pulley stud, and lift lever once every month. Apply oil (OE-30) to the bearing surfaces of the pulley stud and lift lever. The motor has two oil cups for application; the pulley stud has a single oil fitting.

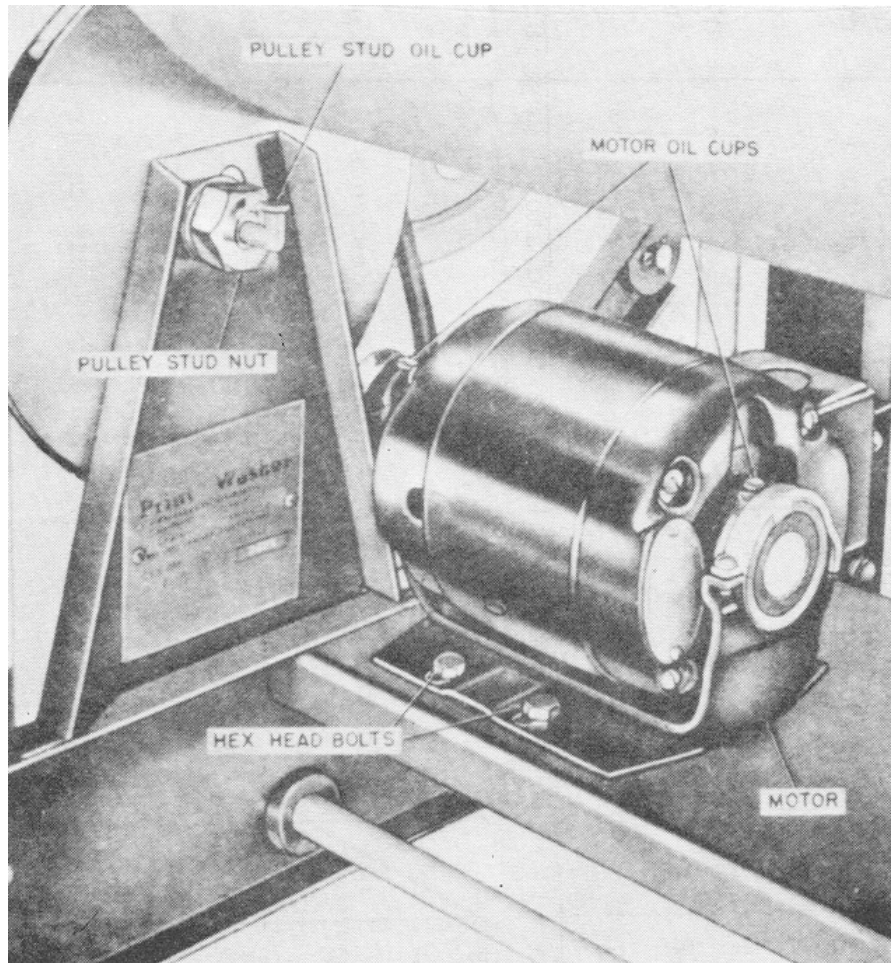

FIGURE 3-3. Motor and Pulleys (motor cover removed).

3-12 Stuffing Box Lubrication (figure 3-4)

Every three months, lubricate the stuffing box as follows:

- a. Lift up and pull out the end panel on the left side of the washer.
 - b. Remove the drive pulley by unscrewing one square-head setscrew in the pulley.
 - c. Unscrew the stuffing box cap clockwise; the cap has left-hand threads.
 - d. Pull off the stuffing box gland.
 - e. Apply several drops of oil (OE-30) to the packing.
- NOTE: Do not overlubricate. Wipe off all excess oil. Never pack the stuffing box with grease.
- f. Place the stuffing box gland on the roller shaft and screw the stuffing box cap into place (left-hand threads). Tighten the cap and then back it off one-half turn on adjustment.
 - g. Fasten the drive pulley to roller shaft with the squarehead setscrew.
 - h. Hang the end panel between the legs on the left side of the washer.

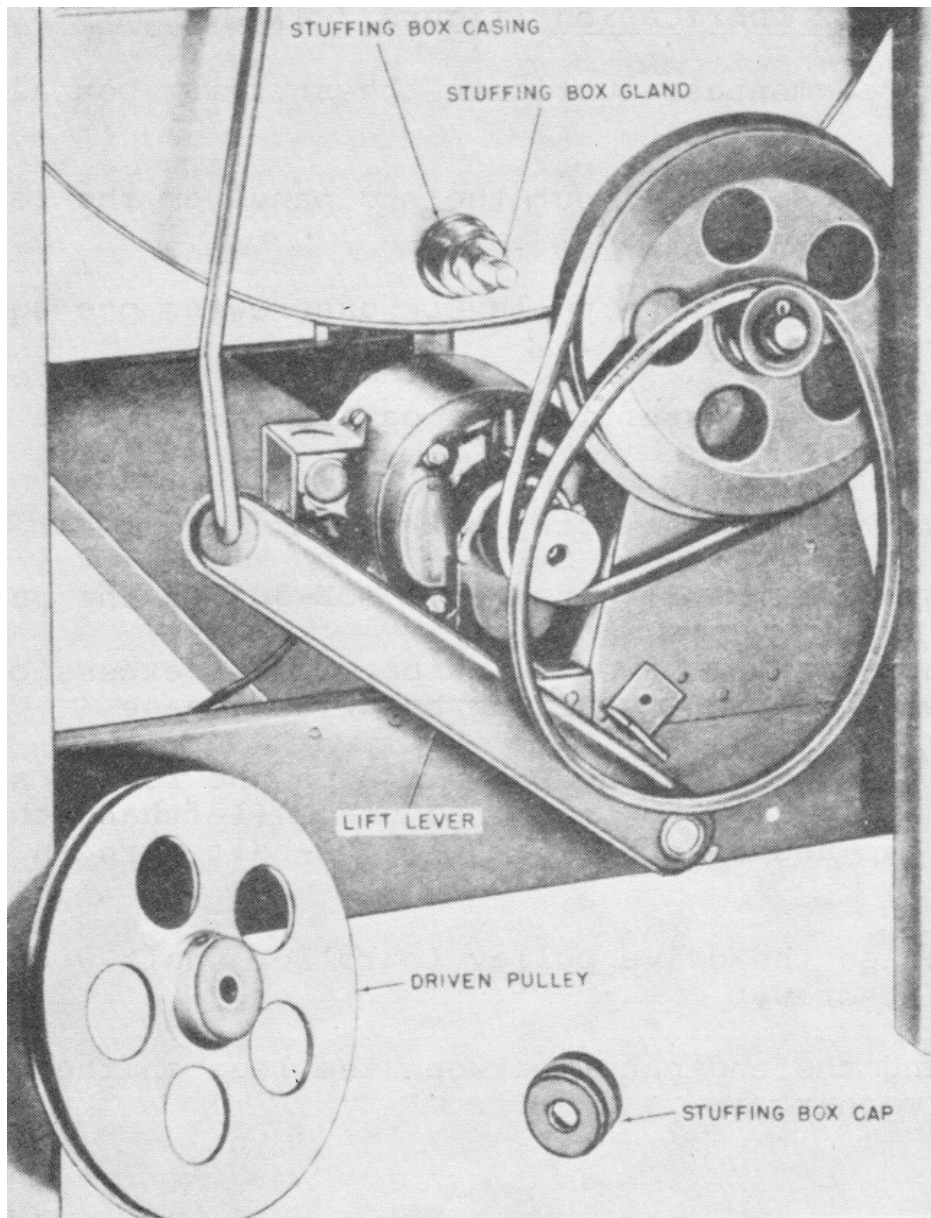

FIGURE 3-4. Stuffing box (end panel removed).

EXERCISE

4. What grade of lubricant oil must you use when lubricating the Washer EK-1? (circle answer)

a. 10W30

c. AG-60

b. OE-30

d. 40W

5. Where do you apply the lubricant when lubricating the washer, and how much?

ANS: _____

SECTION 3

PREVENTIVE MAINTENANCE SERVICE

3-13 Meaning and Importance

Preventive maintenance means making systematic checks and adjustments at regular intervals to keep equipment operating at top efficiency. It is not the same as troubleshooting and repair. The purpose of preventive maintenance is to prevent breakdowns and, therefore, the need for repair. The purpose of troubleshooting and repair is to locate and correct existing defects. The importance of preventive maintenance cannot be overemphasized. Failure or inefficient operation of one piece of equipment may cause the failure of the entire washer operation. It is vitally important, therefore, that operators properly maintain their equipment.

3-14 Preventive Maintenance Procedures

Most of the parts of Washer EK-1 require routine preventive maintenance. Because maintenance technique cannot be applied indiscriminately, definite and specific instructions are needed. Paragraphs 3-16 through 3-21 contain specific instructions for the general maintenance of the equipment and serve as a guide for organizational maintenance personnel.

3-15 General Inspection

To insure efficient and trouble-free performance of all operating parts, inspect, lubricate, and check Washer EK-1 for cleanliness at regular intervals. Avoid the use of unauthorized cleaning substitutes and of improvised implements of inspection and correction.

3-16 Frequency of Inspection

The preventive maintenance checklist (para 3-20) is a summary of the basic maintenance operations that are necessary and the intervals at which they should occur. Routine before-operational and after-operational inspection of Washer EK-1 should become habitual with the operator. A check of the motor and the cylinder driving mechanism should be made while the washer is in motion. Cleanliness of the washer is essential.

3-17 Cleaning

Every three days, the cylinder must be lifted from the tank for thorough cleaning. Simply lift the cylinder straight up and out of the tank. Flush out the tank to remove iron scale and slivers. See that the supply line is free of scale and foreign material. Then lower the cylinder onto the wooden bearings in the lift channels. Repeat the flushing.

3-18 Chemical Deposits, General

Once a week, wash the cylinder and the inside of the tank with a clean cloth, saturated with soap solution. Swab off any chemical deposits; rub vigorously if necessary. Then flush out the tank and cylinder.

3-19 Heavy Chemical Deposits

Where deposits of iron, rust, and other impurities have become heavy, special solutions must be used for removal. A 10-percent solution of sodium nitrate sprinkled with whiting compound may be used as a cleaner. On unpainted stainless steel surfaces, a 2- to 5-percent solution of oxalic acid should be used. Moisten a clean cloth with solution and rub vigorously over contaminated areas. If necessary, use a fiber brush to scrub the surface. Never use a wire brush or steel wool to clean the cylinder or tank. The tank and cylinder should be washed with one of these solutions every three months as a preventive maintenance service. Never use oxalic acid solution on painted surfaces because it will remove the paint.

3-20 Preventive Maintenance Checklist

Item No.	What to check	When to check	What to do
1	Cylinder, tank and frame	After operation	Dry with a clean, dry cloth.
2	Cylinder and tank	Every three days	Clean as directed in paragraph 3-17.
3	Cylinder and tank	Weekly	Swab off chemical deposits (para 3-18).
4	Cylinder and tank	Every three months	Wash and scrub (para 3-19).
5	Pulley belts	Monthly	Inspect for slipping and proper tension. Examine for wear and damage.
6	Tank and stuffing box	Monthly	Examine for leakage at the stuffing box.
7	Drain valve	Monthly	Examine for leakage.

3-21 General Troubleshooting

The equipment performance checklist (para 3-9) and the preventive maintenance checklist (para 3-20) contains the various visual and operational indications of normal performance while Washer EK-1 is in use. The corrective measures recommended in the equipment performance checklist relate ONLY to minor failures of equipment which can be remedied by a simple adjustment of parts which are otherwise unimpaired.

3-22 Maintenance Forms and Requests

Refer to TM 38-750 w/c 2 for appropriate forms and maintenance service.

EXERCISE

6. What is the main purpose of preventive maintenance?

ANS: _____

7. Under normal use, how often must you clean the cylinder and the tank for iron scale and slivers?

- a. Every five days.
- b. Once a week.
- c. Every three days.
- d. As often as needed.

8. Which of the following listed items should NOT be used for cleaning of the EK-1 Washer?

- a. 2- to 5-percent oxalic acid
- b. Fiber brush
- c. Steel wool and wire brush
- d. All of the above.

SECTION 4

PHOTOGRAPHIC FILM DRIER EL-4(1)

3-23 Scope

This section contains information on the operation and operator's preventive maintenance.

3-24 Purpose and Use

Photographic Film Drier EL-4(1) (figure 3-5) is a thermostatically controlled metal cabinet that dries roll and sheet (cut) photographic film. It is used in a film laboratory and is located as close as possible to the processing equipment.

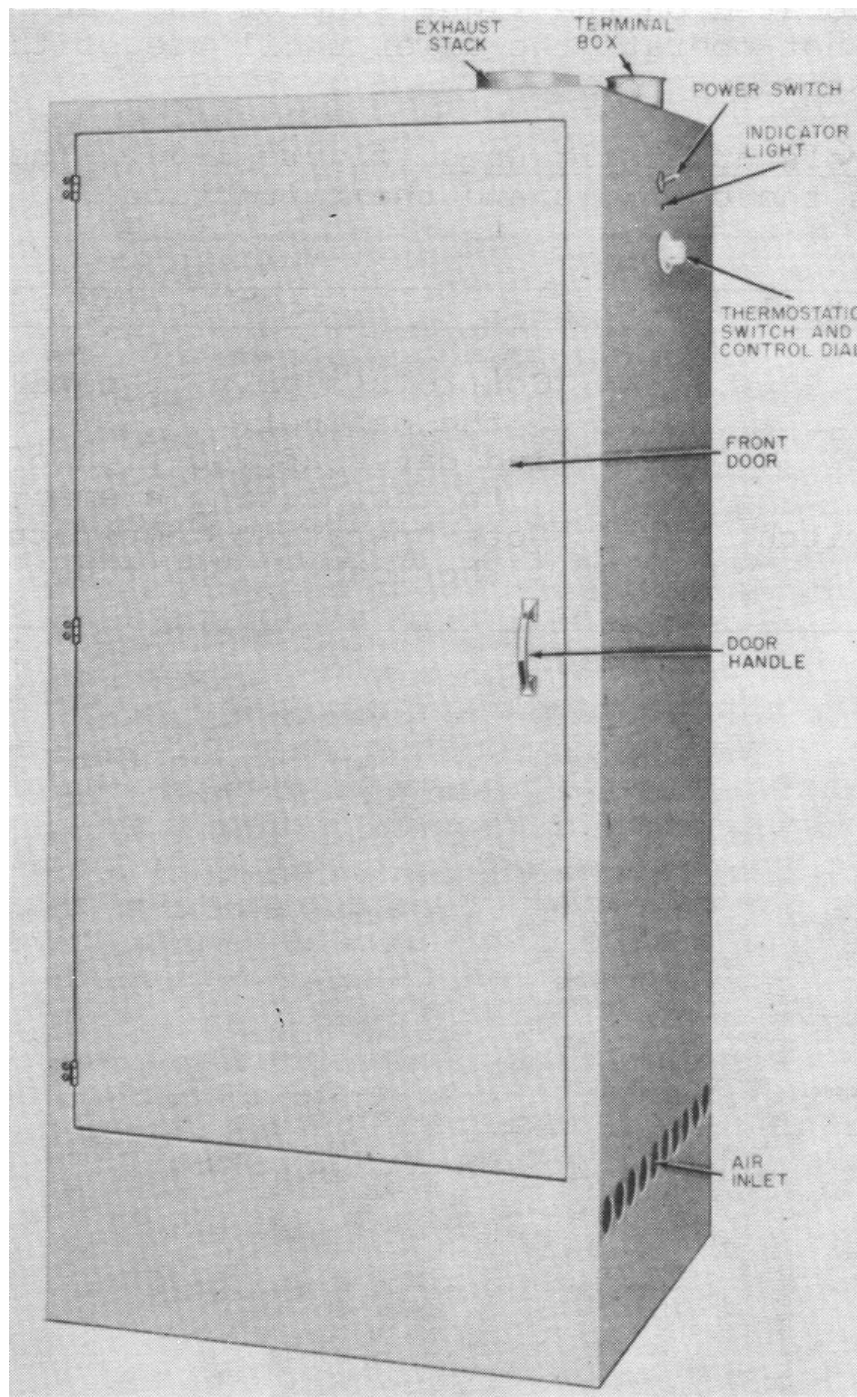

FIGURE 3-5. Front view of cabinet of Photographic Film Drier EL-4(1).

3-25 Controls

a. General. All controls provided for operation of the drier are located on the right side of the cabinet (figure 3-5). Do not operate the drier until use of these controls is understood.

b. Controls and their uses (figure 3-6). The following chart lists the controls and their functions.

Control	Function
POWER SWITCH	Controls supply of power to the cabinet.
Indicator light	Indicates application of voltage to the heating element.
Thermostatic-switch control dial	Sets operating temperature of thermostatic switch.

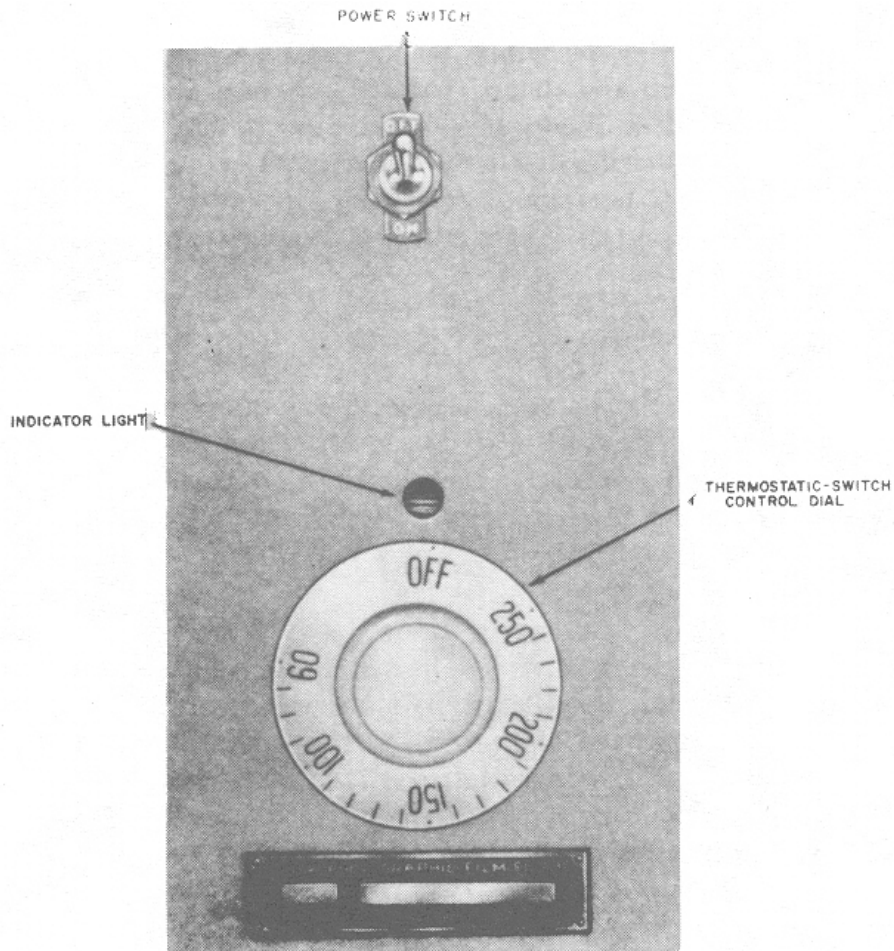

FIGURE 3-6. Operating controls.

3-26 Preparation for Drying Cut Film

a. Lift the two removable trays (figure 3-7) from the cabinet.

b. Position the four side-panel brackets (on which the trays will rest) at heights that will accommodate the cut film to be dried. The brackets have clips to engage the vent holes on the side panels. Do not position the brackets too close to each other; allow sufficient room for thorough air circulation and even drying of all the film.

c. Set the removable trays on the brackets.

d. Hook the cut film hangers onto the notched rails on the underside of the removable trays (figure 3-7). Be sure that each hanger is set into a notch. In this position, the air flow hits the edges of the film and is across, not against, the face of the film.

e. When the cabinet is fully loaded, close the door.

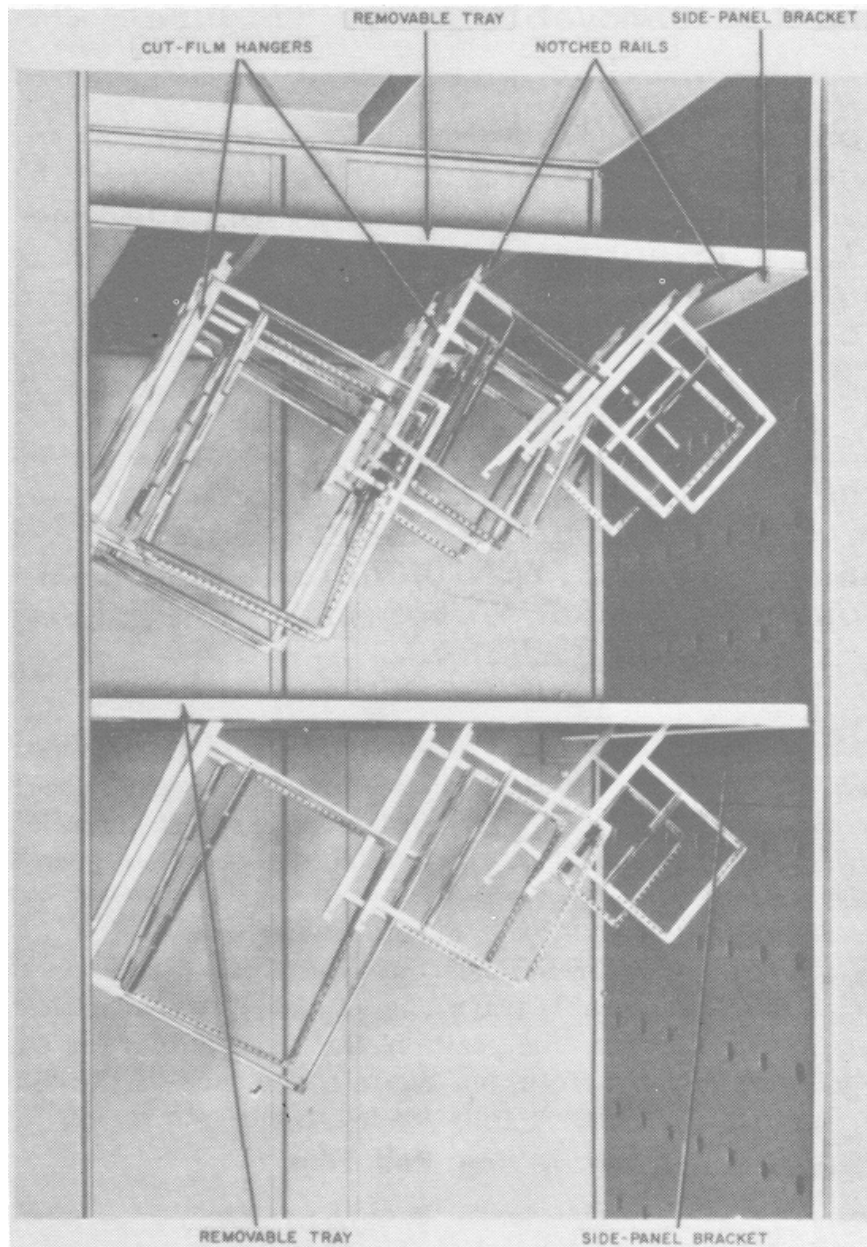

FIGURE 3-7. Cut film hangers suspended from notched rails.

3-27 Preparation for Drying Roll Film

- a. Lift the removable trays from the cabinet.
- b. Hook a side-panel bracket into the row of vent holes (next to the top) on each side panel (figure 3-8). Note that the brackets will not fit into the top rows of holes.
- c. Slide the film clips onto the film-clip rods; place a maximum of ten clips on each of the five film-clip rods. Space the film clips evenly on each rod.

d. Set the film-clip rods on the top of the side-panel brackets; space the rods evenly from the front to the rear of the cabinet. (The L-shaped ends will keep the rods from rolling.) Be sure that the air from the vents in the side panel hits the edges of the film and is across, not against, the face of the film.

e. Attach weights (figure 3-8) to the lower ends of the film strips to be sure that they hang straight and do not curl up when dried.

f. Close the door carefully, to avoid loosening any dust there might be on the inside of the drying cabinet.

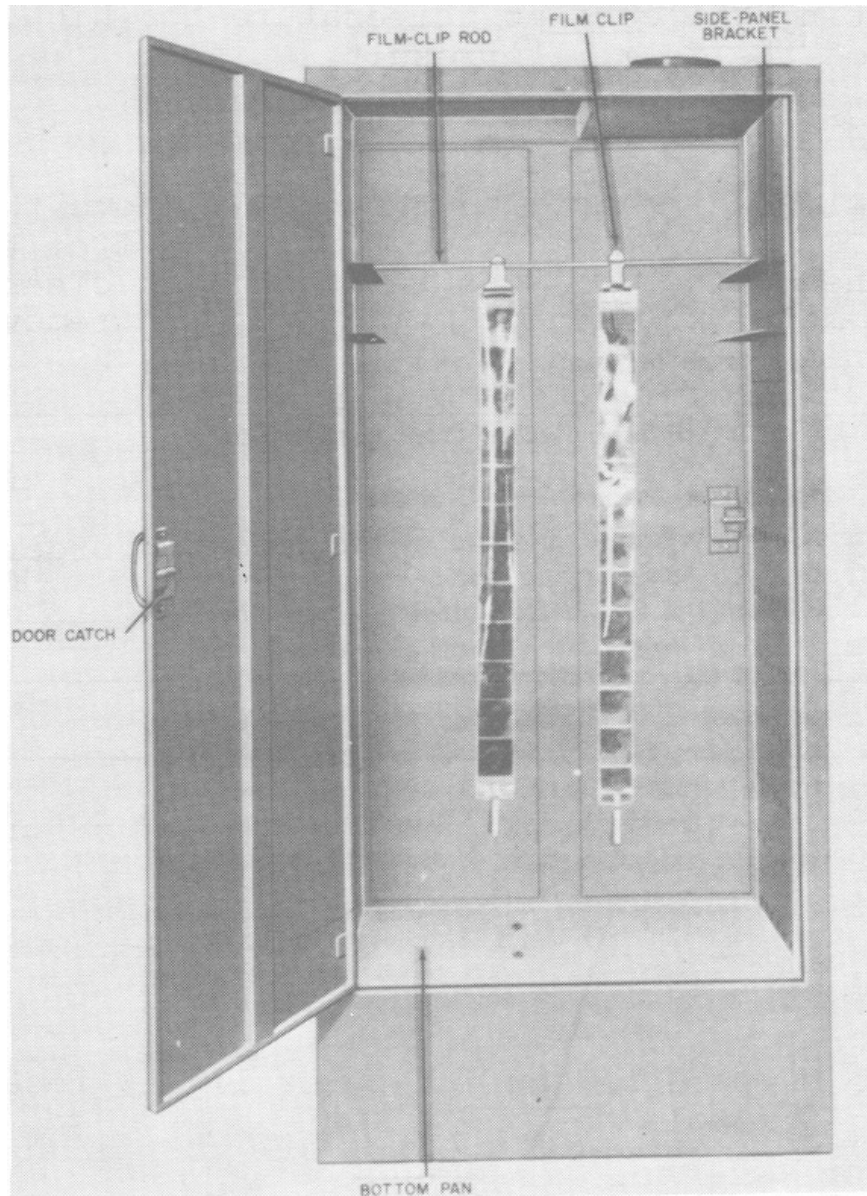

FIGURE 3-8. Roll film hanging from film clips.

3-28 Drying Procedure

a. Move the power switch (figures 3-5 and 3-6) to the ON position. The sounds of the motor and fan should be heard.

b. Set the thermostatic-switch control dial at 100° F. The indicator light should glow.

c. Normal drying time with a full load of film in the cabinet is approximately 45 minutes, with room temperature at 65° to 75° F, and the relative humidity at 40 to 50 percent.

CAUTION: Do not attempt to decrease drying time by setting the cabinet temperature too high. Curling of the film will result.

3-29 Stopping Drier

When the film has been dried thoroughly, move the power switch to the OFF position and remove the film from the cabinet. Inspect the cabinet to be sure that it is clean and dry and that no moisture has accumulated on the removable trays.

EXERCISE

9. When drying roll film, what must you do in order to prevent the film from curling up, when drying?

ANS: _____

10. What is the recommended drying temperature for drying film? (circle one)

- | | |
|-----------|-----------|
| a. 60° F | c. 100° F |
| b. 150° F | d. 200° F |

11. What is the purpose of the indicator light, located by the operating controls?

ANS: _____

SECTION 5

FIRST ECHELON (OPERATOR) MAINTENANCE

3-30 Operator's Maintenance

The photographic laboratory technician, the operator of the drier, is responsible for daily, weekly, and 200-hour preventive maintenance routines. Corrective maintenance at this level requires replacement of air filter only. Necessary repairs or replacement, noted during inspection and requiring correction by a higher echelon, will be indicated by the operator on the DA Form 2404.

3-31 Tools and Materials Required

The tools and materials required by the operator for maintaining the drier are listed below.

ITEM	USED TO
Chamois	Clean the cabinet.
Cleaning brush, 1-inch dia	Remove dust from corners and from motor and fan.
Cleaning Compound (Fed Stock No. 7930-395-9542)	Remove stubborn dirt and grime.
Common hand tools including: Screwdrivers TL-358/U and TL-360/U Wrench TL-111 Pliers TL-13-A Knife TL-29	Tighten cabinet hardware and motor and fan mounting.
Lint-free cloth	Remove dust from drier.
Sponge	Wash the cabinet.
Oil, Engine, Heavy Duty (OE-10)	Lubricate the motor.

3-32 Preventive Maintenance Services

Procedures for routine preventive maintenance are explained in para 3-34. Make a careful inspection of the equipment before and after each time it is used. It is essential to keep the drier clean at all times. Abrasive particles in dust may settle on film and cause scratches.

a. Dust the interior and exterior of the cabinet. Use a dry, clean, lint-free cloth.

b. Clean the interior and exterior of the cabinet with a sponge and warm soap solution to remove all traces of accumulated dust or dirt. Rinse and wipe thoroughly with a chamois.

c. For stubborn dirt or other foreign substances, use cleaning compound. Remove cleaning compound residue with the sponge and warm water and soap solution. Remove the soap solution with the chamois and clear water.

d. Remove corrosion with cleaning compound and #0000 sandpaper. Remove cleaning compound residue as described in c above.

CAUTION: Prolonged breathing of cleaning compound fumes is dangerous. Be sure that adequate ventilation is provided. Cleaning compound is flammable; DO NOT use it near a flame.

e. Clean the air filter as follows:

(1) Remove the two screws that hold the bottom pan to the metal baffle (figure 3-9).

(2) Lift the bottom pan and remove it from the cabinet.

(3) Lift the air filter up and out of the bottom of the cabinet.

(4) Tap the dirt out of the air filter. If a vacuum cleaner is available, use the suction to remove the dirt.

(5) Return the air filter; be sure that the dirty side faces the air inlet holes (figure 3-5).

(6) Replace the bottom pan.

NOTE: Discard the air filter if cleaning attempts are unsuccessful.

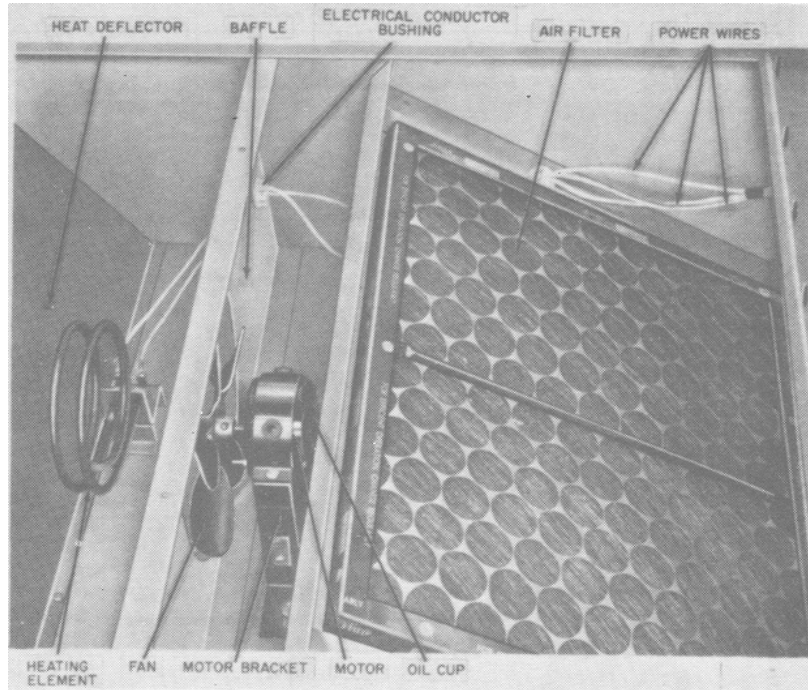

FIGURE 3-9. Air filter, motor, fan, and heating element installed.

3-33 Lubrication

The motor is the only component that requires lubrication. Two or three drops of oil (OE-10) in the oil cup on each end of the motor (figure 3-9) at six-month intervals, will provide adequate lubrication for the motor bearings.

3-34 Preventive Maintenance Procedures

a. Weekly.

What to check	How to check	Precautions
Completeness of equipment.	Be sure all components are on hand.	
Inspect for moisture, fungi, rust, grease, oil, and dust.	Examine equipment thoroughly. Clean as necessary (para 3-32).	
Power cord.	Inspect for dirt, moisture, cracks, breaks, oil, grease, or deterioration.	Disconnect cord from power source before handling.
Air filter.	Remove bottom pan (fig. 3-8) and examine filter (fig. 3-9).	Replace the filter if it is still excessively dirty after cleaning.

b. Every 200 hours.

What to check	How to check	Precautions
Perform weekly preventive maintenance service (a above).		
Motor and fan.	Remove the bottom pan (fig. 3-8). Be sure that the motor and fan are securely attached and are clean.	Disconnect the power cord while inspecting and servicing the drier.
Heating element.	Be sure that the heating element (fig. 3-9) and electrical connections are securely attached and are clean.	
Power wires.	Inspect the wires (fig. 3-10 and 3-9) for fraying, broken insulation, dirt, or grease. Clean as necessary.	
All screws, nuts, and bolts in the drier.	Tighten as necessary.	

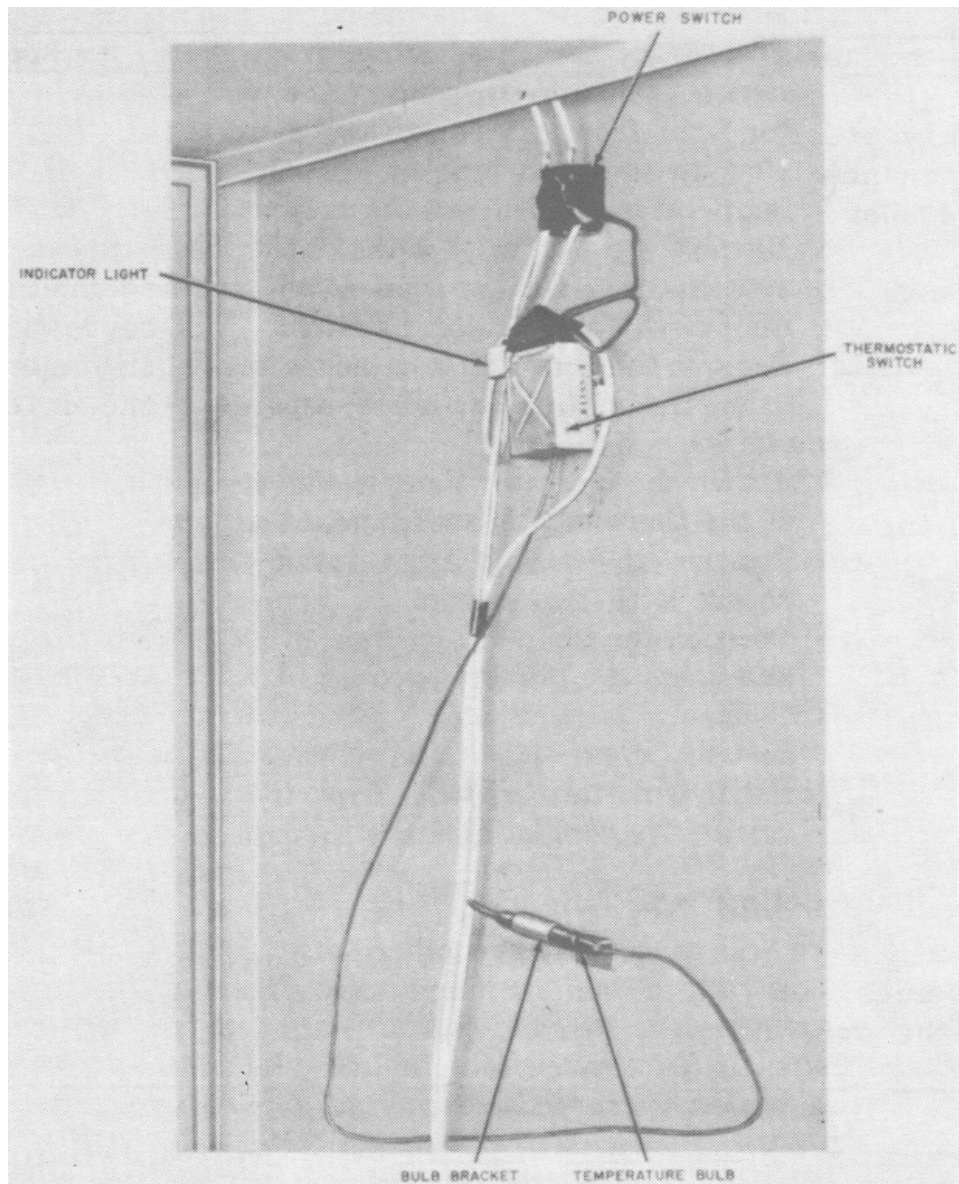

FIGURE 3-10. Power and thermostatic switches; indicator light and associated parts and wiring.

EXERCISE

12. The scheduled operator's preventive maintenance is scheduled at the following interval:

- a. _____
- b. _____
- c. _____

13. What precautions must you take when you are using cleaning compound for cleaning the film drier?

ANS: _____

14. How often and how much oil should be used when lubricating the electric motor?

ANS: _____

SECTION 6

DRIER, PHOTOGRAPHIC PRINT EL-5(1)

3-35 Scope

a. This section describes Drier, Photographic Print EL-5(1) and covers the operation, and operator's maintenance. It includes instructions for operation under normal conditions and instructions for cleaning and inspecting the equipment.

b. Throughout this section, Drier, Photographic Print EL-5(1) is referred to as drier.

3-36 Purpose and Use

a. Purpose. The drier is a complete self-contained, electrically operated, portable unit capable of quickly and continuously drying various weights and types of photographic print paper (figure 3-11).

b. Use. The drier is intended for use in a photographic laboratory for drying glossy and matte prints.

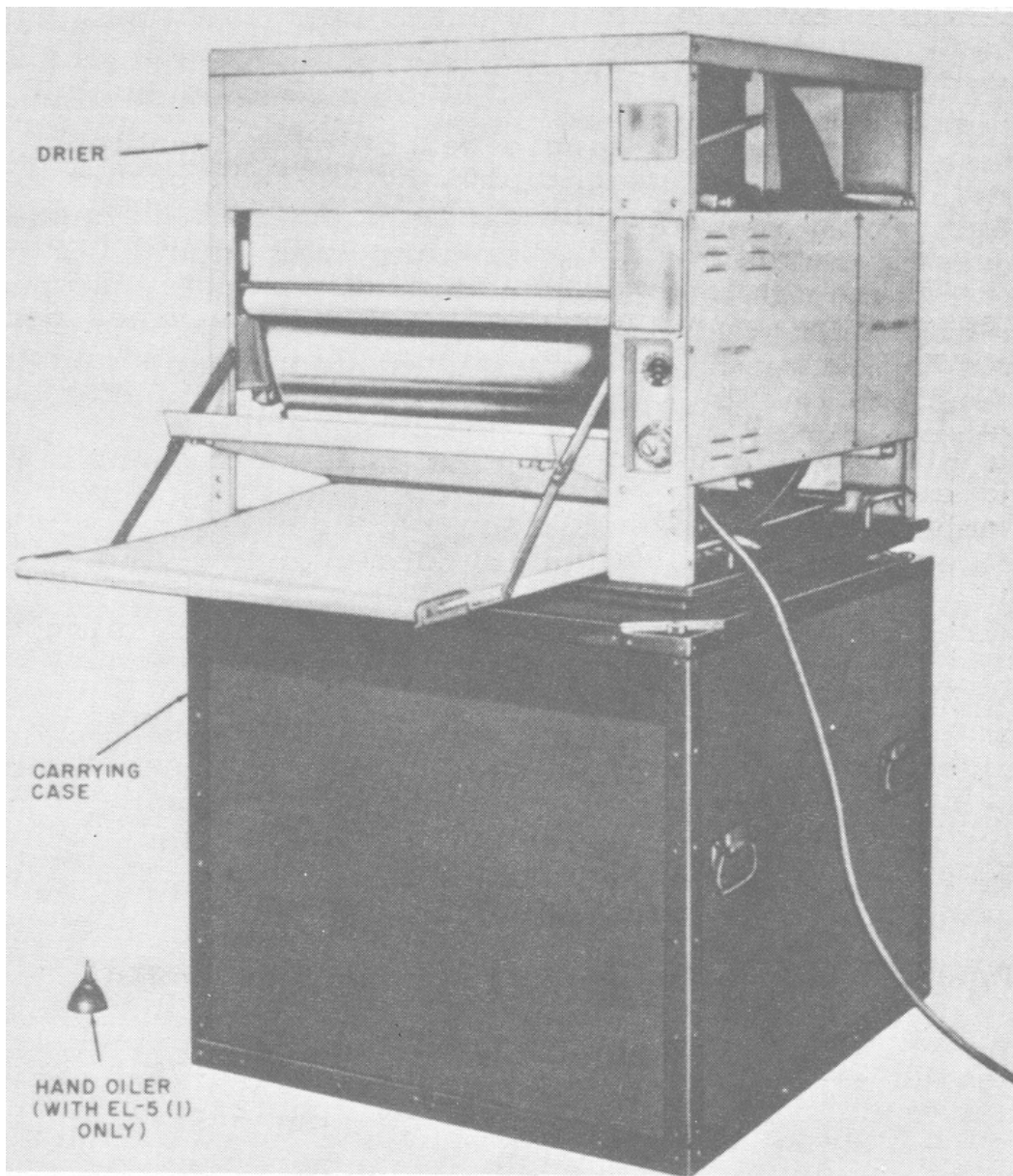

FIGURE 3-11. Drier, Photographic Print EL-5(1).

3-37 Technical Characteristics

Type-----Electric, rotating drum.

Capacity-----170 single-weight or 85 double-weight,
10- by 10-inch prints per hour.

Apron width-----25 inches.

Apron speed-----Adjustable from 9 to 16 inches per
minute.

Temperature
range-----0° to 230° F.

Heating elements:
Number-----4
Power rating-----2,500 watts total.

Voltage
requirements-----115 volts, 50 to 60 cycles, single-
phase ac.

Current
requirements-----25 amp.

Power
consumption-----2,875 watts.

Motor:
Type-----Shaded pole-type with integral speed
reducer.

Rating-----1/18 hp at 5,000 rpm (PH-75-B).
1/20 hp at 5,000 rpm (EL-5(1)).

Reduction ratio of
motor speed to
apron speed-----1,080 to 1.

3-38 Description

The drier includes a polished steel drum with a heater assembly, a flat belt (apron), a motor, a drive roller, a squeegee roller, a take-up roller, a print tray and a feed table. The operating controls (figure 3-12) are located on the front and right sides of the drier. Frame handles are

mounted on the frame to facilitate handling of the drier during unpacking and movement of the drier. The carrying case is constructed of heavy marine plywood sections secured and supported by welded steel angles and corner braces. The carrying case is also used as a base for the drier during operation.

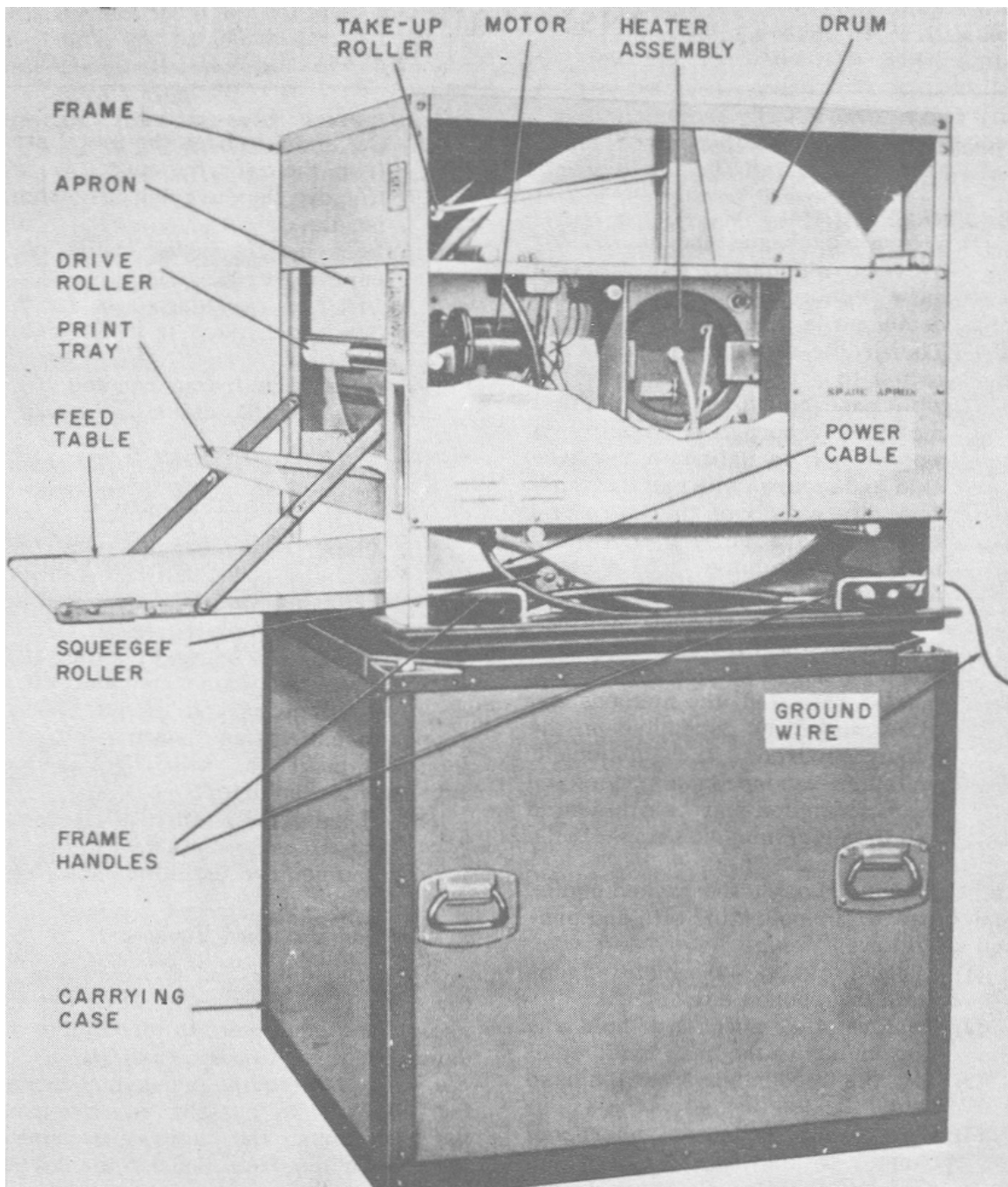

FIGURE 3-12. Front and right-hand side of drier with cutaway view showing heater assembly and motor.

SECTION 7

OPERATION INSTRUCTIONS

3-39 Controls, Adjustments, and Indicators (figure 3-13)

The controls, adjustments, indicators, and their functions are listed in the following chart:

Control, adjustment, or indicator	Function
Circuit breaker ^a	Protects electrical circuits from overload.
MOTOR switch	Supplies power to the motor.
HEATER switch	Supplies power to the thermostat control and heater assembly.
Thermostat control	In OFF position, disconnects power from part of the heater assembly. In any other position, regulates the temperature of the drum by controlling power to part of the heater assembly.
Speed control	Adjusts apron speed.
Glowlamp	Glows to indicate that thermostat is supplying power to part of the heater assembly.
Squeegee lever	Positions the squeegee roller in relation to the drum: In the GLOSSY PRINTS position, the squeegee roller is held tightly against the drum. In the MATTE PRINTS position, the squeegee roller is held so that a small space exists between it and the drum.
Apron adjustment screw (fig. 3-15).	Adjusts lateral position of apron.

^aIn the EL-5(1), the circuit breaker is marked CIRCUIT BREAKER.

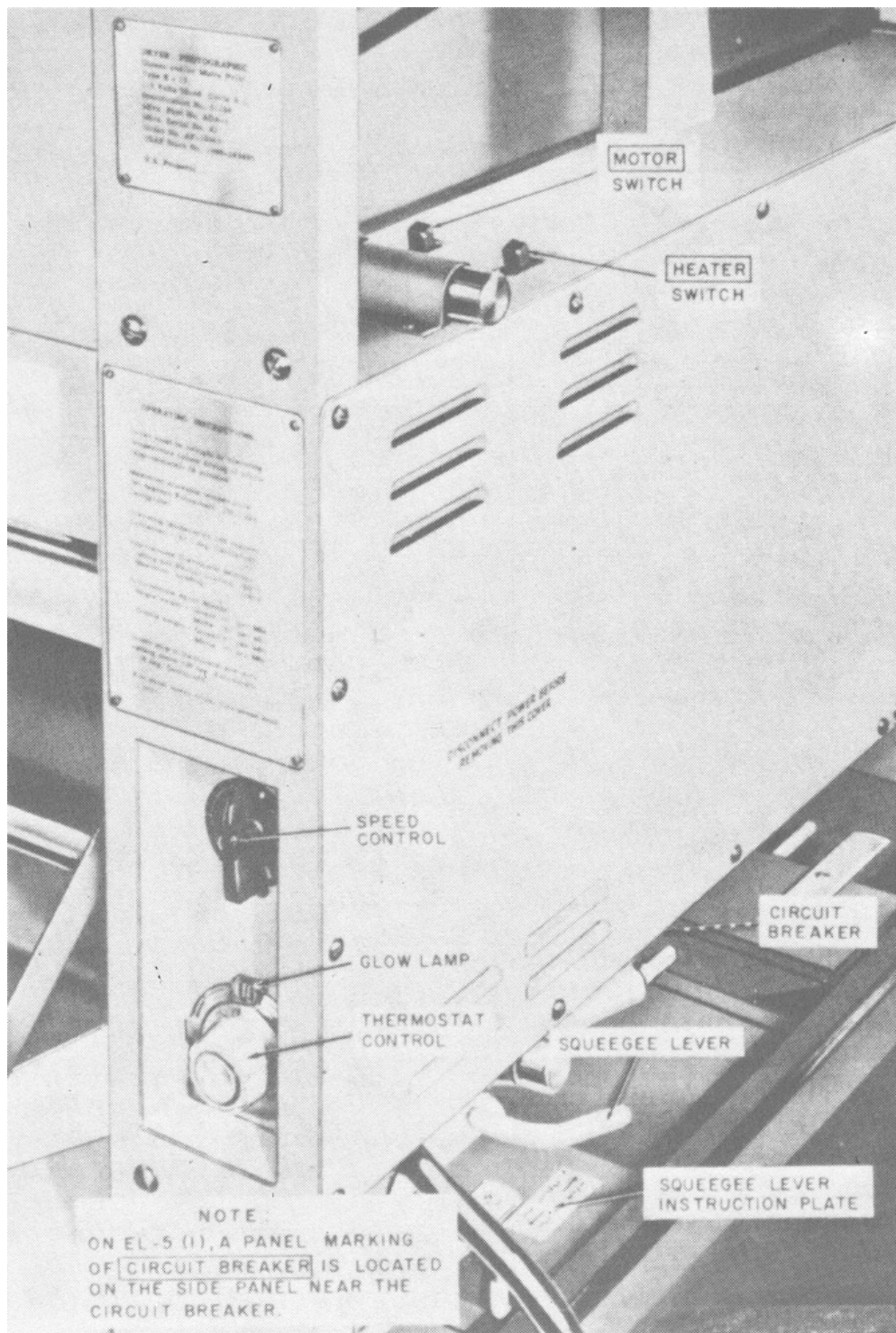

FIGURE 3-13. Controls and indicators.

EXERCISE

15. What is the maximum heating temperature on the EL-5(1) drier?
- a. 220° F
 - b. 185° F
 - c. 230° F
 - d. 195° F

16. What is the purpose of the circuit breaker?

ANS: _____

17. The two positions for the squeegee lever are _____
and _____.

3-40 Preliminary Operating Procedures

- a. Release the latch bolts (figure 3-14) and lower the feed table into operating position.
- b. Lower the print tray and engage its two latch bolts with the feed table links (figure 3-15).
- c. Remove all dust and dirt from the print tray with a clean, lint-free cloth.

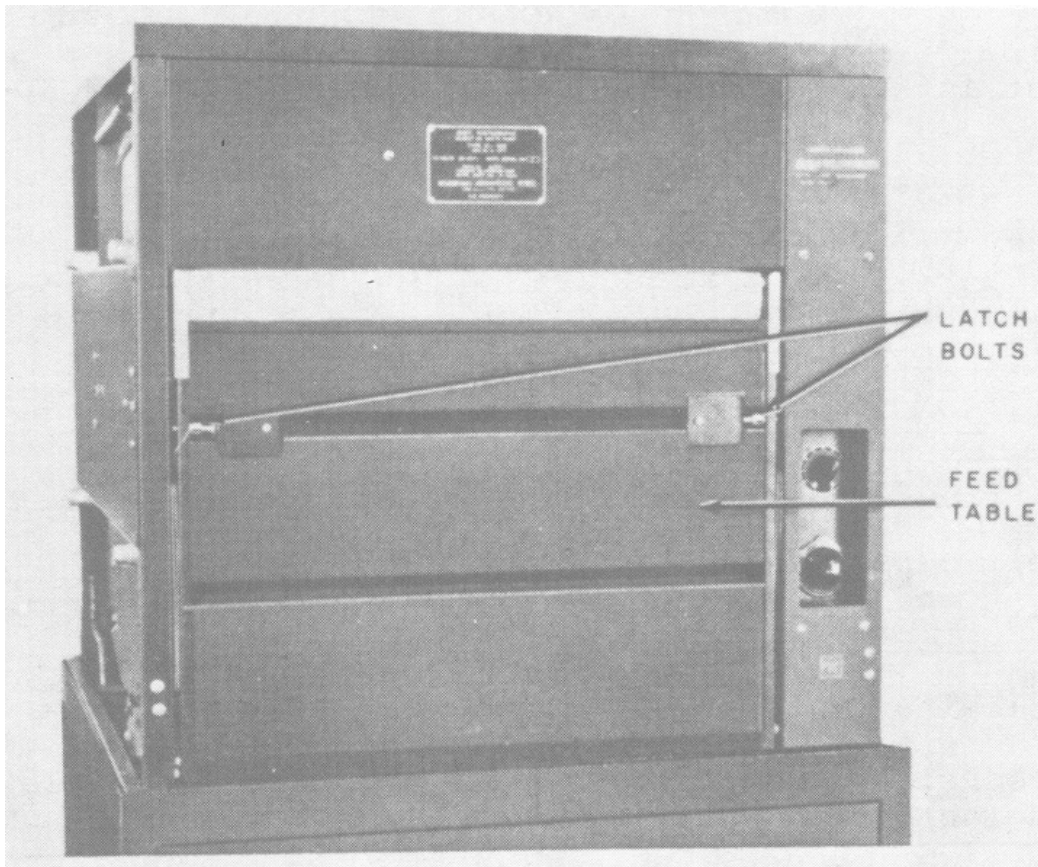

FIGURE 3-14. Feed table in locked-up position.

d. Place the squeegee lever (figure 3-13) in the MATTE PRINTS position, rotate the drum by hand, and carefully dust the surface of the drum with a clean, lint-free cloth.

e. Check to see if the drier is properly connected.

f. Operate the circuit breaker (figure 3-13) to the ON position.

g. Operate the MOTOR switch to the ON position.

h. Operate the HEATER switch to the ON position.

CAUTION: Do not turn the HEATER switch to the ON position unless the MOTOR switch is in the ON position.

i. Operate the speed control to cause the apron to move slowly.

j. Operate the thermostat control to the 220° F position and check to see that the glowlamp is lighted.

NOTE: The thermostat control has an internal safety stop at 230° F to prevent overheating the drum and damaging the equipment.

k. Allow 20 minutes for the drier to reach operating temperature. During this time, the apron travel should be adjusted [(1) below]. When the drier reaches the temperature preset on the thermostat control (i above), the glowlamp will go out.

1. Observe the apron travel. If the apron tends to run off to one side of the feed table and drum, adjust the lateral position of the apron as follows:

(1) Loosen the apron adjustment screw (figure 3-15).

(2) To cause the apron to track more to the left, move the screw and feed table extension slightly away from the drier.

(3) To cause the apron to move more to the right, move the screw and feed table extension slightly toward the drier.

(4) Tighten the apron adjustment screw.

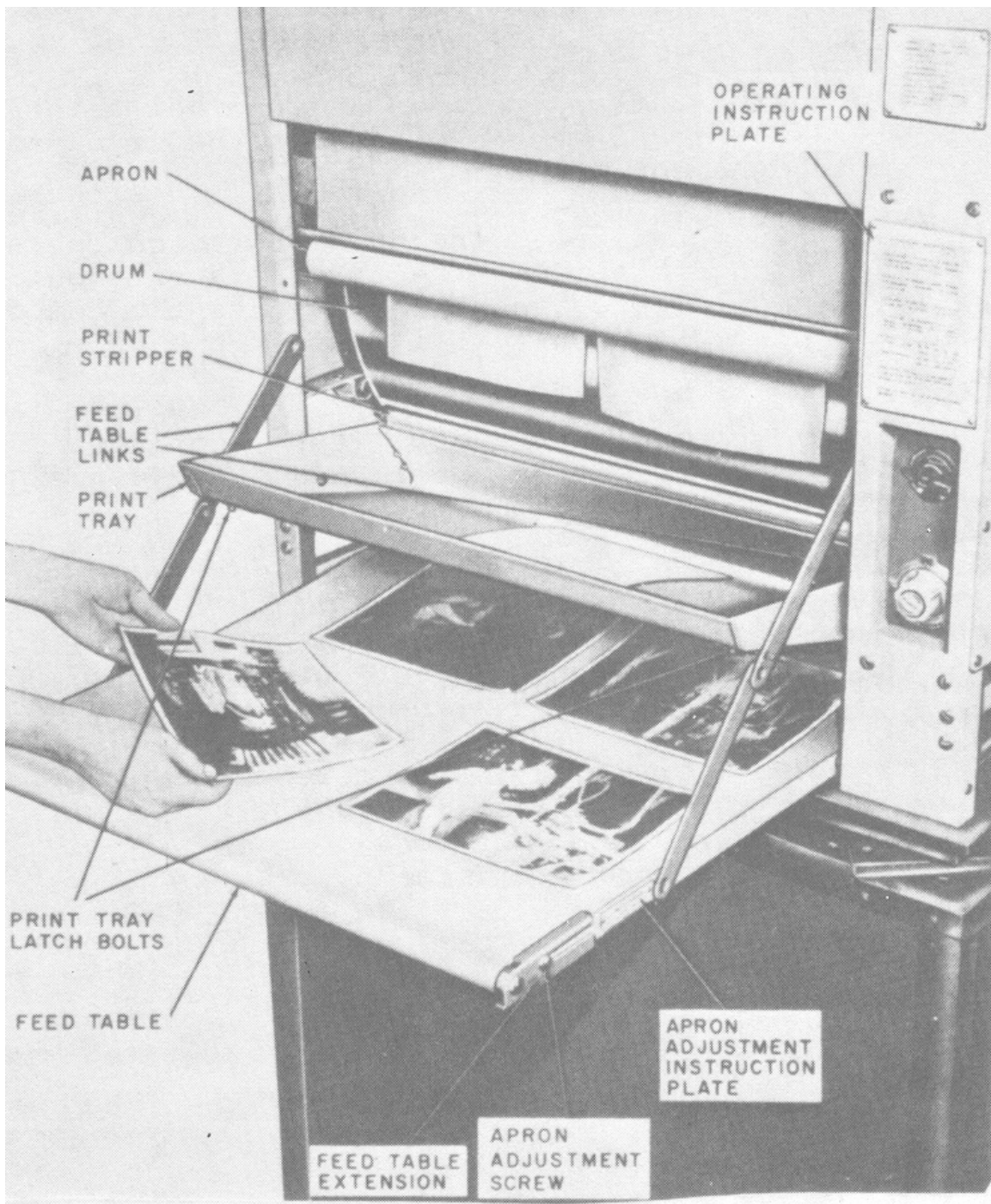

FIGURE 3-15. Feed table and print tray in operating position.

EXERCISE

18. How long should you let the drier warm up before drying print?
- a. 10 minutes
 - b. 15 minutes
 - c. 30 minutes
 - d. 20 minutes
19. You do not turn the _____ switch to the ON position unless the MOTOR switch is in the _____ position. (fill in the blanks)
-

3-41 Print Drying Procedures

Prints must be thoroughly washed before drying (TM 11-401). Drain all prints for several minutes, separate the glossy prints from the matte prints.

CAUTION: Do not allow the foreign material to collect on the drier at any time, particularly on the apron. Foreign material will be carried to the drum and mar the highly polished finish. Do not allow the print stripper cloth (figure 3-15) to fall between the drum and print tray.

a. Drying glossy prints.

- (1) Place the squeegee lever (figure 3-13) in GLOSSY PRINTS position.
- (2) Place the prints face (emulsion side) UP on the apron (figure 3-15) leaving approximately 1/2-inch distance between prints.
- (3) During operation, adjust the speed and thermostat controls (c below).

b. Drying matte prints.

- (1) Place the squeegee lever (figure 3-13) in the MATTE PRINTS position.
- (2) Place the prints face (emulsion side) DOWN on the apron (figure 3-15) leaving approximately 1/2-inch distance between prints.

(3) During operation, adjust the speed and thermostat controls (c below).

c. Adjusting speed and thermostat control (figure 3-13)

Exact operating conditions will vary with air temperature, relative humidity, paper weight, line voltage, and amount of water on the print when placed on the apron. If the drum is too hot, warping and poor glossing of the prints will result. If the drum is too cool, the prints will not be dry, and glossy prints will stick i n s t e a d of dropping into the print tray. Generally, the thermostat control setting will be correct and the apron speed must be adjusted until the prints are dry enough to fall off the drum into the print tray. Below is a table showing the approximate operating control settings.

Control	Setting
Thermostat:	
Idling and partial load.....	200°
Maximum load.....	220°
Speed:	
Single-weight, glossy.....	16 in./min
Single-weight, matte.....	18 in./min
Double-weight, glossy.....	8 in./min
Double-weight, matte.....	9 in./min

EXERCISE

20. When drying print and you have to change from one type to another, you must first change the position of the _____ .
(fill in blanks)

21. When placing prints to be dried on the apron, you should maintain at least how much distance between the prints?

- a. 1/4 inch
- b. 1/2 inch
- c. 3/4 inch
- d. 1 inch

3-42 Stopping Procedures

- a. Operate the thermostat control (figure 3-13) to the OFF position.
- b. Operate the HEATER switch to the OFF position.
- c. Allow the motor to run approximately 15 minutes to cool the drum and dry the apron.

CAUTION: Never leave the HEATER switch in the ON position when the drum is not rotating. This will result in scorching the apron.

- d. Operate the speed control to the maximum counterclockwise position.
 - e. Operate the MOTOR switch to the OFF position.
 - f. Operate the circuit breaker to the OFF position.
 - g. Unlock the print tray latch bolts from the feed table links (figure 3-15) and raise the print tray and feed table to the vertical flush position (figure 3-14).
 - h. Secure the feed table to the drier frame with the latch bolts.
-

SECTION 8

OPERATOR'S PREVENTIVE MAINTENANCE

3-43 Scope of Operator's Maintenance

The operator is responsible for daily and weekly preventive maintenance (para 3-44) and for performing the procedures given in the equipment performance checklist (para 3-45). Corrective maintenance at first echelon level does not require the replacement of any part of assembly. Deficiencies and repairs or replacements required must be noted by the operator and referred to higher echelon for correction.

3-44 Tools and Materials Required

a. A screwdriver is required to adjust the lateral position of the apron.

b. The following materials are required for preventive maintenance.

- (1) Lint-free cloth.
- (2) Cleaning compound (FSN 7930-395-9542).
- (3) Sponge (FSN 7920-243-6181).

3-45 Preventive Maintenance

a. Daily preventive maintenance. The following items must be checked daily.

- (1) External surfaces of components. Check for:
 - (a) Dust.
 - (b) Dirt.
 - (c) Finger marks.
 - (d) Moisture.
- (2) Check switches and controls for:
 - (a) Binding.

- (b) Scraping.
- (c) Excessive looseness.
- (d) Positive action.

b. Weekly preventive maintenance consists of:

(1) Inspecting belts for:

- (a) Stretched condition.
- (b) Worn.
- (c) Frayed.

(2) Inspecting exposed metal surfaces for:

- (a) Rust.
- (b) Corrosion.
- (c) Chipped paint.

c. The above given preventive maintenance items are to be performed when operator's preventive maintenance is being done both daily and weekly.

3-46 Equipment Performance Checklist

a. General. This checklist is used to systematically check equipment performance. All corrective measures that the operator can perform are given in the Corrective Measures column. If the action taken by the operator does not correct the fault, additional maintenance is required by higher echelon personnel. The operator should note on the DA FORM 2404 how the equipment performed and the corrective measures taken. Start at the beginning of the equipment performance checklist and follow each step in sequence to locate the trouble. However, if trouble is suspected in a particular area, check at that point first and continue the steps in the order listed.

b. Checklist. Operate the equipment (refer to figure 3-13 for location of controls and adjustments), as indicated in the checklist on the fold-out page.

Item No.	Item	Action	Normal Indications	Corrective Measures
P R E P A R A T O R Y				
1	Print tray and feed table.	Lower and lock in operating position (para 3-39a and b).	Feed table and print tray lower smoothly and the print tray locks securely.	Check for dirt or obstruction. Turn in equipment for higher echelon repair.
2	Squeegee lever.	Note pressure of squeegee roller (fig. 3-12) as follows: Place squeegee lever in GLOSSY PRINTS positions. Place squeegee lever in MATTE PRINTS position.	Squeegee roller exerts firm, even pressure on drum. Squeegee roller exerts little or no pressure on drum.	Turn in equipment for higher echelon repair. Turn in equipment for higher echelon repair.
3	Drum.	With squeegee lever in MATTE PRINTS position, turn drum by hand.	Drum rotates smoothly without binding.	Turn in equipment for higher echelon repair.
4	Power cable.	Connect to power source.		
S T A R T				
5	CIRCUIT BREAKER (Panel marked on EL-5(1) only.)	Operate to ON position.	Circuit breaker stays in ON position.	Reset the circuit breaker (fig. 3-13).
6	MOTOR switch.	Operate to ON position.	Apron and drum begin to move.	Check power source and cable connection.
7	HEATER switch.	Operate to ON position.	Apron and drum speed changes.	Turn in equipment for higher echelon repair.
8	Speed control.	Operate to mid-position.	Glowlamp glows for approximately 10	Turn in equipment for higher echelon repair.
9	Thermostat control.	Operate to 150° setting.		

			minutes, and then goes out.	
E Q U I P P E R E	10	Thermostat control.	Operate to a setting above 150°.	Turn in equipment for higher echelon repair.
	11	Speed control.	Operate to a setting Operate in the clockwise direction. Operate in the counterclockwise direction.	Turn in equipment for higher echelon repair. Turn in equipment for higher echelon repair. Turn in equipment for higher echelon repair.
S T O P	12	Thermostat control.	Operate to OFF position.	Turn in equipment for higher echelon repair.
	13	HEATER switch.	Operate to OFF position. Allow the motor to run until the drum is cool.	
	14	Speed control.	Operate to the maximum counterclockwise position.	Turn in equipment for higher echelon repair.
	15	MOTOR switch.	Operate to OFF position.	Turn in equipment for higher echelon repair.
	16	CIRCUIT BREAKER (Panel marked on EL-5(1) only.)	Operate to OFF position.	
	17	Power cable.	Disconnect from power source.	
	18	Print tray and feed table.	Raise and lock in vertical flush position.	Turn in equipment for higher echelon repair.

EXERCISE

22. The performance checklist is divided into various steps (sequence) to be performed. These steps are as follows:

- a. _____
- b. _____
- c. _____
- d. _____
- e. _____

23. When operating the thermostat control while set at above 150° F, what should the normal indication be?

ANS: _____

24. The squeegee lever is set in the GLOSSY PRINTS position, but the dried prints do NOT come off the dryer with a glossy print surface. What is the corrective measure indicated on the performance checklist?

ANS: _____

SUMMARY

You have just completed the third lesson on the operation and the operator's preventive maintenance on the photographic print washer, the photographic film drier, and the photographic print drier. The mere fact that you have completed this lesson does not make you an expert on the operation and maintenance of photographic finishing equipment. But it will help to assist you in your daily performance of your assignment. For more specifics on scheduled maintenance, you should check with your laboratory supervisor for any assistance you might need during your daily job performance.

EXERCISE SOLUTIONS

Lesson 3

1. 115-volt, 60-cycle ac, (para 3-2)
2. raising and lowering of the cylinder, (para 3-6)
3. one print at the time, (para 3-7)
4. b, (para 3-11)
5. the stuffing box, electric motor; only several drops, (para 3-11, 3-12)
6. To prevent breakdowns and, therefore, the need for repair. (para 3-13)
7. c, (para 3-17)
8. c, (para 3-19)
9. attach weights to the lower end, (para 3-27)
10. c, (para 3-28)
11. Indicates application of voltage to the heating element. (para 3-25)
12. a. daily
B. weekly
c. 200-hour, (para 3-30)
13. Insure adequate ventilation and no open flames are near. (para 3-32)
14. Two or three drops per cup and every six months. (para 3-33)
15. c. 230° F, (para 3-37)
16. Protects electrical circuits from overloading. (para 3-39)

17. glossy prints; matte prints, (para 3-39)
18. d. 20 minutes, (para 3-40)
19. MOTOR; ON, (para 3-40)
20. Squeegee lever, (para 3-41)
21. b. 1/2 inch, (para 3-41)
22. a. Preparatory
- b. Start
- c. Equipment Performance.
- d. Stop, (para 3-46)
23. Glowlamp glows, (para 3-46)
24. Turn in equipment for higher echelon repair. (para 3-46).