

US ARMY INTELLIGENCE CENTER
CIRCUITS

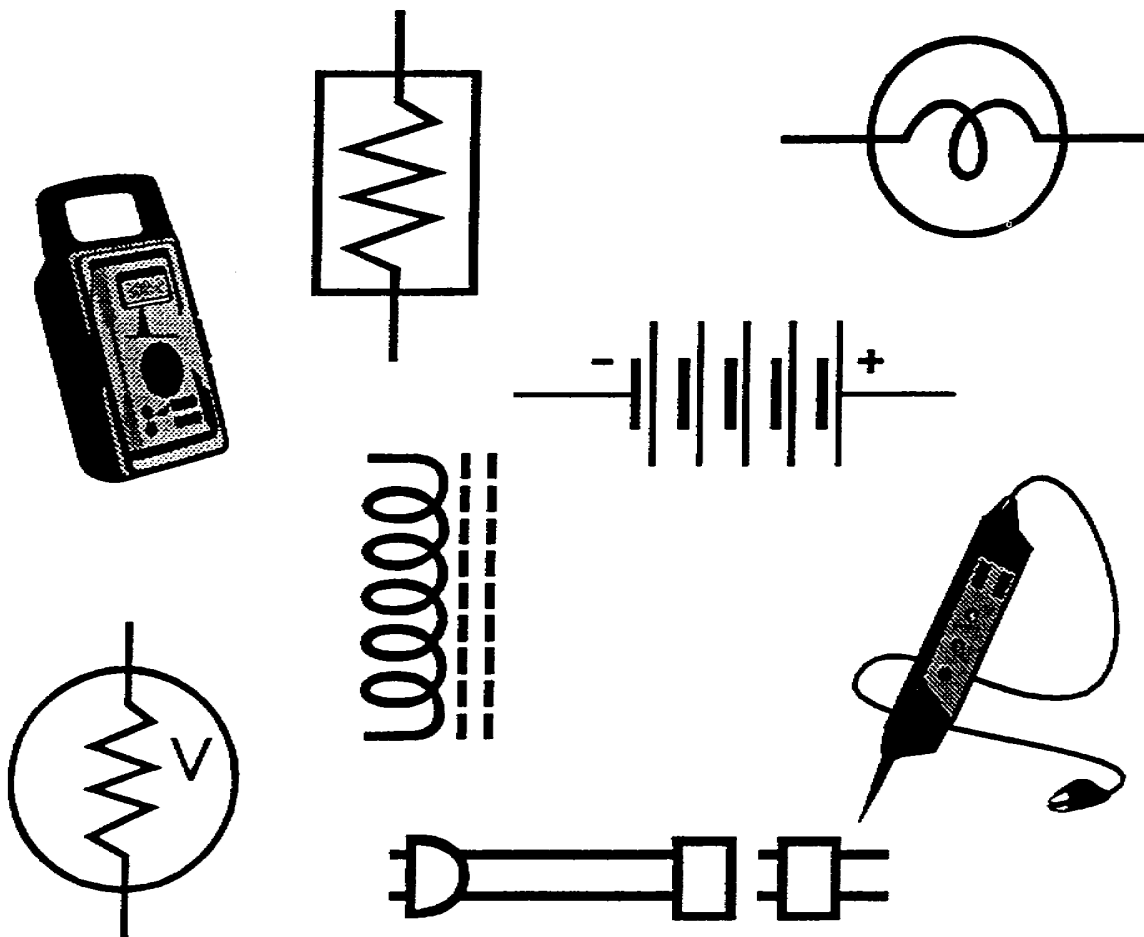

THE ARMY INSTITUTE FOR PROFESSIONAL DEVELOPMENT
ARMY CORRESPONDENCE COURSE PROGRAM

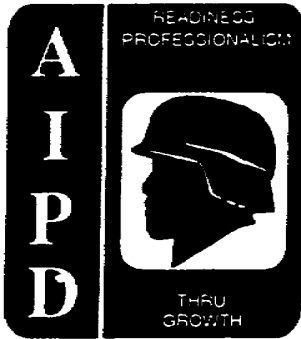

CIRCUITS

Subcourse Number IT0334

EDITION C

US ARMY INTELLIGENCE CENTER
FORT HUACHUCA, AZ 85613-6000

4 Credit Hours

Edition Date: December 1995

SUBCOURSE OVERVIEW

This subcourse is designed to teach you to calculate values in DC series circuits and to solve for unknown values of voltage, current and resistance in series-parallel circuits. There are two prerequisites for this subcourse. You should already have completed subcourses IT 0332 and IT 0333. If this material is strictly review for you, you may be able to take the subcourses out of order. In that case, remember that this subcourse builds upon material learned in the preceding subcourses. If you encounter any difficulty, go back to those subcourses.

This Subcourse replaces SA0703 and SA0704.

TERMINAL LEARNING OBJECTIVE.

- ACTION:** You will calculate resistance, current, voltage, and power in DC series circuits and solve for unknown values of voltage, current and resistance in series-parallel circuits.
- CONDITION:** You will use the information provided in this subcourse.
- STANDARD:** To demonstrate competency of this task, you must achieve a minimum of 70% on the subcourse examination.

TABLE OF CONTENTS

Section	Page
Subcourse Overview	i
Lesson 1: DC Series Circuits	1-1
Practice Exercise	1-29
Answer Key and Feedback	1-34
Lesson 2: Series-Parallel Circuits	2-1
Part A: Series Circuits Connected in Parallel	2-2
Part B: Parallel Circuits Connected in Series	2-15

LESSON 1

DC SERIES CIRCUITS

OVERVIEW

LESSON DESCRIPTION:

Upon completion of this lesson, you will be able to calculate values in DC series circuits.

This lesson replaces SA 0703.

TERMINAL LEARNING OBJECTIVE:

ACTION: Calculate resistance, current, voltage, and power in DC series circuits.

CONDITION: Given the information provided in this lesson.

STANDARD: To demonstrate competency of this task, you must achieve a minimum of 70 percent on the subcourse examination.

INTRODUCTION

In any type of work that uses the effects of electron flow, a knowledge of series or parallel circuits is desirable. None of the effects which accompany electron flow--for example, heating, lighting, or magnetic effects--are possible without the use of electric circuits, and many electric devices can be more effectively used if the operator has a knowledge of how the basic circuits work.

An electric circuit is a complete path through which electrons flow from the negative terminal of the voltage source, through the connecting wires, through the load, and back to the positive terminal of the voltage source. A circuit is thus made up of a voltage source, the necessary connecting wires, and the load.

A series circuit is defined as two or more component parts connected end to end to form only one path for current flow.

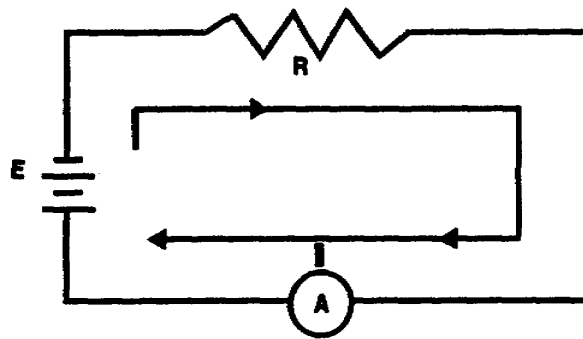

In the electric circuit shown above, current flows from the negative terminal of the battery, through the resistor, the ammeter, and back into the positive terminal of the battery.

The electron flow in a series circuit may be compared to the fluid flow in a hydraulic system as illustrated below.

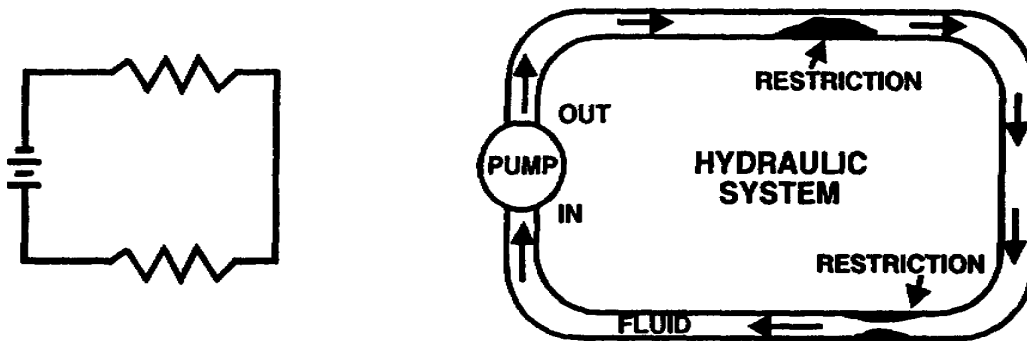

In each circuit, the fluid or current has only one path to follow. The battery in the electric circuit compares in action to the pump in the hydraulic system. The resistors in the electric circuit compare to the physical restrictions shown in the hydraulic system.

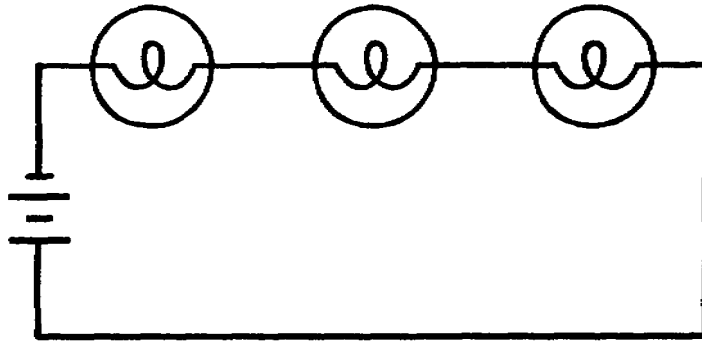

The series circuit above contains three lamps. The current flow from the battery must flow through each lamp in succession in order to complete the electrical path. When one lamp burns out, the electrical path is interrupted, and no current flows in the circuit; therefore, none of the lamps will light.

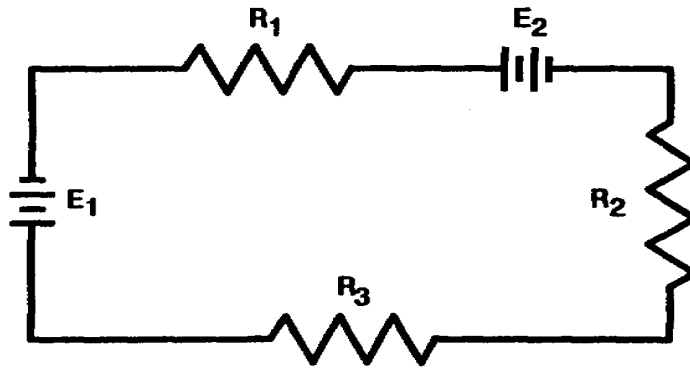

The series circuit above contains three resistors and two batteries. Each resistor is labeled with an "R," the symbol for resistance. In addition, each "R" is followed with a numeral to identify the specific resistor (R1, R2, etc.). The batteries are identified in a similar manner. When performing calculations in electric circuits containing two or more components, it becomes necessary to use subscripts to identify specific values. Subscripts are numbers or letters written below and to the right of the original circuit function letter, as in I_{R1} or E_{R3} (I_{R1} is read "I sub R1"). Total circuit values are normally identified with a subscript "t." Total voltage, total current, and total resistance are identified as E_t , I_t , and R_t .

PROBLEM:

How many paths for current flow are there in a series circuit?

- A. One
- B. Two
- C. Three
- D. Four

ANSWER:

A. There is only one path for current flow in a series circuit.

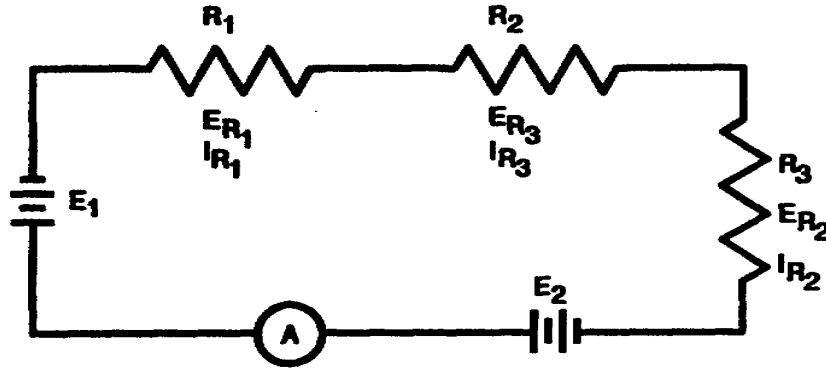

Referring to the circuit above, note that the physical components are identified as R1, R2, R3, E1 and E2. The electrical values are associated with the physical components by the use of subscripts. Voltage drops across the resistors are identified as E_{R1} , E_{R2} and E_{R3} . The current flowing through each resistor is identified as I_{R1} , I_{R2} and I_{R3} . Each value, such as E_{R1} or I_{R2} , is specifically associated with a component by the proper use of subscripts (R1 and R2). The total current flow in the circuit is measured by the indicated meter and identified as I_t .

PROBLEM:

What is the definition of a series circuit?

ANSWER:

A series circuit is defined as a circuit having two or more components connected end to end to form only one path for current flow.

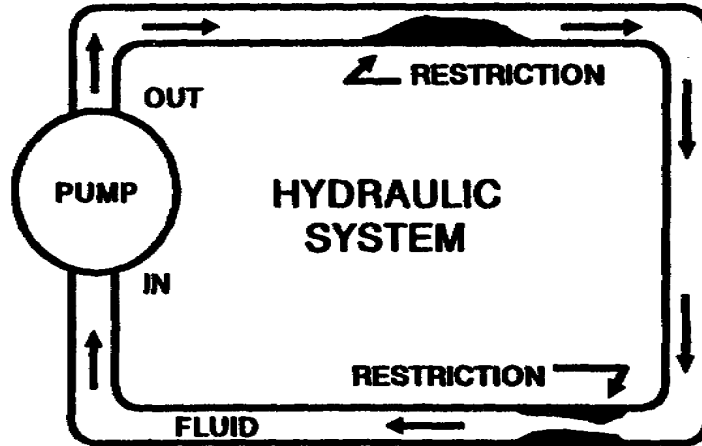

In the hydraulic system shown above, when fluid is flowing out of the pump at the rate of three gallons per minute, fluid must be flowing into the other side of the pump at the rate of three gallons per minute. Therefore, the rate of flow of fluid throughout the system must be constant. Similarly, this same concept is true regarding current flow in the series circuit shown below. When current is flowing out of the negative terminal of the battery at the rate of three amperes, the current flowing into the positive terminal to the battery is at the same rate, or three amperes.

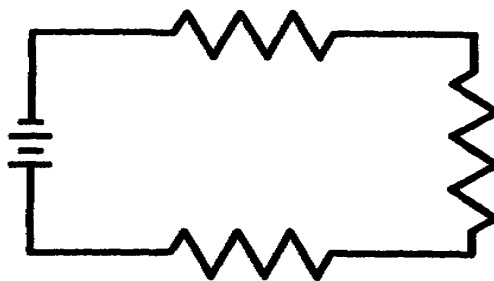

(CONTINUED)

Since the current flow in the series circuit is the same throughout the circuit, the value of current flowing through any resistor (I_{R1} , I_{R2} , and I_{R3}) is equal to the value of total current (I_t). The formula which expresses this relation is

$$I_t = I_{R1} = I_{R2} = I_{R3}$$

PROBLEMS:

a. The total current in a series circuit is _____ to the current through any resistor in the circuit.

b. Select the formula used to express the relationship of current throughout a series circuit.

A. $I_t + I_{R1} + I_{R3} = I_{R2}$

B. $I_t = I_{R1} + I_{R2} + I_{R3}$

C. $I_t = I_{R1} = I_{R2} = I_{R3} = \dots$

c. Match each symbol in column A with the function it represents in column B.

A		B
_____ (1)	I_t	a. Current flow through R1.
_____ (2)	R_t	b. Total resistance.
_____ (3)	I_{R1}	c. Total current.
_____ (4)	E_{R3}	d. Voltage drop across R3.

d. What is the definition of a series circuit?

ANSWERS :

a. equal

b. C

c. (1) c.

(2) b.

(3) a.

(4) d.

d. Two or more components connected end to end to form only one path for current flow.

The total resistance of a series circuit is calculated by adding the individual resistances of the resistors in the circuit. The sum of the individual resistances in the circuit below is equal to the total resistance. This relation is expressed as

$$R_t = R_1 + R_2 + R_3$$

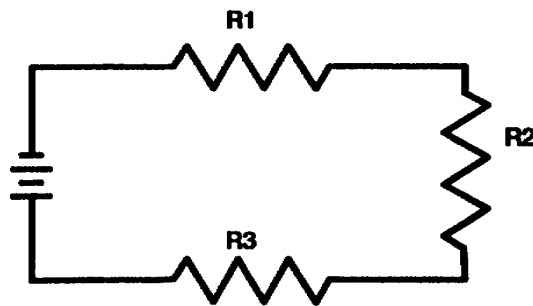

PROBLEMS :

a. The sum of the individual resistances in a series circuit is equal to the _____ resistance of the circuit.

b. Select the formula used to solve for total resistance in a series circuit.

A. $R_t = R_1 = R_2 = R_3$

B. $R_t = R_1 + R_2 + R_3$

C. $R_t + R_1 + R_2 = R_3$

D. $R_t = R_1 + R_2 = R_3$

c. Match each symbol in column A with the circuit function it represents in column B.

A		B
_____	(1) I_{R1}	a. Current through R1.
_____	(2) I_t	b. Total resistance.
_____	(3) R_t	c. Resistor R3.
_____	(4) E_t	d. Total voltage.
_____	(5) E_{R1}	e. Total current.
_____	(6) R3	f. Voltage drop across R1.

ANSWERS :

- a. total
- b. B.
- c. (1) a.
(2) e.
(3) b.
(4) d.
(5) f.
(6) c.

The total voltage in a series circuit is equal to the sum of the individual voltage drops across the resistors in that circuit.

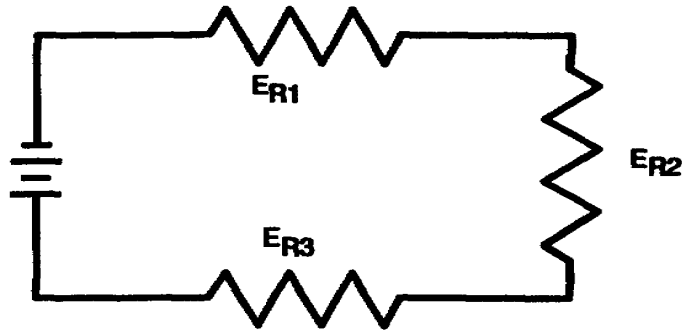

The series circuit containing three resistors (R_1 , R_2 , and R_3) has three voltage drops (E_{R1} , E_{R2} and E_{R3}) . The sum of these three voltage drops is equal to the total voltage. Expressed mathematically:

$$E_t = E_{R1} + E_{R2} + E_{R3}$$

PROBLEMS :

a. Total voltage in a series circuit equal to the _____ of the individual voltage drops.

b. Select the formula used to solve for total voltage in a series circuit.

A. $E_t + E_{R1} + E_{R2} = E_{R3}$

B. $E_t = E_{R1} = E_{R2} = E_{R3}$

C. $E_t = E_{R1} + E_{R2} = E_{R3}$

D. $E_t = E_{R1} + E_{R2} + E_{R3}$

c. Write the formula used to solve for total current (I_t) in the circuit below.

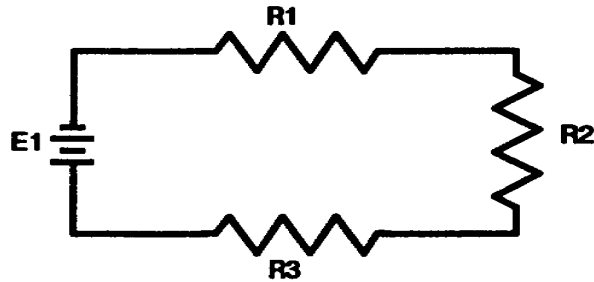

d. Write the formula used to solve for total resistance (R_t) in the circuit below.

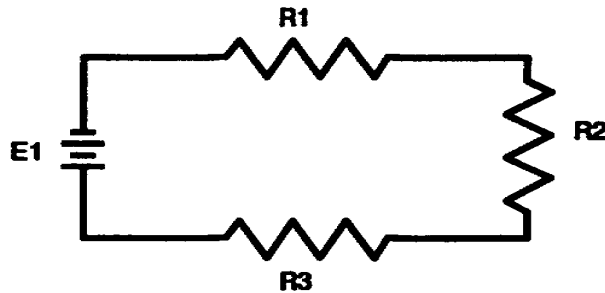

e. Write the formula used to solve for total voltage (E_t) in the circuit below.

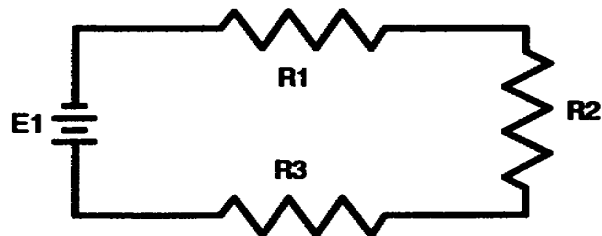

ANSWERS :

a. sum

b. D.

c. $I_t = I_{R1} = I_{R2} = I_{R3}$

d. $R_t = R_1 + R_2 + R_3$

e. $E_t = E_{R1} + E_{R2} + E_{R3}$

The solution of a typical series circuit problem requires the application of Ohm's law and the series circuit formulas contained in this lesson. The formulas used are determined by analyzing the information given in the problem and the answers required.

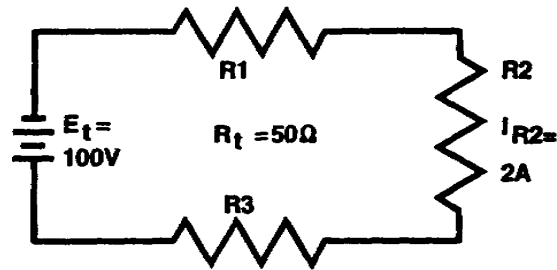

Refer to the circuit above. When the current flowing through any resistor is known or can be calculated, the total current is determined by using the formula

$$I_t = I_{R1} = I_{R2} = I_{R3}$$

$$I_t = I_{R2}$$

$$I_t = 2 \text{ A}$$

The total current in the circuit above may also be calculated by using the Ohm's law formula

$$I_t = \frac{E_t}{R_t}$$

$$= \frac{100 \text{ volts}}{50 \text{ ohms}}$$

$$I_t = 2 \text{ A}$$

PROBLEMS :

a. Solve for I_t in the circuit below.

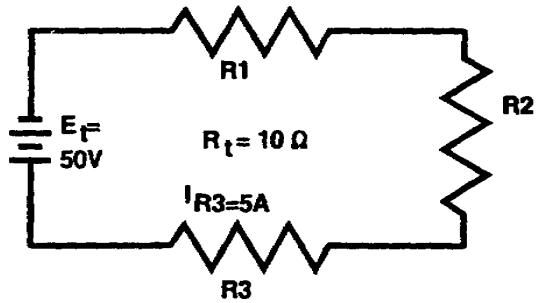

b. Select the value of total current (I_t) in the circuit below.

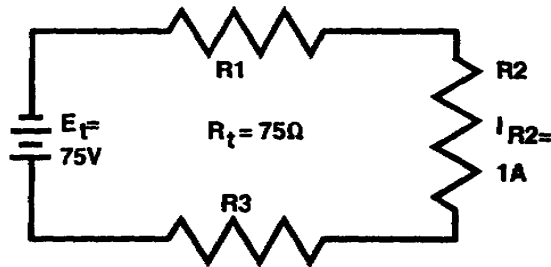

A. 0.5 A

C. 1.5 A

B. 1.0 A

D. 2.0 A

ANSWERS :

a. 5 A

b. B. (1.0 amps)

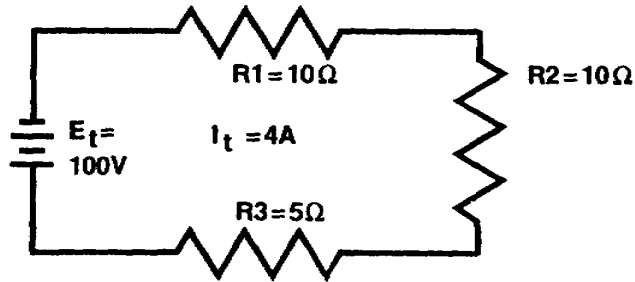

The total resistance in the circuit above may be calculated by using the formula

$$\begin{aligned} R_t &= R_1 + R_2 + R_3 \\ &= 10 \text{ ohms} + 10 \text{ ohms} + 5 \text{ ohms} \end{aligned}$$

$$R_t = 25 \text{ ohms}$$

The total resistance in the circuit above may also be calculated by using the formula derived from Ohm's law:

$$\begin{aligned} R_t &= \frac{E_t}{I_t} \\ &= \frac{100 \text{ volts}}{4 \text{ amps}} \end{aligned}$$

$$R_t = 25 \text{ ohms}$$

PROBLEM:

Solve for R_t in the circuit below.

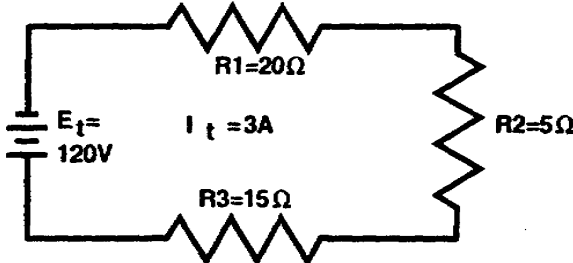

ANSWER: 40 ohms

Since $R_t = R_1 + R_2 = R_3$

we have: $R_t = 20 \text{ ohms} + 5 \text{ ohms} + 15 \text{ ohms}$

$R_t = 40 \text{ ohms}$

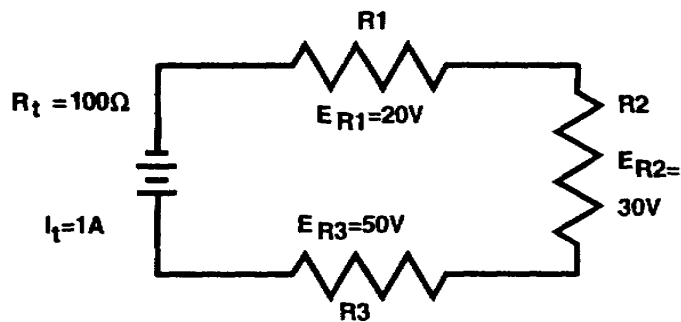

When the voltage drops across the resistors in a series circuit are known, the total voltage may be calculated by using the formula

$$\begin{aligned} E_t &= E_{R1} + E_{R2} + E_{R3} \\ &= 20 \text{ volts} + 30 \text{ volts} + 50 \text{ volts} \end{aligned}$$

$$E_t = 100 \text{ volts}$$

The total voltage in a circuit may also be calculated by using the formula derived from Ohm's law:

$$\begin{aligned} E_t &= I_t \times R_t \\ &= 1 \text{ amp} \times 100 \text{ ohms} \end{aligned}$$

$$E_t = 100 \text{ volts}$$

PROBLEM:

Solve for E_t in the circuit below.

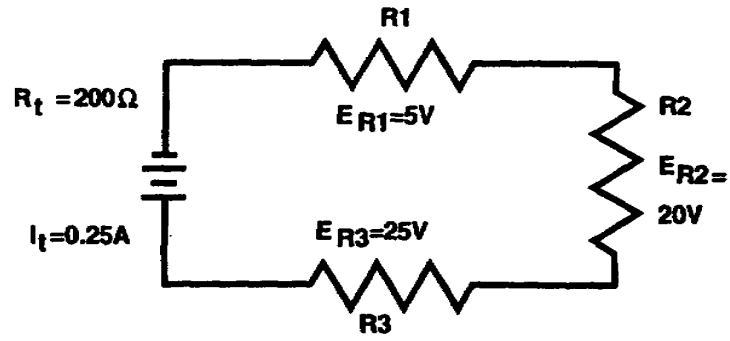

ANSWER: 50 volts

Since $E_t = I_t \times R_t$,

we have: $E = .25 \text{ amps} \times 200 \text{ ohms}$

$E = 50 \text{ volts}$

PROBLEMS:

a. Select the value of total voltage (E_t) applied to the circuit below.

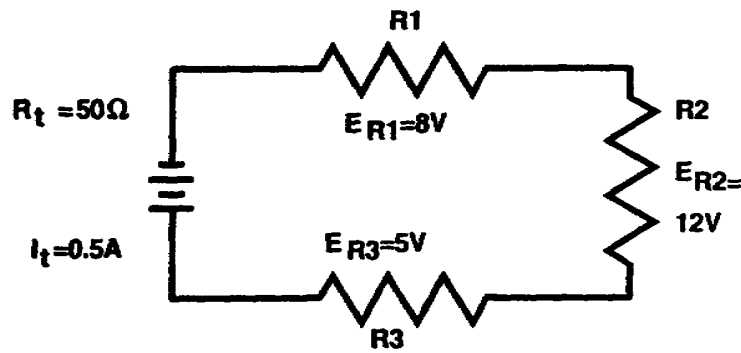

- A. 5 V
- B. 10 V
- C. 25 V
- D. 50 V

b. Calculate the total current (I_t) in the circuit below.

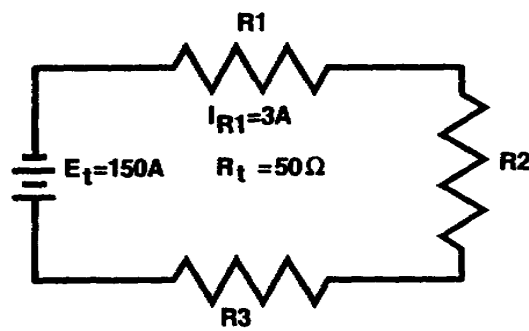

ANSWERS :

- a. C. 25 V
- b. 3 amps

Most unknown values in a series circuit may be calculated a number of different ways with various formulas. The shortest method of calculation is determined by analyzing the information given in the problem. Recognizing the shortest possible way to solve a problem comes with practice and experience.

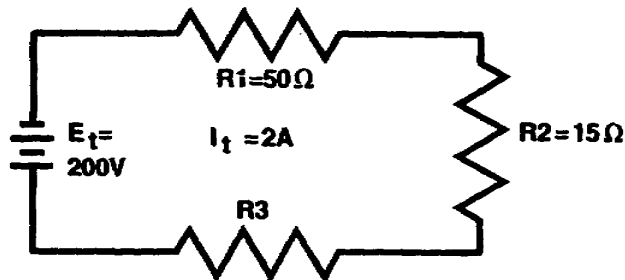

In the circuit above, the values of E_{R1} , E_{R2} , E_{R3} , I_{R1} , I_{R2} , and I_{R3} are to be calculated. Referring to the chart below, analyze the known values.

	COMPONENT		
	R1	R2	R3
$E_t = 200 \text{ V}$	E_{R1}	E_{R2}	E_{R3}
$I_t = 2 \text{ A}$	I_{R1}	I_{R2}	I_{R3}
R_t	$R1 = 50 \text{ OHMS}$	$R2 = 15 \text{ OHMS}$	$R3$

(CONTINUED)

Since the rate of current is constant throughout a series circuit, the value of 2 amperes (I_t) is designated as the value of current through R_1 , R_2 , and R_3 , as shown in the chart below.

	COMPONENT		
	R1	R2	R3
$E_t = 200 \text{ V}$	E_{R1}	E_{R2}	E_{R3}
$I_t = 2 \text{ A}$	$I_{R1} = 2 \text{ A}$	$I_{R2} = 2 \text{ A}$	$I_{R3} = 2 \text{ A}$
R_t	$R1 = 50 \text{ ohms}$	$R2 = 15 \text{ ohms}$	$R3$

Total resistance of the circuit is computed in the following manner:

$$R_t = \frac{E_t}{I_t}$$
$$= \frac{200 \text{ volts}}{2 \text{ amps}}$$

$$R_t = 100 \text{ ohms}$$

Since R_t is equal to 100 ohms and $R_t = R_1 + R_2 + R_3$, the value of R_3 , the value of R_3 may be calculated by subtracting the known resistances from R_t .

This difference is then equal to the value of the unknown resistor. Expressed mathematically:

$$R_t = R_1 + R_2 + R_3$$

$$R_3 = R_t - R_1 - R_2$$

$$R_3 = 100 \text{ ohms} - 50 \text{ ohms} - 15 \text{ ohms}$$

$$R_3 = 35 \text{ ohms}$$

(CONTINUED)

All values are now known, as shown in the chart below, except the voltage drop across each resistor.

	COMPONENT		
	R1	R2	R3
$E_t = 200 \text{ V}$	E_{R1}	E_{R2}	E_{R3}
$I_t = 2 \text{ A}$	$I_{R1} = 2 \text{ A}$	$I_{R2} = 2 \text{ A}$	$I_{R3} = 2 \text{ A}$
$R_t = 100 \text{ ohms}$	$R1 = 50 \text{ ohms}$	$R2 = 15 \text{ ohms}$	$R3 = 35 \text{ ohms}$

The calculations for the voltage drops are performed by using the Ohm's law formulas.

$$E_{R1} = I_{R1} \times R_1$$

$$= 2 \text{ A} \times 50$$

$$E_{R1} = 100 \text{ volts}$$

$$E_{R2} = I_{R2} \times R_2$$

$$= 2 \text{ A} \times 15$$

$$E_{R2} = 30 \text{ volts}$$

$$E_{R3} = I_{R3} \times R_3$$

$$= 2 \text{ A} \times 35$$

$$E_{R3} = 70 \text{ volts}$$

When the values of E_{R1} , E_{R2} , and E_{R3} are inserted into the chart below, it is readily seen that $E_t = E_{R1} + E_{R2} + E_{R3}$.

	COMPONENT		
	R1	R2	R3
$E_t = 200 \text{ V}$	$E_{R1} = 100 \text{ V}$	$E_{R2} = 30 \text{ V}$	$E_{R3} = 70 \text{ V}$
$I_t = 2 \text{ A}$	$I_{R1} = 2 \text{ A}$	$I_{R2} = 2 \text{ A}$	$I_{R3} = 2 \text{ A}$
$R_t = 100 \text{ ohms}$	$R1 = 50 \text{ ohms}$	$R2 = 15 \text{ ohms}$	$R3 = 35 \text{ ohms}$

PROBLEMS:

a. Solve for E_{R1} , E_{R2} , and E_{R3} in the circuit below.

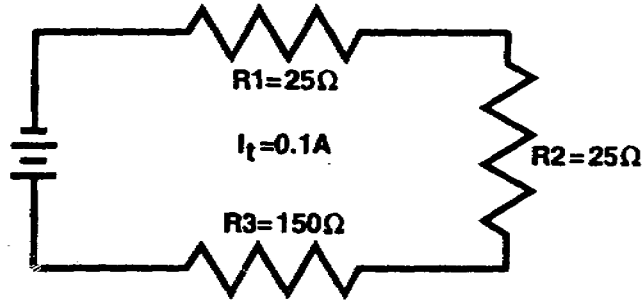

b. Solve for E_{R1} , E_{R2} , and E_{R3} in the circuit below.

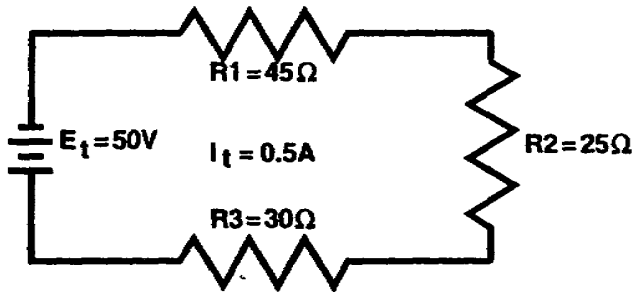

ANSWERS :

- a. $E_{R1} = 2.5 \text{ V}$, $E_{R2} = 2.5 \text{ V}$, $E_{R3} = 15 \text{ V}$
 b. $E_{R1} = 22.5 \text{ V}$, $E_{R2} = 12.5 \text{ V}$, $E_{R3} = 15 \text{ V}$

PROBLEMS:

- a. Calculate the total resistance (R_t) in the series circuit below.

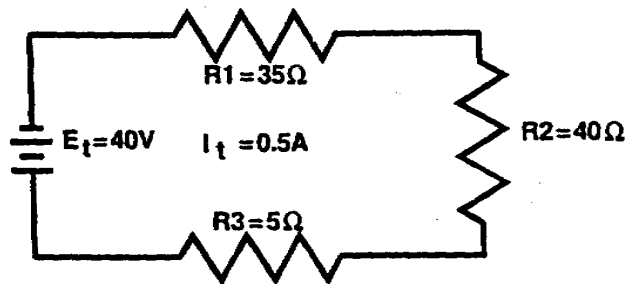

- b. Calculate the total voltage (E_t) applied to the circuit below.

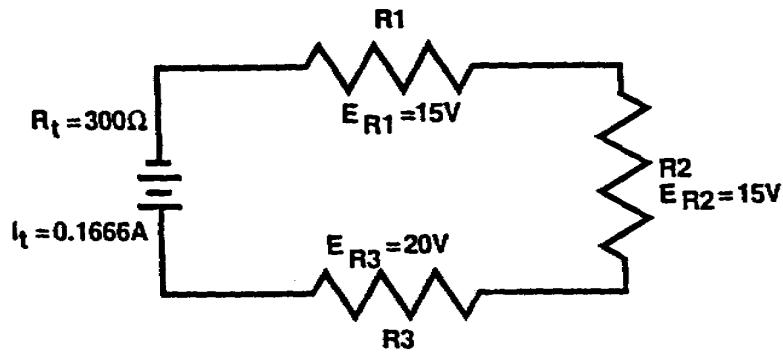

- c. Solve for the values of E_{R1} , E_{R2} , and E_{R3} in the circuit below.

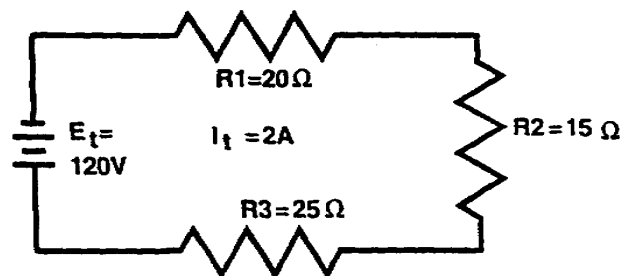

ANSWER:

- a. 80 ohms
- b. 50 volts
- c. $E_{R1} = 40 \text{ V}$, $E_{R2} = 30 \text{ V}$, $E_{R3} = 50 \text{ V}$

A practical application of the laws of DC series circuits is demonstrated in the study of batteries. A battery is made up of two or more cells which may be connected in series, parallel, or series-parallel combinations. This lesson is concerned with the series configuration only.

When connecting cells to form a battery, the voltage and current requirements for the particular application determine the method of connection. The advantage of connecting cells in series is that a higher output voltage is obtained. The voltage law for a series circuit states that the sum of the voltage drops around a closed circuit is equal to the applied voltage, or

$$E_t = E_1 + E_2 + E_3$$

Therefore, when battery cells are connected in series, the total voltage is equal to the sum of the cell voltages, as shown below.

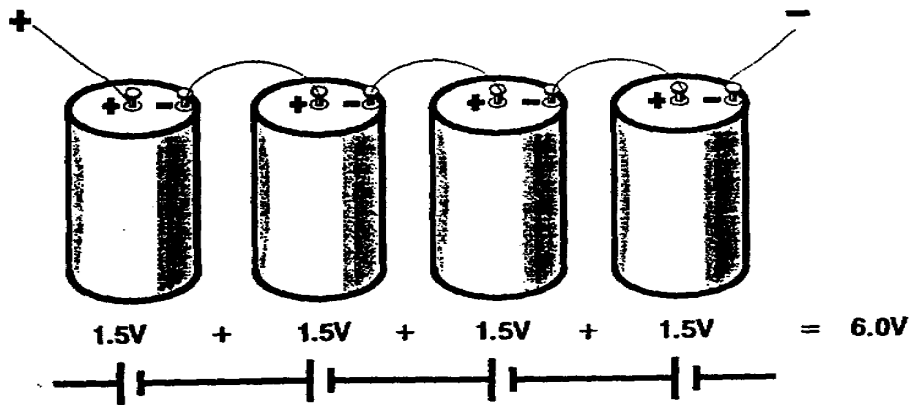

There are two basic types of battery cells. These are (1) the primary cell (sometimes referred to as a "dry cell" because the electrolyte is in paste form) and (2) the secondary cell (sometimes referred to as a "wet cell" because the electrolyte is in liquid form). Both types of cells are widely used.

One of the most popular primary cells in use is the flashlight cell. The output voltage of the primary cell is about 1.5 volts when new.

The output voltage of the secondary cell is about 2 volts. This voltage will vary with specific types of cells. For example, the lead-acid cell used in the automobile battery has an output of 2.2 volts. The so-called 12-volt automobile battery consists of six cells connected in series.

PROBLEM:

Select the advantage of connecting battery cells in series.

- A. Economy.
- B. Less weight.
- C. Higher output current is obtained.
- D. Higher output voltage is obtained.

ANSWER: D. Higher output voltage is obtained.

LESSON 1

PRACTICE EXERCISE

The following items will test your grasp of the material contained in this lesson. There is only one correct answer for each item. When you complete this exercise, check your answers with the answer key that follows. If you answer any item incorrectly, study again that part of the lesson which contains the portion involved.

1. Define a series circuit.

2. Match each symbol in column A with the circuit function it represents in column B.

A		B
_____	(1) R_t	a. Current flow through resistor R2.
_____	(2) I_t	b. Total resistance.
_____	(3) E_t	c. Resistor R3.
_____	(4) I_{R2}	d. Total voltage.
_____	(5) E_{R1}	e. Total current.
_____	(6) R3	f. Voltage drop across resistor R1.

(CONTINUED)

3. Write the formula used to determine total current (I_t) in the circuit below.

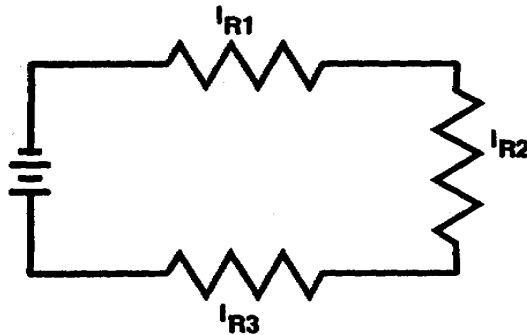

4. Write the formula used to solve for total resistance (R_t) in the circuit below.

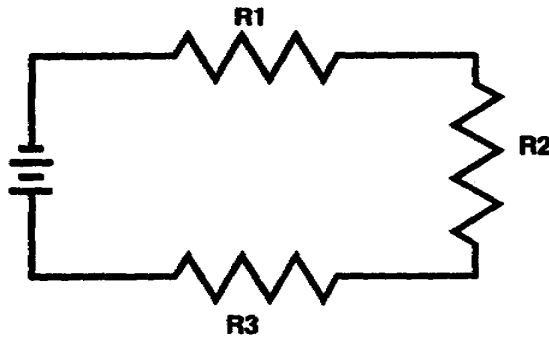

5. Write the formula used to solve for total voltage (E_t) in the circuit below.

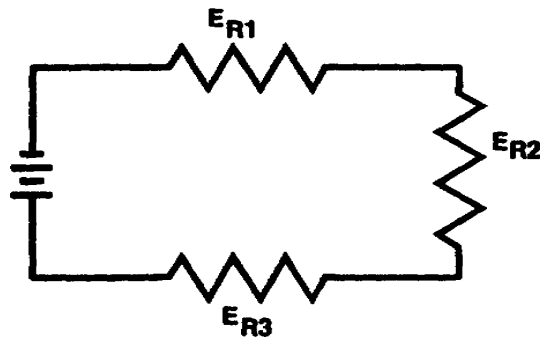

(CONTINUED)

6. Calculate the total current (I_t) in the circuit below.

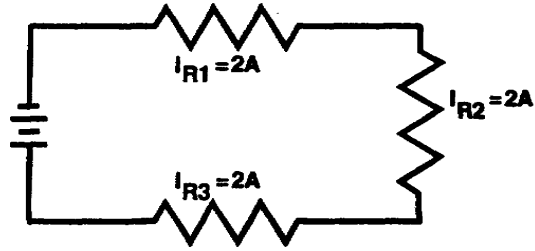

7. Calculate the total resistance (R_t) in the circuit below.

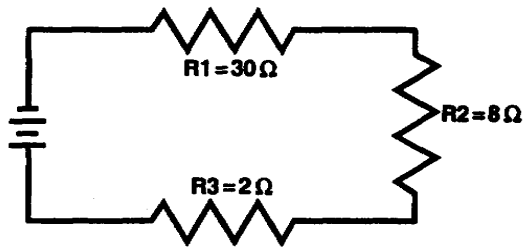

(CONTINUED)

8. Calculate the total voltage (E_t) applied to the circuit below.

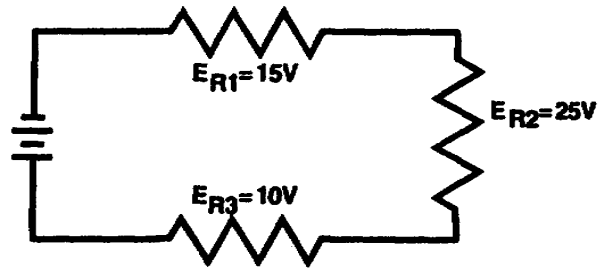

9. Solve for the values of E_{R1} , E_{R2} , and E_{R3} in the circuit shown below.

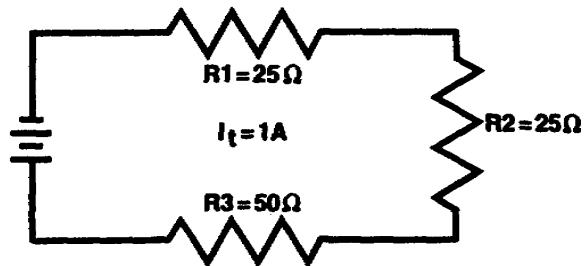

10. State the advantage of connecting battery cells in series.

11. State the voltages developed by the following cells.

a. a single carbon - zinc cell (flashlight battery).

b. a single lead-acid cell (automobile battery).

LESSON 1

PRACTICE EXERCISE

ANSWER KEY AND FEEDBACK

1. Two or more components connected end to end to form only one path for current flow.
2. (1) b.
(2) e.
(3) d.
(4) a.
(5) f.
(6) c.
3. $I_t = I_{R1} = I_{R2} = I_{R3}$
4. $R_t = R_1 + R_2 + R_3$
5. $E_t = E_{R1} + E_{R2} + E_{R3}$
6. $I_t = 2 \text{ A}$
7. $R_t = 40 \text{ ohms}$
8. $E_t = 50 \text{ V}$
9. $E_{R1} = 25 \text{ V}$
 $E_{R2} = 25 \text{ V}$
 $E_{R3} = 50 \text{ V}$
10. A higher output voltage is obtained.
11. a. 1.5 V
b. 2.0 V

LESSON 2

SERIES-PARALLEL CIRCUITS

OVERVIEW

LESSON DESCRIPTION:

Upon completion of this lesson, you will be able to solve for unknown values of voltage, current and resistance in series-parallel circuits.

Lesson 2 replaces SA0704.

TERMINAL LEARNING OBJECTIVE

ACTION: Solve for unknown values of voltage, current and resistance in series-parallel circuits.

CONDITION: Given the information provided in this lesson.

STANDARD: To demonstrate competency of this task, you must achieve a minimum of 70 percent on the subcourse examination.

PART A

SERIES CIRCUITS CONNECTED IN PARALLEL

A series-parallel circuit may consist of series circuits connected in parallel or it may consist of parallel circuits connected in series. You have had the necessary laws and formulas needed to solve series-parallel circuit problems. The important thing to remember is that when working with resistances connected in series, use series-circuit laws; and when working with resistances connected in parallel, use parallel-circuit laws.

The following formulas are based on the laws of series circuits.

Total resistance equals the sum of the individual resistances.

$$R_t = R_1 + R_2 + R_3 \dots$$

Current flow is the same across each resistance.

$$I_t = I_1 = I_2 = I_3 \dots$$

Total voltage equals the sum of the voltage drops across each resistance.

$$E_t = E_1 + E_2 + E_3 \dots$$

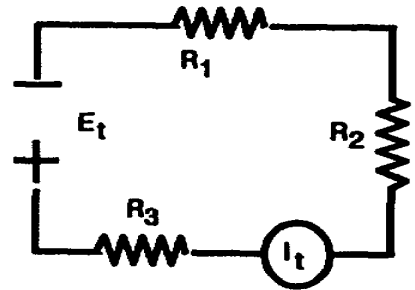

The following formulas are based on the laws of parallel circuits.

Total resistance is determined by the reciprocal method.

$$\frac{1}{R_t} = \frac{1}{R_1} + \frac{1}{R_2} + \frac{1}{R_3} \dots$$

Total current is equal to the sum of the current of each branch.

$$I_t = I_1 + I_2 + I_3 \dots$$

Total voltage is equal to the voltage of each branch.

$$E_t = E_1 = E_2 = E_3 \dots$$

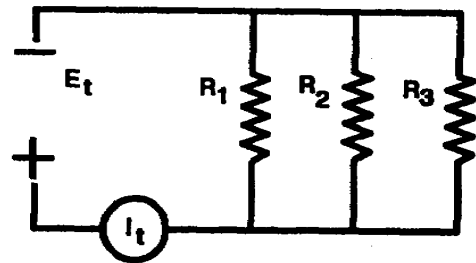

The circuit in figure A consists of two series circuits connected in parallel across a battery.

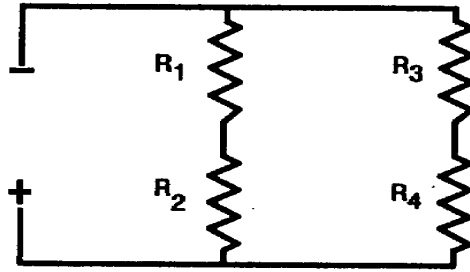

Figure A

Figure B shows resistances R_1 and R_2 connected in series with each other to form one path for current from the battery.

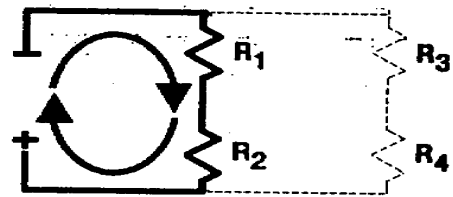

Figure B

Figure C shows resistances R_3 and R_4 connected in series to form a second path for current from the battery.

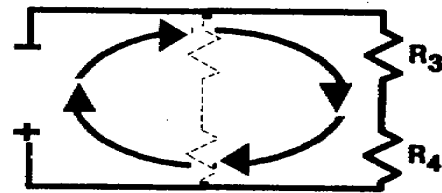

Figure C

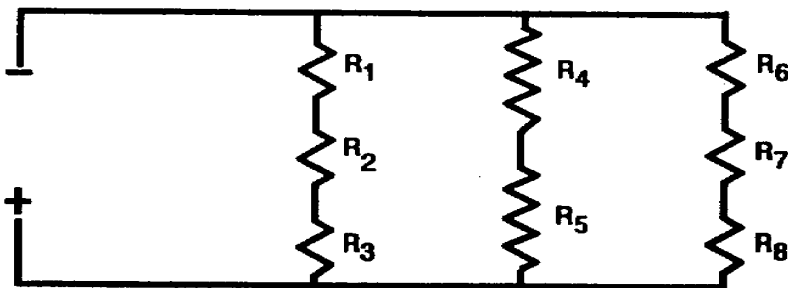

Figure D

Refer to figure D.

- How many series circuits are in this circuit? _____
- How many paths are there for current? _____
- How are these series circuits connected? _____

- a. THREE
- b. THREE
- c. PARALLEL

Draw connecting lines between the following components to form two series circuits connected in parallel.

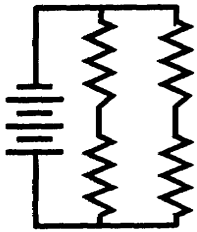
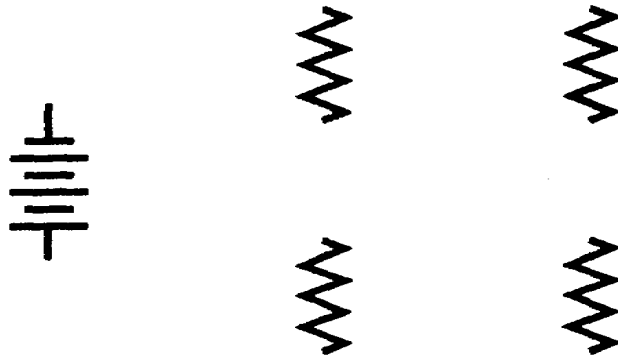

No new formulas are needed to find the values of series-parallel circuits. Instead, a simplified circuit is made of the original series-parallel circuit, and the necessary circuit laws are used for the simplified circuit.

The circuit in figure A below is electrically the same as the circuit in figure B.

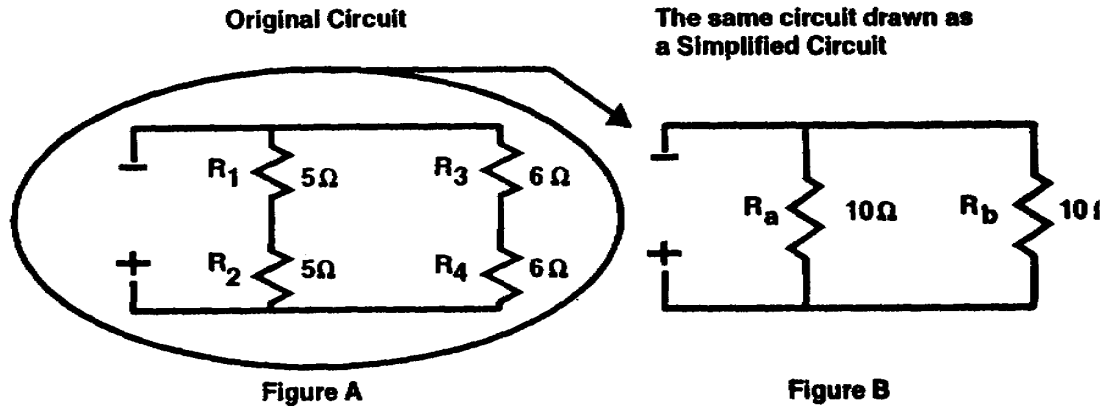

In figure A, the circuit has two paths for current; each path (branch) has a total of 10 ohms resistance. $R_1 + R_2$ gives the total resistance of the first branch. $R_3 + R_4$ gives the total resistance of the second branch. Figure B is the simplified circuit of the circuit in figure A. To solve for R_t in figure B, use _____ - circuit laws. (series/parallel)

$R_t = \underline{\hspace{2cm}}$ ohms

PARALLEL

Simplified circuits are very useful when solving series-parallel circuit problems.

5 OHMS

Draw and use simplified circuits when solving the problems in this program.

Figure B is the simplified drawing of the circuit in figure A. To solve for the total resistance of the circuit below, first, solve for the combined resistance of the series network R_1 , R_2 , and R_3 . This combined value is represented in the simplified circuit as R_a . Second, solve for the combined value of R_4 and R_5 . This combined value is represented in the simplified circuit as R_b .

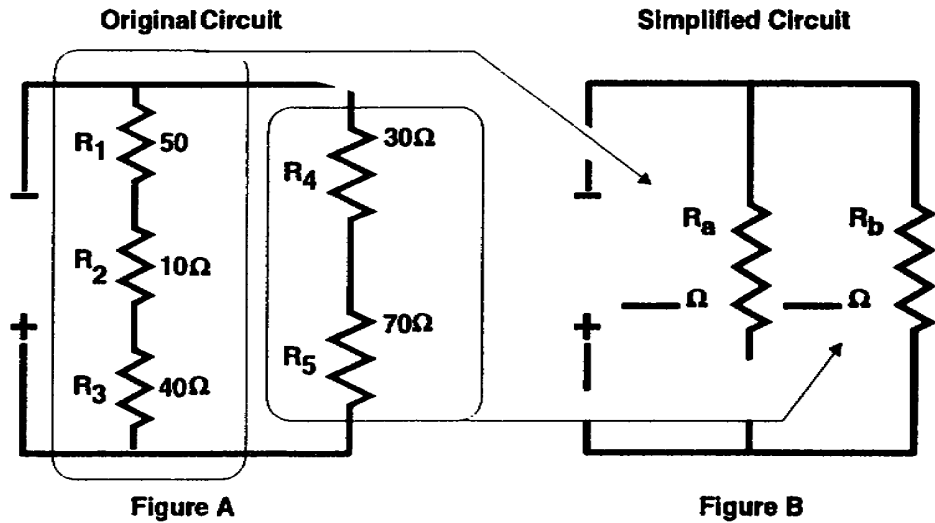

- The circuit in figure A consists of _____ series circuits connected in parallel.
- R_a in figure B represents which resistances in figure A? _____
- R_b in figure B represents which resistances in figure A? _____
- What is the value of R_a ? _____
- What is the value of R_b ? _____
- $R_t =$ _____ ohms.

- a. TWO
- b. R_1, R_2, R_3
- c. R_4, R_5
- d. 100 OHMS
- e. 100 OHMS
- f. 50 OHMS

The total current (I_t) in series circuits connected in parallel is equal to total voltage (E_t) divided by total resistance (R_t).

Total current is also equal to the sum of the branch currents.

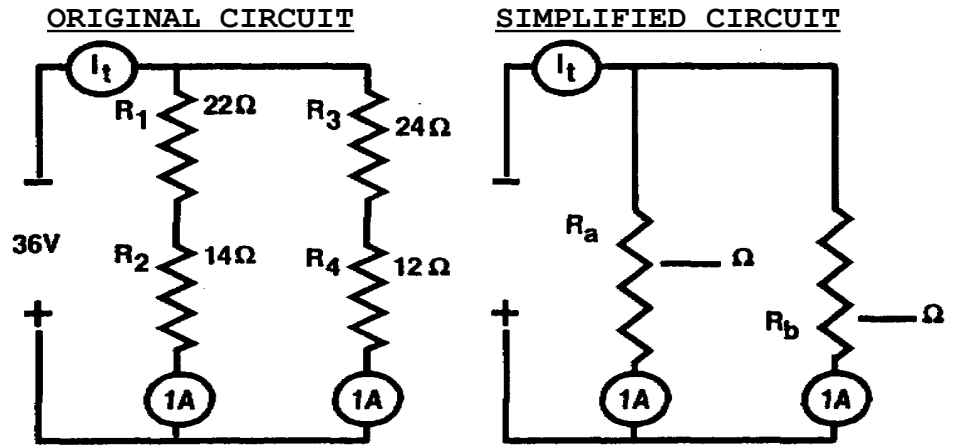

Using the illustrations above, solve for:

$R_a = \underline{\hspace{2cm}}$ ohms

$R_b = \underline{\hspace{2cm}}$ ohms

$R_t = \underline{\hspace{2cm}}$ ohms

$I_t = \underline{\hspace{2cm}}$ amps.

$$R_a = 36 \text{ OHMS}$$

$$R_b = 36 \text{ OHMS}$$

$$R_b = 18 \text{ OHM}$$

$$I_t = 2 \text{ AMPS}$$

- Complete the simplified circuit.
- Label the two branches in the simplified circuit as R_a and R_b .
- Use the completed simplified circuit to solve for I_t .

Remember, the current through each branch of a parallel network is equal to the voltage across the branch divided by the total resistance of the branch.

$$I_a = \frac{E_a}{R_a}$$

$$I_b = \frac{E_b}{R_b}$$

$$I_t = I_a + I_b$$

ORIGINAL CIRCUIT

SIMPLIFIED CIRCUIT

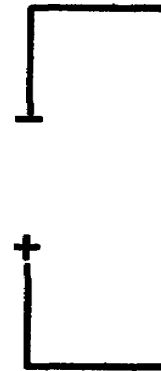
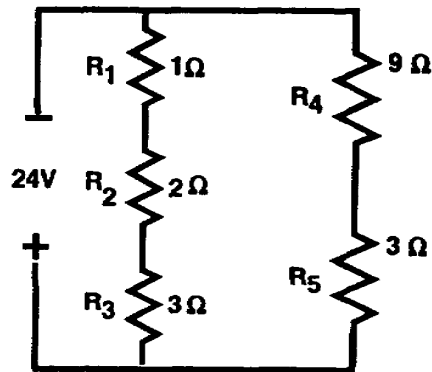

$$I_t = \underline{\hspace{2cm}} \text{ amps.}$$

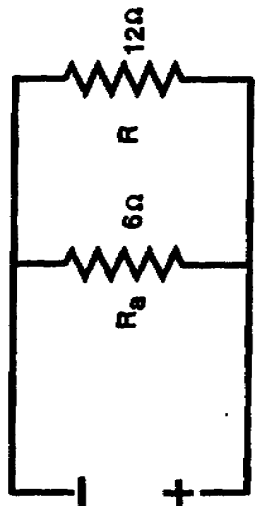

$I_t = 6 \text{ AMPS.}$

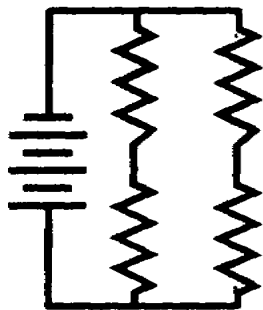

Draw connecting lines between the following components to form two series circuits connected in parallel.

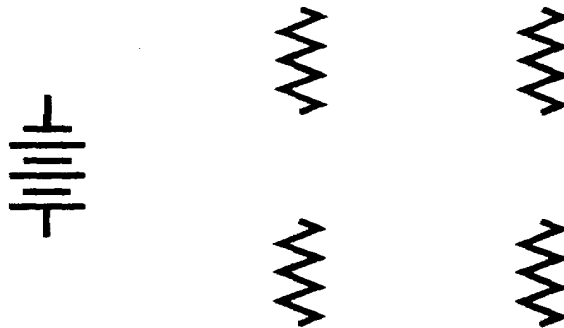

The total voltage (E_t) applied to series circuits connected in parallel is equal to I_t times R_t . E_t is also equal to the voltage across either of the parallel branches.

ORIGINAL CIRCUIT

SIMPLIFIED CIRCUIT

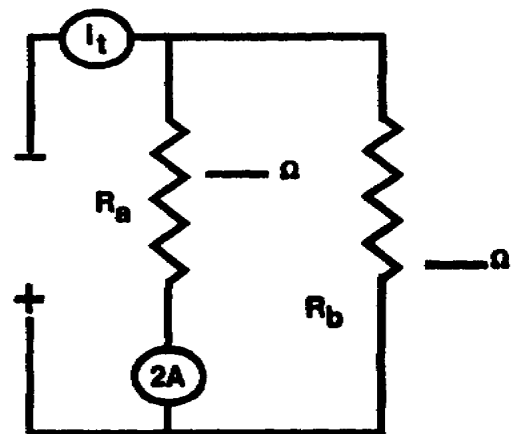
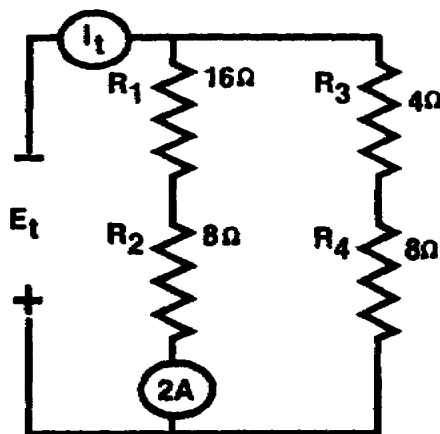

The simplified circuit shows two resistances in parallel; the voltage across either parallel branch is equal to the applied voltage (parallel voltage law).

$E_t = E_a$ $E_a = I_a \times R_a$

$I_a = \underline{\hspace{2cm}}$ amps.

$R_a = \underline{\hspace{2cm}}$ ohms

$E_a = \underline{\hspace{2cm}}$ volts

$E_t = \underline{\hspace{2cm}}$ volts

$$I_a = 2 \text{ AMPS.}$$

$$R_a = 24 \text{ OHMS}$$

$$E_a = 48 \text{ VOLTS}$$

$$E_t = 48 \text{ VOLTS}$$

The ammeter in the circuit below indicates the total current in the circuit. Complete the simplified circuit and solve for the values listed below.

ORIGINAL CIRCUIT

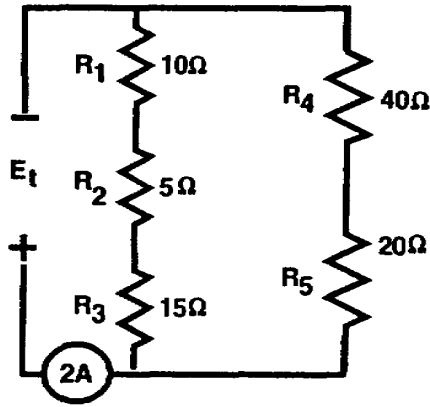

SIMPLIFIED CIRCUIT

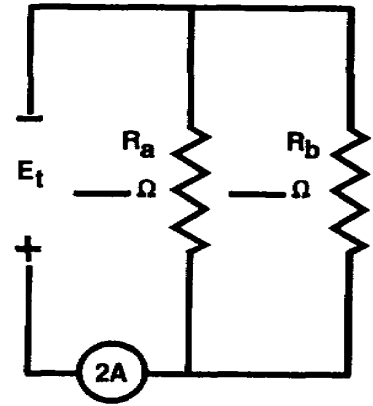

Ohm's law: $E_t = I_t \times R_t$

$$R_a = \underline{\hspace{2cm}} \text{ ohms}$$

$$R_b = \underline{\hspace{2cm}} \text{ ohms}$$

$$R_t = \underline{\hspace{2cm}} \text{ ohms}$$

$$I_t = \underline{\hspace{2cm}} \text{ amps.}$$

$$E_t = \underline{\hspace{2cm}} \text{ volts}$$

$R_a = 30 \text{ OHMS}$

$R_b = 60 \text{ OHMS}$

$R_t = 20 \text{ OHMS}$

$I_t = 2 \text{ AMPS.}$

$E_t = 40 \text{ VOLTS}$

Draw a simplified circuit of this circuit,
and solve for R_t .

ORIGINAL CIRCUIT

SIMPLIFIED CIRCUIT

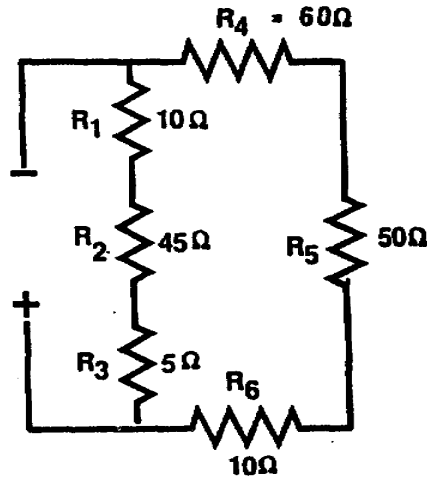

$R_t = \underline{\hspace{2cm}}$ ohms

Solve for the value of I_t .

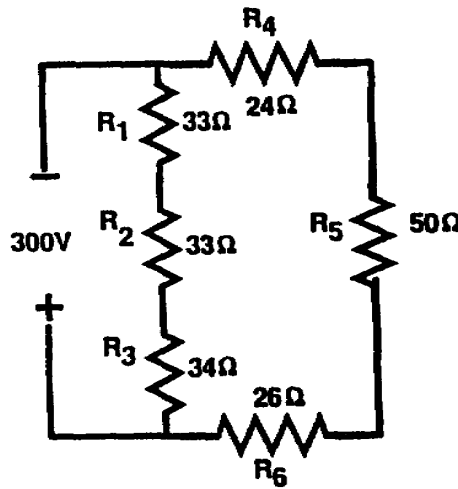
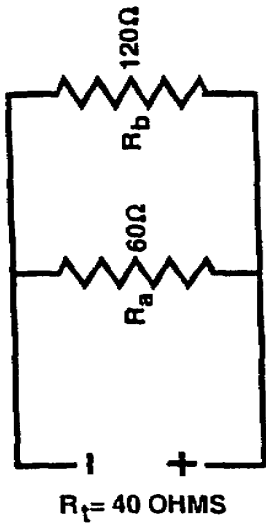

$I_t = \underline{\hspace{2cm}}$ amps.

$I_t = 6$ AMPS.

Solve for the value of E_t .

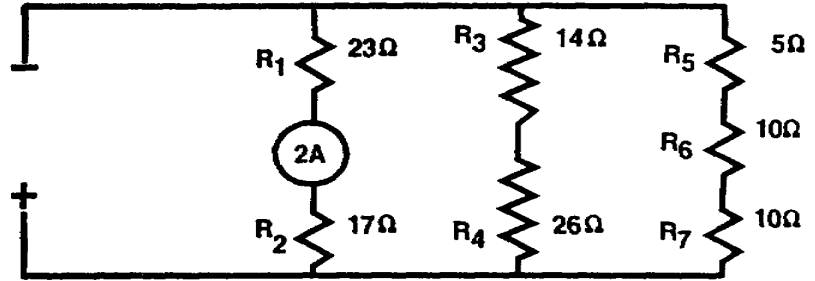

$E_t =$ _____ volts

$E_t = 80$ VOLTS

Solve for the value of I_t .

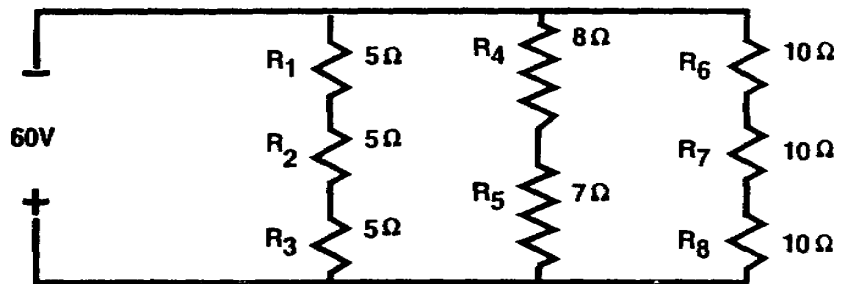

$I_t =$ _____ amps.

$I_t = 10$ AMPS.

- A series-parallel circuit is a combination of _____ and _____ circuits.
- A series-parallel circuit may consist of _____ circuits connected in parallel.
- A series-parallel circuit may consist of _____ circuits connected in series.
- When working with the portion of a series-parallel circuit having resistances connected in series, use _____-circuit laws.
- When working with the portion of a series-parallel circuit having resistances connected in parallel, use _____-circuit laws.

- SERIES
PARALLEL
- SERIES
- PARALLEL
- SERIES
- PARALLEL

It is possible to determine the current through and the voltage across any particular resistor in a parallel circuit. This is accomplished by determining the current through the particular resistor and then applying Ohm's law to find the voltage across the particular resistor.

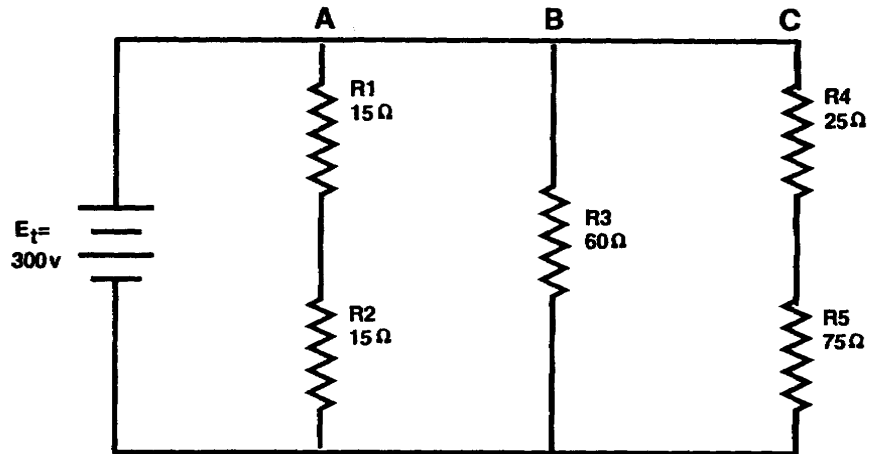

In the diagram above, R1 and R2 are in series. The current through R1 will be the same through R2. Since branch A is in parallel with E_t , the voltage across branch A is equal to 300 volts. The total resistance of branch A (R_A) is 30 ohms. The current through branch A is found by using Ohm's law,

$$I_A = \frac{E_{RA}}{R_A}$$

$$= \frac{300 \text{ v}}{30}$$

$$I_A = 10 \text{ a}$$

(Continued)

The current through R1 is the same as that through R2 (branch current); therefore, I_{R1} is equal to I_A ,

$$I_{R1} = I_{R2} = I_A$$

$$I_A = 10 \text{ a}$$

$$I_{R1} = I_{R2} = 10 \text{ a}$$

a

Notice that the additional branches placed in parallel with branch A do not affect the current through branch A.

The voltage drop across R1 is

$$E_{R1} = I_{R1} \times R_1$$

$$= 10 \text{ a} \times 15$$

$$E_{R1} = 150 \text{ V}$$

It is imperative that the current through the particular resistor under consideration be used in determining the voltage across the resistor. Total circuit current exceeds any resistor current and cannot be used in finding a particular resistor voltage.

The method described above may be used to find the current through and the voltage across any particular resistor in a parallel circuit.

(Continued)

Find the voltage drop across R4 (E_{R4}) and the current through R4 (I_{R4}) in the circuit below.

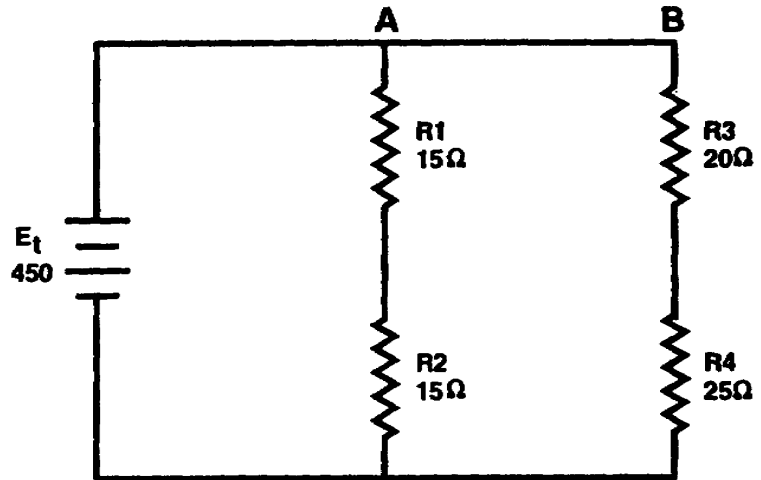

$$E_{R4} = \underline{\hspace{2cm}}$$

$$I_{R4} = \underline{\hspace{2cm}}$$

$$E_{R4} = 250 \text{ V}$$

$$I_{R4} = 10 \text{ a}$$

$$\begin{aligned} \text{SOLUTION: } I_{\text{branchB}} &= \frac{E_t}{R_B} = I_{R4} \\ &= \frac{450 \text{ v}}{45} = I_{R4} \end{aligned}$$

$$I_{\text{branchB}} = 10 \text{ a} = I_{R4}$$

$$\begin{aligned} E_{R4} &= I_{R4} \times R_4 \\ &= 10 \text{ a} \times 25 \end{aligned}$$

$$E_{R4} = 250 \text{ V}$$

PART B

PARALLEL CIRCUITS CONNECTED IN SERIES

The circuit below consists of two parallel circuits connected in series.

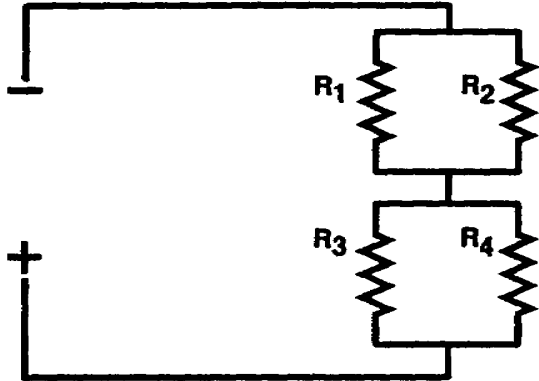

Resistances R_1 and R_2 form one parallel network.

Resistances R_3 and R_4 form one parallel network.

The parallel network R_1 and R_2 and the parallel network R_3 and R_4 are connected in

_____ .

SERIES

Draw connecting lines between the following components to form two parallel circuits connected in series.

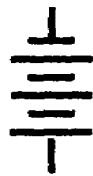

There are many combination of parallel circuits connected in series.

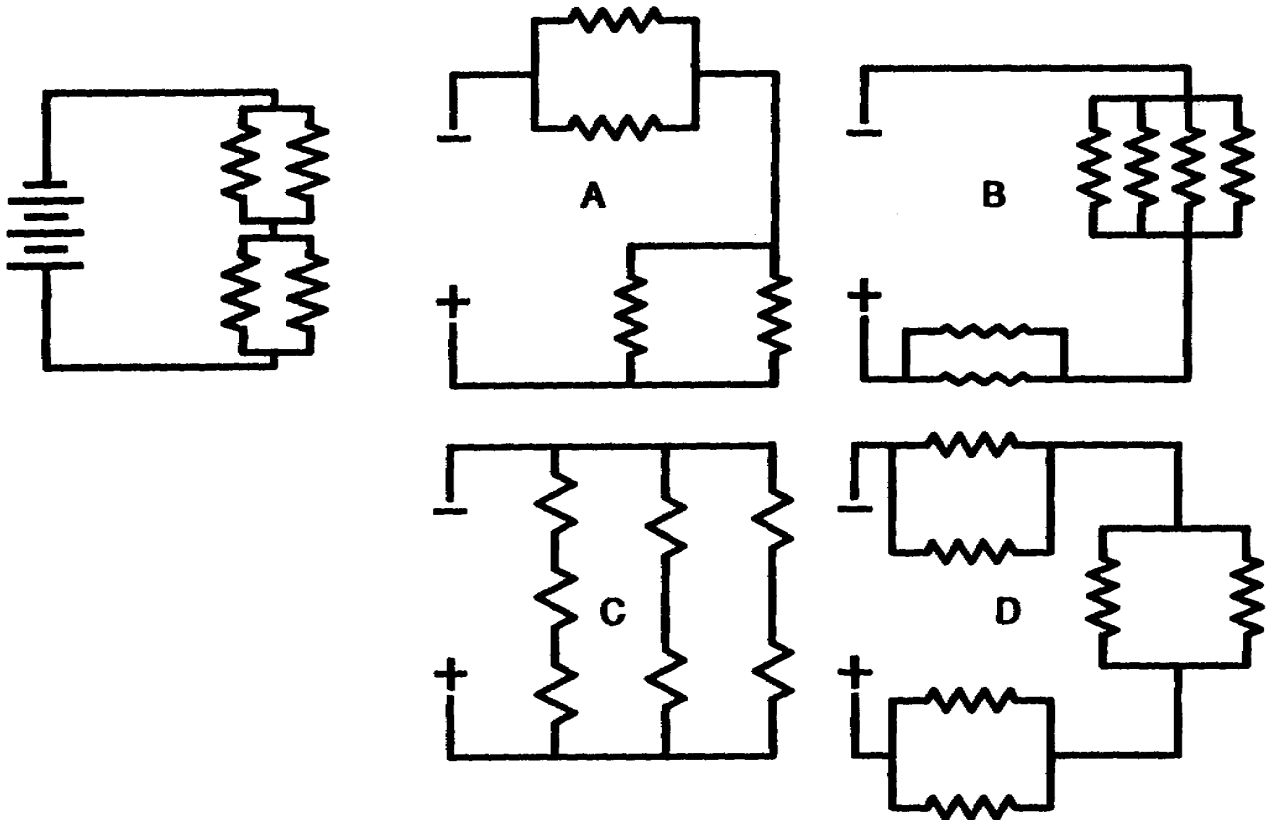

Which of the circuits above are combinations of parallel circuits connected in series?

- A
- B
- D

Draw connecting lines between the following components to form two parallel circuits connected in series.

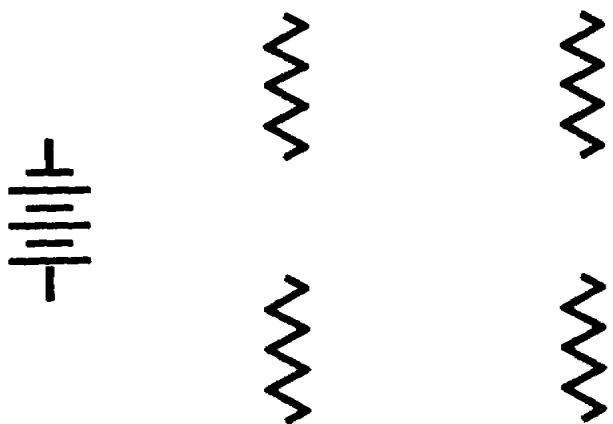

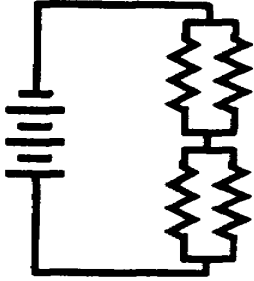

Solving problems with parallel circuits connected in series is made easier by drawing simplified circuits. Remember, when working with resistances connected in parallel, use parallel-circuit laws; and when working with resistances connected in series, use series-circuit laws.

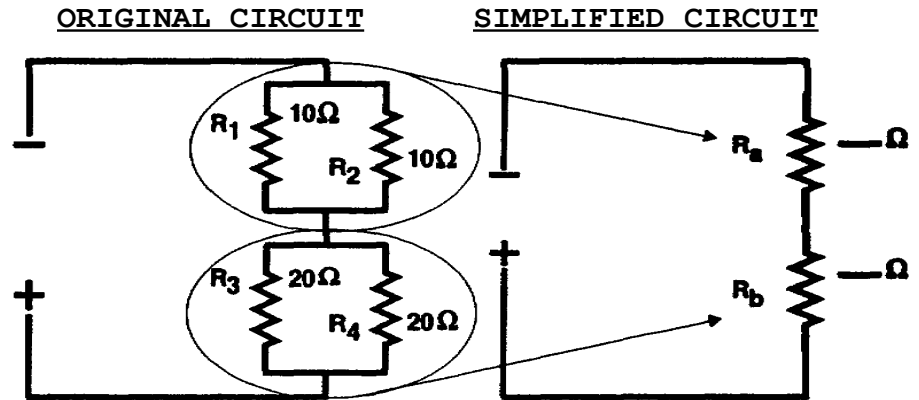

Figure A

Figure B

NOTE: The simplified circuit is a series circuit; therefore, R_t is found by adding the values of R_a and R_b (series-circuit law for total resistance).

- a. The circuit in figure A consists of _____ parallel circuits connected in series.
- b. R_a (figure B) represents the combined value of the parallel network of which resistances? _____
- c. R_b (figure B) represents the combined value of the parallel network of which resistances? _____
- d. What is the value of R_a ? _____
- e. What is the value of R_b ? _____
- f. $R_t =$ _____ ohms

- a. TWO
- b. R_1, R_2
- c. R_3, R_4
- d. 5 OHMS
- e. 10 OHMS
- f. 15 OHMS

Find the total resistance of the original circuit below by:

- a. Finding the total resistance of the parallel network of R_1 and R_2 . Represent this in the simplified circuit as R_a .
- b. Finding total resistance of the parallel network of R_3 and R_4 . Represent this in the simplified circuit as R_b .
- c. Totaling the values of R_a and R_b to get R_t .

ORIGINAL CIRCUIT

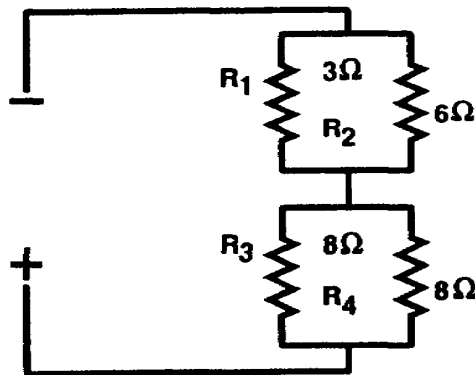

SIMPLIFIED CIRCUIT

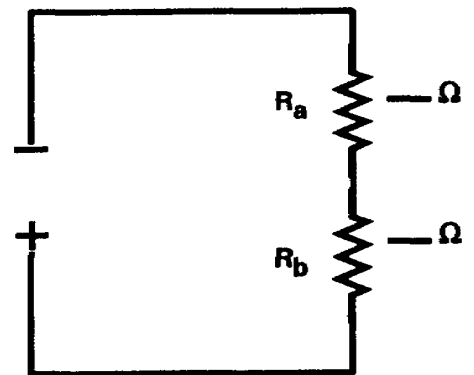

$R_a =$ _____ ohms
 $R_b =$ _____ ohms
 $R_t =$ _____ ohms

$$R_a = 2 \text{ OHMS}$$

$$R_b = 4 \text{ OHMS}$$

$$R_t = 6 \text{ OHMS}$$

This illustration shows current flow through a parallel circuit connected in series.

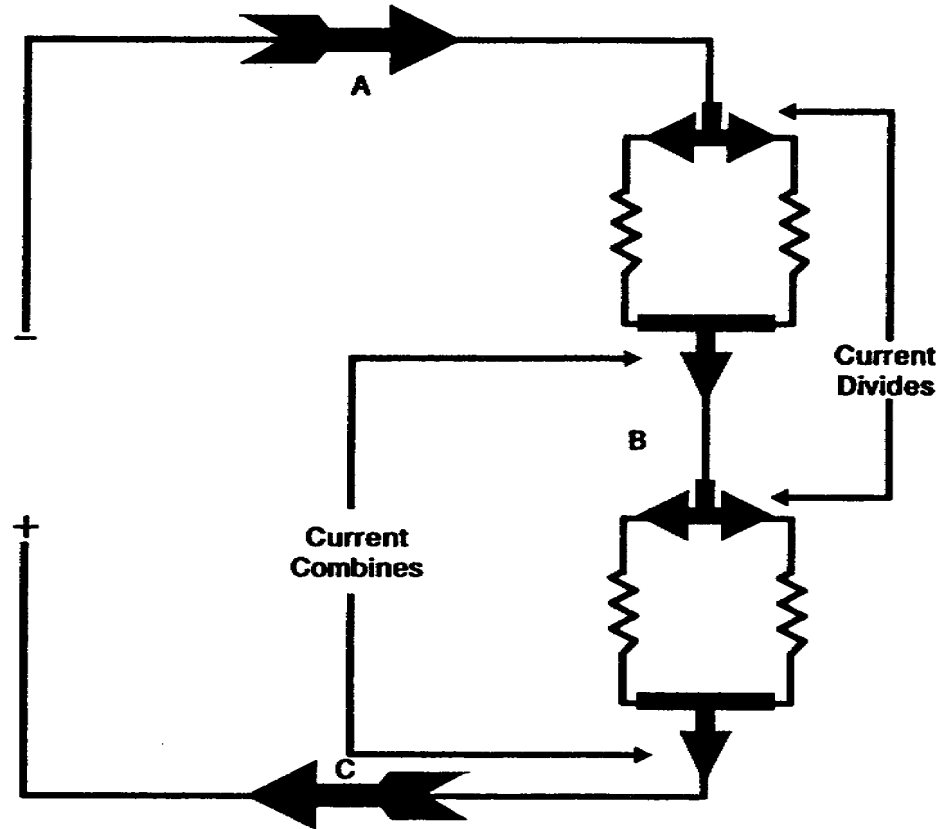

At what points can total current be measured in the circuit above?

- a. Points A and B only.
- b. Points A and C only.
- c. Points C and B only.
- d. Points A, B, and C.

d.

Total current is equal to the total voltage divided by the total resistance. To solve for I_t in the circuit below:

a. Solve for the value of R_a and R_b .

b. Solve for R_t .

c. Divide E_t by R_t to get I_t .

E_t is the source voltage.

ORIGINAL CIRCUIT

SIMPLIFIED CIRCUIT

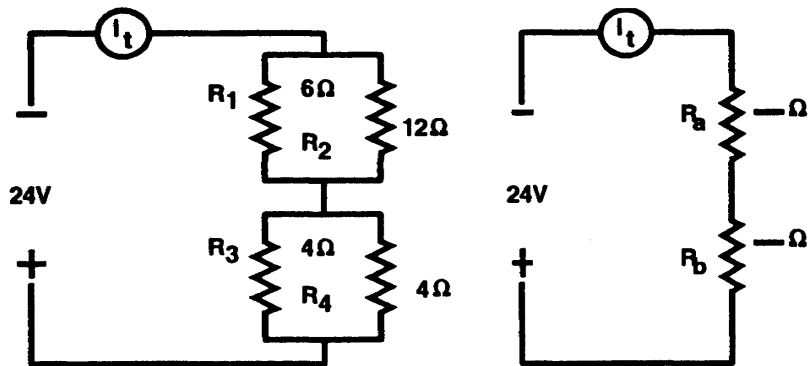

$$R_t = \underline{\hspace{2cm}} \text{ ohms}$$
$$I_t = \underline{\hspace{2cm}} \text{ amps.}$$

$R_t = 6 \text{ OHMS}$
 $I_t = 4 \text{ AMPS}$

Solve for the values of R_t and I_t .

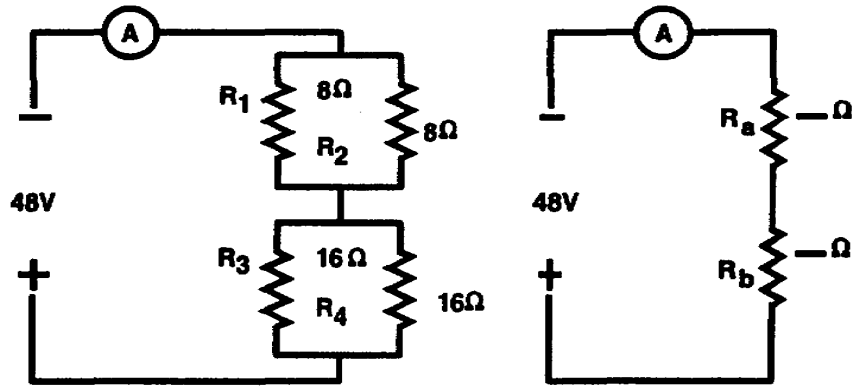

$R_t = \underline{\hspace{2cm}}$ ohms
 $I_t = \underline{\hspace{2cm}}$ amps.

$R_t = 12 \text{ OHMS}$
 $I_t = 4 \text{ AMPS.}$

Draw connecting lines between the following components to form two parallel circuits connected in series.

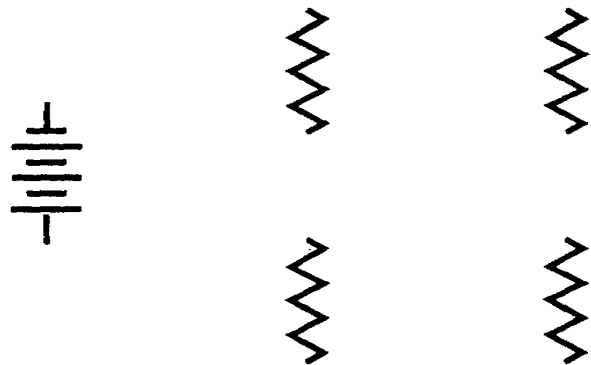

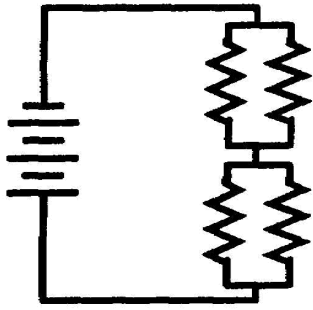

The total voltage in a circuit is equal to total current multiplied by total resistance ($E_t = I_t \times R_t$).

In the circuit below, I_t equals 6 amps. Find total resistance (R_t) and source voltage (E_t).

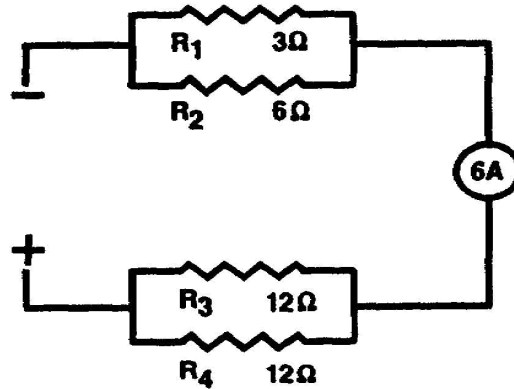

$R_t = \underline{\hspace{2cm}}$ ohms
 $E_t = \underline{\hspace{2cm}}$ volts

$R_t = 8 \text{ OHMS}$

$E_t = 48 \text{ VOLTS}$

Solve for the value of E_t in the circuit below.

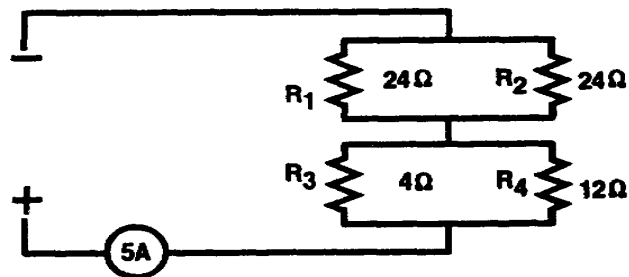

$E_t = \underline{\hspace{2cm}}$ volts

$$E_t = 75 \text{ VOLTS}$$

In a series-parallel circuit with the parallel circuits connected in series, total voltage (E_t) is equal to the sum of the voltage drops across each parallel network.

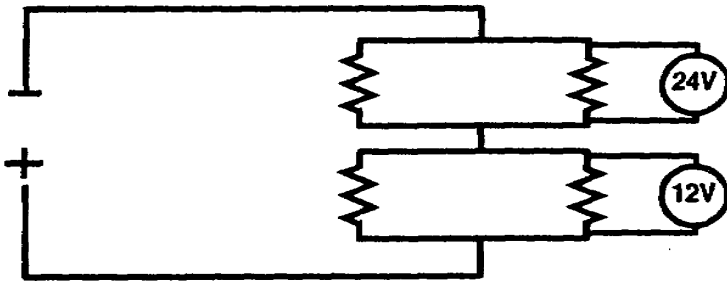

The total voltage (E_t) of the circuit above is _____ volts.

36

The voltage across each branch of a parallel network is the same.

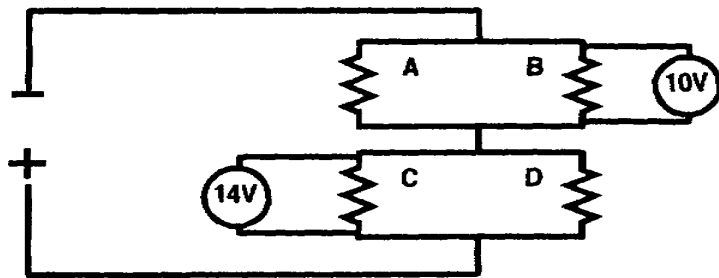

In the illustration above,

- voltage across branch A is _____ volts.
- voltage across branch D is _____ volts.
- total voltage is _____ volts.

- a. 10 VOLTS
- b. 14 VOLTS
- c. 24 VOLTS

Determine the total voltage of the circuit below.

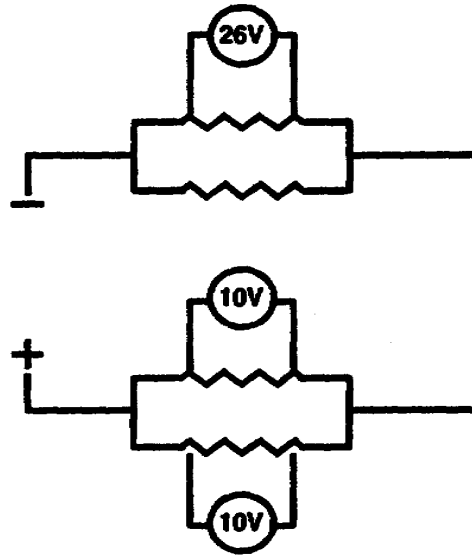

$E_t = \underline{\hspace{2cm}}$ volts

$E_t = 36$ VOLTS

Solve for the total resistance (R_t) of the circuit below.

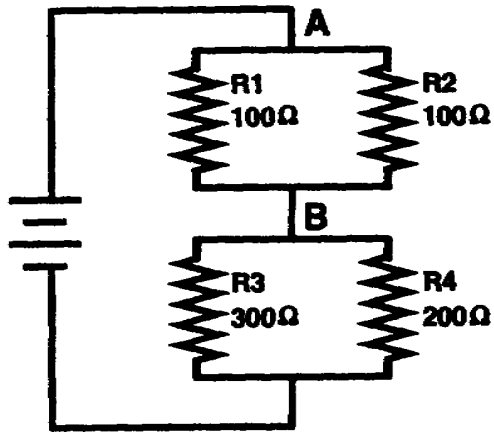

$R_t =$ _____

$R_t = 170 \text{ OHMS.}$

To solve for the current through any resistor in a circuit containing parallel circuits connected in series, calculate the voltage across the resistor, and then apply Ohm's law to determine the current through the resistor.

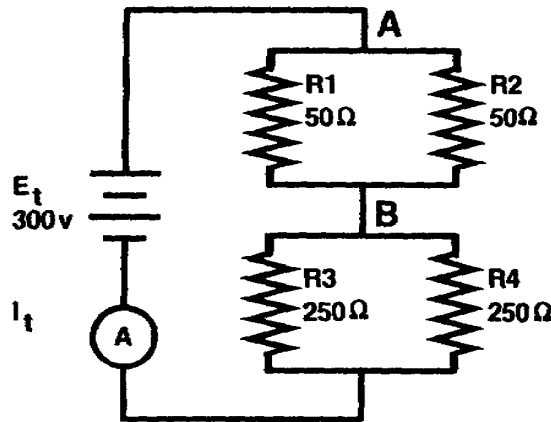

Figure a

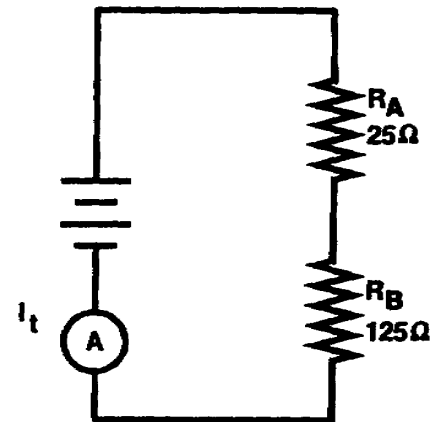

Figure b

The simplified diagram is used to determine the voltage across each resistor. R3 and R4 are in parallel, and the voltage across R4 is equal to the voltage across R3. Since R_B in the simplified diagram represents the parallel combination of R3 and R4, the voltage across R_B is equal to the voltage across R3 and R4. Solving for the voltage,

$$R_t = R_A + R_B = 150$$

$$I_t = \frac{E_t}{R_t}$$

$$I_t = \frac{300 \text{ v}}{150} = 2 \text{ a}$$

(Continued)

$$\begin{aligned} E_{RB} &= R_B \times I_t \\ &= 125 \times 2 \text{ a} \end{aligned}$$

$$E_{RB} = 250 \text{ v}$$

Therefore, $E_{R3} = 250 \text{ v}$

$$E_{R4} = 250 \text{ v}$$

When the voltage across a resistor is known, the current through the resistor is determined by using Ohm's law. The voltage across R4 was calculated to be 250 v. To compute the current through R4, insert the two known values into the equation for Ohm's law.

$$\begin{aligned} I_{R4} &= \frac{E_{R4}}{R_4} \\ &= \frac{250 \text{ V}}{250} \end{aligned}$$

$$I_{R4} = 1 \text{ a}$$

Note that the current through R4 is less than I_t . Since current divides between R3 and R4, each individual current must be less than I_t . In fact, the sum of I_{R3} plus I_{R4} is equal to I_t .

(Continued)

Solve for the voltage drop across R4 (E_{R4}) and the current through R4 (I_{R4}).

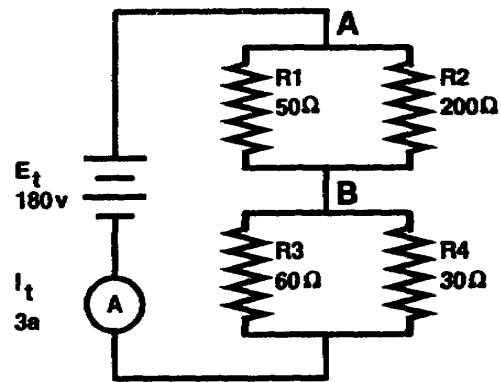

$E_{R4} =$ _____

$I_{R4} =$ _____

$$E_{R4} = 60 \text{ v}$$

(Continued)

$$I_{R4} = 2 \text{ a}$$

SOLUTION: $E_{R4} = E_{RB}$

$$E_{RB} = I_t \times R_B$$

$$= 3 \text{ a} \times 20$$

$$E_{RB} = 60 \text{ v} = E_{R4}$$

$$I_{R4} = \frac{E_{R4}}{R_4}$$
$$= \frac{60 \text{ v}}{30}$$

$$I_{R4} = 2 \text{ a}$$

Solve for total current (I_t) in the circuit below.

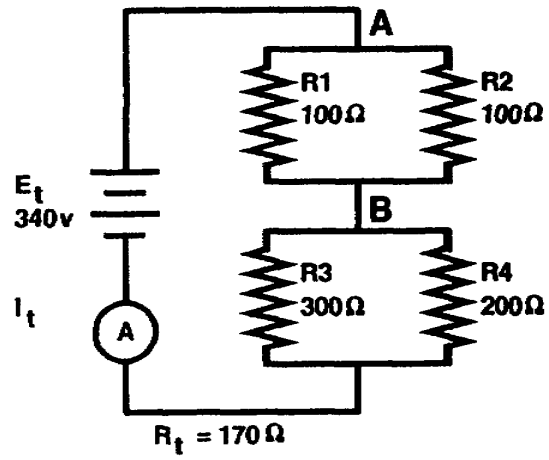

$I_t =$ _____

$I_t = 2\text{ a}$