**LOCOMOTIVE, DIESEL-ELECTRIC,
56-1/2-INCH GAGE, 80-TON, 670 HP,
0-4-4-0 WHEEL,
MODEL B-B- 160/160-4GE747-A
NSN 2210-01-158-2980**

References: TM 55-2210-224-12, FSC C9 100 1L

Intervals (on-condition or hard time) and the related man-hour times are based on normal operation. The man-hour time specified is the time you need to do all the service prescribed for a particular interval. On-condition (OC) oil sample intervals shall be applied unless changed by Joint Oil Analysis Program (JOAP) laboratory. Change the hard time interval if your lubricants are contaminated or if you are operating the equipment under adverse operating conditions including longer-than-usual operating hours.

The hard time interval may be extended during periods of low activity. If extended, adequate preservation precautions must be taken. Hard time intervals will be applied in the event JOAP laboratory support is not available.

WARNING

Dry-Cleaning fluid is flammable. Do not use near a flame or excessive heat. Use only with adequate ventilation. Avoid prolonged breathing of vapors and minimize skin contact.

Clean fittings before lubricating. Clean parts and around filler holes with dry-cleaning SOLVENT (SD), type II or equivalent. Dry before lubricating.

Lubricate points indicated by dotted arrow shaft on both sides of equipment.

Lubricate after washing.

Normally drain crankcase when hot. Fill and check level.

The lowest level of maintenance authorized to lubricate a point is indicated by one of the following: (C) Operator/Crew, (0) Unit Maintenance, or (F) Intermediate Direct Support Maintenance.

You can help improve this publication. If you find any mistakes or if you know of a way to improve the procedures, please let us know.

Your letter or DA Form 2028 (Recommended Changes to Publications and Blank Forms) should be mailed directly to: Commander, US Army Troop Support Command, ATTN: AMSTR-MCTS, 4300 Goodfellow Blvd, St. Louis, MO 63120-1798. A reply will be furnished to you.

TOTAL MAN-HR		TOTAL MAN-HR	
INTERVAL	MAN-HR	INTERVAL	MAN-HR
D	1.0	S	0.2
M	2.0	B	10.0
Q	1.5		

LUBRICANT · INTERVAL

Engine Oil Dipstick Gage (C)
(1 each engine.) (Check and maintain to high level mark.)

OE/
HDO

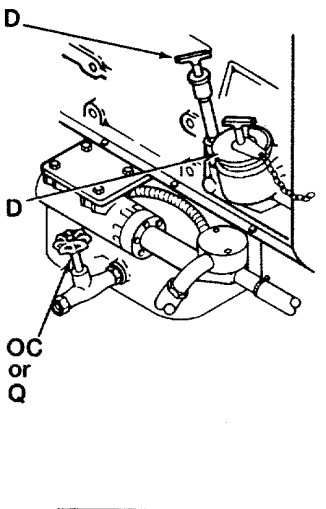

Engine Crankcase Fill (O)
(1 each engine.) (Add oil as needed to maintain at high level mark.)

OE/
HDO

Engine Crankcase Drain (O)
(1 each engine.) (Open drain valve and drain oil.)
(See notes 3, 4, and 5.)

Reverser Air Cylinder (O)
(See note 10.)

GPS

Reverser (O)
(Apply few drops lubricant to oilite bushings.)

LO

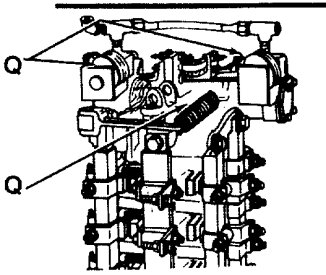

Battery Terminals (O)
(Clean off corrosion and apply light coat of grease.)

GAA

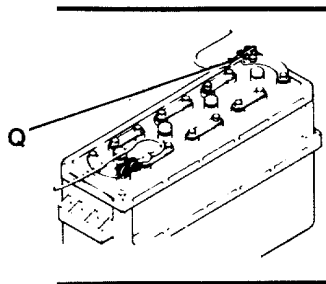

Truck Centerplates (F)
(1 each truck)
(see note 6.)

DD

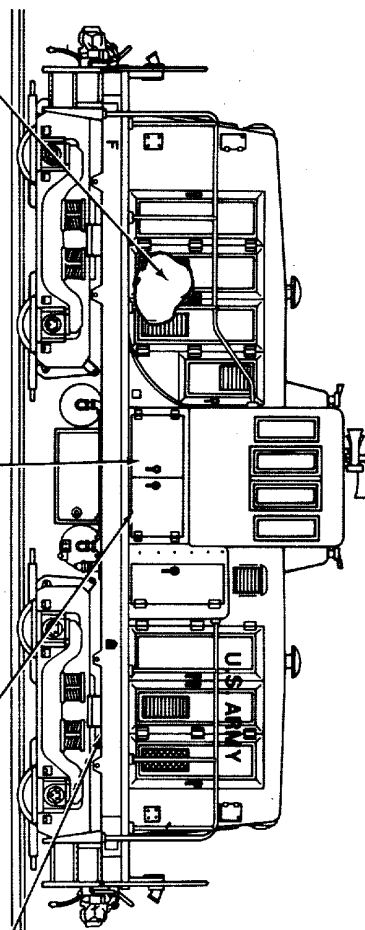
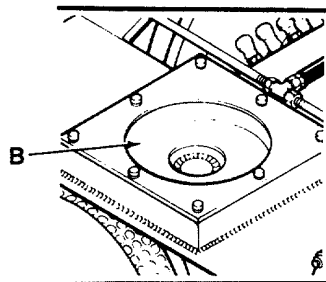

Left Side

LUBRICANT · INTERVAL

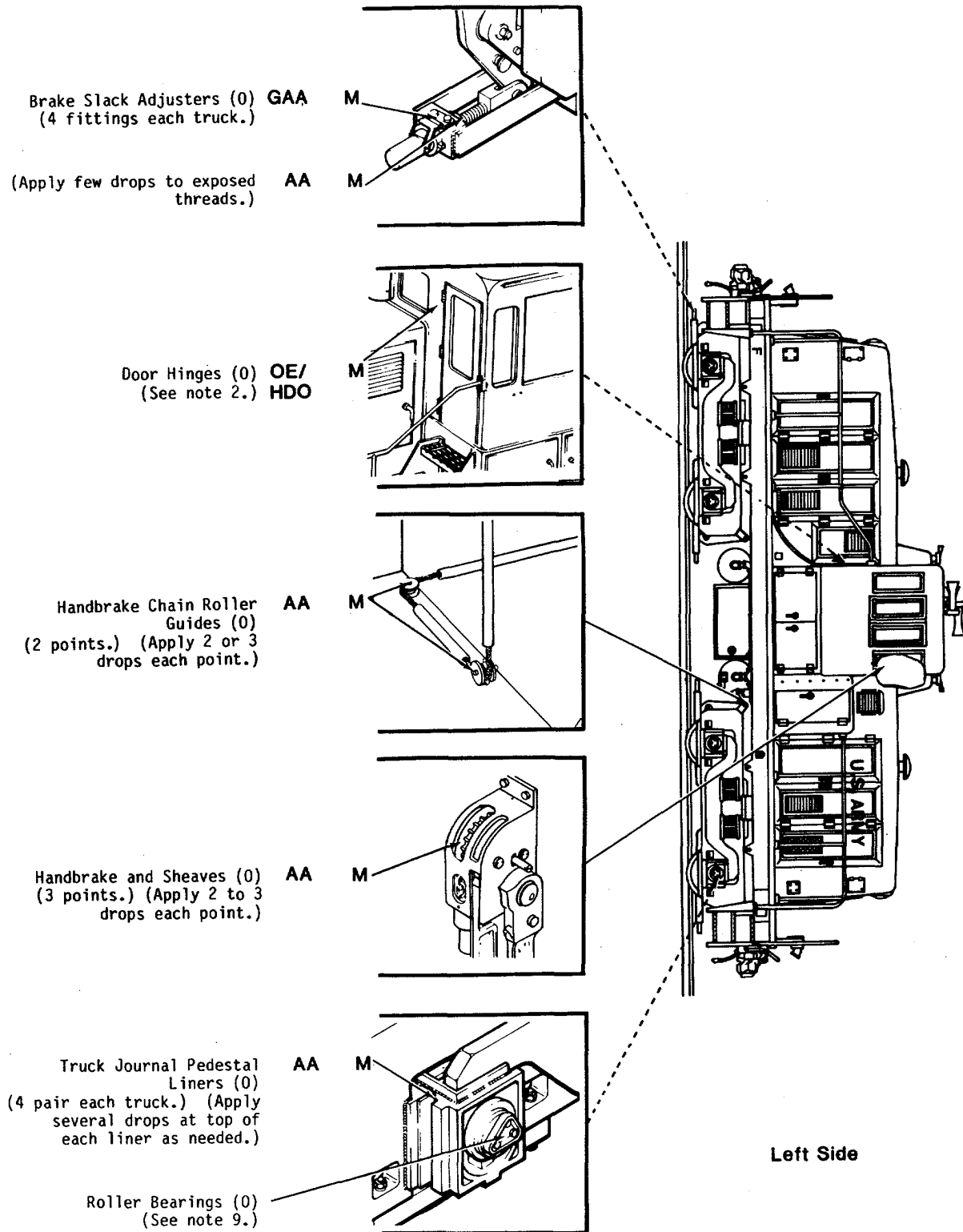

INTERVAL · LUBRICANT

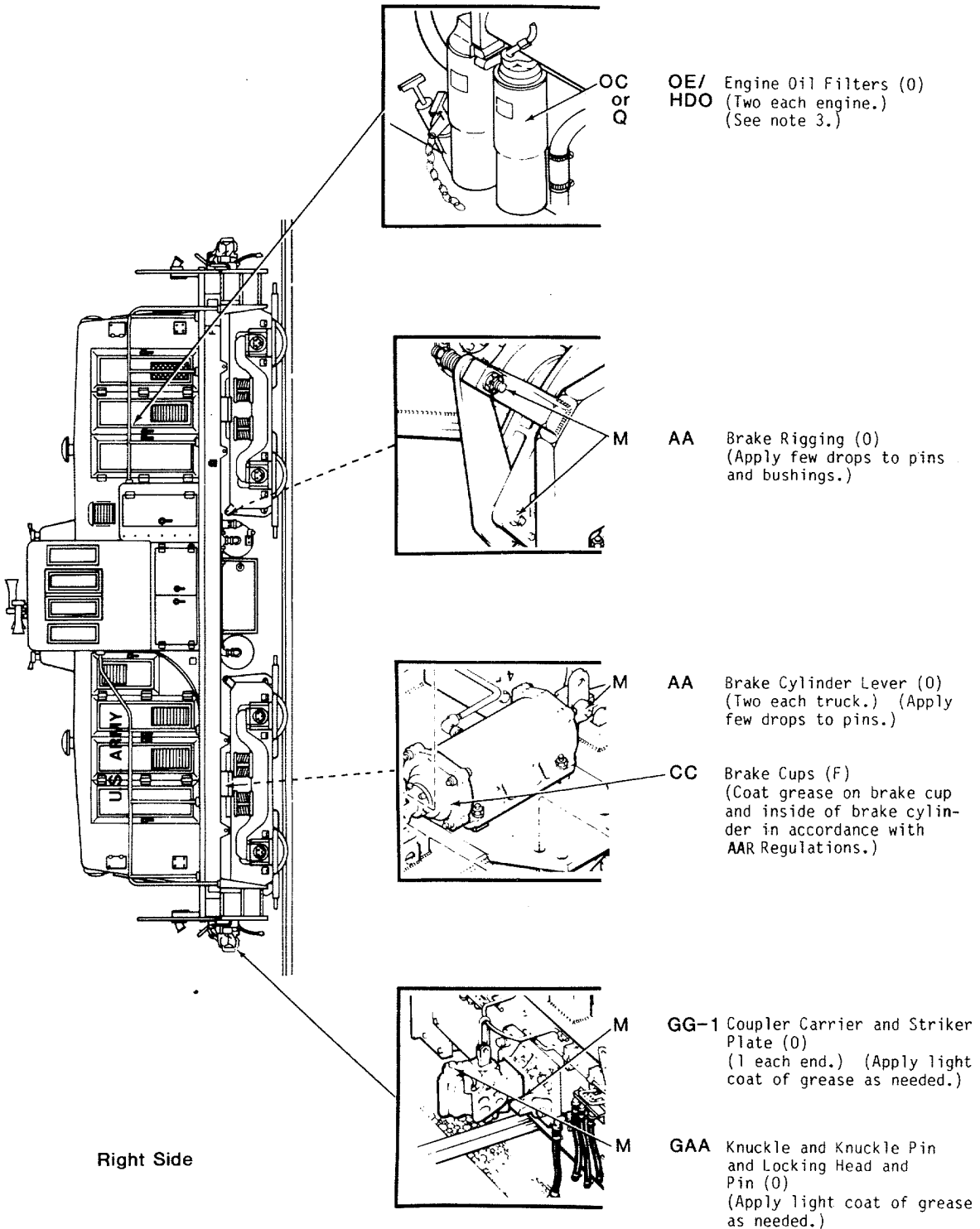

INTERVAL · LUBRICANT

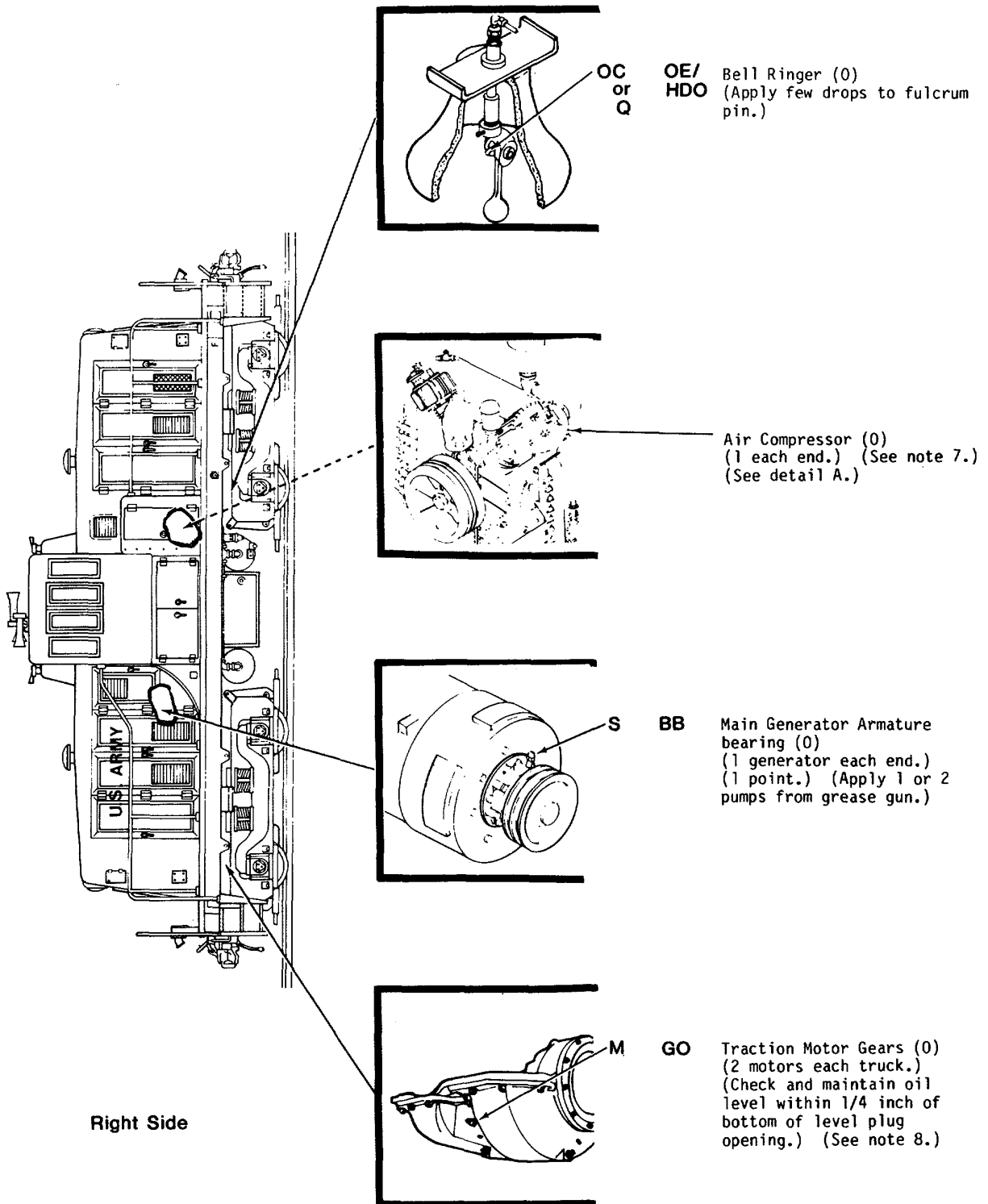

LUBRICANT · INTERVAL

INTERVAL · LUBRICANT

Air Intake Filter (0)
(Remove, clean, and immerse in oil and drain off excess and install.)

Crankcase Cover Plate (0)
(At oil change, remove and clean pump screen and sludge from bottom.)
(Replace plate.)

Crankcase Drain (0) **OE/HDO**
(Drain and refill to correct level.)

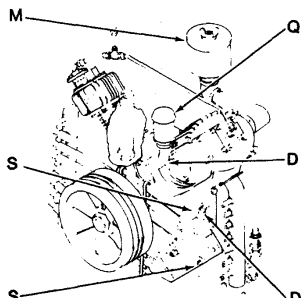

Crankcase Breather (0)
(Remove, clean, and replace.)

OE/HDO Oil Filler (C)
(Add oil as needed to maintain oil level.)

OE/HDO Oil Level Dipstick Gauge (C)
(Check daily, maintain level to FULL mark.)

DETAIL A
AIR COMPRESSOR

- KEY -

LUBRICANTS		CAPACITY	EXPECTED TEMPERATURES		
			ABOVE +32°F (ABOVE 0°C)	+40°F TO 10°F (+4°C TO -12°C)	0°F TO -65°F (-18°C TO -54°C)
OE/HDO (MIL-L-2104D)	LUBRICATING OIL, Engine				
	Engine Crankcase	10.5 gal (39.7 L)	OE/HDO 15W-40W	OE/HDO 15W-40W	OEA
OE/HDO (MIL-L-2104D)	Air Compressor Crankcase	7.5 qt (7.1 L)	OE/HDO 30	OE/HDO 10	OEA
OEA (MIL-H-46167)	LUBRICATING OIL, Engine (Arctic)				OEA
GO (MIL-L-2105)	LUBRICATING OIL, Gear, Multipurpose				
	Traction Motor Gearcase	22 qt (20.8 L)	140	140	90
GAA (MIL-G-10924)	GREASE, Automotive and Artillery		ALL TEMPERATURES		
CC (AAR-M-914-70)	GREASE, Brake Cylinder				
GG-1 (VV-G-671)	GREASE, Graphite				
GPS (MIL-G-4343)	GREASE, Pneumatic System				
BB (Shell-RA 71005)	GREASE, Roller and Ball Bearing				
DD (Shell 72777)	LUBRICANT, Graphite				
LO (VV-L-820)	LUBRICATING OIL, General-Purpose				
AA (TEXHO 57-40W)	LUBRICATING OIL, Railway Car				

For arctic operation, refer to FM 9-207

INTERVALS					
Intervals given are for normal operation					
D-Daily (10 hr)	M-Monthly (100 hr)	Q-Quarterly (3 months) (250 hr)	S-Semiannually (6 months) (500 hr)	A-Annually (12 months) (1000 hr)	B-Biennially (24 months) (2000 hr)

NOTES:

1. FOR OPERATION OF EQUIPMENT IN PROTRACTED COLD TEMPERATURES BELOW -40F (-200C). Remove lubricants prescribed in the key for temperatures above -4°F (-20°C). Clean parts with dry-cleaning SOLVENT. Lubricate with lubricants specified in the key for temperatures 0 to -65°F (-18 to -540C).

2. OIL CAN POINTS. Monthly lubricate all exterior hinges, latches, pins, clevises, springs, and exposed threaded surfaces with OE/HDO oil, excepting similar parts requiring other lubrication as shown on charts.

3. ENGINE OIL FILTERS, ORAINS, AND STRAINERS. Oil filter replacement interval shall align with on-condition JOAP or hard time oil change requirements. See notes 4 and 5. At oil change, drain and clean engine lube oil filters, strainers, housings, sump pans, and interior of crankcase. Drain and dry parts. Replace filter elements and replenish oil supply with approximately 10.5 gallons of engine oil OE/HDO. Fill to high level mark on dipstick. Check engine oil drains, filters, valve covers, and filter strainer housing seals for tightness. Start and run engine. Replenish oil supply to high level mark.

4. ENGINE OIL. A sample of the oil shall be sent to a JOAP laboratory for analysis at an interval of 25 hours or 30 days. Refer to AR 700-132 for sampling requirements.

5. JOAP LABORATORY SUPPORT. When JOAP laboratory support is not available, drain and refill crankcase oil at 500 hours.

6. TRUCK CENTERPLATE. When condition of graphite lubricant indicates, replace lubricator.

7. AIR COMPRESSOR. Semi-annually drain and refill. Bring to FULL mark on compressor oil level dipstick gage. Operate compressor for 5 minutes, check for leaks, recheck oil level, and bring to proper level. Clean strainer.

8. TRACTION MOTOR GEARS. Annually drain oil from gear unit, remove oil pan, and clean out old oil and sludge. Fill with GO oil to within 1/4 inch of oil level plug.

9. ROLLER BEARINGS. No field lubrication. If end cap is equipped with a lubricant fitting, remove and replace with a nonremovable plug.

10. REVERSER AIR CYLINDERS (2 Cylinders). Remove pistons annually, clean, apply a light coat of grease GPS to cylinder walls and piston packing cup.

Copy of this Lubrication Order will remain with the equipment at all times; instructions contained herein are mandatory.

By Order of the Secretary of the Army:

CARL E. VUONO
General, United States Army
Chief of Staff

OFFICIAL:

R. L. DILWORTH
Brigadier General, United States Army
The Adjutant General

DISTRIBUTION:

To be distributed in accordance with DA Form 12-25A, Operator and Unit Maintenance Requirements for Locomotive, 80-Ton, Mode1 112-5708

RECOMMENDED CHANGES TO EQUIPMENT TECHNICAL PUBLICATIONS



THEN...JOT DOWN THE
DOPE ABOUT IT ON THIS FORM.
CAREFULLY TEAR IT OUT, FOLD IT
AND DROP IT IN THE MAIL.

SOMETHING WRONG WITH PUBLICATION

FROM: (PRINT YOUR UNIT'S COMPLETE ADDRESS)

DATE SENT

PUBLICATION NUMBER

PUBLICATION DATE

PUBLICATION TITLE

BE EXACT PIN-POINT WHERE IT IS

PAGE NO.	PARA-GRAPH	FIGURE NO.	TABLE NO.
----------	------------	------------	-----------

IN THIS SPACE, TELL WHAT IS WRONG AND WHAT SHOULD BE DONE ABOUT IT.

PRINTED NAME, GRADE OR TITLE AND TELEPHONE NUMBER

SIGN HERE

LO 55-2210-224-12

PIN: 062284-000