

CARPENTRY III

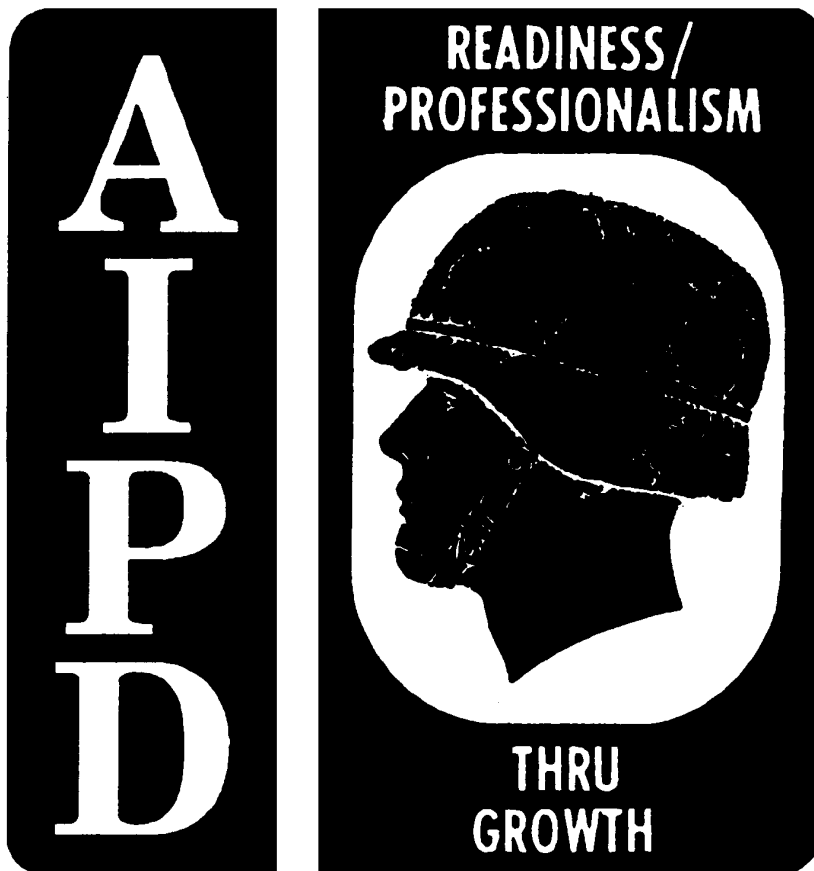

THE ARMY INSTITUTE FOR PROFESSIONAL DEVELOPMENT

ARMY CORRESPONDENCE COURSE PROGRAM

INTRODUCTION

This subcourse, 533, concludes the instruction on carpentry. It discusses the requirements for competent cabinet work, explaining the kinds and selections of woods, the classification and uses of woodworking joints, and the standards for their employment. The selection of materials for constructing wooden articles, the assembling of parts into units, and the steps taken in a final inspection of completed work are presented in sequence.

This subcourse consists of three lessons

- Lesson
1. Cabinetwork.
 2. Prefabricated Buildings.
 3. Heavy Timber Construction.

Eleven credit hours are allowed.

You will not be limited as to the number of hours that you spend on the subcourse, any lesson,
Text furnished: Memorandum 533.

*****IMPORTANT NOTICE*****

THE PASSING SCORE FOR ALL ACCP MATERIAL IS NOW 70%

PLEASE DISREGARD ALL REFERENCES TO THE 75% REQUIREMENT.

LESSON 1

CABINETWORK

CREDIT HOURS-----3

TEXT ASSIGNMENT-----Study chapter 1 in Memorandum 533.

LESSON OBJECTIVE-----To teach you how to identify different types of wood and how to select and use each in cabinetmaking.

EXERCISES

Requirement: Solve the following multiple-choice exercises.

1. You are preparing to make a cabinet for the storage of woolen blanket. What wood do you select for the inner surface?

- a. white pine
- b. redwood
- c. cedar
- d. fir

2. What type joint would you select for connecting a crossrail to the side of a cabinet?

- a. lap
- b. dado
- c. grooved
- d. miter

3. What type joint would you use for constructing drawer for cabinets?

- a. lap
- b. dado
- c. miter
- d. mortise

4. You are building a piece of furniture that must be readily "knocked down" or easily dismantled. What type joint do you make?

- a. keyed mortise and tenon
- b. open mortise

- c. blind mortise
- d. through mortise

5. What form of construction would you select for a table?

- a. box
- b. stool
- c. frame
- d. frame-box combination

6. Which wood shows pleasing patterns when quartersawed?

- a. mahogany
- b. walnut
- c. cherry
- d. oak

7. Which of the following joints would you use to fit panels into frames?

- a. grooved
- b. parallel grain
- c. shouldered dado
- d. open mortise and tenon

8. In making a mortise and tenon joint, what determines the thickness of the tenon?

- a. where it is used
- b. how it is fastened
- c. width of material
- d. thickness of material

9. You are fastening large tops of furniture. Regardless of the method that you use, what do you make sure that the selected method does?

- a. allows for shrinking and swelling
- b. uses no dowels
- c. avoids use of fasteners and glue
- d. combined tops have different grain patterns

10. You must build benches for the shuttle bus stops on your post. What kind of wood do you select?

- a. fir
- b. cedar
- c. redwood
- d. white pine

11. You are ready to assemble your wood pieces into an article of furniture. Before putting the pieces into final form, what is the last thing you do?

- a. check each piece for size, shape, and fit
- b. verify sequence of assembly
- c. assure that each piece was milled properly
- d. arrange for use of duplicate pieces

12. What is the highest grade of hard wood?

- a. No. 1 common
- b. first
- c. No. 2 common
- d. select

13. What type of joint is most often used for constructing building frames?

- a. lap
- b. miter
- c. tenon
- d. open mortise

14. What is the maximum diameter of a dowel in inches that you would use on a board 2 inches thick?

- a. 2
- b. 1 1/4
- c. 1
- d. 1/2

15. What wood do you recommend for building a boat?

- a. cedar
- b. redwood
- c. walnut
- d. fir

16. What kind of wood is generally white, has heartwood of reddish brown to dull brown, which sometimes turns to a lavender tinge, and has a pungent odor, bitter taste, and low strength?

- a. oak
- b. fir
- c. redwood
- d. cedar

17. In cabinetmaking what are the determining factors in the wood selected?

- a. strength
- b. heaviness
- c. beauty and finishing qualities
- d. beauty

18. Select the choice that lists four variations of the mortise and tenon joint.

- a. open, through, blind, haunched
- b. open, haunched, miter, grooved
- c. lap, slip, grooved, dado
- d. dovetail, dowel, corner, butt

19. How would you reinforce a plain miter?

- a. add dovetail joint
- b. use a spline
- c. add a panel
- d. add dado housing

20. Why is frame construction preferred over stool construction?

- a. grain runs differently in length and width
- b. dowel joints work well
- c. overcomes shrinkage and swelling
- d. panels cannot shrink

LESSON 2

PREFABRICATED BUILDINGS

CREDIT HOURS-----3

TEXT ASSIGNMENT-----Study chapter 2 of Memorandum 533.

LESSON OBJECTIVE-----To teach you how to erect, supervise, and repair wood and metal prefabricated buildings.

EXERCISES

Requirement. Solve the following multiple-choice exercises.

1. When would you place tile or linoleum on a wooden floor in a prefab building?

- a. if needed for insulation
- b. if underlayment we omitted
- c. if floor is solid and covered with a smooth underlayment
- d. when asphalt materials could be used

2. In erecting a framed prefabricated building which of the following would be your guide?

- a. make rafter spacing same stud spacing
- b. place joints 30 inches on center
- c. cement floor must not be used
- d. place plywood horizontally on side walls

3. Joints are formed by the following parts of a prefab building. Which

of them would you weatherproof with vinyl seal joint?

- a. end-lapped roof panels
- b. flashing and vertical surfaces
- c. vertical joints in exterior walls
- d. vent stacks and roof panels

4. How would you modify a prefabricated building when erecting it in the Arctic?

- a. double floors and insulate the walls and roofs
- b. double number of windows
- c. install central heating
- d. install skirting to extend to ground

5. If you placed copper in contact with each of the metals listed below which one would produce the greatest amount of corrosion as a result of that contact?

- a. iron
- b. aluminum
- c. tin
- d. lead

6. In which of the following climates would you use insulated roof panels on panel wooden prefab buildings?

- a. hot only
- b. cold only
- c. hot and cold
- d. mild and hot

7. What is the length of a bay in a light-steel frame building?

- a. 12 feet
- b. 16 feet
- c. 20 feet
- d. distance between columns along the side walls

8. You are cutting a piece of glass to fit a metal sash. How much shorter must the glass be cut than the sash?

- a. thickness of one glazing clip
- b. thickness of two glazing clips
- c. thickness of one glazing clip plus a putty bed
- d. thickness of two glazing clips plus a putty bed

9. The plywood floor of a standard size quonset hut requires H-shaped floor splines and how many sheets of plywood?

- a. 18
- b. 24
- c. 30
- d. 36

10. Which of the following would you use to prevent the end bays of a light-steel frame building from sagging?

- a. sag rods, purlins, and girts
- b. sag rods and brace rods
- c. siding, roofing, and girts
- d. brace rods, siding, and roofing

11. Why would you use sag rods?

- a. brace columns
- b. keep girts from shifting
- c. prevent panels from shifting
- d. reduce binding at door header

12. What type of fasteners would you use in assembling a quonset hut?

- a. sheet metal screws and channel clips
- b. 2-bars, T-bars, and H-shaped splines
- c. nails, bolts, and screws
- d. J-clips with stove bolts and screws

13. Which of the following metals is most commonly used for the construction of metal prefab buildings?

- a. aluminum
- b. zinc
- c. nickel
- d. copper

14. Which of the following is the standard size in feet for a quonset hut?

- a. 6 x 8
- b. 8 x 16
- c. 16 x 28
- d. 20 x 48

15. What do you use to protect the joints between plywood floor panels?

- a. screws
- b. putty
- c. T-shaped metal strip
- d. H-shaped metal strip

16. Which of the following would you use to fasten wall panels in place in paneled prefabs?

- a. single-head scaffold nails
- b. sag rods
- c. bolts
- d. T-shaped metal strips

17. What are the parts of the floor in a framed wooden prefab building?

- a. flooring, joists, girders
- b. subflooring, struts
- c. purlins, girder, sag rods
- d. frame, joists, girts

18. Where do you install the brace rods in the light-steel frame building?

- a. door track
- b. end bays
- c. floor
- d. roof

19. Why must you use a separator between aluminum siding and steel frames?

- a. gives more strength
- b. prevents corrosion
- c. permits easy dismantling
- d. prevents leakage

20. What holds the glass in place in a metal window frame while putty is being placed?

- a. putty
- b. gutter
- c. sash
- d. glazing clips

LESSON 3

HEAVY TIMBER CONSTRUCTION

CREDIT HOURS-----3

TEXT ASSIGNMENT-----Study chapter 3 of Memorandum 533.

LESSON OBJECTIVE-----To teach you the fundamental principles of constructing and maintaining warehouse loading docks and waterfront structures.

EXERCISES

Requirement: Solve the following multiple-choice exercises.

1. How would you space the piles supporting a pier?

- a. 30 feet apart, braced along the sides
- b. 18 feet apart, center-to-center
- c. 6 feet apart, center-to-center, in the other direction
- d. 6 to 10 feet apart, center-to-center, in one direction, and 5 feet apart, center-to-center, in the other direction

2. What is the minimum thickness in inches for the decking of a loading platform?

- a. 1
- b. 2
- c. 3
- d. 4

3. If you were fastening decking that is 3 inches thick, how big a spike would you use?

- a. 5-inch
- b. 6-inch
- c. 7-inch
- d. 8-inch

4. Which one of the following tool should be used by two men together?

- a. timber carrier
- b. pike pole
- c. cant hook
- d. peavy

5. What generally causes timber decay on docks?

- a. fungi
- b. termites
- c. marine borers
- d. atmospheric conditions

6. In constructing a pier, which one of the following would you secure to the caps?

- a. joists
- b. girders
- c. purlins
- d. sills

7. Wharf girders are secured with drift pins, as are pier girders. Where would you secure these wharf girders?

- a. directly on the bearing piles
- b. on caps that are secured to the piles

- c. directly on the joist carrying the decking
- d. on 1 x 16 inch timbers set on the piles

8. Which of the following piles supports the pier framework and decking?

- a. bearing
- b. mooring
- c. fender
- d. dolphin

9. When you construct a wharf, which of the following would enable you to decide on the length of the piles?

- a. depth of the water and condition of the bottom
- b. expected load and type of equipment
- c. type of framework and decking
- d. expected load plus depth of water in feet

10. You have received a loading dock plan that calls for 3 x 6 inch joist spaced 16 inches on center. You doubt that the joists have enough supporting strength. What do you do?

- a. reduce joist spacing to 12 inches
- b. use heavier joists and reduce spacing
- c. use heavier joists with the stated spacing
- d. reduce joist spacing to 14 inches

11. You have followed all directions and instructions pertaining to termite control, but termite colonies still accumulate. What do you do now?

- a. poison the soil
- b. treat the wood
- c. consult an entomologist
- d. construct termite shields

12. What is the most economical material to use in the construction of wharves and quays?

- a. timber
- b. concrete
- c. steel
- d. steel and concrete

13. Which of these waterfront structures would you erect perpendicular to the shore line?

- a. wharf
- b. pier
- c. bulkhead
- d. retaining wall

14. The columns used for a loading dock foundation are spaced according to the weight they are to carry. How many feet apart are they usually spaced?

- a. 6 to 15
- b. 6 to 10
- c. 5 to 20
- d. 5 to 15

15. What two waterfront structures are constructed parallel to the shore line?

- a. wharves and piers
- b. fenders and dolphins
- c. bits and dolphins
- d. wharves and quays

16. You plan to construct a pier from material that will be economical and easy to work. Which of these do you select?

- a. concrete
- b. steel
- c. reinforced concrete
- d. timber

17. Which of these do you use to protect waterfront structures from moving vessels?

- a. fenders
- b. mooring piles
- c. bearing piles
- d. bulkheads

18. Which of the following special tools would you use to hold timbers while they were being placed?

- a. cant hook
- b. pike pole
- c. peavy
- d. timber carrier

19. Why would you use bearing piles on waterfront structures?

- a. to support framework and decking
- b. to strengthen bulkheads
- c. to protect the structure from moving ships
- d. to permit easier mooring

20. The mooring piles are placed in line with the outside row of bearing piles, and braced along the outside row of the bearing piles. Approximately how far apart in feet would you space the mooring piles?

- a. 10
- b. 20
- c. 25
- d. 30



MEMORANDUM 533

CARPENTRY III (SPECIALIZED CARPENTRY)

U.S. ARMY ENGINEER SCHOOL

MOS: 51B20

PAGE INTENTIONALLY LEFT BLANK

CONTENTS

	<i>Page</i>
Preface.....	i
<i>Chapter</i>	
1 CABINETWORK.....	1
2 PREFABRICATED BUILDINGS.....	14
3 HEAVY TIMBER CONSTRUCTION.....	26
4 SAWMILL OPERATION.....	34

Cabinetwork

IN YOUR JOB AS AN Army carpenter, you will build many cabinets. Cabinet building is a precision job that is performed inside a shop, although much of the work is done at the location where the cabinets are to be installed. The cabinets should be well designed, structurally sound, and appealing in appearance. Look at some of the cabinetwork around you or try to recall the appearance of some kitchen cabinets that you have seen. Do they make good use of the available space? Do the doors fit and latch tightly? Are the shelves strong and the joints tight? Do the cabinets look like they were done by a craftsman?

2. This chapter is devoted to the materials used and methods applied to achieve these goals. We will cover the types and characteristics of wood used in cabinetwork. Some of the softwoods are white pine, fir, cedar, and redwood; some of the hardwoods are walnut, mahogany, and oak. Of course, grades and standards of hardwood and plywood will also be covered here.

3. We will discuss some of the joints used in cabinetwork, such as parallel grain joints, right-angle grain joints, grooved joints, miter joints, mortise and tenon joints, dovetail joints, and butt joints. Remember, a good joint is one that is well made and fits properly. The type of cabinet that you will make will be one of three types: frame, stool, or box. A step-by-step procedure will be given in the construction of each of these items.

4. Study each section carefully and try to apply what you learn to all of your cabinetmaking projects.

1. Cabinet Woods

1-1. In cabinetmaking, those characteristics of wood with which we are concerned differ somewhat from those characteristics of wood with which we are concerned when we are dealing with frame construction. For example, in cabinetmaking, beauty and finishing qualities are the determining factors rather than strength.

Many beautiful hardwoods are strong. Being strong and naturally beautiful, they are favored for cabinetwork.

1-2. It is almost impossible to discuss in detail all the woods used in cabinet construction; however, we are primarily concerned with those woods which are in common use.

1-3. In this section we will discuss the types of wood used in cabinetwork and the characteristics of each type. After studying these characteristics, you should be able to identify and select the proper wood for a particular job.

1-4. The most desirable woods for cabinetwork should:

- a. Have the ability to keep their shape without shrinking, warping, or swelling.
- b. Be easily workable with tools and machinery without causing rough surfaces.
- c. Be strong, with suitable grain characteristics that are pleasing to the eye.

1-5. **Softwoods.** Many softwoods are used in cabinetmaking. Among these, white pine is one of the most useful of all. It is also easy to work, because it has a uniform grain and holds its shape well. White pine is soft, light, and of medium strength. It splits easily but holds nails fairly well. It also takes glue well. The grain is not prominent; therefore, it has no particular beauty. For this reason, coupled with its ability to hold paint, it is most often painted.

1-6. Fir comes in three well-known species: Douglas fir, yellow fir, and red fir. Fir is difficult to work with hand tools, because it splits easily. It glues well but will not hold paint; therefore, it is usually treated with a preservative. It is used extensively for making plywoods and in millwork, boatbuilding, and shingle manufacturing.

1-7. Cedar comes in a variety of species; this makes it difficult to, cover each in detail; however, we will discuss some of its general characteristics. The sapwood is generally white, with the heartwood being a reddish brown to

dull brown and sometimes turning to a lavender tinge. Cedar is known for its pungent odor and spicy bitter taste. It is a light, soft wood of low strength and does not bend easily. However, it works well, finishes smoothly, takes paint, and glues well, although it will split easily. Cedar has a high resistance to decay, is uniform in texture, and is very knotty. After it is seasoned, it will keep its shape well. It is used as a liner for closets, cedar chests, etc., because of its moth-repellent action. It is also used for millwork, novelties, and furniture.

1-8. Redwood is a soft, odorless, straight, even-grained softwood, coarse in texture and light in weight. It works well with tools and holds glue and paint exceptionally well. Redwood shrinks very little and keeps its shape well after it is seasoned. It resembles cedar in color but has a much coarser texture. It is used for building construction, millwork, garden furniture, novelties, and shingles.

1-9. **Hardwoods.** Hardwoods are used extensively for fine furniture and cabinets. Their strength, plus beauty and ability to take clear finishes (varnish and lacquer), makes them ideal for the finest products of the cabinetmaker. There are many types of hardwoods; however, we will cover only the principal ones.

1-10. Walnut is one of the finest of cabinet woods, because the grain is porous and varies from straight to irregular. Walnut works well with tools, finishes smoothly, and holds glue and stain well. It is a hard, strong wood and is easily identified by its dark heartwood. It is used extensively for plywoods, veneers, furniture, and millwork.

1-11. Mahogany is not a native wood; therefore, all species are imported. Most varieties come from Central America, Africa, and India. It is a hard, strong wood; however, the hardness can vary with the species. Color can vary in shade, but generally speaking, it is reddish brown. Mahogany has a close, varying grain, causing a pleasing reflection of light. It is used chiefly for fine furniture, plywood panels, veneers, and interior finishes.

1-12. Oak is a very hard, strong wood with two main species: white and red. Unless it is carefully seasoned, it will warp and check; however, once it is worked to a finish it is without rival for strength and beauty. Oak bends excellently, holds nails well, finishes smoothly, and holds glue satisfactorily. The grain is coarse and porous; and when quartersawed, the medullary rays are broad and numerous, making pleasing patterns. It takes stain very well, making beautiful grain contrasts, and is used for interior finishes, flooring, plywood panels, veneers, and

furniture. Oak sometimes is used in boatbuilding where strength is required.

1-13. **Hardwood Grades and Standards.** Because hardwood grading standards are of particular importance in cabinetmaking, we will emphasize this importance by discussing such standards under a separate special heading. These standards are based on the amount of clear, usable lumber in each piece. Material commonly called clear-cutting must have one clear side and the reverse side sound. This means that there must be no rot, shakes, or other features present which might impair the strength of the wood.

1-14. The highest grade of hardwood is termed "first" and the next grade "second." The third grade is termed "select," followed by No. 1, No. 2, and No. 3 common. These grading rules are by no means complete. There are numerous details and special rules for certain species. However, if you keep those specifications mentioned above in your mind, your problems in selecting general hardwoods will be made easier.

1-15. **Plywood.** Today plywood is used for thousands of products, and the average person comes into contact with it every day. It, too, is used extensively in cabinetwork.

1-16. Modern plywood consists of veneers that are fabricated with glues. In simple terms, it consists of three or more layers of thin wood firmly glued together, with the grain direction of the middle layer at right angles to the outer layers. By this means of fabrication, swelling and shrinking is reduced and stability and strength are added, qualities which would not be found in the original material.

1-17. Wood used in cabinetwork consists of a variety of hardwoods, softwoods, and plywood. When selecting materials for cabinets, you should select the type best suited for the job you are doing. That is, don't use the highest grade of lumber or the best grade of plywood to construct a cabinet that is to be used for storage.

1-18. Now that we have discussed some of the woods used in cabinetwork and their characteristics, let's take a look at some of the joints used when constructing a cabinet.

2. Joints Used in Cabinetmaking

2-1. Wood surfaces that are to be glued must be smooth and true; therefore, when you glue wood surfaces, be sure that there are no machine marks, chipped or loosened grain, or other surface irregularities and that you follow the instructions on the glue container. Another important point for you to remember is that a strong joint is a joint where the glue and wood are in

contact over the entire area and that there are no air bubbles or foreign particles between the wood layers.

2-2. A product of the cabinetmaker is no stronger than its weakest joint. However it is well to remember that you need not be a skilled perfectionist to produce a good joint. If you plan your work, visualize the various steps in their proper sequence, and perform these steps to the best of your ability, you can succeed in making joints that fit well and serve their purpose. A strong joint is one that is well fitted.

2-3. Many types of joints are used in woodworking; however, in this section we will discuss only the following classifications pertaining to cabinetmaking:

- Parallel grain joints.
- Right-angle grain joints.
- Lap joints.
- Grooved joints.
- Miter joints.
- Mortise and tenon joints.
- Dovetail joints.
- Butt joints.

2-4. This section will acquaint you with these classifications, the types of joints covered by each, and where they are used, rather than with any detailed descriptions of how each kind of joint is laid out and constructed.

2-5. The selection of a specific type of joint is determined by the following factors:

- a. Working qualities and strength of the material to be used.
- b. Whether the work is on the exterior or on the interior and whether it is a movable or a stationary project.
- c. How the project will be fastened, such as nailed, screwed, glued, or a combination of these.
- d. Whether the grain is parallel or at right angles where the joint is fastened.

e. Whether the fasteners are to be visible or concealed.

2-6. **Classification by Grain Direction.** In our study of joints, let's first consider their classification pertaining to grain direction. By this we mean the length, face, edge, and end of a board.

2-7. *Parallel grain joints.* Parallel grain joints are those in which the grain in the jointed pieces runs in the same direction. There are two types of such joints: (1) Parallel edge grain joints, which are used in joining wood edgewise; and (2) parallel right-angle joints, which are used in joining pieces of wood so that their faces are at right angles and their grain parallel.

2-8. *Right-angle joints.* Right-angle joints are those in which the grain of the woods meet at right angle when they are joined. There are three types of right-angle grain joints: (1) end-to-edge joints, in which the end of one member is fitted to the edge of the other member (see fig. 1, A); (2) oblique joints, where the graining of both members is fitted end to end; and (3) end-to-face joints, where the end grain of one member is joined to the face of the other member (see fig. 1, C). The plain miter joint shown in figure 1, B, is a good example of an oblique right-angle joint.

2-9. **Classification by Construction Detail.** We have described the main classes into which all woodworking joints fall. Now let's study joint classification with regard to construction detail.

2-10. *Lap joints.* The lap joint a simple lap, or halved, joint made by cutting out equal half sections from both members which are to be jointed. There are several variations of the lap joint. When the half sections are cut from the end of the members to be jointed and cross each other at right angles, the joint is known as an end lap joint as shown in figure 2, A. If the members cross each other at right angles in the center, the joint is called a cross lap joint, as

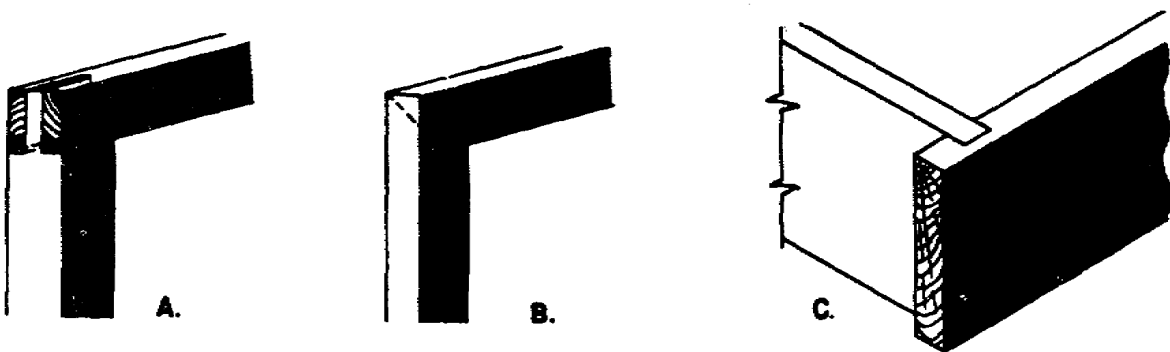

Figure 1. End-to-edge joints.

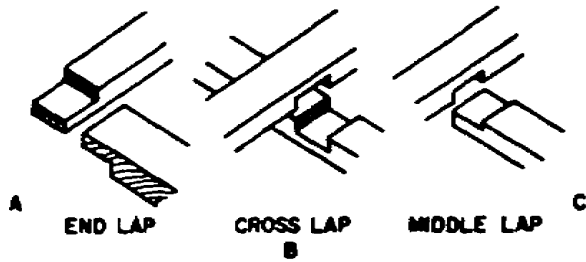

Figure 2. Lap joints.

illustrated in figure 2, B. If one end of a lap joint joins the other in the center, as shown in figure 2, C, the joint is known as a middle lap joint.

2-11. Lap joints are used by the carpenter in framing timbers for sills and girders. Cabinetmakers use lap joints for connecting crossrails to the side of cabinets and for many other types of frames.

2-12. *Grooved joints.* Grooved joints are those which have a groove, or recess, cut into one member, either with the grain or across the grain, into which the edge or end of the other member is fitted. The grooved joint is a familiar joint to the cabinetmaker and has many variations.

2-13. Dado joints are actually grooved joints with the groove running across the grain of the wood. They are used extensively in cabinetwork drawer construction. The dado is a housing, or groove, cut into one member with the other member fitting into this groove. A plain dado is one which extends completely across the board. (See

fig. 3, A.) When the groove, or dado, is not extended completely across, as illustrated in figure 3, B, it is known as a stopped, or blind, dado. A shouldered dado (see fig. 3, C) differs from the

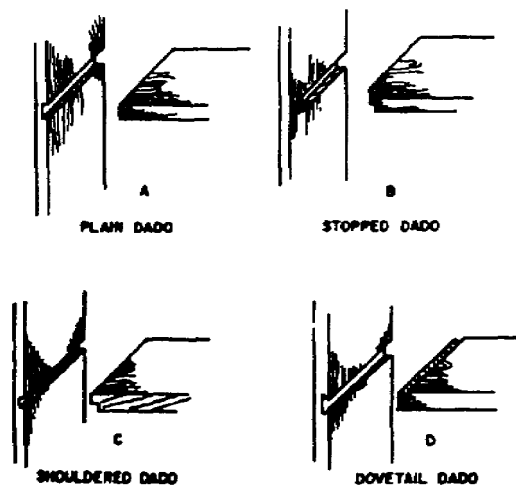

Figure 3. Dado joints.

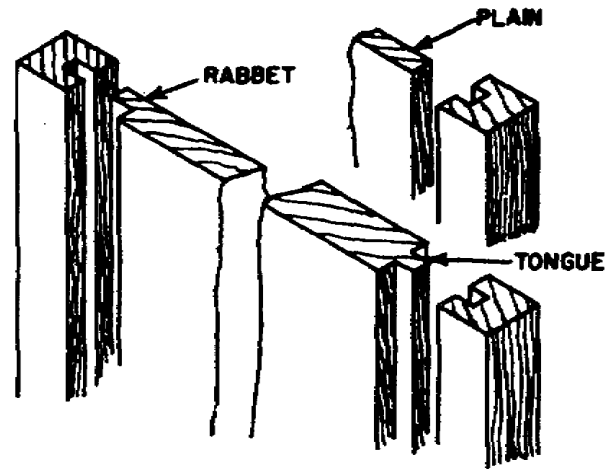

Figure 4. Grooved joints.

plain dado in regard to the horizontal member, which is rabbeted to fit the dado. To counteract strain, a dado joint can be dovetailed, as shown in figure 3, D. Dovetailed dado joints can be constructed in the blind, or stopped, dado style.

2-14. Grooved joints have the groove, or plow as it is sometimes called, running with the grain of the wood. They are used extensively in panel construction. Figure 4 illustrates three methods in which a member can be inserted and fitted into a groove. Grooved joints can be plain or cut with a rabbet or tongue and can be joined with

either glue or nails. However, when a panel is inserted and surrounded by a frame, the panel is made to fit snug but is not glued or nailed. This allows the panel to swell or shrink without breaking the frame. Grooved joints can be cut with the circular saw, using a dado head.

2-15. *Miter joints.* Miter joints are diagonal joints used extensively for frames and moldings. Shown in figure 5, A, is a plain miter joint, which can be fastened with glue, dowels, wood screws, nails, or corrugated fasteners.

2-16. The mitered half lap joint (see fig. 5, B) is similar to the end lap joint and can be mitered to any desired angle. This type of joint can be fastened with glue, nails, wood screws, or a combination of glue and metal fasteners. The splined miter is a method used to reinforce

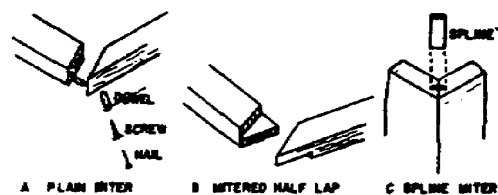

Figure 5. Miter joints.

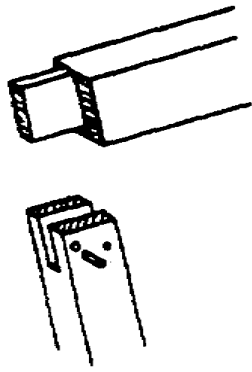

Figure 6. Open mortise and tenon joints.

a plain miter joint. Shown in figure 5, C, is one way of inserting a spline in a miter joint. A miter joint with a spline is usually fastened only with glue. Joints of this type, if made with hand tools, must have each piece marked. However, if power machinery is used, then only one layout is necessary to set up the machine.

2-17. *Mortise and tenon joints.* The mortise and tenon joint is one of the oldest and most used joints in cabinet construction. The numerous variations of this type of joint provide ample choices for framing doors, panels, tables, chairs, and cabinets. Of these variations, we will discuss four: open, through, blind, and haunched mortise and tenon joints.

a. *Open mortise and tenon joints.* These joints are sometimes called slip joints, as illustrated in figure 6. As you can see, the mortise is cut completely through the end of one piece, which is open on three sides, and the tenon is slipped into this open mortise. It is a strong joint and can be used on various types of frames. This type of mortise and tenon joint can be nailed, screwed, pegged, or glued for added strength. Another version of this type of joint is the bridle joint, illustrated in figure 7. However, in this version one member is joined in the center.

b. *Through mortise and tenon joints.* These

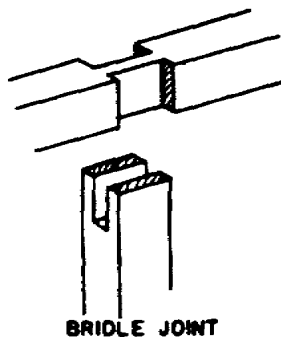

Figure 7. Bridle mortise and tenon joints.

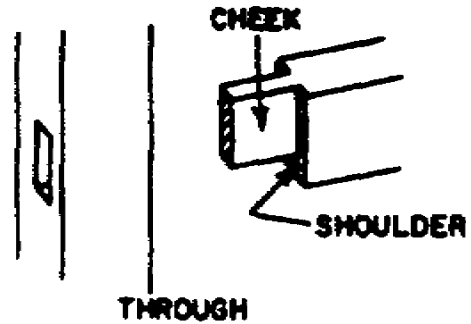

Figure 8. Through mortise and tenon joints.

joints are those in which the mortise extends completely through one member. (See fig. 8.) When wedges are driven into the end of the tenon, it is called a wedged mortise and tenon joint, as illustrated in figure 9. For rough knockdown or outside furniture, the tenon can be cut longer than the depth of the mortise, with a hole drilled into the protruding part of the tenon and a wedge driven close to the outer face of the member which has the mortise cut into it. (See fig. 10.) When this is done, it is called a keyed mortise and tenon joint.

c. *Blind mortise and tenon joints.* These joints are those in which the mortise and tenon do not go completely through the mortise member, as shown in figure 11. They are used for doors, table legs, rails, and panels when it is desired that no part of the mortise or tenon be seen after the work is assembled.

d. *Haunched mortise and tenon joints.* These joints are used when a groove is cut into the framing where the mortise and tenon will fit. Figure 12 illustrates how the tenon is cut to fit into the groove after the tenon is inserted into the mortise. These are used often for framework where grooves are cut for panels.

2-18. When making a mortise and tenon joint, make sure the tenon has at least one shoulder where the greatest stress is anticipated. For additional strength on wide stock, provide a double

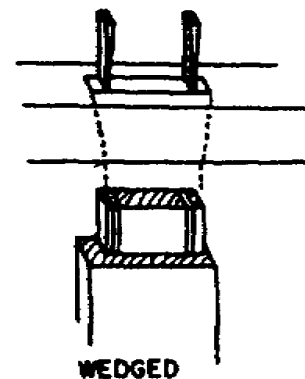

Figure 9. Wedged mortise and tenon joints.

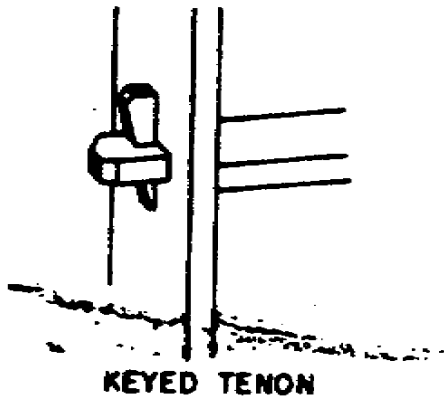

Figure 10. Keyed mortise and tenon joints.

mortise and tenon. This eliminates a springy tenon and gives more shoulders which can rest against the sides which have the greatest stress. Before starting any mortise and tenon joints, be sure the stock is squared. To determine the proper thickness of a tenon, compare it with the member of which it is a part. The thickness should be approximately one-third the thickness of the member. The tenon should fit snugly but not bulge the sides of the mortise or have to be driven into it.

2-19. *Dovetail joints.* One of the strongest and neatest of all joints used in cabinetwork is the dovetail joint. For a corner joint, the dovetail is considered a mark of good workmanship, and a good fit can only be achieved by accurate and painstaking labor:

a. Single dovetail joints, like the one shown in figure 13, are used for drawing boards, tabletops, drawers, etc.

b. Finger, or box, dovetail joints are those which have square fingers and tails, as shown in

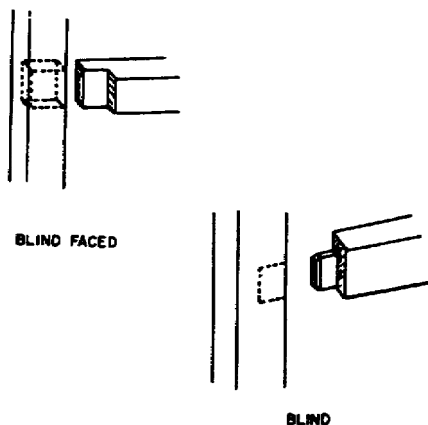

Figure 11. Blind mortise and tenon joints.

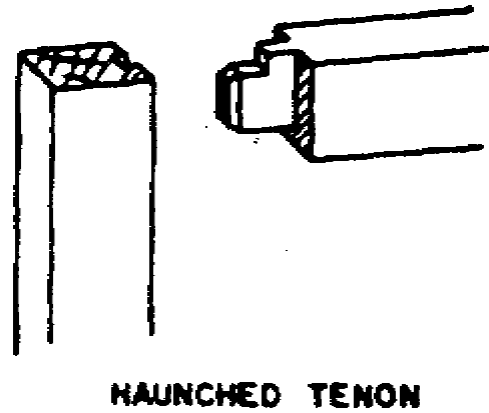

Figure 12. Haunched mortise and tenon joints.

figure 14. They are used primarily for corners of small boxes.

2-20. There are a few good rules to follow when making dovetail joints. In softwood, the tails should be wider than they are deep. For hardwood, the face (widest part) of the pins, or fingers, should be at least three-fourths of the thickness of the wood.

2-21. It is not feasible to try to explain each step in laying out the fingers and tails of each type of dovetail joint, but it does take experience and patience to make them.

2-22. *Dowel joints.* Similar to the one shown in figure 15, dowel joints are used extensively to reinforce boards that are glued edge to edge or otherwise butted together. The dowels are made of birch and the standard diameter sizes range from three-sixteenths to one inch. When you bore holes for the dowels, use a bit the same size as the dowel. The size of the dowel should be large enough to support the intended job but not so large as to weaken the work rather than strengthen it. The diameter should be approximately one-third to one-half the thickness of the stock on which it is being used, and all holes must be bored straight so that the dowel will not be forced into a bent position. It is good practice to

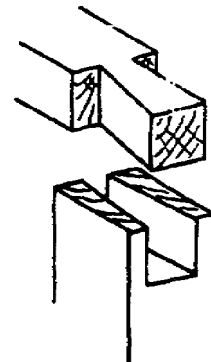

Figure 13. Single dovetail joints.

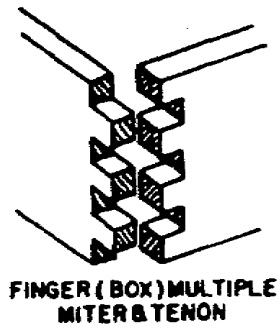

Figure 14. Finger or box dovetail joints.

cut the dowels one-eighth inch shorter than the combined depths of the holes and to point the end with coarse sandpaper or a knife. Dowel joints are always glued and are often used as a substitute for mortise and tenon joints. To allow air and excess glue to escape, cut a channel, or spiral, the full length of each dowel.

2-23. *Corner joints.* Corner joints, other than the mitered, butted, doweled, or dovetailed types, are used extensively in the construction of drawers for furniture and cabinets. A corner joint is shown figure 16. A. One member of the joint is rabbeted, with the other member fitted into the rabbet and fastened with glue, nails, screws, or a combination of glue and a metal fastener. The box corner joint, shown in figure 16. B. consists of two members, one dadoed and the other rabbeted to fit the dado. This corner joint is pri-

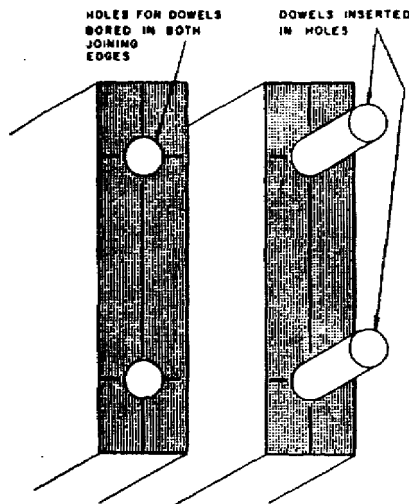

Figure 15. Doweled joints.

marily used for the rear corners of drawers. The milled corner joint, shown in figure 16, C, consists of two members with milled grooves that are fitted together. This joint is used for the front corners of drawers, because it will resist the pull exerted on the front of the drawer.

2-24. By now you should have a good idea of both the wood used and the types of joints required to construct an article. With this information firmly in mind, let's take a look at the recommended procedures for constructing a wooden article.

2-25. *Butt joints.* The butt joint consists of two members that are fastened together end to end without overlap. This joint is often strengthened with a strap or straps.

3. Constructing Wooden Articles

3-1. You can probably remember the furniture in your grandmother's home when you were a youngster. Today, your grandmother's furniture would be considered as old fashioned as that

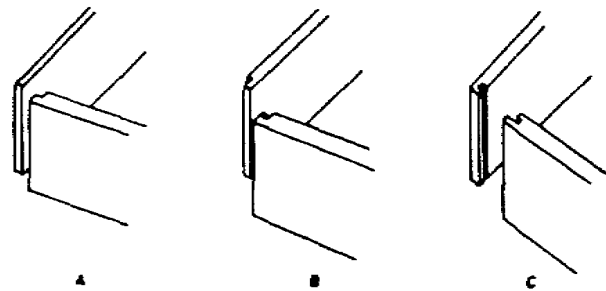

Figure 16. Corner joints.

of her grandparents, because designs and styles continue to change. Modern-day furniture designers try to create furniture that will give us convenience, comfort, and beauty.

3-2. Along with the many style changes, mass production methods and new materials have changed cabinet construction procedures. However, the basic forms of construction remain relatively the same as they were when our so-called antiques were made. Today, however, there are more "built-ins" in the form of cabinets, dressing tables, and workcounters.

3-3. This section will provide you with the knowledge you will require to construct and repair cabinets; it will also cover types of construction, which include frame, stool, and box. The procedure used in the selection of materials for the items covered in this section are also extremely important and should be followed as closely as possible.

3-4. The last two major topics in this section are the assembling of parts into complete units



Figure 17. Frame construction.

and final inspection of your finished work. Obviously, knowledge of construction fundamentals and of which materials should be selected-and how-is useless to you if you do not put your piece of work together adequately and carefully check your completed article.

3-5. You may have the opportunity to construct new cabinets, or your work may consist only of rebuilding damaged ones. Remember to apply what you have learned. By doing so, you will produce an article out of wood that will make you proud to say, "I made it."

3-6. **Constructing Cabinets.** Before you start constructing a cabinet, become familiar with all of the building details and prepare a bill of materials. As you study your drawing, you will find that the article to be constructed can be classified in one of three forms of cabinet construction. Regardless of the cabinets you make, use one of the three general forms (frame, stool, or box) or a combination of them. These three forms are the basis for all cabinet construction and can be adapted to fit any design; however, special methods must be used where intricate shape are desired.

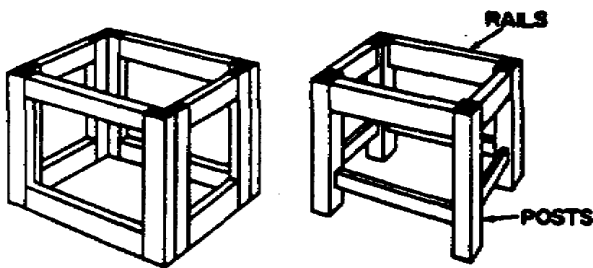

Figure 18. Stool construction.

3-7. **Frame construction.** Frame construction consists of a grooved frame and a panel which fits into the groove. The framework adds strength because the grain of the wood runs lengthwise in both length and width. Frame construction is highly desirable, because it overcomes shrinkage and swelling and provides ample strength for the panel. Figure 17 illustrates a simple type of frame construction which is used extensively in cabinet construction. The various joints we have covered can be used to fasten the frame together.

3-8. **Stool construction.** As shown in figure 18, stool construction may be regarded as four frames put together to form a rectangle or square. It is used for tables, chairs, stands, and many types of cabinets. Mortise and tenon joints and dowel joints work well in stool construction. When fitting this type of construction with a top (for example, a tabletop), do not secure the top with glue, because wood shrinks across its width and the top must be able to give with the shrinking

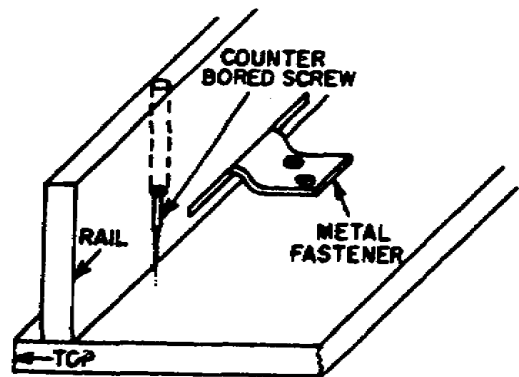

Figure 19. Securing tops.

and swelling process. Figure 19 illustrates how a tabletop is secured in stool construction. If the rails and top shrink or swell, then the top can move without splitting.

3-9. **Box construction.** Box construction is used for articles made from solid wood, such as chests of drawers, cupboards, and bookcases. Any item built without a framework comes under the heading "box construction." Figure 20 illustrates one type of box construction. When using the box construction method, use rabbet, butt, mitered, or dovetail joints.

3-10. **Selection of Materials.** Now that we have discussed the three forms of cabinet construction, let's assume that we have our drawing, have checked all the details, and have made out our bill of materials. After this assumption, select the materials needed. When selecting materials for your project, bear in mind how and where the article will be used. Normally, you would not use the most expensive trade of ma-

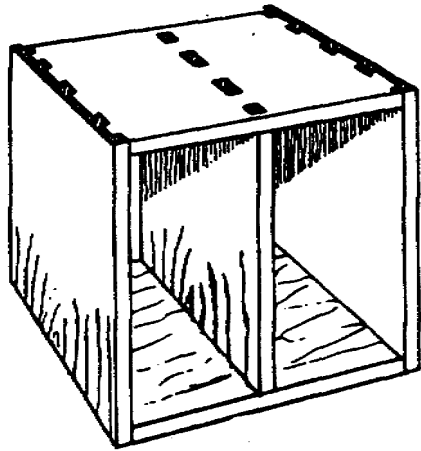

Figure 20. Box construction.

material for a cabinet which would be used for tools. How the article will be finished also has a bearing on the material you will use. If your article is to be painted, use material with minor defects that the paint will cover. If the article is to have a clear finish, then use a better grade of material.

3-11. After the material has been selected, you are ready to mill the stock and form it according to the blueprint or drawing.

3-12. Posts or legs used in stool type construction to support articles such as tables, chairs, and stools are often milled to decorative shapes, using the wood lathe. Refer to your blueprint for the size of the posts, and mill them to these specified sizes and shapes.

3-13. Fasten posts to the rails (see fig. 18) with mortise and tenon or dowel joints. If mortise and tenon joints are used, mortise each a side rail, while the other side receives one tenon of an end rail. If doweled joints are used, drill dowel holes on the sides in place of the mortises. When you make mortises or dowel holes, pair off your posts; in other words, label them left and right. As you do this, keep the best sides for the face sides. The face sides are those which will be seen when the article is assembled.

3-14. Rails, when assembled with posts, form a square or rectangular-shaped frame supported by the posts. Your blueprint will give you the dimensions for the length and width of the rails. The material you selected must be milled to these dimensions, using the jointer, planner, and table and cutoff saws. When you cut the rails to length, add the length of each tenon if mortise and tenon joints are used. Rails that are fitted with a panel, as shown in figure 21, must have a groove cut on the pane edge of each rail.

3-15. Tops are used in all three forms of construction previously mentioned. Most often, they are large enough to require two or more pieces of stock to be glued together. The pieces can be joined with glue, using various types of joints, such as the tongue and groove, butt, and dowel. When selecting the material to be glued together, make the selection so that each piece has similar grain characteristics, and glue them so that the grain of each piece has some semblance of matching. We repeat, the method used to fasten the top to a cabinet or piece of furniture is an important consideration, because of the swelling and shrinking of the top.

3-16. In your job, you will probably install laminated plastics on some surfaces, especially cabinet tops. These plastics are manufactured in sheets, or rolls, ready for use; therefore, the only thing you have to do is to install them. Laminated plastics also come in different lengths, widths, and thicknesses. When you install this material, select the nearest size sheet, or roll, to the size you need for your particular job. After you select the correct size materials, be sure that both surfaces to be bonded are smooth, clean, and dry. Before you open the contact cement container, read the instructions on the container and follow them religiously, because the contents in the container are extremely flammable and harmful or fatal if swallowed. Shake the contact cement in the container vigorously before you use it. Open the container and, using a short-fibered

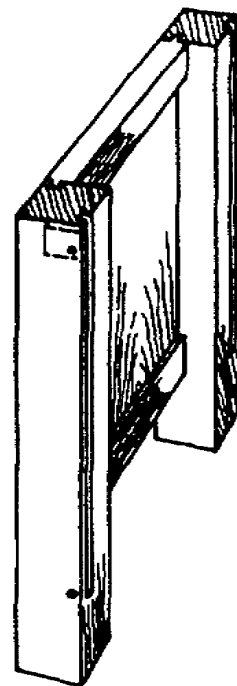

Figure 21. Rails fitted with panel.

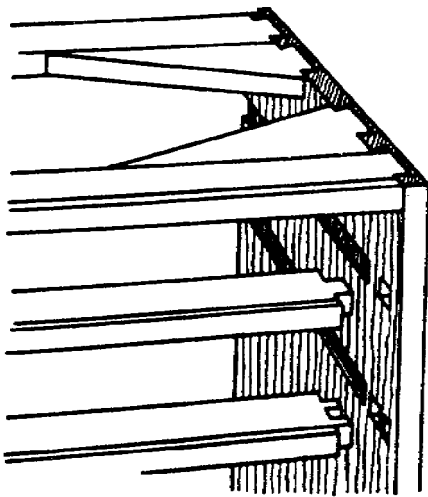
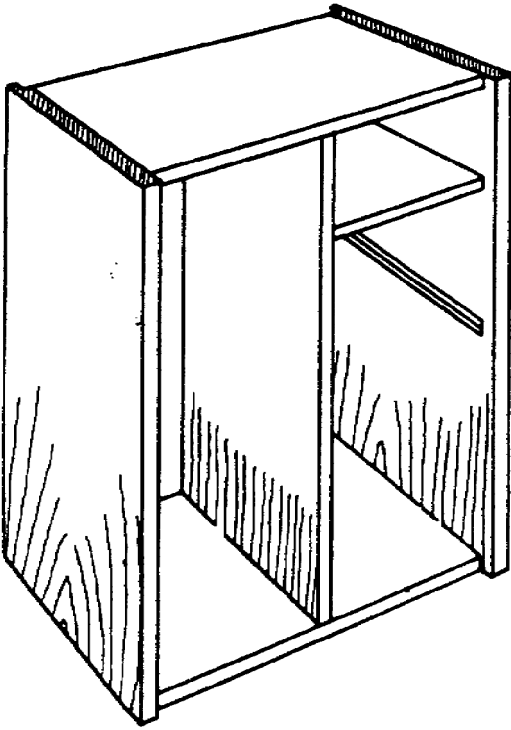

Figure 22. Dado and mortises for box construction.

paint roller or a wide brush, spread the contact cement on the back of the laminated plastic top and on the surface to which you are going to apply the plastic. One full coat is usually enough on nonporous surfaces (back of laminated

materials or metal). Porous surfaces, such as wood, usually require two coats. When you use more than one coat of contact cement, allow it to dry thoroughly between coats. Be sure that you allow the contact cement to dry before you bond the laminated plastic top. Position the surfaces carefully, because no adjustment is possible after the contact cement films make contact. Use scrap plastic, thin wood, metal strips, screen wire, or some other material to separate the contact cement films when you are positioning large pieces of laminated plastics. Apply pressure immediately and firmly with a 3-inch-wide roller or a rubber-faced hammer, working from the center to the edges over the entire surface. Only momentary pressure is needed, but the more pressure you apply within the limits of the bonded material, the stronger the bond will be. Trim and finish the job with a router as soon as you have completed the bonding process. You can knock the sharp edges off with a file if needed.

3-17. Sides, ends, or backs can be constructed with frame, stool, or box type construction or a combination of all three. For a combination of frame and stool construction, the sides would be paneled, as illustrated in figure 21. This requires an upper and lower rail with a groove cut into the rails and the posts. This type of construction is used primarily for desks. The plywood used for the panels should have the best side out for appearance sake. The same applies to the rails and posts. Be sure to cut the panels square and to remove the rough edges from around the panel. Smooth edges will help the panel slide into the groove easily. The groove must be large enough for the panel to slide into without its being driven.

3-18. In box type construction, the sides and ends are usually solid, similar to a top. Articles such as dressers and chests of drawers usually have the pieces which make up the ends and sides glued to make them wide enough. Check your drawing for the correct dimensions and allow a little extra so that you can mill the sides and ends to these dimensions after the pieces have been glued together. In this type of construction, the solid sides or ends are rabbeted on the back edge to receive the back, which is usually a piece of plywood. The rabbet is cut after the stock has been milled to the specified size. The interior side may also need dados or mortises cut to receive drawer rails or shelves, as shown in figure 22. These are cut to the correct size and depth after the milling process.

3-19. Frame type construction for sides, ends, or backs (see fig. 23) is made by assembling the various panels together according to your drawing. When you form the various parts, keep the best sides out for the rails and panels. Cut the

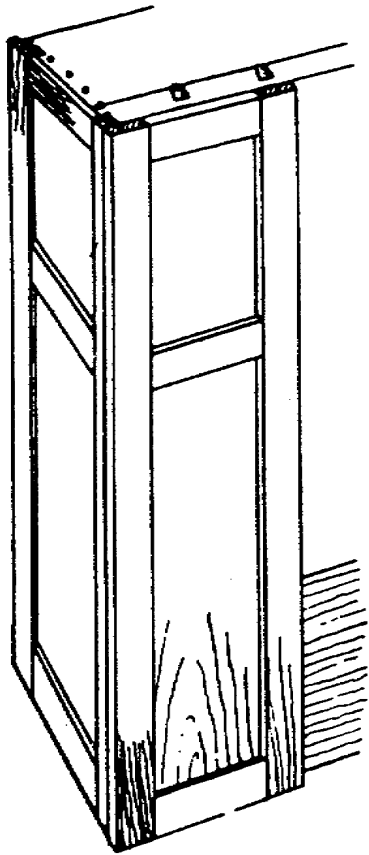

Figure 23. Panels for frame construction.

panels square, remove the rough edges, and be sure that the groove is large enough to receive the panel.

3-20. Doors used on cabinets and furniture can be classified as paneled or flush. Flush doors are usually made solid or with a frame covered with plywood. The frame for panel doors can be mortised and tenoned, doweled, lapped, or mitered. Your drawing will give you these details. The material for the framework is milled to the dimensions specified on your drawing. After the milling process, the rails and stiles are cut to length. The material for the framework is milled to the dimensions specified on your drawing. After the milling process, the rails and stiles are cut to length. The joint to be used is made along with a groove in each rail and stile for the panel. Sometimes a molding is cut on the inside edge of the frame near the panel. (See fig. 24.) Before cutting the molding, select the best side of the frame to show when the doors are closed. If any joint other than a miter joint is used, the molding must be mitered, as shown in figure 24. The hinged side of the door should be planed true with the top and bottom, and the lock side should have a slight angle to provide clearance

for opening. When you fit doors, remove the waste equally from all stiles and rails so that their width will stay balanced.

3-21. Flush doors for most cabinets are solid and are cut to the specified dimensions shown on your drawing-making sure the tops, bottoms, and hinged sides are true.

3-22. Regardless of the type of door, the material selected must be straight and have good grain characteristics. If the material for the doors must be glued, match the grain characteristics. When you mill out material for more than one door-especially for double doors-do it all at one time.

3-23. If the article you make has drawers., there will usually be a detailed drawing of the drawer construction along with your blueprint. Check your plan for the thickness and width of the sides, front, and back of each drawer, and then mill the stock to these dimensions. When you start cutting the joints for a drawer, mark the pieces "sides," "fronts," and "backs," with the side pieces marked "lefts" and "rights." The reason for this is that bottoms of most drawers are inserted into grooves cut on the inside of each side, front, and back piece of drawer. This is clearly illustrated in figure 25. Plywood used for the bottom of the drawers should have the good side up so that it can be seen when the drawer is opened. It is essential to have all material cut square if the drawer is to fit well. Wood used for side and back pieces can have slight defects; however, they must be placed so that they cannot be seen from the inside when the drawer is open. Material for the drawer fronts

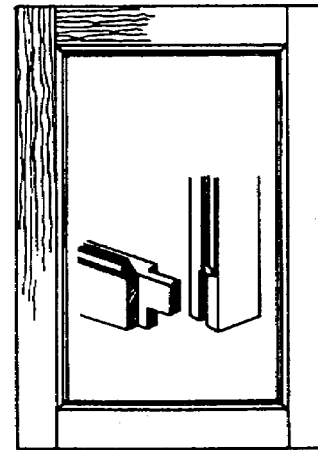

Figure 24. Molding on paneled door.

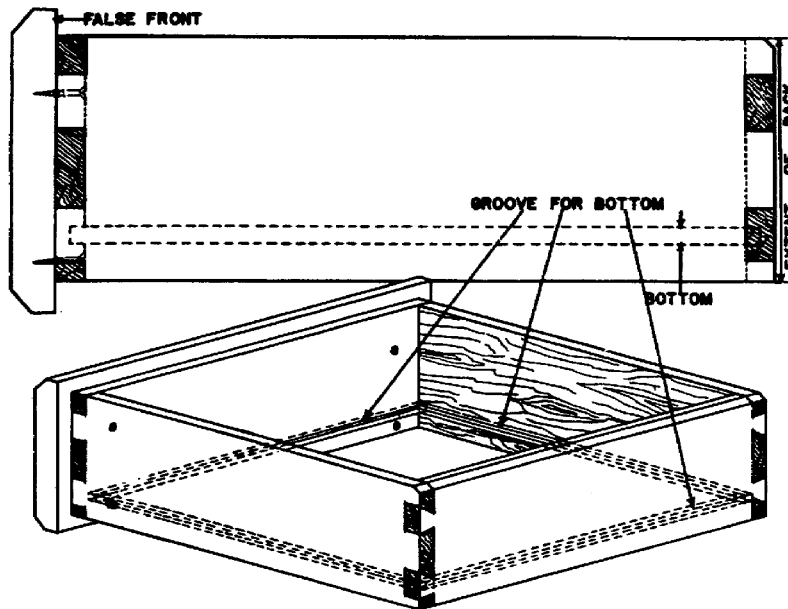

Figure 25. Detail for drawer construction.

should have a pleasing grain, and if more than one drawer is used, the grain characteristics should be similar on each front. This is true for a clear finish but is not important if your articles will be painted. Your drawing may call for a false front on a drawer (see fig. 25); if so, the material should be carefully selected and milled to the dimensions specified.

3-24. We have discussed the various parts you will have to mill in any one of your projects. Before you begin to assemble any of these pans into units, sand each part to remove toolmarks or other blemishes. The greater portion of the sanding should be completed before the parts are assembled, so that after an article is assembled, it needs only touchup sanding to have it ready for finishing.

3-25. Always sand with the grain—never across it—or you will mar the surface of the wood with scratches. Figure 26, A, illustrates the correct direction the sand block should move when you are sanding by hand. The other three parts of figure 26 show incorrect use of the sand

motion when sanding flat surfaces; instead, use long, even strokes.

3-26. If parts of the article you are making have irregular curves, sand them on the spindle part of the disk and spindle sander; however, if a sander is not available and the curves are long, sand by hand with a block. The block guards against rounding the edges. Sand inside curves by hand, using a stick with a rounded surface. (See fig. 27.)

3-27. For all lathe turnings, such as the posts for tables, stools, or the rungs of chairs, make sure each turning is sanded to a smooth surface before you begin any assembly work.

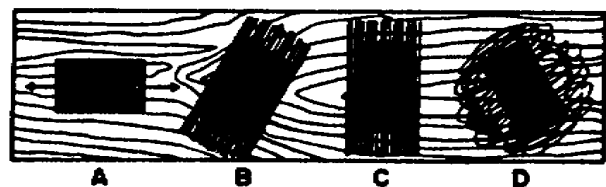

Figure 26. Direction for sand block.

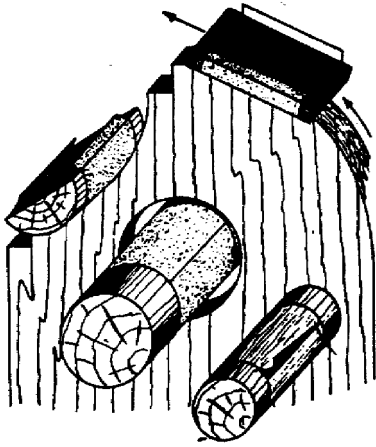

Figure 27. Sanding curves.

3-28. Assuming that all individual parts have been sanded, you are ready to begin the first step in assembling your article into a unit.

3-29. **Assembling the Parts into Unit.** Assembly of the parts into a unit is done after all pieces have been milled to size, shaped, and sanded. Before you assemble the unit into its final form, make a preassembly check. Make sure that all pieces are ready to be assembled by checking each piece for dimensions, shape, and fit.

3-30. Dimensions are checked first to see that they correspond with those on the drawing. Each dimension must be exactly as long, wide, and thick as the drawing specifies.

3-31. Check shapes with a try-square or T-bevel, making sure that all angles are correct. A

board may be of the specified dimensions, but if the angles are not properly measured according to the drawing, proper shape cannot be achieved.

3-32. Check your work by actually fitting one piece with its counterpart. After all, a board can be of correct dimensions and shape and still not fit properly. Obviously, then, all three-dimensions, shape, and fit-must be checked in a preassembly. Forming this habit will enable you to eliminate disappointment and save trouble, time, effort, and material.

3-33. **Final Inspection.** After the article has been assembled and all glue joints have been given time to dry, make a final check before applying the finish. This check will include: (1) all angles for proper cut and fit, (2) all joints for excessive glue, and (3) the entire surface for blemishes.

3-34. So far we have covered some of the woods used in cabinetwork, along with the types of joints used. We have also covered the procedure used to construct a wooden article. However, as a carpentry specialist, you will be required to repair or replace parts or sections of cabinets. If you remember how to select materials for constructing an article, you should not have any trouble selecting materials for the repairing or replacing of sections. Some of the items to check for are the kind of wood and grain characteristics; that is, the piece being replaced should have the same grain texture as the original and the color should be the same. You may also construct models, mockups, and patterns. These items will require a great deal of time and skill to construct. For this reason, detail drawings will be furnished to aid you in the construction. These items are usually fastened together with screws, dowel pins, and glue. The method of fastening these items together will be shown on the particular drawing you will be using.

CHAPTER 2

Prefabricated Buildings

TODAY, ARMY installations all over the world are using prefabricated buildings. These buildings are used mostly in localities where materials cannot be purchased locally. To save time and material, as well as to simplify erection, prefabricated buildings are standardized and available for use in Temperate, Tropic and Arctic regions.

2. As a carpentry specialist, you will be erecting prefabricated buildings. Like other structures, they must start with a good foundation. As we follow the procedures for the erection of one of these buildings, you will see that its construction is similar to that of any frame building.

3. Besides constructing buildings, prefabricated or otherwise, much of your time will be spent in keeping the buildings good repair. This is your work in maintenance and repair. Maintenance and repair work will challenge all of your building skill. You will inspect work done by others, some of it done a long time ago. Whether it was poorly done or is just wearing out so that it could require expensive repairs, you will be able to correct the trouble.

4. This chapter discusses erecting, maintaining, and repairing prefabricated buildings. It also discusses the requirements for constructing these buildings in Temperate, Tropic and Arctic regions.

4. Prefabricated Wooden Buildings

4-1. A prefabricated (prefab) wooden building is assembled of precut members. The joists, plates, studs, rafters, etc., are ready for assembly when they are delivered to the building site. In some cases the precut pieces may be partially assembled into standard size panels. These pane may be designed for use with a frame or they may be shaped in such a manner that the can be bolted together to form floors, walls, and roofs. Let's look at the construction of each type and the method of making repairs.

4-2. **Paneled Prefabricated Buildings.** A wood prefab that is assembled of panels will have an

outward appearance similar to the building shown in figure 28. The vertical strips used to cover the joints between the exterior wall panels distinguish this building as a panel type prefab. Look at figure 29 and then compare it with figure 28. Figure 29 shows a partially assembled panel type prefab building, while figure 28 shows a completed building. Note the distinct lines made by the joints between the panels. Also, note in figure 29 that the framework is a part of the panel and that no separate framing is required.

4-3. *Floors.* The floor of a panel prefab building consists of flooring, joists, and girders. The boards are fastened to two or three joists to form a panel 4 feet wide and 8 feet long. The panels are placed on girders that are supported by posts or column. The panels are fastened in place with screws, and the joints between the panels are covered with a T-shaped metal strip. When plywood is used for the floor, the edges are protected by an H-shaped metal strip that is inserted between two panels. This strip also prevents dust and small objects from collecting in the joint. The panels are easily removed without damaging the edge or the metal strip. If you remove the end or side panels first.

4-4. Repairs can be made to individual floor panels in the same manner repairs are made to floors in other buildings. Also, the panels are interchangeable. Repaired or weak panels may be moved from the main path of traffic and exchanged with stronger panels located in other parts of the building.

4-5. There is a variety of floor panels for this type of building, but only one type should be used on your post. Some panels have a subfloor, insulation, or both. The type you use will depend on the particular use to which panels will be put and the climate in which they will be used. For example, flooring which must have heavy equipment must obviously be much stronger than that which will bear light equipment. Again, panels intended for use in hot, humid climates, such as are common in the Trop-

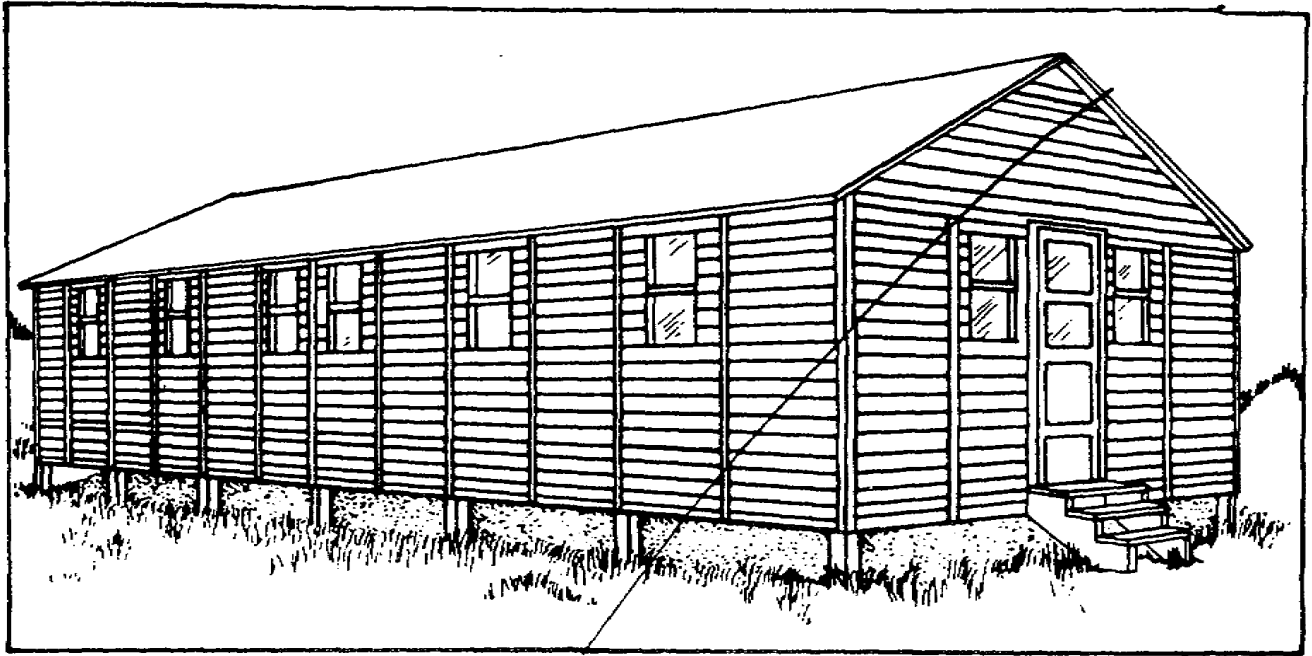

Figure 28. Prefabricated wooden building.

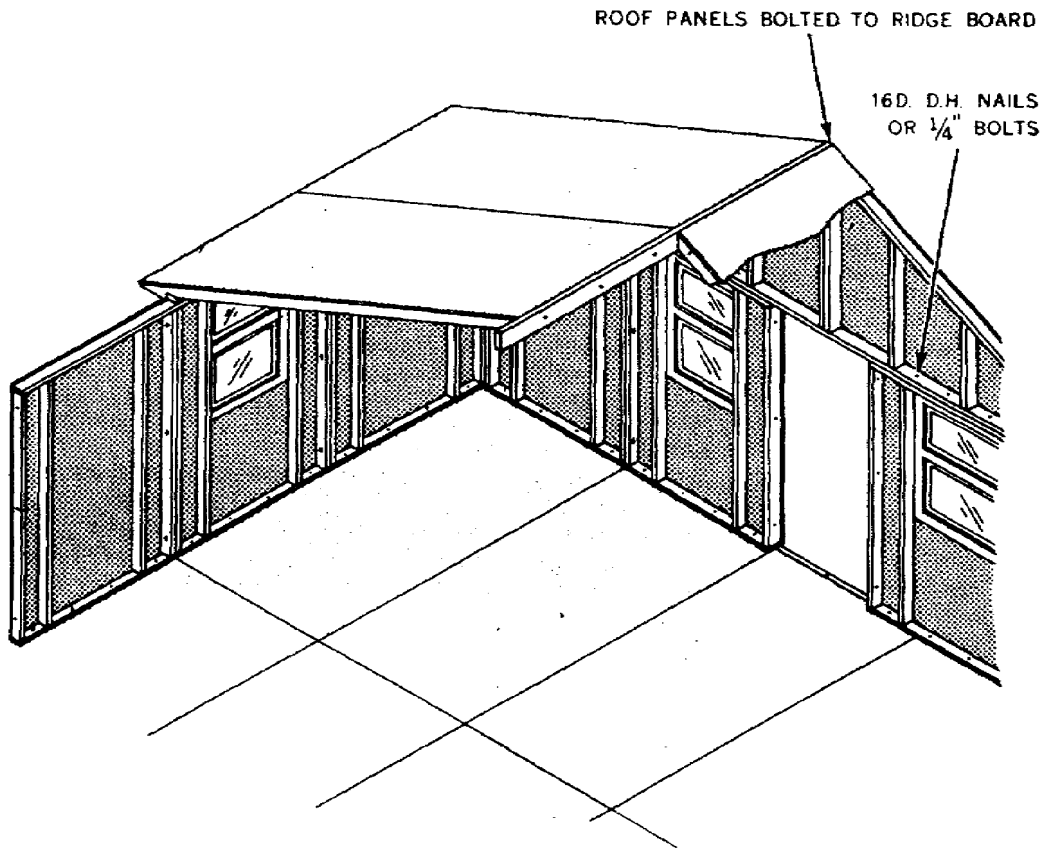

Figure 29. Prefabricated wooden panel building.

ics, are not, for this reason alone, suitable for use in the cold, low humidity, and dryness of the Arctic regions.

4-6. *Walls.* The panels used for the exterior walls consist of an exterior covering on a light frame. The covering may be fiberboard, plywood, or siding. The frame may be made of 1x1, 1x2, 1 1/2x1 1/2-, or 2x2-, or 2x3-inch material. Where insulation is required, a fibrous filler is installed between the exterior and interior coverings.

4-7. Doors and windows are assembled within a standard size 4x6-or 4x8-foot panel. The panels are interchangeable so that you can relocate windows, door, and solid sections as desired.

4-8. The wall panels are fastened in place with double-head scaffold nails or lag screws (bolts). Bolts are used to fasten two panels together along the vertical edge, as shown in figure 29. The fasteners used in this prefab can be easily removed without damaging the panels.

4-9. Repairs to wall panels usually consist of replacing 1x2 or 1x4 strips over the vertical joints and replacing wall coverings. The parts of insulated panels are assembled with glue and cannot be disassembled. You can repair a damaged area on a fiberboard covered panel by installing a fiberboard patch. Make the patch large enough so that you can fasten at least two edges of it to the framing members. Use a waterproof glue to fasten the other two edges. Glue may also be used to fasten small plywood or fiberboard patches if they cannot be fastened to the frame.

4-10. Sticking doors and windows are a problem in this type of building when the panels weaken or begin to warp. If normal adjustments do not correct the situation, you may have to strengthen the panel. Replacing the panel covering with new material will give it additional strength. Adding an interior covering on the panel will also help to reduce its flexibility and keep it straight.

4-11. The panel type prefab building does not have corner braces. As the building becomes older, it is weakened, and wind pressures may cause the building to lean or shift slightly and the windows and doors to bind. You can use guy wires at each corner to help prevent excessive shifting of the panels. The guy wire should be attached at the top of the corner panel or near the eave of the corner roof panel. The other end of the wire may be fastened to a stake, another prefab building, or a solid structure. These guy wires are a part of the original assembly when the prefab building is used in an area of strong prevailing winds.

4-12. *Roof.* Roof panels are built according to the climatic conditions that exist where the

building is to be used. A panel that consists of a 2x2-inch frame and fiberboard covering is sufficient for some areas. Heavier 2x4 frames are used with one inch decking or plywood where snow loads are expected. Insulated panels are used in both hot and cold climates.

4-13. Roof panels are fastened at the top of the exterior wall panels and at the ridge. A ridge board is placed between the upper end of two roof panels, and bolts are used to hold them together, as shown in figure 29. The side members (rafters) of the panel frame are bolted to adjoining panels.

4-14. Some roof panels have offset edges so that they fit together with a lap joint (see fig. 1 and pars. 2-9 and 2-10 in ch. 1) like shiplap lumber. This joint helps in lining up the panels and also helps in preventing leaks. The joints between the panels are sealed by covering them with a bitumen adhesive and cloth strip. Since expansion, contraction, or any other movement of the panels will damage the joint seal, you will probably have to renew or replace the seal every year or two. When extended usage is planned for the building, it is best to cover the entire roof with a layer of roll roofing. The roofing can be cut at the panel joints when the building is disassembled.

4-15. The roof on this panel prefab building is not as strong as standard wood construction. Therefore, you must be careful when you check or repair the roof panels. Make a temporary walkway by using a 1x12-inch board (with cleats) that will extend from the eave to the ridge. When you replace joint seals, start work at one end of the building and work toward the other to avoid walking on or near the repaired area. Don't walk back across the panels after completing your work. Unnecessary walking on the roof will break the joint seals, and you will have to replace them again.

4-16. **Framed Prefabricated Buildings.** The framed prefabricated wooden building is also known as a precut or light frame building. The framing is precut and prepared for assembly before it is delivered to the job site. The studs and rafters are widely spaced, as shown in figure 30. Let's take a look at the construction of this building.

4-17. *Floors.* The floor of the framed prefab building consists of flooring, joists, and girders. A combination subfloor and finish floor is used where a smooth finish or the additional insulating value is required. Girders extend around the perimeter and along the centerline of the building to support the joists. The joists are spaced 24 inches on-center with each length of joist spanning the distance between the girders. The

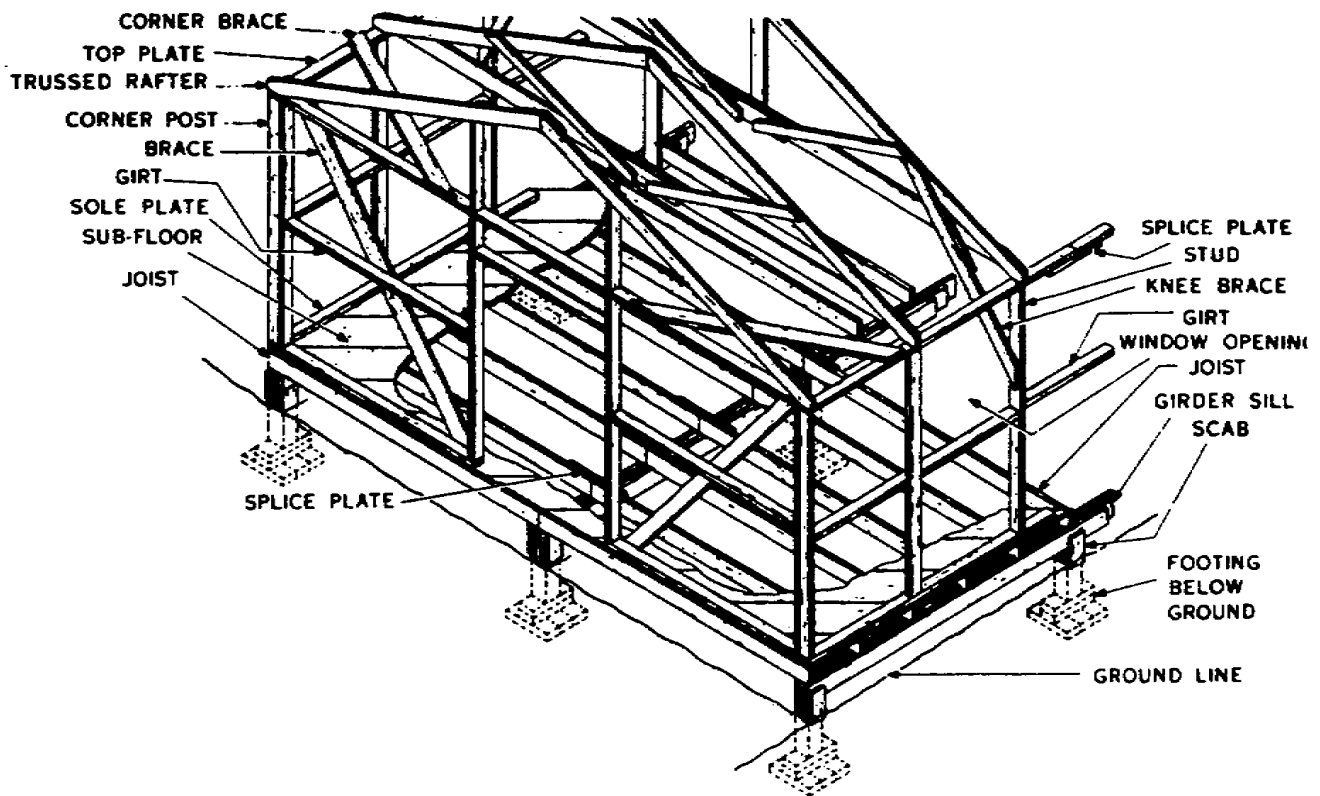

Figure 30. Prefabricated wooden frame building.

subfloor is laid either diagonally or perpendicular to the joists. The finish floor, if one is used, is laid lengthwise in the building. This type of building may also be used with a concrete slab floor.

4-18. Repairs to the floor consist of replacing individual pieces of flooring. Recovering with a layer of plywood may also be justified if the walls and roof are in good condition and the building can be used for several more years. Use a layer of 15-pound felt between the layers of flooring to prevent dust from entering through the joints. Tile and linoleum are not used on wood floors if the floor is not reasonably solid and covered with a smooth underlayment.

4-19. *Walls.* The walls in the framed prefab consist of studs, plates, girts, and braces. The sidewalls have studs spaced 4 feet on-center and the end walls have studs at the corner and beside the door opening. Single top and bottom plates are used on the ends of the studs. The bottom, or sole plate, is placed on top of the subfloor and is fastened to the subfloor and joists as in platform construction. The girt is a horizontal member located at about the center height of the wall. It serves as a fastening surface for exterior wall coverings. Notice the horizontal girts in the end section in figure 30. These girts serve as a fastening surface for 4x8-foot sheets of plywood that are placed horizontally.

The plywood may be placed either horizontally or vertically on the sidewall. Sheets placed horizontally help to brace the corners. Knee braces (see fig. 30) in end sections extend from the top plate at a corner to the bottom plate at the door opening. Set-in bracing (short lengths of 2x4's nailed between the studs at an angle) may be used in the sidewalls. Corner braces (see fig. 30) extend across a corner, from top plate to top plate, to hold the corner square.

4-20. The exterior wall covering may be 1-inch sheathing, fiberboard and insulation panels, or plywood. Rigid insulation boards may be installed as a first covering, followed by a felt membrane, a layer of plywood, and a layer of roofing felt. The roofing felt protects the exterior wall from moisture and eliminates the need for painting. Thin wooden strips or wood lathe are used to hold the roofing felt in place.

4-21. Your work on the exterior walls consists of adding additional bracing, repairing windows and doors, and replacing sheathing and felt. Torn felt should be replaced and fastened with wood strips. Check the wood strips that hold the felt covering in place. Draw loose nails up tight to hold the strips firmly against the felt.

4-22. *Roof.* The roof consists of precut rafters, ceiling joists, and braces that can be assembled on the job to make a truss. The ceiling joist extends the full width of the building and

is fastened to the lower ends of the rafters. The lower end of the rafter is seated on the top plate of the sidewalls, as shown in figure 30. The joint made by the joist and rafter is very important. The joist helps to prevent the lower end of the rafter and the top of the wall from moving outward. Perhaps you have noticed buildings where the sidewalls bowed outward and the ridge sagged in the middle. This is possible when the rafter and top plate pull loose from the ceiling joist. The load on the rafter forces the upper part of the wall outward, and the ridge line becomes lower. This also happens in permanent structures but is most common in light frames, where fewer and lighter ceiling joist are used.

4-23. The rafter spacing is the same as stud spacing, 4-foot on-center. A knee brace fastened to the rafter, ceiling joist, and wall stud is used every 12 or 16 feet for the length of the building. One-inch sheathing boards are used for the roof deck. Roll roofing is used as the roof covering. There is no roof overhang at the eave or gable, and the roof covering is lapped down the side walls to prevent leaks along the edge of the roof.

4-24. The interior of the light frame prefab is usually open, and leaks are easily located by a visual inspection. When a ceiling and partitions are used in the building, you must locate leaks by entering the attic or going on the roof. Don't walk around on the roof any more than is absolutely necessary. Instead, you should locate the leak by entering the attic and checking for water marks. Then go on the roof and make the repair. Use a 1 x 12 for a walkway and avoid walking between the rafters. The wide spacing of the rafters allows the decking to sag when you walk on it. Of course, old, brittle roofing may be broken beyond repair, and the only feasible way to fix leaks may be to put on new rolled roofing.

4-25. Most repair work on the framed prefab building is similar to the repair work on a standard frame structure. Just keep in mind that this is a light frame building. Repairs to the frame usually consist of nailing splices beside the faulty member rather than attempting to replace the frame.

4-26. Now that we have discussed wooden prefab buildings, let's see how prefabricated metal buildings are assembled and repaired.

5. Prefabricated Metal Buildings

5-1. The prefabricated metal buildings in use on some military installations are constructed of many different types of metal. However, galvanized sheet metal and aluminum are the most common metals used in prefab buildings. Most metal prefabs are referred to as portable buildings, because they are easy to disassemble and

relocate. When they are no longer needed in one area, they can be shipped to an area where they can serve a useful function. We will concentrate our attention upon two metal buildings that are frequently used: the advanced base hut and the light steel frame buildings.

5-2. **Advanced Base Hut.** The advanced base hut is usually referred to as a "quonset hut". The standard size is 20 by 48 feet. However, you will find that some of them are two or three times as long as this. They are planned so that they can be assembled in sections 8-foot lengths to make a building 8, 16, 28, etc., feet long. They are easily adapted for quarters, office space, workshops, training areas, supply storage, or any other function that can be placed within them. Nails, screws, and bolts used in the assembly of the quonset hut are easily removed when repair or disassembly of the unit is required. The primary parts of this hut are the floor and wall, so let's see how they are put together.

5-3. **Floors.** The floor of the hut consists of a metal frame with a plywood covering. The main support of the building is provided by five girders that run the length of the building. These I-shaped girders are spaced approximately 5 feet 1 inch on-center to provide support for the floor joists. The girder, as we called it in the wooden building, is referred to as an I-beam (its shape) or *joist sill* (its function) in metal construction. Joists spaced 2 feet on-center are placed on, and perpendicular to, the joist sills, as shown in figure 31. A U-shaped channel plate fastened to

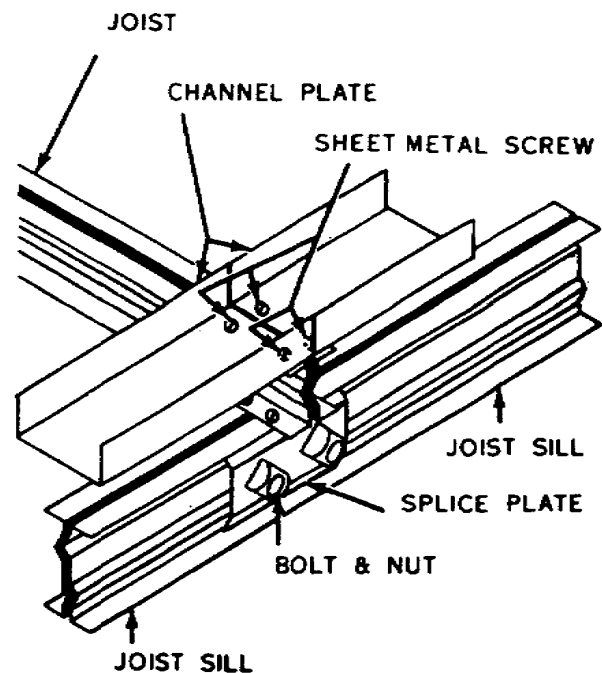

Figure 31. Sill and joist assembly.

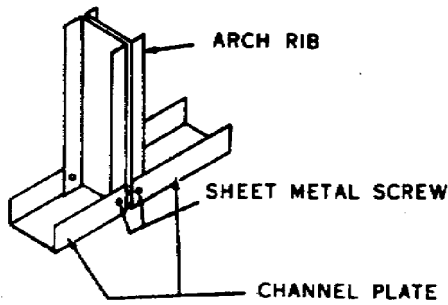

Figure 32. Joint and spline.

the top of the joists borders the floor and serves as a fastening surface for the end wall studs and arch ribs. Figure 32 shows the arch ribs connected to the channel plate. This channel plate is comparable to the bottom plate used in a wood frame building.

5-4. The floor is made of 4x8-foot sheets of plywood. Twelve sheets of plywood are placed side by side on the joist along each sidewall to cover the length of a 48-foot building. The two rows of sheets are butted against the channel plates of the side walls. Six sheets of plywood placed end to end fill the remaining 4 feet in the center of the building. The actual floor width between the channel plates is 20 feet 1 inch, or 1 inch more than the 2 lengths and 1 width of the plywood sheets used as the floor covering. This 1-inch space is divided between the two center joints to allow a 1/2-inch crack between the ends of the side sheets and the edge of the center sheets. These joints are protected by the H-shaped metal floor splines, as shown in figure 33. This spline protects the edge of the plywood, keeps the joint clean, and allows for movement of the plywood sheets. The wide joint and the slip-on spline make it easy for you to remove the center sheets, which are subjected to the most wear. Only 3 or 4 nails are used to fasten a sheet into place. Sixpenny common nails are driven through the plywood and into the groove in the joist. Notice the groove or separation along the top and bottom of the joist shown in figure 31.

5-5. *Walls.* The end walls of the hut consist of metal studs, channel plate, window and door headers, and corrugated sheet metal siding. The studs set in the channel are fastened into place with roundhead sheet metal screws. One screw is placed through the inside edge of the channel, and another is placed through the outside edge of the channel. There are 4 screw holes in the end of the stud, but it is not necessary to fasten through each of them except to splice two lengths

of channel plate. Alternate holes, inside right and outside left or inside left and outside right, are normally used. To remove a stud, you must gain access to both the inside and outside screws. Figure 34 shows the location of the framing members in an end section. The window and door headers consist of channels that are fastened between the studs. They serve as a fastening point for siding, interior finish, and the window or door frame.

5-6. The sidewalls and roof are framed with arch ribs, purlins, and window headers. The arch ribs are spaced 4 feet on-center and extend from the channel to the ridge or highest point in the building. Two arch ribs are spliced at the peak with splice plates and bolts to form a complete arch. The bottom of each arch rib is fastened in the channel plate with sheet metal screws. Headers for the side windows are fastened between arch ribs. Four purlins are fastened near the top of the arch, as shown in figure 34.

5-7. Corrugated sheet metal is used to cover the arch. It is fastened horizontally on the side of the arch to cover the area from the lowest purlin to the joist sill. The curved sheets that cover the top of the arch are placed across the purlins. Vents and roof jacks are built into the rounded sheets that are used on the purlins. These sheets are the same width and length as the others and are interchangeable with them so you can relocate the vents if necessary.

5-8. Repairs to the exterior walls usually consist of replacing the seals or retightening the fasteners around the doors and windows. Figure 35 shows the shape of a rubber seal that is used to prevent leaks at a joint made by corrugated metal and a flat surface.

5-9. When insulation is used in the walls of the quonset hut, it is fastened to wooden strips that are placed between the arch ribs. The interior covering consists of plywood panels, 1/2-inch thick, that are easily bent to fit the inside surface of the arch rib. An H-shaped spline is used along the sides of the plywood, and a wood strip is used to cover horizontal joints. Figure

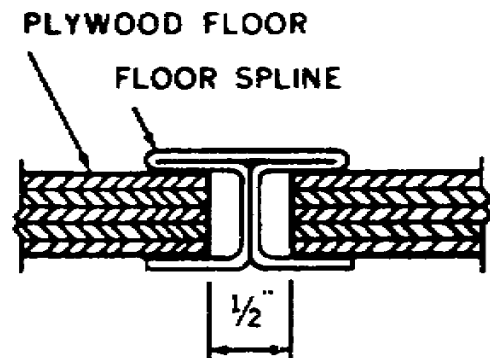

Figure 33. Splicing channel plates.

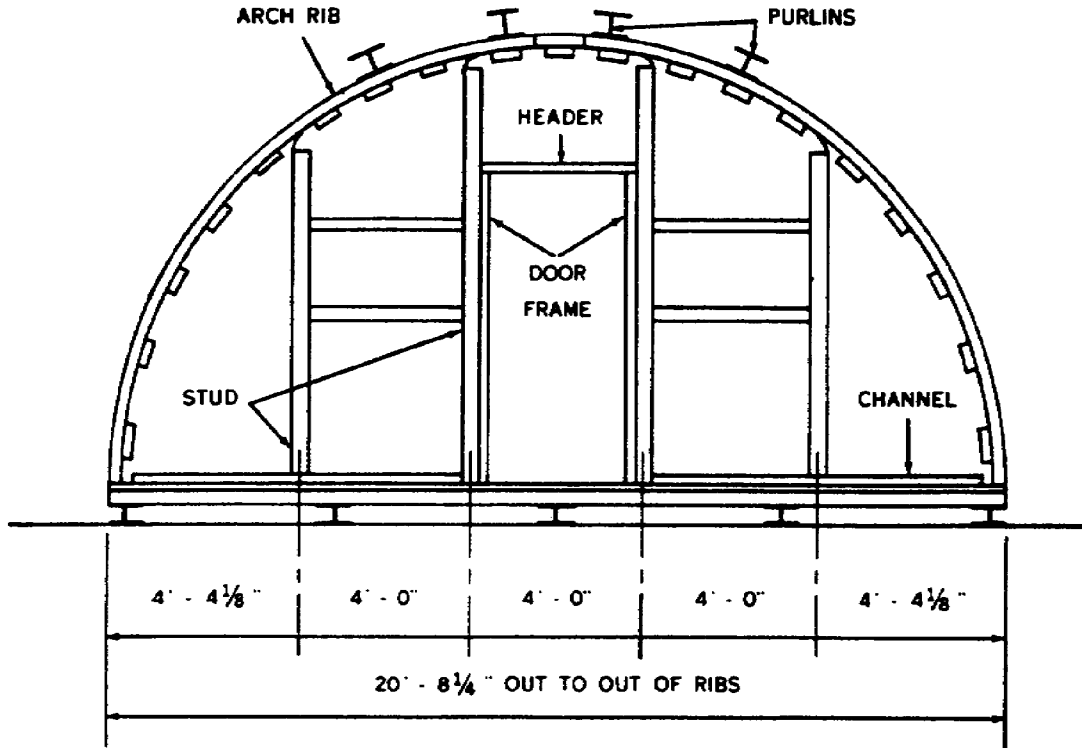

Figure 34. End wall framing.

36 shows the complete assembly as it appears at the bottom of the wall. Be very careful when you remove an inside panel. If you should loosen the adjoining panels, they may spring from the ribs and you will have more than a handful of panels at one time. Always have another worker with you when you remove the panels or corrugated sheet metal, because it is a two-man job.

5-10. **Light-Steel Frame Buildings.** The light steel frame building is a common building or many bases. It is usually a special-purpose build-

ing that has been put up to support one special function. The light-steel frame building is made in different sizes, with different types of light-steel frames. The frame shown in figure 37 is similar to the frames used for buildings of 20-to 50-foot width, with bays 12, 16, or 20 feet long, and exterior walls that are 10, 12, or 14 feet high. A bay is the distance between columns along the side walls. A bay is the basic assembly, and a building consists of one or more bays. There is no limit to the number of bays that can be placed end-to-end to form a building. The frame shown in figure 37 is often referred to as open-bay construction, because there are no supports needed in the bay. The area between the side walls is open, unobstructed space.

5-11. *Framing.* The end wall frame is assembled of prefabricated parts. Each piece of metal is shaped and drilled for assembly before it leaves the factor. The frame is set up on a concrete foundation or slab. Anchor bolts are placed in the concrete to provide solid fasteners for the columns. Because the column is a vertical member, a channel type base plate is used to secure the column in place. The anchor bolts hold the base plate, and the base plate is bolted to the base of the column

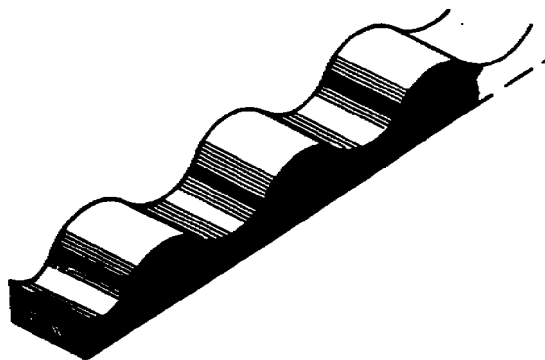

Figure 35. Rubber seal.

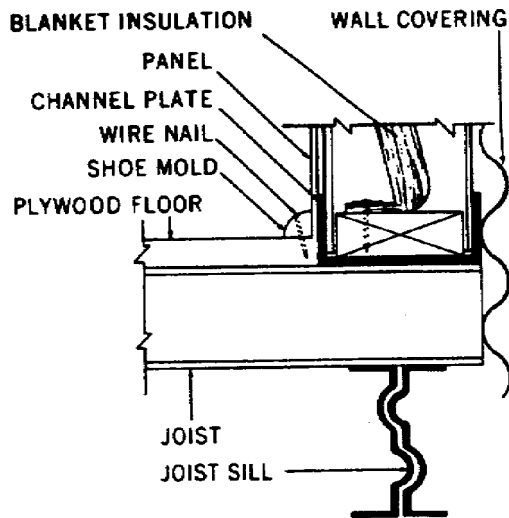

Figure 36. Exterior wall assembly.

5-12. Roof beams, extending from the top of the column to the peak of the roof, form the main supports for the roof. The roof beams follow the path of the common rafter and are joined at the ridge with splice plates and bolts. Splice plates are placed on the top, bottom, and sides of the roof beams at the ridge.

5-13. End wall posts, or door posts, extend from the foundation to the roof beam and are bolted in place at each end. Door framing is attached to the door posts. The door header is fastened to the door header girt, which extends between the door posts. A girt that extends from column to column across the end of the bay may also be used to secure the door header and tracks when a sliding door is used. A base angle (90° angle) is fastened to the foundation between the columns to provide a fastening surface for the vertical siding. The top of the siding is fastened to an angle that is attached to the roof beam. The eave strut provides a surface for fastening the top of the sidewall panels. The intermediate fastening surfaces are provided by horizontal girts on both end and side walls.

5-14. The sag rods, shown in figure 37, are used to prevent the girts from sagging between the columns. Sag rods are also used in the roof frame to help hold the purlins in line. The rods may be thin channels that clip in place and are not adjustable, or they may be threaded rods that can be adjusted. These rods should be kept tight, but overtightening will force the girts out of line and pull the screws loose in the siding.

5-15. Angles are installed vertically to frame louvers and windows. The angles for the louver form a frame in the upper part of the gable and provide a fastening surface for the louver frame

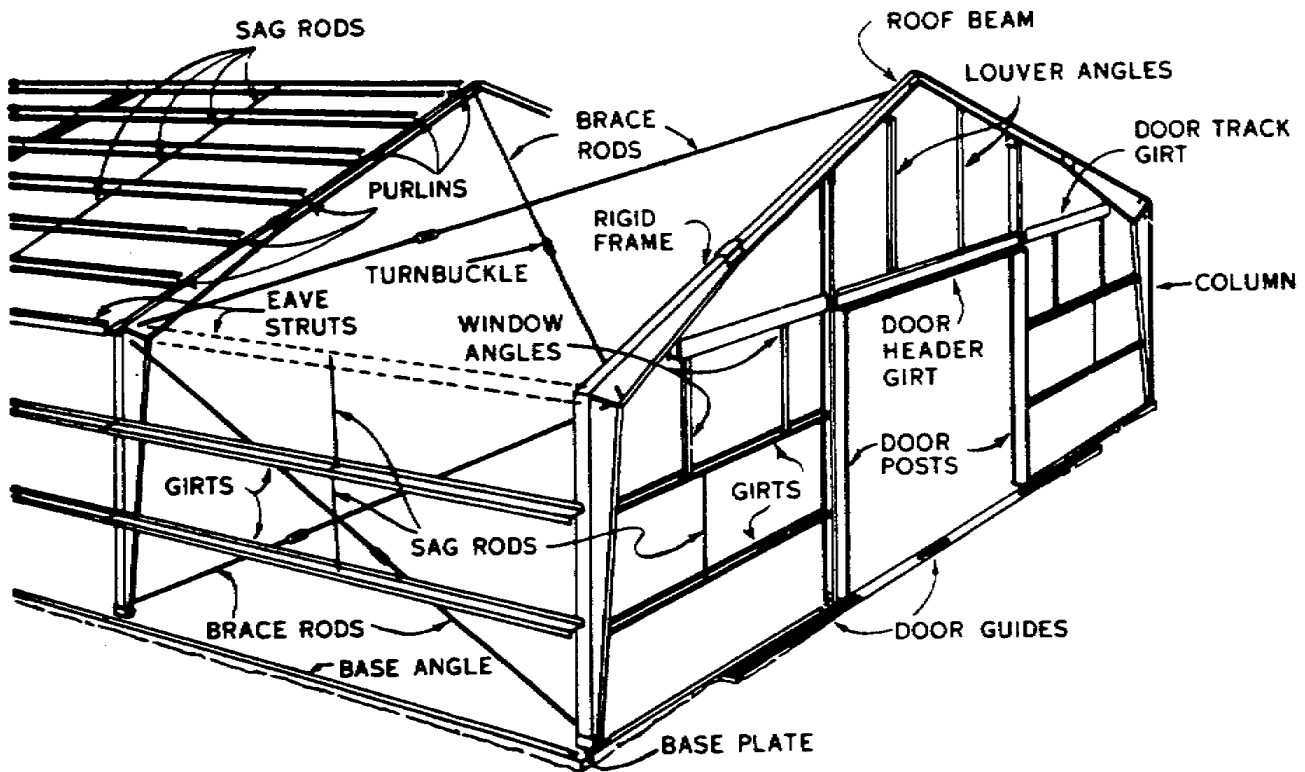

Figure 37. Prefabricated steel building.

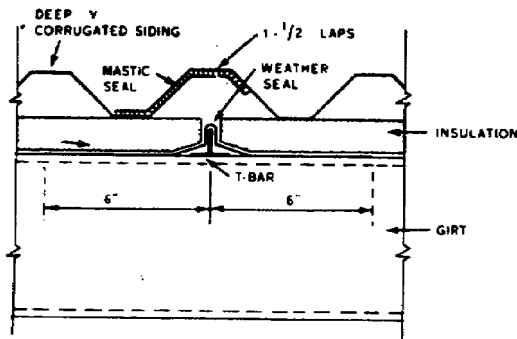

Figure 38. Deep V-wall panel.

and the siding. Angles also fit between the Z-shaped wall girts to provide a fastening surface for the window frame.

5-16. Notice the brace rods in figure 37. These brace rods are used to square the end bays of the building. The brace rods in the wall run diagonally from the top of one column to the bottom of the adjoining column. The rods pass through slots in the columns, and a bevel washer, flat washer, and nut are used on the ends of the rods. Turnbuckles are used at an intermediate point in the rod to provide for adjustment. The turnbuckle has a right-hand thread in one end and a left-hand thread in the other so that it can be tightened or loosened on each section of the rod at the same time. Adjustments may also be made by tightening or loosening the nuts on the end of the rods. When you tighten one rod, you must loosen the one that crosses it to provide for a shift in the framing. The brace rods between the roof beams serve to hold the bay square and must be considered if you adjust the brace rods enough to cause a shift in the frame.

5-17. Wall and roof coverings. The metal wall covering may be a panel that contains a

layer of insulation or it may be some other type of material. Figure 38 shows two insulated panels joined together with a vertical joint. With this type of installation, the T-bar is secured to the wall girts, and the metal weather seal is placed over the T-bar to provide a durable, moisture-proof joint. The insulation of the first panel butts against the weather seal, and the metal siding laps over the joint. The next panel has the insulation butted against the weather seal, and the metal siding laps over the previous sheet to form a lap joint of 1 1/2 laps. A mastic seal is applied to the area of the lap before the second panel is installed. This mastic seal is permanent and should never have to be replaced, except when the panel is replaced or the building is disassembled and relocated.

5-18. Another type of ribbed wall panel that has an insulated core is shown in figure 39. This panel has vinyl joint seals inserted along the edges. The vertical edges fit together as do those of tongue and groove boards to make a weatherproof joint.

5-19. The lap joint and the vinyl seal joint are the two common methods used to make weatherproof vertical joints in exterior walls. The mastic seal used in the lap joint of insulated panels is also used with sheetmetal siding and roofing. The mastic comes in strips with a moisture-proof paper backing that looks like masking tape. The strips are rolled like tape for easy handling. You unroll the tape and apply the mastic and backing on the joint area. Leave the paper backing on the mastic until you are ready to install the next panel. Just peel the paper off to expose the clean layer of mastic when you are ready to cover the joint. This mastic is also required in the horizontal joints of roof panels to prevent water from being blown under the top panel.

5-20. When horizontal joints are required in

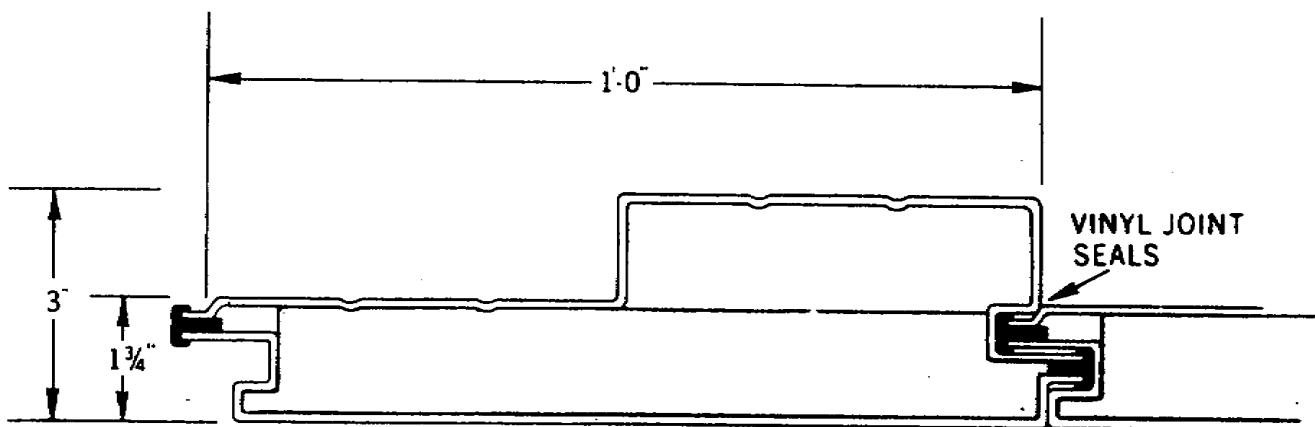

Figure 39. Ribbed wall panel.

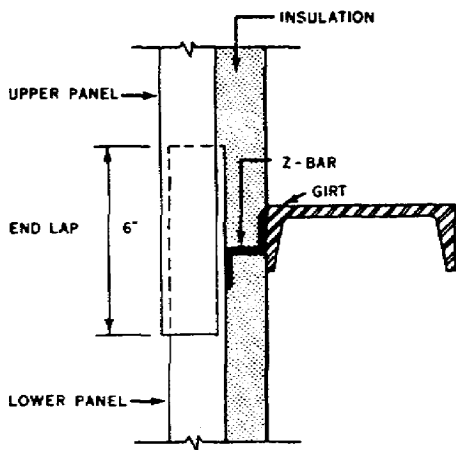

Figure 40. End lap of exterior wall panel.

a wall, they are formed by lapping an upper panel over a lower panel, as shown in Figure 40. A Z-shaped bar is used at the girt where the splice is made. The metal covering of the lower panel extends above the Z-bar, and the metal covering of the upper panel laps over the lower panel to form a 6-inch lap joint.

5-21. A solid rubber seal is used to make a waterproof joint where ribbed panels overlap a smooth surface. Figure 41 (A, B, C, and D) shows the shape of the rubber seals used with roof and wall galvanized sheet metal panels (A), aluminum ribbed panels (B), asbestos-cement panels (C), and corrugated glass panels (D). The seals are placed under the panel to prevent moisture from getting between the panel and the smooth surface.

5-22. Special rubber seals may also be used at eave struts, as shown in figure 42. Metal closure strips may be needed, in addition to the

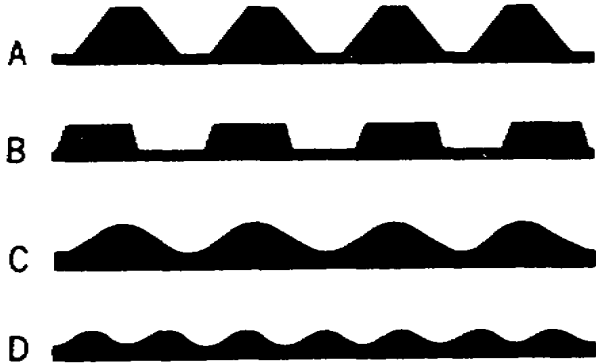

Figure 41. Rubber seals.

rubber seals, to close the space between the ribs of the panel.

5-23. Figure 42 also illustrates the type of information you can get from the master file of drawings in the drafting section. This drawing shows a side view of each part of the eave assembly. Each part is identified by shape, name, size, or type of material. Check the drawing file to locate hidden parts of the building so that you can plan your work accordingly.

5-24. Sheet metal siding is fastened to the girts, base angle, and eave strut or gable angle with self tapping sheetmetal screw. When fastening steel to steel, you can use steel screws or

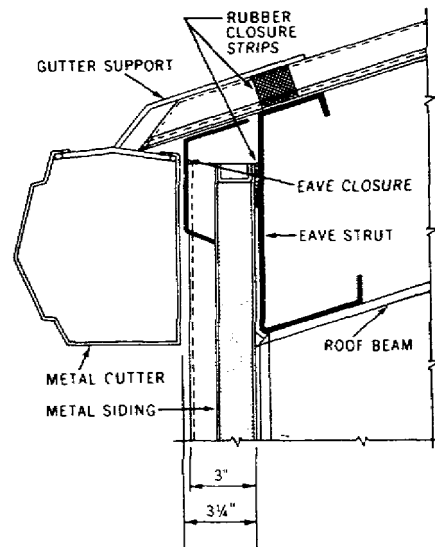

Figure 42. Eave assembly.

cadmium coated, rust resistant screws. These coated screws are also used to fasten aluminum panels to steel frames.

5-25. When aluminum panels are placed on a steel frame, some type of separator must be used between the different metals. This separator is usually provided by coating the steel (area of contact) with an asphalt paint. You can also use a layer of waterproof paper or asphalt saturated felt as the separator.

5-26. In metal construction, it is frequently impossible to prevent the contact of dissimilar metals. This contact may result in the corrosion of one of the metals and the protection from

corrosion of the other metal. This is the so-called galvanic action or electrolysis that occurs when metals of different position in the electromotive series are in direct contact in the presence of an electrolyte. The common metals used in construction are listed in the electromotive series in the following order: 1-aluminum, 2-zinc, 3-iron 4-tin, 5-lead, 6-copper. When any two metals in this list are in contact in the presence of an electrolyte, the one with the lowest number is corroded. Also, the farther the separation in the list, the greater the corrosion will be. Thus with iron and copper contact in the presence of water, the iron would be corroded more than lead in contact with copper under similar any condition. Any means that separates dissimilar metals will protect against this action.

5-27. Perhaps you are beginning to wonder how dissimilar metals can be used in layers as a single sheet of metal. Let's take lead-coated copper as an example. The lead coating on the copper is of a lower number value in the electromotive series and is affected by the corrosion while the copper is being protected from corrosion. Also, the two metals are consecutive (5 and 6) in the series, and a minimum amount of corrosion is anticipated. The purpose of the lead coating is to protect the copper; in this case, it protects it in two ways, physically and chemically.

5-28. *Doors and windows.* We have discussed the location and fastening of door post and window angles. Now let's look at the main units.

5-29. Metal doors are preferred for prefabricated metal buildings. There are two types of these doors. One type has an angle iron, steel, or aluminum frame and a single metal covering that serves as the exterior surface. The frame is exposed on the inside of the building. The other type of metal door has a metal frame with a metal covering on each side. This door is built

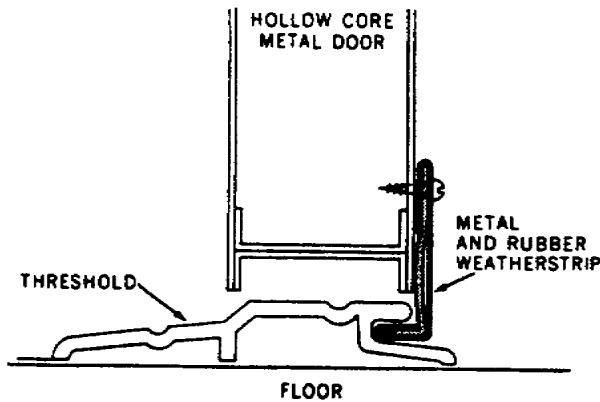

Figure 43. Weatherstrip installation.

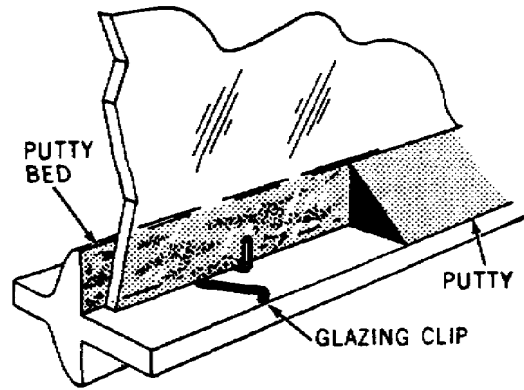

Figure 44. Glazing metal sash.

like a flush door and may have either a hollow or insulated core.

5-30. Metal doors seldom need repairing and maintenance usually consists of tightening the bolts that hold the lock in place, or tightening or replacing screws in the hinges and weatherstrip. Occupants usually correct the problem of loose screws and bolts, but you will probably be called on to supply new or larger screws. When retightening of screws is required at frequent intervals, you should substitute a screw that is one size larger than the old one or relocate the hinge and make new screw holes. The weatherstrip on the jamb causes very little trouble, but the strip along the bottom of the door may get damaged or become loose. This threshold strip extends beyond the lower edge of the door and hooks into a groove in the threshold as shown in figure 43. Make sure that the strip is adjusted so that it fits into the groove. This type of threshold and weatherstrip is common in exterior doors that swing over a concrete floor.

5-31. Window maintenance consist of tightening the mounting screws in the frame, side panels, and the U-shaped drip channel (gutter). Replacing glass in a metal sash is a little different than working with a wood sash. When you remove the old putty from the sash, you must locate and save the metal glazing clips. Look at the glazing clip shown in figure 44. This clip fits between the edge of the glass and the frame. One end of the clip fits into a hole in the frame, and the other end hooks over the edge of the glass. Allow for the thickness of these clips when you cut the new glass. Place a bed of putty on the frame and press the new glass gently against it. Use a screwdriver to install the glazing clips. The clips will hold the glass in place while you are applying the beveled layer of putty around the edge of the glass.

5-32. Any other problems you encounter when repairing prefabricated buildings can be solved by using the information you have learned about other types of buildings. We will therefore move on to the discussion of construction of prefabricated buildings for temperate, tropic, and arctic regions.

6. Construction of Prefabricated Buildings for Temperate, Tropic, and Arctic Regions

6-1. Prefabricated buildings are constructed and standardized for use in Temperate, Tropic, and Arctic regions. This is done to save time and material, as well as to simplify erection.

6-2. **Construction for Temperate Regions.** All of the prefabricated buildings discussed in sections 1 and 2 in this chapter were constructed for use in temperate regions. No special factors are needed for standard prefab buildings for temperate climates. The construction plans for a temperate climate specify minimum requirements. The floors can be earth, wood, or concrete, depending upon the purpose of the building.

6-3. **Construction for Tropic Regions.** The floor plans for prefabricated buildings for tropical climates are made to provide as much air circulation as possible. Most buildings designed for tropical climates have wood floors, which are

raised above the ground to insure dryness and to prevent mildew and the entrance of insects. The use of continuous screened openings, such as ridge vents and floor level vents, provides as much ventilation as possible consistent with the shelter that is required. Overhanging eaves shield these openings from the direct rays of the sun and afford some protection during rainstorms. For protection against termites, all wood members touching ground surfaces are covered with a metal shield. Standard prefabricated buildings are designed to resist normal wind forces. However, in areas where high wind velocities occur, all buildings should be anchored by cables or guys rather than by modifying the buildings themselves.

6-4. **Construction for Arctic Regions.** The extremes of Arctic weather will require modification of the standard prefabricated building normally used in a temperate climate. Two major modifications include the use of floors that are of double thickness and of walls and roofs that are insulated. Heat is supplied by individual stoves or heaters. The door and window openings are small-only large enough to provide adequate ventilation and passage. The roof framing is designed for snow loads of 15 pounds per square foot. When it is impossible to clear heavier snow from these roofs, the roof framing must be strengthened.

CHAPTER 3

Heavy Timber Construction

THE FOOD YOU EAT in the mess hall, the items you buy at the PX, and the clothes you purchase at the sales store—all these were at one time shipped to and stored in a warehouse. To make the handling of these items by warehouse personnel easier, most warehouses are constructed with loading docks or platforms. It is important that these warehouse loading docks or platforms be well constructed and maintained to prevent their breakdown. You, as an Army carpenter, will be responsible for the maintenance of these facilities, and this chapter will help you do the job.

2. This chapter also deals with waterfront structures. Naturally, we think of the Navy when we think of wharves and piers. Yet there are places where Army personnel maintain such facilities.

3. A good example of this is our port facilities in Vietnam. These facilities were expanded at first but most of them have been completely rebuilt to accommodate all the services. Some of these facilities may be used by the Navy for its tankers and supply ships which bring in fuel, food and other necessary supplies. The facilities engineer, or an engineer unit under Army command, is responsible for all maintenance and repair work to keep facilities in operating condition. This is only one example—there are many others—where you may have the opportunity to work on wharves or piers. Some may be large, like the example just given, or they may be small, only large enough to accommodate small boats. This chapter discusses the fundamental principles of constructing and maintaining warehouse loading docks and waterfront structures.

7. Warehouse Loading Docks

7-1. Practically every item we see around us was at one time packed and crated or stored in a warehouse. Some of these items are large, heavy, and very difficult to handle. To make them easier to handle and store, warehouses have been

constructed with heavy-duty loading docks. Some docks are constructed with inclined ramps (see fig. 45) to accommodate small loading and unloading equipment. Others are built upright for direct loading or unloading of trucks and rail cars. No matter what type loading dock is provided, it must be strong enough to withstand the impacts of loaded trucks and movements of loading equipment. To make sure these structures can withstand this abuse, they must be periodically inspected and adequately maintained.

7-2. **Construction Features.** This section contains information on the construction features, general maintenance problems, and corrective repairs of warehouse loading docks. There are two important factors to consider when planning loading docks: the size of cargo to be handled and the weight to be carried by the platform. For example, if only small, light items of cargo will be stored in the warehouse, the dimension of the loading dock may be small. But if the platform is to carry the weight of cargo and transporting vehicles (forklifts, tugs, and trucks), it must be built much larger and stronger than if it is to

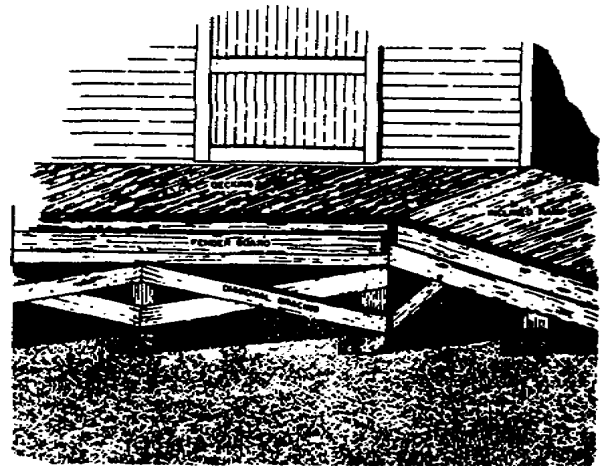

Figure 45. Warehouse loading dock.

carry only the weight of cargo. For this reason, we will discuss the different types of foundations and how they should be constructed to adequately support the intended loads.

7-3. *Foundations.* Normally, loading dock foundations are constructed of either wood and masonry piers or columns. These columns or piers must be spaced according to the weight they are to carry. In most cases, however, they are spaced from 6 to 10 feet apart.

7-4. If the earth on which the foundation is to rest has low supporting strength, or if the loads are expected to be extremely heavy, the foundation should be constructed as a solid, reinforced concrete wall.

7-5. *Sills.* Sills consist of single heavy timbers or buildups of two or more timbers. Sill sizes will be determined by the intended loads to be carried and the distance between piers. Consequently, sills are used with pier type foundations and are placed directly on the pier. If sills are correctly placed, they will surround the perimeter of the dock. After the sills are tied to the piers, girders (if needed) are placed.

7-6. *Girders.* Girders are used as interior foundation walls to support the inner ends of floor joists. However, they will not be needed if joists safely span the distance from sill to sill. If girders are not used, joists should be placed directly on the sills.

7-7. *Joists.* Joists are the lighter pieces which make up the body of the floor frame. We don't mean that they are actually light in weight but that they are light in comparison with the other framing members. Joists are usually 3 inches thick, but thicknesses will vary to suit the construction details. They are usually spaced from 16 to 24 inches on-center. However, if this spacing is too wide to support the intended load.

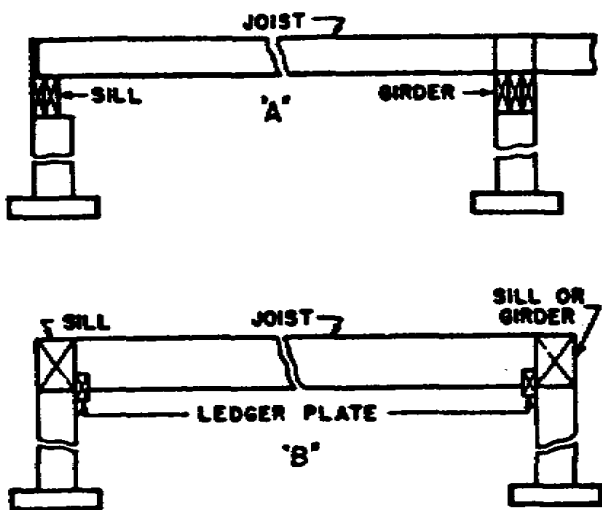

Figure 46. Joist construction

you should use a heavier joist rather than narrow the spacing. When joists are being placed, make sure that the greatest bearing surface is used. In other words, place them with the crown edge up.

Placing the crown edge up will tend to counteract the bending force imposed on the joist. After each joist is placed, it should be secured, as indicated in figure 46.

7-8. *Bracing.* If we expect loading docks to adequately support the loads placed up on them and to withstand the abuse from vehicles, we must reinforce them with some type of bracing.

This bracing must be properly designed and placed to give the support desired.

7-9. If wooden piers are used as a foundation, they should be braced to each other with diagonal braces, as shown in figure 45. If wooden girders are used in the platform construction, a truss brace should be placed under each girder. If the platform is to support extremely heavy loads.

bracing should be secured with bolts. On the other hand, light load carrying platform bracing may be secured with spikes. No matter what method you use to secure the bracing, make sure that the materials used have good bearing qualities.

7-10. *Decking.* Decking, or flooring, used on loading docks should be at least 3 inches thick and laid perpendicular to the joists. All joints must be staggered and joined directly over a joist. After decking has been correctly fitted and placed, it should be secured with large spikes.

7-11. After the platform has been erected and properly floored, it should be protected from unnecessary bumps and scrapes. This protection is supplied by fender boards.

7-12. *Fender boards.* Fender boards are heavy timbers placed in front of the loading dock to protect it from vehicle contact damage. They are secured to the sills with spikes or bolts, depending upon the size of the timbers. If adequately placed, fender boards form a solid, continuous row of timbers.

7-13. **General Maintenance Problems.** Your job is not complete when you finish the construction of the warehouse loading dock. There is a continual maintenance problem, and it is your job to perform this maintenance. Aside from original flaws in materials, structural sealing, weathering, and normal wear and tear, deterioration presents our most extensive maintenance problem. Deterioration is caused by decay (fungi action), rust (chemical action), and insects (termites and marine borers).

7-14. *Decay and its prevention.* Unpainted or untreated wooden members are more subject to decay than any of the other construction materials. Warm, humid climates or seasonal periods

of high humidity (moisture content) provide excellent conditions for the growth of decay-causing fungi. Wooden members which are near, touching or set in damp ground are especially subjected to fungi growth. To prevent or minimize this fungi growth is our job if we expect maximum service from our wooden structures.

7-15. Exposed wooden members should be painted or soaked with creosote. Whenever possible, wooden members should be constructed on some type of masonry foundation and above ground level. This holds true for treated as well as untreated timber.

7-16. *Rust and its prevention.* Iron and steel components will rust after prolonged periods of exposure to rainfall, snow, or moisture-laden air.

This is particularly true if the metals are not painted or otherwise treated against this type of reaction. Paint metals which are not inherently resistant or otherwise protected from rust.

7-17. *Insects and their elimination.* Where wooden structures are concerned, termites present a major inspection and repair problem. If these insects establish themselves in or beneath a structure, they construct earthlike shelter tubes which lead to the wood portion of the structure. These tubes may enter the wood from below or through cracks between brick or hollow tile.

A well-established termite colony can cause major structural damage in a very short while. For this reason, we must provide an adequate insect control program.

7-18. Some of the basic methods used to discourage termite infiltration are soil treatment, wood treatment, termite shields, not allowing wood to come in contact with the ground, and preservative treatment of supporting wood piles. Special detail in foundation construction will also discourage termite activity. However, if termite colonies do accumulate, consult your entomologist.

7-19. *Corrective Repairs.* These maintenance problems can and do create serious situations; however, if they are adequately approached and treated, the seriousness will be reduced. Proper inspection and maintenance methods will prolong the useful life of all structures.

7-20. To determine the best repair method depends upon the use of the structure, extent of damage, life expectancy, and its possible future use. These are very important factors, but why repair are needed is also important. The extent of damage will depend upon why or how the structure failed. To determine this we must know the causes for failure.

7-21. Premature failure of materials and various components may be caused by one of the following reasons:

- a. Defective materials or structural components.

- b. Incorrect installation or application.
- c. Failure of related, connected, or adjacent component.
- d. Faulty design.
- e. Unusual or extreme climatic conditions, exceeding the design specifications for which the material or structural part was de-

signed.

- f. Use exceeding the limitations of original design.
- g. Use other than that for which the structure was designed.

7-22. If failures occur during the normal life expectancy of the structure, they should be carefully investigated and the defects corrected before any superficial repair is done. Unless the causes of these failures are identifiable or corrective procedures are standard, the installations engineer should be consulted for adequate corrective measures.

8. Waterfront Structures

8-1. The fundamental principles and practices presented here are meant to assist you in the preservation of waterfront structures in the most economical manner. These fundamentals are intended to insure that facilities are maintained in such a condition that they can be used throughout their planned life. These structures would be maintained by an Army carpenter, if that carpenter was assigned to one of the waterfront installations maintained by the Army.

8-2. If a carpenter is expected to maintain waterfront structures, he must know what these structures are, the terms used in working with them, what damages them, the preventive maintenance methods, and the inspection and repair procedures used in conjunction with them. Let's discuss these methods and procedures.

8-3. Generally speaking, waterfront structures include wharves, quays, pier bulkheads, retaining walls, breakwaters, jetties, groins, and other supporting features. However, wharves, quays, piers bulkheads, and retaining walls are the only structure that we will be working with; so we will center our discussions around them. This section covers the construction features, special tools needed, general maintenance problems, corrective repairs, preventive maintenance measures, and safety measures for waterfront structures.

8-4. Wharves and quays are structures constructed parallel or approximately parallel to the shoreline which provide berthing or docking for seagoing vessels. These structures are virtually

the same and, from this point, will be referred to as *wharves*.

8-5. Piers are structures constructed perpendicular or approximately perpendicular to the shoreline which provide berths and slips to tie up, or moor, vessels on either side.

8-6 Bulkheads and retaining walls are structures constructed approximately parallel to the shore to protect the shore from soil erosion.

8-7. Wharves and pier must be maintained to the extent necessary to insure safe and efficient use for berthing, servicing, repairing, and overhauling seagoing vessels. The principal jobs of maintaining these structures are as follows:

- a. Replacement of broken or damaged fender piles.
- b. Replacement of deteriorated wood decks and stringers and other timbers affected by attacks of marine borers.
- c. Replacement of corroded and deteriorated pipe.
- d. Removing scale and repainting steel member.
- e. Repairs to pavement deck surfacing.

8-8. There are several terms specifically applicable to the maintenance and repair of waterfront structures and harbor facilities. Some of these terms and their definitions are as follows:

BITT--A double post to which vessels are moored, or tied.

BOLLARD--A single post to which vessels are moored, or tied.

CHOCK--A block with two horn-shaped converging arms used to guide lines. It is sometimes called a *fairlead*. A chock is also considered a horizontal timber fitted between two vertical fender or fender piles.

CLEAT--A horizontal device with two diverging arms to which mooring lines from vessels are fastened.

DOCKS--Sheltered basins in which vessels are berthed or docked.

DOLPHIN--Usually a cluster of piles placed in the water for mooring vessels or keeping them away from structures, shoals, or shores.

FENDER--A structural feature used to lessen the shock or minimize the damage when vessels come in contact with shore structures.

MOORING--Facilities to which vessels are safely secured. They include mooring platforms or islands, dolphins, piers, wharves, etc.

PIERHEAD LINE--An established harbor line marking the permissible limit of pier construction. This is usually limited to open type construction.

QUAY WALL--A wall along the shore to retain the soil. It may be used as a wharf; however,

when used as a wharf, it becomes a quay, or marginal wharf.

SEAWALL--A wall along the shore to prevent encroachment (enter by gradual steps) by the sea. But if the wall is used as a wharf, it is not called a seawall.

SLIP--The area between two piers.

8-9. Wharves and piers are constructed from timber, concrete, steel, or a combination of these materials. Usually, timber is the most widely used, because it is more economical, lighter, and easier to work. However, the serviceable life of timber is shorter than the others, because it is subject to decay by fungi action and deterioration by insect infestation. Its life can be extended by protecting it with a preservative. For the most part, creosote treatments are very effective against these actions.

8-10. Before any waterfront structure is constructed, there are many factors to be considered. Among these factors are:

- a. The sizes of vessels to be accommodated.
- b. The amount of cargo to be handled.
- c. The loads (dead and live) to be carried on the structure.
- d. The depth of the water.
- e. The variations in tide.

8-11. **Construction Features.** To make sure that our wharf or pier can absorb the abuse, we must use the type of construction components recommended.

8-12. **Pilings.** There are three types of piles used for wharf and pier construction: bearing pile, fender pile, and mooring pile. If timber is used as piling, it must be treated with creosote or some other preservative compound to protect it from fungi and marine borer attacks.

8-13. Bearing piles support the wharf or pier framework and decking. The piles should be straight and measure at least 6 inches across the top, 18 inches across the butt (bottom), and from 60 to 80 feet in length. The length varies according to the depth of the water and condition of the bottom. These bearing piles should be spaced from 6 to 10 feet apart, center to center, in one direction and 5 feet apart, center to center, in the other direction.

8-14. The force of a moving ship (coming in direct contact with bearing piles) is sufficient to collapse a wharf if the pilings are not protected. To furnish this protection and to absorb the initial shock, fender piles are placed approximately 2 1/4 feet out from the centerline of the outside row of bearing piles. These piles are placed approximately 18 feet apart and along the sides where the ships dock.

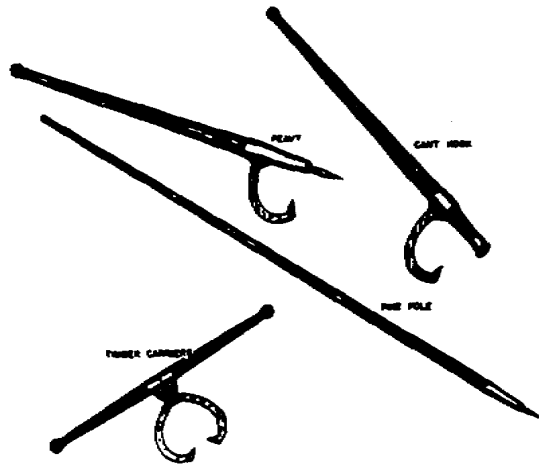

Figure 47. Logger's tools.

8-15. The third type of piles, mooring, is placed in line with the outside row of bearing piles, spaced

approximately 30 feet apart, and braced along the outside row of bearing pies.

These piles usually extend about 4 feet above the floor, or deck, of the platform. The 4-foot extension provides ample space to secure mooring lines.

8-16. *Caps and girders.* Caps are large timbers which are placed on top of the bearing piles to support pier girders. They are secured to the piles with driftpins (steel pins which hold timbers together). Pier girders rest on the caps and are secured to the caps with driftpins. Girders for wharf construction, however, may rest directly on the bearing piles. These girder are also secured with driftpins.

8-17. *Joists.* Joists are smaller timbers (like 8x12-inch) to which the flooring, or decking, is secured. They rest directly on the girders and are secured to them with driftpins. Joists are very important and should be constructed of well-seasoned well-treated timbers.

8-18. *Decking.* Decking, or flooring, should be laid perpendicular to the joists and secured with sixty-penny (60d) nails or driftpins. This deck-

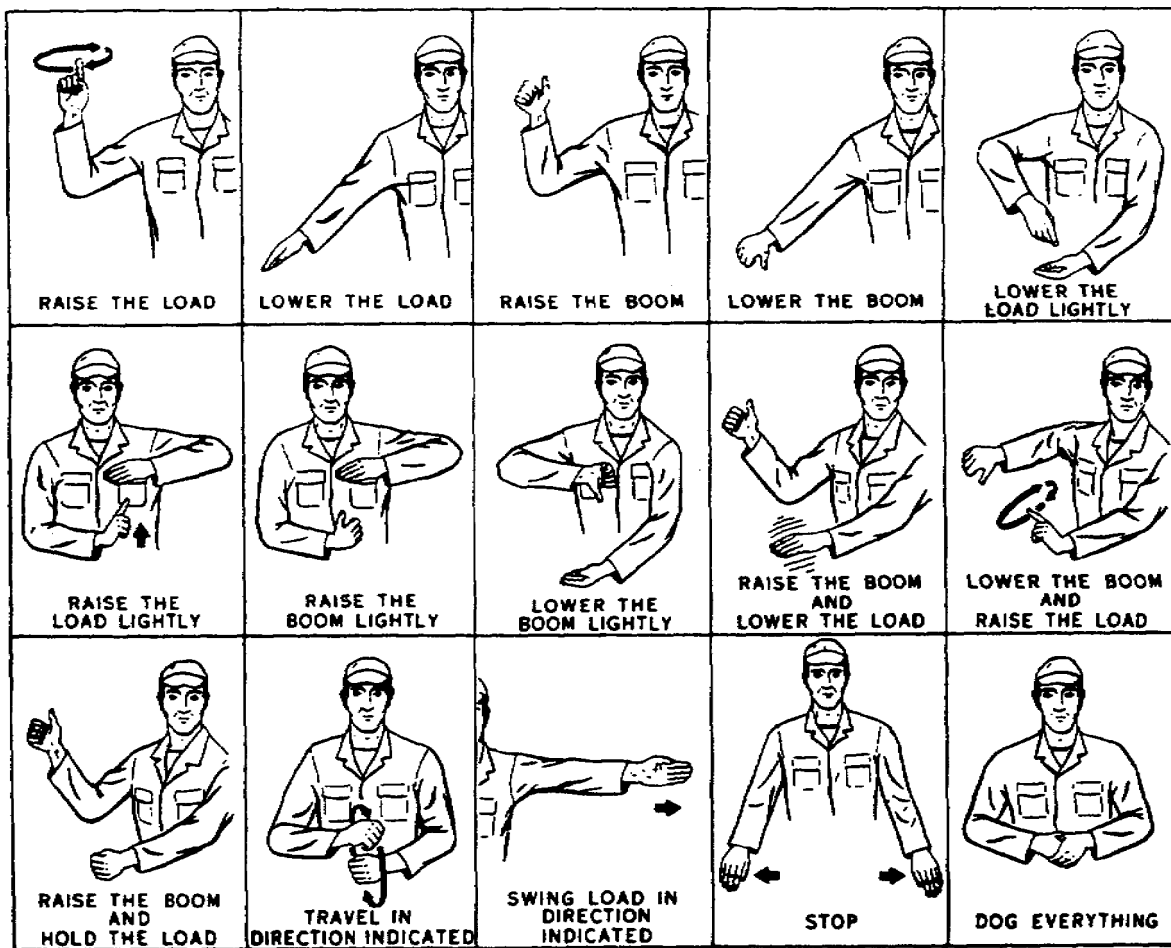

Figure 48. Standard crane signals.

ing should be at least 3 inches thick and joined directly over the joist. The joints should be staggered for greater strength and support.

8-19. **Special Tools Needed.** Since you cannot manhandle all of the heavy timbers you will be using to build waterfront structure, special tools are used to move and place these timbers. They are known as logger's tools and consist of peavys, cant hooks, timber carriers, and pike poles. The peavy and cant hook are lever type tools and are primarily used to roll timbers. Timber carriers are considered two-man tools; they are primarily used to pick up and/or carry timbers. Pike pole are used to hold or steady timbers while they are being placed. These tools are shown in figure 47. Although the cane cannot be considered a special tool, we include it here because it is used to raise and lower heavy timbers, such as are used in the building of waterfront structures. Normally, two men are assigned to the crane: the operator, and the helper. The helper drives the crane carrier (truck), hooks and unhooks loads, and signals the operator when to lift and lower the load and where to position the load. Standard signals are used for these purposes. You will not be called upon to operate the crane; but there will be times when the crane helper is not available, and at such times you will probably have to help the crane operator with the signals. You will probably be working with the standard crane signals, illustrated in figure 48. Study and learn the signals thoroughly, because if you give the crane operator an incorrect signal, it could cause an accident that would damage some very expensive equipment. Remember, after the heavy timbers have been moved and placed, they must be leveled properly. The carpenter's level, which you learned about in Memorandum 531, is the tool used for this purpose.

8-20. Let's assume that you are going to remove and replace some damaged wooden pier component. Before you can replace the component, you must prepare them by boring boltholes, notching for special fits, etc. Also, you must know and use certain types of timbers, equipment and specifications. What are some of these things you should know?

8-21. These items of information are called *General Notes* and are found on the construction plan. They should be used any time you construct a new structure or repair an existing one.

From these notes you will get such information as the size hole to drill for driftpins and bolts, how bolts should be placed, basis of design, type of hardware to use, etc. Let's take a look at a sample General Notes legend.

General Notes

Holes for driftpins (D.P.) shall be 1/16" smaller than the pin itself.

Holes for through bolts shall be the same diameter as the bolt itself.

No bolthead should project beyond face of timber on outside face of fender system.

All piles must be creosoted if they are to be used where marine borers are active.

All lumber must be rough except 4" plank decking, which shall be finished on wearing side only.

Basis of design:

Live load--500# per sq. ft.

Pile bearing value--50,000#

Gantry crane--17-ton capacity.

Extreme fiber stresses--wood, 1800# per sq. in.

Compression parallel to grain--wood, 1500# per sq. in.

Compression perpendicular to grain--wood, 450# per sq. in.

Horizontal shear--wood, 15# per sq. in.

Modulus of elasticity--wood, 1,600,000.

Use O.G. cast iron washers with all bolts.

The length of pile as listed in "Bill of Material" assumes a penetration of 15'. The penetration required should be determined by driving tests and the length of piles adjusted accordingly.

Projecting ends of all bolts should be peened after nuts are tightly drawn.

8-22. Let's take a look at some of the problems of general maintenance of waterfront structures with which those, like you, in the specialized carpentry field should be familiar. To begin with, what are the primary causes of pier or wharf construction failures?

8-23. **General Maintenance Problems.** Chief among the general maintenance problems resulting from pier or wharf construction failure are the same causative factors as those that damage warehouse loading docks. To these can be added storms, collisions, and marine borers.

8-24. Deterioration is also responsible for some pier and wharf failures. This deterioration may be anticipated and corrected as outlined below. It is caused by decay and the action of termites and marine borers. Decay, turn, caused by the action of low parasitic forms of plant life known as fungi. The growth of these fungi depend upon moisture, food, air, and temperature (warmth). Consequently, the absence of any one of these requirements will prevent fungi growth. However, the most general and successful way to stop fungi growth is to poison the food supply. We usually poison the food supply by treating the timber itself with creosote.

8-25. Termite attacks on structural building timbers are probably the chief causes of insect damage. This is specifically true of timber components which are in direct contact with the earth. Although termites are the chief causes of damage, they are not the only damaging insects.

Marine borers are also responsible for some of the deterioration actions on timbers.

8-26. There are many types of marine borers, but only two general groups (mollusks and crustaceans) are important to us now. Borers belonging to the mollusks group enter the timber, burrow themselves, and honeycomb the interior. On the other hand, the crustaceans operate by forming shallow gullies just under the surface.

8-27. Wharf or pier construction failures are caused either by mechanical factors or by deterioration factors. No matter which is responsible, the damage must be repaired. So let's take a look at some of the corrective repairs which can be made and try to determine which method we should use to repair any particular damaged pier.

8-28. **Corrective Repairs.** Wharves and piers are usually repaired by replacing the damaged part. The replacement part should be of the same type of material as the part it is to replace. But, if failure is due to overloading and if it is believed that overloading will recur, the structure should be reinforced or otherwise strengthened.

8-29. Failures by deterioration are the hardest to detect and correct. Failure to correctly estimate how far repairs should be carried out is one of our biggest errors. This is specifically true if the failure is due to deterioration. From a visual inspection, some timbers look solid and sound; but when removed, they may be found to be hollow shells. This is primarily due to attacks by termites. Similarly, fender pile which are sound above the water line are often damaged near the ground line by marine borers. For these reasons, all timbers must be carefully checked to determine their true condition. Two ways to do this are to hammer on timbers or to drive nail into them to see whether they have become softened by deterioration. If you have doubt as to the soundness of a structure, you should bore holes into the sides of caps and stringers. If you find the timber to be sound, carefully plug and paint the holes to keep out further moisture.

8-30. Generally speaking, the materials used for repairs or replacements should be of the same type and size as those used in the original design. However, no matter what type of materials are used, you must handle them with care if you intend to get maximum service. Also, to stop the entrance of fungi and insect, you must re-treat all low-resistant areas and broken surfaces of treated timbers. If cuts are made in the surface of treated timbers, you should paint them with two or more coats of preservative compound. Now, if creosote is used for this

treatment, it must be applied at some temperature between 175° and 200° Fahrenheit. Another thing to remember is to avoid the use of timber hooks, cant hooks, or other sharp-pointed tools when you are handling treated timbers.

8-31. Most of our modern treatment plants precut timbers to size and notch and bore them before treatment. This prevents the need for further treatment if you handle these timbers with care.

8-32. So far, we have discussed the construction features of wharves, piers, and quays; the special tools needed for such work; the general maintenance problems involved here; and the corrective repairs necessary. Now let's talk about some of the ways to prevent or minimize damage to these structures and safety measures which you use in such work.

8-33. **Preventive Maintenance Measures.** To adequately maintain wharves and piers, we must provide and maintain an appropriate preventive maintenance program. This program must outline preventive measures and present specific frequencies for inspections and corrective actions. Therefore, we are going to discuss the methods you should use to maintain these structures. As we have explained above, wharf and pier structures are damaged from wear, deterioration, insect infestation, overloading, storm damage, fire, etc. However, the damaging effect from these factors can be minimized if we follow the procedures and precautions outlined in the following paragraphs.

8-34. To guard against excessive wear to decking, we must make frequent inspections and keep tracked vehicles or other iron wheeled equipment from traveling over it. Post notices of this restriction in conspicuous places. All loose bolts and nuts found during the inspection should be tightened. All decking should be securely nailed at every joist. If decking is 3 inches thick, 60d nails or 6-inch spikes should be used. If it is 4 inches thick, 7-or 8-inch spikes should be used. All planking used as decking material should be of the same thickness to give a smooth surface.

8-35. Fender piles should be removed and replaced before excessive wear occurs. Normally, only hardwoods (such as oak) are used for fender piles; however, if traffic is light, creosoted softwood piles may be used. No matter what type of wood is used, make sure that all chocks are tightly fitted between the piles. These chocks help prevent the piles from rolling when rubbed by vessels. If currents are swift, fender log should be used to prevent damage to piles. Also, a thorough check of all timber and hardware should be made and any necessary corrective actions taken.

8-36. If fender piles should break, serious damage can be done to the structure by the impact of vessels; therefore, all fender piles should be replaced at regular intervals.

8-37. The anticipated normal life of fender piles will vary in different localities, depending upon the type of pile, water and soil conditions and other factors. Anticipated normal life can be established with reasonable accuracy after a few years or by observing other similar structures in the vicinity. After the anticipated normal life has been established, every replacement pile should be numbered and a historical record kept on it to make sure that it is replaced before the end of its anticipated life.

8-38. **Safety Measures.** When any type of work is performed on a wharf or pier structure, the following safety precautions should be observed:

- Make sure all safety provisions are applied when ladders, runways, platforms, scaffolds, and guardrails are used.

- See that all equipment is inspected by some qualified person and is found in safe operating condition before it is used.

- Don't permit workmen to ride loads, hooks, hammers, material hoists, buckets, or any type of moving equipment.

- Don't allow loads, booms, or buckets to be swung over the heads of workmen.

- Require all workmen to wear life vests when they are working over water, unless proper scaffolds, platforms with guardrails, or safety belts and life lines are provided.

- Insist that workmen wear protective clothing, goggles, or other safety equipment required by the type of work being done.

- Make sure that all provisions covering storage of materials and disposal of waste are adequately followed.

CHAPTER 4

Sawmill Operation

THE NUMBER Of Army people serving in Vietnam has increased tremendously since 1965. As a result, facilities construction--quarters, offices, depot, hangars, etc.-has been a major problem. It is your job to relieve this and similar problems, because as an Army carpenter, you will be building the facilities needed.

2. It take much hard work to build a building when the lumber is available. In your job in the Army, in places like Vietnam, there will probably be times when the lumber is not available. If you run into this situation, your job will be twice as difficult, because you will have to go into the jungle and cut the lumber. For you to be able to do this job, you must know how to erect and operate a sawmill.

3. This chapter discusses erecting sawmill, building log skidways, operating sawmills, and caring for large cutting saws. It also discusses the important rules in sawmill operation.

9. Erecting the Sawmill

9-1. Most of your sawmill work in the Army will probably be performed with a portable sawmill. One of the many different types of portable sawmills is shown in figure 49. Usually, a portable sawmill is erected (set up) once a day and it very seldom remains at one setup over 2 days. It is preferable to move the sawmill away from the material accumulated rather than to move the lumber, slabs (the outside pieces, with or without the bark, taken from logs in sawing them into boards), and sawdust. On large setups the sawmill is simply moved ahead progressively to other skidways and away from the accumulated material. After you set up a sawmill two or three times, you should be able to set it up in a short length of time.

9.2. To erect the main frame of the sawmill, place it within a few feet of the location where you intend to operate it. Then you can prepare the exact location and move the mill the few feet into place. If the sawmill is mounted on pneumatic tires, dig a shallow trench in

front of each wheel on level ground. This is done so that when the sawmill is leveled up, some of its weight will be removed from the tires. If this is not done, the sawmill will not sit rigidly enough. Pull the sawmill ahead to fit into the trenches. Be sure that the sawdust conveyor does not rest on the ground when the sawmill is pulled into the trenches. Unhitch the truck or power unit from the sawmill and place it in a relative position to the sawmill that will let you align the drive belt from the power unit to the sawmill.

9-3. **Leveling.** The sawmill must be leveled properly. If it is not level, the saw will run "in" or "out at the front. A saw that runs "in" at the front will make the last piece of lumber cut (the dog board) thin at the top. A saw that runs "out" at the front will make the dog board thick at the top. In other words, the lumber will not be square. When you level the sawmill, be sure that some material, such as a plank or timber, is placed on the ground underneath each leg to prevent it from settling into the soil as the operations proceed. To level the sawmill properly, you must consult the operator's manual for the particular make and model you are using.

9-4. **Bracing.** After you have leveled the sawmill correctly, brace it securely to compensate for drive belt tension. Most portable sawmills are braced by securing a brace against the frame of the sawmill and to the ground or power unit. In addition to bracing the sawmill, you must also set up the sawdust conveyor chain and anchor it. On most sawmills, this chain is anchored by driving an iron pipe or strong pole into the ground. To brace the sawmill properly and to anchor the sawdust conveyor chain, you must also consult the operator's manual for the particular make and model you are using.

10. Building Log Skidways

10-1. Before you erect the sawmill, you should line up your sawing sites before you start sawing the lumber. This is done to determine the exact

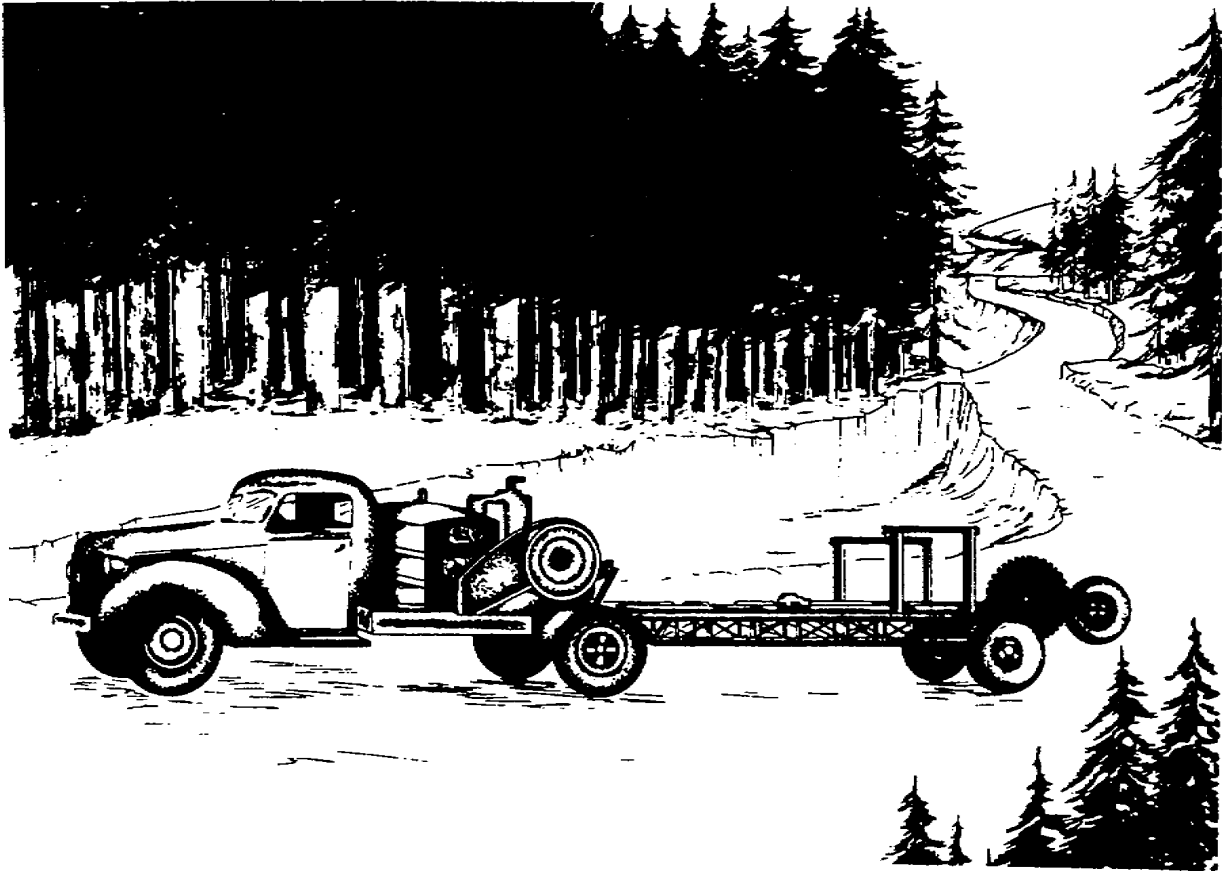

Figure 49. Portable sawmill.

location of the logs, to ascertain the accessibility by truck, and to check the skidway. A skidway is a platform made of skids on which logs are piled for loading. If possible, skidways should be made on a gentle slope where there is enough space to pile lumber, slabs, and sawdust. A skidway is shown in figure 50. Skidways are installed on gentle slopes so that the lumber and slabs are carried downgrade. This procedure decreases the labor involved tremendously. It is also advantageous to have logs piled on one rollway, because most portable sawmill carriages are not equipped to take on logs from two rollways. Logs are usually received on the carriage with the butt-end toward the saw.

10-2. Sometimes a tractor with a fingerlift can be used to great advantage with a portable sawmill. It can be used to load and even turn large logs at the skidway, and load lumber on trucks. In large commercial operations, or where the timber stands are thick and the logs large, portable sawmills can be used in pairs. A tractor with a fingerlift can be kept busy at the skidways, at the slab piles, and loading lumber at the trucks. This is a good method to use when you are short of personnel, because the need for quite a few men can be eliminated by this method.

11. Operating the Sawmill

11-1. Now that you have erected the sawmill and have built the log skidway, you are ready to operate the mill. But before you attempt to operate the sawmill, you should acquaint yourself with the operator's or sawyer's position and stance on the carriage. This familiarization will give you the feel of the moving carriage and allow you to make the movements most natural to you.

11-2. You must also acquaint yourself with the relative dimensions of the sawmill carriage. Give special attention to the length and distance between the head blocks (blocks under the head of the log to raise it), because this information will help you position the carriage properly to receive the log that is approaching on the skidway. This positioning of the log on the carriage cannot be overemphasized. No set rule can be given, because all logs are different, but you should always strive to work with the center of the log in the center of the carriage. You will feed the saw from the operator's position on the carriage. The carriage moves forward and backward past the

saw. On the forward movement, the log directed into the saw to cut the board from the side of the log.

11-3. As the log is being brought up in readiness to be placed on the carriage, you must consider the presence of extending knots or other obstructions that could prevent the log from lying firmly on the carriage or obstruct it as the carriage is brought forward.

11-4. You must also consider any bends in the log. The tendency for a new operator is to place the bow or "belly" of the log up or down. In fact, many old sawyers want the bow up and slightly out. It has been found by careful check as to the quality of lumber produced, that this procedure is definitely wrong. The correct position is with the bow of the log on a horizontal plane toward the operator's side to the carriage, and the log resting on all the head blocks over which it extends.

11-5. In this position, the log can easily be brought out on either end by use of a wedge or pried out with a cant hook so that the line of cut will be equal on each end.

11-6. Logs should be received on the carriage with the butt-ends (large ends) toward the saw, especially long logs, because the heavy butt on the overhanging end will

have a tendency to tip the carriage up. Also, the saw is now apt to run "out", that is, to follow the grain of the wood.

11-7. After the log is received on the carriage, it must be dogged. "Dogging" is the term given to the act of securing the log on the carriage by hooking the dogs into the log. This is very important, because improperly dogged logs or cant may result in accidents and usually result in damage to the saw, which in turn means loss of time and manpower.

11-8. The following hand tools are considered essential to the operation of a portable sawmill unit:

- a. Axe
- b. Shovel
- c. Oil can
- d. Cant hook
- e. Spirit level
- f. 8-inch half-round Ale
- g. Saw Ale
- h. 8-inch adjustable jaw wrench



Figure 50. Skidway.

- i. 10-inch adjustable jaw wrench
- j. Additional tools for the power unit

12. Caring for the Saw

12-1. Your job is not complete when you finish sawing the lumber. You must take care of the saw. It is impossible to place enough emphasis on taking care of the saw. It can truthfully be said that it is the most important part of any type of machine which converts logs into lumber, whether it be a stationary or a portable sawmill. If you do not take care of your saw, it can slash your production, ruin the accuracy of the dimensions of the lumber, and leave you in the depths of despair.

12-2. There is nothing on the sawmill that takes as much abuse as the saw. For instance, should a log come loose from the dogs while this tremendous strain is on the saw, it will very likely kink (bend) it, bringing a halt to operations and resulting in loss of time and manpower. All saws vary considerably and require different methods of handling. This is partly due to the hardness or mildness (softness) of the steel from which they are made.

12-3. **Teeth.** A new saw will always run well for a few hours. It may make a rather rough cut, but it will always run a few hours if the saw is tensioned for the proper speed and the natural lead is properly set. These facts assure you that, if the teeth can be kept properly sharpened (like new teeth), the saw will continue to run and cut in a true line. Therefore, when you find that it does not do this, the deviation usually indicates that the saw teeth have not been sharpened properly. It has been proven that if an improperly sharpened saw is too long it will lose the proper tension and may cause blisters to develop on the saw blade. If this happens, you will have to have a competent saw expert retension the saw by hammering it. Hammering a saw is an art and should under no circumstances be attempted by anyone with limited experience. When your saw ceases to cut properly, stop your operations and sharpen it.

12-4. **Blade.** Most of your sawing will be done with a chisel tooth. So let's find out how a chisel tooth saw works. Many saws used to cut wood lengthwise of the grain are swedge-set chisel tooth saws. Many saws used to cut crosswise of the grain are spring-set pointed tooth saws. A spring-set cutoff saw cuts the sides free and tears out the portion between the two edges that are cut free by the sharp points. Therefore, as soon as the point become dull and do not cut the edges free, further sawing is difficult, and the saw is said to be dull. Sharpening the points will correct this situation and you can resume your work. Inasmuch as the center is torn out, any slight increase in the kerf (cut or stroke) will

increase the amount to be torn out and will increase the power accordingly.

12-5. A rip chisel tooth saw cuts across the center and tears out the two corners. For this reason, the width of the cut or stroke does not materially affect the power required. The two edges have to be torn free, regardless of how narrow the cut or stroke is, and this is what consumes the power. Notice the chisel tooth shown in figure 51. The corners of the tooth do the tearing. Therefore, the things that lessen the tearing effect of the corners will affect the power consumption immediately and cause a corresponding increase in the power used through each tooth. This can cause much trouble. Therefore, the condition of the corners of the teeth is of great importance.

12-6. In addition, if one corner of the tooth becomes duller than the other, the one causing the greater resistance will have a tendency to force the saw the opposite way, which will cause the side of the saw to rub on the side of the log. If the saw rubs on the side of the log, it will do one of two things: (1) If the log is moving endways slowly, and if the saw is rotating as it rubs the slowly moving log, it will generate heat in the saw which will cause the metal to expand. This, in turn, will cause the saw to lose the stiffness required to run straight. The further this condition is allowed to develop, the more difficult it becomes to remedy. (2) On the other hand, if the log is passing the saw at a higher rate of speed, the saw will have a tendency to cool as it rubs against the log, because the inside of the

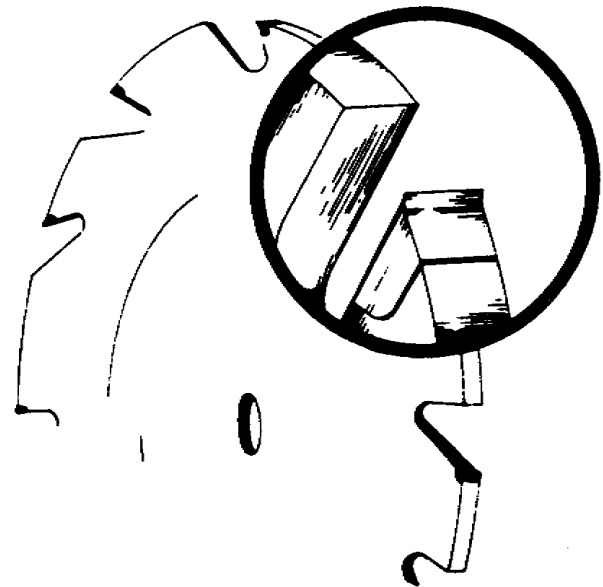

Figure 51. Chisel tooth.

log is cool. This will cause the metal to shrink and stiffen.

12-7. Another factor that will affect the operation of the saw is an improper angle on the front of the tooth. This will us the saw to run "in" or "out." Remember, the cutting edge of the saw should be straight across.

12-8. **Speed.** Usually, the speed of a portable sawmill is the greatest that can be maintained both in and out of the cut. A usual mistake of operators is to try to operate the saw at too great a speed. A regular uniform speed both in and out of the cut insures more lumber and more accurate lumber. The speed should be governed by the available horsepower, of course, and must be increased as the power to drive the saw is increased.

13. Basic Rules In Sawmill Operation

13-1. There are many basic rules that are important in sawmill operation. These rules apply to greasing the saw, handling the saw, and checking the carriage.

13-2. **Greasing.** While greasing the sawmill, do as follows:

- a. Apply heavy oil to the gears of the sawdust conveyor twice daily
- b. Use soft, light pressure gun grease.
- c. Use only pressure gun grease in grease gun.
- d. Lubricate the knee slides and gear rack slides and other moving parts frequently with light machine oil. Some sawmill operators make a

practice of lubricating the surface of the knees on which the log rests when they are taking on a large log because it helps in turning the log. Some operators use powdered graphite on the head block slides instead of oil.

- e. Remove all bearings on which the carriage slides and wash them out with solvent and repack them with pressure gun grease once a year.

13-3. **Saw.** In handling the saw, always observe the following rules:

- a. Don't ever saw with a "hot" saw.
- b. Never saw with dull teeth.
- c. Don't allow chips to rub the saw.
- d. Keep the saw clean of pitch. (NOTE: Pitch sticks only to a hot saw.)

13-4. **Carriage.** When checking the carriage, proceed as follows:

- a. Be sure that the carriage is level.
- b. Always check the carriage before you start sawing by running it up and down the track two or three time to determine whether the ropes are in order and the saw is in the clear.
- c. Always check the dogs when you are not sawing, especially on the "return" after the last board is cut from the log. Keep the dogs away from the saw.
- d. Always keep the saw guides adjusted properly.
- e. Always lock the carriage when you complete the day's work or whenever the machine is not in operation.
- f. Always put in the carriage bolt and lockpin and set the hand brake when you are going to move the mill.



**CORRESPONDENCE COURSE OF
U. S. ARMY ENGINEER SCHOOL**



SUBCOURSE 0533.....Carpentry III (Specialized Carpentry).
LESSON 1.....Cabinetwork.

SOLUTIONS

All references are to Memorandum 0533.

- | | |
|-------------------------|------------------------------|
| 1. <i>c</i> (par 1-7) | 11. <i>a</i> (par 3-29) |
| 2. <i>a</i> (par 2-11) | 12. <i>b</i> (par 1-14) |
| 3. <i>b</i> (par 2-13) | 13. <i>b</i> (par 2-15) |
| 4. <i>a</i> (par 2-17b) | 14. <i>c</i> (par 2-22) |
| 5. <i>b</i> (par 3-8) | 15. <i>d</i> (par 1-6) |
| 6. <i>d</i> (par 1-12) | 16. <i>d</i> (par 1-7) |
| 7. <i>a</i> (par 2-14) | 17. <i>c</i> (par 1-1) |
| 8. <i>d</i> (par 2-18) | 18. <i>a</i> (par 2-17) |
| 9. <i>a</i> (par 3-15) | 19. <i>b</i> (par 2-16) |
| 10. <i>c</i> (par 1-8) | 20. <i>c</i> (pars 3-7, 3-8) |

For further explanation, see Discussion.

DISCUSSION

Exercise:

1. **Cedar (c)** has a high resistance to decay. It is used as a liner for closets, cedar chests, etc., because of its moth repellent action.
2. **Lap (a)** joints are used by the carpenter or cabinetmaker to connect crossrails to the sides of cabinets.
3. **Dado (b)** joints are actually grooved joints with the groove running across the grain of the wood. They are used extensively in cabinet-drawer construction.
4. For rough knockdown or outside furniture, the tenon can be cut longer than the depth of the mortise, with a hole driven in the protruding part. This is called **keyed mortise and tenon (a)** joint.
5. **Stool (b)** construction is really four frames put together to form a rectangle or square. It is used for tables, chairs and stands.
6. When quartersawed, the medullary rays of **oak (d)** grain are broad and numerous, making pleasing patterns.
7. **Grooved (a)** joints have the groove, or plow as it is sometimes called, running with the grain of the wood. They are used extensively in panel construction.
8. To determine the proper thickness of a tenon, compare it with the member of which it will be a part. The tenon thickness should be about one-third the thickness (**d**) of the member.
9. Often tops are large enough to require two or more pieces to be glued together. The method of fastening them to the furniture is important because of the **swelling and shrinking (a)** of tops.
10. **Redwood (c)** holds paint exceptionally well, shrinks very little, and keeps its shape. It is used for garden furniture. These qualities make it best choice for the exposed locations of the shuttle bus stops.
11. Before you assemble the unit into final form, you must make a preassembly check by checking each piece for **dimensions, shape, and fit (a)**.
12. Hardwood is graded as follows: **first (b)**, second, select, No. 1 common, No. 2 common, and No. 3 common.
13. The **miter (b)** joint can be fastened with glue and metal fasteners. It is a diagonal joint and it is used extensively for frames and moldings.
14. The size of the dowel should be large enough to support the intended job without weakening it. The diameter should be approximately one-third to **1 (c)** the thickness of the stock on which it is being used.

15. **Fir (d)** is difficult to work with hand tool, but it glues well. It is used extensively in millwork and boatbuilding.
16. **Cedar (d)** has the qualities listed in the stem of the exercise. In addition, it works well, finishes smoothly, takes paint, and glues well.
17. In cabinetmaking, the desirable characteristics of wood are different from frame construction. For example, **beauty and finishing qualities (c)** would be determining factors rather than strength.
18. There are numerous variations of the mortise and tenon joint, providing ample choices for framing doors, panels, tables, chairs and cabinets. **Open, through, blind, and haunched (a)** are the four variations that should be recognized in the exercise.
19. The **splined (b)** miter is a method used to reinforce a plain miter joint. Figure 5c is one way of inserting a spline.
20. The framework adds strength because wood grain runs lengthwise in both length and width. Frame construction is highly desirable because it **overcomes shrinkage and swelling (c)** and provides ample strength for the panel. Stool construction is subject to shrinkage.



**CORRESPONDENCE COURSE OF
U. S. ARMY ENGINEER SCHOOL**



SUBCOURSE 0533.....Carpentry III (Specialized Carpentry).
LESSON 2.....Prefabricated Buildings.

SOLUTIONS

All references are to Memorandum 0533.

SOLUTIONS

All references are to Memorandum 0533.

- | | |
|--------------------------------|-------------------------|
| 1. <i>c</i> (par 4-18) | 11. <i>b</i> (par 5-14) |
| 2. <i>a</i> (par 4-23) | 12. <i>c</i> (par 5-2) |
| 3. <i>c</i> (par 5-19) | 13. <i>a</i> (par 5-1) |
| 4. <i>a</i> (par 6-4) | 14. <i>d</i> (par 5-2) |
| 5. <i>b</i> (par 5-26) | 15. <i>d</i> (par 4-3) |
| 6. <i>c</i> (par 4-12) | 16. <i>c</i> (par 4-8) |
| 7. <i>d</i> (par 5-10) | 17. <i>a</i> (par 4-17) |
| 8. <i>a</i> (par 5-31) | 18. <i>b</i> (par 5-16) |
| 9. <i>c</i> (pars 5-4, 5-2) | 19. <i>b</i> (par 5-26) |
| 10. <i>b</i> (pars 5-14, 5-16) | 20. <i>d</i> (par 5-31) |

For further explanation, see Discussion.

DISCUSSION

Exercise:

1. Tile and linoleum are not used on a wood floor if the floor is not reasonably **solid and covered with a smooth underlayment (c)**.
2. The **rafter spacing is the same as stud spacing (a)**, 4-foot on center.
3. The lap joint and the vinyl seal joint are the two common methods used to make weatherproof vertical joints in **exterior walls (c)**.
4. Two major modifications include the use of **floors that are of double thickness** and of **walls and roofs** that are **insulated (a)**. Heat is supplied by individual stoves or heaters.
5. The common metals used in construction are listed in the electromotive series in the following order: **1-aluminum (b)**, 2-zinc, 3-iron, 4-tin, 5-lead, 6-copper. When two of these are in contact the lowest number is corroded. The farther the separation in the list, the greater the corrosion.
6. Roof panels are built according to the climatic conditions that exist where the building is to be used. Insulated panels are used in both **hot and cold (c)** climates.
7. A bay is the **distance between columns along the side walls (d)**. There is no limit to the number of bays that can be placed end-to-end to form a building.
8. The glazing clip fits between the edge of the glass and the frame. One end fits into a hole in the frame and the other end hooks over the edge of the glass. The glass should be cut shorter than the sash by the **thickness of two clips (b)**.
9. The standard size of the quonset hut is 20 x 48 feet. The floor is made of 4 x 8 foot sheets of plywood.
$$\begin{array}{rcl} 20 \times 48 & = & 960' \text{ area of floor} \\ 4 \times 8' & = & 32' \text{ area of plywood sheet} \\ \frac{960'}{32'} & = & 30 \text{ sheets plywood (c)} \end{array}$$
10. The brace rods between the roof beams serve to hold the bay square, and the **sag rods (b)** are used to prevent the girts from sagging between the columns.
11. The sags rods are used to **prevent the girts from sagging (b)** between the columns. They are also used in the roof frame to hold the purlins line.
12. **Nails, screws, and bolts (c)** are used In the assembly of the quonset hut. These are easily removed when repair or disassembly of the unit is required.
13. Prefabricated metal buildings are constructed of many types of metal, but galvanized sheet metal and **aluminum (a)** are the most common metals that are used in this construction.

14 The standard size is **20 x 48 feet (d)**, but there are some quonsets that are two or three times longer. They can be assembled in 8-foot sections.

15. The joints between the panels are covered with the **T-shaped metal strip**, but when plywood is used for the floor, the edges and joints are protected by an **H-shaped metal strip (d)**.

16. The wall panels are fastened in place with double-headed scaffold nails or **bolts (c)**. The bolts fasten two pane together along the vertical edge.

17. The floor consists of **flooring, joists, and girders (a)**. Also, it may have a finish floor or the floor may be of concrete.

18. The brace rods are used to square the **end bays (b)** of the building. They run diagonally from the top of one column to the bottom of the adjoining column.

19. When aluminum panel are placed on a steel frame a separator must be used because direct contact of the two metals results in **corrosion (b)**.

20. The **glazing clips (d)** hold the glass in place while putty is applied. They fit between the edge of the glass and the frame. Use a screwdriver to install these clips.



**CORRESPONDENCE COURSE OF
U. S. ARMY ENGINEER SCHOOL**



SUBCOURSE 0533.....Carpentry III (Specialized Carpentry).
LESSON 1.....Heavy Timber Construction.

SOLUTIONS

All references are to Memorandum 0533.

- | | | | |
|--------------|------------|--------------|------------|
| 1. <i>d</i> | (par 8-13) | 11. <i>c</i> | (par 7-18) |
| 2. <i>c</i> | (par 8-18) | 12. <i>a</i> | (par 8-9) |
| 3. <i>b</i> | (par 8-34) | 13. <i>b</i> | (par 8-5) |
| 4. <i>a</i> | (par 8-19) | 14. <i>b</i> | (par 7-3) |
| 5. <i>a</i> | (par 8-24) | 15. <i>d</i> | (par 8-4) |
| 6. <i>b</i> | (par 8-16) | 16. <i>d</i> | (par 8-9) |
| 7. <i>a</i> | (par 8-16) | 17. <i>a</i> | (par 8-14) |
| 8. <i>a</i> | (par 8-13) | 18. <i>b</i> | (par 8-19) |
| 9. <i>a</i> | (par 8-13) | 19. <i>a</i> | (par 8-13) |
| 10. <i>c</i> | (par 7-7) | 20. <i>d</i> | (par 8-15) |

For further explanation, see Discussion.

DISCUSSION

Exercise:

1. These piles should be spaced **6 to 10 feet apart center-to-center in one direction, and 5 feet apart center-to-center in the other direction (d)**. Bearing piles support the wharf or pier framework or decking. The length varies according to the depth of the water.
2. The decking should be at least **3 (c)** inches thick and joined directly over the joists. The joints should be staggered for greater strength.
3. If the decking is 3 inches thick, 60d nails or **6-inch (b)** spikes should be used. If the decking is 4 inches, a 7- or 8-inch spike should be used.
4. **Timber carriers (a)** are considered two-man tools. They are primarily used to pick up and carry timber.
5. Decay is caused by the action of low parasitic forms of plant life known as **fungi (a)**. This decay facilitates the action of termites and marine borers.
6. Caps are large timbers which are placed on top of the bearing piles. **Pier girders (b)** rest on the caps and are secured to the caps with drift pins.
7. In wharf construction, the girders may rest **directly on the bearing pies (a)**. They would be secured with drift pins.
8. The **bearing (a)** piles support the pier framework and decking. They are spaced 6 to 10 feet apart in one direction and 5 feet apart in the other direction, all center-to-center.
9. The piles are 60 to 80 feet in length; the length varies according to the **depth of the water and condition of the bottom (a)**.
10. Joists are usually spaced from 16-24 inches on center. If planned spacings may not support the intended load you should **use heavier joists rather than reduce the spacings (c)**.
11. Soil and wood treatment, termite shields, and preservative treatment are some of the methods used to discourage termite infiltration, but if termite colonies still accumulate, consult your **entomologist (c)**.
12. Usually **timber (a)** is the most widely used because it is more economical, lighter, and easier to work. The serviceable life of timber, however, is shorter because it is subject to decay by fungi action.
13. **Piers (b)** are constructed perpendicular or approximately perpendicular to the shore line. Vessels can tie up on either side.
14. Loading dock foundations in most cases are spaced from **6 to 10 feet (b)** apart. They must be spaced according to the weight they may carry.

15. **Wharves and quays (d)** are constructed parallel or approximately parallel to the shore line to provide berthing or docking for seagoing vessels.
16. **Timber (d)** is more economical and easier to work. The serviceable life of timber is shorter, but its life can be extended by protecting the timber with a preservative.
17. To protect the pilings from direct contact with a moving ship, **fender piles (a)** are placed about 2 1/4 feet out from the center line of the outside row of the bearing piles.
18. Logger's tools are used to move and place heavy timbers. **Pike poles (b)** are used to hold or to steady timbers while the timbers are being placed.
19. Bearing piles support the wharf or pier **framework and decking (a)**. They should be straight and measure at least 6 inches across the top and 18 inches across the bottom. The length is from 60 to 80 feet.
20. The mooring piles are spaced approximately **30 (d)** feet apart, and placed in line with the outside row of bearing piles.

CARPENTRY III (Specialized Carpentry)

CREDIT HOURS.....11.

TEXT ASSIGNMENT.....Review previous lessons.

EXERCISES

1. You are selecting wood to build a cabinet that will be painted. You have only hand tools. What kind of wood do you select?
 - A. Walnut
 - B. Oak
 - C. White pine
 - D. Mahogany

2. Where would you use lap joints when making a cabinet?
 - A. in moldings
 - B. in panels of the door
 - C. in framework grooved for panels
 - D. to connect crossrails to sides of cabinet

3. How would you use dowel joints?
 - A. on moldings.
 - B. for fastening cabinet drawers
 - C. to reinforce butted boards
 - D. to strengthen frames.

4. You require two pieces of material that you will glue together for a cabinet top. What do you specify?
 - A. each piece same size
 - B. pieces have equal weights
 - C. must have opposite grains
 - D. must have similar grains

5. In what direction would you sand a piece of wood used for a front on a cabinet drawer?
 - A. diagonally to the grain
 - B. with the grain
 - C. across the grain and perpendicular to it
 - D. a scrubbing motion in all directions

6. You have received detailed drawings and a blueprint for constructing desk drawers. When you start cutting the wood, how would you mark the pieces?
- A. "sides", "fronts", "backs"
 - B. "sides" (identified "left", "right"), fronts, backs
 - C. 1, 2, 3, 4, 5
 - D. sides, fronts, tops
7. You have received parts for a wooden article. They are supposed to have been milled to size, shaped, and sanded. You must now make a preassembly check of each part. What do you check first?
- A. dimensions
 - B. shape
 - C. fit
 - D. weight
8. What wood do you recommend for making fine furniture?
- A. cedar
 - B. redwood
 - C. mahogany
 - D. plywood
9. What is the spacing of the rafters in a framed prefab building?
- A. 4-foot
 - B. 4-foot on center
 - C. 3-foot on center
 - D. 3-foot on edge
10. How far apart in feet do you space the floor girders that run the length of a quonset hut?
- A. 4'10" on center
 - B. 5' on center
 - C. 5'1" on edge
 - D. 5'1" on center
11. Why would you place screws through each of the four holds in the bottom of the stud in a quonset hut?
- A. to serve as a fastening point for siding
 - B. to remove a stud
 - C. to splice two lengths of channel plate
 - D. to fasten arch ribs to the channel plate

12. You are erecting a prefab building in the tropics. What kind of floor do you specify?
- A. earth
 - B. concrete
 - C. wood
 - D. metal
13. Why would you use girts in erecting prefab buildings?
- A. provide fastening surface for wall exterior coverings
 - B. to hold the corners square
 - C. to keep girders in place
 - D. to strengthen floor joists
14. Which of the following states the parts of the floor frame in a quonset hut?
- A. metal studs, purlins, headers
 - B. sag rods, struts, beams
 - C. girders of joist sills, and joists
 - D. brace rods, frame, splice plates
15. Which of the following metal contacts would produce the most corrosion in the presence of an electrolyte?
- A. aluminum with lead
 - B. aluminum with zinc
 - C. copper and tin
 - D. zinc with iron
16. How many bays can be placed end-to-end to form a building?
- A. 10
 - B. 20
 - C. 35
 - D. any number
17. What is the purpose of retaining walls?
- A. protect shore from soil erosion
 - B. provide berths and slips
 - C. facilitate overhaul of seagoing vessels
 - D. reduce cargo-unloading time
18. Wharves and piers can be constructed from timber, concrete, or steel. Why would you choose timber?
- A. more economical
 - B. heavy
 - C. immune to fungi action
 - D. rarely deteriorates

19. Which of these factors would you use as your primary guide in planning a loading dock?
- A. nearness of railroad
 - B. dimensions of cargo
 - C. contents of cargo
 - D. size of cargo handled and weight on platform
20. How many inches apart on center would you space the joists for a loading dock?
- A. 13 to 21
 - B. 14 to 22
 - C. 15 to 23
 - D. 16 to 24
21. Which is the most successful way to stop fungi action?
- A. keep area moist
 - B. increase surrounding temperature
 - C. poison the food supply
 - D. increase air circulation
22. How far apart in feet are loading-dock foundations usually placed?
- A. 4 to 9
 - B. 5 to 9
 - C. 6 to 10
 - D. 7 to 15
23. Which of these statements do you accept?
- A. when joists are being placed, the greatest bearing surface is used
 - B. joists are spaced 16 to 24 inches on center, but if this is too wide for load, spacing should be narrowed
 - C. girders are needed in dock construction if joists safely span the distance from sill to sill
 - D. decking on loading docks should be at least 5 inches thick and laid parallel to the joists.
24. You have decided to use creosote on some timbers as a preservative. At what temperature would you apply the creosote?
- A. 180° to 250° F
 - B. 175° to 200° F
 - C. 160° to 180° F
 - D. 150° to 180° F

25. In constructing prefabricated buildings in temperate, tropic, and arctic regions which of these items would you use as a guide?
- A. in a temperate climate, floors must be wood
 - B. in tropic regions, floors must be wood resting on leveled dirt foundation
 - C. in arctic regions window openings are very large to take advantage of solar heat
 - D. in arctic regions, floors must be doubled and walls and roofs insulated